



PacketWave™
Fixed Broadband Wireless System

PacketWave 600 Series

Installation, Configuration, and Operation Manual
for Software Version 1.0

©Copyright 2002 by Aperto Networks

All rights reserved.

Specifications subject to change.

Aperto, PacketWave, and WaveCenter are trademarks of Aperto Networks.
All other trademarks used herein are the property of their respective owners.

Aperto Networks
1637 South Main Street
Milpitas, CA 95035 USA

Phone: 408.719.9977
Fax: 408.719.9970

www.apertonet.com

REGULATORY INFORMATION

FCC PART 15

This device complies with Part 15 of the FCC Rules. Operation is subject to the following two conditions:

- this device may not cause harmful electromagnetic interference, and
- this device must accept any interference received including interference that may cause undesired operations.

Note: Changes or modifications not approved by Aperto may void the user's authority to operate this equipment.

FCC NOTICE: Radio and Television Interference

The PacketWave™ 600 Series Base Station Equipment has been tested and found to comply with the limits for a Class A digital device, pursuant to Part 15 of the FCC Rules. These limits are designed to provide reasonable protection against harmful interference in a residential installation. This equipment generates, uses, and can radiate radio frequency energy and, if not installed and used according to the instructions, may cause harmful interference to radio communications. However, there is no guarantee that interference will not occur in a particular installation. If this equipment does cause harmful interference to radio or television reception, which is found by turning the equipment off and on, the user is encouraged to try to correct the interference by one or more of the following measures:

- Reorient or relocate the receiving antenna.
- Increase the separation between the equipment or device.
- Connect the equipment to an outlet other than the receiver's.
- Consult a dealer or an experienced radio/TV technician for assistance.

RF Exposure Notice

The installer shall mount all transmit antennas so as to comply with the limits for human exposure to radio frequency (RF) fields per paragraph 1.1307 of FCC regulations. The FCC requirements incorporate limits for Maximum Permissible Exposure (MPE) in terms of electric field strength, magnetic field strength, and power density.

CAUTION: 5.8 GHz UNII — To comply with FCC RF exposure requirements, antennas used for this device must be installed to provide a separation distance of at least 2 m from all persons to satisfy RF exposure compliance.

Canadian Standards Compliance

This Class A digital apparatus complies with Canadian ICES-003

Cet appareil numérique de la classe A est conforme
à la norme NMB-003 du Canada



Scope of This Manual

This manual documents the installation, configuration, and operation of the PacketWave 600 Series of Base Station and Subscriber Unit Equipment with software version 1.0.

This manual provides the following information:

- A conceptual overview of the PacketWave System.
- Descriptions of the PacketWave hardware components, including base station and subscriber equipment.
- Descriptions of the PacketWave software components, including configuration programs and management interfaces.
- Complete installation instructions
- System configuration, management, and diagnostic procedures.

Conventions Used in This Manual

The term “Base Station Equipment” refers to the combination of the Base Station Indoor Unit, the radio, and the antenna. The term “Base Station Unit” refers to the Base Station Indoor Unit.

PacketWave manuals represent special kinds of text as follows:

- File names and URLs are represented in italics, with variables described inside angle brackets. For example, if the URL *http://<IP address>/* is referenced, you will replace the variable *<IP address>* with the appropriate real IP address.
- Management interface text is represented by a bold font: for example, the **Generate Config File** button.

- Labels on equipment are represented in a bold font: for example, the **Control** connector.



WARNING: This format is used to indicate the possibility of personal injury or serious damage to equipment.



CAUTION: This format is used to indicate the possibility of system or equipment operation problems.



Items of special importance will be formatted and marked by a pointing-hand icon, as this paragraph is.

Intended Audience for this Manual

This manual is intended for system designers and planners, base station installers, system operators, and others requiring or desiring information about the PacketWave System. It provides information specific to the PacketWave system, but cannot and should not be considered a tutorial on relevant technologies and practices.

It is expected that system designers and planners are knowledgeable about radio communications, cellular communication systems, and IP networks. Tutorials on these subjects are beyond the scope of this manual, and are readily available in published and online materials.

Installation of radio equipment involves numerous factors, such as lightning and weather protection, requiring considerable expertise. It is assumed that equipment installers are professionals with knowledge of the principles and standard practices and procedures of cell site installation, all relevant safety requirements, and applicable local building codes.

General Cautions and Warnings

Observe the following when installing or operating any PacketWave System components.

Carefully follow all local building and electrical codes, especially the latest revision of the National Electrical Code (NEC) and standard safety procedures for installing and working with this type of equipment. Improper procedures or installation can result in damage to the equipment or the building, and injury or death. If you are not sure

about whether the installation follows these codes, contact a licensed building inspector or electrician in the area for assistance.

Always use quality components—including cables, connectors, mounts, etc.—specifically rated for your particular environmental conditions and system performance requirements.

Always use appropriate tools, and follow the instructions of the tool manufacturers.

All outdoor installation, including equipment mounting and cabling, should be performed by trained microwave radio technicians familiar with usual and customary practices and procedures.

Take extreme care to avoid contacting any overhead power lines, lights, and power circuits while you are installing outdoor equipment. Contact with any of these objects could cause injury or death. Do not install outdoor equipment near power lines.

Observe all customary and mandatory safety requirements when installing and operating PacketWave equipment.

Because Aperto cannot be responsible for improper installation or use of its equipment, failure to follow these and other published cautions and warnings may void your equipment warranty.



REGULATORY INFORMATION	iii
<hr/>	
Preface	
Scope of This Manual	xi
Conventions Used in This Manual	xii
Intended Audience for this Manual	xii
General Cautions and Warnings	xiii
<hr/>	
Chapter 1. Overview	
Hardware	1-1
Outdoor Unit	1-2
Indoor Unit	1-2
Front-Panel LED	1-3
Hardware Installation	1-4
Mounting the Outdoor Unit	1-4
Grounding the Outdoor Unit	1-5
Indoor Unit Installation	1-7
Cable Installation	1-8
Radio Signal Connection	1-9
Radio Control Connection	1-9
Ethernet 10/100 Base-T Connection	1-11
Software Overview	1-12
Configuration	1-12
SNMP	1-12
Event Reporting	1-12
<hr/>	
Chapter 2. Installation and Configuration	
Introduction	2-1
What You will Need	2-1
Getting Started	2-1
Performing the Installation	2-2

Installing the PW620	2-2
Start the Application	2-3
Choose the Installation Mode	2-4
Fill out the Configuration Parameters	2-5
Accept the Default Configuration	2-7
Allow AIM to Configure the PW	2-7
Installing the PW610	2-9
Start the Application	2-9
Choose the Installation Mode	2-10
Fill out the Configuration Parameters	2-10
Accept the Default Configuration	2-12
Allow AIM to Configure the PW	2-12
Align the Antenna	2-13
Allow AIM to Perform the Installation and Throughput Test	2-14
View the Results and Re-align Antenna if Necessary	2-16
Running a Non-destructive Test	2-17
Antenna Polarity	2-18
What are the Options	2-18
When to use Antenna Diversity	2-18
Installation with Antenna Diversity	2-19
Problem with Signal Indicator in Installation Manger	2-21

Chapter 3. Base Station Unit Web GUI

Accessing the BSU's Web Interface	3-2
Operation of the Web GUI	3-3
Main Menu and Submenu	3-3
Submitting and Uploading Changes	3-3
Cancel and Refresh Buttons	3-3
Hyperlinks	3-3
The Web GUI Home Page	3-4
BSU/SU Connectivity	3-4
Overview of BSU Web GUI Functions	3-5
Configuration Pages	3-6
System Configuration	3-6
Administration	3-7
Password	3-7
SNMP	3-8
Local Time	3-10
IP Filters	3-11
Wireless Interfaces	3-12
HTML Upgrade	3-14
Utilities	3-14
Device Control	3-14
Status Pages	3-16
Performance Pages	3-18
Fault Reporting Pages	3-21
Event Log	3-21

E-mail Configuration	3-22
----------------------------	------

Chapter 4. Subscriber Unit Web GUI

ISP and Subscriber Logon Levels	4-1
Accessing the Web Interface	4-2
Features of the Web Interface	4-4
Home Page: Connectivity View	4-4
Main Menu and Submenu	4-5
Submitting and Uploading Changes	4-5
Cancel and Refresh Buttons	4-5
Hyperlinks	4-5
Overview of SU Web GUI Functions	4-6
Configuration Pages	4-7
System Configuration	4-7
Administration Configuration	4-7
Password Configuration	4-8
SNMP Configuration	4-9
Default Best Effort Configuration	4-9
Radio Configuration	4-11
IP Filter Configuration	4-11
Device Control Utility	4-13
Fault Reporting Pages	4-13
Event Log Page	4-14
E-mail Configuration Page	4-15
Status Pages	4-15
Performance Pages	4-15

Chapter 5. Antennas

Appendix A. Specifications

Appendix B. Event Reporting

Appendix C. Command Line Interface (CLI)

Appendix D. RF Signal Quality



Overview

This chapter outlines the basics of the PacketWave 600 Series hardware, software, and installation.

Hardware

There are two models in the PacketWave 600 Series. For each link, the PacketWave 620 is the master (also refer to as the base station) and the PacketWave 610 is the slave (also refer to as the subscriber unit). Although they have different hardware and software internally, they look the same from outside except for the model number on the back panel.

Each PacketWave 600 Series equipment consists of an Outdoor Unit (radio/antenna), and an Indoor Unit (bridge), as shown in *Figure 1-1*.



Figure 1-1 **PacketWave 600 Series Equipment**

Outdoor Unit

The outdoor portion of the equipment consists of a single unit containing the radio and antenna. Different models support various frequency bands:

- 2.5 GHz MMDS
- 3.5 GHz FWA
- 5.8 GHz U-NII



Figure 1-2 **Outdoor Units**

As shown in *Figure 1-2*, sizes of the antennas vary with the frequency band, from approximately 9 inches square to approximately 13 inches square. Outdoor units mount easily on a office roof or on a tower. The antennas are directional, with a beam width of 17° to 20° horizontally and vertically depending on frequency.

Depending on distance, a line-of-sight path may not be required for establishment of a wireless link between the subscriber and the base station. PacketWave's OptimaLink™ technology minimizes the effects of obstructions in the path between the subscriber's antenna and the base station antenna.

Indoor Unit

The Indoor Unit is a bridge with following interfaces.

- **10/100Base-T:** auto-negotiation with 10/100Base-T Ethernet LAN.
- **Radio IF:** provides radio signal and power for the Outdoor Unit.
- **Radio Control:** provides control signal for the Outdoor Unit.

The Indoor Unit is a free-standing unit which can be placed virtually anywhere indoor with controlled environment, subject to the following basic requirements:

- The Indoor Unit must be upright, with adequate air flow around it.
- The unit must have access to AC power.
- The cable runs to the Outdoor Unit can be up to 100 m (330 ft) with proper cable (See cable requirement in *Table 1-B*).

The Indoor Unit comes with an external power supply and power cord that plugs into a standard AC wall plug (120 or 220 volts).

Front-Panel LEDs

Table 1-A contains the operational information for the Indoor Unit's front panel LED.

Table 1-A **Front-Panel LEDs**

	LED	Indications
	LAN TX	<i>Blinks</i> on Ethernet transmit activity.
	RX	<i>Blinks</i> on Ethernet receive activity.
	LINK	<i>On</i> when Ethernet link is up; <i>Off</i> when it is down.
	WIRELESS TX	<i>Blinks</i> on wireless transmit activity.
	RX	<i>Blinks</i> on wireless receive activity.
	STATUS	<i>Off</i> : Indoor Unit is not operational. <i>Slow blink</i> : received wireless initialization signals. <i>Fast Blink</i> : in ranging process. <i>On</i> : configuration file received; Indoor Unit operational.
	POWER	<i>Green</i> when Indoor Unit is receiving power from AC source and has not failed boot diagnostics. <i>Amber</i> if boot diagnostic failure. <i>Off</i> if unit not receiving power.

Hardware Installation

You will need the following tools and supplies for installation.

- Drill (for cable entry through walls, etc.)
- Phillips screwdriver
- Wrench (7/16 inch)
- Cable Tools
- Cable tester (10Base-T and EIA/TIA 568B)
- Cable ties, staples, or clamps for dressing cables
- Silicone sealant
- PC laptop for antenna pointing using Advanced Installation Manager

You will also need the following cables and connectors:

- Coaxial cable (quad shield), long enough to run between Indoor and Outdoor Units, and two male F connectors (see *Table 1-B*)
- Shielded Cat 5 cable (outdoor rated), long enough to run between Indoor and Outdoor Units, and two RJ45 male connectors (see *Table 1-B*).
- Spare radio signal and control cables with connectors (each 30 feet or longer), for connecting Indoor and Outdoor Units during antenna pointing
- Ethernet cable with RJ45 male connectors (straight-through for connection to hub, or crossover for connection to computer)

Mounting the Outdoor Unit (Radio/Antenna)

Outdoor Units are designed for mounting on a pole or antenna mast with a diameter of 1.5 inch (3.8 cm) or 2 inches (5.1 cm) using a rear-mounted bracket as shown in *Figure 1-3*.



WARNING: This manual assumes that outdoor installation procedures will be performed by qualified professionals following all safety and other requirements and acting in accordance with standard practices and procedures. Failure to meet safety requirements and/or non-standard practices and procedures could result in personal injury and/or damage to equipment.

To mount an Outdoor Unit on a pole:

1. Loosen the pole clamp bolt and open the pole clamp.
2. Close the pole clamp around the pole.
3. Adjust the azimuth and elevation orientation of the radio/antenna.

4. Tighten the pole clamp bolt until the Outdoor Unit is secured in position.

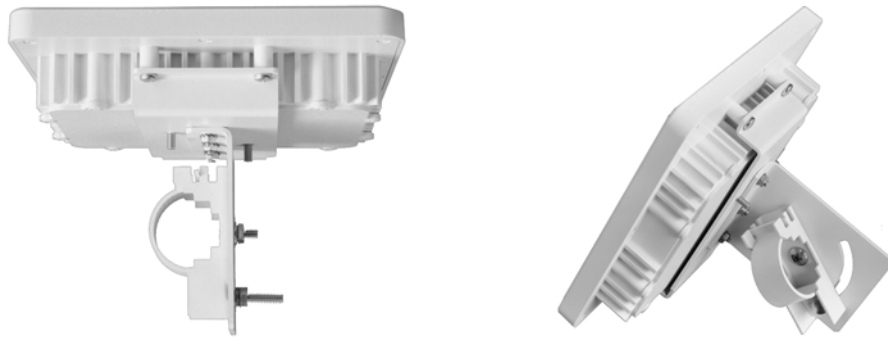

Figure 1-3 **Outdoor Unit Mounting Bracket**

Grounding the Outdoor Unit

Grounding of the outdoor radio/antenna is an essential part of the installation process. A proper grounding circuit is illustrated in *Figure 1-4*.



WARNING: Each PacketWave 600 Series Unit is required to have lightning protection. Instructions and specific example of lightning protection equipment is contained in the document titled *Surge Protection for PacketWave Products*. This document is included in the CD that shipped with the equipment. If missing, please contact Customer Service. Failure to follow the instructions will void your equipment warranty.

To properly ground the Outdoor Unit:

1. Locate the installed lug on the back of the Outdoor Unit. (See *Figure 1-5*.)
2. Provide a proper grounding conductor (NEC Section 810-21) long enough to reach from the Outdoor Unit to the earth ground.
3. Attach one end of the conductor to the lug.

4. Connect the other end of the grounding conductor to an appropriate earth ground using a grounding clamp.



If you install a grounding electrode separate from the power service grounding electrode system, connect the separate electrode to the grounding system in accordance with the National Electrical Code (NEC) and local electrical codes.

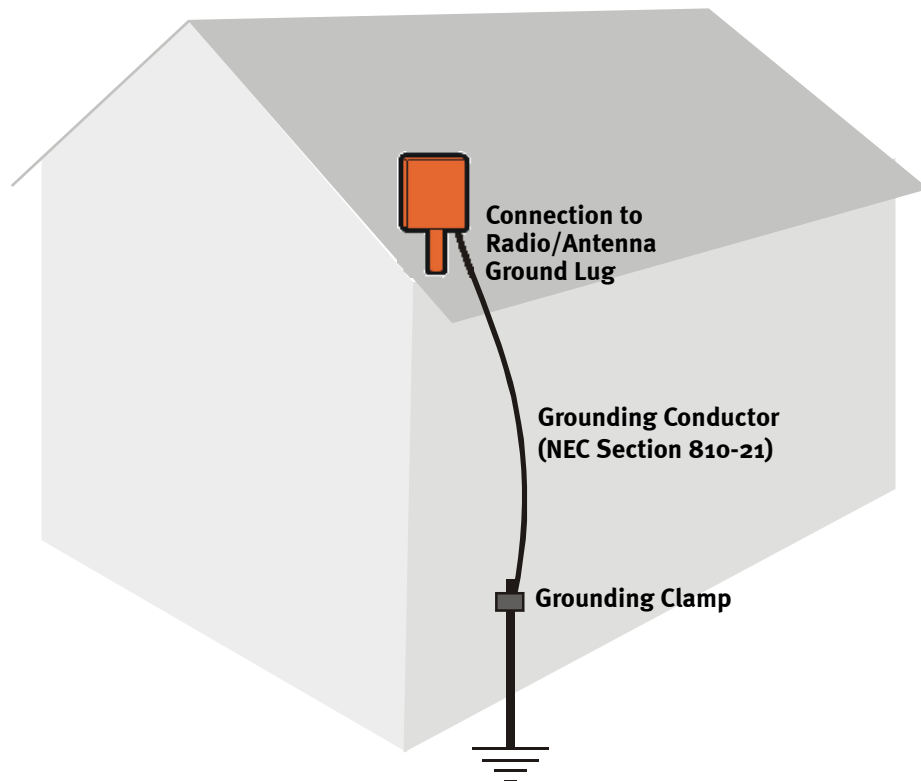
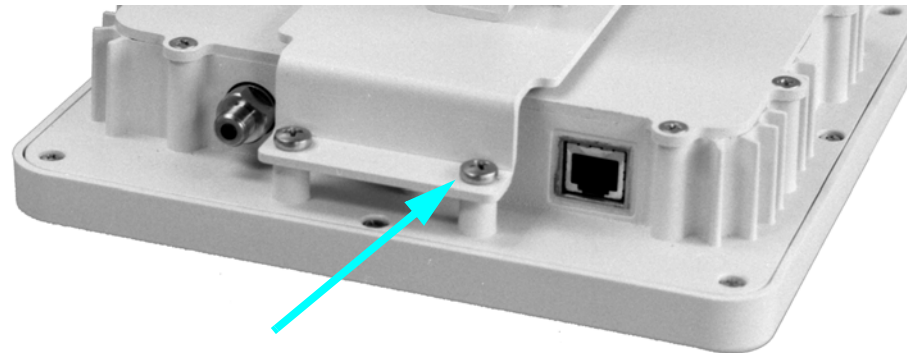

Figure 1-4 **Grounding the Outdoor Unit (Radio/Antenna)**



Lug installed here for ground connection

Figure 1-5 *Location of Grounding Lug on Outdoor Unit (Radio/Antenna)*

Indoor Unit Installation

Installation of the Indoor Unit involves placing the unit in the desired location, connecting radio/antenna and local Ethernet cables to the rear panel, and applying power.



WARNING: **For proper cooling, the Indoor Unit must be installed in the upright position, with adequate air flow around and through it.**

To apply power to the Indoor Unit:

1. Plug the power cord into the **Power** connector on the Indoor Unit,.
2. Plug the power cord/transformer into a surge-protected AC outlet.

The Indoor Unit does not have an on/off switch; to turn the unit off, disconnect power at the power outlet.

Cable Installation

There is one cable for Ethernet connection and two cables that connect the Indoor Unit to the Outdoor Unit:

- A RG-6 quad shield coaxial cable for the subscriber signal (which also provides DC power to the Outdoor Unit).
- A shielded outdoor-rated Cat 5 cable for controlling the Outdoor Unit.



CAUTION: Always power off the Indoor Unit before connecting or disconnecting the cable from the Outdoor Unit.

Table 1-B provides the types of cable required for the PacketWave 600 Series. For the Outdoor Unit to be located more than 50m (165 ft) from the Indoor Unit, the Radio Signal cable has to be RG-6 quad shielded with copper center and the Radio Control cable has to be CAT 5E.

Table 1-B PacketWave 600 Series Cable Requirement

Connection — Qty	Cable Type	Max. Length	Connectors
Ethernet (1)	Cat 5	100 m (330 ft)	RJ45 male
Radio Signal (1)	RG-6 quad shield coaxial	50 m (165 ft)	Male F type
	RG-6 with copper center conductor, quad shield	100 m (330 ft)	Male F type
Radio Control (1)	Shielded Cat 5, Outdoor-rated	50 m (165 ft)	RJ45 male
	Shielded Cat 5E, Outdoor-rated	100 m (330 ft)	RJ45 male



CAUTION: Specific models of cable are listed in a document titled *Cables for PacketWave Product*. This document is included in the CD that shipped with the equipment.

Radio Signal Connection

To install the radio signal cable, perform the following steps

1. Obtain an appropriate length of cable, and run it from the Indoor Unit to the Outdoor Unit. Include a service/drip loop as appropriate.
2. Install a male F connector at each end of the cable.
3. Attach the cable to the female F connector on the Outdoor Unit, as shown in *Figure 1-6*. Tighten the connector until the cable is firmly secured, but do not over-tighten.
4. Attach the cable to the **Radio IF** connector on the Indoor Unit as illustrated in *Figure 1-7*.



*The **Radio Control** connector of the Indoor Unit has the same physical appearance as the **10/100Base-T** connector. Make sure you connect to the right one.*

5. Dress the cable as appropriate.

Radio Control Connection

To install the radio control cable, perform the following steps

1. Obtain an appropriate length of cable, and run it from the Indoor Unit to the Outdoor Unit. Include a service/drip loop as appropriate.
2. Place the supplied rubber boot over the radio/antenna end of the cable.
3. Install an RJ45 male connector on each end of the cable.
4. Plug the cable into the RJ45 socket on the Outdoor Unit as shown in *Figure 1-6*.
5. Slide the rubber boot over the R-J45 connection so that it is tight against the radio/antenna housing; then secure the boot in place with a cable tie.
6. Attach the cable to the **Radio Control** connector on the Indoor Unit as shown in *Figure 1-7*.
7. Dress the cable as appropriate.

Seal the entry of both cables to the building as appropriate.

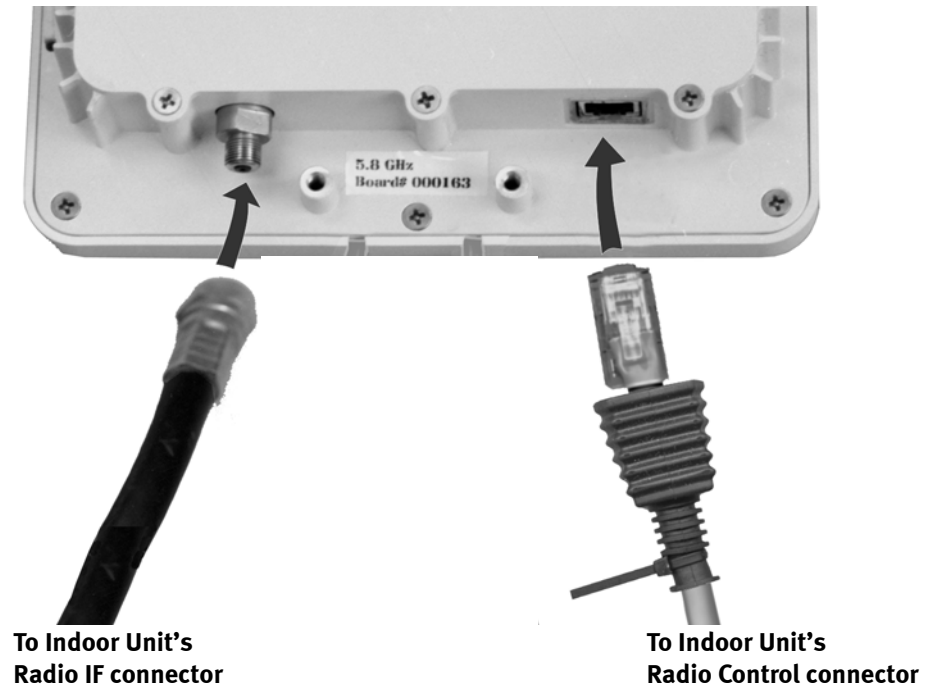

Figure 1-6 *Connections to the Outdoor Unit*

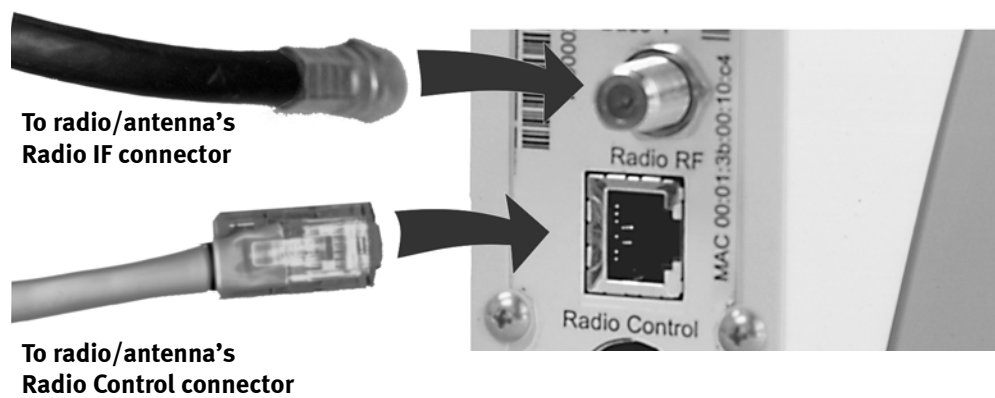

Figure 1-7 *Connections to the Indoor Unit*

Ethernet 10/100 Base-T Connection

To connect the Indoor Unit to Ethernet device.

1. Provide an appropriate Cat 5 Ethernet cable with an RJ45 male connector at each end. Use a straight-through cable for connection to a hub or router. Use a crossover cable for connection directly to a computer.
2. Plug one end of the Ethernet cable into the RJ45 socket labeled **10/100Base-T** on the Indoor Unit, as illustrated in *Figure 1-8*.



*The **Radio Control** connector of the Indoor Unit has the same physical appearance as the **10/100Base-T** connector. Make sure you connect to the right one.*

3. Plug the other end of the Ethernet cable into the socket on the local Ethernet device.

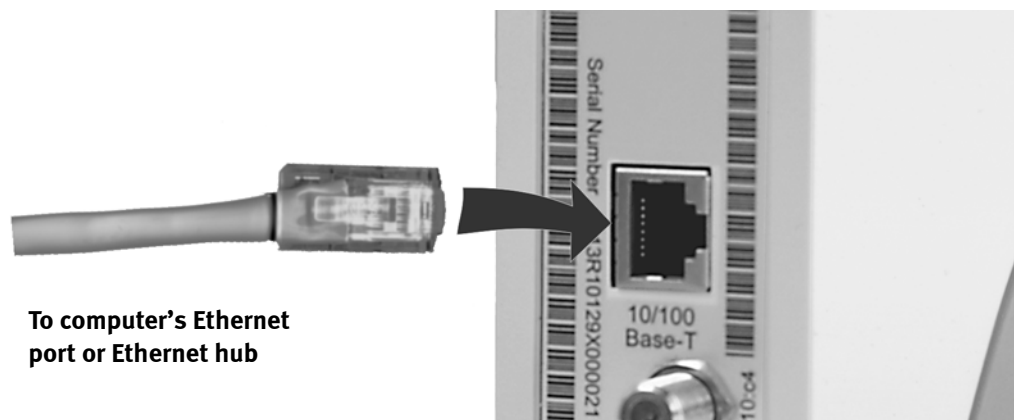

Figure 1-8 Ethernet 10/100 Base-T Connection

Software Overview

Configuration

The PacketWave 600 Series equipment is configured using the Advanced Configuration Manager (AIM) described in Chapter 2. The resulting configuration file is saved into the unit's permanent memory.

Some configuration of equipment can be performed via the Web GUI or SNMP. If desired, these configuration changes can be made permanent by saving them into the unit's permanent memory. If configuration changes are made via the Web GUI or SNMP is not saved, they will be lost when the Indoor Unit is reset or re-powered. See Chapter 3 and 4 for more details on Web GUI.

SNMP

Each Indoor Unit includes an SNMP agent supporting the following MIBs:

- SNMP MIB (RFC 1157)
- MIB II (RFC 1213)
- Aperto private MIB

The complete MIBs are provided on the PacketWave CD-ROM. SNMP can be used to read configuration, status, and performance data from PacketWave 600 Series Units. In addition, SNMP can be used to change some configuration parameters (those which can be changed via the Web GUI), and to upload the configuration changes to the unit's permanent memory.

The SNMP agents support trap reporting. Trap-reporting parameters can be specified via the Web GUI as well as via SNMP.

Event Reporting

PacketWave 600 Series Units offer several means of reporting equipment events:

- **E-mail messages** — The Subscriber Unit can be configured (via the Web GUI, or SNMP) to report events via e-mail to specified addresses.
- **SNMP traps** — The Indoor Unit's SNMP agent supports trap reporting. Trap-reporting parameters can be specified via the Web GUI, or SNMP.
- **Event log** — A historical event log can be presented on request via the Web GUI.

For information about specific subscriber equipment events which can be reported, see *Appendix B*.



Installation and Configuration

Installation and configuration of the PacketWave 600 series are provided in this chapter.

Introduction

The PacketWave series 600, point-to-point system consists of two indoor and two outdoor units. The indoor units have master and slave capabilities. The slave unit is the PacketWave 610 and the master unit is the PacketWave 620.

The installation software that help you configure, install, and aim your antenna is the Advanced Installation Manager (AIM).

What you will need

The PacketWave series 600 kit is supplied with everything you need. The only additional equipment you'll need is an Ethernet cross-over cable and a PC (or PC compatible) with an Ethernet connection and enough memory and disk space to run the Java application. We suggest a laptop PC with 256 Mbyte memory, 10 GB disk drive, Pentium processor, and ethernet LAN connection. Systems as small as 128 Mbyte memory and a 386 processor have been used. They do work, but not very satisfactorily.

Getting started

Preparing the PC

The PacketWave 600 comes with Java software from SUN Microsystems.

- Install the file j2re-1_3_0_02-win.exe from the \Software\Application\Support directory of your CD-ROM.
- Next install the Setup.exe from the \Software\Application\AdvancedIM\win32 directory.
- Connect your Indoor Unit (IDU) to your Outdoor unit (ODU) using the appropriate RG6 and CAT-5 cabling.
- Connect your PC to the PacketWave 620 (PW620) IDU using an Ethernet cross-over cable.

Performing the Installation

To install the PacketWave 600 series point-to-point link you should first install the PacketWave 620 (PW620) and then install the PacketWave 610 (PW610). Detailed instructions follow.

Installing the PacketWave 620 - PW620

To install the PW620 you need to perform the following steps

- Connect the PC and the PW620
- ***Start the Application***
- ***Choose the Installation Mode***
- ***Fill Out the Configuration Parameters or Accept the Default Configuration Parameters***
- Allow ***AIM to Configure the PacketWave***

Connect the PC and the PW620

Connect your PC to the PW620 using an Ethernet cross-over cable. It is best to only have one Ethernet connection on your PC. The AIM application has no way to distinguish which Ethernet interface to use. If you have multiple Ethernet interfaces, disable all of the extra ones.

AIM is going to calculate an address in the current subnet of the PC to give to the PacketWave devices in order for it to make an IP connection. It therefore requires that the PC have a fixed IP address; not one assigned by a DHCP server. The figure below, *Figure 2-1*, gives

an example of setting a fixed IP address on Windows 2000. Be sure to choose the “Use the following IP address” selection.

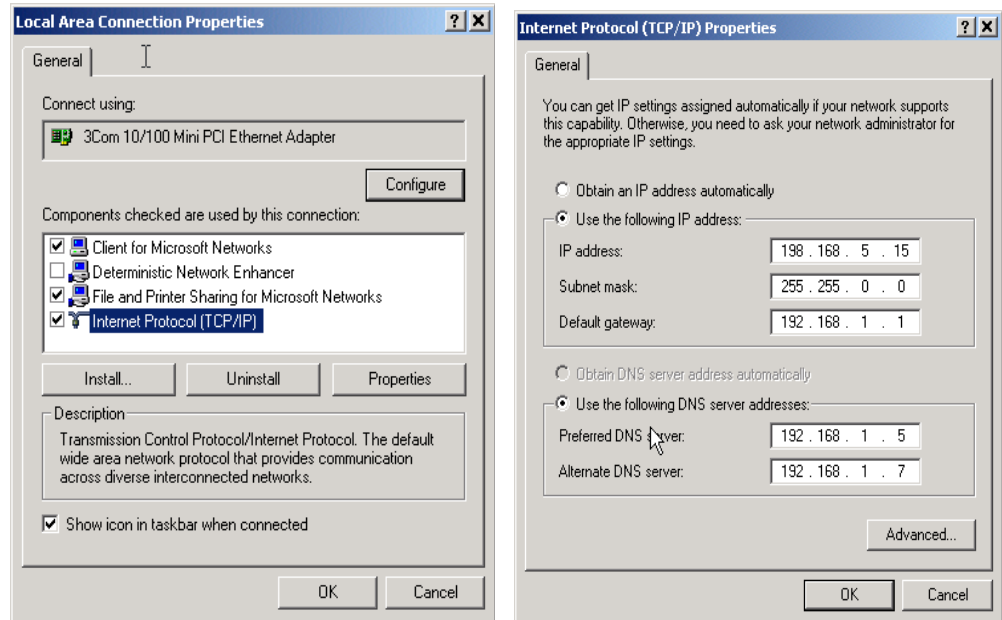

Figure 2-1 Windows 2000 IP Address Setting

WARNING: You cannot rely on executing an “ipconfig” command to tell you if you have a fixed IP address. Often errors have occurred due to the fact that what appeared to be a fixed address was none the less a dynamic IP address and communications were lost when the Aperto device rebooted to set the parameters permanently.

Start the Application

Double-click on the “Advanced Installation Manager 1.0” (AIM) icon on your desktop. If it is installed properly, you should see the Authentication window, *Figure 2-2* shown below. Please note the buttons at the bottom of the window.

The AIM application is much like a wizard program. You may move to the next or previous window as you wish. Each time you move from window to window some process is performed for you.

WARNING: If the PC and the PW620 are not connected properly you will see the warning shown in the graphic below when you click on the next button.

If you feel you are connected properly between the PC and the PW620, see below for other errors.



Click on the Next button at the bottom of the window. You will move to the next window and AIM will begin communications with the PW620. It will read the type of IDU so that it may proceed correctly through this installation.

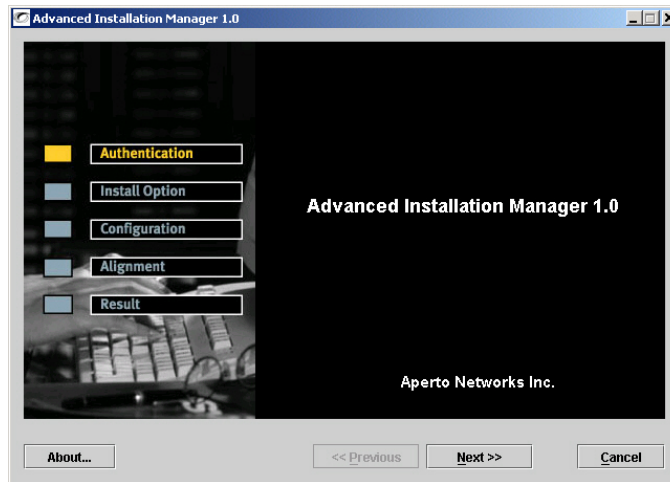

Figure 2-2 Authentication Window

Choose the Installation Mode

You should now be at the Installation Option Window as shown in *Figure 2-3* below. You may now choose Setup to perform an Installation viewing and changing the parameters or Continue to use the parameters that are already stored in the PW620 from a previous installation attempt. If in doubt, choose the Setup option. Select the Installation Mode Option and then click on the Next button at the bottom of the window. If you chose the Setup Option, continue the instructions below. If you chose the Continue with setup

Option, skip then next step and go to the Continue Configuration Description. As you continue on the next window, AIM will get the current parameters from the PW620.

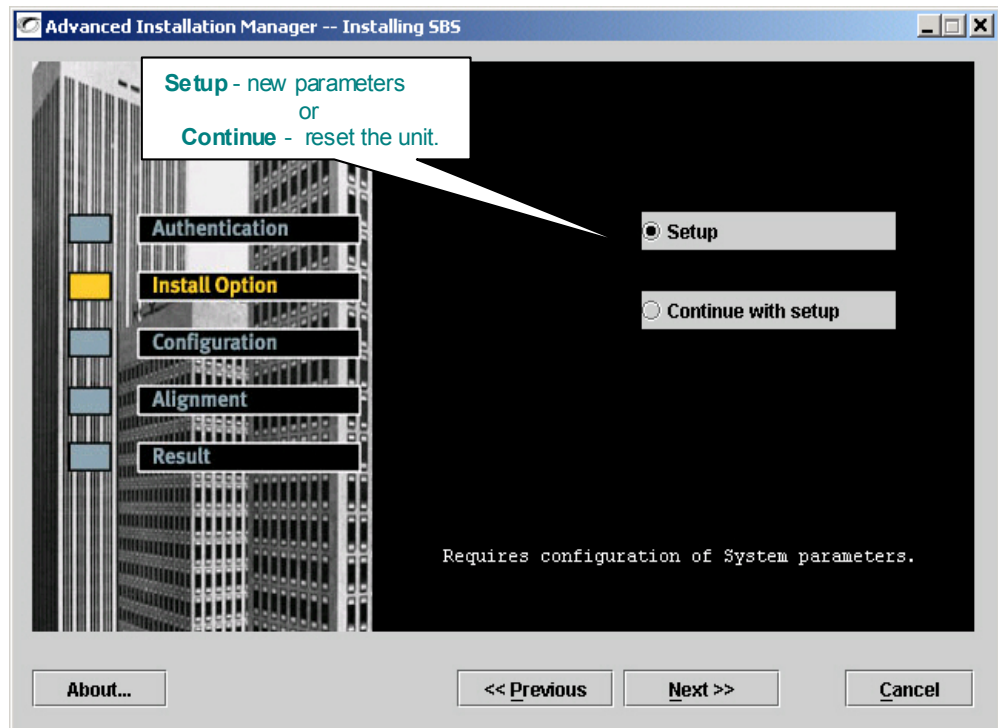

Figure 2-3 *Installation Option Window*

Fill Out the Configuration Parameters

If you are here, you chose the Setup Installation mode. If you chose the Continue with setup option please skip to the next step.

The information shown to you in the Configuration Window was retrieved from the attached Aperto unit. If you have any reason to believe these are not correct, click on the Previous button and then on the Next button to get back to this screen and refresh the data.

You should now be at the Installation Option Window as shown in *Figure 2-4* below. Most of the values are filled in for you. The MAC address should be the same as that on the label in the back of the IDU.

If this is the first time, the window will look differently than in each successive installation. That is because the frequency band and channel width are only requested once. Please use the selection box following the “Frequency (MHz)” label to select the UNII5.8GHz

(5.725 - 5.825 GHz) value. It is suggested that you leave the channel width to the current selection of 6.

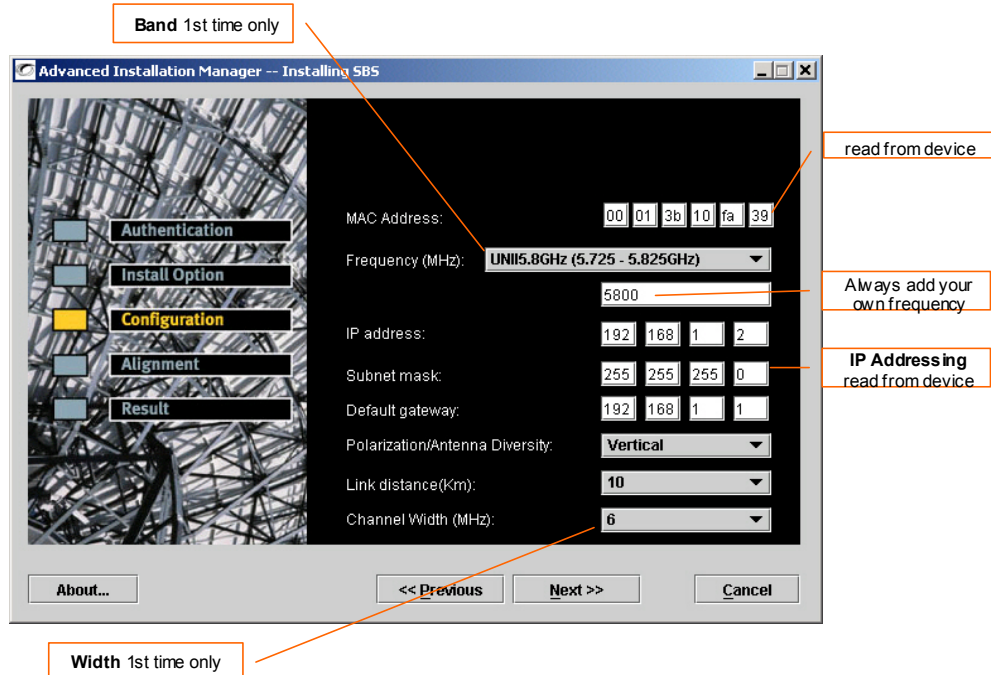

Figure 2-4 Configuration Window from Setup

Please select an appropriate channel center frequency. The values range from 5728 to 5822. This is the center of a 6MHz channel. You may move the frequency up or down within that range in 1 MHz values.

Hopefully, you have planned carefully and have an appropriate value in mind. Aperto has no way of offering a suggestion for a default value appropriate to your area. As soon as you configure the PW620, it will begin transmitting.

Choose the IP address, Subnet mask, and Default gateway appropriate for your PW620. This should be a unique address in the network to which you attach the PacketWave 600 series units. It is important to remember that the IP subnet you choose will include an address for the PW610. Thus, both units of your PacketWave 600 series should have a unique address in the same subnet.

The antenna polarity of the PW620 should match that of the PW610. Antenna polarity and diversity will be discussed later in this document. The “Vertical” default is a good choice.

Link Distance should be set to the correct distance or the next higher equivalent. Values of 10,20,30,40, and 50 KM are available.

AIM will calculate the correct frame parameters for the values you have entered.

Please skip ahead to the Results step.

Accept the Default Configuration Parameters

If you are here, you chose the Continue with setup Installation mode. If you chose the Setup option please skip to the next step.

You should now see a window as shown in *Figure 2-5*. AIM has retrieved the MAC address of the Aperto unit. If you believe this is incorrect, use the Previous and then the Next buttons to proceed to the previous window and then back again.

If the information is correct, click on the next button.

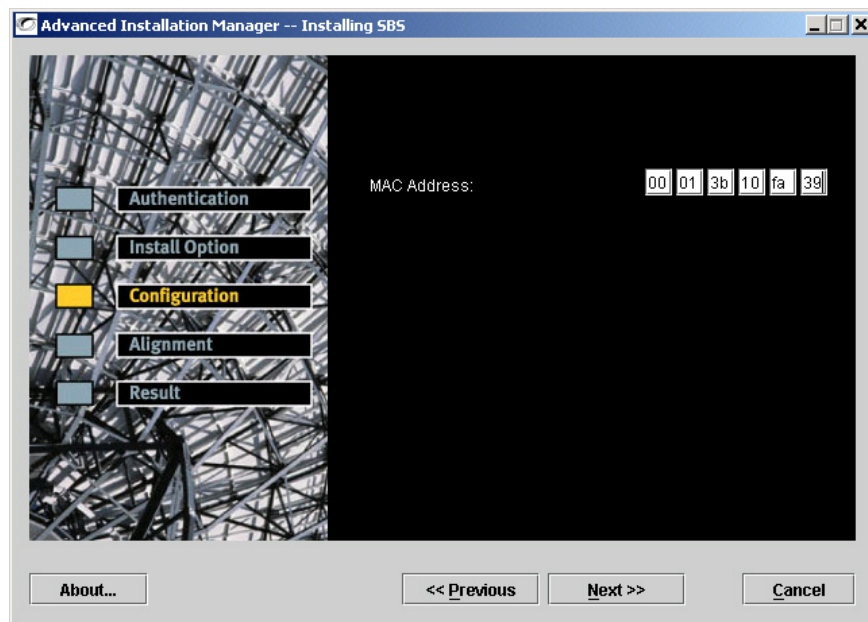

Figure 2-5 Configuration Window - Continuing with Installation

Allow AIM to Configure the PacketWave

When you click on the next button from either the Setup or Continue with Setup Configuration window, AIM sends the parameters to the Aperto PW620.

AIM signifies the completion of the work by displaying a Result window as show in *Figure 2-6*.

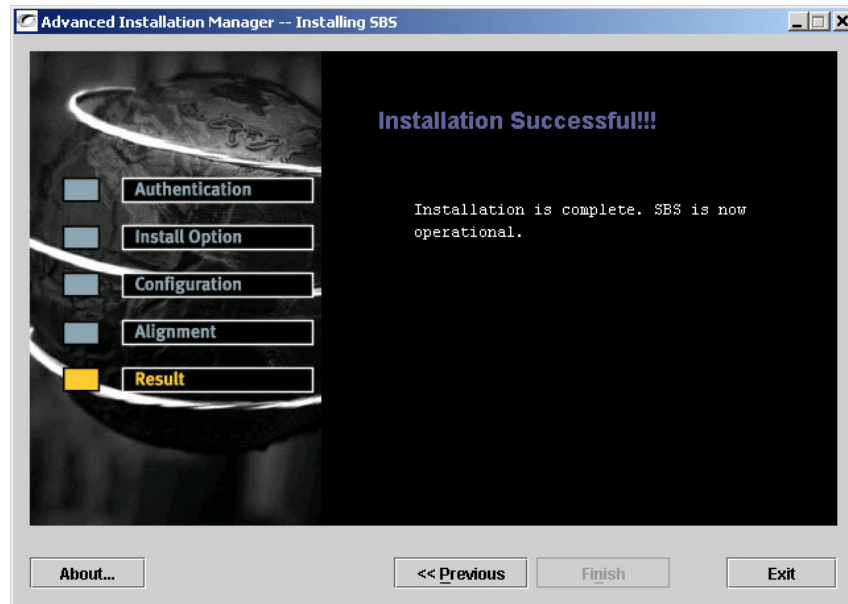

Figure 2-6 *Result Window of the Installation of a PacketWave 620*

You may now use the Previous button successively to return to the Authentication window to proceed to the installation of the PW610 or you may click on the Exit button to end the program. AIM has a warning to ask if you really want to exit. This is shown in the graphic below

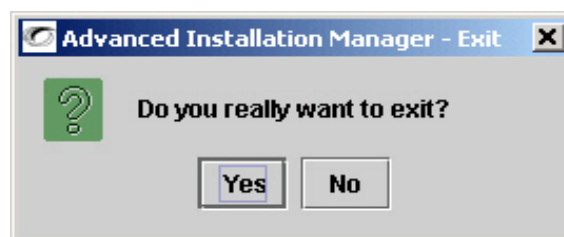

Figure 2-7 *Exit Warning Window*

WARNING: The high speed bridge mode technology of the PacketWave 600 series causes it to remember which interface was connected to a particular PC. When you use AIM to configure the PW620, the PW620 believes the PC is connected to its LAN interface. If you use the same PC to run AIM on the PW610, the system may get confused since the PC will now appear

on the wireless interface of the PW620. These entries time out in 1 hour. If you wish to use the same PC to run the AIM application on the both of the PacketWave 600 units (PW620 & PW610) within the same hour, it is best to disconnect the PC from the unit and power-cycle it.

Installing the PacketWave 610 - PW610

The installation of the PW610 is similar in many ways to the installation of the PW620. Many of the input parameters are the same. The biggest difference is that you use AIM to aim the antenna for the best possible signal. Everything you need is supplied in the AIM application. You don't have to guess at the optimal signal level nor do you need expensive equipment. The PacketWave 600 series not only helps you get the best signal, but also includes standard communication test to insure the equipment is working properly.

To install the PW610 you need to perform the following steps

- Connect the PC and the PW610
- **Start the Application**
- **Choose the Installation Mode**
- **Fill Out the Configuration Parameters or Accept the Default Configuration Parameters**
- Allow **AIM to Configure the PacketWave**
- Align the Antenna
- Allow AIM to Perform the Installation and Through-put Tests
- **View the Results and** Re-align the Antenna if Necessary
- **Exit the AIM Application**

Connect the PC and the PW610

Connect your PC to the PW610 in the same way you did with the PW620. Follow the example of *Figure 2-1* on *page -3*.

Start the Application

If you exited the AIM application, restart it just as you did for the PW620. If you did not exit the application, click on the Previous button successively until you reach the Authentication Window as shown in *Figure 2-2* on *page -4*. Once on this page, make sure the PC is connected to the PW610 and click on the Next button. At this point AIM will query the Aperto unit and determine it is a PW610.

Choose the Installation Mode

The installation modes of the PW610 vary from that of the PW620. You will note that there is now a Test Only mode. The first two modes are the same with either the PW620 or the PW610. Test Only mode provides a ping and through-put test that is non-destructive. *Figure 2-8* below shows the three options. choose one and click on the Next button.

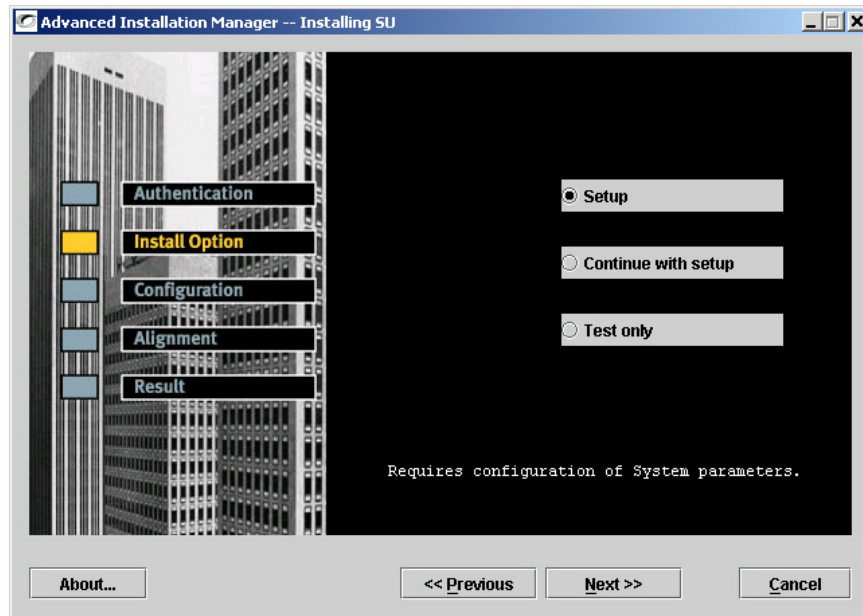

Figure 2-8 Install Option Window for the PW610

Fill Out the Configuration Parameters

You come to the Configuration Parameters window as seen in *Figure 2-9* because you selected Setup as your Install Option. If you chose the Continue with setup, skip to the next step.

As you can see from *Figure 2-9* below, the configuration parameters of the PW610 are much the same as the PW620. The screen's appearance is simplified due to the fact that the frequency band and channel are not presented. Aperto assumes that once this has

been selected for a system, the questions no longer need to be asked. The rest of the screen is also simplified also.

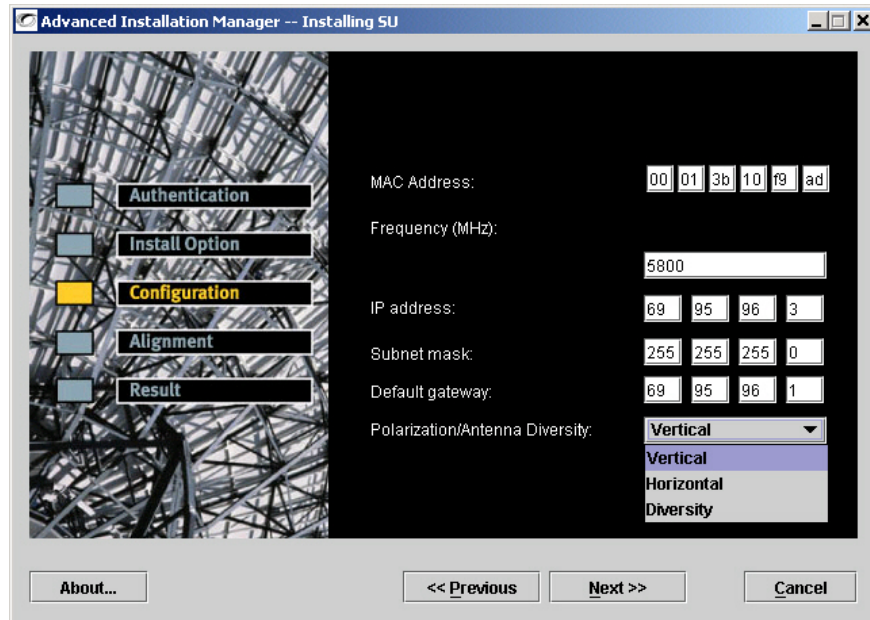

Figure 2-9 Configuration Window for the PW610

Enter the same frequency as you did on the PW620 configuration. These must match exactly.

Enter the IP address, subnet mask, and default gateway of the PW610. Remember this IP address should be in the same subnet as the PW620 or the ping and through-put tests of AIM will not complete.

Finally, enter the antenna polarity. Here are the general rules:

- The PW620 is set to Vertical; set the PW610 to Vertical
- The PW620 is set to Horizontal; set the PW610 to Horizontal
- The PW620 is set to Vertical with diversity or Horizontal with diversity; set the PW610 to diversity.

A more complete description of diversity is given later.

Click on the Next button to proceed and skip the next step and proceed to Antenna Alignment;

Accept the Default Configuration Parameters

You came to this step because you chose Continue with setup. If you chose Setup as your install option, please skip ahead to the next step.

This step is exactly the same as with the PW620 so please refer to *Figure 2-5* on *page -7* for the correct instructions. Click on the Next button

Allow AIM to Configure the PacketWave

AIM now uses the information you gave (or the information stored in the Aperto unit if you came with the Continue with setup option) to configure the Aperto unit. AIM will send all of the parameters you entered and some calculated parameters to the Aperto unit.

WARNING: **One of the items AIM sends to the Aperto unit is a calculated IP address and subnet so AIM can communicate with the Aperto unit using standard TCP/IP. If you begin the alignment step and do not terminate it successfully, the IP address of the PW610 will remain with the address calculated by AIM, not the address you gave in the AIM parameters. Only after a successful completion of antenna alignment will the IP address be as you entered.**

The PW610 will be reset and it will go into antenna alignment mode. Once the PW610 is ready for antenna pointing, AIM will proceed to the alignment window automatically.

Align the Antenna

When the antenna is ready to be aligned, the window as shown in *Figure 2-10* below.

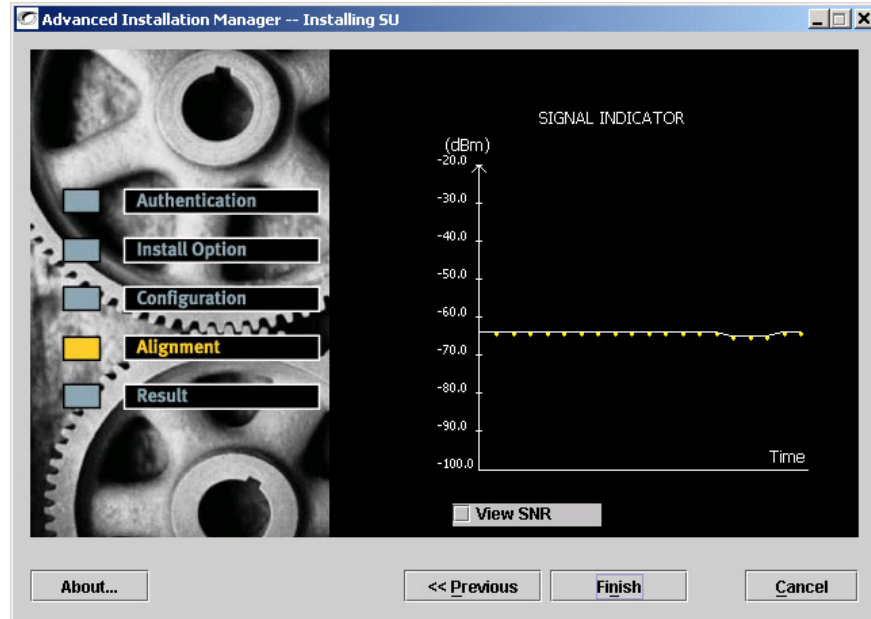

Figure 2-10 Alignment Window of PW610 - First Step

Move the antenna to point up or down or right to left to maximize the signal strength as shown on the graph on the right side of the window. Values greater than -95 dbm will work in the slowest speed on the line. Values above -78 will work at the highest speed.

Once this value is maximized, click on the “View SNR” button to reveal the full window as shown in *Figure 2-11*. Values in the red area are not good. Values in the yellow area are

acceptable. Values in the green area are best. The author has seen a value of 10db of SNR, most definitely in the red area, successfully at the lowest speed.

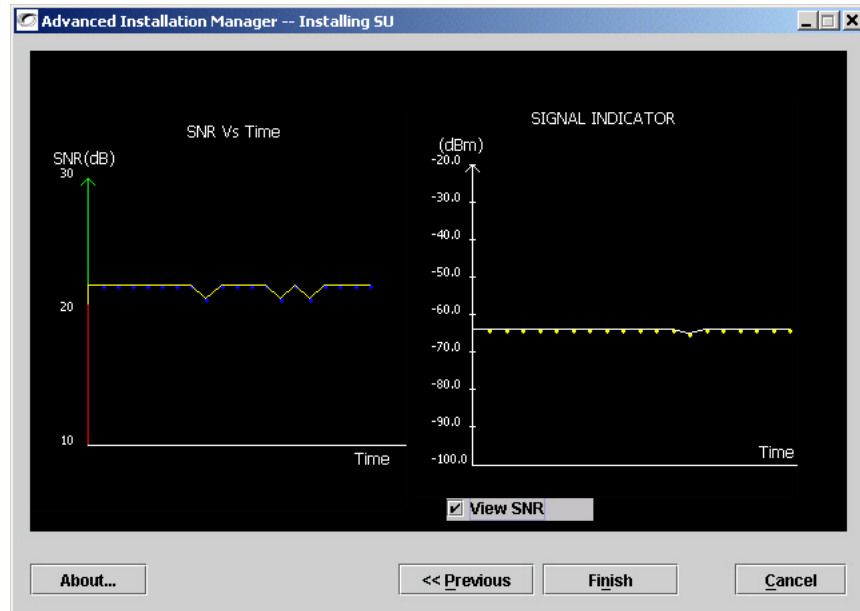

Figure 2-11 Alignment Window of the PW610 - Full Window

Once again, adjust the antenna to point up or down, right or left until the maximum signal strength and maximize the signal to noise indicator (SNR). When you have done all that is possible, click on the Finish button.

Allow AIM to Perform the Installation and Through-put Tests

A series of popup windows will display showing you the progress of the application. Remember, that the unit must perform automatic transmission strength and radio gain, become operational, and perform IP stability testing before the application is complete. The following is the description of the popup windows as the system progresses. First,

parameters are sent to the PW610. Next the unit is reset. This takes a few minutes of time and you will see the popup window below.

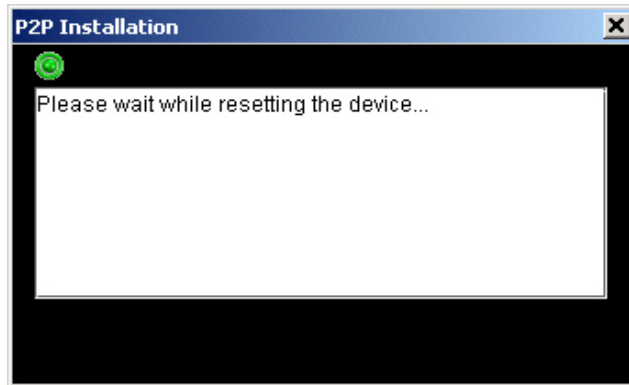

The following window will display when the PW610 has reset and it receives the first synchronization from the PW620. It is periodically refreshed and shows the current state of the unit and the radio gain and attenuation from maximum transmission.

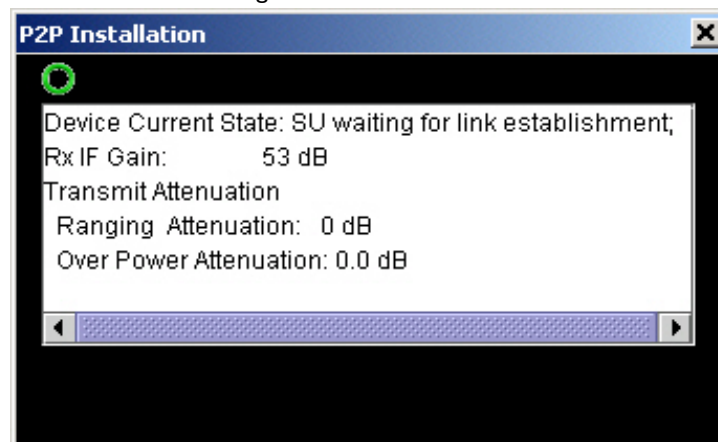

There is nothing you can do to help or hinder this process. It will proceed automatically. AIM requests a ping test between the PW600 units once the unit becomes operational. Then the following will be displayed. This is to signify that the unit is operational and the ping tests have completed. It make take a few minutes to complete the throughput tests

depending upon the signal characteristics. If it takes more than 10 minutes, click on the Exit button.

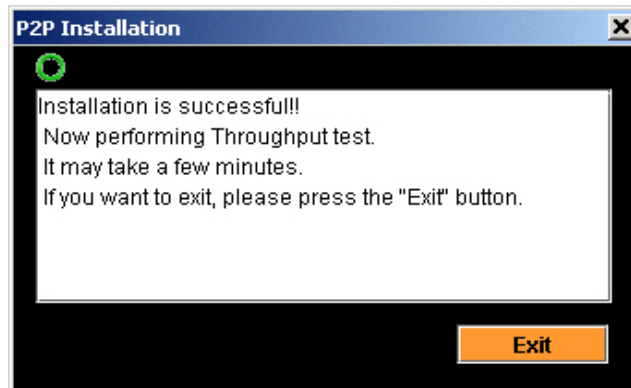

View the Results and Re-align the Antenna if Necessary

Figure D-13 shows an example of the Results Window after the antenna alignment is finished. Results of the Ping test and the Throughput test are displayed. The ping results are the same as most ping applications. The throughput test is the result of the data throughput of an FTP transfer of 1 megabit of data transferring up and down the wireless link.

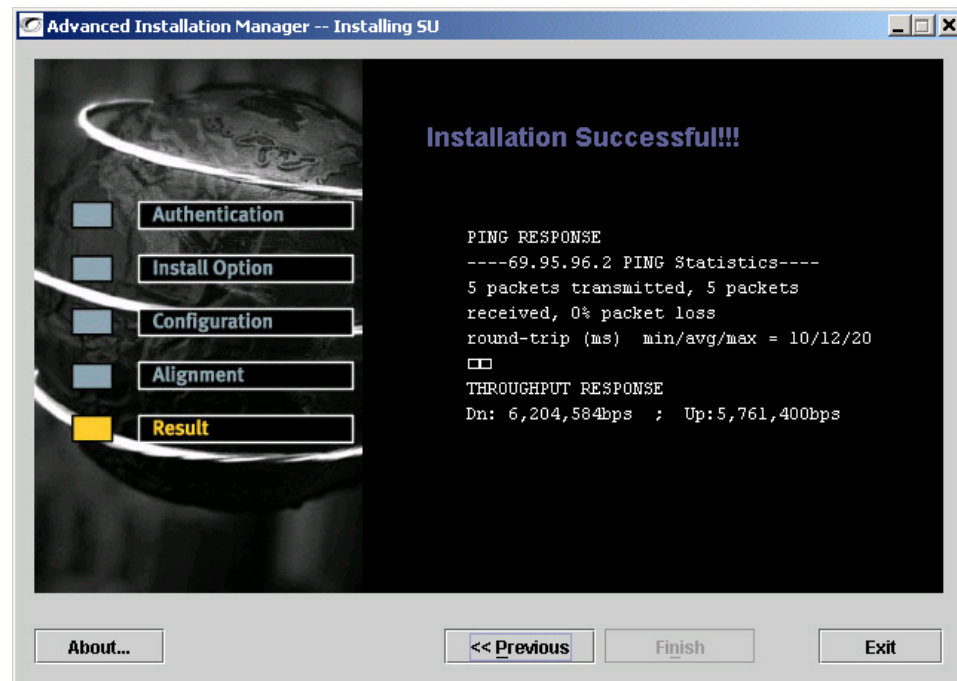

Figure 2-12 **Results Window of the PW610**

These results and RF transmission results are recorded in a text file with the name of the IP address in the file in which AIM is loaded (normally C:\aim). Each time the Setup or Test function successfully executed this file is updated.

View the Results and Re-align the Antenna if Necessary

It is important to check the RF and IP transmission results to see if you have the best possible wireless connection. If these results are not acceptable, click on the previous button to the installation option window, choose the Continue with Setup option and click on next and then final buttons to re-align the antenna and retest.

Exit the AIM Application

To exit, click on the Exit button. An exit confirmation window will appear as shown in *Figure D-14* on page -18.

Running a Non-destructive Test

You can run a non-destructive test at any time from the LAN port of the PW610. Connect the PC to the PW610 and start the AIM application as described above. At the Installation Option Window, select Test only and click on the Next key. You can pick the number of megabytes to be transferred from the selection window shown below in *Figure 2-13*. Click on the Next button after choosing the size of the test.

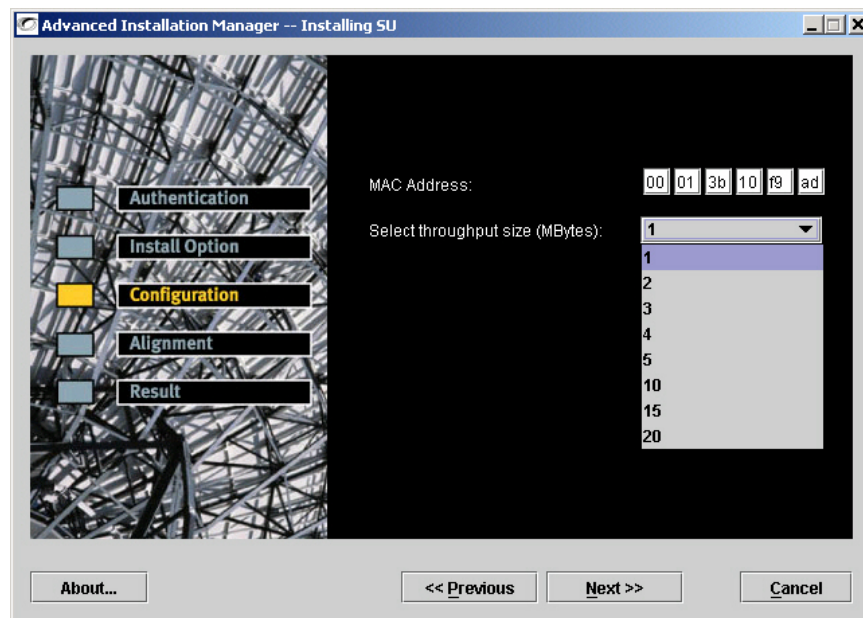

Figure 2-13 **Test Configuration Window**

The same result screen as *Figure 2-12* on *page -16* will show and the result text file will be updated.

Antenna Polarity

What are the options?

The Aperto Series 600 point-to-point system runs in two modes; fixed polarity mode and diversity mode.

The polarity is Vertical or Horizontal. Vertical is usually a better choice in that it provides a signal over longer distances. That is not due to the strength of the signal since both Vertical and Horizontal are the same strength. This characteristic is due to the type of interference from environmental factors. If there is interference from other signals, Horizontal may be a better choice.



Antenna Diversity allows the PW610 to check both the Vertical and Horizontal signals the use the stronger of the two. The radio/antenna is installed at a 45 degree angle and appears to be a diamond shape rather than a rectangle. This is done so the Vertical and Horizontal signals are more available to the PW610. The PW620 will increase the number of SYNC packets on the wireless frame when it is placed in diversity mode so that the synchronization may be seen more regularly by the PW610. The SYNC packets are either sent Vertically or Horizontally, thus the settings of Vertical diversity and Horizontal diversity on the PW620.

When to use Antenna Diversity

Antenna Diversity does have a disadvantage when it comes to signal strength. We lose 3db of signal strength when we run in diversity mode. Therefore, it is not appropriate to enable diversity when long distances of weak signals are encountered. When maximum signal strength is required, use either Vertical or Horizontal polarity without diversity.

Antenna Diversity should be used when there is multipath or signal distortion due to physical interference such as buildings or trees or other vegetation.

Multipath is caused by a signal bouncing off of reflective surfaces. The antenna receives many signals from the same source frame, but due to their reflection, they are delayed and thus many offsetting signals. Aperto utilizes many techniques to isolate the strongest signal in a multipath environment, one of which is Antenna Diversity. Another way to deal with the multipath environment is antenna alignment of which you are already familiar. If the SNR value is low after pointing the antenna as best you could in a non-diversity mode, you should re-mount the PW610 antenna and try diversity mode.

Another indication that you should try diversity mode is that after your best attempt at antenna pointing you receive disappointing throughput results.

Finally, you should try diversity mode if you feel that even though your SNR values are high and the throughput has appropriate results today, this may change in the future. An example of this is that you install in the Winter when trees have few or no leaves, but you know that come Spring the leaves will grow back causing problems. It is best to utilize diversity mode now in anticipation.

Installation with Antenna Diversity

Here is how you install antenna diversity now that you have determined you need it

- Leave the PW620 mounted in a rectangular fashion such that the antenna bracket is at 90 degree angles to the antenna.
- Insure that the mounting mast of the PW620 is plumb (at exact vertical).
- Choose either Vertical or Horizontal polarity with diversity using AIM.
- Change the antenna mounting bracket of the PW610's antenna such that it is at a 45 degree angle to the antenna
- Insure that the mounting mast of the PW610 is plumb.
- When AIM enters the Alignment phase, you will see two signal strengths, horizontal and vertical. You should maximize their value and insure that both the horizontal and vertical signal strengths are equal. To perform the alignment of the horizontal and vertical signal strengths, you should plumb the antenna as appropriate to make these signals equal. An example of AIM's Alignment response is shown in *Figure 2-14* on *page -20*.

- Once aligned, check the IP integrity and throughput as before. Re-align if necessary.

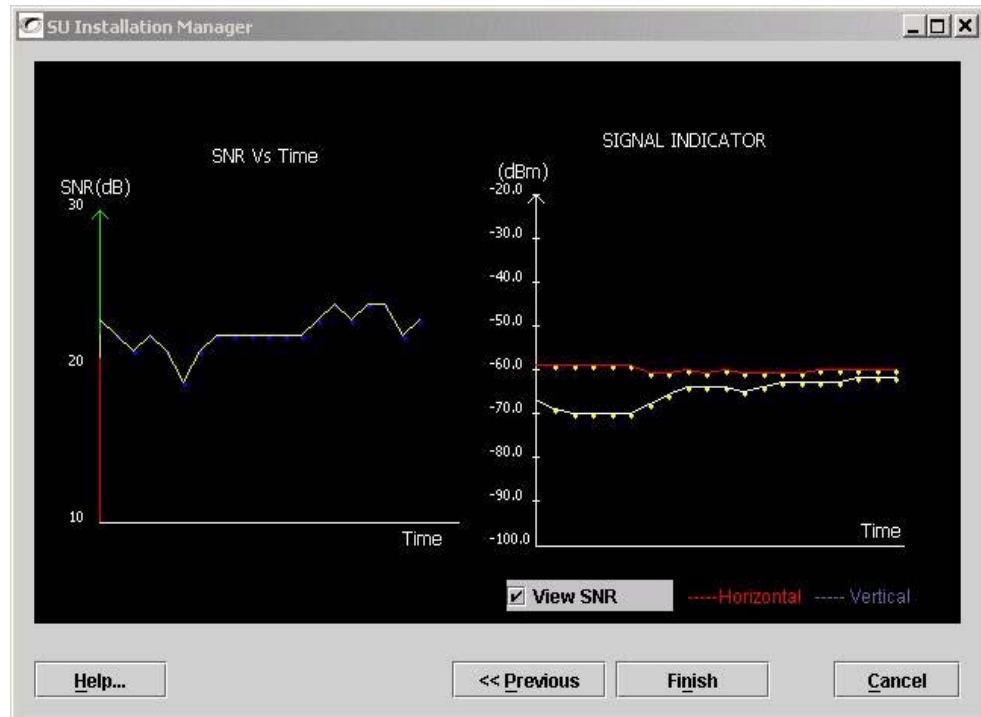

Figure 2-14 Alignment with Diversity Enabled

Problem with Signal Indicator in Installation Manager

When using Installation Manager, if the signal does not move up from the bottom of the Signal Indicator graph (i.e., shows -100 dBm), follow the instructions below.

If the installation has line-of-sight to the Base Station antenna, you should know the general direction to point the Outdoor Unit. Start in that direction. Move the Outdoor Unit every few seconds until you see the Signal Indicator line raises at least once. Once it raises, slow the movement of the antenna, checking the SIGNAL INDICATOR as well as the SNR. If nothing appears after 2 to 3 minutes, it is best to click the Previous and then the Next buttons to reset sequence.

If the installation is not line-of-sight, either search for a first synchronization from the base station (as indicated by the rise of the Signal Indicator line) or just pick a direction to point your antenna. In either case, the SU will begin to adjust your 10 MHz reference clock. After two minutes, either the SU has found synchronization, or it needs to be reset by clicking on the Previous and then the Next buttons. If you chose to leave the antenna in a static direction, move that antenna 20 degrees after it has been reset.



Base Station Unit Web GUI

Each PacketWave 620 Base Station Unit and PacketWave 610 Subscriber Unit includes a Java-based graphical user interface (GUI) which runs on a standard Web browser (Netscape 4.74 or Internet Explorer 5.0 recommended). Functions of the Web GUI include:

- Viewing network connectivity.
- Monitoring status and performance.
- Reviewing configuration.
- Making configuration changes.
- Uploading configuration changes to the Base Station Unit and Subscriber Unit permanent memory.
- Resetting Base Station Units and Subscriber Units.

This chapter describes the Base Station Unit Web GUI.

Accessing the BSU's Web Interface

To access the Base Station Unit's Web GUI:

1. On a computer with IP access to the Base Station Unit, open Netscape 4.74 or Internet Explorer 5.0. (Other browsers could show some anomalies.)
2. Enter the URL, *http://<BSU IP address>/*. The logon page will appear, as shown in *Figure 3-1*.



Figure 3-1 BSU Web GUI Logon Screen

3. Select the **ISP** user name. **Debug** logon is reserved.
4. Enter the correct password (case-sensitive).

NOTE: The default password is **isp**. For security, this password should be changed via the Web GUI.

5. Click on the **Logon** button or press Enter key.
6. If the browser prompts that it needs to load a plug-in, allow it to do so.
7. Wait for the Web GUI home page to open, as shown in *Figure 3-2*.

The Web GUI pages share the basic elements identified in *Figure 3-2*.