

QUICK SETUP GUIDE

LD3249

What's in the box

- Remote Control
- 2 X AAA Batteries
- Power Cord
- User Manual
- Quick Setup Guide



Contact Customer Service

Before contacting your retailer, read the User Manual thoroughly. This Quick Setup Guide will answer the most frequently asked questions for setup, installation and use. Take a moment to register your product at www.apexdigitalinc.com.

We encourage you to visit us at www.apexdigitalinc.com for answers to your questions. Access our 24 hour Customer Support and FAQ's page or receive personalized email technical support. Order accessories online or speak to a customer support representative at (866)427-3946.

TV Rear Panel

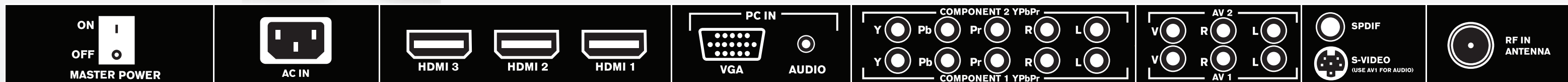

The rear panel illustration is provided to show video INPUT connections (and SPDIF digital audio output) available to you. Reference the INPUT labels then determine the connections best suited to hook up your HD and non-HD equipment. See the user manual for complete details.

RF Input Connection

- Use a rooftop or amplified indoor antenna to receive local HD signals over the airwaves. For assistance in choosing the correct one for your area, visit www.antennaweb.org
- CableTV - Subscribe to HDTV programming through your local cableTV provider. An HD cable box is required.
- Satellite - Subscribe to HDTV programming through DirecTV or Dish network. An HD set top box is required.
- Connect the RF coaxial (75 ohm) cable from your existing TV antenna or the cable wall outlet to the RF input located on the TV's rear panel.
- Run **Channel Auto Scan** (refer to next step) to receive available local digital TV channels into the television's tuner.

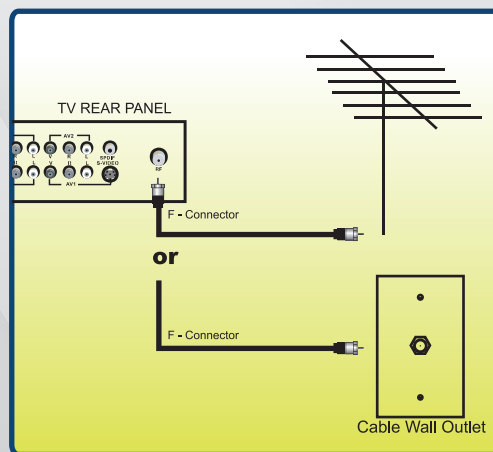

Initial TV Setup

After you have initially connected your TV antenna or cable (no set top box), turn the television ON. A screen will display asking you to run a **Channel Auto Scan**. It is here where you will select AIR/CABLE options to search and receive available local digital channels.

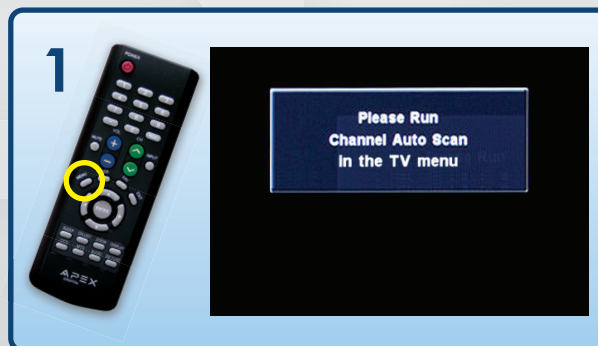

- Press the **MENU** button on the remote control.

NOTE: For cable or satellite users with no TV antenna, there no need to run Channel Auto Scan. Connect your cable or satellite set top box to one of the available inputs on the TV for viewing.



- Using the ◀▶ arrow buttons, scroll to highlight **TV** menu.
- Press the down ▼ arrow button to highlight **AIR/CABLE**, then press ◀▶ arrow buttons to select.

NOTE: Select AIR when connecting an indoor/outdoor antenna. Select **CABLE** when you subscribe to a pay television service (with no set top box) and the television is connected through the RF input.



- Press the ▼ arrow button to select **Auto Scan**.
- If **AIR** was selected in the previous step, press the right ▶ arrow button twice to start Auto Scan.
- If **CABLE** was selected in the previous step, press the right ▶ arrow button. **CABLE SYSTEM** will display and be highlighted. Press the right ▶ arrow button to select **STD > IRC > HRC > Auto** (Auto is recommended).
- Press the down ▼ arrow button to highlight **Auto Scan** and press **ENTER** to start Auto Scan.

HDMI Input Connection

BEST Video Performance

Use of this pure digital technology offers enhanced high definition video and digital audio all via a single cable.

There are three (3) HDMI inputs available for use with HD Set Top Boxes, gaming consoles and HD DVD / Blu-ray players.

How to Connect HDMI

- From your external digital A/V equipment, connect an HDMI cable from the HDMI output to the HDMI input on the TV's rear panel.

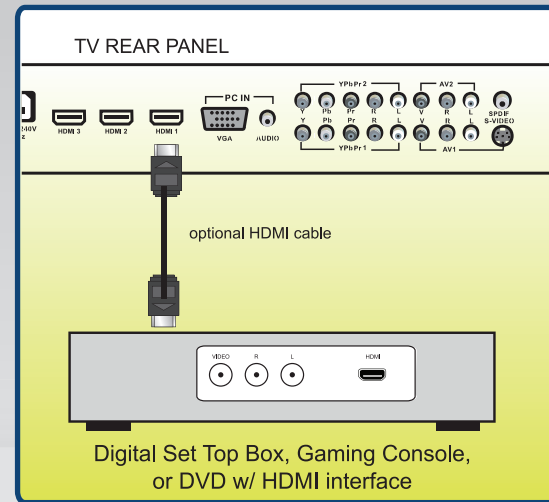

Component Input Connection

BETTER Video Performance

There are two (2) YPbPr component video and audio inputs for use with set top boxes, gaming consoles, and DVD players.

How to Connect Component

- When connecting A/V equipment to your television, match the colors of the connecting jacks (Video: Blue, Green, Red; Audio: White/Red)
- Connect optional component video cables (blue, green, red) from the video output jacks (Y, Pb, Pr) on your external A/V equipment (ie: DVD Player, set top box) to the YPbPr1 and/or YPbPr2 input(s) on the TV's rear panel.
- Connect white/red audio cables for sound from the audio (L/R) output jacks on your external A/V equipment (ie: DVD Player, set top box) to the YPbPr1 or YPbPr2 L/R input(s) on the TV's rear panel.

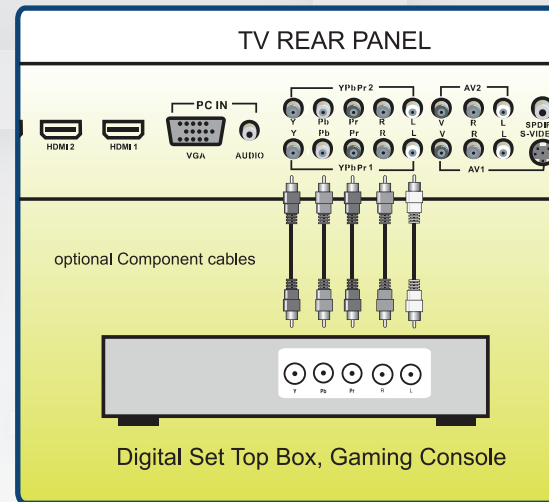

Composite/S-Video Connection

GOOD Video Performance

Composite and S-Video output jacks are available on most set top boxes and DVD players. (Component or HDMI connections are recommended for best performance, if possible).

How to Connect Composite

- When connecting A/V equipment to your television, match the colors of the connecting jacks (Video: Yellow; Audio: White/Red)
- Connect the yellow video cable from the video output jack on your external A/V equipment (ie: DVD Player, set top box) to AV1 or AV2 input on the TV's rear panel.
- Connect the white/red audio cables for sound from the audio (L/R) output jacks on your external A/V equipment (ie: DVD Player, set top box) to the AV1 or AV2 (L/R) jacks on the TV's rear panel.

How to S-Video

- Connect an optional S-Video cable from the S-Video output jack on your external A/V equipment to the S-Video input on the TV's rear panel.
- Connect the white/red audio cables for sound from the audio (L/R) output jacks on your external A/V equipment to the AV1 (L/R) input on the TV's rear panel.

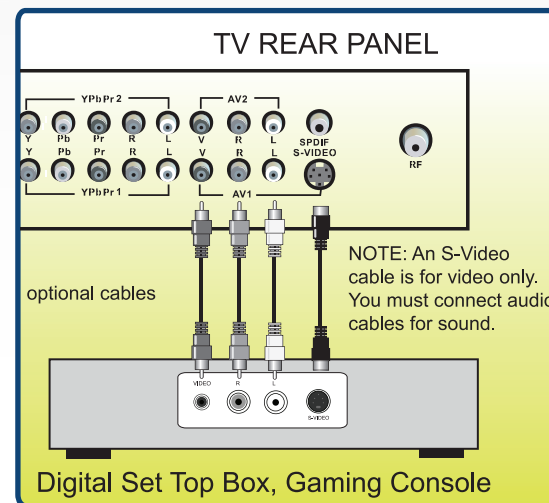

Troubleshooting

Symptom	Possible Solutions
Cannot receive certain channels through the antenna	<ul style="list-style-type: none"> Use the Channel Auto Scan function to add the channels not included in memory. See page 17. Readjust your antenna and retry Channel Auto Scan. Signal from the TV station may be weak in your area.
No color	<ul style="list-style-type: none"> Check the video installation of your external A/V equipment. See pages 11-14
Video noise or choppy picture	<ul style="list-style-type: none"> Readjust antenna. Keep TV away from noise sources, neon lights, and microwave appliances.
TV blocked on certain channels	<ul style="list-style-type: none"> Use the automatic scanning method to add the channels not included into the memory. See page 17. Check whether channel was deleted. See page 26. Check parental control settings. See pages 24, 25.
Cannot use certain functions	<ul style="list-style-type: none"> If the item chosen in a menu is shown in gray text, that item cannot be selected in the current input.
No sound	<ul style="list-style-type: none"> Check that connected audio cables are completely inserted. Verify you have selected the correct audio source from your amplifier. See pages 15, 16. Mute function maybe enabled, press mute on the remote.
Black box on screen	<ul style="list-style-type: none"> The "Text" option is enabled and no text is available. Turn off CC in the Setup menu under Closed Caption. See page 22
No power	<ul style="list-style-type: none"> Batteries in the remote control may need replacing. Re-attach AC plug to wall outlet. Check that the Master Power switch is ON. See page 9.
No picture	<ul style="list-style-type: none"> Digital TV channel signal maybe weak, try another channel. Press input button repeatedly to select connected A/V equipment. Re-connect the antenna or cable wiring.
Remote control does not function	<ul style="list-style-type: none"> Replace batteries with new ones. Check that battery polarity is correct. Point remote directly at the TV. See page 6.

LCD 32 HDTV

32" Class HDTV (31.5" Diagonal Viewing Area)