

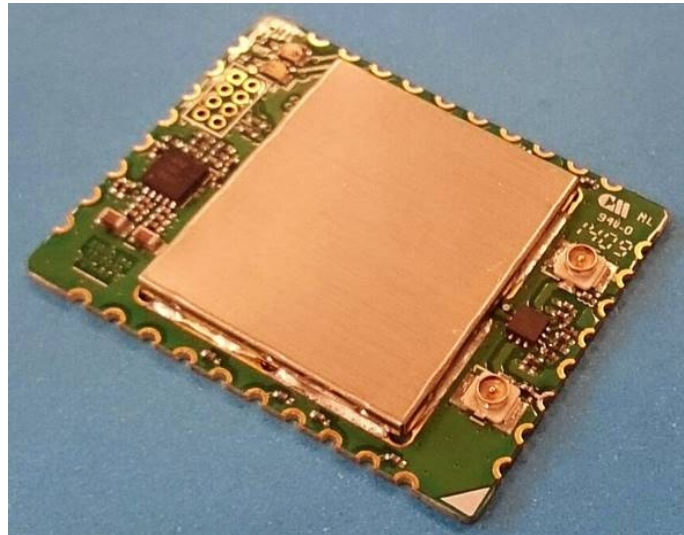

## SENTINEL-SENSE PCB-915RM-SD

### **Installation & Operation Manual-041491**



## **COPYRIGHT ACKNOWLEDGEMENTS**

The contents of this document are the property of Applied Wireless Identifications Group, Inc. (AWID) and are copyrighted. All rights reserved. Any reproduction, in whole or in part, is strictly prohibited. For additional copies of this document please contact:

AWID

18300 Sutter Blvd

Morgan Hill, CA 95037

<http://www.AWID.com>

The information contained herein has been carefully checked and is believed to be accurate, no responsibility is assumed for inaccuracies. AWID reserves the right to make changes without prior notice. This document is not covered by any warranty either expressed or implied. Any comments, corrections or additions to the contents of this document should be directed to AWID at the above address.

Copyright 2014 AWID, Printed in USA.

All other trademarks are the property of their respective owners.

## **FCC COMPLIANCE**

This device complies with Part 15 of the FCC Rules. Operation is subject to the following two conditions: (1) This device may not cause harmful interference, and (2) this device must accept any interference received, including interference that may cause undesired operation.

This equipment has been tested and found to comply with the limits for a Class B digital device, pursuant to Part 15 of the FCC Rules. These limits are designed to provide reasonable protection against harmful interference in a residential installation. This equipment generates, uses and can radiate radio frequency energy and, if not installed and used in accordance with the instructions, may cause harmful interference to radio communications. However, there is no guarantee that interference will not occur in a particular installation. If this equipment does cause harmful interference to radio or television reception, which can be determined by turning the equipment off and on, the user is encouraged to try to correct the interference by one of the following measures:

- Reorient or relocate the receiving antenna.
- Increase the separation between the equipment and receiver.
- Connect the equipment into an outlet on a circuit different from that to which the receiver is connected.
- Consult the dealer or an experienced radio/TV technician for help.

FCC Caution: Any changes or modifications not expressly approved by the party responsible for compliance could void the user's authority to operate this equipment.



This transmitter must not be co-located or operating in conjunction with any other antenna or transmitter.

**Radiation Exposure Statement:**

This equipment complies with FCC radiation exposure limits set forth for an uncontrolled environment. This equipment should be installed and operated with minimum distance 20cm between the radiator & your body.

**This device is intended only for OEM integrators under the following conditions:**

- 1) The antenna must be installed such that 20 cm is maintained between the antenna and users, and
- 2) The transmitter module may not be co-located with any other transmitter or antenna.

As long as **2** conditions above are met, further transmitter test will not be required. However, the OEM integrator is still responsible for testing their end-product for any additional compliance requirements required with this module installed

**IMPORTANT NOTE:** In the event that these conditions can not be met (for example certain laptop configurations or co-location with another transmitter), then the FCC authorization is no longer considered valid and the FCC ID can not be used on the final product. In these circumstances, the OEM integrator will be responsible for re-evaluating the end product (including the transmitter) and obtaining a separate FCC authorization.

**End Product Labeling**

This transmitter module is authorized only for use in device where the antenna may be installed such that 20 cm may be maintained between the antenna and users. The final end product must be labeled in a visible area with the following: "Contains FCC ID: OGS915RMSD". The grantee's FCC ID can be used only when all FCC compliance requirements are met.

**Manual Information To the End User**

The OEM integrator has to be aware not to provide information to the end user regarding how to install or remove this RF module in the user's manual of the end product which integrates this module.

The end user manual shall include all required regulatory information/warning as shown in this manual.

## INDUSTRY CANADA COMPLIANCE

This device complies with RSS-210 of the Industry Canada Rules. Operation is subject to the following two conditions: (1) This device may not cause harmful interference, and (2) this device must accept any interference received, including interference that may cause undesired operation.

Ce dispositif est conforme à la norme CNR-210 d'Industrie Canada applicable aux appareils radio exempts de licence. Son fonctionnement est sujet aux deux conditions suivantes: (1) le dispositif ne doit pas produire de brouillage préjudiciable, et (2) ce dispositif doit accepter tout brouillage reçu, y compris un brouillage susceptible de provoquer un fonctionnement indésirable.

### **Radiation Exposure Statement:**

This equipment complies with IC radiation exposure limits set forth for an uncontrolled environment. This equipment should be installed and operated with minimum distance 20cm between the radiator & your body.

### **Déclaration d'exposition aux radiations:**

Cet équipement est conforme aux limites d'exposition aux rayonnements IC établies pour un environnement non contrôlé. Cet équipement doit être installé et utilisé avec un minimum de 20 cm de distance entre la source de rayonnement et votre corps.

**This device is intended only for OEM integrators under the following conditions: (For module device use)**

- 1) The antenna must be installed such that 20 cm is maintained between the antenna and users, and
- 2) The transmitter module may not be co-located with any other transmitter or antenna.

As long as **2** conditions above are met, further transmitter test will not be required. However, the OEM integrator is still responsible for testing their end-product for any additional compliance requirements required with this module installed.

**Cet appareil est conçu uniquement pour les intégrateurs OEM dans les conditions suivantes: (Pour utilisation de dispositif module)**

- 1) L'antenne doit être installée de telle sorte qu'une distance de 20 cm est respectée entre l'antenne et les utilisateurs, et
- 2) Le module émetteur peut ne pas être coïmplanté avec un autre émetteur ou antenne.

Tant que les **2** conditions ci-dessus sont remplies, des essais supplémentaires sur l'émetteur ne seront pas nécessaires. Toutefois, l'intégrateur OEM est toujours responsable des essais sur son produit final pour toutes exigences de conformité supplémentaires requis pour ce module installé.

**IMPORTANT NOTE:**

In the event that these conditions can not be met (for example certain laptop configurations or co-location with another transmitter), then the Canada authorization is no longer considered valid and the IC ID can not be used on the final product. In these circumstances, the OEM integrator will be responsible for re-evaluating the end product (including the transmitter) and obtaining a separate Canada authorization.

**NOTE IMPORTANTE:**

Dans le cas où ces conditions ne peuvent être satisfaites (par exemple pour certaines configurations d'ordinateur portable ou de certaines co-localisation avec un autre émetteur), l'autorisation du Canada n'est plus considéré comme valide et l'ID IC ne peut pas être utilisé sur le produit final. Dans ces circonstances, l'intégrateur OEM sera chargé de réévaluer le produit final (y compris l'émetteur) et l'obtention d'une autorisation distincte au Canada.

**End Product Labeling**

This transmitter module is authorized only for use in device where the antenna may be installed such that 20 cm may be maintained between the antenna and users. The final end product must be labeled in a visible area with the following: "Contains IC: 6449A-915RMSD"

**Plaque signalétique du produit final**

Ce module émetteur est autorisé uniquement pour une utilisation dans un dispositif où l'antenne peut être installée de telle sorte qu'une distance de 20cm peut être maintenue entre l'antenne et les utilisateurs. Le produit final doit être étiqueté dans un endroit visible avec l'inscription suivante: "Contient des IC: 6449A-915RMSD".

**Manual Information To the End User**

The OEM integrator has to be aware not to provide information to the end user regarding how to install or remove this RF module in the user's manual of the end product which integrates this module.

The end user manual shall include all required regulatory information/warning as shown in this manual.

**Manuel d'information à l'utilisateur final**

L'intégrateur OEM doit être conscient de ne pas fournir des informations à l'utilisateur final quant à la façon d'installer ou de supprimer ce module RF dans le manuel de l'utilisateur du produit final qui intègre ce module.

Le manuel de l'utilisateur final doit inclure toutes les informations réglementaires requises et avertissements comme indiqué dans ce manuel.

Table of Contents

**REVISION HISTORY ..... 7**

**1 INTRODUCTION..... 8**

    1.1 Special Features ..... 8

**2 SPECIFICATIONS ..... 9**

    2.1 Channel Frequency Table..... 9

    2.2 Connector Pin Assignment..... 10

    2.3 Form Factor ..... 10

**NOTE: READ AND USE THIS MANUAL.**

**NOTE: FAILURE TO FOLLOW THE INSTALLATION GUIDE MAY RESULT IN POOR PERFORMANCE OR EVEN CAUSE PERMANENT DAMAGE TO THE READER, THUS VOIDS THE PRODUCT WARRANTY.**



**REVISION HISTORY**

<b>Version No.</b>	<b>Revised By</b>	<b>Date</b>	<b>Sections Affected</b>	<b>Remarks</b>
1.0	AWID Engineering	12/2014	-	Initial version
1.1	AWID Engineering	1/2015	1	Editorial

## 1 INTRODUCTION

AWID's Sentinel-Sense PCB-915RM-SD is a Radio Frequency IDentification (RFID) reader module capable of working with most leading passive UHF passive tags. The reader module comes with a unique combination dual antenna ports, small size, and low power consumption. Its primary functions are in asset management and tracking, and fleet management, i.e., embedded applications for PoS, printers and other portable devices widely used in these markets.

PCB-915RM-SD is delivered with Firmware Version such as 10.xx.xx.

In order to operate an PCB-915RM-SD you will need the following:

- PC running Windows<sup>1</sup> XP or higher, CD-ROM drive
- Host software (AWID's demo software or your own custom software)

### 1.1 SPECIAL FEATURES

- EPC Global Class 1 Gen 2 Protocol
- Thin passive tags with long-range performance
- Low power consumption & compact design for portable & embedded applications
- Dual antenna ports for flexible arrangement & coverage
- 3.3 V (5.0V tolerable) Serial TTL logical interface

<sup>1</sup> Though PCB-915RM-SD can also be controlled from a non-Windows programming platform, AWID demo and FW upgrade programs are applications to run in Windows.



## 2 SPECIFICATIONS

Input voltage	+4.0 ~ +5.0 VDC
Input current	150 mA
Protocol language	EPC Class 1 Gen 2
Read range	3 ~ 6 inch. (8 ~ 15 cm) antenna and tag dependent
RF connectors	2xU.FL (UMC) SWR<1.2 @50OHMs
Output power	+20 dBm max
Transmit frequency	902.60-927.40 MHz
Receiver frequency	902.60-927.40 MHz (Amplitude Modulated)
Hopping channels	125 Channels
Channel spacing	200 kHz typical
Hopping sequence	Pseudo random
Operating temperature range	-30° C to +65° C (-22° F to 149° F) (*)
Output data formats	3.3V TTL Serial
Interface Connector	4 x 2 header or 36 edge solder pads
Dimension	1.2"x1.0"x0.2"

(\*) depends on heat sink size

### 2.1 CHANNEL FREQUENCY TABLE

Frequency range: 902.60 ~ 927.40 MHz Minimum number of frequency channels: 125

CH	902~928	MHz	CH	902~928	MHz	CH	902~928	MHz	CH	902~928	MHz	CH	902~928	MHz
0	902.60	MHz	25	907.60	MHz	50	912.60	MHz	75	917.60	MHz	100	922.60	MHz
1	902.80	MHz	26	907.80	MHz	51	912.80	MHz	76	917.80	MHz	101	922.80	MHz
2	903.00	MHz	27	908.00	MHz	52	913.00	MHz	77	918.00	MHz	102	923.00	MHz
3	903.20	MHz	28	908.20	MHz	53	913.20	MHz	78	918.20	MHz	103	923.20	MHz
4	903.40	MHz	29	908.40	MHz	54	913.40	MHz	79	918.40	MHz	104	923.40	MHz
5	903.60	MHz	30	908.60	MHz	55	913.60	MHz	80	918.60	MHz	105	923.60	MHz
6	903.80	MHz	31	908.80	MHz	56	913.80	MHz	81	918.80	MHz	106	923.80	MHz
7	904.00	MHz	32	909.00	MHz	57	914.00	MHz	82	919.00	MHz	107	924.00	MHz
8	904.20	MHz	33	909.20	MHz	58	914.20	MHz	83	919.20	MHz	108	924.20	MHz
9	904.40	MHz	34	909.40	MHz	59	914.40	MHz	84	919.40	MHz	109	924.40	MHz
10	904.60	MHz	35	909.60	MHz	60	914.60	MHz	85	919.60	MHz	110	924.60	MHz
11	904.80	MHz	36	909.80	MHz	61	914.80	MHz	86	919.80	MHz	111	924.80	MHz
12	905.00	MHz	37	910.00	MHz	62	915.00	MHz	87	920.00	MHz	112	925.00	MHz
13	905.20	MHz	38	910.20	MHz	63	915.20	MHz	88	920.20	MHz	113	925.20	MHz
14	905.40	MHz	39	910.40	MHz	64	915.40	MHz	89	920.40	MHz	114	925.40	MHz
15	905.60	MHz	40	910.60	MHz	65	915.60	MHz	90	920.60	MHz	115	925.60	MHz
16	905.80	MHz	41	910.80	MHz	66	915.80	MHz	91	920.80	MHz	116	925.80	MHz
17	906.00	MHz	42	911.00	MHz	67	916.00	MHz	92	921.00	MHz	117	926.00	MHz
18	906.20	MHz	43	911.20	MHz	68	916.20	MHz	93	921.20	MHz	118	926.20	MHz
19	906.40	MHz	44	911.40	MHz	69	916.40	MHz	94	921.40	MHz	119	926.40	MHz
20	906.60	MHz	45	911.60	MHz	70	916.60	MHz	95	921.60	MHz	120	926.60	MHz
21	906.80	MHz	46	911.80	MHz	71	916.80	MHz	96	921.80	MHz	121	926.80	MHz
22	907.00	MHz	47	912.00	MHz	72	917.00	MHz	97	922.00	MHz	122	927.00	MHz
23	907.20	MHz	48	912.20	MHz	73	917.20	MHz	98	922.20	MHz	123	927.20	MHz
24	907.40	MHz	49	912.40	MHz	74	917.40	MHz	99	922.40	MHz	124	927.40	MHz

Table 1 Channel Frequency Table for PCB-915RM-SD

## 2.2 CONNECTOR PIN ASSIGNMENT

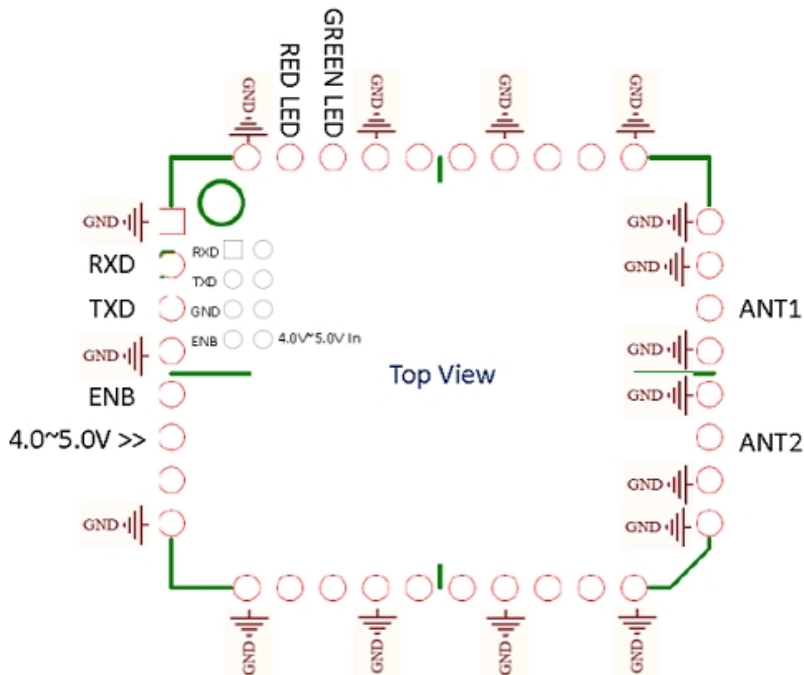

Note: ENB pulled high to enable module. Tied to power for *Always-On* applications.

## 2.3 FORM FACTOR

