

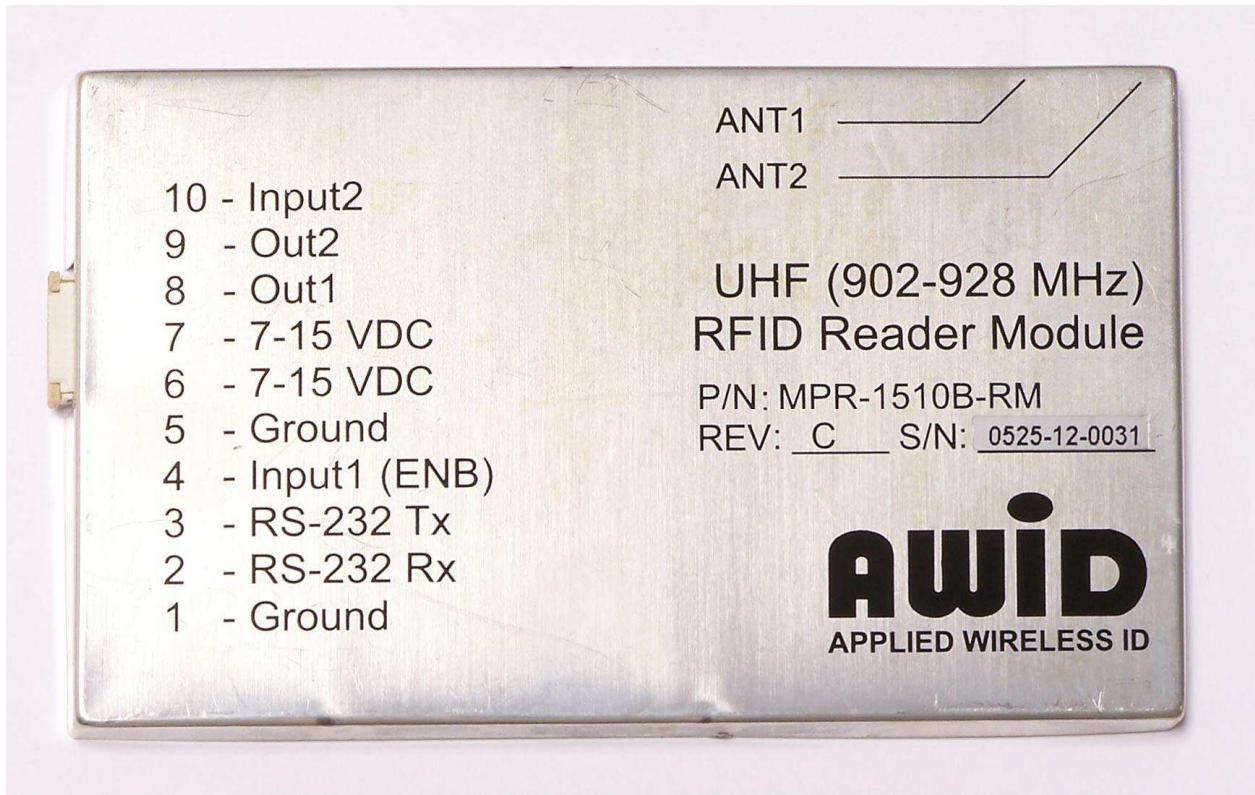

SENTINEL-SENSE MPR-1510B-RM

2.7c

OEM Installation Manual - 041312



COPYRIGHT ACKNOWLEDGEMENTS

The contents of this document are the property of Applied Wireless Identifications Group, Inc. (AWID) and are copyrighted. All rights reserved. Any reproduction, in whole or in part, is strictly prohibited. For additional copies of this document please contact:

AWID

18300 Sutter Blvd

Morgan Hill, CA 95037

<http://www.AWID.com>

The information contained herein has been carefully checked and is believed to be accurate, no responsibility is assumed for inaccuracies. AWID reserves the right to make changes without prior notice. This document is not covered by any warranty either expressed or implied. Any comments, corrections or additions to the contents of this document should be directed to AWID at the above address.

Copyright 2006 AWID, Printed in USA.

All other trademarks are the property of their respective owners.

SAFETY INFORMATION FOR RF EXPOSURE

IMPORTANT NOTE:

FCC Radiation Exposure Statement:

This equipment complies with FCC radiation exposure limits set forth for an uncontrolled environment. End users must follow the specific operating instructions for satisfying RF exposure compliance.

This device is intended only for OEM integrators under the following conditions:

1. The antenna must be installed such that 20cm is maintained between the antenna and users;

and
2. The transmitter module may not be co-located with any other transmitter or antenna.

IMPORTANT NOTE: In the event that these conditions can not be met (for example certain laptop configurations or co-location with another transmitter), then the FCC authorization is no longer considered valid and the FCC ID can not be used on the final product. In these circumstances, the OEM integrator will be responsible for re-evaluating the end product (including the transmitter) and obtaining a separate FCC authorization.

End Product Labeling

This transmitter module is authorized only for use in devices where the antenna may be installed such that 20 cm may be maintained between the antenna and users. The final end product must be labeled in visible area with the following:

“Contains TX FCC ID: OGSM27CA”

End Product Manual Information

The user manual for end users must include the following information in a prominent location:

“IMPORTANT NOTE:

To comply with FCC RF exposure compliance requirements, the antenna used for this transmitter must be installed to provide a separation distance of at least 20cm from all persons and must not be co-located or operating in conjunction with any other antenna or transmitter.”

U.S.A.

U.S.FEDERAL COMMUNICATIONS COMMISSION

RADIO FREQUENCY INTERFERENCE STATEMENT

INFORMATION TO THE USER

NOTE : This equipment has been tested and found to comply with the limits for a Class B digital device pursuant to Part 15 of the FCC Rules.

These limits are designed to provide reasonable protection against harmful Interference in a residential installation This equipment generates, uses, and can radiate radio frequency energy and, if Not installed and used in accordance with the instructions, may cause harmful Interference to radio communications. However, there is no guarantee that interference will not occur in a particular Installation. If this equipment does cause harmful interference to radio or television reception, which can be determined by turning the equipment off and on, the user is encouraged to try to correct the interference by one or more of the following measures:

- Reorient or relocate the receiving antenna.
- Increase the separation between the equipment and receiver.
- Connect the equipment into an outlet of a circuit different from that to which the receiver is connected.
- Consult the dealer or an experienced radio/TV technician for assistance.

Changes or modification not expressly approved by the party responsible for Compliance could void the user's authority to operate the equipment. Connecting of peripherals requires the use of grounded shielded signal cables.

FCC Compliance Information

This device complies with Part 15 of FCC Rules.

Operation is subject to the following two conditions:

- 1) This device may not cause harmful interference, and
- 2) This device must accept any interference received, including interference that may cause undesired operation.

This device has been designed to operate with the antennas listed below, and having a maximum gain of 6 dBi. Antennas not included in this list or having a gain greater than 6 dBi are strictly prohibited for use with this device.

| Mfg | Model | Type | Maximum Gain (dBi) |
|------------|--|-------------|---------------------------|
| AWID | MPR2010ANT | Patch | 5.59 |
| AWID | 915CPS-A (with 8ft cable AWID PN: RTC8) | Patch | 4.9 |
| Snyder | 1x4 Dipole | Dipole | 2.15 |

To reduce potential radio interference to other users, the antenna type and its gain should be so chosen that the equivalent isotropically radiated power (EIRP) is not more than that required for successful communication.

The OEM integrator will control¹ the appropriate power level based on input data as listed in table below.

| Pout (dBm) | Code | Pout (dBm) | Code |
|-------------------|-------------|-------------------|-------------|
| 28.0 | 0 | 22.0 | 228 |
| 27.5 | 100 | 21.5 | 233 |
| 27.0 | 125 | 21.0 | 237 |
| 26.5 | 146 | 20.5 | 240 |
| 25.5 | 176 | 20.0 | 243 |
| 25.0 | 188 | 19.5 | 246 |
| 24.5 | 198 | 19.0 | 248 |
| 24.0 | 206 | 18.5 | 251 |
| 23.5 | 212 | 18.0 | 253 |
| 23.0 | 218 | 17.5 | 254 |
| 22.5 | 223 | 17.0 | 255 |

¹ This refers to a special OEM capability to set the upper limit of the RF Power Level for the device and the operation is password protected.

Table of Contents

| | | |
|----------|---|-----------|
| 1 | INTRODUCTION..... | 7 |
| 1.1 | Special Features | 7 |
| 2 | SPECIFICATIONS..... | 8 |
| 2.1 | Channel Frequency Table | 8 |
| 2.2 | Connector Pin Assignment | 8 |
| 2.3 | Measuring Read Distance | 9 |
| 3 | INSTALLATION & OPERATION GUIDELINES | 10 |
| 3.1 | Site Survey | 10 |
| 3.2 | General Wiring Requirements | 10 |
| 3.3 | Wiring Diagrams..... | 10 |
| 4 | INSTALLATION PROCEDURE..... | 11 |
| 4.1 | Parts List | 11 |
| 4.2 | Preparation for Installation | 11 |
| 4.2.1 | <i>Bench Top Verification</i> | 11 |
| 5 | SOFTWARE PROGRAMMING AND SYSTEM OPERATION NOTES | 12 |
| 5.1 | System Operation..... | 12 |
| 5.1.1 | <i>Running a Custom Software Application or the AWID Demo Program</i> | 12 |
| 5.1.2 | <i>Operating Modes</i> | 12 |
| 5.2 | Users Note..... | 12 |
| 6 | MPR SERIAL COMMUNICATION PROTOCOL..... | 13 |

NOTE: READ AND USE THIS MANUAL.

NOTE: FAILURE TO FOLLOW THE INSTALLATION GUIDE MAY RESULT IN POOR PERFORMANCE OR EVEN CAUSE PERMANENT DAMAGE TO THE READER, THUS VOIDS THE PRODUCT WARRANTY.

1 INTRODUCTION

AWID's Sentinel-Sense MPR-1510-B-RM Rev. 2.7c (MPR-1510BR 2.7c or simply 2.7c) is a long-range (12 to 15 feet) Radio Frequency IDentification (RFID) Reader Module with RS-232 I/O interface that works with most leading passive UHF passive tags. This reader comes with a unique combination of long read range, small size, and low power consumption. The reader module has an internal power converter, allowing it to work with a wide range of supply inputs without affecting its performance. Its primary applications are asset management and tracking, and fleet management applications.

The MPR-1510BR 2.7c reader modules are delivered with firmware version 3.xxM.

In order to operate an MPR-1510BR 2.7c you will need the following:

- PC running Windows² 98 or higher, CD-ROM drive and one RS-232 serial port.
- Host software (AWID's demo software or your own custom software)

1.1 SPECIAL FEATURES

- Multi-Protocol: ISO-18000-6 Type B, EPC Class 1³, Gen 1 & 2, EPC V1.19 Rev.2, EM and EPC Class 0
- Thin passive tags with long-range performance
- RS-232 outputs

² Though an MPR-1510BR can also be controlled from a non-Windows programming platform, AWID demo and FW upgrade programs are applications to run in Windows.

³ Both 64- and 96-bit

2 SPECIFICATIONS

| | |
|-----------------------------|---|
| Input voltage | +7.0 VDC to +15 VDC |
| Input current | 1.0 A (7.0 V) to 0.40 A (15 V) typical |
| Protocol language | ISO Type B, EPC Class 1 Gen 1 & 2, EPC V1.19 Rev.2, EPC Class 0, EM |
| Read range | Depends on type & size of labels used |
| Output power | +30 dBm max |
| Transmit frequency | 905.11~917.17 MHz |
| Receiver frequency | 905.11~917.17 MHz (Amplitude Modulated) |
| Hopping channels | 50 Channels |
| Channel spacing | 250 kHz |
| Hopping sequence | Pseudo random |
| Operating temperature range | -30° C to +65° C (-22° F to 149° F) |
| Output data formats | RS-232 Version: |
| I/O Connector | DB-9 connector |
| Dimension | 3"x5"x0.25" |

2.1 CHANNEL FREQUENCY TABLE

Frequency range⁴: 905.11 ~ 917.17 MHz

Minimum Number of frequency channels: 50

| CH | 902~928 | MHz | CH | 902~928 | MHz | CH | 902~928 | MHz | CH | 902~928 | MHz | CH | 902~928 | MHz |
|----|---------|-----|----|---------|-----|----|---------|-----|----|---------|-----|----|---------|-----|
| 8 | 905.11 | MHz | 18 | 907.57 | MHz | 28 | 910.03 | MHz | 38 | 912.49 | MHz | 48 | 914.95 | MHz |
| 9 | 905.35 | MHz | 19 | 907.82 | MHz | 29 | 910.28 | MHz | 39 | 912.74 | MHz | 49 | 915.20 | MHz |
| 10 | 905.60 | MHz | 20 | 908.06 | MHz | 30 | 910.52 | MHz | 40 | 912.98 | MHz | 50 | 915.45 | MHz |
| 11 | 905.85 | MHz | 21 | 908.31 | MHz | 31 | 910.77 | MHz | 41 | 913.23 | MHz | 51 | 915.69 | MHz |
| 12 | 906.09 | MHz | 22 | 908.55 | MHz | 32 | 911.02 | MHz | 42 | 913.48 | MHz | 52 | 915.94 | MHz |
| 13 | 906.34 | MHz | 23 | 908.80 | MHz | 33 | 911.26 | MHz | 43 | 913.72 | MHz | 53 | 916.18 | MHz |
| 14 | 906.58 | MHz | 24 | 909.05 | MHz | 34 | 911.51 | MHz | 44 | 913.97 | MHz | 54 | 916.43 | MHz |
| 15 | 906.83 | MHz | 25 | 909.29 | MHz | 35 | 911.75 | MHz | 45 | 914.22 | MHz | 55 | 916.68 | MHz |
| 16 | 907.08 | MHz | 26 | 909.54 | MHz | 36 | 912.00 | MHz | 46 | 914.46 | MHz | 56 | 916.92 | MHz |
| 17 | 907.32 | MHz | 27 | 909.78 | MHz | 37 | 912.25 | MHz | 47 | 914.71 | MHz | 57 | 917.17 | MHz |

2.2 CONNECTOR PIN ASSIGNMENT

| <u>Pin</u> | <u>Function</u> | <u>Pin</u> | <u>Function</u> |
|------------|-----------------|------------|-----------------|
| 1 | Ground | 6 | +7V/+15V |
| 2 | RS232 Tx | 7 | +7V/+15V |
| 3 | RS232 Rx | 8 | Data 0 |
| 4 | Enable RFID | 9 | Data 1 |
| 5 | Ground | 10 | Ext Data in |

⁴ Notice that capability to change frequency settings is not available to end users.

2.3 MEASURING READ DISTANCE

Make sure you know the tag types. For certain readers and tags, user must also be mindful of the tag's orientation and the reader's antenna orientation, what mounting surface the tags are designed for and how the tags are supposed to be mounted. Any departure from its intended purpose will drastically affect the reader's ability to energize the tag and its read range.

When measuring the reader's read range, make sure that the tag is properly oriented to the reader antenna, and for optimum performance, be sure the operator's finger is not within three (3) inches of the tag's antenna surface.

3 INSTALLATION & OPERATION GUIDELINES

For ease of explanation, MPR reader in this section refers to an RFID device that consists of 2.7c and a high performance circular polarized antenna inside a splash proof, UV stabilized housing case.

3.1 SITE SURVEY

3.2 GENERAL WIRING REQUIREMENTS

All the MPR reader wiring should be continuously shielded. AWID recommends using #24 AWG up to #22 AWG, longer distances and higher current consumption on the power supply line will require larger gauge wires.

TABLE 3.4-1: Data Line's Wiring Requirement

| WIRE SIZE | #22 AWG (0.6 mm Dia.) | #24 AWG (0.5 mm Dia.) |
|-----------|-----------------------|-----------------------|
| RS-232 | 50 ft (15 meters) | 50 ft (15 meters) |

3.3 WIRING DIAGRAMS

See section 2.2 for pin assignment for the RS-232 connector of a 2.7c.

The MPR RS-232 interface is a short distance serial interface, a full command set for the standard serial interface is not necessary, therefore only transmit, receive and ground wires are used. Sense input is an enable input, which is traditionally used to activate the RF energy of the reader and to start the read functions.

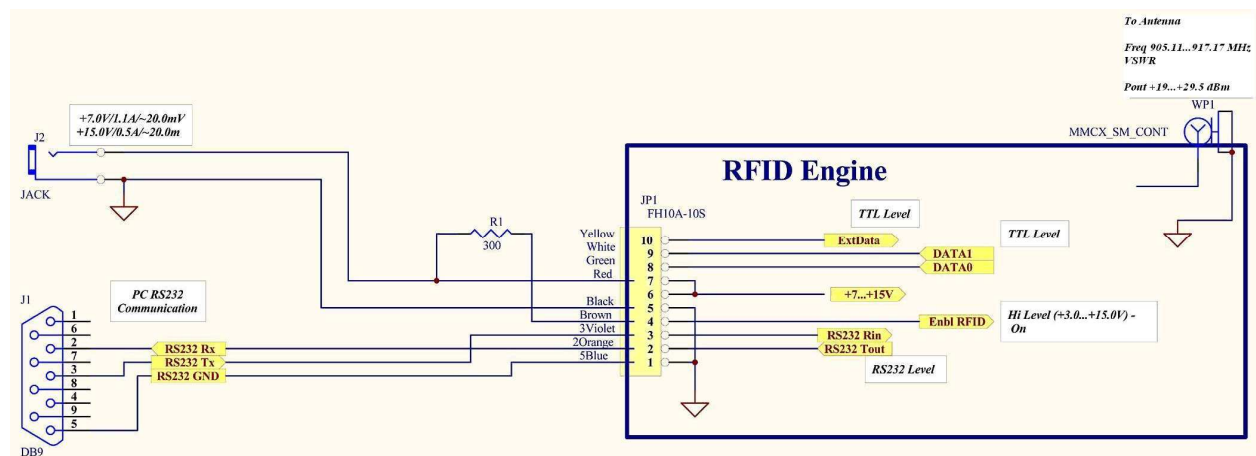

4 INSTALLATION PROCEDURE

This section provides installation and operation information for MPR readers.

4.1 PARTS LIST

Verify that all items listed below are present before starting the installation.

- Sentinel-Sense – MPR-1510BR 2.7c Qty=1
- Documentation and Demo Program CD Qty=1

4.2 PREPARATION FOR INSTALLATION

Familiarize yourself with the connectors and pin out assignment of each I/O connectors.

4.2.1 Bench Top Verification

It is always a good idea to verify system operation before committing to a full-scale installation. The following are the necessary steps to test the reader's operation in a static environment.

- Connect MPR reader module to the RS-232 port of a PC
- Connect the power jack from the wall plug power supply to reader module
- Power up PC
- Install demo software on PC
- Activate demo software and verify performance of the reader.
- Select a COM port on top page then click "Connect". Follow with some commands.

5 SOFTWARE PROGRAMMING AND SYSTEM OPERATION NOTES

5.1 SYSTEM OPERATION

5.1.1 Running a Custom Software Application or the AWID Demo Program

If AWID Demo Program is not used, it is expected user will launch a Custom Software Application developed using the MPR Serial Communication Protocol to send commands as specified to the MPR reader.

5.1.2 Operating Modes

Typical operating modes for MPR readers can be grouped into the following modes:

Search Mode

This mode is used when operator or user is not certain what family of tags is placed on the items to be tracked. Since most tags are deterministic in nature, MPR reader must cycle through each and every protocol, issue a protocol specific inquiry, to hail and to wait for a response from tags of that specific protocol. If there are many different protocols the reader response will appear sluggish.

Mixed Mode

This mode assumes the user is aware of the types of protocol in use, and furthermore, the user made a determined effort to operate the reader in a mixed protocol mode. In this mode, the user can decide how many and which specific protocols to be selected. Once Mix Protocol Mode is selected, the reader will routinely cycle through each protocol, dwell long enough for the reader to wait for a response and then move on to the next protocol. It should be noted that in a mixed protocol mode, the tag must have sufficient time to respond to the reader, and therefore, it can only be used on a conveyor belt arrangement, with specific speed restrictions.

Single Protocol Mode

Single protocol is the normal mode of operation, where the protocol type is known and many tags are expected to pass through the readers.

5.2 USERS NOTE

For System Integrators and/or Software Developers

System Integrators and/or Software developers should get familiar with the MPR Serial Communication Protocol specifications for developing applications that control AWID's Serial Communication MPR readers.

For Custom System Users

For custom system user, please refer to your host software user guide for information regarding system and software operations

For Demo Software Users

If you are using the AWID RFID demonstration software application which is .NET based with easy-to-follow GUI operations, simply select the COM port for which the MPR reader is configured then click "Connect" should get you started.

6 MPR SERIAL COMMUNICATION PROTOCOL

See MPR Serial Communication Protocol Manual - 041304