

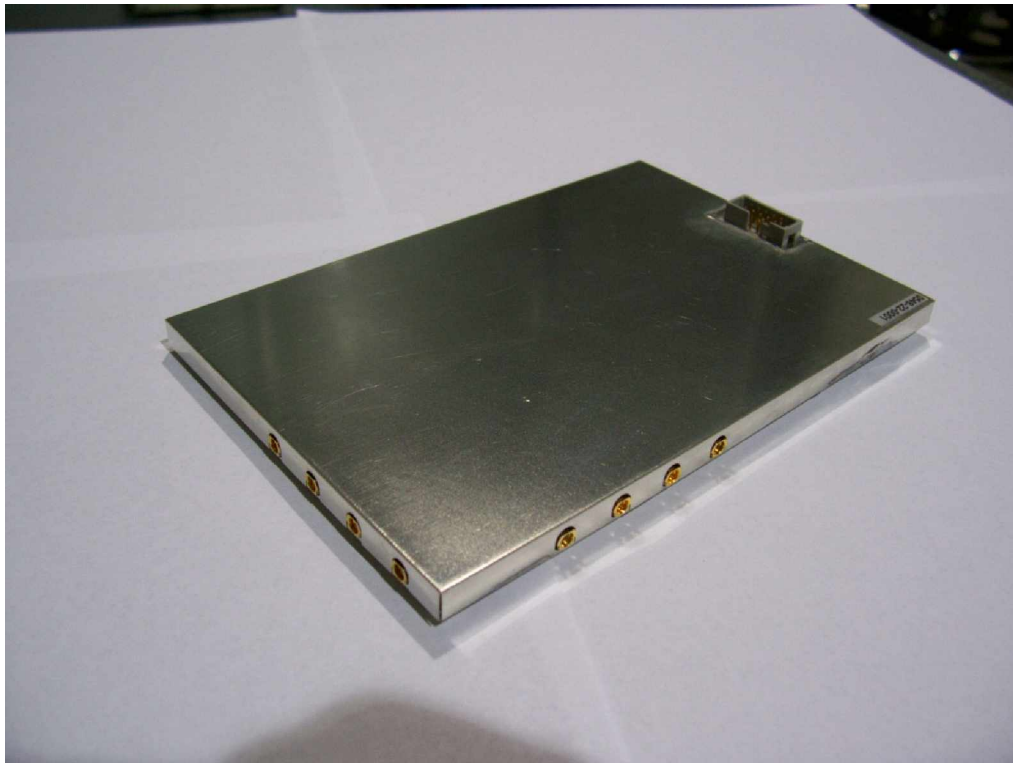

# SENTINEL-SENSE MPR-1510

**3.2x**

## **Installation & Operation Manual**



## **COPYRIGHT ACKNOWLEDGEMENTS**

The contents of this document are the property of Applied Wireless Identifications Group, Inc. (AWID) and are copyrighted. All rights reserved. Any reproduction, in whole or in part, is strictly prohibited. For additional copies of this document please contact:

AWID

18300 Sutter Blvd

Morgan Hill, CA 95037

[www.sales-ast@AWID.com](mailto:www.sales-ast@AWID.com)

The information contained herein has been carefully checked and is believed to be accurate, no responsibility is assumed for inaccuracies. AWID reserves the right to make changes without prior notice. This document is not covered by any warranty either expressed or implied. Any comments, corrections or additions to the contents of this document should be directed to AWID at the above address.

Copyright 2006 AWID, Printed in USA.

All other trademarks are the property of their respective owners.

## **FCC COMPLIANCE**

This equipment has been tested and found to be in compliance with the limits for FCC Part 15, Class A digital device. These limits are designed to provide reasonable protection against harmful interference when the equipment is operated in a commercial environment. This equipment generates, uses and can radiate radio frequency energy and, if not installed and used in accordance with instruction manual, may cause harmful interference with radio communications. Operation of this equipment in a residential area is likely to cause harmful interference in which case the user will be required to correct the interference at his own expense.

The users are prohibited from making any change or modification to this product, any modification to this product shall voids the user's authority to operate under FCC Part 15 Subpart A Section 15.21 regulations.

This device complies with Part 15 of the FCC Rules. Operation is subject to the following two conditions: (1) This device may not cause harmful interference and, (2) this device must accept any interference received, including interference that may cause undesired operation.

The antenna(s) used for this transmitter must not be co-located or operating in conjunction with any other antenna or transmitter.

## **INDUSTRY CANADA COMPLIANCE**

Operation is subject to the following two conditions: (1) this device may not cause interference and (2) this device must accept any interference, including interference that may cause undesired operation of the device.



**AWID PROPRIETARY**

This device has been designed to operate with the antennas listed below, and having a maximum gain of 10 dBi. Antennas not included in this list or having a gain greater than 10 dB are strictly prohibited for use with this device. The required antenna impedance is 50 ohms.

- 1) Mti, model MT-263003/N; 10 dBi Linear polarization directional antenna (Patch)
- 2) Snyder Antenna Systems, part # ANT-UHF-1x4-SMA; 2 dBi Dipole antenna (Dipole)
- 3) AWID, model HYBRID 915MHz; 6 dBi Circular polarized antenna (Patch)
- 4) Mti, model MT-262002/N/A; 8 dBi Linear polarization directional antenna (Patch)

To reduce potential radio interference to other users, the antenna type and its gain should be so chosen that the equivalent isotropically radiated power (EIRP) is not more than that required for successful communication.

**CAUTION:**

**Reader should be positioned so that personnel in the area for prolonged periods may safely remain at least 23 cm (9 in) in an uncontrolled environment from the reader's surface. Observe FCC OET Bulletin 56 "Hazards of radio frequency and electromagnetic fields" and Bulletin 65 "Human exposure to radio frequency electromagnetic fields."**

## Table of Contents

<b>1</b>	<b>INTRODUCTION.....</b>	<b>5</b>
1.1	Special Features .....	5
<b>2</b>	<b>SPECIFICATIONS.....</b>	<b>6</b>
2.1	Channel Frequency Table.....	6
2.2	Connector Pin Assignment.....	6
2.3	Measuring Read Distance.....	6
<b>3</b>	<b>INSTALLATION &amp; OPERATION GUIDELINES .....</b>	<b>8</b>
3.1	Site Survey.....	8
3.2	Preferred Reader Installation Practices .....	8
3.3	Mounting Preference.....	8
3.4	General Wiring Requirements.....	8
3.5	Grounding .....	9
3.6	Wiring Diagrams .....	9
<b>4</b>	<b>INSTALLATION PROCEDURE .....</b>	<b>10</b>
4.1	Parts List.....	10
4.2	Preparation for Installation .....	10
4.2.1	Bench Top Verification.....	10
4.2.2	Antenna Pattern.....	10
<b>5</b>	<b>SOFTWARE PROGRAMMING AND SYSTEM OPERATION NOTES.....</b>	<b>12</b>
5.1	System Operation .....	12
5.1.1	Running a Custom Software Application or the AWID Demo Program.....	12
5.1.2	Operating Modes .....	12
5.2	Users Note.....	12
<b>6</b>	<b>MPR 3014 PROTOCOL.....</b>	<b>13</b>

**NOTE: READ AND USE THIS MANUAL.**

**FAILURE TO FOLLOW THE INSTALLATION GUIDE MAY RESULT IN POOR PERFORMANCE OR EVEN CAUSE PERMANENT DAMAGE TO THE READER, THUS VOIDS THE PRODUCT WARRANTY.**

## 1 INTRODUCTION

AWID's Sentinel-Sense MPR-1510 3.2x is a long-range (12 to 15 feet) Radio Frequency IDentification (RFID) reader module with RS-232 I/O interface that works with most leading passive UHF passive tags. This reader comes with a unique combination of long read range, small size, and low power consumption. The reader module has an internal power converter, allowing it to work with a wide range of supply inputs without affecting its performance. Its primary applications are asset management and tracking, and fleet management applications.

The MPR-1510 3.2x reader modules are delivered with the following:

- MPR-1510-RM 3.2x REV: E with firmware version 5.xxN

In order to operate an MPR-1510 3.2x you will need the following:

- Standard antenna(s) each with 10dBi gain or less
- PC running Windows<sup>1</sup> 98 or higher, CD-ROM drive and one RS-232 serial port.
- Host software (AWID's demo software or your own custom software)
- RFID Tags (EPC Class 0, 1, ISO Type B, etc)

### 1.1 SPECIAL FEATURES

- Multi-Protocol: ISO-18000-6 Type A/B, EPC Class 1<sup>2</sup>, Gen 1 & 2, EPC Class0<sup>3</sup>, EPC V1.19 Rev.2
- Thin passive tags with long-range performance
- RS-232 outputs

<sup>1</sup> Though MPR-1510 3.2x can also be controlled from a non-Windows programming platform, AWID demo and FW upgrade programs are applications to run in Windows.

<sup>2</sup> Both 64- and 96-bit

<sup>3</sup> Both 64- and 96-bit

## 2 SPECIFICATIONS

Input voltage	+7.0 VDC to +15 VDC
Input current	1.0 A (7.0 V) to 0.40 A (15 V) typical
Protocol language	ISO Type B, EPC Class 1 Gen 1 & 2, EPC Class 0, EPC V1.19 Rev.2
Read range	Depends on type & size of labels used
Output power	0.383 Watt into 10 dBi antenna
Transmit frequency	902-928 MHz
Receiver frequency	902-928 MHz (Amplitude Modulated)
Hopping channels	50 Channels
Channel spacing	500 kHz
Hopping sequence	Pseudo random
Operating temperature range	-30° C to +65° C (-22° F to 149° F)
Output data formats	RS-232 Version:
I/O Connector	DB-9 connector
Dimension	4"x6"x0.25"

### 2.1 CHANNEL FREQUENCY TABLE

Frequency range: 902 ~ 928 MHz

Minimum Number of frequency channels: 50

CH	902~928	MHz	CH	902~928	MHz	CH	902~928	MHz	CH	902~928	MHz	CH	902~928	MHz
0	902.75	MHz	10	907.75	MHz	20	912.75	MHz	30	917.75	MHz	40	922.75	MHz
1	903.25	MHz	11	908.25	MHz	21	913.25	MHz	31	918.25	MHz	41	923.25	MHz
2	903.75	MHz	12	908.75	MHz	22	913.75	MHz	32	918.75	MHz	42	923.75	MHz
3	904.25	MHz	13	909.25	MHz	23	914.25	MHz	33	919.25	MHz	43	924.25	MHz
4	904.75	MHz	14	909.75	MHz	24	914.75	MHz	34	919.75	MHz	44	924.75	MHz
5	905.25	MHz	15	910.25	MHz	25	915.25	MHz	35	920.25	MHz	45	925.25	MHz
6	905.75	MHz	16	910.75	MHz	26	915.75	MHz	36	920.75	MHz	46	925.75	MHz
7	906.25	MHz	17	911.25	MHz	27	916.25	MHz	37	921.25	MHz	47	926.25	MHz
8	906.75	MHz	18	911.75	MHz	28	916.75	MHz	38	921.75	MHz	48	926.75	MHz
9	907.25	MHz	19	912.25	MHz	29	917.25	MHz	39	922.25	MHz	49	927.25	MHz

### 2.2 CONNECTOR PIN ASSIGNMENT

<u>Pin#</u>	<u>Function</u>	<u>Pin#</u>	<u>Function</u>
1	Data 1	6	Enable RFID
2	Ext Data in	7	Ground
3	RS232 Tx	8	+7V/+15V
4	Data 0	9	Ground
5	RS232 Rx	10	+7V/+15V

### 2.3 MEASURING READ DISTANCE

Make sure you know the tag types. For certain readers and tags, user must also be mindful of the tag's orientation and the reader's antenna orientation, what mounting surface the tags are designed for and how the tags are supposed to be mounted. Any departure from its intended purpose will drastically affect the reader's ability to energize the tag and its read range.

When measuring the reader's read range, make sure that the tag is properly oriented to the reader antenna, and for optimum performance, be sure the operator's finger is not within three (3) inches of the tag's antenna surface.

### 3 INSTALLATION & OPERATION GUIDELINES

For ease of explanation, MPR reader in this section refers to an MPR-3014 reader model, i.e., a unit that consists of MPR-1510 (3.2e) inside a splash proof, UV stabilized housing case and high performance circular polarized antenna(s).

#### 3.1 SITE SURVEY

Always conduct a site survey before starting installation. Avoid any possible sources of interference. For best result, use a spectrum analyzer with a wideband antenna and set the spectrum analyzer in Max Hold mode to gain measurement of the maximum signal strength on the airwave. If the MPR reader is not installed properly, the performance will be degraded. Listed below are steps that should be followed during installation:

- Do not install the MPR reader in an area where sources of broadband noise may exist. Avoid mounting the reader facing a cellular phone tower or in close proximity to the base station of a 900 MHz wireless telephone.
- Keep all of the MPR reader wiring a safe distance from all other wiring, including, but not limited to, AC power, computer data wiring, and telephone wiring, and wiring to electrical locking devices.
- Avoid operating the MPR reader in close proximity to other 900 MHz wireless local area networking (WLAN) equipment. It should be noted that MPR-2010s (, etc. are known to work in electromagnetic crowded areas, such as trade shows.

#### 3.2 PREFERRED READER INSTALLATION PRACTICES

- Avoid mounting the MPR reader under direct sunlight. Exposure to direct sunlight may cause the reader to operate at a temperature above the 65 degrees Celsius upper limit.
- Make sure that the supply voltage of the MPR reader is within specification
- Use cables with over-all shield (screen)
- For best results, avoid bundling data cable with AC power and computer cables
- Use the largest wire gauge where feasible
- Use dedicated power supply, where necessary
- Use Single Point Grounding, and avoid ground loops

#### 3.3 MOUNTING PREFERENCE

An MPR-3014 reader uses uni-directional antennas each with an antenna beam width of about 60-70 degrees. The radiation pattern is an oval-shaped beam, which should be aimed toward where the transponders will pass.

#### 3.4 GENERAL WIRING REQUIREMENTS

All the MPR reader wiring should be continuously shielded. AWID recommends using #24 AWG up to #22 AWG, longer distances and higher current consumption on the



power supply line will require larger gauge wires. PG I/O output are standard access industry Wiegand drivers, which is capable of 500 feet driving distance.

TABLE 3.4-1: Data Line's Wiring Requirement

WIRE SIZE	#22 AWG (0.6 mm Dia.)	#24 AWG (0.5 mm Dia.)
RS-232	50 ft (15 meters)	50 ft (15 meters)

### 3.5 GROUNDING

Grounding is critical for proper operation of MPR-1510. When installing the readers, it is crucial to assure that the earth ground is the best ground available. If you elect to use the 120 VAC power ground, conduct a test by measuring its resistance relative to a known good ground, such as a cold water pipe or structural steel that is in direct contact with the ground. The resistance should be less than 50 ohms.

### 3.6 WIRING DIAGRAMS

See section 2.1 for pin assignment for the RS-232 connector of an MPR-1510 3.2x.

The MPR RS-232 interface is a short distance serial interface, a full command set for the standard serial interface is not necessary, therefore only transmit, receive and ground wires are used. Sense input is an enable input, which is traditionally used to activate the RF energy of the reader and to start the read functions.

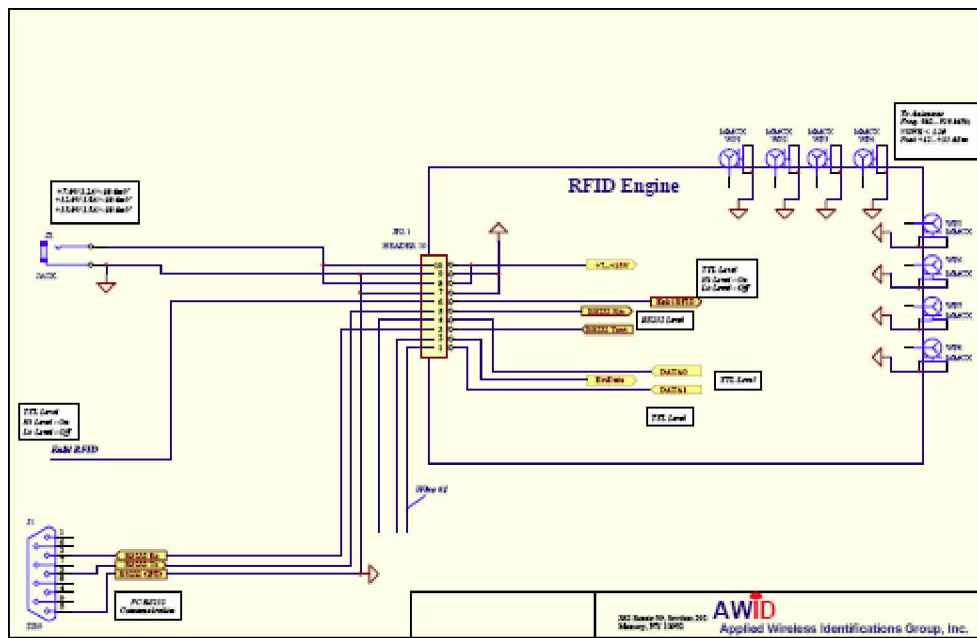

## 4 Installation Procedure

This section provides installation and operation information for MPR readers.

### 4.1 PARTS LIST

Verify that all items listed below are present before starting the installation.

- Sentinel-Sense MPR-1510 reader module 3.2x Qty=1
- Documentation and Demo Program CD Qty=1

### 4.2 PREPARATION FOR INSTALLATION

Familiarize yourself with the connectors and pin out assignment of each I/O connectors.

#### 4.2.1 Bench Top Verification

It is always a good idea to verify system operation before committing to a full-scale installation. The following are the necessary steps to test the reader's operation in a static environment.

- Connect MPR reader module to the RS-232 port of a PC
- Connect power (via the power jack from a wall plug power supply) to the MPR reader module
- Connect Antenna(s)
- Power up PC
- Install demo software on PC
- Activate demo software and verify performance of the reader.
- Select COM port 1 on top page then click "Connect". Follow with some commands.
- Place the RFID tags at the exact same locations as the final configuration
- Measure tag's read distance and confirm that read distance is correct.

#### 4.2.2 Antenna Pattern

MPR-1510 performs best with a circular polarized antenna to ensure reading tag with random orientation. Most circular polarized antenna has a horizontal to vertical differential of up to 3 dB, this will cause the antenna pattern to deviate from a true circle. AWID's antenna used with MPR-3014 readers has a horizontal to vertical differential of typically less than 0.5 dB, making its pattern as near to a circle as possible.

- Antenna pattern measurements represent both horizontal and vertical polarized planes of the read area transmitted by the reader.
- In the drawing below, R = approximately 12 feet to 15 feet with Alien free space tags.
- Antenna pattern can be affected by RFI and other environmental conditions.

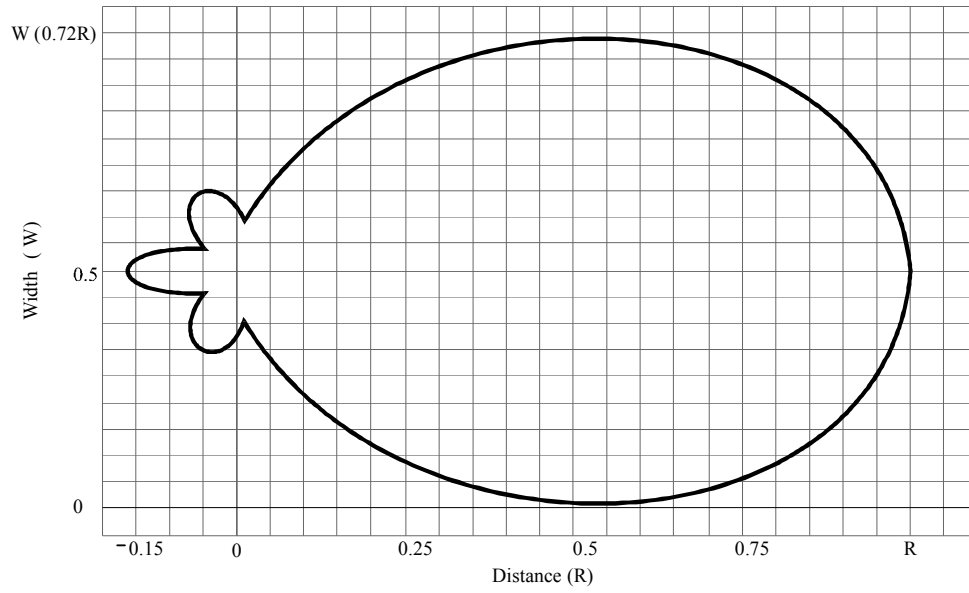

**Figure 3 Antenna Pattern**

## **5 SOFTWARE PROGRAMMING AND SYSTEM OPERATION NOTES**

### **5.1 SYSTEM OPERATION**

#### **5.1.1 Running a Custom Software Application or the AWID Demo Program**

If AWID Demo Program is not used, it is expected user will launch a Custom Software Application developed using the MPR 3014 Protocol for issuing commands as specified to the reader.

#### **5.1.2 Operating Modes**

Typical operating modes for MPR readers can be grouped into the following modes:

##### **Search Mode**

This mode is used when operator or user is not certain what family of tags are placed on the items to be tracked. Since most tags are deterministic in nature, MPR reader must cycle through each and every protocol, issue a protocol specific inquiry, to hail and to wait for a response from tags of that specific protocol. Therefore, if there are many different protocols, for an untrained observer, the reader response will appear sluggish.

##### **Mixed Mode**

This mode assumes the user is aware of the types of protocol in use, and furthermore, the user made a determined effort to operate the reader in a mixed protocol mode. In this mode, the user can decide how many and which specific protocols to be selected. Once Mix Protocol Mode is selected, the reader will routinely cycle through each protocol, dwell long enough for the reader to wait for a response and then move on to the next protocol. It should be noted that in a mixed protocol mode, the tag must have sufficient time to respond to the reader, and therefore, it can only be used on a conveyor belt arrangement, with specific speed restrictions.

##### **Single Protocol Mode**

Single protocol is the normal mode of operation, where the protocol type is known and many tags are expected to pass through the readers.

### **5.2 USERS NOTE**

#### **For System Integrators and/or Software Developers**

System Integrators and/or Software developers should get familiar with the MPR 3014 Protocol specifications for developing applications that control MPR-1510 3.2x modules.

#### **For Custom System Users**

For custom system user, please refer to your host software user guide for information regarding system and software operations

#### **For Demo Software Users**

If you are using the AWID RFID demonstration software application which is .NET based with easy-to-follow GUI operations, simply select the COM port for which the MPR reader module is configured then click "Connect" should get you started.

## **6 MPR 3014 PROTOCOL**

See MPR 3014 Protocol Manual - 041310