

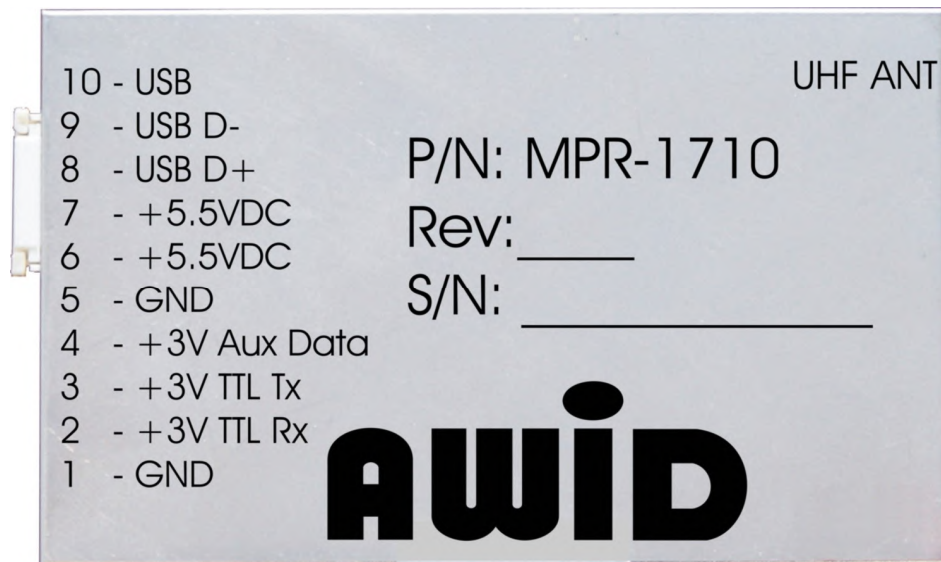

SENTINEL-SENSE MPR-1710

Installation & Operation Manual-041361



COPYRIGHT ACKNOWLEDGEMENTS

The contents of this document are the property of Applied Wireless Identifications Group, Inc. (AWID) and are copyrighted. All rights reserved. Any reproduction, in whole or in part, is strictly prohibited. For additional copies of this document please contact:

AWID

18300 Sutter Blvd

Morgan Hill, CA 95037

<http://www.AWID.com>

The information contained herein has been carefully checked and is believed to be accurate, no responsibility is assumed for inaccuracies. AWID reserves the right to make changes without prior notice. This document is not covered by any warranty either expressed or implied. Any comments, corrections or additions to the contents of this document should be directed to AWID at the above address.

Copyright 2006 AWID, Printed in USA.

All other trademarks are the property of their respective owners.

CAUTION:

Reader should be positioned so that personnel in the area for prolonged periods may safely remain at least 20 cm in an uncontrolled environment from the reader's surface. Observe FCC OET Bulletin 56 "Hazards of radio frequency and electromagnetic fields" and Bulletin 65 "Human exposure to radio frequency electromagnetic fields."

Table of Contents

REVISION HISTORY	4
1 INTRODUCTION.....	5
1.1 Special Features	5
2 SPECIFICATIONS	6
2.1 Channel Frequency Table.....	6
2.2 Connector Pin Assignment.....	6
2.3 Measuring Read Distance.....	7
3 INSTALLATION & OPERATION GUIDELINES	8
3.1 General Wiring Requirements.....	8
3.2 Wiring Diagrams	8
4 INSTALLATION PROCEDURE	9
4.1 Parts List.....	9
4.2 Preparation for Installation	9
4.2.1 Bench Top Verification.....	9
5 SOFTWARE PROGRAMMING AND SYSTEM OPERATION NOTES.....	10
5.1 System Operation	10
5.1.1 Running a Custom Software Application or the AWID Demo Program.....	10
5.1.2 Operating Modes	10
5.2 Users Note	10
6 MPR SERIAL COMMUNICATION PROTOCOL.....	11

NOTE: READ AND USE THIS MANUAL.

NOTE: FAILURE TO FOLLOW THE INSTALLATION GUIDE MAY RESULT IN POOR PERFORMANCE OR EVEN CAUSE PERMANENT DAMAGE TO THE READER, THUS VOIDS THE PRODUCT WARRANTY.

REVISION HISTORY

Version No.	Revised By	Date	Sections Affected	Remarks
0.1	E. Wei	3/2008	All	Initial version

1 INTRODUCTION

AWID's Sentinel-Sense MPR-1710 is a Radio Frequency IDentification (RFID) reader module with RS-232 and USB I/O interface that works with most leading passive UHF passive tags. The reader module comes with a unique combination of long read range, small size (credit card) and low power consumption. Its primary applications are access control, asset management and tracking, and fleet management applications.

The MPR-1710 reader modules are delivered with firmware version US0-211h1-xx.yy.00.

In order to operate an MPR-1710 you will need the following:

- PC running Windows¹ 2000 or higher, CD-ROM drive, USB and/or RS-232 serial port.
- Host software (AWID's demo software or your own custom software)

1.1 SPECIAL FEATURES

- UHF Multi-Protocol: ISO-18000-6 Type B/C, EPC Class 1 Gen 2
- Thin passive tags with long-range performance
- RS-232 and USB outputs

¹ Though MPR-1710 can also be controlled from a non-Windows programming platform, AWID demo and FW upgrade programs are applications to run in Windows.

2 SPECIFICATIONS

Input voltage	+5.225 VDC to +5.775 VDC
Input current	1.5 A (5.5 V) typical
Protocol language	ISO-18000-6 Type B/C, EPC Class 1 Gen 2
Read range	Depends on type & size of labels used
Output power	+24 dBm max
Transmit frequency	902.75-927.25 MHz
Receiver frequency	902.75-927.25 MHz (Amplitude Modulated)
Hopping channels	50 Channels
Channel spacing	500 kHz
Hopping sequence	Pseudo random
Operating temperature range	-30° C to +65° C (-22° F to 149° F)
Output data formats	3V TTL Serial & USB
I/O Connector	10-pin ZIF
Dimension	2"x3.25"x0.25

2.1 CHANNEL FREQUENCY TABLE

Frequency range: 902.75 ~ 927.25 MHz

Minimum number of frequency channels: 50

CH	902~928	MHz	CH	902~928	MHz	CH	902~928	MHz	CH	902~928	MHz	CH	902~928	MHz
0	902.75	MHz	10	907.75	MHz	20	912.75	MHz	30	917.75	MHz	40	922.75	MHz
1	903.25	MHz	11	908.25	MHz	21	913.25	MHz	31	918.25	MHz	41	923.25	MHz
2	903.75	MHz	12	908.75	MHz	22	913.75	MHz	32	918.75	MHz	42	923.75	MHz
3	904.25	MHz	13	909.25	MHz	23	914.25	MHz	33	919.25	MHz	43	924.25	MHz
4	904.75	MHz	14	909.75	MHz	24	914.75	MHz	34	919.75	MHz	44	924.75	MHz
5	905.25	MHz	15	910.25	MHz	25	915.25	MHz	35	920.25	MHz	45	925.25	MHz
6	905.75	MHz	16	910.75	MHz	26	915.75	MHz	36	920.75	MHz	46	925.75	MHz
7	906.25	MHz	17	911.25	MHz	27	916.25	MHz	37	921.25	MHz	47	926.25	MHz
8	906.75	MHz	18	911.75	MHz	28	916.75	MHz	38	921.75	MHz	48	926.75	MHz
9	907.25	MHz	19	912.25	MHz	29	917.25	MHz	39	922.25	MHz	49	927.25	MHz

Table 1 Channel Frequency Table for MPR-1710

2.2 CONNECTOR PIN ASSIGNMENT

<u>Pin</u>	<u>Function</u>	<u>Pin</u>	<u>Function</u>
1	USB	6	GND
2	USB D-	7	+3V Aux Data
3	USB D+	8	+3V TTL Rx
4	+5.5 V	9	+3V TTL Tx
5	+5.5 V	10	GND

2.3 MEASURING READ DISTANCE

Make sure you know the tag types. For certain readers and tags, user must also be mindful of the tag's orientation and the reader's antenna orientation, what mounting surface the tags are designed for and how the tags are supposed to be mounted. Any departure from its intended purpose will drastically affect the reader's ability to energize the tag and its read range.

When measuring the reader's read range, make sure that the tag is properly oriented to the reader antenna, and for optimum performance, be sure the operator's finger is not within three (3) inches of the tag's antenna surface.

3 INSTALLATION & OPERATION GUIDELINES

For ease of explanation, MPR reader in this section refers to an RFID device that consists of MPR-1710 and a high performance circular polarized antenna inside a splash proof, UV stabilized housing case. The module should be installed on a heat sink. Example of a heat sink could be an aluminum plate of size 8"x8"x0.1" exposed to convection air flow. The screws at the bottom of module shall be used for mounting the module on the heat sink.

3.1 GENERAL WIRING REQUIREMENTS

All the MPR reader wiring should be continuously shielded. AWID recommends using #24 AWG up to #22 AWG, longer distances and higher current consumption on the power supply line will require larger gauge wires.

TABLE 3.4-1: Data Line's Wiring Requirement

WIRE SIZE	#22 AWG (0.6 mm Dia.)	#24 AWG (0.5 mm Dia.)
RS-232	50 ft (15 meters)	50 ft (15 meters)

3.2 WIRING DIAGRAMS

See section 2.2 for pin assignment for the RS-232 connector of MPR-1710.

The MPR RS-232 interface is a short distance serial interface, a full command set for the standard serial interface is not necessary, therefore only transmit, receive and ground wires are used. Sense input is an enable input, which is traditionally used to activate the RF energy of the reader and to start the read functions.

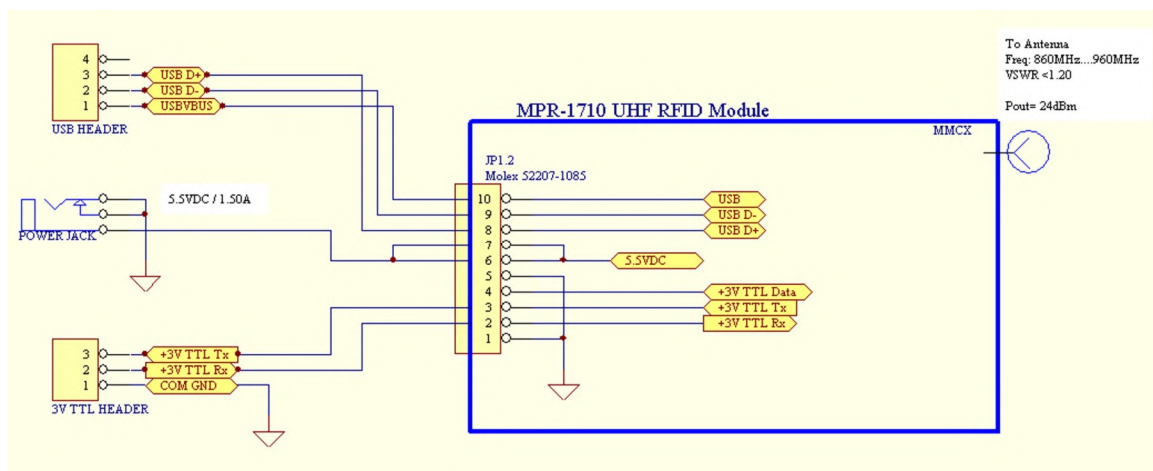

4 INSTALLATION PROCEDURE

This section provides installation and operation information for MPR-1710 reader modules.

4.1 PARTS LIST

Verify that all items listed below are present before starting the installation.

- Sentinel-Sense MPR-1710 Qty=1
- Documentation and command demo program CD Qty=1

4.2 PREPARATION FOR INSTALLATION

Familiarize yourself with the connectors and pin out assignment of each I/O connectors.

4.2.1 Bench Top Verification

It is always a good idea to verify system operation before committing to a full-scale installation. The following are the necessary steps to test the reader's operation in a static environment.

- Connect MPR-1710 to the RS-232 or USB port of a PC
- Connect the power jack from the wall plug power supply to reader module
- Power up PC
- Install demo software on PC
- Activate demo software and verify performance of the reader.
- Select a COM port in program window then click "Connect". Follow with some commands.

5 SOFTWARE PROGRAMMING AND SYSTEM OPERATION NOTES

5.1 SYSTEM OPERATION

5.1.1 Running a Custom Software Application or the AWID Demo Program

If AWID Demo Program is not used, it is expected user will launch a Custom Software Application developed using the *MPR-1710 Protocol* to issue commands to the MPR reader/module as specified.

5.1.2 Operating Modes

Typical operating modes for MPR readers can be grouped into the following modes:

Search Mode

This mode is used when operator or user is not certain what family of tags is placed on the items to be tracked. Since most tags are deterministic in nature, MPR reader must cycle through each and every protocol, issue a protocol specific inquiry, to hail and to wait for a response from tags of that specific protocol. Therefore, if there are many different protocols, for an untrained observer, the reader response will appear sluggish.

Mixed Mode

This mode assumes the user is aware of the types of protocol in use, and furthermore, the user made a determined effort to operate the reader in a mixed protocol mode. In this mode, the user can decide how many and which specific protocols to be selected. Once Mix Protocol Mode is selected, the reader will routinely cycle through each protocol, dwell long enough for the reader to wait for a response and then move on to the next protocol. It should be noted that in a mixed protocol mode, the tag must have sufficient time to respond to the reader, and therefore, it can only be used on a conveyor belt arrangement, with specific speed restrictions.

Single Protocol Mode

Single protocol is the normal mode of operation, where the protocol type is known and many tags are expected to pass through the readers.

5.2 USERS NOTE

For System Integrators and/or Software Developers

System Integrators and/or software developers should get familiar with the *MPR-1710 1712 Protocol* specifications for developing applications that control an MPR-1710.

For Custom System Users

For custom system user, please refer to your host software user guide for information regarding system and software operations

For Demo Software Users

If you are using the AWID RFID demonstration software application which is .NET based with easy-to-follow GUI operations, simply select the COM port for which the device is configured then click "Connect" should get you started.

6 MPR SERIAL COMMUNICATION PROTOCOL

See MPR-1710 Protocol Manual - 041377

Warning statements

This device complies with part 15 of the FCC rules.

Operation is subject to the following two conditions:

- (1) this device may not cause harmful interference, and
- (2) this device must accept any interference received, including interference that may cause undesired operation.

Note: The manufacturer is not responsible for any radio or TV interference caused by unauthorized modifications to this equipment. Such modifications could void the user's authority to operate the equipment.

ANT-915CPS-A

Rev.1.0 08/26/2006



Fig.1. Picture of the Circularly Polarized (RHCP) Patch Antenna

1. Specifications

- 1.1. Nominal frequency range from 900MHz to 930MHz
- 1.2. Max Gain = +5.70dBi
Min Gain = + 4.80dBi
- 1.3. The average Gain is +5.25dBi.
- 1.4. Circular polarized antenna - Polarization RHCP

ANT-915CPS-A

- 1.5. Axial ratio at boresight direction is less than 1.0dB (less than measurement tolerance).
- 1.6. -3dB beam width, horizontal 63 degree;
-3dB beam width, vertical 63 degree;
- 1.7. Front to back ratio 14dB;
- 1.8. Input impedance 50 Ohm
- 1.9. Connector: Reverse Polarity TNC 50 Ohm.
- 1.10. VSWR less than 1.12 over frequency range 900–930 MHz
- 1.11. VSWR degradation in proximity 12" (0.3m) to the flat metal surface
VSWR_{max}=1.18 over frequency range 900–930 MHz
- 1.12. Maximum input power 5W.
- 1.13. Dimension 10"x10"x1.45" (260mm x 260mm x 37mm) without connector.
- 1.14. Weight: 1.0 and 1/16 lbs (0.482kg).
- 1.15. This antenna may be used for European frequency band 865 – 870 MHz and Japan 952 -954 MHz with some degradation of the gain and axial ratio.
VSWR less than 1.18 over frequency range 865 – 955 MHz



Fig.2. Back view of the Circularly Polarized Patch Antenna

ANT-915CPS-A

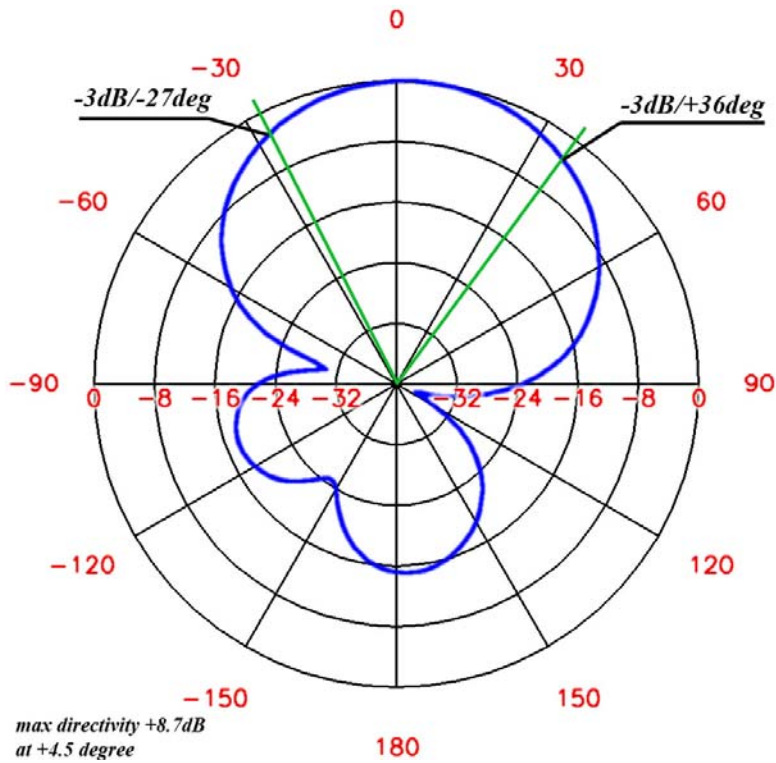

Fig.3. Normalized Logarithmic Directivity E_{teta} ,
 $\theta=0^\circ \dots \pm 180^\circ$, $\phi=0^\circ$.(Polar diagram)

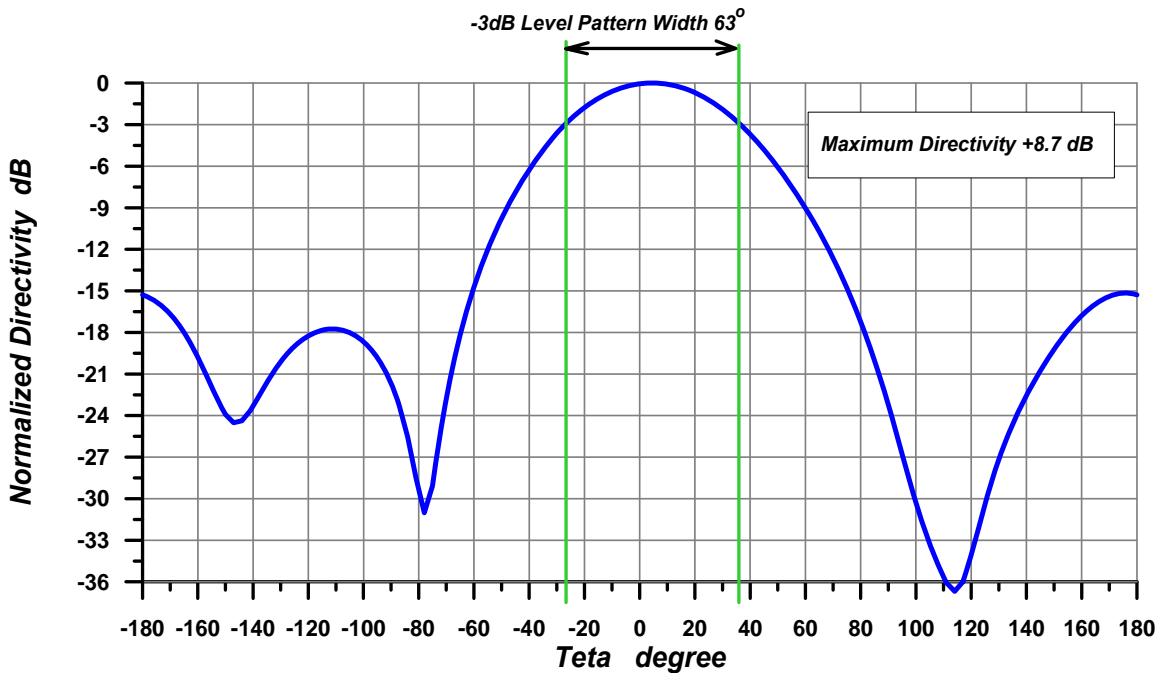

Fig.4. Normalized Directivity E_{teta} , $\phi=0^\circ$

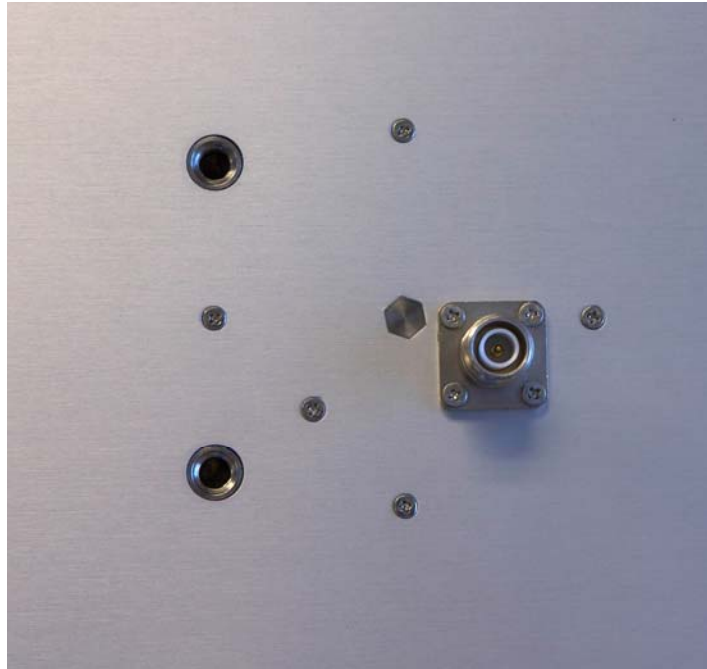

Fig.5. Antenna Mounting

On the backside of the antenna, there are two mounting holes:

Thread $\frac{1}{4}$ "-20 – diameter - $\frac{1}{4}$ "; threads per inch - 20.

Depth – $\frac{3}{8}$ ".

Distance between holes – $L1=1.97$ " (50mm).

DASH NO.	APPLICATION		REVISIONS			
	NEXT ASSY	USED ON	REV	DESCRIPTION	DATE	APPROVED
			Pre	PRELIMINARY ISSUE	7-31-2008	EH

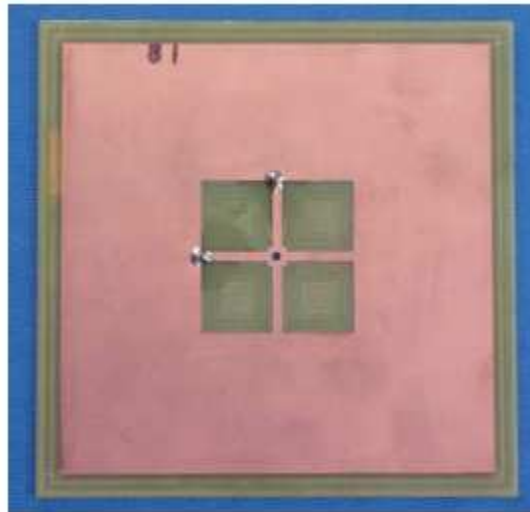

Antenna Specifications:

Type:	Circular Polarized Patch antenna
Antenna Gain:	4 dBi typical
Frequency Range:	902 to 928 MHz
Input Power:	4 Watts max
Input Impedance:	50 Ohm
Material:	FR4 PCB
Connector:	MMCX
Operational temperature:	-40°C to +60°C
Dimension:	5"x5"

AWID PROPRIETARY INFORMATION

ALL PAGES ARE ON ORIGINAL ISSUE (-) EXCEPT AS NOTED	CONTRACT NO:					
	ISSUED	DATE				
	PREP BY:		Specification for ANT-915-CPS-C			
	CHK BY:					
	REVIEW:					
	ENGR (PROJ):					
	APPVL (PPOJ):					
	APPVL:		SIZE	FSCM NO.	Doc. NO.	REV
			-	-	041390	-
			SCALE			

Directivity:

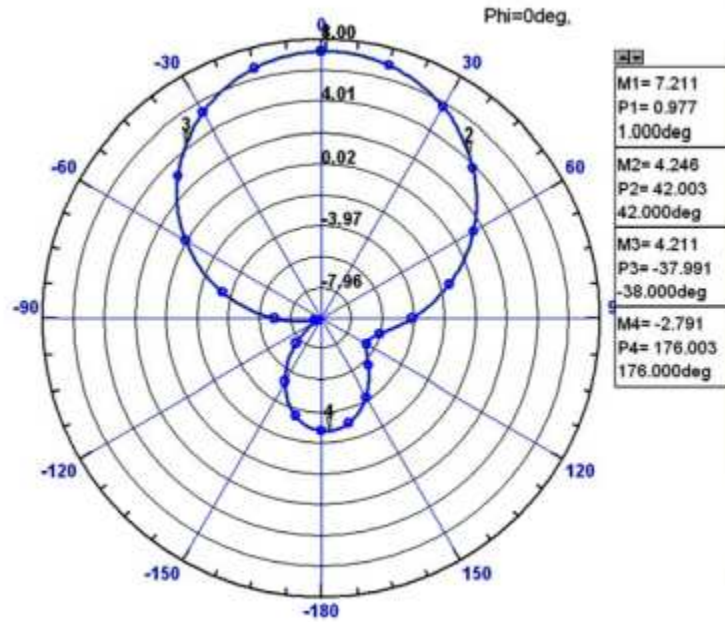

Gain:

Table 1. Maximum gain and axial ratio.

Frequency MHz	900	907	915	923	930
Maximum Gain dBi	+4.5	+4.7	+4.5	+4.1	+3.4
Axial Ratio in boresigth dB	1.7	1.5	1.3	1.1	0.9

DASH NO.	APPLICATION		REVISIONS			
	NEXT ASSY	USED ON	REV	DESCRIPTION	DATE	APPROVED
			Pre	PRELIMINARY ISSUE	1-12-2005	DL
			D	Bandwidth correction	3-5-2007	EH

THIS DRAWING INCOMPLETE WITHOUT ECN'S
None

AWID PROPRIETARY INFORMATION

ALL PAGES ARE ON ORIGINAL ISSUE (-) EXCEPT AS NOTED	CONTRACT NO:		 Applied Wireless Identifications APPLIED WIRELESS ID Monsey, NY USA			
	ISSUED	DATE				
	PREP BY: V. LTV		Design Specification for ANT-2010CP -- Serial Interface Reader			
	CHK BY:					
	REVIEW:					
	ENGR (PROJ):					
			SIZE	FSCM NO.	DWG NO.	REV
	APPVL (PPOJ):		A		041233	D
APPVL: D Lee		SCALE				

Revision Records:

Enter all revision records by stating "Paragraph Numbers," revision "From" and "To", "Revision Level" and "Time of Revision."

Rev D:

4.1.5 Changed "+/- 75 MHz" to "+/- 54 MHz", document control# in footer corrected, March 5, 2007

	SIZE	FSCM NO.	DWG #2010B-041233	March 5, 2007	
	A	SCALE	MPR-2012 ANT	page	2
			AWID PROPRIETARY	SHEET 2	REV D

1.0 Scope

This specification describes the electrical, mechanical and environmental requirements for circular polarized UHF antenna, designed to work in conjunction with MPR-2010A or MPR-2010B series of UHF RFID readers.

2.0 Applicable Documents

The following documents of the exact issue shown, form a part of this specification to the extent specified herein. In the event of conflict between this document and the documents referenced herein, the contents of this document shall prevail.

Specifications

Handbooks

Mil-HDBK-217E Reliability Prediction for Electronic Equipment

Standards

ISO-18000-6A/B ISO/IEC FCD 18000-6 (ISO/IEC JTC 1/SC 31/WG 4/SG 3)
EPC C1 & C0 EPC™ Tag Data Standards Version 1.1 Rev.1.22
EPC C1G2 EPC RFID Protocols Class-1 Generation-2 UHF RFID, V1.0.1
EPC 1.19 UCODE V1.19 (SL31C31 01) Functional Specification
Matrics Class 0 Tag “Write” Module Design Specification V1.1
Impinj Zuma (TBD)

3.0 Requirements

This RFID module shall transmit a CW or command signals to activate RFID tags in its zone of surveillance and this RFID module shall also decoded the backscattered signal from RFID tags.

3.1 Common Requirements

3.1.1 Form factor



The outline dimensions of the RFID antenna is shown in the photo and Figure 1 is the mechanical dimension details of the antenna unit. The antenna unit shall measured 8x9.5x1.0 inches.

	SIZE	FSCM NO.	DWG #2010B-041233	March 5, 2007	
	A	SCALE	MPR-2012 ANT	page 3	
			AWID PROPRIETARY	SHEET 2	REV D

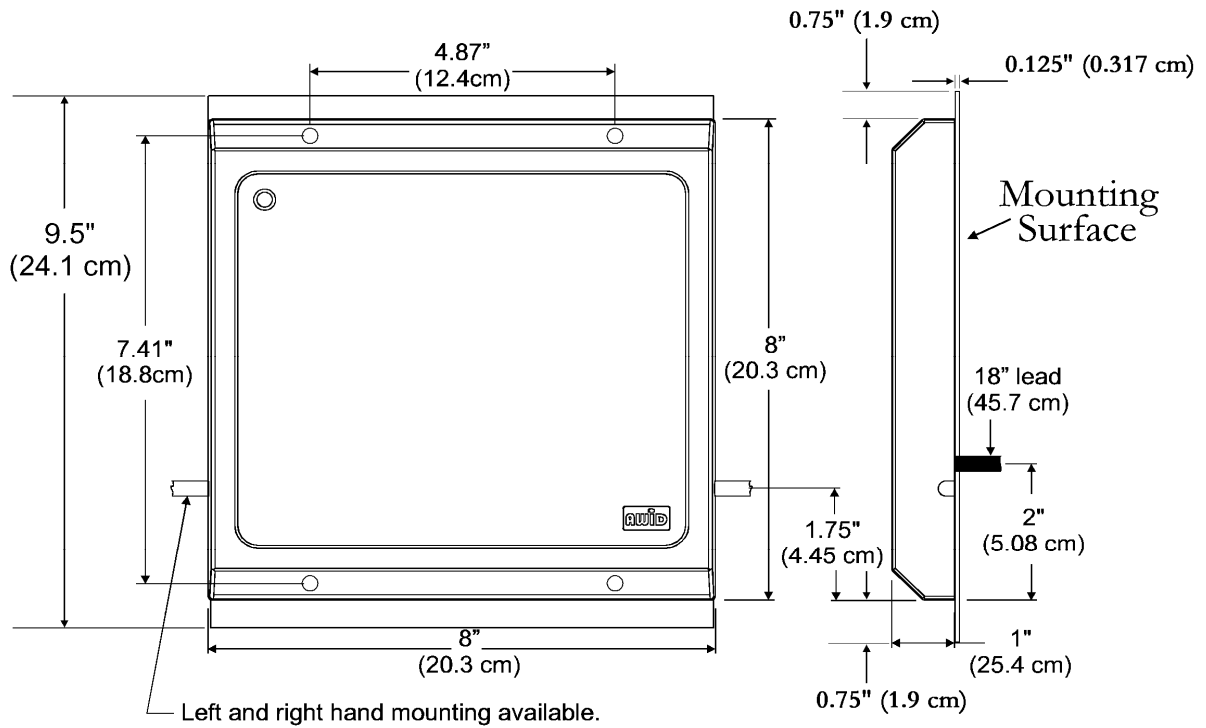

Note: remove cables and add SMA antenna

Figure 1, Mechanical Dimensions

3.1.2 Weight

This RFID module shall weigh less than 24 oz. (0.7 kg)

3.1.3 Power Supply and Consumption

N/A

3.1.4 Multi-protocol operations

Protocol agnostic.

3.2 Environmental Characteristics

3.2.1 General

This RFID module is intended for use in a fixed and/or mobile environment.

3.2.2 Cooling

Not required.

3.2.3 Temperature Change

-35 °C to +70 °C

	SIZE	FSCM NO.	DWG #2010B-041233	March 5, 2007	
	A	SCALE	MPR-2012 ANT	page	4
			AWID PROPRIETARY	SHEET 2	REV D

3.2.4 Humidity

The RFID module shall withstand the following humidity extremes:

Minimum -- 0% RH
Maximum -- 95% RH

3.2.5 Random Vibration -- TBD

3.2.6 Shock -- TBD

3.3 Electromagnetic Compatibility

TBD

3.4 Reliability Requirement

3.4.1 Component Selection -- TBD

3.4.2 De-Rating -- AWID's component de-rating guide.

3.4.3 MTBF TBD
Ground, Sheltered Benign

4.0 Antenna Electrical Specification

4.1 Frequency Characteristics

4.1.1 Operating Frequency -- 902 to 928 MHz center frequency

4.1.2 Gain -- 5.08 dB typical, 5.59 dB maximum

4.1.3 VSWR – 1.2:1 from 902 to 928 MHz

4.1.4 3-dB Pattern -- +/- 33° of free space pattern

4.1.5 3-dB Bandwidth -- +/- 54 MHz

4.1.6 Polarization -- Right hand or Left hand pattern

4.1.7 H/V Differential -- 0.5 dB

4.1.8 Front/Back Ratio -- 15 dB

4.1.9 Power Capability -- 5 Watts max.

4.1.10 Regional Code --
US – 902 to 928 MHz
China – 917 MHz (experimental)
Taiwan – 922 to 928 MHz
Singapore – 923 to 925 MHz
Koera (FHS) – 910 to 914 MHz
Korea (LBT) – 908.5 to 914 MHz
Australia – 918 to 926 MHz

4.1.11 Radiation Pattern --

See Figure 2

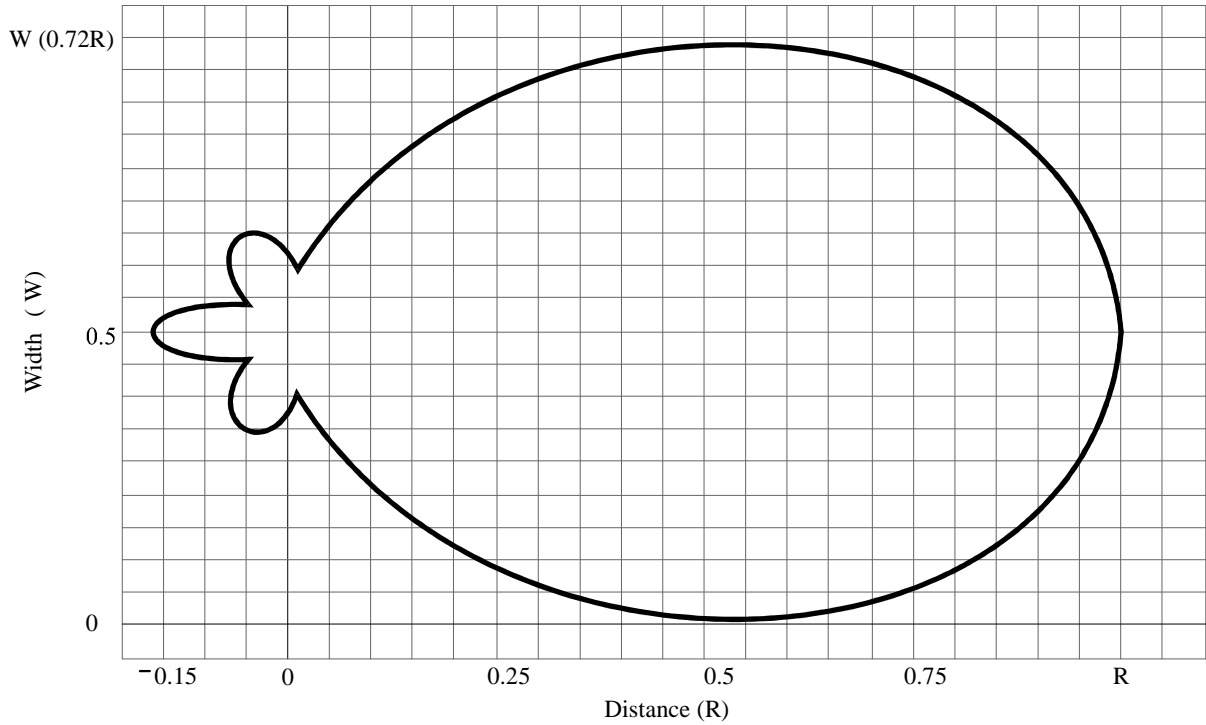

4.2 Interface with External Systems

4.2.1 **Input Connector --**

SMA (Reverse sex)

5.0 Marking

Antenna shall be marked with part number, hardware revision level and serial number.

6.0 Configuration Control

	SIZE	FSCM NO.	DWG #2010B-041233		March 5, 2007
	A			MPR-2012 ANT	page 6
		SCALE	AWID PROPRIETARY		SHEET 2