

Step 4: Bracket Weatherproofing

Weep hole plugs must be installed correctly

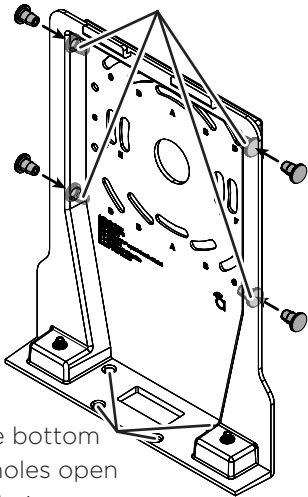

Leave bottom weep holes open for drainage

Pull cables through BEFORE installing foam pieces to avoid tearing the foam.

Use gaskets that best fit cable diameter

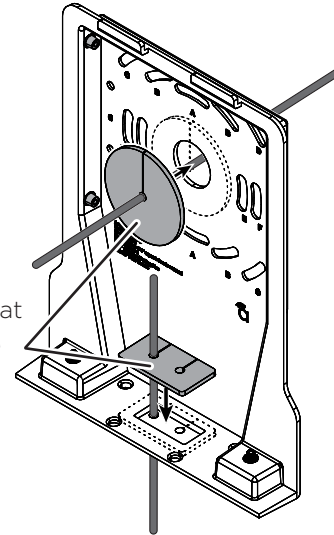

To ensure weatherproofing, insert gasket even if cable entrance is not used.



Step 4: Connect

Ⓐ Connections

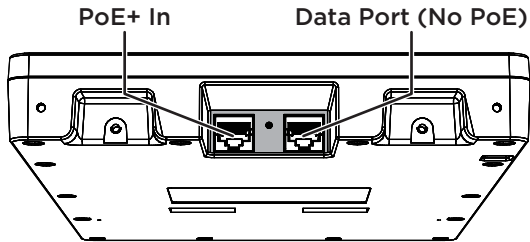

PoE+ Power Input Specifications

IEEE 802.3at Compliant Power Source

Power Consumption:

Typical: 18W

Peak: 23W

Ⓑ Install Cable Gasket

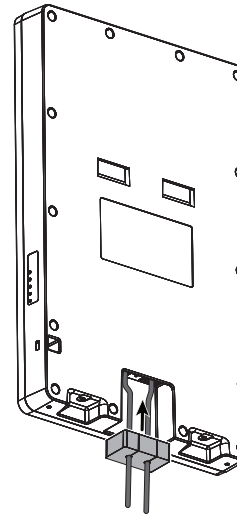

Foam block must be pushed to the back of the cable entrance with large holes facing connectors.

Remove the adhesive backing before installation.

NOTE: Leave the white dust cover in the non-PoE Data Port in place unless the port is being used. Use pliers to remove the dust cover.

Step 5: Secure

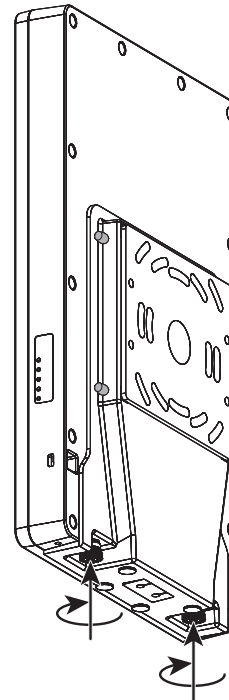
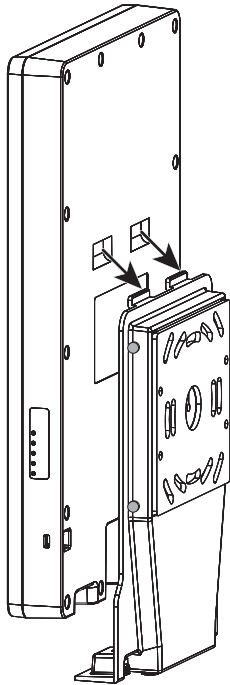



Step 6: Verify

- 5 GHz (Blue) - Off: Radio disabled
Solid: Radio enabled
Blinking: Radio activity
- 2.4 GHz (Blue) - Off: Radio disabled
Solid: Radio enabled
Blinking: Radio activity
- LAN 2 (Blue) - Off: No Ethernet link
Solid: Ethernet link established
Blinking: Ethernet link activity
- LAN 1 (Blue) - Off: No Ethernet link
Solid: Ethernet link established
Blinking: Ethernet link activity
- Power (Blue) - Off: No power to AP
Blinking: AP booting
Solid: AP ready

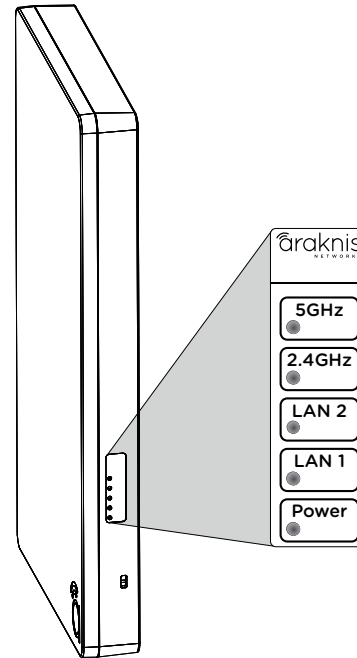



Step 7: Claim on OvrC

OvrC gives you remote device management, real-time notifications, and intuitive customer management, right from your computer or mobile device. Setup is plug-and-play, with no port forwarding or DDNS address required. To add this device to your OvrC account:

- (A) Connect the WAP to the Internet.
- (B) Log Into OvrC (www.ovrc.com) and create a or select a location to add the device.
- (C) Add the Device (MAC address and Service Tag numbers needed for authentication)

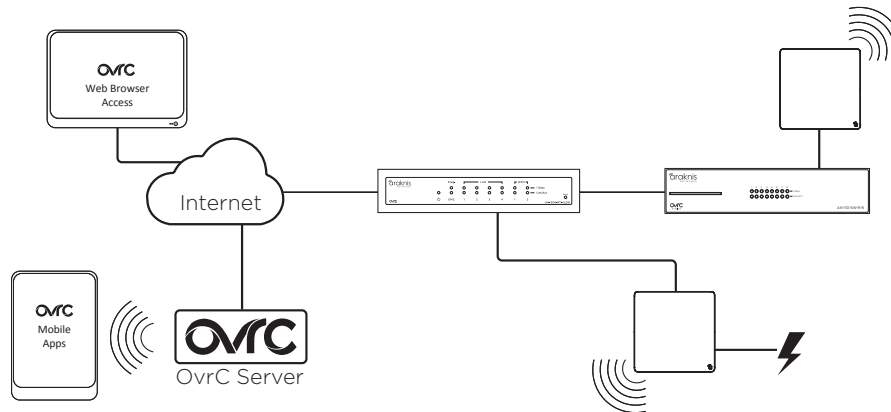



Step 8: Log Into Web Interface

- A Find the WAP in the OvrC device list, then click **Web Connect**.
- B Select whether you are on the LAN (I Am Local) or connecting over the Internet (I Am Remote).
- C Log in using the default credentials:

Username	araknis
Password	araknis

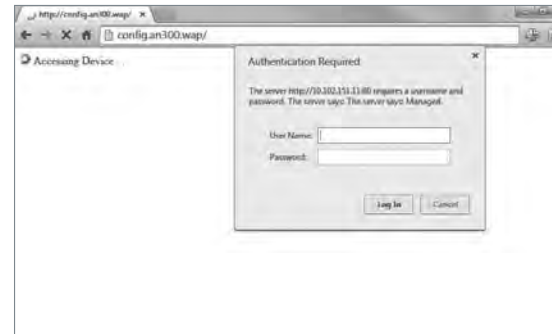

NOTE: If you can't connect to the WAP using this method, or need to configure the device before connecting it to the network, try these options for accessing your device:

- DHCP IP address - Page 18
- Default IP Address - Page 19



Pro Tip: Save and Apply Changes

After making changes to settings on a menu page, left-click the **Save** button on the menu to hold the new settings in the **Apply Changes** field.

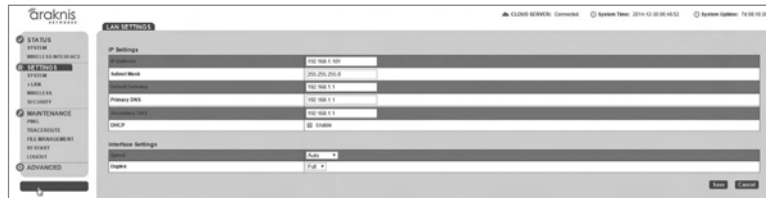

After all desired changes have been made, left-click **Apply Changes** to review the new settings. Left-click **Apply** to make the changes or **Revert** to cancel the changes.



NOTE: Settings will take affect after the progress bar completes 100%.



Other Access Methods: DHCP IP Address

The WAP is configured to DHCP by default so that the DHCP server can assign an IP address when the WAP is connected to the network (the DHCP server is usually the router). This address can be used for accessing the web interface.

Use one of these methods to find the IP address of the WAP:

- Check the client table on your router
- Use a network scanner (e.g. Fing) to sniff the network. The Araknis WAP manufacturer field will display “Snap AV”
See the highlighted field in the Fing screenshot to the right for an example of an Araknis device being identified.

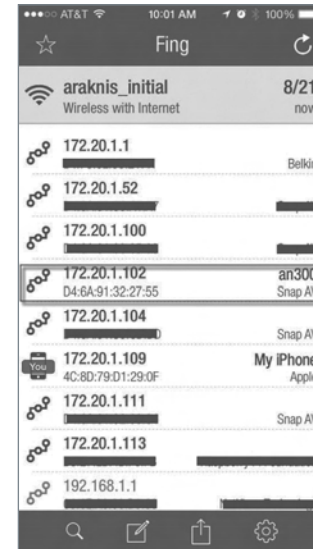



Other Access Methods: Default IP Address

If the WAP is not issued an IP address on the network, or needs to be accessed while not connected to a network, you can configure your computer's network connection to allow access using the default IP address, 192.168.20.253.

Windows 7 screenshots shown for reference.

(A) Connect your PC to the WAP using a network patch cable.

(B) On your PC, open the Control Panel and left-click **Network and Internet**.

(C) Left-click **Network and Sharing Center**.

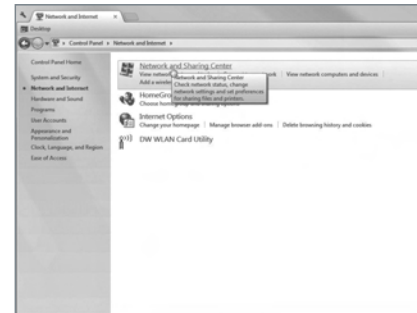
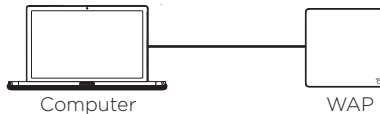



Other Access Methods: Default IP Address

Windows 7 screenshots shown for reference.

- (D) In the left bar, left-click **Change adapter settings**.
- (E) Right-click the icon for the wired network connection and left-click **Properties**.
- (F) Left-click to highlight **Internet Protocol Version 4 (TCP/IPv4)**, then left-click **Properties**.

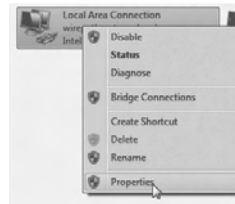
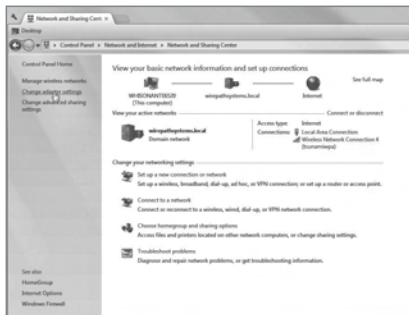



Other Access Methods: Default IP Address

Windows 7 screenshots shown for reference.

- Ⓒ In the **General** tab, left-click **Use the following IP address:** and enter the IP address and subnet mask.

IP Address	192.168.20.2
Subnet Mask	255.255.255.0

- Ⓓ Left-click **OK** to close Internet Protocol Version 4 (TCP/IPv4) Properties, then left-click **OK** to close wireless network connection properties.

- Ⓙ Open a browser and navigate to the IP address, 192.168.20.253. Log in using the default credentials:

Username	araknis
Password	araknis

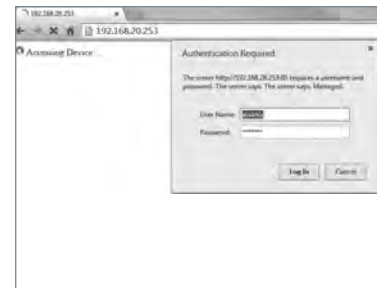



Troubleshooting: Reboot and Default Procedures

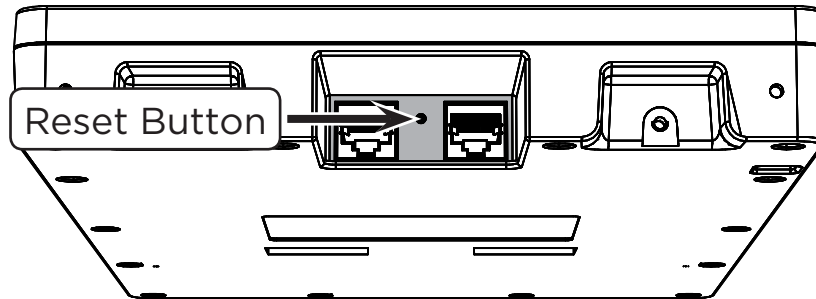

- Reboot - Press and release the RESET button. The device will reboot and no settings will be changed.
- Factory Default - Press and hold the RESET button for at least 15 seconds. The device will reset to factory defaults, then reboot.

Contacting Technical Support

(866) 838-5052

techsupport@araknisnetworks.com

2-Year Limited Warranty

Araknis Networks® products have a 2-Year Limited Warranty. This warranty includes parts and labor repairs on all components found to be defective in material or workmanship under normal conditions of use. This warranty shall not apply to products that have been abused, modified, or disassembled. Products to be repaired under this warranty must be returned to SnapAV or a designated service center with prior notification and an assigned return authorization (RA) number.



© 2017 Araknis Networks®

170628-1130