

# API

## CT

### User Manual



# Content

<b>Components</b>	3
<hr/>	
<b>H/W Parts</b>	
Device Functions	4
Device Settings	5
<hr/>	
<b>System Settings</b>	
Download & Install	7
How to Connect with Programm	8
<hr/>	
<b>Application Settings - Skin Tone</b>	
Application Settings	9
CRM	10
Analysis Skin Tone	11
<hr/>	
<b>Troubleshooting &amp; FAQ</b>	12
<hr/>	
<b>Warranty</b>	14

# Components

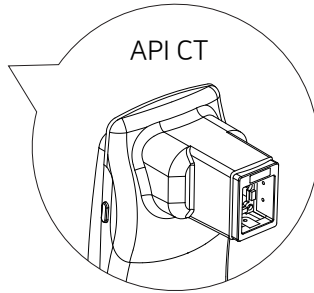
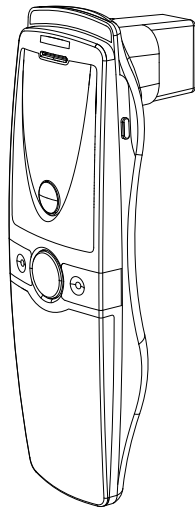

Main body

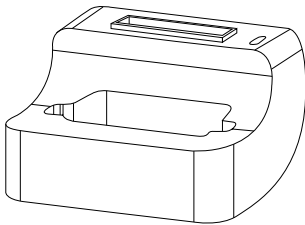

Cradle

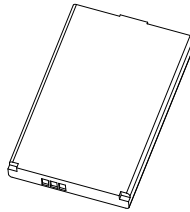

Battery

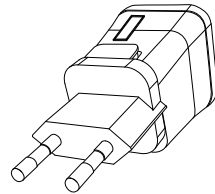

Charger

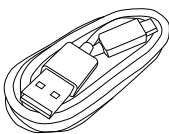

USB cable



Cleaning cloth

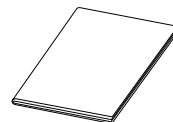

Manual

# Device Functions

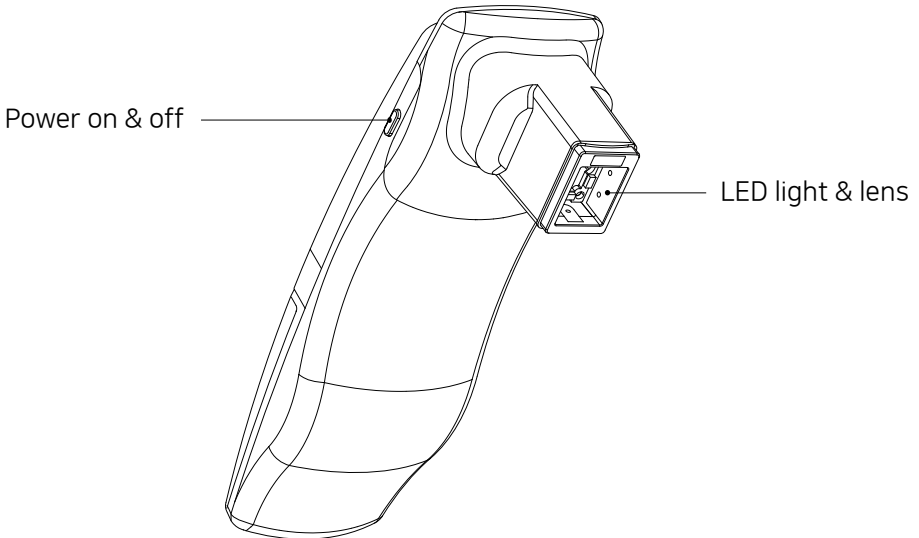
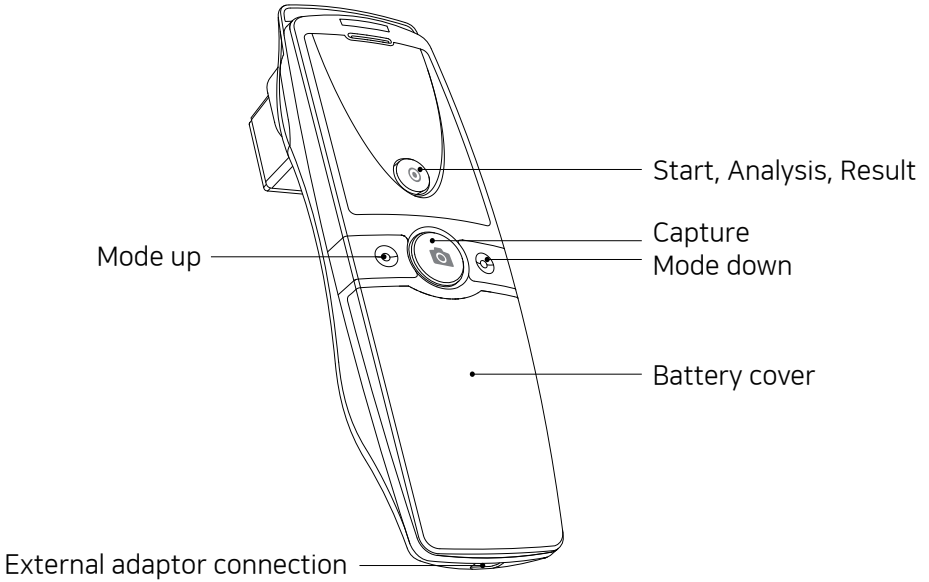

# Device Settings

## Insert the battery

- 1 Open the battery cover by pushing it down with finger.
- 2 Insert the battery and gently press the battery into place.
- 3 Close the cover.

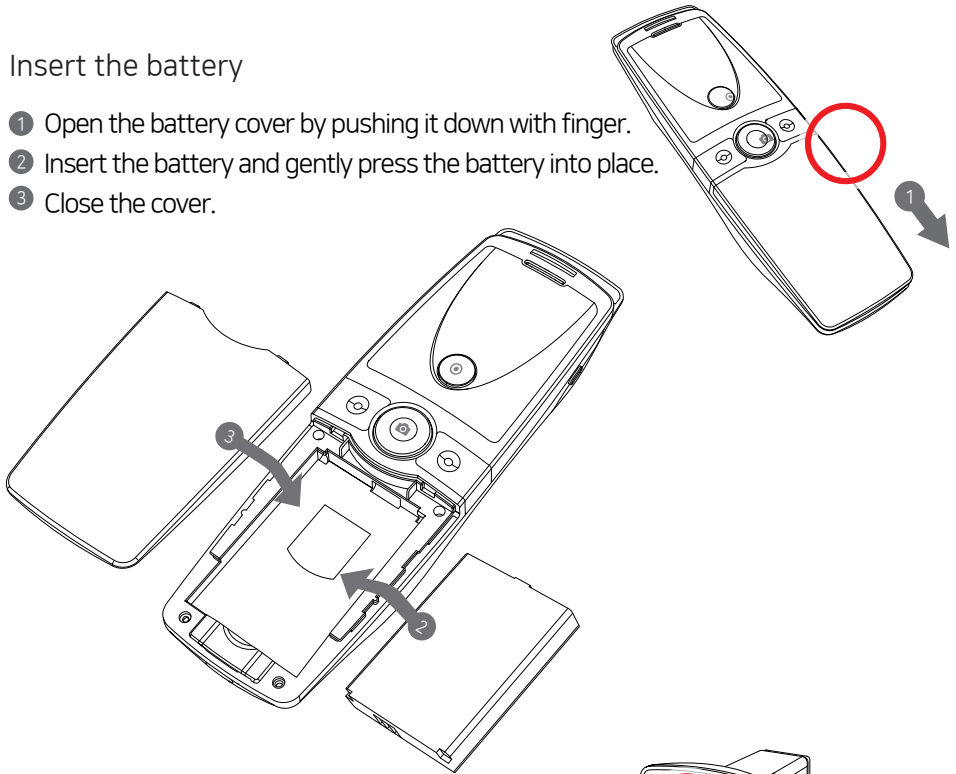

## To turn on the power

- 1 Press and hold "power" button.
- 2 "Indicate LED" starts twinkling in blue light.  
When it stops, the device is ready to use.

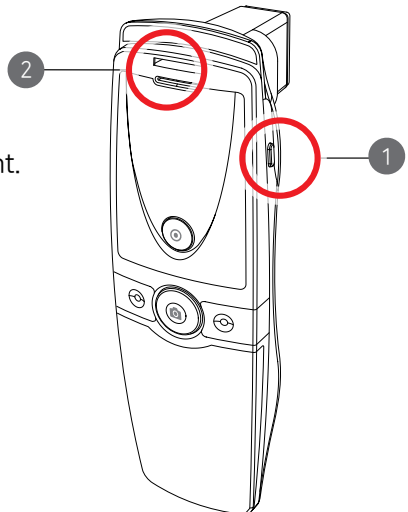

## To turn off the power

- 1 Press and hold "power" button.
- 2 "Indicate LED" will be turned off.

# Device Settings / Download & Install

Charger can be used for American type & European type. The default is European type.

① Push the plug up.

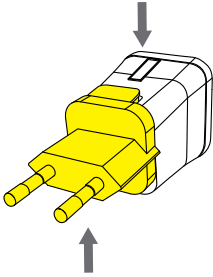

② Then 220V European type is disassembled and you can see the 110V-220V American type inside of the charger.

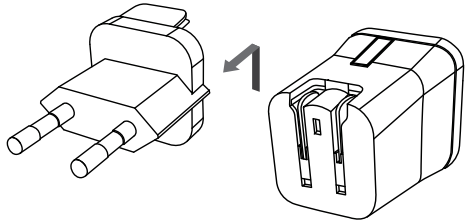

③ Choose the one you want to use and connect USB cable in adaptor.

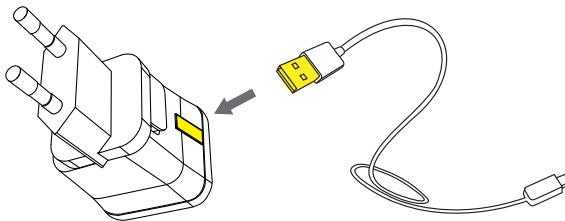

Tablet device or Smartphone user

- ① iOS : Go to "App Store" and search "Solutionist" to download the program.
- ② Android : Go to "Google Play Store" and download it.

# How to Connect with Program



Press ≡ button.

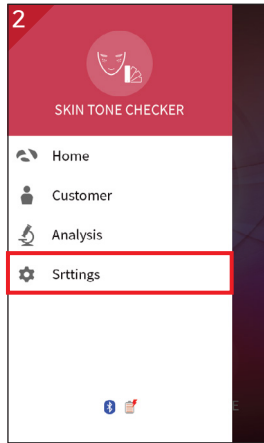

Touch ⚙ to "settings".

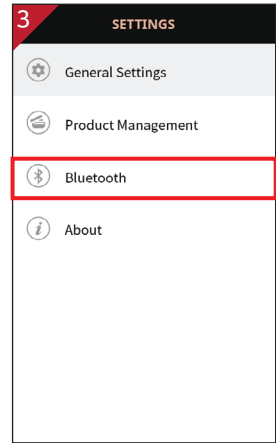

Go to "Blue tooth".



Bluetooth list will be appeared. Among the lists, select the Bluetooth connection you could use.

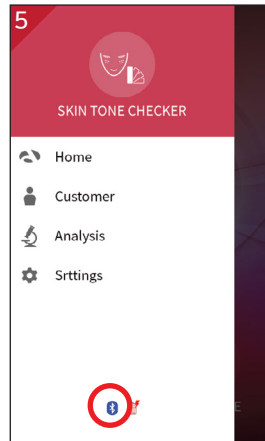

Wait until the device is connected to with Bluetooth.

# Application Settings



Press ≡ button.

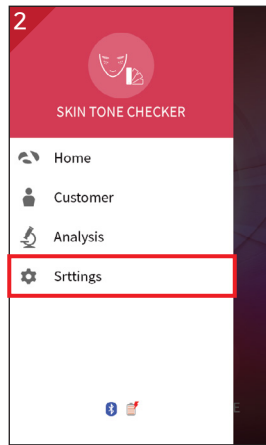

Go to "Settings".

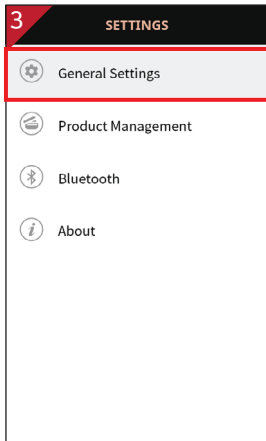

Go to "General Settings".

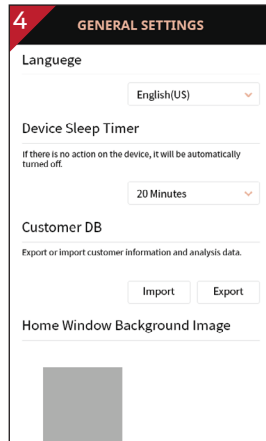

Language, version , email setting is available.



## CRM

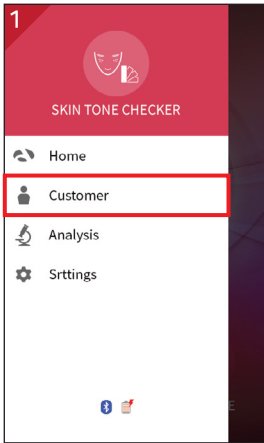

Touch "Customer".



Touch + to register new customer.

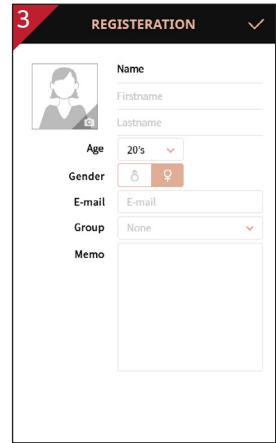

Input the information.

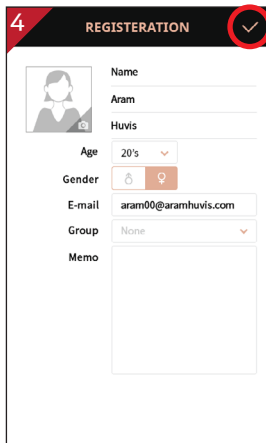

After putting all information, touch ✓.

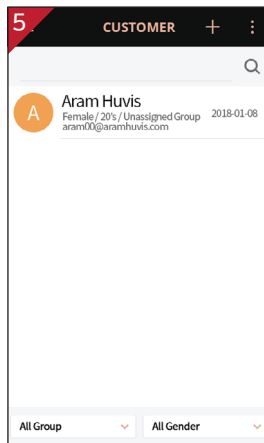

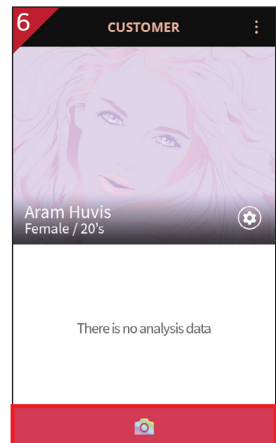

User's profile is created on the list. Then touch user's profile to start analyzing.

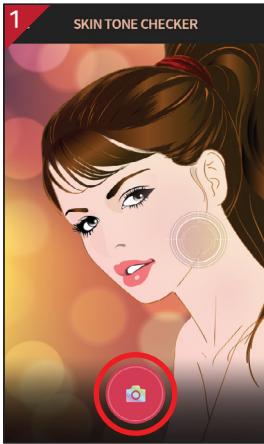

Touch 📷 button to start analyzing.

# Analysis Skin Tone



Touch the  button.  
\*All surface of the sensor should be pushed completely.

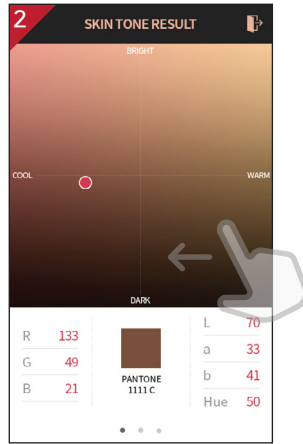

Checking your color tone and push slide to left.

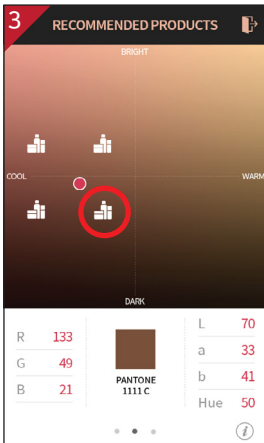

Please choose the icon of recommendation products near dots.



The window for Recommendation products pops up.

# Analysis Skin Tone

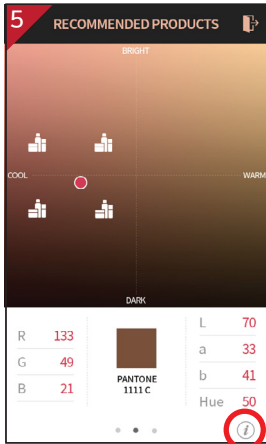

User may check the information of additional products by selecting (i) in the previous screen.



All recommendation products are shown according to each color.



Checking the best or the worst color according to each tone.

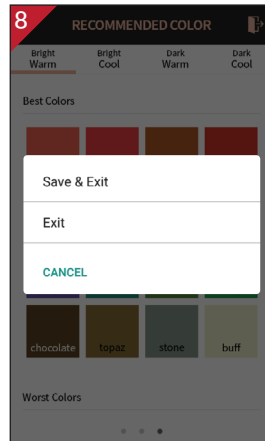

Please choose  for close and save.

# Troubleshooting & FAQ

- ① I cannot turn on the device.  
Connect and charge the device (or the battery) using the adaptor provided the supplier.  
(The battery charging indicator will be shown on the system main page.)
- ② I cannot power on the device even the battery is still full.  
The battery might be dislocated on the device. Please separate the battery from the device and put it on, and then power on again.
- ③ The battery is not charging very well.  
Separate the battery from the device and put it on again.  
Check the connection among a device, a battery and a charger.  
A battery cannot be charged if there is an alien substance on the charging port.  
In this case, please use the device after cleaning the charging port of the device or check whether the sticker is attached on charging port.
- ④ The using time of the battery is different from the manual.  
The battery using time will be shorten if you put the charged battery in a low or high temperature.  
The battery using time varies in service type, using environment, using period of the battery.  
The battery is consumed without using the device, and the battery using time will be shorten if you use additional functions of the device.
- ⑤ The device turns on but the diagnosis doesn't work.  
Check the smart card is correctly inserted (SD card slot on the button of the device.)
- ⑥ There are dust on the device.  
Clean the dust by using a smooth fabric. Do not use benzene, alcohol, and a synthetic detergent.
- ⑦ The screen is frozen and the keys not working when using the device.  
Separate the battery from the device and put it on again.  
If the device is still not working please contact to the customer service center.
- ⑧ A "force close" message appears on the screen.  
The repetition of commands can trigger a bug. Sometimes there may be a brief delay before the command is completed. Do not repeat/multiply the tasks as the device will no longer be able to follow them.
- ⑨ I cannot connect to Bluetooth  
Check the pairing status and try to re-pair the device with host device.

# Troubleshooting & FAQ

- ① The touchscreen doesn't react to my finger commands.  
Before using for the first time remove the protective plastic film.
- ② I cannot connect to Blue-tooth.  
Make sure to use the Bluetooth hosting devices that have Bluetooth certified with the logo.  
You may need an external Bluetooth dongle for those devices that do not have Bluetooth feature.  
Bring the device to closer with the Bluetooth hosting device.  
Try to re-pair the device with host device.  
The password of pairing is "0"(number).  
\* Blue-tooth function is not allowed to use in IOS device without APPLE'S official permission.
- ③ The screen was turned off.  
Press the on/off button to turn on the screen.  
The device has a power save function that turn the screen off after 1minute.  
For the setting, please refer to Page 8.
- ④ I can see the black screen only during measurement.  
Check the LED light inside lens on the head part when you try to measurement.  
If you cannot see the light, please contact the customer service via email or phone call.
- ⑤ The image is not clear.  
Tap the screen while capturing focus.

# Warranty

- ① The product undergoes strict quality management and inspection process before production and introduction to market.
- ② In case of functional or operational defect occurs under normal condition of use within 10 days after purchase, we will repair it for free or replace in new product.
- ③ When this product goes out under the normal use, we will repair it free of charge under warranty.
- ④ Please keep the warranty card when you ask for repair service.
- ⑤ Customer needs to pay repair charge after warranty runs out.
- ⑥ For this product, warranty period is 14 months from the Invoice date.
- ⑦ Cost
  - Within warranty : Sending delivery(Buyer), repair cost and returning delivery(Aram)
  - If the product is broken by user's fault, repair cost could be charged.
  - After warranty : Sending delivery and repair cost(Buyer), returning delivery(Aram)
- ⑧ How to send :
  - As sending a present from person to person by EMS or FEDEX.  
(Do not write the company name)
  - Total value should be under US \$99.(Write non-commercial value)

# Warranty

Service request form			
Date of purchase	/	/	Company
Contact person			
Address :			
Tel :			
Product name, serial No :			
Problems :			

PRODUCTION DIVISION & FACTORY (SHIPPING ADDRESS) :

#909 Byucksan Technopia, 560, Dunchon-daero, Jungwon-gu, Seongnam-si,  
Gyeonggi-do, 13230 Rep. Korea

Tel: 070-4687-1712 / Fax: 031-732-6330 / Email: support@aramhuvivis.com  
<http://www.aramhuvivis.com>



**HEAD OFFICE**

#401~402 Bundang Seoul National University Hospital Health Care Innovation Park, 172, Dolma-ro, Bundang-gu, Seongnam-si, Gyeonggi-do, 13605 Rep. Korea

**PRODUCTION DIVISION & FACTORY**

#909 Byucksan Technopia, 560, Dunchon-daero, Jungwon-gu, Seongnam-si, Gyeonggi-do, 13230 Rep. Korea

Tel: 070-4687-1712 / Fax: 031-732-6330 / Email: [info@aramhuvis.com](mailto:info@aramhuvis.com)  
<http://www.aramhuvis.com>



**FCC Compliance Statement**

This device complies with part 15 of the FCC rules. Operation is subject to the following two conditions: (1) This device may not cause harmful interference, and (2) this device must accept any interference received, including interference that may cause undesired operation.

**FCC Interference Statement**

This equipment has been tested and found to comply with the limits for a Class B digital device, pursuant to part 15 of the FCC Rules. These limits are designed to provide reasonable protection against harmful interference in a residential installation. This equipment generates, uses and can radiate radio frequency energy and, if not installed and used in accordance with the instructions, may cause harmful interference to radio communications. However, there is no guarantee that interference will not occur in a particular installation. If this equipment does cause harmful interference to radio or television reception, which can be determined by turning the equipment off and on, the user is encouraged to correct the interference by one of the following measures:

- Reorient or relocate the receiving antenna.
- Increase the separation between the equipment and receiver.
- Connect the equipment into an outlet on a circuit different from which the receiver is connected.
- Consult the dealer or an experienced radio/TV technician for help.

**FCC Caution**

Any changes or modifications not expressly approved by the party responsible for compliance could void the user's authority to operate this equipment. This transmitter must not be co-located or operating in conjunction with any other antenna or transmitter.