

ASI

User Manual



Contents

A. Components	2
<hr/>	
B. H/W Parts	
i. Both Sides	3
ii. Settings	4
<hr/>	
C. System Settings	
i. Download & Install	6
ii. How to connect with the program	7
iii. Wi-Fi Combo	8
<hr/>	
D. Program Settings	11
i. Device Certification	12
<hr/>	
E. Application	
i. Start Analysis	14
ii. Full Analysis	
CRM	15
Moisture	16
Sebum	17
Pore	18
Melanin	19
Acne	20
Wrinkle	21
Sensitivity	22
Summary	23
iii. View Mode	24
<hr/>	
F. Warranty	25
<hr/>	
G. FCC	27

※ Notes on use

- The images of this manual can be different with the actual things.
- The information contained in this manual and future improvements are subject to change without notice.
- The latest version of the manual will be updated at the below link.

<http://www.aramhuis.com/downloads>

Components

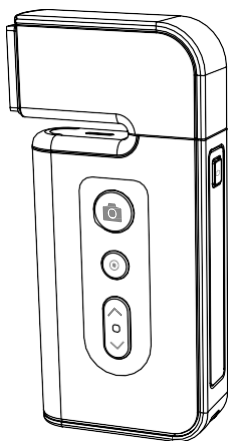

Main body with skin lens (ASI100)

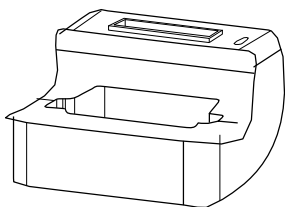

Cradle

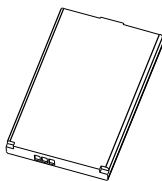

Battery

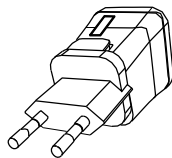

Charger

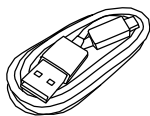

USB cable



Sebum paper 1 box



Cleaning cloth

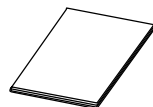

Manual

H/W Parts

Both Sides

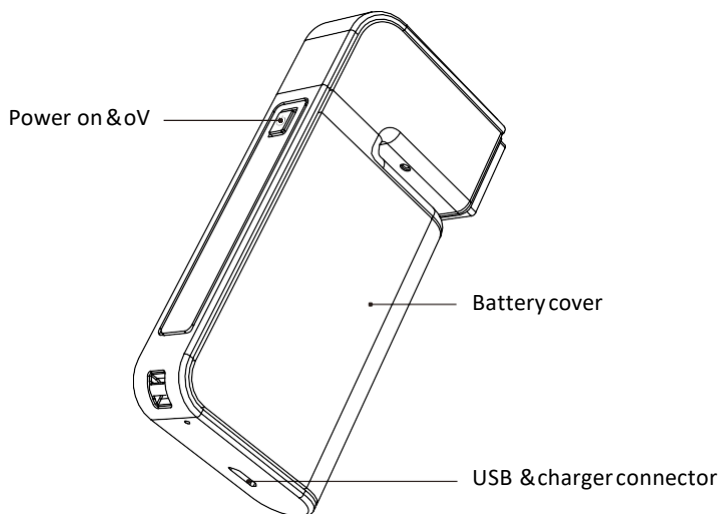
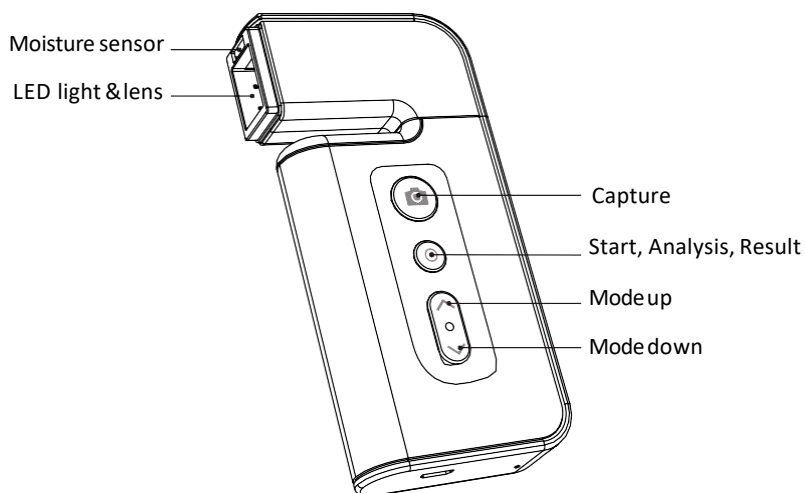

H/W Parts

Settings

Insert the battery

- 1 Open the battery cover by pushing it left to right with thumbs.
- 2 Insert the battery and gently press the battery into place.
- 3 Close the cover.

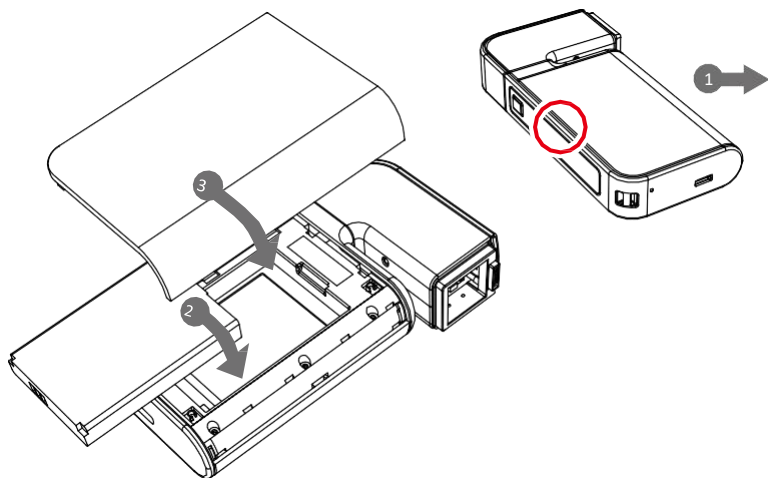

To turn on the power

- 1 Press and hold "power" button.
- 2 "Indicate LED" starts twinkling in blue light.
When it stops, the device is ready to use.

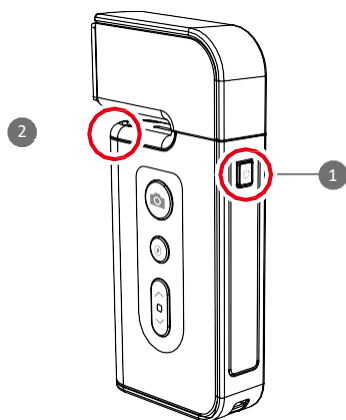

To turn off the power

- 1 Press and hold "power" button.
- 2 "Indicate LED" will be turned off.

H/W Parts

Settings

Charger can be used for American type & European type.
The default is European type .

1 Push the plug up.

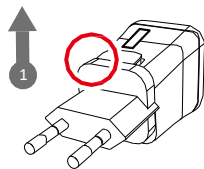

2 Then 220V European type is disassembled
and you can see the 110V-220V
American type inside of the charger.

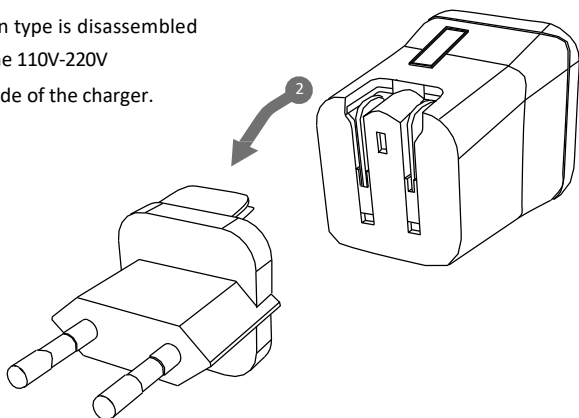

3 Choose the one you want to use and connect USB cable in adaptor.

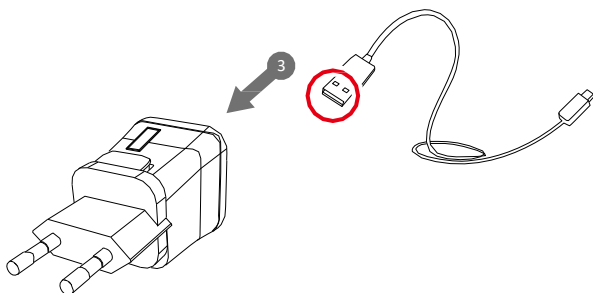

System Settings

Download & Install

PC User

1 Go to link on the browser as below.

<http://www.aramhuvis.com/downloads>

2 Install the program.

Tablet device or Smartphone user

1 iOS : Go to “App Store” and download application.

2 Android : Go to “Google Play Store” and download it.

*Charge ASI device. It is possible to operate ASI device while charging, but it is recommended to charge the device at least an hour if the battery was totally depleted.

*The micro USB port does not support data transfer.

System Settings

How to connect with the program

- 1 First of all, check the Wi-Fi name and password which is described at back side of battery cover.
- 2 Wi-Fi name & password must be same and the format is "ASI_XXXX".
- 3 Turn on the device.
- 4 While turning on the device, prepare PC, Tablet, Smartphone to run the S/W.
- 5 Once "ASI" device is turned on, please go to network setting to set up the Wi-Fi connection.
- 6 Among Wi-Fi lists, find "ASI_XXXX" and select it.
- 7 When above code is connected, run the program "Solutionist".
- 8 To check working properly, please check the program and see the leh below side.
- 9 If it is correctly set up, you can see the orange light of Wi-Fi singal.

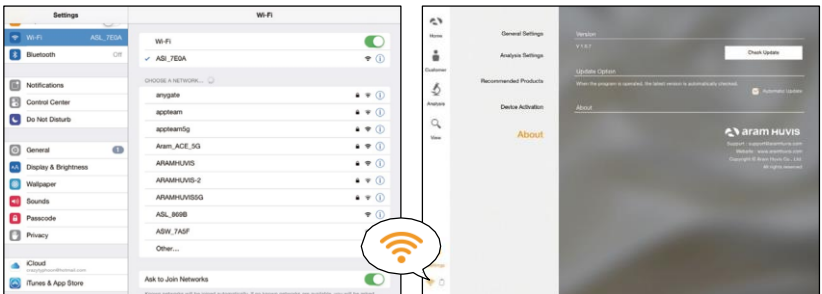
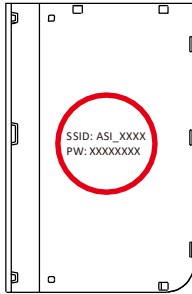

System Settings

Wi-Fi Combo

Wi-Fi Combo

- It means user could use device and internet at the same time.
- With this function, user can send an email after analysis immediately.

How to use?

- 1 The device has AP(ASI_XXXX) to be connected with the program "Solutionist" by Wi-Fi.
- 2 First of all, connect the device to AP to use it with "Solutionist".
- 3 Run "Solutionist".

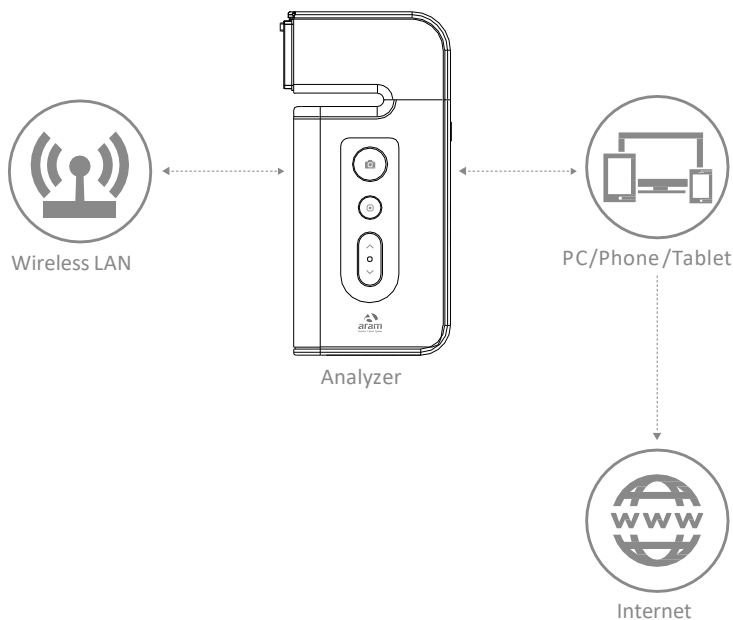

System Settings

Wi-Fi Combo

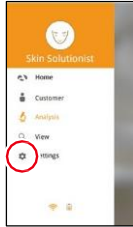

1 Touch Settings.

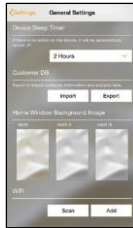
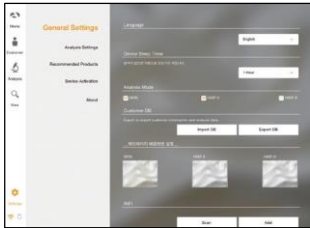

2 In "General Settings", go to "Wi-Fi" and touch "Scan" button.

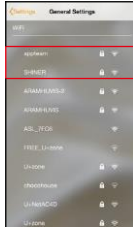
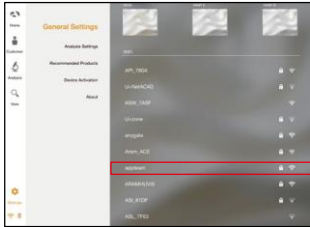

3 The available Wi-Fi lists appear. Among them, please choose the best signal Wi-Fi to connect it.

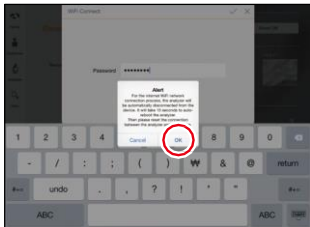

4 During connect it, you can see the message saying that ASI device will be automatically disconnected and reboot. Please touch "OK" button.

System Settings

Wi-Fi Combo

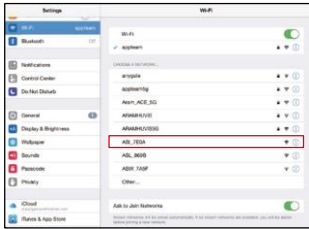

- 1 When Wi-Fi is connected, please go to “Settings” page to set up the Wi-Fi connection. You can see now the Wi-Fi is connected. Please turn it off and connect with device AP code (ASI_XXXX).

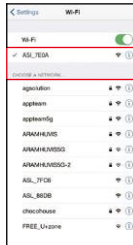
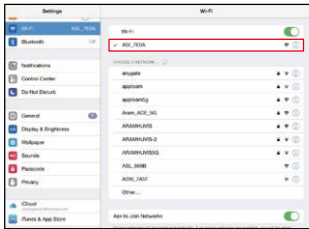

- 2 The analyzer is connected with AP code.



- 3 Then, run “Solutionist” program.

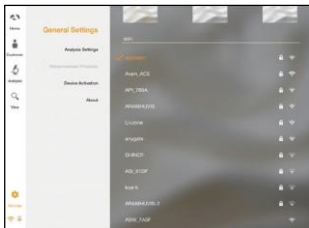

- 4 Then go to the settings again. The selected AP will be checked as leh. The Wi-Fi combo is done.

Program Settings

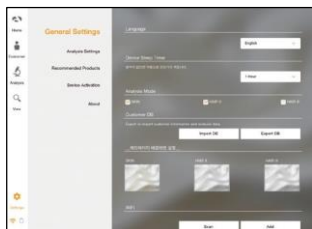

- 1 **General Settings**
Change the language, analysis mode and etc.

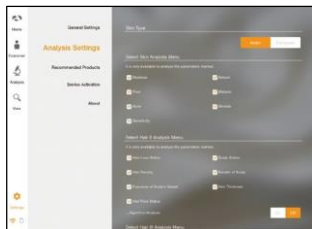
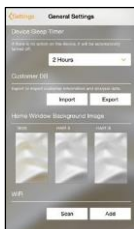

- 2 **Analysis Settings**
Set up the skin type and analysis parameter.

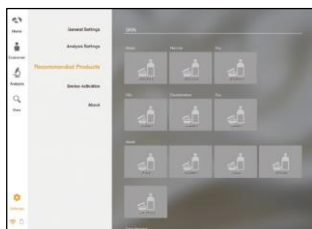

- 3 **Recommended Products**
Available for each analysis result.

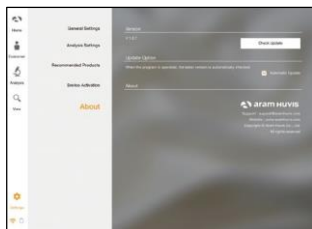

- 4 **About**
Check the current version and update is available in Wi-Fi connection.



Program Settings

Device Certification

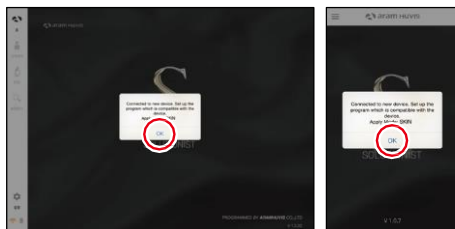

- 1 Solutionist program includes three programs.
But when you start "Solutionist" program with ASI-100 device you can see the pop message saying that the program is compatible with only "SKIN" device.
Touch "OK" button.



- 2 Then you will see now only "SKIN" program is activated.
On main menu, touch "Settings".

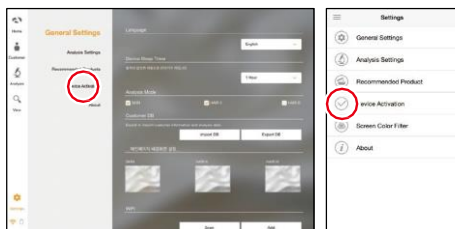

- 3 Among the menu, please select "Device Activation".

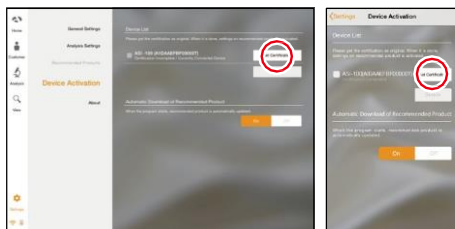

- 4 There is a device model name with serial code.
Please touch "Get Certification" to register the device in program.

Program Settings

Device Certification

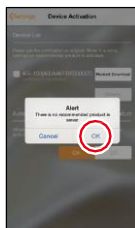
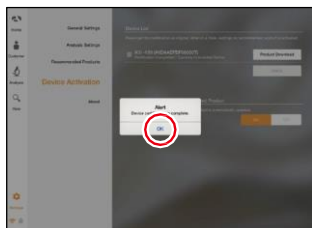

- 5 Device certification is complete. Please touch "OK" button.

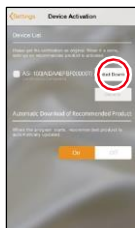
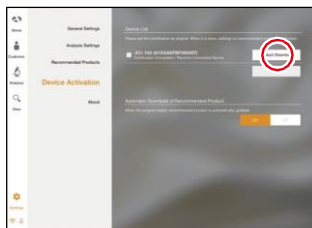

- 6 When it is done, you could touch "Product Download" button to load in server.

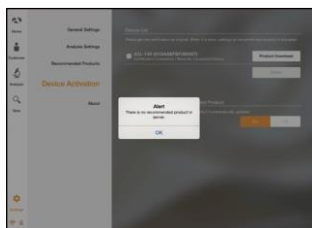

- 7 If you have the recommended product data in server, the product will be downloaded by clicking "Product download". If you do not have the recommended product data, you can see the message as leh image.

Applicaton

Start Analysis

1 Touch "Analysis" to start.

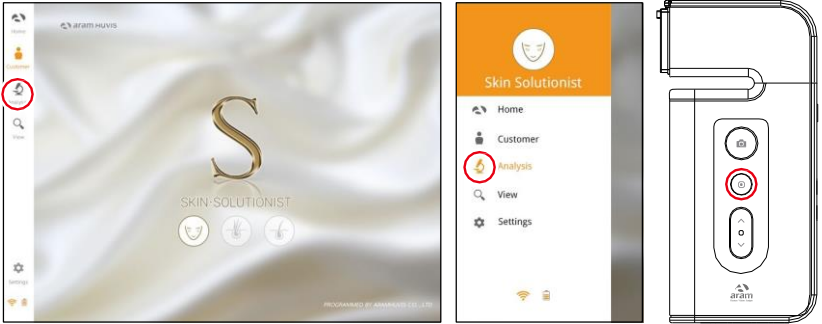

Remote Control (Only Tablet)

- 1 During analysis, you can control the device in "Solutionist" program.
- 2 In screen, touch "Control Menu On" to activate "Remote".
- 3 You can make use of this function in all analysis pages.

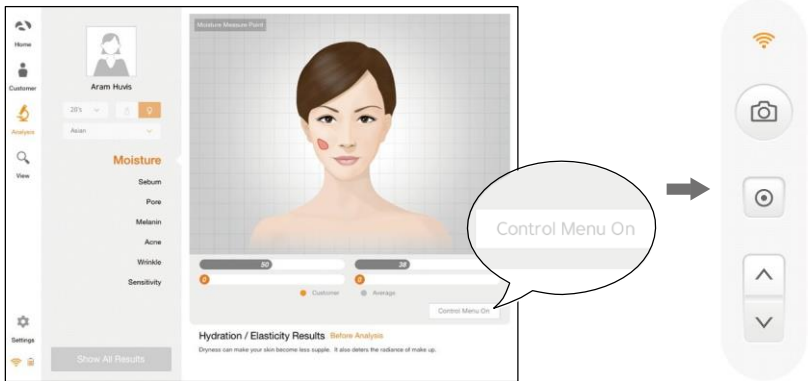

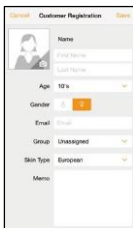
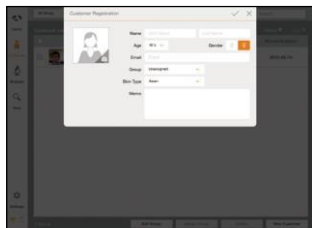

- 1 Input the information.
- full name, email address, gender and agegroup

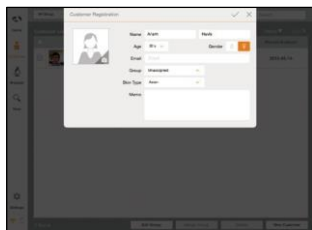

- 2 Take picture of customer's face with built-in camera or use the picture you already have in device.

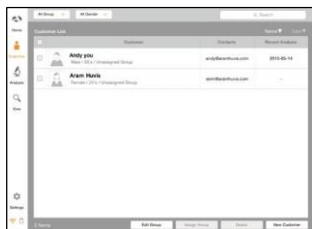

- 3 Among the customer lists, select the client to check or start analysis.

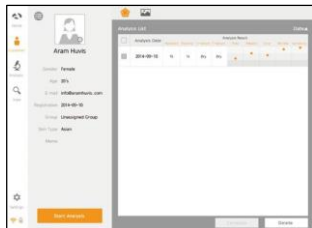

- 4 Check the customer information and analysis result list.

Applicaton

Moisture

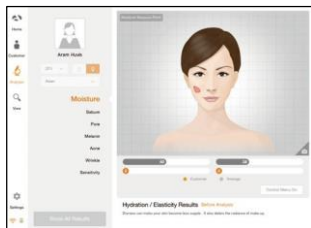

- 1 Press "capture" button and when you hear "beep" sound, please put the sensor onto your skin and wait until you hear "beep" sound again.



Moisture sensor



- 2 The result will appear. To analyze the next step, touch the below button.

Appleton

Sebum



- 1 Put the sebum paper onto the U-zone on the cheek, then press it for 2~3 seconds.



U-zone

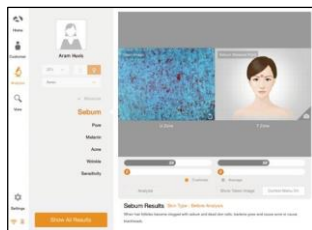

- 2 Place camera on the pink area and take picture. (U-zone)



Sebum paper

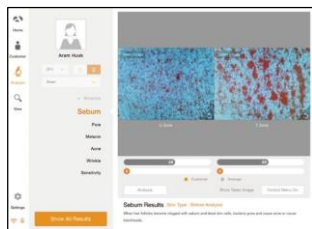

- 3 Put the sebum paper onto the T-zone on face, then press it for 2~3 seconds. Place camera on the pink area and take picture.(T-zone)



T-zone



Sebum paper

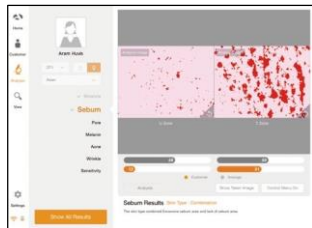

- 4 The result will appear. To analyze the next step, touch the below button.

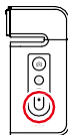

or



Applicaton

Pore

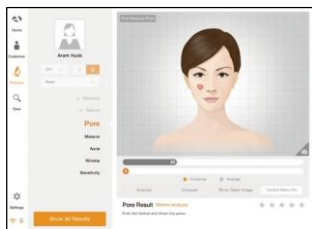

1 Touch button to activate camera mode.

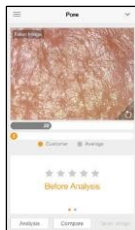
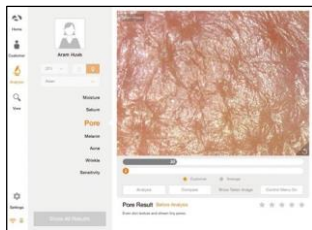
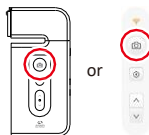

2 Put the camera onto the skin and touch button to capture the image. Then touch button to analyze it.

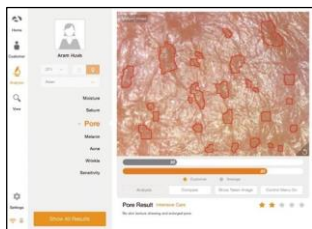

3 The result will appear. Touch "Compare" button to check the sample images as 4. To analyze the next step, touch the below button.



4 Compare your image with 3 sample images.

- Good
- Normal
- Bad

Applicaton

Melanin

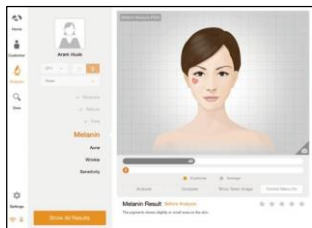

1 Touch button to activate camera mode.

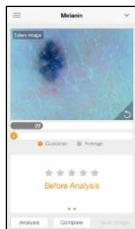
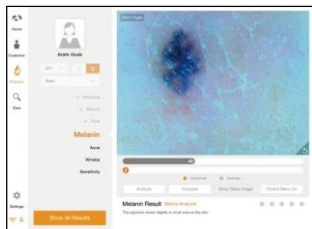

2 Put the camera onto the skin and touch button to capture the image. Then touch button to analyze it.

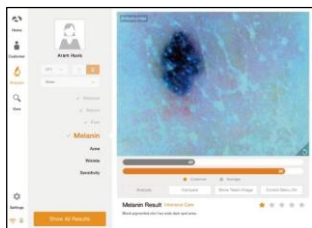

3 The result will appear. Touch "Compare" button to check the sample images as 4. To analyze the next step, touch the below button.

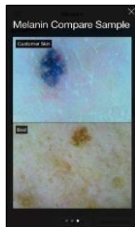

4 Compare your image with 3 sample images.

- Good
- Normal
- Bad

Applicaton

Acne

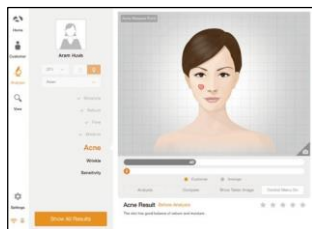

- 1 Touch button to activate camera mode.

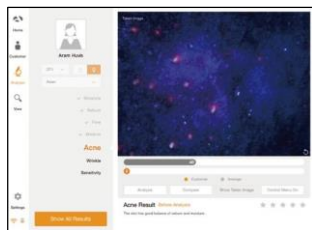
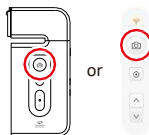

- 2 Put the camera onto the skin and touch button to capture the image. Then touch button to analyze it.

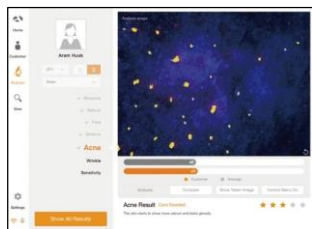

- 3 The result will appear. Touch "Compare" button to check the sample images as 4. To analyze the next step, touch the below button.

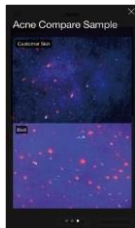
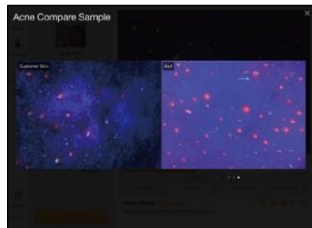

- 4 Compare your image with 3 sample images.
- Good
 - Normal
 - Bad

Appleton

Wrinkle

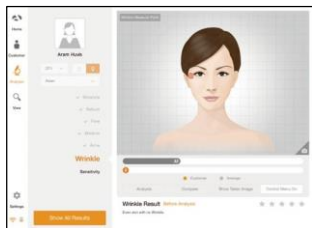

- 1 Touch button to activate camera mode.

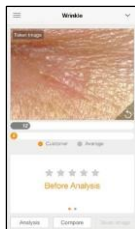
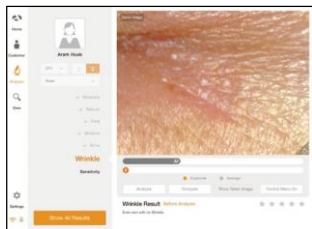

- 2 Put the camera onto the skin and touch camera button to capture the image. Then touch analyze button to analyze it.

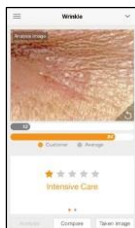
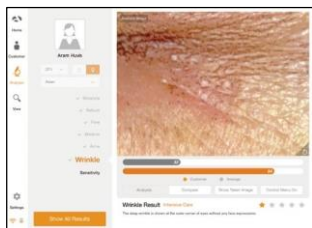

- 3 The result will appear. Touch "Compare" button to check the sample images as 4. To analyze the next step, touch the below button.

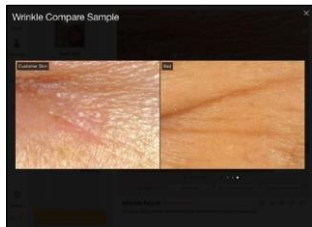

- 4 Compare your image with 3 sample images.
- Good
 - Normal
 - Bad

Applicaton

Sensitivity

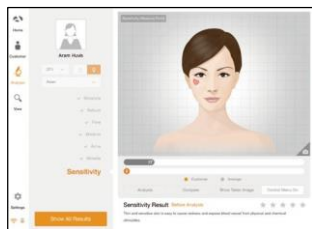

- 1 Touch button to activate camera mode.

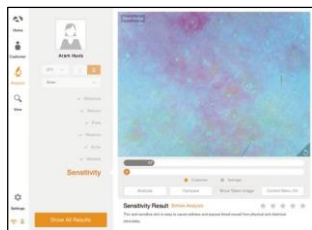

- 2 Put the camera onto the skin and touch button to capture the image. Then touch button to analyze it.

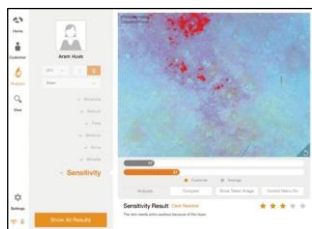

- 3 The result will appear. Touch "Compare" button to check the sample images as 4. To check all the results, touch "Show All Results" or the below button.

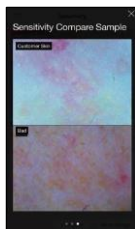

- 4 Compare your image with 3 sample images.
 - Good
 - Normal
 - Bad

Applicaton

Summary



1 Check the result.



2 Touch **o** button or each parameter's name on pentagon graph. Once you select "Show Recommended Product", product image will pop up as 



3 Available to check product image.

Applicaton

View Mode

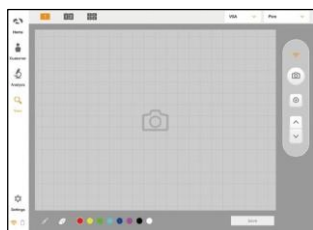

1 In view mode, it is able to take pictures with capture button in many times.

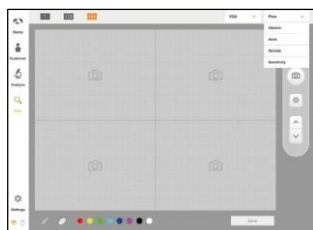

2 The user can select analysis parameter to take picture.

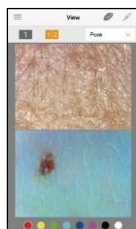
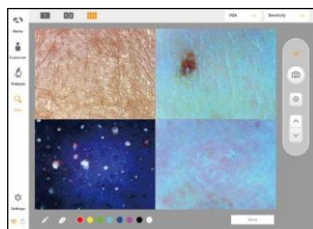

3 In one screen, you can see 4 different images maximum.

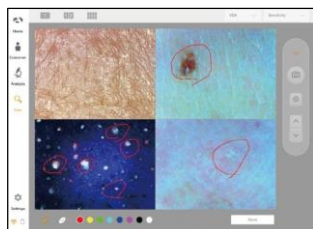

4 The user can mark the defect or concern according to the image with note function.

Warranty

- 1 The product undergoes strict quality management and inspection process before production and introduction to market.
- 2 In case of functional or operational defect occurring under normal condition of use within 10 days after purchase, we will repair it for free or replace in new product.
- 3 When this product goes out under the normal use, we will repair it free of charge under warranty.
- 4 Please keep the warranty card when you ask for repair service.
- 5 Customer needs to pay repair charge after warranty runs out.
- 6 For this product, warranty period is 14 months from the Invoice date.

Cost

Within warranty : Sending delivery(Buyer), repair cost and returning delivery(Aram)

- If the product is broken by user's fault, repair cost could be charged.

After warranty : Sending delivery and repair cost(Buyer), returning delivery(Aram)

How to send :

-As sending a present from person to person by EMS or FEDEX.

(Do not write the company name)

- Total value should be under US \$99.(Write non-commercial value)

Warranty

Service request form			
Date of purchase	/ /	Company	
Contact person			
Address :			
Tel:			
Product name, serial no :			
Problems :			

Shipping address:

#909 Byucksan Technopia, 560, Dunchon-daero, Jungwon-gu, Seongnam-si,
Gyeonggi-do, 13230 Rep. Korea

E-mail : support@aramhuvis.com

Tel : +82 70 4687 1712 / Fax : +82 31 732 6330

FCC Compliance Statement

This device complies with part 15 of the FCC rules. Operation is subject to the following two conditions: (1) This device may not cause harmful interference, and (2) this device must accept any interference received, including interference that may cause undesired operation.

FCC Interference Statement

This equipment has been tested and found to comply with the limits for a Class B digital device, pursuant to part 15 of the FCC Rules. These limits are designed to provide reasonable protection against harmful interference in a residential installation. This equipment generates, uses and can radiate radio frequency energy and, if not installed and used in accordance with the instructions, may cause harmful interference to radio communications. However, there is no guarantee that interference will not occur in a particular installation. If this equipment does cause harmful interference to radio or television reception, which can be determined by turning the equipment off and on, the user is encouraged to correct the interference by one of the following measures:

- Reorient or relocate the receiving antenna.
- Increase the separation between the equipment and receiver.
- Connect the equipment into an outlet on a circuit different from which the receiver is connected.
- Consult the dealer or an experienced radio/TV technician for help.

FCC Caution

Any changes or modifications not expressly approved by the party responsible for compliance could void the user's authority to operate this equipment. This transmitter must not be co-located or operating in conjunction with any other antenna or transmitter.

FCC Radiation Exposure Statement

IEEE 802.11b or 802.11g operation of this product in the USA is firmware-limited to channels 1 through 11.

Memo

Memo

Memo



HEADOFFICE

Rm401-402, 172, Dolma-ro, Bundang-gu, Seongnam-si, Gyeonggi-do, 13605 Rep. Korea

PRODUCTION DIVISION & FACTORY

#909 Byucksan Technopia, 560, Dunchon-daero, Jungwon-gu, Seongnam-si, Gyeonggi-do, 13230 Rep. Korea

Tel: 070-4687-1712 / Fax: 031-732-6330 / Email: info@aramhuvis.com

<http://www.aramhuvis.com>