

OWNERS AND SERVICE MANUAL

INNOVATIVE CONCEPTS IN ENTERTAINMENT INC.

10123 MAIN STREET, CLARENCE, NY 14031

SERVICE: 1-716-759-0360

FAX: 1-716-759-0884

E-MAIL: service@icegame.com

WEBSITE: www.icegame.com

Table of Contents

Safety and Warnings	4
Game Play	5
Setup Configuration	6
Dipswitch Settings	7
Mode Settings	8
Determine your Cost of prizes	10
Power supply information	11
Error codes and solutions	12
Board layout w/connectors	13
Wiring - Power, joysticks, and buttons	14
Wiring - Claw and coin.	15
Wiring - Motors	16
Tilt Adjustment	17
Cabinet and door glass replacement	18
Spares	19-20
Warranty	21

Rev: E

August 16, 2012

SAFETY AND WARNINGS BEFORE YOU BEGIN

WARNING: WHEN INSTALLING THIS GAME, A GROUNDED A.C. RECEPTACLE MUST BE USED. FAILURE TO DO SO COULD RESULT IN INJURY TO YOURSELF OR OTHERS. FAILURE TO USE A GROUNDED RECEPTACLE COULD ALSO CAUSE IMPROPER GAME OPERATION, OR DAMAGE TO THE ELECTRONICS.

NOTE: THIS GAME IS INTENDED FOR INDOOR USE ONLY.

DO NOT DEFEAT OR REMOVE THE GROUNDING PRONG ON THE POWER CORD FOR THE SAME REASON AS GIVEN ABOVE. USING AN IMPROPERLY GROUNDED GAME COULD VOID YOUR WARRANTY.

HAVE A QUALIFIED ELECTRICIAN CHECK YOUR A.C. RECEPTACLE TO BE SURE THE GROUND IS FUNCTIONING PROPERLY.

THIS GAME IS DESIGNED TO DISSIPATE STATIC ELECTRICITY THROUGH THE GROUNDING PLANE OF THE GAME. IF THE A.C. GROUND DOES NOT WORK, THE GAME COULD DISCHARGE STATIC ELECTRICITY THROUGH THE GAME CIRCUITRY, WHICH COULD CAUSE DAMAGE.

THE POWER SUPPLY IS NOT VOLTAGE ADJUSTABLE. TO OPERATE THE GAME AT VOLTAGES OTHER THAN THOSE IT WAS DESIGNED FOR. PLEASE CONTACT OUR SERVICE DEPARTMENT FOR VOLTAGE CONVERSION INFORMATION.

WARNING

DO NOT remove any of the components on the main board (e.g. compact flash and eproms) while the game is powered on. This may cause permanent damage to the parts and the main board. Removing any main board component part while powered on will void the warranty.

ALWAYS REMOVE POWER TO THE GAME, BEFORE ATTEMPTING ANY SERVICE, UNLESS NEEDED FOR SPECIFIC TESTING. FAILURE TO OBSERVE THIS PRECAUTION COULD RESULT IN SERIOUS INJURY TO YOURSELF OR OTHERS.

THIS GAME IS NOT SUITABLE FOR INSTALLATION IN AN AREA WHERE A WATER JET COULD BE USED.

This appliance is not intended for use by persons (including children) with reduced physical, sensory or mental capabilities, or lack of experience and knowledge, unless they have been given supervision or instruction concerning use of the appliance by a person responsible for their safety. Children should be supervised to ensure that they do not play with the appliance

The game requires 6 amps of AC power from your AC outlet.

INSTRUCTIONS

1) With Joystick Use Your SKILL
to Aim for Candy TARGET



2) Press Button to Drop Vacuum



Vacuum Must Land INSIDE
Center of Target to WIN

YOU WIN!

YOU LOSE

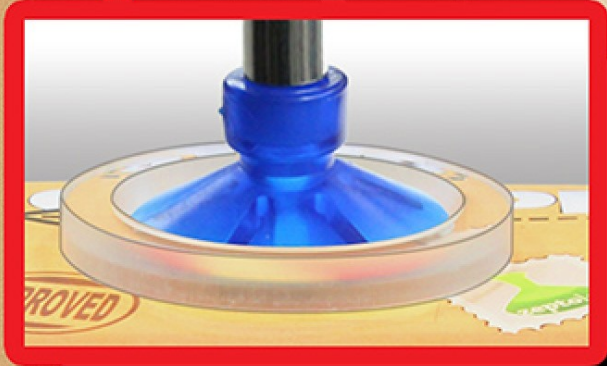

Setup / Configuration

In order to setup your game you will need to access the main PCB board. Open the large front door shown below. On the left wall you will find the main PCB circuit board. Located on the main PCB circuit board are the volume control, earphone jack, program/test buttons, and dipswitches. The dipswitches set the type of tilt it will use, enable or disable the play to you win feature, enter test modes, and disable the attract audio.

The switch labeled “Coin/Sw” will credit the machine without advancing the Coin Meter. The “MODE”, “UP”, and “DOWN” buttons are used when in test mode.

The dipswitch settings can be found on the next page.

To adjust the volume control, turn the knob to increase or decrease the volume levels.

The “CLR” button clears credits.

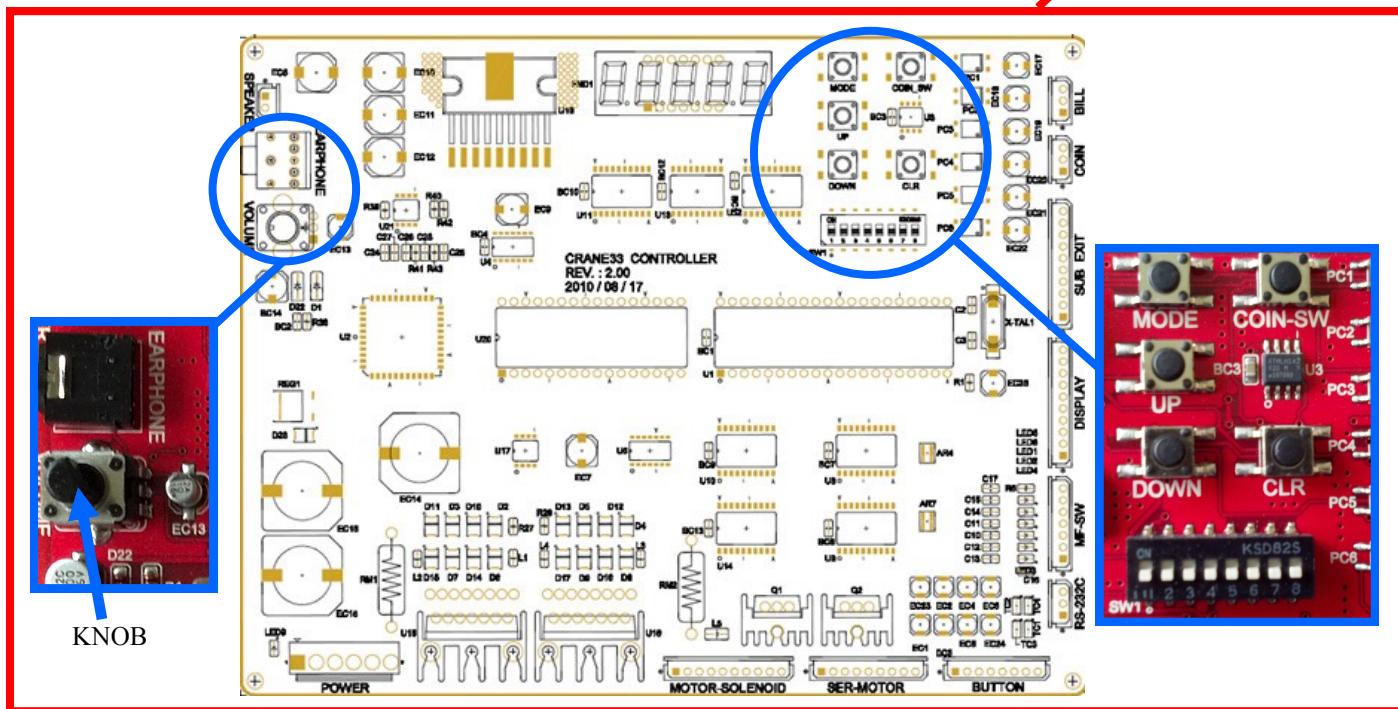
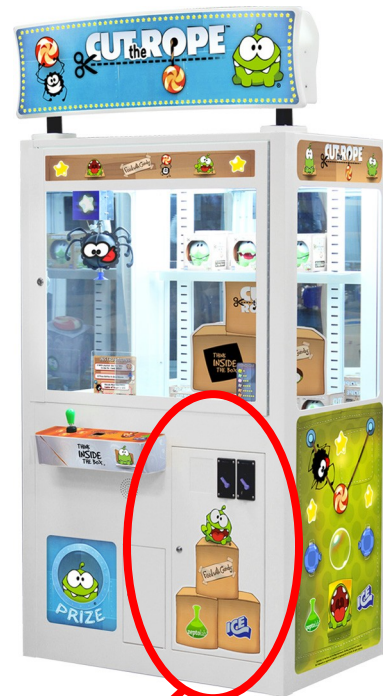

The Mode button found on the main board will allow you to setup your cost of play and also allow you to adjust how far the spider will descend into the prize chute when a prize is won. See the section on Mode options.

DIP Switch Settings								Function
SW 1	SW 2	SW 3	SW 4	SW 5	SW 6	SW 7	SW 8	
Off	Off	Off	Off					MUST ALL BE IN THE OFF POSITION
								MUST ALL BE IN THE OFF POSITION
				Off				Tilt Off; Game will sound alarm and reset. Game will still function.
				on				Tilt On; Game will display E7 and no longer work. Game must be reset by pressing the service button. Game will remain out of order until the service button is pressed.
					Off			Test Mode
					On			Cycles through all game functions.
						Off		Attract Sound Off
						On		Attract Sound On Every 30 seconds
							Off	Play till you win, disabled. 1 credit = 1 game
							On	Play till you win, enabled. Game will continue to give a credit and allow the player to play until a prize has been seen by the prize sensor.

Dip Switch Description and notes:

- Dipswitch 5 is for the Tilt Setting.

- With the Dipswitch in the off position : When the game is tilted a loud beep sound will occur, the game will stop temporarily and in 5 seconds the game will resume normal operation.
- With the Dipswitch in the on position: When the game is tilted a loud beep sound will occur for 5 seconds and the game will stop working. The game will not work again until the service button is pressed to reset this error.

MODE Options

With the game not in play, press the “MODE” button on the main board. The screen will display the software version on the main board’s display. Press the “MODE” button again to enter the first mode option. Use the “UP” and “DOWN” button located below the “MODE” button to change the value. The first part of the screen identifies which mode you are in and the numbers following the dashes is its current value. Press the “MODE” button to advance to the next mode. When all modes have been configured, pressing the “MODE” button will return you to game mode.



If you change your version of the software you will need to do a memory clear. To perform a memory clear, press and hold the clear button located on the main board. While this button is pressed, turn the game off by pressing the power rocket button.

Wait at least 2 seconds while still holding the clear button and turn the game back on. Keep holding the clear button for another 2 seconds. The memory will now be cleared.

BL - XX : This mode sets how many pulses your bill acceptor needs to send to start a game. Be sure to set the bill acceptor to one pulse only. A setting of 01 means 1 pulse = 1 game credit. A setting of 02 means 2 pulses = 1 game credit. A setting of 00 disables the dollar bill acceptor.

CO - XX: This mode sets how many pulses from the coin acceptors are needed to start a game. A setting of 01 means 1 pulse or .25 cents. A setting of 02 means 2 pulses or .50 cents. A maximum of \$10 can be set.

BP - XX: This setting determines how many games the player would need to purchase before pressing start to receive a free game. A value of 0 disables this option. For example, a value of 2 will mean that when the player puts 2 games worth of money into the machine without pressing start they would receive one free game for a total of 3 games.

TO - XX: This option allows you to adjust the game time. You can set this up to 99 seconds or if you set it to 0, the player will have infinite time to play.

LO - XX: This mode allows you to set how far the vacuum assembly will lower into the prize chute when a prize is released into it. This feature is to minimize damages to the product. A setting of 10 will lower the vacuum assembly by releasing 10 cm of rope. A setting of 99 will lower the vacuum assembly by releasing 90 cm of rope.

Setup - How to determine your cost of Prizes.

Cut the Rope is a pure SKILL game!

There are 6 distinct discs available that are to be adhered to prizes, using 3M double sided tape. Each disc is labeled and color coded, making it easier to distinguish from EASIER to MORE DIFFICULT.

ICE suggests using no more than 12 prizes on the playfield at any time.

The “estimated win ratio” noted in the guide below was based on extensive testing, but can vary depending on the skill of the player.

Your actual Payout Percentage will vary based on 4 factors: Cost of game, Cost of Prize, Difficulty level of disc, and the Skill of the player.

Example:

- If the cost of your chosen prize is \$5, and you use the E (green and yellow) disc, assuming a \$1 per game cost, we estimate a prize will be won every 25 games. This would equal a 20% payout (\$5 prize/\$25 in game play).
- If the cost of your chosen prize is \$25, and you use the C (orange and yellow) disc, assuming a \$1 per game cost, we estimate a prize will be won every 75 games. This would equal a 33% payout (\$25 prize/\$75 in game play).
- If the cost of your chosen prize is \$100, and you use the A (red and yellow) disc, assuming a \$.50 per game cost, we estimate a prize will be won every 500 games. This would equal a 40% payout (\$100 prize/\$250 in game play).

To Determine Your Prize Values, please use the following guide:



For A use 500 x CPP x DPP = Maximum Cost of Prize.
 For Y use 250 x CPP x DPP = Maximum Cost of Prize.
 For B use 100 x CPP x DPP = Maximum Cost of Prize.
 For C use 75 x CPP x DPP = Maximum Cost of Prize.
 For D use 50 x CPP x DPP = Maximum Cost of Prize.
 For E use 25 x CPP x DPP = Maximum Cost of Prize.

Estimated Payout Guide.

Target Value (puck)	A	Y	B	C	D	E
Prize Value Range	Hard	←————→				Easy
Estimated Win Ratio	1 in 500	1 in 250	1 in 100	1 in 75	1 in 50	1 in 25

TROUBLE SHOOTING

Power supply

The power supply is a ICE part number UC2010.

Yellow wires are +12 volts of DC.

Red wires are +5 volts of DC.

Black wires are grounds.

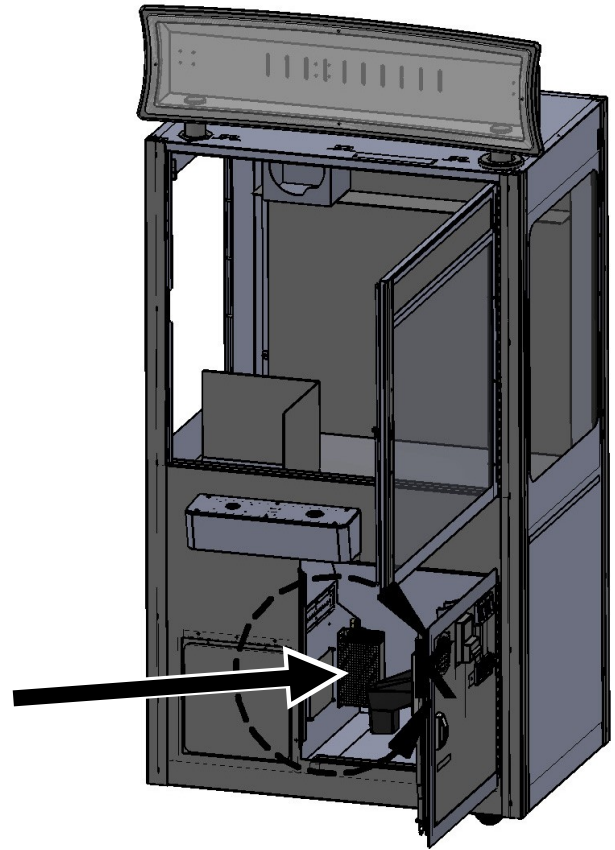
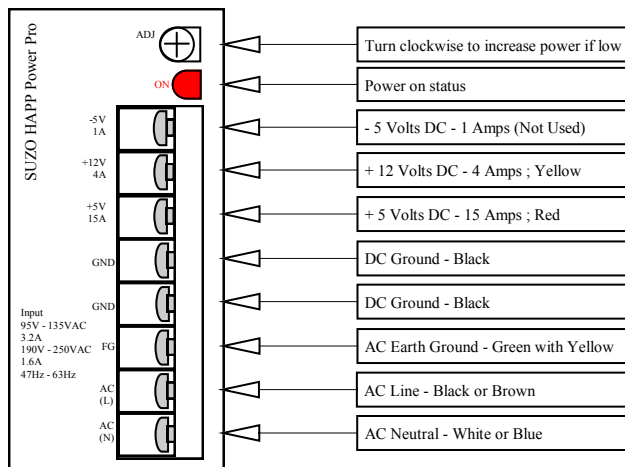

Checking DC Voltages

Volt test with the volt meter set to DC voltage. The +5 output can be adjusted by turning the adjustment screw of the power supply. Adjust to as close to +5 as possible. Increasing the +5 will also increase the +12. The voltage range can be plus or minus 5%.

Positive Probe:
Connect to +12V on power supply
(orange wire to power supply)

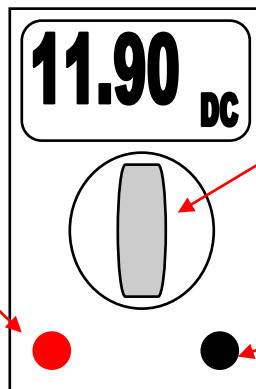

Turn to DC voltage check

Ground Probe:
Connect to GND on power supply
(Black wire to power supply)

Trouble Shoot: Error Codes

When either a switch is not seen or a motor doesn't work the crane will display a error code telling you what error it has encountered. Refer to the chart below for description of those error codes and suggestions to resolve them.

Error	Code Number displayed
HOME –Switch	E1 ; Check switch.
BACK—Switch	E2 ; Check switch.
LEFT—Switch	E3 ; Check switch.
RIGHT– Switch	E4 ; Check switch.
Up– Switch	E5 ; Check switch.
DOWN-Switch	E6 ; Check switch.
TILT ERROR ; See dip settings.	E7 ; Cycle power to clear!
HOME,BACK—Motor	EA ; Check motor. See below.
LEFT, RIGHT—Motor	EB; Check motor. See below.
UP, DOWN—Motor	EC ; Check motor. See below.

Problem	Check	Solution
Error EA, or EB error	Check U15, pins 4 & 9 for +12 VDC, check RM1 Check U15, pins 2/3, 13/14 for outputs. Check U15, pins 1 &15 Check L1, L2 Check U17	Replace RM1, U15, L1,L2, U17.
** IF U15 BAD **	Check D11, D3, D10, D2, D15, D7, D14, and D16.	Replace defective diodes.
Error EC	Check U16, pins 4 & 9 for +12VDC, check RM2 Check U16, pin 1 Check L3 Check U17	Replace RM2, U16, L3.U17.
Coin or Prize meter non-working	Check U16, pins 4 & 9 for +12VDC, check RM2 Check U16, pins 3 & 4 for meter pulses Check U16, pin 15 Check L4 Check U17	Replace RM2, U16, L4, U17.
** IF U16 BAD **	Check D13,D5,D12,D4,D17,D9,D17, and D8	Replace defective diodes.
No Vacuum control	Check Q1, D19.	Replace Q1, D19.
Prize door doesn't open	Check Q2, D20 and D21	Replace Q2, D20, D21.
No Audio	Check U19 and U21.	Replace U19, U21.
No Display	Check U5 (ULN2003)	Replace U5
No inputs	Check PC1 - PC6 (PC817)	Replace PC1 - PC6.
No +12	Power supply, Reg1 (7812)	Replace power supply, Reg1.

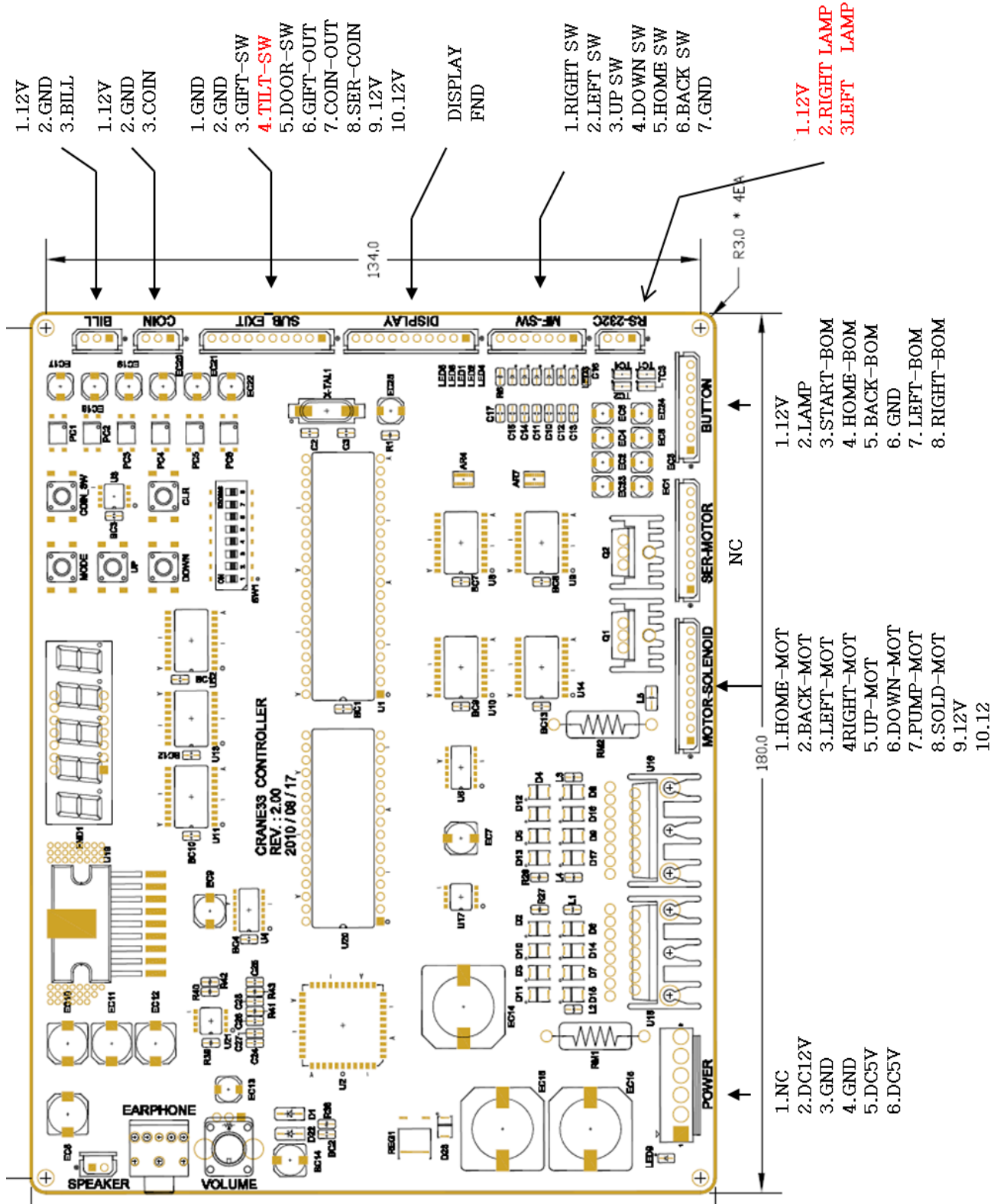

1) D/C POWER LINE

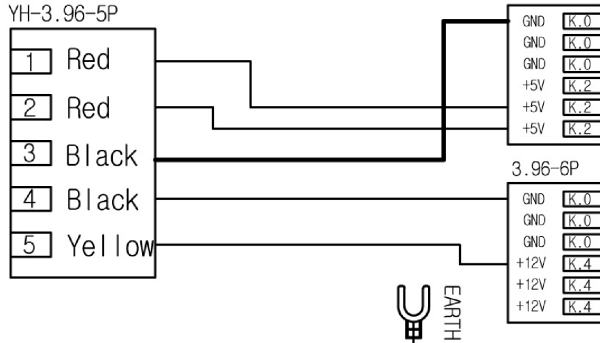

2) A/C CODE & DC POWER LINE

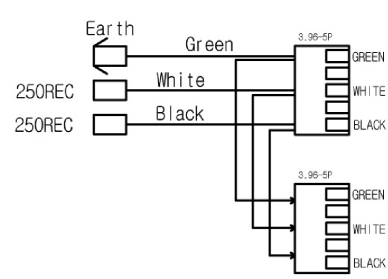

3) A/C POWER ON/OFF LINE

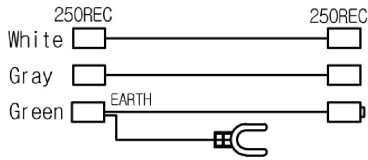

4) PLATEAU POWER LINE

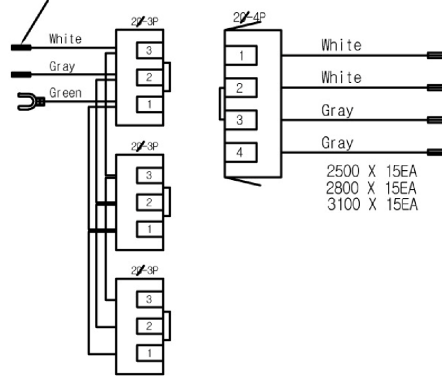

Joystick & Button

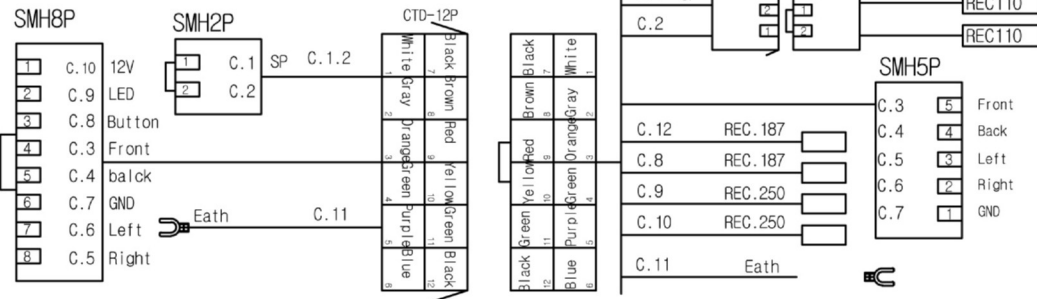

1) FND

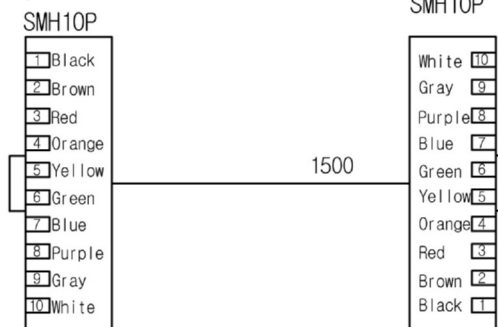

1) Gift Sensor

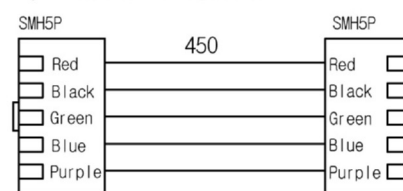

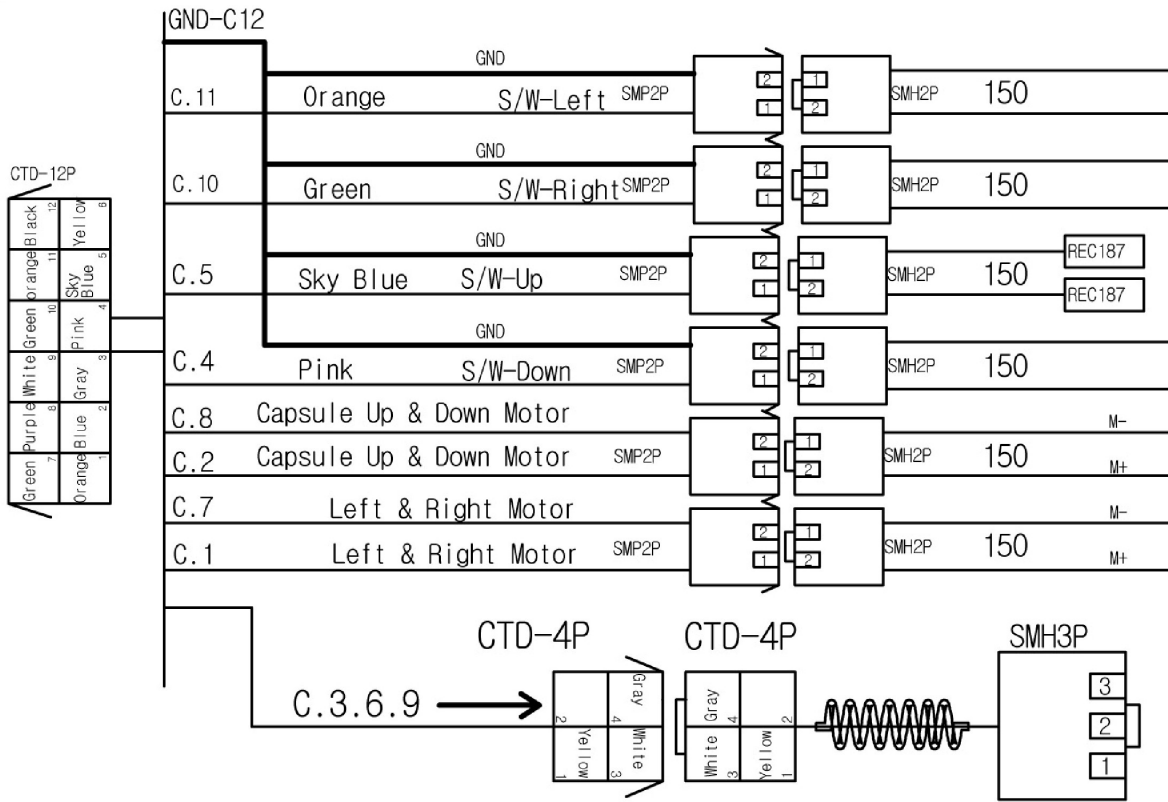

1) Coin, Bill

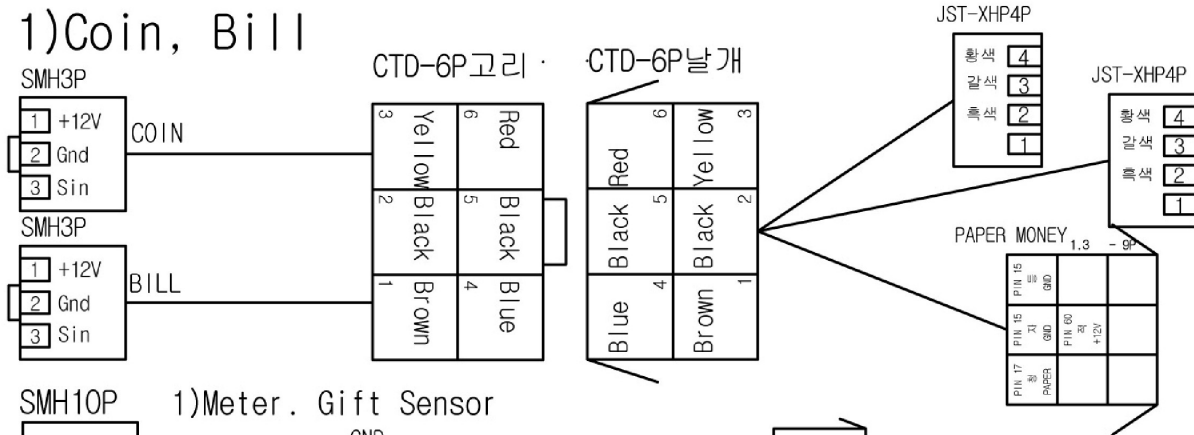

1) Meter. Gift Sensor

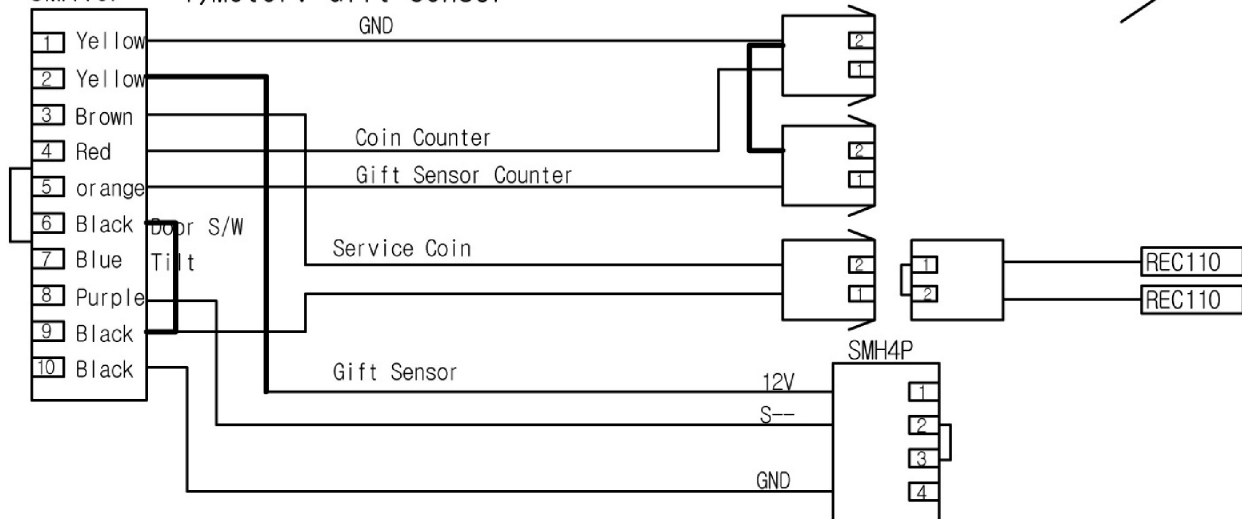

SMH10P

1	M-	Brown	Bakc & front	C.11
2	M+	Red	Bakc & front	C.1
3	M-	Orange	Left & Right	C.12
4	M+	Green	Left & Right	C.2
5	M-	Blue	Capsule Up & Down	C.13
6	M+	Purple	Capsule Up & Down	C.3
7	Breathe in	Gray		C.14
8	Valve	White		C.4
9	12V	Yellow		C.8
10	12V	Yellow		C.18

SMH7P

1	GND	Black	C.9
2	S/W-Back	Brown	C.17
3	S/W-Front	Red	C.7
4	S/W-Left	Orange	C.16
5	S/W-Right	Green	C.6
6	S/W-Up	Blue Sky	C.15
7	S/W-Down	Pink	C.5

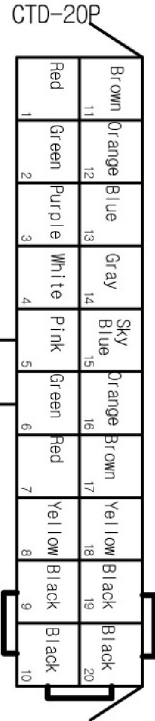

CTD-20P

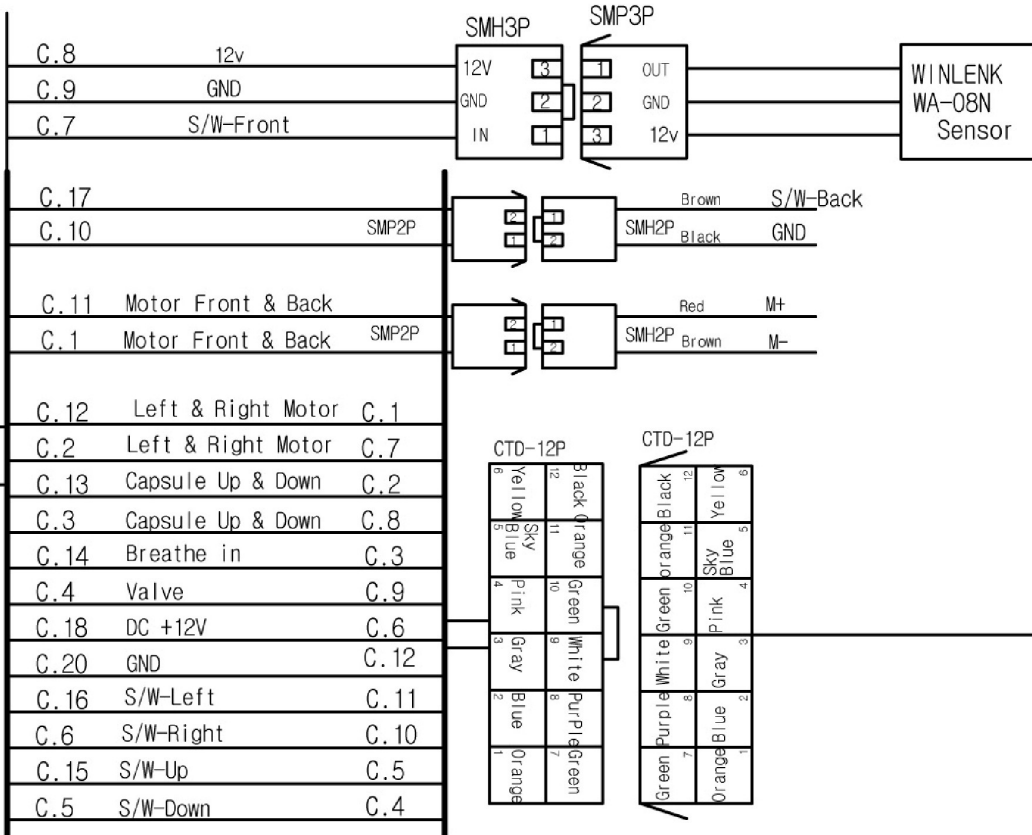
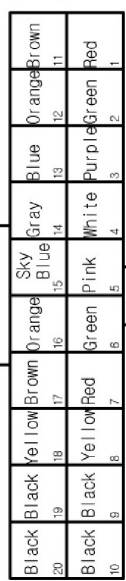

Tilt Adjustment

Level the game before setting the tilt bobbin and before you power on the crane. If you enable the tilt option it is important that the tilt bobbin is adjusted properly. Adjust the tilt bob so that there is between 1/16" to 1/8" is present all around. Loosen the wing nut, adjust the bobbin up or down and then tighten the wing nut.

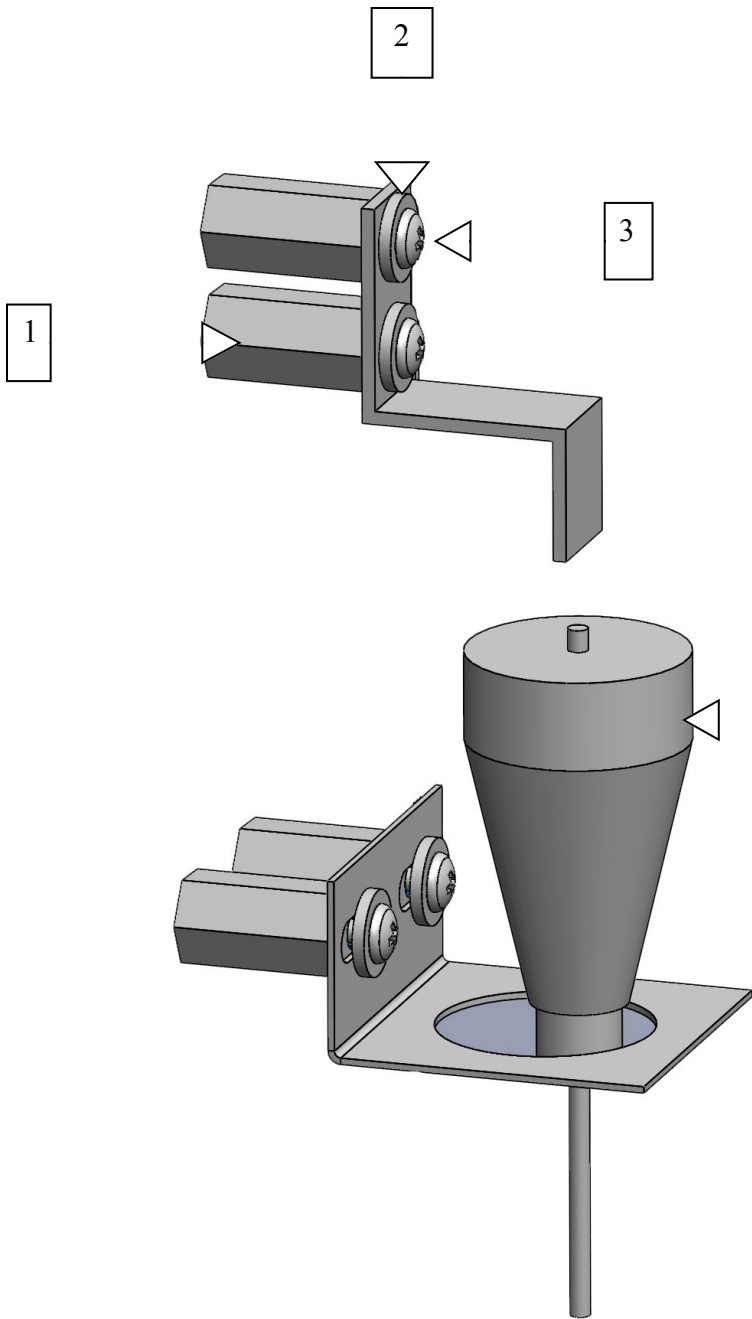

KEY:

- 1 - 6316 4x 6-32 x 3/4 x 3/8 HH Spacer
- 2 - 6158 4x #6 flat washer
- 3 - 641 4x 6-32 x 1/4 machine screw
- 4 - P1051 (tilt bob)

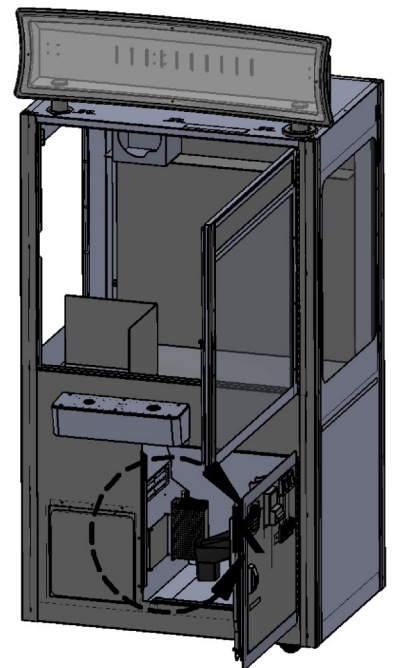

Replacing Cabinet and Door Glass

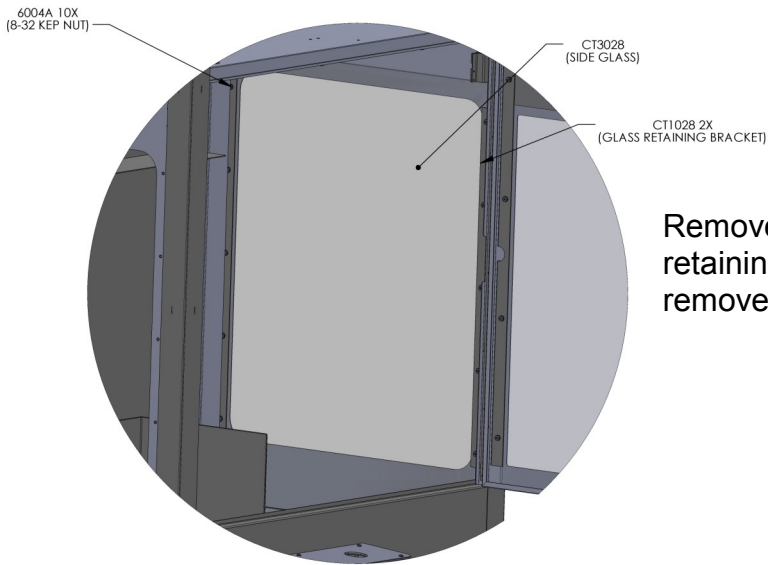

Remove the 10 8-32 Kep nuts that hold the glass retaining bracket to the cabinet. The glass can be removed. Reassembly in reverse order.

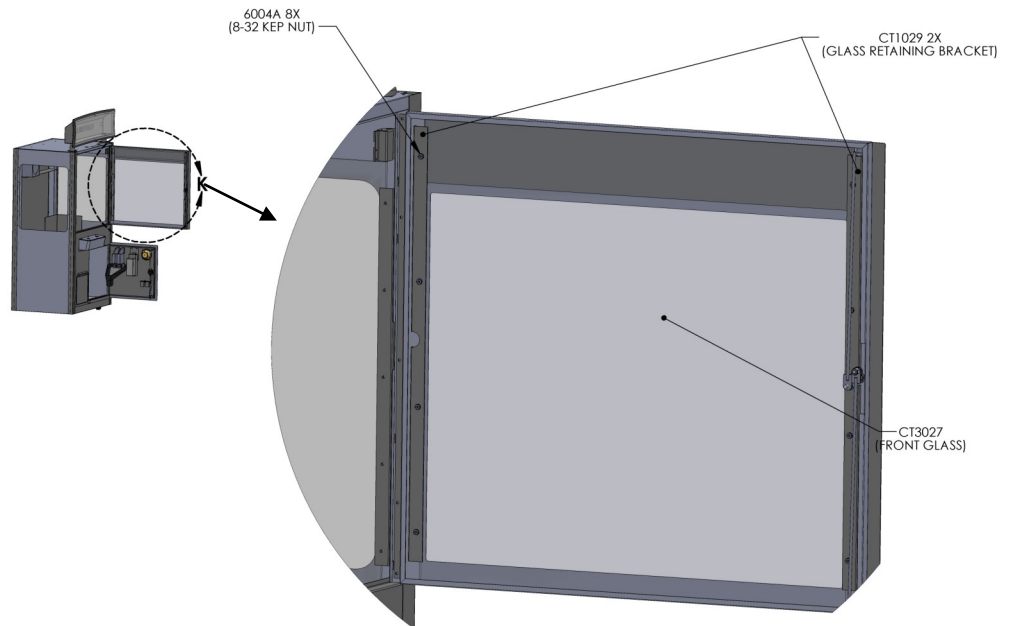
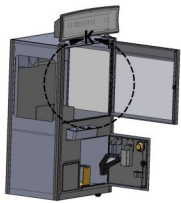

Remove the 8 8-32 Kep nuts that hold the glass retaining bracket to the door. The glass can be removed. Reassembly in reverse order.

Spider

- CT3010X Complete Assembly of Spider
- CT3006 Spider Fringe
- CT4001 Spider Legs (6 per game)
- CT3010A Suction Cup Nipple (white)
- CT3010B Pump (green)
- CT3010C Valve (yellow)
- CT3010D Cable Retractable (white)
- CT3010E Spider Body Spine
- CT3010F Spider Body Shell w/ Leg holes
- CT3010G Spider Shell no holes
- CT3010H Threaded Metal Tube (Vacuum side)
- CT3010J Threaded Metal Tube (Rope side)

Wagon

- CT1055X Wagon Assembly
- CT1053 Brass Gear (wagon)
- CT3031 Drive Wheel (wagon)
- CT2009 Motor (up/down for rope)

Carriage

- CT1061 (Crane) Unmodified
- CT2008 Motor used in wagon and carriage
- CT3030 Drive Wheels (carriage)
- CT4002 Rubber Grommet (black) used for drive wheels on wagon and carriage
- CT4003 Rubber Drive Belt (red)
- CT3032 Worm Drive Gear (wagon and carriage)
- CT1052 Brass Gear (carriage)

Electronics

- CT8422 Microswitch
- CT2004 Joystick
- CT2005 Button with Switch
- CT2032 Display pcba
- CT2034 Main board
- CT2039R Receiver Prize Sensor
- CT2039T Transmitter Prize Sensor
- 2133CTL Controller for chasing rope light

Graphics

PART#	DESCRIPTION	#PER GAME
CT3000	Control Panel Display Filter	1
CT7000	Cabinet Side	2
CT7001	Prize Door	1
CT7002	Cabinet Front	1
CT7003	Candy Chart	1
CT7004	Instructions	1
CT7005	Spider Eyes	1
CT7006	Button Decal	1
CT7007	Mirror	1
CT7008	Motor Cover	2
CT7011	Control Panel Front	1
CT7012	Control Panel	1
CT7026	Side marquee	2
CT7027	Upper Marquee	1
CT7028	Front/LowerMarquee	1
CT7040	Programming Buttons	1
CT7031	"Harnessing ""Button"""	1
CT7032	"Harnessing ""Bill"""	1
CT7033	"Harnessing ""Coin"""	1
CT7034	"Harnessing ""Speaker"""	1
CT7035	"Harnessing ""Motor-Solenoid"""	1
CT7036	"Harnessing ""MF-SW"""	1
CT7037	"Harnessing ""Display"""	1
CT7038	"Harnessing ""Sub_Exit"""	1
CT7039	"Harnessing ""Main Board Power"""	1
CT7041	Kit - T-shirt Decal	6
CT7041	Kit - Cut the Rope logo	6



WARRANTY POLICY

I.C.E. Inc warrants all components in new machines to be free of defects in materials and workmanship for the period listed below:

- 180 days on Main PCB's, Computers & Motors
- 1 year on all LCD monitor panels
- 90 days on all other electronic and mechanical components
- 30 days on all I.C.E. repairs and parts purchases

I.C.E. Inc shall not be obligated to furnish a warranty request under the following conditions:

- Equipment or parts have failed through normal wear and tear
- Equipment has been subjected to unwarranted stress, abuse or neglect
- Equipment has been damaged as a result of arbitrary repair/modification

Products will only be covered under warranty by obtaining an I.C.E. authorized RMA #. To obtain an RMA # please provide I.C.E. tech support with the game serial # or original I.C.E. invoice # and a detailed description of the failure or fault symptoms.

I.C.E. Inc will assume no liability whatsoever for costs associated with labor or travel time to replace defective parts. All defective warranty covered components will be replaced with new or factory refurbished components equal to OEM specifications.

I.C.E. Inc will cover domestic UPS ground, or comparable shipping costs during the warranty period. International or expedited shipments are available for an additional charge. To obtain credit defective parts must be returned to I.C.E. Inc, at the customer's expense, within 30 days. After 30 days a 15% re-stocking fee will apply to all returns.

ICE distributors are independent, privately owned and operated. In their judgment, they may sell parts and/or accessories other than those manufactured by I.C.E. Inc. We cannot be responsible for the quality, suitability or safety of any non-I.C.E. part or modification (including labor) that is performed by such a distributor.

Innovative Concepts in Entertainment
10123 Main St.
Clarence, NY 14031
Phone #: (716) - 759 - 0360
Fax #: (716) - 759 - 0884
www.icegame.com