

1<sup>st</sup> PRINTING

SEGA<sup>®</sup>

Sega Amusements Europe Limited.  
42 Barwell Business Park, Leatherhead Road, Chessington, Surrey, KT9 2NY, United Kingdom.  
Telephone: +44 (0) 208 391 8090 Facsimile: +44 (0) 208 391 8099  
email: mailbox@sega.co.uk Web: <http://www.segaarcade.com>

Sega Corporation  
Canal Side Bldg 1-39-9 Higashishinagawa Shinagawa-ku, Tokyo, 140-8583, Japan.  
Telephone: +81-3-687-7133 Facsimile: +81-3-687-7134

© SEGA

DREAM RAIDERS

OWNER'S MANUAL

420-0016UK

SEGA<sup>®</sup>

OWNER'S MANUAL

Dream  Raiders<sup>™</sup>



#### IMPORTANT

- Before using this product, read this manual carefully to understand the contents herein stated.
- After reading this manual, be sure to keep it near the product or in a convenient place for easy reference when necessary.

## BEFORE USING THE PRODUCT, BE SURE TO READ THE FOLLOWING:

### To maintain safety:

To ensure the safe operation of this product, be sure to read the following before usage.

The following instructions are intended for the users, operators and the personnel in charge of the operation of the product. After carefully reading and sufficiently understanding the warning displays and cautions, handle the product appropriately. Be sure to keep this manual close to the product or in a convenient place for future reference.

Herein, explanations which require special attention are enclosed with dual lines. Depending on the potentially hazardous degrees, the terms of DANGER, WARNING, CAUTION, etc. are used. Be sure to understand the contents of the displays before reading the text.

 **DANGER** Indicates that mishandling the product by disregarding this pictograph will cause severe injury or death.

 **WARNING** Indicates that mishandling the product by disregarding this warning will cause a potentially hazardous situation which can result in death or serious injury.

 **CAUTION** Indicates that mishandling the product by disregarding this caution will cause a slight hazardous situation which can result in personal injury and/or material damage.

### For the safe usage of the product, the following pictographs are used:

 Indicates "HANDLE WITH CARE." In order to protect the human body and equipment, this display is attached to places where the Owner's Manual, Serviceman Manual and/or Service Manual should be referred to.

- **Perform work in accordance with the instructions herein stated.** Instructions for work are explained by paying attention to the aspect of accident prevention. Failing to perform work as per the instructions can cause accidents. In the case where only those who have technical expertise should perform the work to avoid hazardous situation, the instructions herein state that the site maintenance personnel should perform such work.
- **Be sure to turn off the power before working on the machine.** To prevent an electric shock, be sure to turn off the power before carrying out any work that requires direct contact with the interior of the product. If the work is to be performed in the power-on status, the Instruction Manual herein always states to that effect.
- **Be sure to ground the Earth Terminal.** (This is not required in the case where a power cord with earth is used.)
- **This product is equipped with the Earth Terminal.** When installing the product, connect the Earth Terminal to the "accurately grounded indoor earth terminal" by using an earth wire. Unless the product is grounded appropriately, the user can be subject to an electric shock. After performing repair, etc. for the control equipment, ensure that the Earth Wire is firmly connected to the control equipment.
- **Ensure that the Power Supply used is equipped with an Earth Leakage Breaker.** This product does not incorporate the Earth Leakage Breaker. Using a power supply which is not equipped with the Earth Leakage Breaker can cause a fire when earth leakage occurs.
- **Be sure to use fuses which meet the specified rating.** (Only for the machines which use fuses.) Using fuses exceeding the specified rating can cause a fire and an electric shock. (Only for the machines which use fuses.) Using fuses exceeding the specified rating can cause a fire and an electric shock.

- **Specification changes (removal of equipment, conversion and addition) not designated by SEGA are not allowed.** The parts of the product include warning labels for safety, covers for personal protection, etc. It is very hazardous to operate the product by removing parts and/or modifying the circuits. Should doors, lids and protective parts be damaged or lost, refrain from operating the product, and contact where the product was purchased from or the office herein stated. SEGA shall not be held responsible for any accidents, compensation for damage to a third party, resulting from the specifications not designated by SEGA.
- Ensure that the product meets the requirements of appropriate electrical specifications. Before installing the product, check for electrical specifications. SEGA products have a nameplate on which electrical specifications are described. Ensure that the product is compatible with the power supply voltage and frequency requirements of the location. Using any electrical specifications different from the designated specifications can cause a fire and an electric shock.
- Install and operate the product in places where appropriate lighting is available, allowing warning labels to be clearly read. To ensure safety for the customers, labels and printed instructions describing potentially hazardous situations are applied to places where accidents can be caused. Ensure that where the product is operated has sufficient lighting allowing the warnings to be read. If any label is peeled off, apply it again immediately. Please place an order with where the product was purchased from or the office herein stated.
- When handling the monitor, be very careful. (Applies only to products with monitors.) Some of the monitor parts are subject to high tension voltage. Even after turning off the power, some portions are still subject to high tension voltage sometimes. Monitor repair and replacement should be performed only by those technical personnel who have knowledge of electricity and technical expertise.
- Be sure to adjust the monitor properly. (Applies only to products with monitors.) Do not operate the product leaving on-screen flickering or blurring as it is. Using the product with the monitor not properly adjusted may cause dizziness or a headache to an operator, a player, or the customers.
- When transporting or reselling this product, be sure to attach this manual to the product.
- *In the case where commercially available monitors and printers are used in this product, only the contents relating to this product are explained herein. Some commercially available equipment has functions and reactions not stated in this manual. Read this manual together with the specific instruction manual of such equipment.*
- *Descriptions herein contained may be subject to improvement changes without notice.*
- *The contents described herein are fully prepared with due care. However, should any question arise or errors be found, please contact SEGA.*

## INSPECTIONS IMMEDIATELY AFTER TRANSPORTING THE PRODUCT TO THE LOCATION

Normally, at the time of shipment, SEGA products are in a status allowing for usage immediately after transporting to the location. Nevertheless, an irregular situation may occur during transportation. Before turning on the power, check the following points to ensure that the product has been transported in a satisfactory status.

- Are there any dented portions or defects (cuts, etc.) on the external surfaces of the cabinet?
- Are casters and adjusters damaged?
- Do the power supply voltage and frequency requirements meet with those of the location?
- Are all wiring connectors correctly and securely connected? Unless connected in the correct way, connector connections can not be made accurately. Do not insert connectors forcibly.
- Do power cables have cuts and dents?
- Are all accessories available?
- Can all doors and lids be opened with the accessory keys? Can doors and lids be firmly closed?

# TABLE OF CONTENTS

<b>INTRODUCTION</b>	<b>vi</b>
<b>1 HANDLING PRECAUTIONS</b>	<b>1</b>
<b>2 PRECAUTIONS REGARDING INSTALLATION LOCATION</b>	<b>5</b>
2-1 LIMITATIONS OF USAGE	6
2-2 OPERATION AREA	7
<b>3 PRECAUTIONS REGARDING PRODUCT OPERATION</b>	<b>9</b>
3-1 BEFORE OPERATION	9
3-2 DURING OPERATION (PAYING ATTENTION TO CUSTOMERS)	12
<b>4 PART DESCRIPTIONS</b>	<b>15</b>
<b>5 ACCESSORIES</b>	<b>16</b>
<b>6 ASSEMBLY AND INSTALLATION</b>	<b>18</b>
6-1 CONNECTING FRONT AND REAR CABINETS	21
6-2 INSTALLING THE FLOOR	24
6-3 INSTALLING THE BILLBOARD	26
6-4 FIXATION TO SITE	28
6-5 POWER SUPPLY AND OTHER CONNECTIONS	30
6-6 TURNING ON THE POWER	31
6-7 CONFIRMATION OF ASSEMBLY	33
6-8 APPLYING WARNING LABELS (EPILEPTIFORM SEIZURES)	34
<b>7 PRECAUTIONS WHEN MOVING THE MACHINE</b>	<b>35</b>
<b>8 GAME DESCRIPTION</b>	<b>39</b>
8-1 GAME OVERVIEW	39
8-2 BASIC CONTROLS AND FUNCTIONS	39
8-3 GAME SCREENS	40
8-4 LIFE GAUGE	41
8-5 PLAYER DAMAGE	42
8-6 STAGE SELECT SCREEN	43
8-7 RESULT SCREEN	44
8-8 TIER 2 STAGES	45



<b>9</b>	<b>EXPLANATION OF TEST AND DATA DISPLAY</b>	<b>46</b>
	9-1 SWITCH UNIT AND COIN METER.	47
	9-2 TEST MENU	47
	9-3 GAME TEST MODE	48
	9-4 BOOKKEEPING	49
	9-5 INPUT TEST	50
	9-6 OUTPUT TEST	51
	9-7 GAME ASSIGNMENTS	52
	9-8 SEAT MOTION TEST	54
	9-9 CONTROLLER ADJUSTMENT	55
	9-10 BACKUP DATA CLEAR	57
	9-11 TEST DEFAULT VALUES	58
<b>10</b>	<b>CONTROLLER UNIT(S), SWITCHES AND BUTTONS</b>	<b>59</b>
	10-1 ADJUSTING/REPLACING THE VOLUME POT	60
	10-3 GREASING	64
	10-4 START BUTTON ASSY	65
<b>11</b>	<b>GRAPHICS DISPLAY</b>	<b>66</b>
	11-1 SAFETY PRECAUTIONS WHEN HANDLING THE MONITOR	66
<b>12</b>	<b>COIN HANDLING</b>	<b>72</b>
	12-1 CLEANING THE COIN SELECTOR	72
	12-2 FAULT FINDING	75
	12-3 ADJUSTING THE PRICE OF PLAY (EXCEL)	76
	12-4 ADJUSTING THE PRICE OF PLAY (VTS)	77
<b>13</b>	<b>SEAT MECHANISM</b>	<b>81</b>
	13-1 PITCH VOLUME	82
	13-2 ROLL VOLUME	87
<b>14</b>	<b>PERIODIC INSPECTION</b>	<b>92</b>
<b>15</b>	<b>TROUBLESHOOTING</b>	<b>95</b>
	11-1 TROUBLESHOOTING (WHEN NO ERROR MESSAGE IS SHOWN)	95
<b>16</b>	<b>GAME BOARD (RINGWIDE)</b>	<b>98</b>
<b>17</b>	<b>DESIGN-RELATED PARTS</b>	<b>120</b>
<b>18</b>	<b>PARTS LIST</b>	<b>122</b>
<b>19</b>	<b>WIRE COLOUR CODE TABLE</b>	<b>152</b>
<b>20</b>	<b>WIRING DIAGRAMS</b>	<b>153</b>

# INTRODUCTION

This manual is intended to provide detailed descriptions together with all necessary information covering the general operation of electronic assemblies, electromechanical, servicing control, spare parts, etc. for the product, "DREAM RAIDERS"

This manual is intended for the owners, personnel managers in charge of operation of this product. Operate the product after carefully reading and sufficiently understanding the instructions.

In the unlikely event that the product does not function correctly, DO NOT allow anyone other than a technician to touch the internal system. Turn off the power to the machine, making sure to unplug the electrical cord from the outlet, and contact the office listed below or the point-of-purchase for this product.

Use of this product is unlikely to cause physical injuries or damage to property. However, points that require special attention are indicated by bold text, the words "STOP, IMPORTANT or CAUTION" and the symbols below.

## **IMPORTANT**

**Indicates important information that, if ignored, may result in the mishandling of the product and cause faulty operation or damage to the product.**

## **WARNING**    **CAUTION**

**Indicates a warning or caution that, if ignored, may result in the mishandling of the product and cause faulty operation or damage to the product.**

### Sega Amusements Europe Limited.

42 Barwell Business Park, Leatherhead Road, Chessington, Surrey, KT9 2NY. United Kingdom.

European Sales: +44 (0) 208 391 8090 Facsimile: +44 (0) 208 391 8099

STS (Spares): +44 (0) 208 391 8060 Facsimile: +44 (0) 208 391 8096

email: mailbox@sega.co.uk Web: <http://www.segaarcade.com>

### Sega Corporation

Canal Side Bldg 1-39-9 Higashishinagawa Shinagawa-ku, Tokyo, 140-8583, Japan.

Telephone: +81-3-687-7133 Facsimile: +81-3-687-7134

### Play It! Amusements, inc.

252 Beinoris Drive, Wood Dale, IL. 60191, USA

USA Sales: +00 (1) 224 265 4287

## SPECIFICATIONS

Machine Dimensions (Normal):	1,59m (62.6in.) [Width] x 2,05m (80.7in.) [Depth]
Machine Height:	2.2m (86.6in.) (Installed)
Machine Weight:	590kg (1300.7lb) Approx (Installed)
Rating:	AC253V@3.56A, AC240V@3.6A, AC230V@3.75A, AC220V@3.9A AC120V@7.4A, AC110V@7.5A

## Definition of 'Site Maintenance Personnel or Other Qualified Individuals

### **WARNING**

**Servicing and maintenance work of the contents herein stated should be performed by the SERVICEMAN stipulated as per IEC Standard. Those who do not have technical expertise and knowledge other than the SERVICEMAN are not allowed to perform the work herein stated. Executing aforementioned work by such non-technical personnel can cause serious accidents that may endanger life.**

Parts replacement, maintenance inspections and troubleshooting should be carried out by site maintenance personnel or other qualified professionals. This manual includes directions for potentially dangerous procedures which should only be carried out by professionals with the appropriate specialised knowledge.

The site maintenance personnel or other qualified professionals mentioned in this manual are defined as follows:

#### **Site maintenance personnel:**

Individuals with experience in maintaining amusement equipment, vending machines, etc., working under the supervision of the owner/operator of this product to maintain machines within amusement facilities or similar premises by carrying out everyday procedures such as assembly, maintenance inspections, and replacement of units/expendable parts.

#### **Activities to be carried out by site maintenance personnel:**

Amusement equipment/vending machine assembly, maintenance inspection and replacement of units/expendable parts.

#### **Other qualified professionals:**

Persons employed by amusement equipment manufacturers, or involved in design, production, testing or maintenance of amusement equipment. The individual should have either graduated from technical school or hold similar qualifications in electrical/electronics/mechanical engineering.

#### **Activities to be carried out by other qualified professionals:**

Amusement equipment/vending machine assembly, repair/adjustment of electrical/electronic/mechanical parts.

### Game Version Notation

Version numbers appearing in TEST MODE are displayed as asterisks. When describing software version upgrades, only major versions and minor version numbers are displayed. Release version numbers are for SEGA's administrative use only. If you require these numbers, please contact the office listed in this manual or the point-of-purchase for this product.

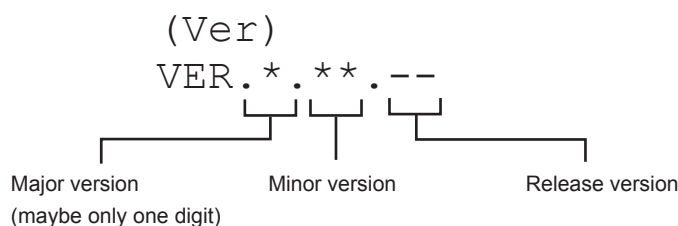

### Waste of Electrical and Electronic Equipment (WEEE) Statement.

The WEEE (Waste of Electrical and Electronic Equipment) directive places an obligation on all EU based manufacturers and importers of Electrical and Electronic Equipment to take back products at the end of their useful life. Sega Amusements Europe Ltd accepts its responsibility to finance the cost of treatment and recovery of redundant WEEE in the United Kingdom in accordance with the specified WEEE recycling requirements.

The symbol shown below will be on all products manufactured from 13th August 2005, which indicates this product must NOT be disposed of with other normal waste. Instead, it is the user's responsibility to dispose of their waste equipment by arranging to return it to a designated UK collection point for the correct recycling of waste electrical and electronic equipment.

For more information about where you can send your waste equipment for recycling contact your local authority office.

For non-UK users contact your local authority office for information on the recycling of Waste Electrical and Electronic Equipment.

### Battery Recycling Statement.

The EC Directive on Batteries and Accumulators (2006/66/EC) aims to minimise the impact of batteries on the environment and encourage the recovery of the materials they contain. To achieve increased collection and recycling of waste batteries, the Directive places 'producer responsibility' obligations on manufacturers and importers of portable, industrial and automotive batteries.

The symbol shown below will be on all equipment fitted with batteries from 26th September 2008 and indicates they must NOT be disposed of with other normal waste. Instead, it is the user's responsibility to dispose of used batteries by arranging to return them to a designated collection point for the correct recycling.

For more information about where you can send your waste batteries for recycling contact your local authority office.

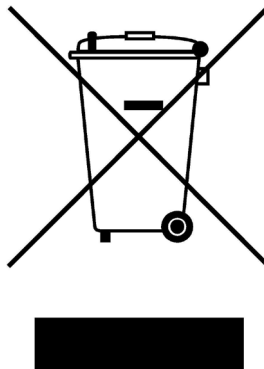

REGISTERED IN ENGLAND REGISTERED NO. 1711515

REGISTERED OFFICE: BLOCK C 42 BARWELL BUSINESS PARK, CHESSINGTON, SURREY KT9 2NY

# 1 HANDLING PRECAUTIONS

When installing or inspecting the machine, be very careful of the following points and pay attention to ensure that the player can enjoy the game safely.

Non-compliance with the following points or inappropriate handling running counter to the cautionary matters herein stated can cause personal injury or damage to the machine.

## WARNING

**Before performing work, be sure to turn the power off. Performing the work without turning the power off can cause an electric shock or short circuit. In cases where work should be performed in the status of power on, this manual always states to that effect.**

**To avoid an electric shock or short circuit, do not plug in or unplug quickly.**

**To avoid an electric shock, do not plug in or unplug with a wet hand.**

**Do not expose power cords or earth wires on the surface, (floor, passage, etc.) If exposed, the power cords and earth wires are susceptible to damage. Damaged cords and wires can cause an electric shock or short circuit.**

**To avoid causing a fire or an electric shock, do not put things on or damage the power cords.**

**When or after installing the product, do not unnecessarily pull the power cord. If damaged, the power cord can cause a fire or an electric shock.**

**In case the power cord is damaged, ask for a replacement through where the product was purchased from or the office herein stated. Using the cord as is damaged can cause fire, an electric shock or leakage.**

**This product MUST be Earthed. Inappropriate Earthing can cause an electric shock.**

**Be sure to use fuses meeting the specified rating. Using fuses exceeding the specified rating can cause a fire or an electric shock.**

**Be sure that connections such as IC BD are made properly. Insufficient insertion can cause an electric shock.**

**Specification changes, removal of equipment, conversion and/or addition, not designated by SEGA are not permitted.**

**Failure to observe this may cause a fire or an electric shock. Non-compliance with this instruction can have a bad influence upon physical conditions of the players or the onlookers, or result in injury during play.**

**SEGA shall not be held responsible for damage, compensation for damage to a third party, caused by specification changes not designated by SEGA.**

**Do not perform any work or change parts not listed in this manual. Doing so may lead to an accident.**

**If you need to perform any work not listed in this manual, request work from the office indicated in this manual or the point of purchase, or inquires for details.**

**Be sure to perform periodic maintenance inspections herein stated.**



## **STOP** IMPORTANT

**For the IC board circuit inspections, only the use of a logic tester is recommended. Using a Multi Tester or General Purpose Tester may result in damage to IC Circuits.**

**Static electricity from your body may damage some electronics devices on the IC board. Before handling the IC board, touch a grounded metallic surface so that the static electricity can be discharged.**

**Some parts are not designed and manufactured specifically for this game machine. The manufacturers may discontinue, or change the specifications of such general-purpose parts. If this is the case, SEGA cannot repair or replace a failed game machine whether or not a warranty period has expired.**

### **CONCERNING THE STICKER DISPLAY**

This SEGA product has stickers attached describing the product manufacture No. (Serial No.) and Electrical Specifications. It also has a Sticker describing where to contact for repair and for purchasing parts. When inquiring about or asking for repairs, mention the Serial No. and Name of Machine indicated on the Sticker. The Serial Number indicates the product register. Identical machines could have different parts depending on the date of production. Also, improvements and modifications might have been made after the publication of this manual. In order to ensure you order the correct parts, mention the Serial No. when contacting the applicable places.

### **CONCERNING WARNING DISPLAYS**

This SEGA product has warning displays on stickers, labels and/or printed instructions adhered/attached to or incorporated in the places where a potentially hazardous situation could arise. The warning displays are intended for accident prevention for customers and for avoiding hazardous situations relating to maintenance and servicing work. Some portions of the cabinet contain high voltage and may cause accidents if touched. When performing maintenance, be very careful of the warning displays. It is especially important that any complex repair and replacement work not mentioned herein should be performed by those technical personnel who have knowledge of electricity and technical expertise.

In order to prevent accidents, caution any customer ignoring the warnings to cease and desist immediately.

### **VIDEO GAME-INDUCED SEIZURES (VGS) AND PHOTONSENSITIVE EPILEPSY (PSE)**

This SEGA product has warning displays on stickers which outline the risk of epilepticform and photosensitive seizures. These warning displays on stickers are applied close in proximity of the device which may promote symptoms of either video game-induced seizures or epilepsy. The warning displays are supplied in several languages and form part of the Installation kit supplied with this product. It is standard practice for the English version of this label to be applied during manufacture, however it is especially important for the operator to apply the same said label in the language of the country of operation.

# STICKER DISPLAY

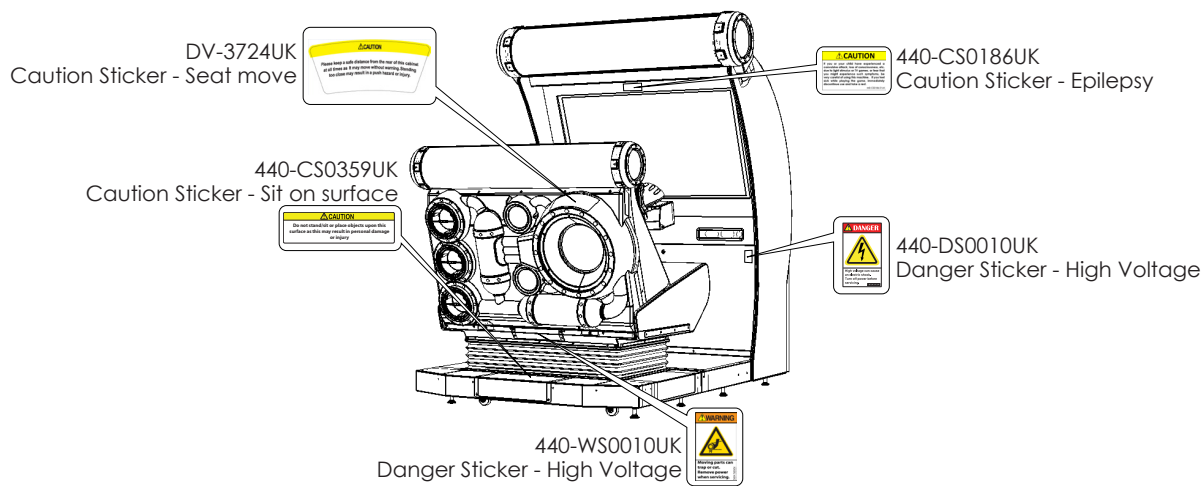
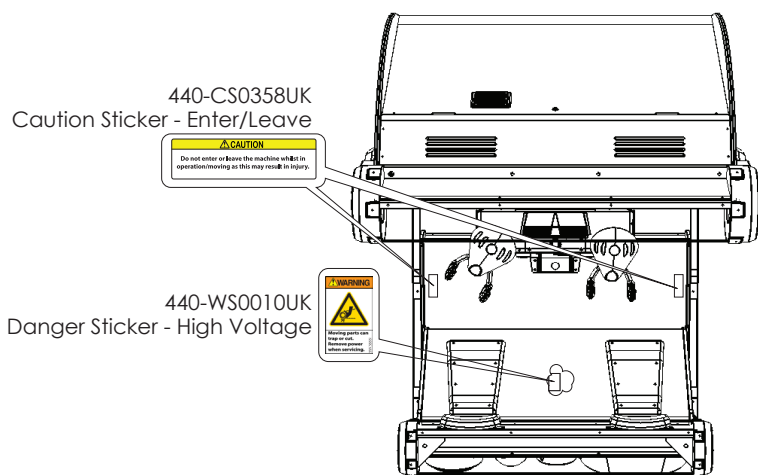
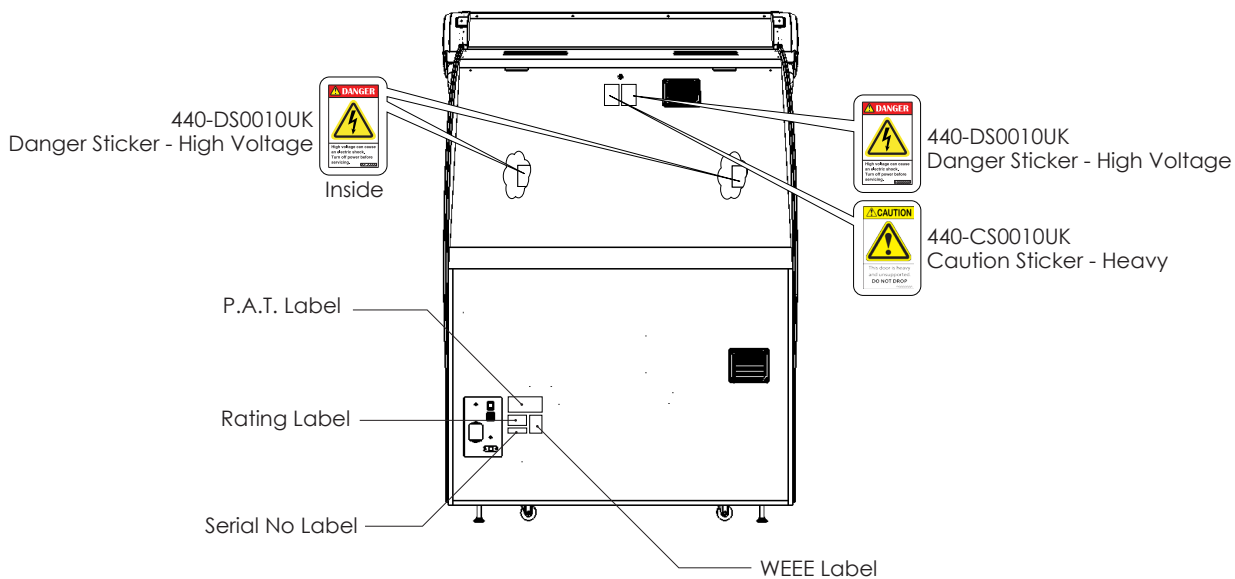

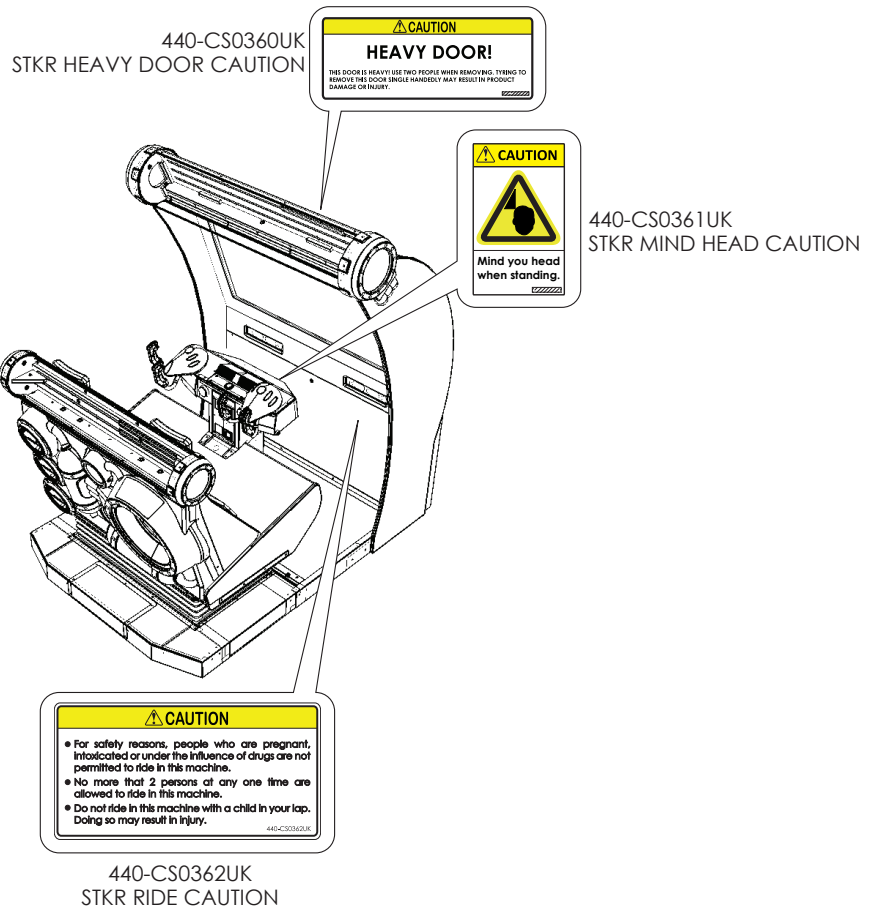
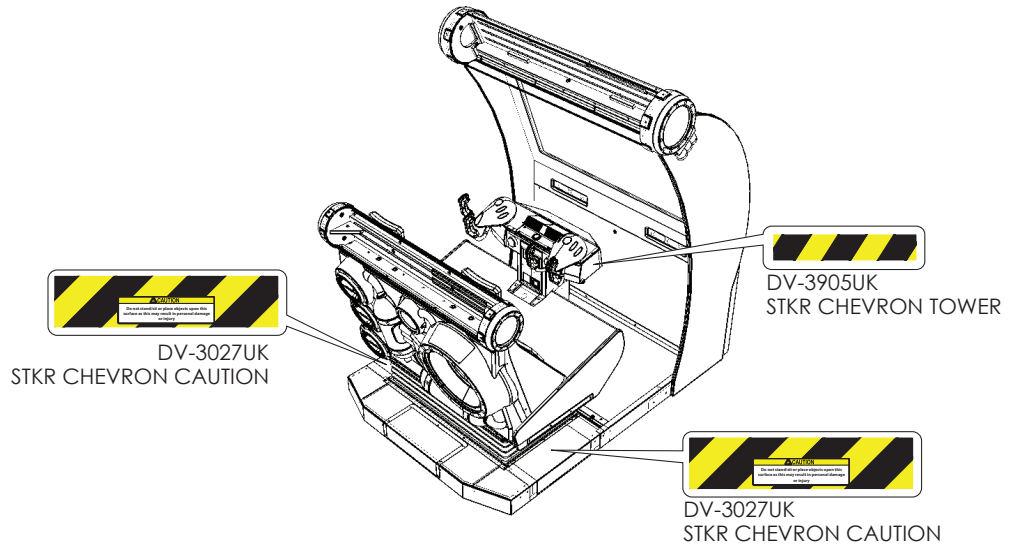

## 2 PRECAUTIONS REGARDING INSTALLATION LOCATION

### WARNING

This product is an indoor game machine. Do not install it outside. Even indoors, avoid installing in places mentioned below so as not to cause a fire, electric shock, injury and/or malfunction.

Places subject to rain or water leakage, or places subject to high humidity in the proximity of an indoor swimming pool and/or shower, etc.

Places subject to direct sunlight, or places subject to high temperatures in the proximity of heating units, etc.

Places filled with inflammable gas or vicinity of highly inflammable/volatile chemicals or hazardous matter.

Dusty places.

Sloped surfaces.

Places subject to any type of violent impact.

Vicinity of anti-disaster facilities such as fire exits and fire extinguishers.

Areas where the temperature exceeds the applicable temperature (ambient temperature) range of 5 to 30 degrees centigrade.

### STOP IMPORTANT

Securing a safe area for operation as described in this manual will ensure safe operation for players and observers.

SEGA shall not be held responsible for damage or compensation for damage to a third party, resulting from the failure to observe this instruction.

## 2-1 LIMITATIONS OF USAGE

### WARNING

Be sure to check the Electrical Specifications. Ensure that this product is compatible with the location's power supply, voltage, and frequency requirements. A label describing Electrical Specifications is attached to the product. Non-compliance with the Electrical Specifications can cause a fire and electric shock.

This product requires a breaker and earth mechanism as part of the location facilities. Using the product without these can cause a fire and electric shock.

Ensure that the indoor wiring for the power supply is rated at 15 A or higher (AC single phase 100 V ~ 120 V area), and 7 A or higher (AC 220 V ~ 240 V area). Non-compliance with the Electrical Specifications can cause a fire and electric shock.

Be sure to use an independent power supply equipped with an earth leakage breaker. Using a power supply without an earth leakage breaker can cause an outbreak of fire if a power surge occurs.

Putting many loads on one electrical outlet can cause generation of heat and a fire resulting from overload.

When using an extension cord, ensure that the cord is rated at 15 A or higher (AC 100 V ~ 120 V area) and 7 A or higher (AC 220 V ~ 240 V area). Using a cord rated lower than the specified rating can cause a fire and electric shock.



## 2-2 OPERATION AREA

### **STOP** IMPORTANT

To install this product, the entrance must be at least 1.58m in width and 2.2 m in height.

Do not attempt to move the product by pushing or pulling on the plastic parts. This may damage the product and may cause personal injury.

### **WARNING**

- For the operation of this machine, secure a minimum area of 2.83 m (W) x 3.1m (D). These dimensions are necessary to enable the customer to walk around the machine and also to provide adequate ventilation. This machine is a ride, so there is a possibility of a player falling off. In such an event, if a player strikes his or her head, a serious accident may occur, so be sure to secure the minimum area around the machine specified in this manual.
- Be sure to provide sufficient space specified in this manual. Do not allow objects to block the ventilation ports. It can cause generation of heat and a fire.
- SEGA shall not be held responsible for damage or compensation for damage to a third party, resulting from the failure to observe this instruction.
- If the machine does not fit through the entryway to the installation location, do not disassemble it without first consulting the instructions. The machine should only be disassembled in accordance with the instructions listed in this manual; do not attempt to disassemble it in any other way. Specific tools and adjustment procedures are required to assemble and disassemble the mechanical parts. Attempting to assemble or disassemble the machine without consulting the instructions may result in accidents during assembly/disassembly and electric shock, short circuits, and/or personal injury during operation. If the machine still does not fit through the entryway after following the procedures in this manual, contact your retailer or the office listed in this manual.
- If the machine is still too large to fit through the entryway after following the procedures listed in this manual, do not tip the machine on its side. Attempting to transport the machine while it is tipped on its side may cause accidents. It may also damage or warp parts of the machine, resulting in accidents during operation.
- To install this product, the entrance must be at least 1.58 m in width and 2.2m in height. If the entrance is too narrow, do not tilt the product carelessly. If all the product weight is put on the casters at one side only, there could be damage or deformation, causing serious accidents such as workers getting caught underneath.

## OPERATION AREA

### 2 PRECAUTIONS REGARDING INSTALLATION LOCATION

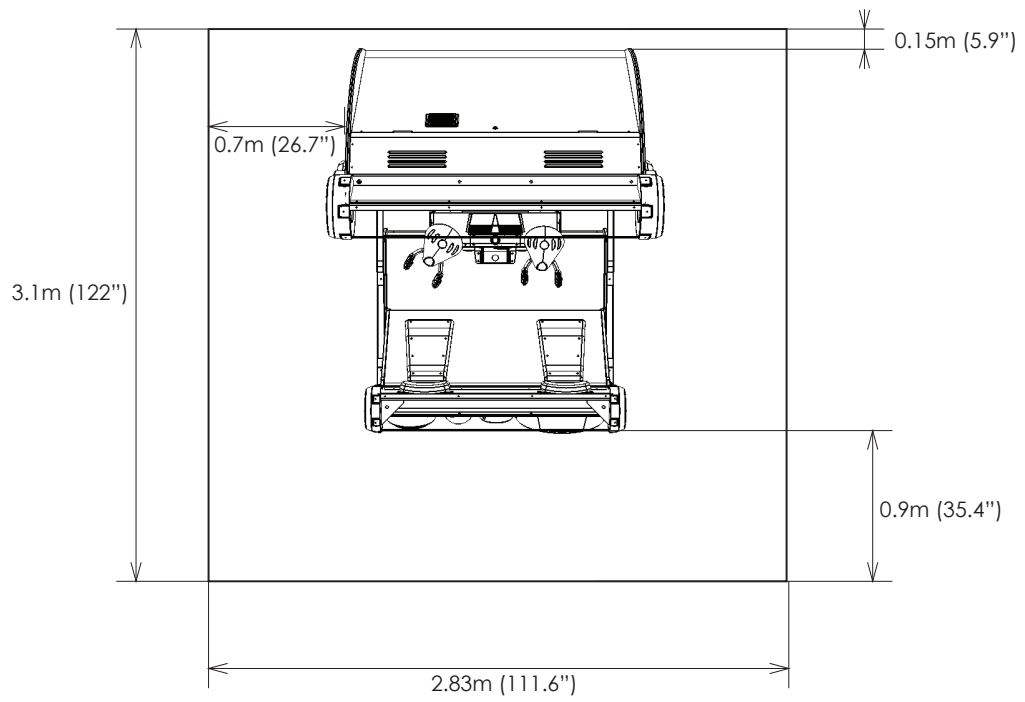

### 3 PRECAUTIONS REGARDING PRODUCT OPERATION

In order to prevent accidents and inappropriate behaviour, please check the following before operating the product.

#### 3-1 BEFORE OPERATION

##### WARNING

- To ensure maximum safety for the players and the customers, ensure that where the product is operated has sufficient lighting to allow any warnings to be read. Operation under insufficient lighting may result in customers bumping into each other or the product causing injury.
- Check if all the Leg Adjusters are in contact with the surface. (The casters should be raised approximately 5mm from the floor) If they are not the cabinet will move and may cause damage to property or injury to a player or observer.

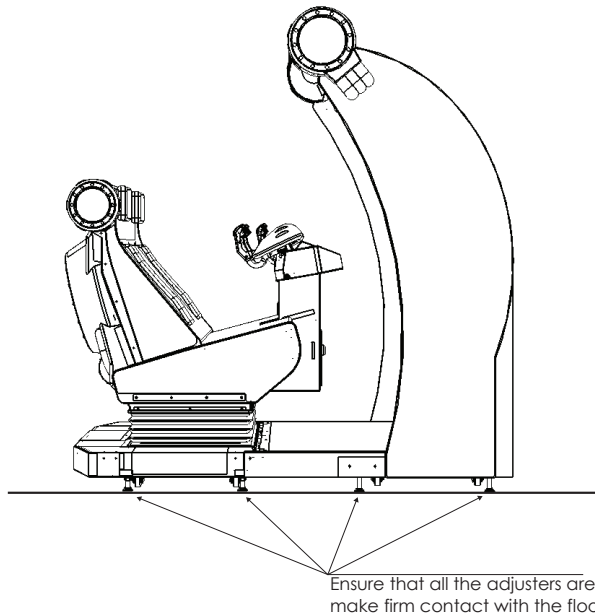

- Do not place any heavy items on this product. Doing so may result in injury or damage to the product.
- Do not climb on this product. Climbing on this product may result in injury or product damage. When checking the upper proportions of this product, always use a step/step ladder.
- To avoid electric shock, always check each door or service hatch for damage and make sure that they are fitted correctly. Never operate this product with doors or service hatches removed.
- Do not place any of the following objects on top of the product, nearby the product or hang them from the ceiling in close proximity to the product as doing so may result in an electric shock, short circuit or damage to parts.
- Flower vases, flower pots, cups, glasses, water tanks, cosmetics and/or any receptacle/container/vessel containing liquid or chemicals.

 **WARNING**

- Check each safety device and also check to see if any of the rides move abnormally. Abnormal motion may cause an accident, so do not operate the machine until the cause of the abnormality has been removed.
- Does the ride move in the direction corresponding to the direction of operation?
- Does the ride move smoothly?
- Is there any undesirable looseness in the ride?
- Is any unusual noise emitted while the ride is operating?
- Is any unusual vibration emitted while the ride is operating?
- Does the ride stop at an even position when the game is over?
- Are there any cracks or breaks in places such as the handle that the player touches?
- Are there any foreign objects in the seat?
- To ensure safety, carry out a trial run before operation, and be sure to check the safety devices such as the “MOTION STOP” button.
- Inspect the seat to make sure it moves correctly. Abnormal movement of the seat could lead to accidents, so do not make the game available for play until any abnormalities have been resolved.
- Check the surrounding area before applying power. The product will perform the initializing operation automatically after the power has been turned on. If there are people near the product during this time they may be struck or knocked over when the seat moves.
- The motion of the seat will not stop if touched by anybody observing the game. The seat will only cease movement when the “MOTION STOP” button is pressed.
- Stop the operation immediately if ever the movement mechanism fails. Turn off the power, unplug the power cord from the outlet and contact your local distributor or any of the contacts listed at the beginning of this manual.
- If any part of the movement mechanism requires maintenance, contact the party listed in this manual or the point of purchase.
- **DO NOT CONTINUE USE** if any part of the motion mechanism fails, doing so may result in a major accident or injury.
- Be sure to perform appropriate adjustment of the LCD. For operation of this machine, do not leave monitor’s flickering or deviation as is. Failure to observe this can have a bad influence upon the players’ or the customers’ physical conditions.
- It is suggested to prepare a rest space for players who feel sick after playing the game.

## CAUTION

- Inspect for the following items during a trial run. If there is any type of error, use the Test Mode, etc., to resolve the problem. If you continue use with an error, it can cause an accident or irreparable parts damage.
  - Does the ride move smoothly during the initialization operation?
  - Are the bellows torn or has a screw dropped out of them?
- During daily cleaning, be sure to check the surface of the controllers and other parts that the player touches with his hands for damage, cracks, or loose screws. If a player uses the machine while it is damaged, cracked, or has a loose screw, the player may become injured.
- During daily cleaning, be sure to check the seat for any abnormality, wetness, etc. Failure to do this may result in deliberate tampering or negligence being left undetected.
- Ensure that both blower grills are free from obstructions such as pieces of paper / sweet wrappers etc.

## STOP IMPORTANT

- Players directly hold the controller with their bare hands so it is recommended that wet towels (paper towels) be provided.
- Endeavor to clean the controllers and seat frequently.
- Provide a container or space for storing the customers' hand luggage, etc. To help prevent an accident and also protect parts, establish measures so that customers do not bring raingear, such as umbrellas, on rainy days, or juice or other beverages, into the area where the machine is installed.
- Inspect the coin insertion slots to make sure that no foreign objects have been inserted and that they have not otherwise been tampered with as this will prevent play.



## 3-2 DURING OPERATION (PAYING ATTENTION TO CUSTOMERS)

In order to prevent an accident or unnecessary trouble, the attendant or operator must endeavor to always pay attention to the behavior of the players and customer. This machine has movable rides of about the same size as an automobile. Sometimes a player or a customer may behave in an unexpected way. Be adequately aware of safety, and stop any behavior that is considered dangerous.

### WARNING

- For safety reasons, do not allow any of the following people to play the game.
- Those who have high blood pressure or a heart problem.
- Those who have experienced muscle convulsion or loss of consciousness when playing video games, etc.
- Those who have neck or spinal cord problems.
- Those who are intoxicated or under the influence of drugs.
- Pregnant women.
- Those who are not in good health.
- Those who do not follow the attendant's instructions.
- Those who cannot grasp the Control Unit securely because of immobility in fingers, hands or arms.
- Persons who disregard the product's warning displays.
- This product is intended for a single or dual players only. Having three or more persons simultaneously playing this product can result to injury to the player and possible damage to the product.
- Even players who have never been adversely affected by light stimulus might experience dizziness or headache depending on their physical condition when playing the game.
- Small children are especially likely to experience these symptoms. Caution guardians of small children to keep watch on their children during play.
- Instruct those who feel sick during play to have a medical examination.
- To avoid injury from falls and electric shocks due to spilled drinks, instruct the player not to place heavy items or drinks on the product.
- To avoid electric shocks and short circuits, do not allow customers to put hands and fingers or extraneous matter in the openings of the product or small openings in or around the doors.
- To avoid falls and resulting injury, immediately stop the customer from leaning against or climbing on the product, etc.
- To avoid electric shock and short circuit, do not allow customers to unplug the power plug without a justifiable reason.
- Instruct the guardians of small children to keep an eye on their children.
- Children cannot sense danger. Allowing small children to get near a player who is playing the game could result in the children being bumped, struck or knocked down.

## WARNING

- Instruct customers not to get on or in any ride part, such as the rear of the ride or behind the back of the seat, other than the seat. Failure to observe this precaution may result in players falling over, falling off, or catching body parts in the ride.
- Entering the cabinet with a wet umbrella or wet shoes is strictly forbidden. There are electrical parts and wiring underneath the cabinet floor. If these become wet, this can cause an electric shock or short circuit. Be especially careful in managing the product on days when it rains.
- Take care not to place a heavy object on a ride or seat. This may cause the object to strike the player when the ride moves.
- Instruct customers not to play a game with a child on their knees. This may cause an accident such as the child becoming caught between the control panel and the player or the child falling off the ride.
- Instruct players not to stand during a game in which the ride moves. This may result in the player falling off the ride or falling over.
- Instruct persons other than players to keep away from the machine while a game is in progress. If a person touches the moving ride, this may result in an accident such as the person falling over or getting his or her fingers caught in the bellows.
- An infant is unable to recognize danger, so instruct the guardian of the infant to be attentive and ensure that the infant does not approach the machine.

## WARNING

- For safety reasons, do not allow any of the following people play the game.
  - Those whom require supporting devices, etc., to walk,
  - Those who are intoxicated or under the influence of drugs.
  - Persons who disregard the products warning displays.
  - Persons under 110cm (43.3 in) in height.
  - Person over 135 kg (297lb) in weight or a combined weight of 270 kg when in 2 player game.
  - The game cannot be played whilst sitting in a wheelchair or buggy.

 **CAUTION**

- Immediately stop such violent acts as hitting and kicking the product. Such violent acts can cause parts damage or cause the cabinet to fall over, resulting in injury.
- Items such as large finger rings can cause injury to the fingers while playing. Instruct players to remove all accessories that could cause an accident before playing.
- Take care to ensure that two persons do not attempt to play a game by grasping a single controller. Failure to heed this precaution may result in a collision between two players which may cause an injury.
- Explain that the MOTION STOP button can be pressed to stop play whenever the player feels ill.
- Explain that the attendant will stop the game if he or she judges that a situation is dangerous.
- Take care to ensure that other customers do not touch operating devices during a game. Failure to heed this precaution may result in an accident or cause trouble between customers.
- There are steps and level differences on each ride, so instruct players to be careful when getting on or off the ride.
- Do not allow players to extend their hands or feet out from the ride during play. Otherwise there could be bruises, sprains or other accidental injuries.
- Instruct the player to adjust the seat in the front-rear direction to match his or her body size. If a player plays a game in an unreasonable posture, he or she may sustain an injury or incur discomfort.

 **IMPORTANT**

- If a player carries hand luggage or other items onto a ride, objects may fall off or roll over, for example, when the ride moves, resulting in injury or damage. Also, instruct players not to take breakable items, etc., onto the ride.
- After the end of a game, check to ensure that the player has not forgotten or dropped any belongings.

## 4 PART DESCRIPTIONS

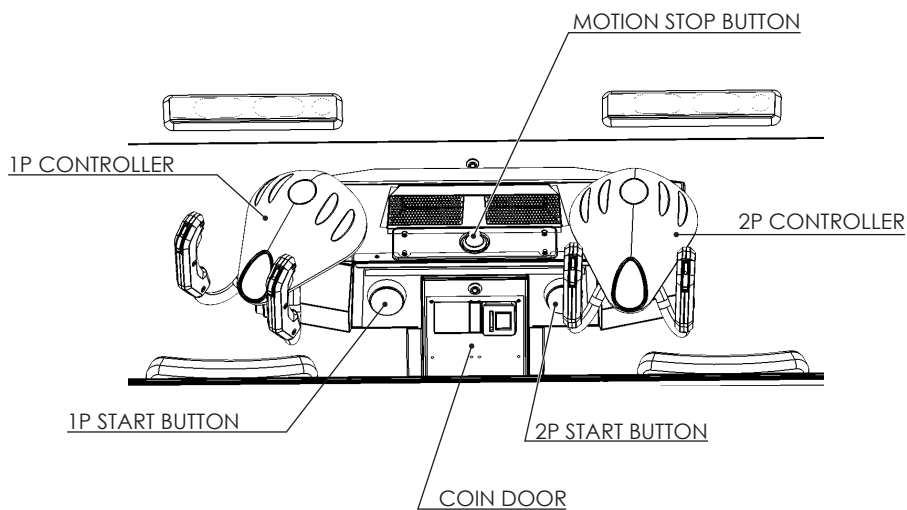
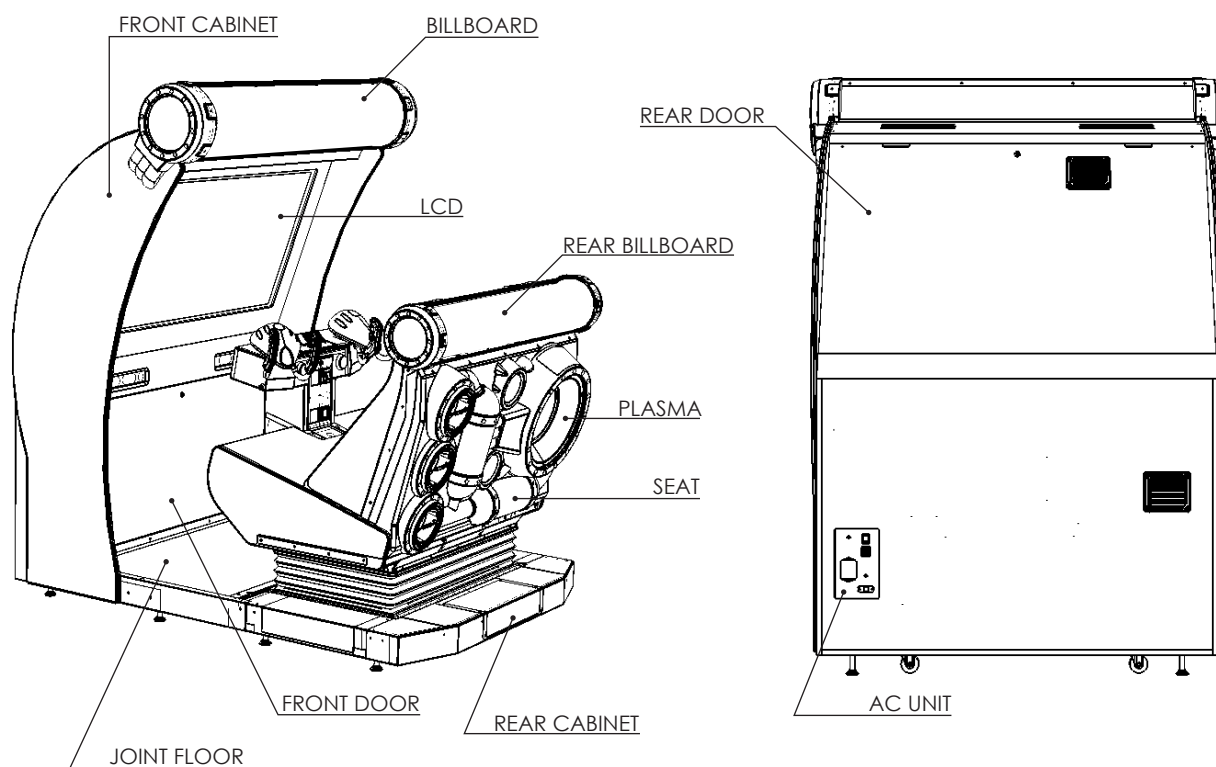

Items	Width	Depth	Height
FRONT CABINET (WITHOUT BILLBOARD)	1,436mm (56.53 in)	880mm (34.64 in)	2000mm (78.74 in)
REAR CABINET	1,395mm (54.92 in)	1,290mm (50.78 in)	1,390mm (54.72 in)
JOINT	1,395mm (54.92 in)	812mm (31.96 in)	110mm (4.33 in)
BILLBOARD (INC END CAPS)	1,576mm (62.04 in)	383mm (15.07 in)	416mm (16.37 in)
INSTALLED WEIGHT	590 kg (1300.7 lb)		



## 5 ACCESSORIES

Confirm that the accessories listed in the table below are present when setting up the product. Accessories marked “Spare” in the note column are consumable items but included as spares.

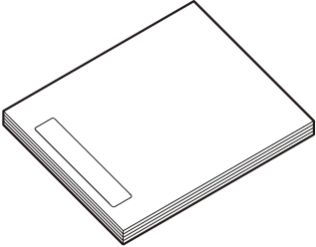
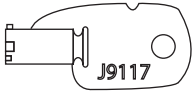
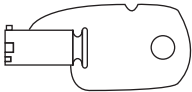
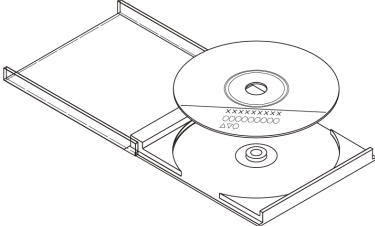
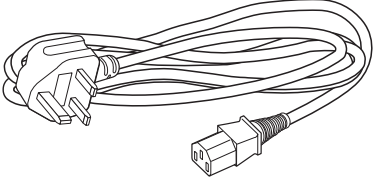
Parts not labeled with part numbers are yet to be assigned. Be sure to handle all parts with care, as some parts are not available for purchase separately.

Part name/Part no.	Description/Use etc.	Qty
OWNERS MANUAL 420-0016UK	This Manual 	1
KEY MASTER	For all service doors 	6
KEY	For Cashbox security door 	2
DVD SOFTWARE	For re-installing software 	1
POWER LEAD	Power cord for your region 	1

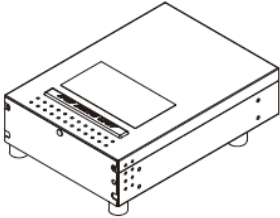
The DVD drive is sold separately but it is required in order to install the software for this product. If you do not have the drive when re-installing the product, consult the dealer which you purchased this product. Alternatively use the kit number below when ordering the drive from the SEGA SPARES DIVISION.

Part name/Part no.	Description/Use etc.	Qty
DVD DRIVE 610-0719-01-91		1
DVD WIRE 605-0094		1

## **6 ASSEMBLY AND INSTALLATION**

### **WARNING**

- Perform assembly work by following the procedure herein stated. Failure to comply with the instructions can cause electric shock.
- Perform assembling as per this manual. Since this is a complex machine, incorrect assembling can cause an electric shock, machine damage and/or improper functioning as per specified performance.
- When assembling, be sure to use additional help from another person(s). Depending on the assembly work, there are some cases in which working by one person alone can cause personal injury or parts damage.
- Adhere strictly to all of the work procedures stipulated in this document. If two or more workers are working at the same time, exercise special caution. If sequences are carried out erroneously, accidents can result. There might also be cases in which the assembly cannot be completed.
- Pay special attention to the surroundings when a multiple number of workers are working at the same time. There is always the danger that a worker might be injured. In assembly and installation of this product, there are procedures in which a stepladder is used, procedures in which heavy objects are attached, and procedures involving connection of a rated power supply of 10 amperes. Carelessness in doing work could lead to grave injuries and even fatalities.
- Ensure that connectors are accurately connected. Incomplete connections can cause electric shock.
- This work should be carried out by the site maintenance personnel or other qualified professionals. Work performed by non-technical personnel can cause a severe accident such as electric shock. Failing to comply with this instruction can cause a severe accident such as electric shock to the player during operation. If no one with proper technological expertise is available, request service from the office indicated in this document or the point of purchase so as to ensure safety.
- Be careful not to damage the wires. Damaged wires may cause electric shock or short circuit or present a risk of fire.
- Do not leave power cable or earth lines exposed over passageways. Exposure could lead to damage, electric shock or short circuit. Wherever wiring has been laid out on a floor surface, use a wiring protection cover. [Wiring diameter: Power cable, approx. 10 mm – 14 mm]
- Persons who connect indoor power supplies must be qualified electricians. Do not allow anyone without proper qualifications to make such connections. Otherwise there could be electric shock.
- Provide power cables for connecting the indoor power supply to the product. The rating of the power cable must be at least 15 amperes. The cable must conform to this requirement and also be of sufficient length to enable the indoor power supply to be connected to the product without difficulty. Use of a cable that does not meet the requirements can result in a fire or electric shock. The recommended dimensions of the power cable terminal for the product use are a hole diameter of 4.5 mm and width of 8 mm.





**⚠ WARNING**

- For the sake of safety and workability, use 3 core coaxial CE/UL approved cables for the power cables (provided).
- When inserting or removing a connector, always hold it by its main part. If you hold it by anything else while doing so, the connections between wire and connector terminal fixtures could be damaged; and there could be a short circuit or fire. There could also be poor connectivity.
- Make sure that all the adjusters are resting on the floor. The cabinet may move and cause an accident if the adjusters are not laid out properly.
- Whenever any fasteners (e.g. screws, nuts) have been lost, always use replacement fasteners with proper dimensions as specified in this manual. If fasteners of any other dimensions are used, it could cause damage and/or separation of parts that result in secondary accidents.
- Be careful when aligning, attaching or mounting parts so that your head, hands, fingers, etc., do not get caught in anything. If two or more workers are working at the same time, exercise special caution. Failure to be cautious could result in accidental bone fractures or amputation. Check the surroundings carefully before proceeding.
- When connecting wires inside the cabinet, there may be instances in which the indoor lighting does not reach that location. Have a flashlight or other auxiliary lighting equipment on hand. If wires are connected carelessly, there could be an accidental short circuit, fire, etc.
- When tightening bolts and screws, ensure that other parts are suspended properly and bolts and screws are fastened tightly. Be sure to take accident prevention measures such as having another worker support parts. If a part drops or topples over during this work, a serious accident may result.

**⚠ CAUTION**

- Support and hold parts in place securely and fasten them with screws and/or bolts. Use two workers, one to support the part and another to fasten it in place. If a part is not supported securely, it might fall down, resulting in an accident.
- Wear appropriate work clothing so that work can be performed safely. Use gloves and safety shoes to prevent accidents or injuries.
- When installing a wire protection cover over a floor, use a material shaped so that no one passing by will stumble over it. Using a material that could be stumbled over might lead to an accidental fall.
- Be careful in handling plastic parts. Be sure not to tighten screws or nuts too tightly. If such parts are exposed to excessive loads or impact, they might become damaged, resulting in fragments or cracks that could cause accidental injury.

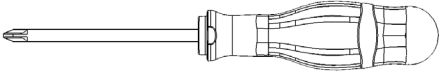
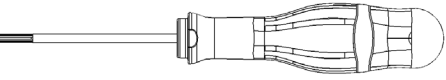
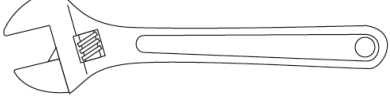
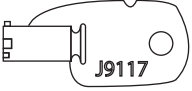
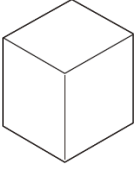
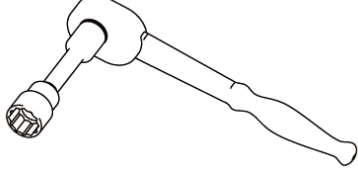
**TOOLS NECESSARY FOR WORK**

Phillips Screwdriver (for M4)	
Torx T20 Security Driver	
Spanner / Adjustable spanner (24mm)	
Key Master	
Step or Stool	
Socket Wrench (13mm)	
Hex Key	

## 6-1 CONNECTING FRONT AND REAR CABINETS

- 1 Move the Display Cabinet to the installation location. Be carefully not to push on the screen or the plastic components. Place the product so that the back of the front cabinet is at least 0.15m (5.9 in) from the wall.
- 2 Using a 24mm spanner, lower the Leg Adjusters until the casters have been raised from the ground approx 5mm.

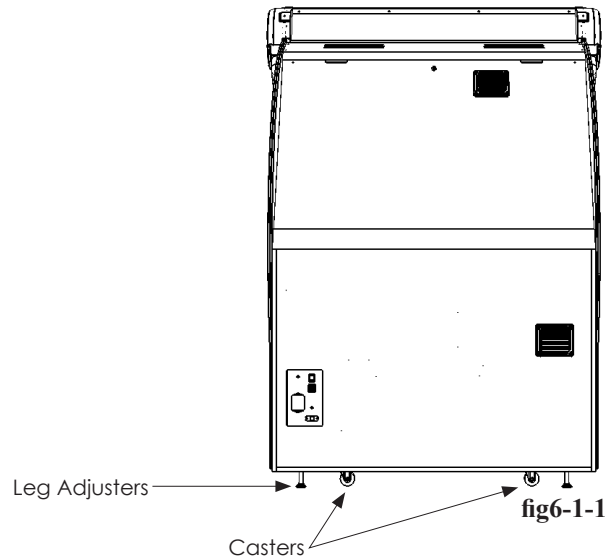

- 3 Once the Display cabinet is secure to location, fit the 2x Joint Bridges (DV-0001UK) to the base of the display cabinet. First remove the 8x fixings from the location points and slide the 2x Joint Bridges into position. Once in position re-fit the 8x fixings back into their location points. (do not tighten at this stage). There is a total of 8 fixings in this step.

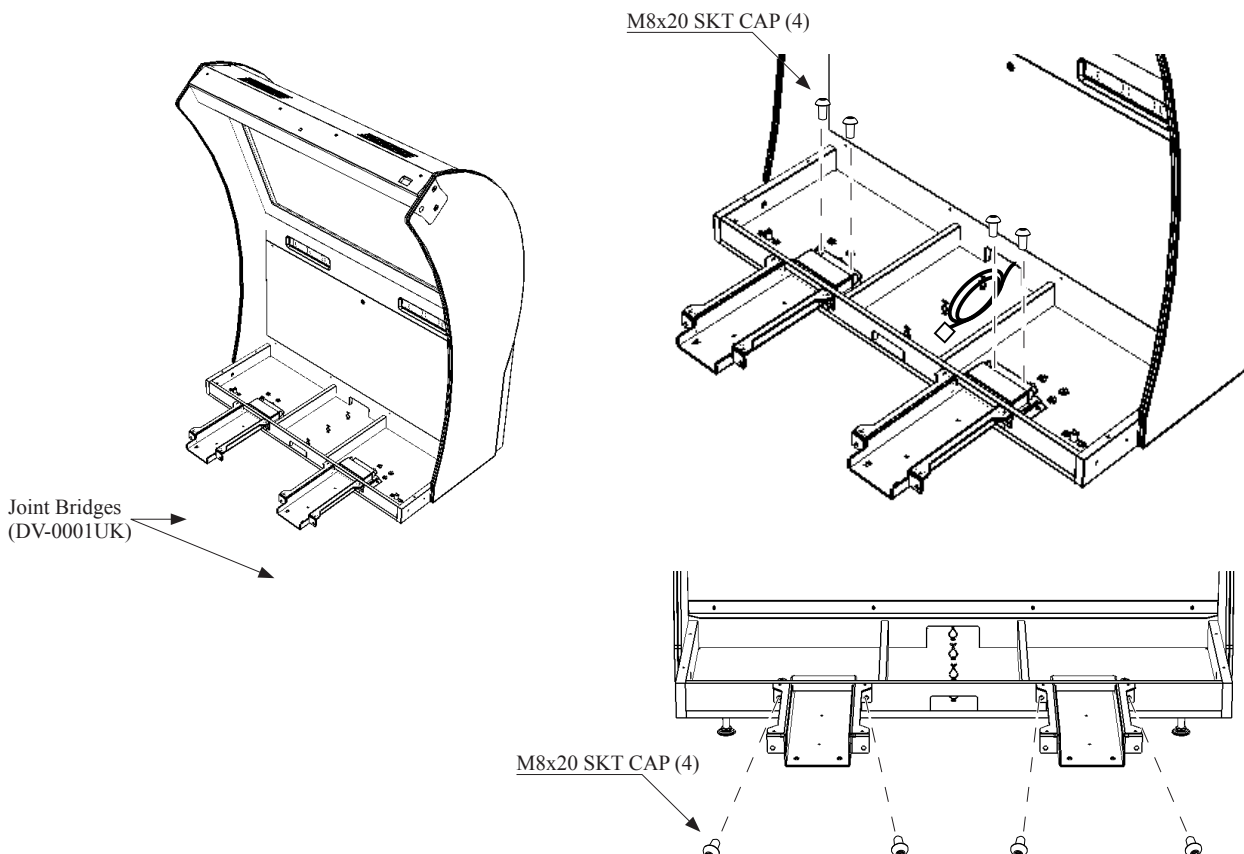

- 4** Fit the Board Harness (DV-0010UK) to the underside of the Joint Bridges and secure using the 4x M4 SKT CAP SCREWS.

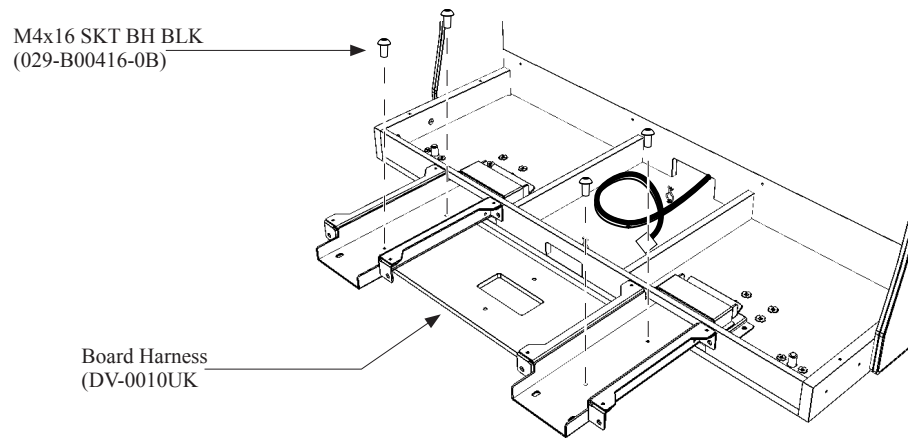

- 5** Route the harness from the Display cabinet through to the front of the Board as illustrated.

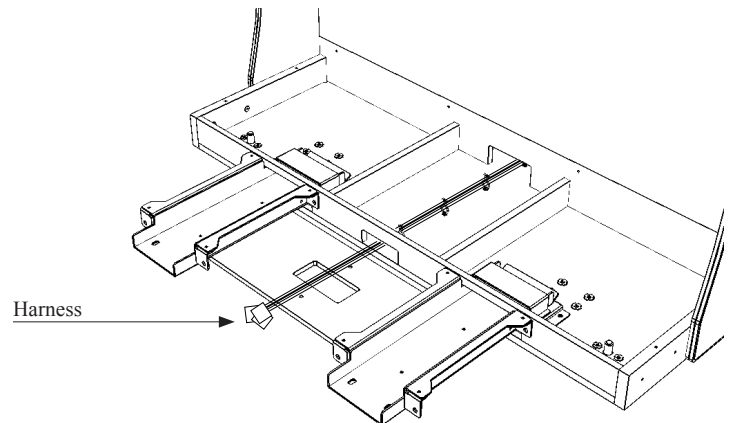

- 7** Carefully maneuver the Moving Seat cabinet into position so that the Joint Bridges located firmly into position. Take care not to trap and wires when positioning the cabinet together.

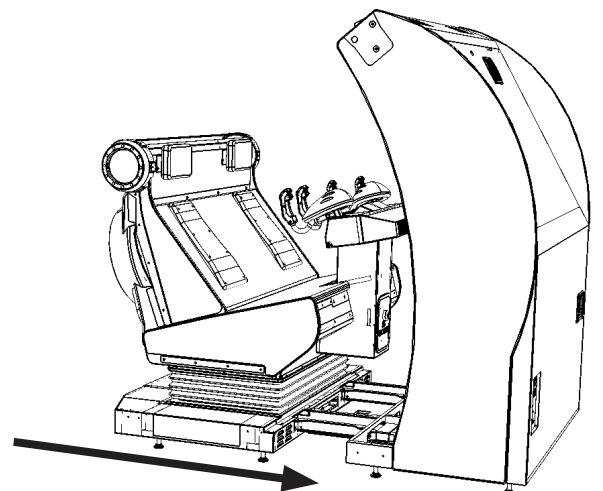

- 8 Once the Motion Seat cabinet is secure to location, fit the 2x Joint Bridges (DV-0001UK) to the base of the Motion Seat cabinet. First remove the 8x fixings from the location points and slide the 2x Joint Bridges into position. Once in position re-fit the 8x fixings back into their location points. (Tighten all 16 fixings).

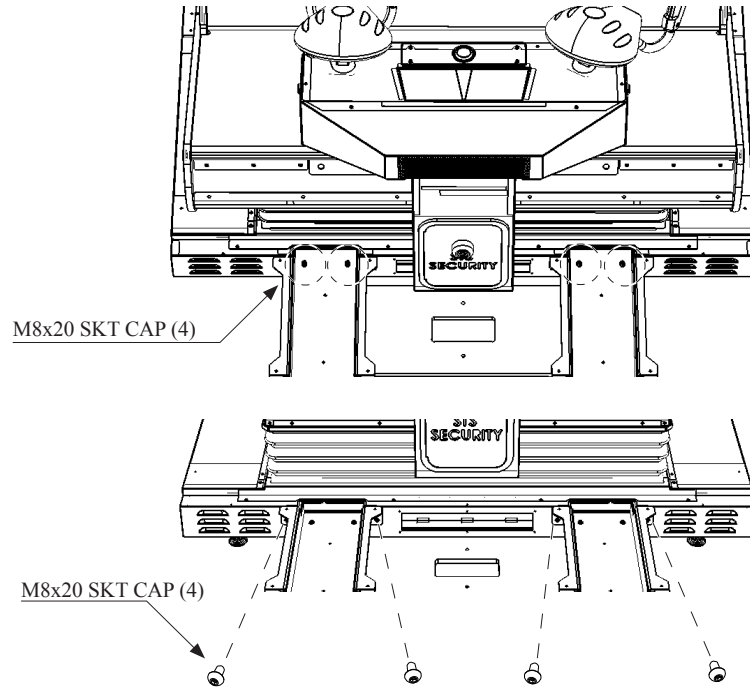

- 9 Make all connections on the joining harness good.

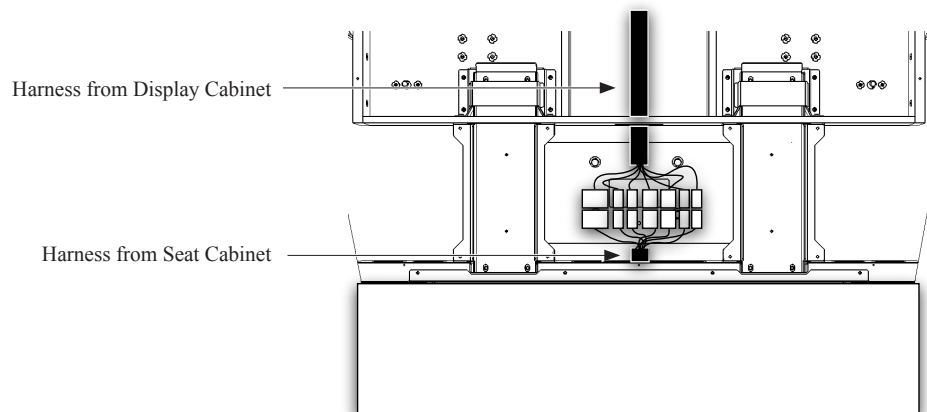

## 6-2 INSTALLING THE FLOOR

- 1 Place the floor [DV-0002UK] into the space between the two cabinets, taking note of orientation. Secure into position using the JOINT SASH REAR [DV-0004UK] and secure using M4x14 SKT BH BLK [029-B00416-0B] (4), M4 WSHR BLK 16OD [068-441616-0B] (4) and M4 WSHR SRNG BLK [060-S00400-0B] (4)

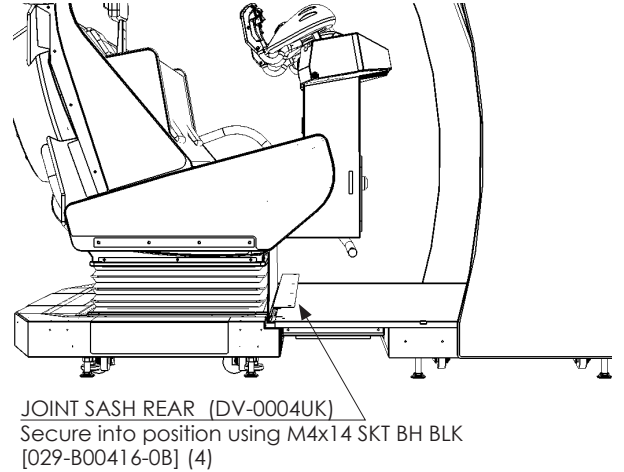
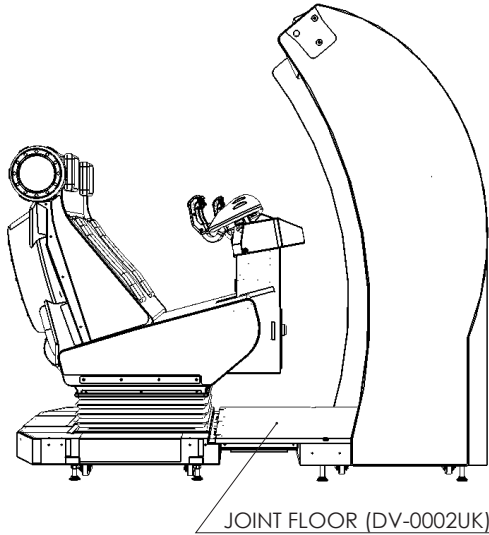

- 2 Fit both JOINT SASH SIDE L [DV-0008UK] and JOINT SASH SIDE R [DV-0009UK] to the outer sides of the floor and secure using M4x25 SKT CAP CRM [020-000425-0C] (3) and M4 WSHR FLT CRM 16OD [068-441616-0C] (3)

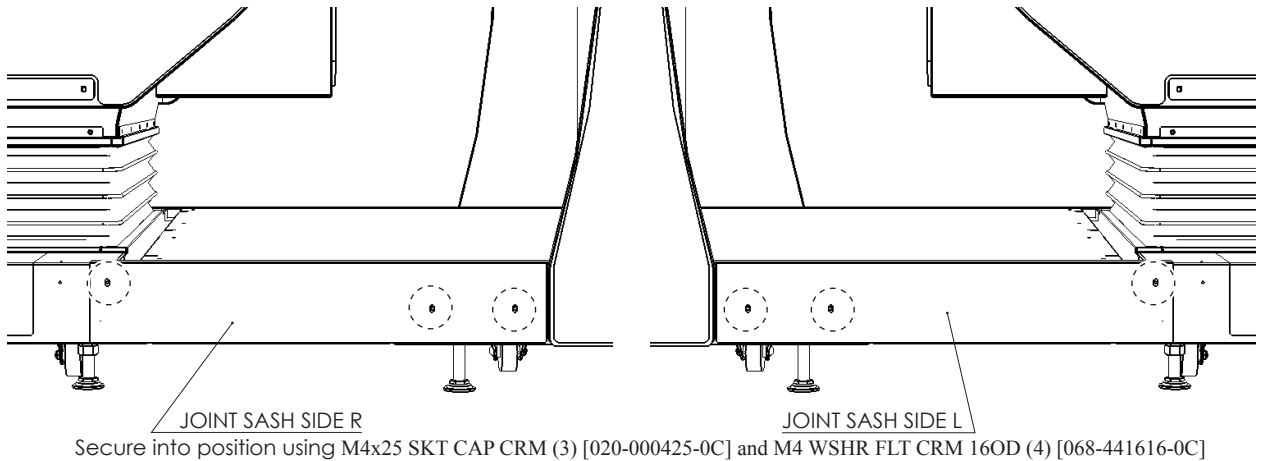

- 3** Fit and secure the JOINT SASH FRONT (DV-0006UK) to the front edge of the floor, Secure into position using M4x14 SKT BH BLK [029-B00416-0B] [4] [068-441616-0B] [4] and (060-S00400-0B) [4]

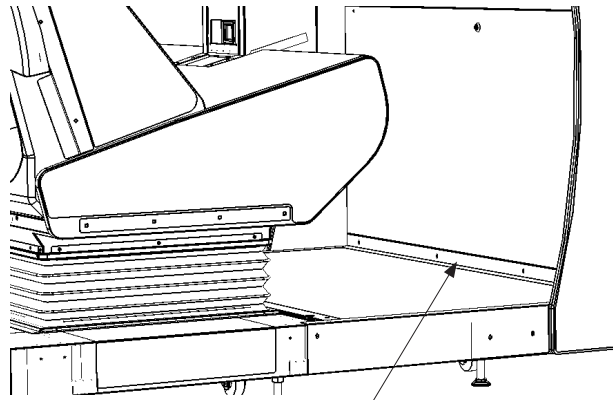

JOINT SASH FRONT (DV-0006UK)

Secure using M4x14 SKT BH BLK [029-B00416-0B] [4] [068-441616-0B] [4] and (060-S00400-0B) [4]

## 6-3 INSTALLING THE BILLBOARD

- 1 Correctly position and secure the END CAP INNER (2) [DV-0512UK) to the ASSY BILLBOARD and secure using the M8x70 BLT PAS (4) and M8 WSHR 22OD FLT BLK (4). Do not tighten fixings at this point as it may prevent fixture to cabinet.

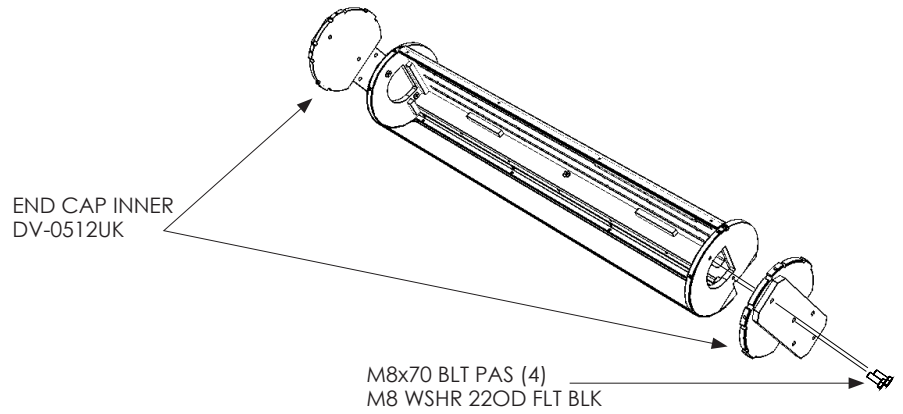

- 2 Using a minimum of 2 people and either a step or step ladder, carefully raise the Ass'y Billboard into position. Make Billboard connection good before finalising position.

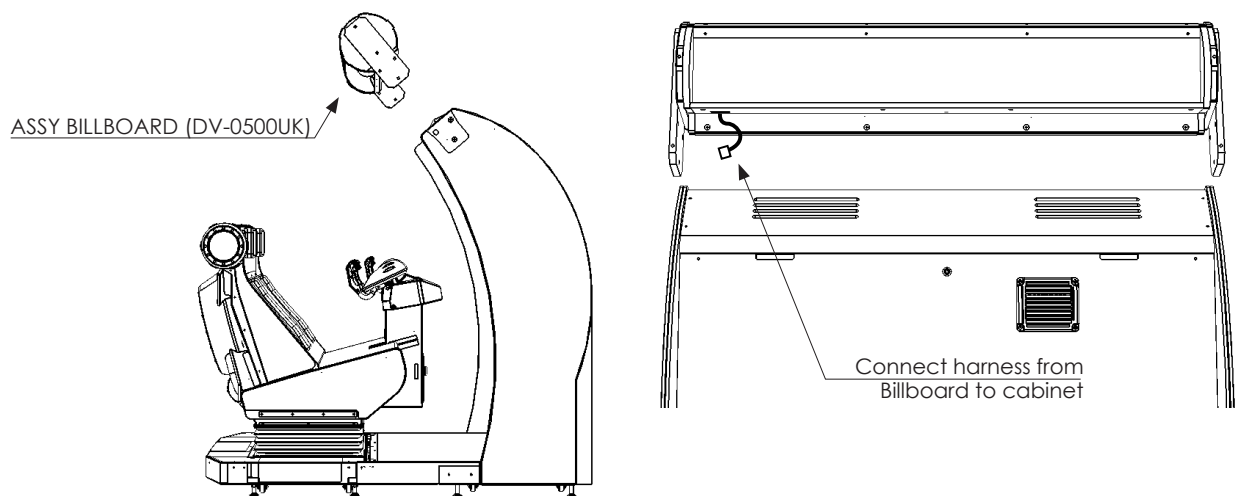



- 3** Align the 3 holes each side of the Billboard and secure to cabinet using M8x50 BLT PAS (6) [030-00850] and M8 WSHR 20OD FLT BLK (6) [030-000850] - Tighten all 10 fixings.

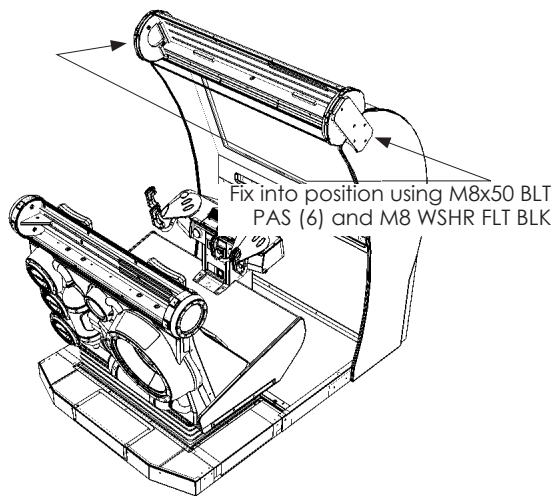
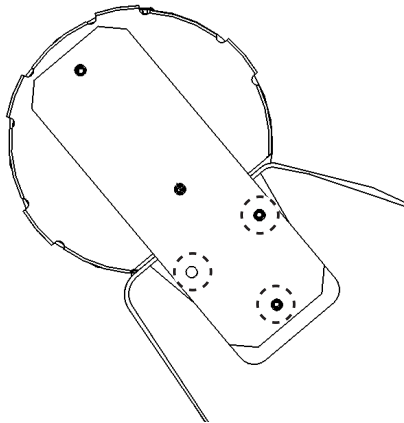

- 4** FIT END CAP HEADER (2) [DV-0513UK] to both ends of the ASSY BILLBOARD and secure using M4x12 TMP PRF STN (8) [008-OS0412] and M4 WSHR 16OD FLT CRM (8) [068-441616-0C]

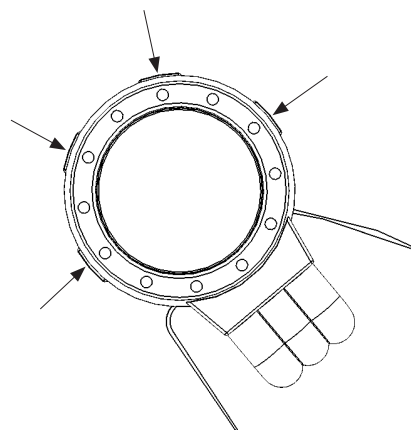
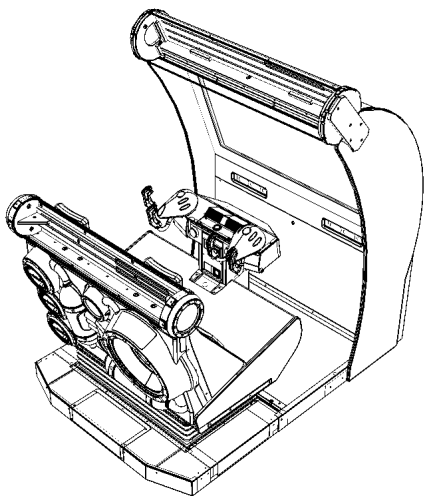

## 6-4 FIXATION TO SITE

### ⚠ WARNING

- Make sure that all the adjusters contact the floor. Otherwise the cabinet could move, causing an accident.
- Provide a ventilation space at least 15cm wide behind the cabinet. There are ventilation holes on the back of the cabinet. Do not block the ventilation holes. Doing so could trap heat inside resulting in fire. It could also result in equipment damage or cause parts to become exhausted prematurely.
- Do not position the product on uneven surfaces or a surface which slopes. Positioning the cabinet on either an uneven or sloped surface may cause the cabinet to become unstable which may result in damage or injury.

The product comes with castors attached to 8 locations. When the installation site has been determined, have the adjusters come in direct contact with the floor. Establish a gap of approximately 5mm between the floor and the castor and adjust the unit so that it will remain level.

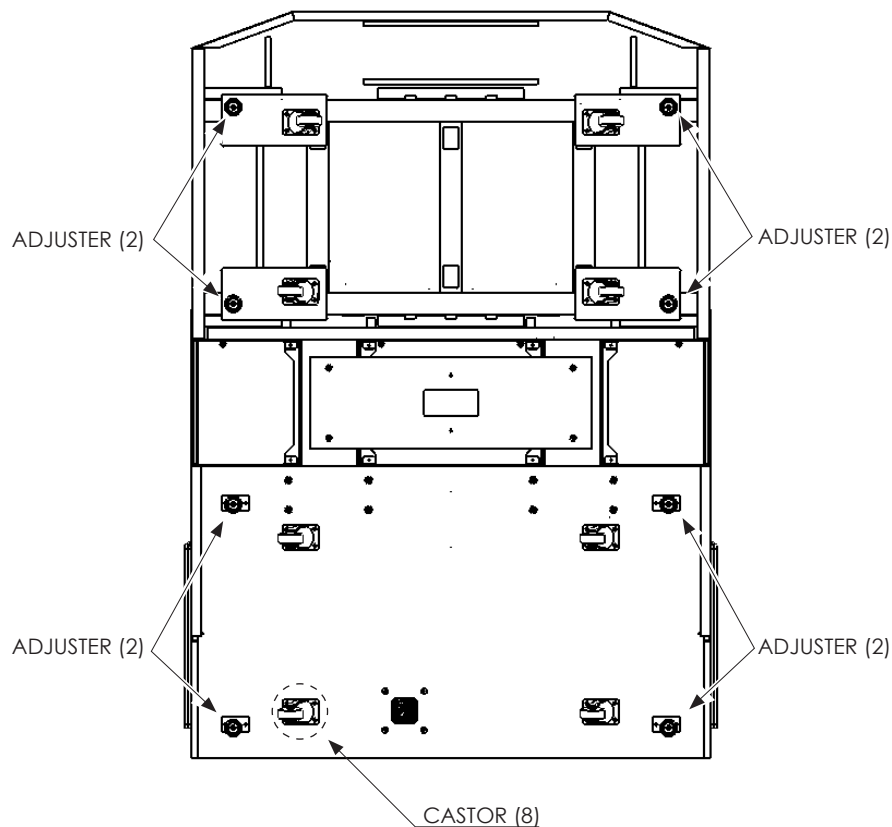

- 1** Move the product to location. When adjusting the front cabinet position, use the parts which are shaded to hold the cabinet. Be careful not to push/pull on the screen or any plastic parts which may break.

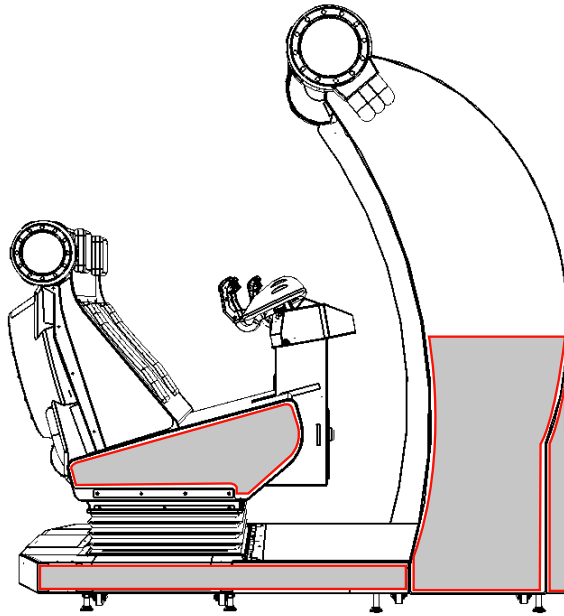

- 2** Bring the adjusters into direct contact with the floor. Use a wrench to align the height of the adjusters until the cabinet is perfectly level. Not having the adjusters level will cause the cabinet to rock and move from position..

- 3** After setting, screw the nuts upwards to the base and tighten. This will prevent the adjusters from moving.

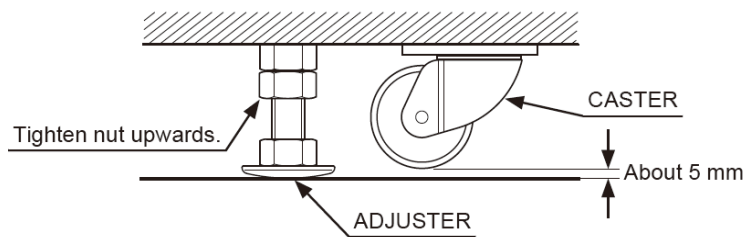
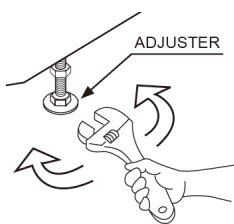

## 6-5 POWER SUPPLY AND OTHER CONNECTIONS

### WARNING

- Use the power supply equipped with an earth leakage breaker. Use of power supply without such a breaker could result in fire if there is a current leakage.
- Have available a securely grounded indoor ground terminal. Without proper grounding, customers could be electrocuted and product operations might not always be stable.
- Do not expose the power cord or ground wire. If these are exposed, customers could stumble over them, for instance, and easily damage them. Additionally, if these lines are damaged, there could be a risk of electrical shock or short circuit. Set these lines at locations where they will not interfere with customer traffic, or attach covers to them.
- After laying out the power cord on the floor, be sure to always protect it. If the power cord is left exposed, it can easily be damaged, resulting in electrical shock.

**1** Confirm that the main switch is at OFF position.

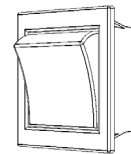
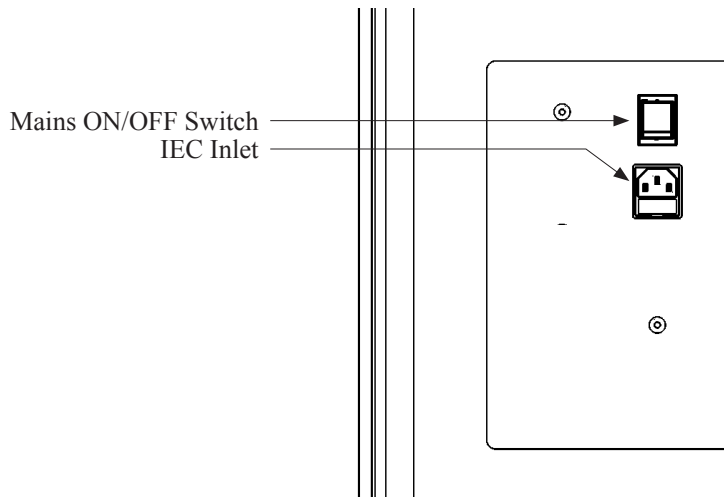

Mains Switch shown in OFF position

- 
- 2** Fully insert the power cord connector on the side opposite the power plug into the AC unit IEC inlet. Insert the power cord plug into the outlet.
- 

- 3** The power code is laid out indoors. Protect the power cord by attaching wire cover to it.

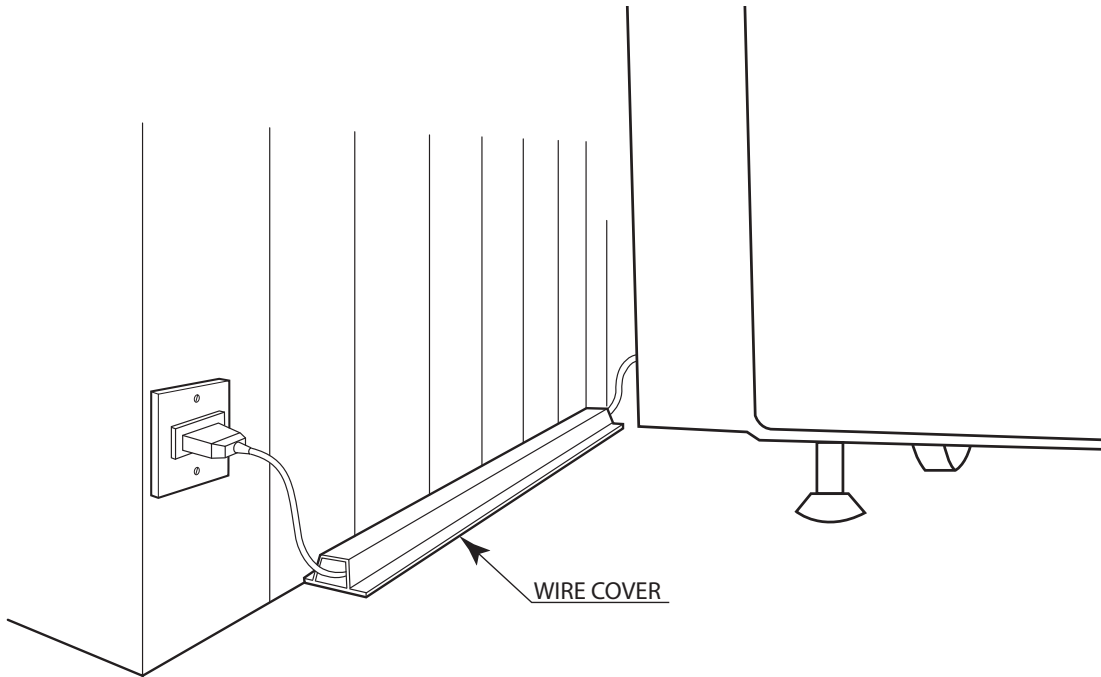

## 6-6 TURNING ON THE POWER

Set the main switch of the AC unit to ON and engage the power.

When you turn on the power, the billboard LED's will come on.

After the start up screen is displayed on the LCD screen, the Advertise (Attract) Mode will start.

The decorative LEDs within the REAR MOULDING will illuminate and scroll through a variation of colours and the PLASMA DISC will generate patterns in-time with the music/audio.

Start up sounds are output from the speakers on the left and right of the cabinet together with display of the startup screen.

Even when the power source has been cut off, credit count, ranking data, game settings and bookkeeping data are kept stored in the product. However, fractional coin counts (inserted coins that do not amount to one credit) and bonus adder counts are not kept.

# COMPONENTS WHICH CHANGE STATE WHEN POWER IS APPLIED

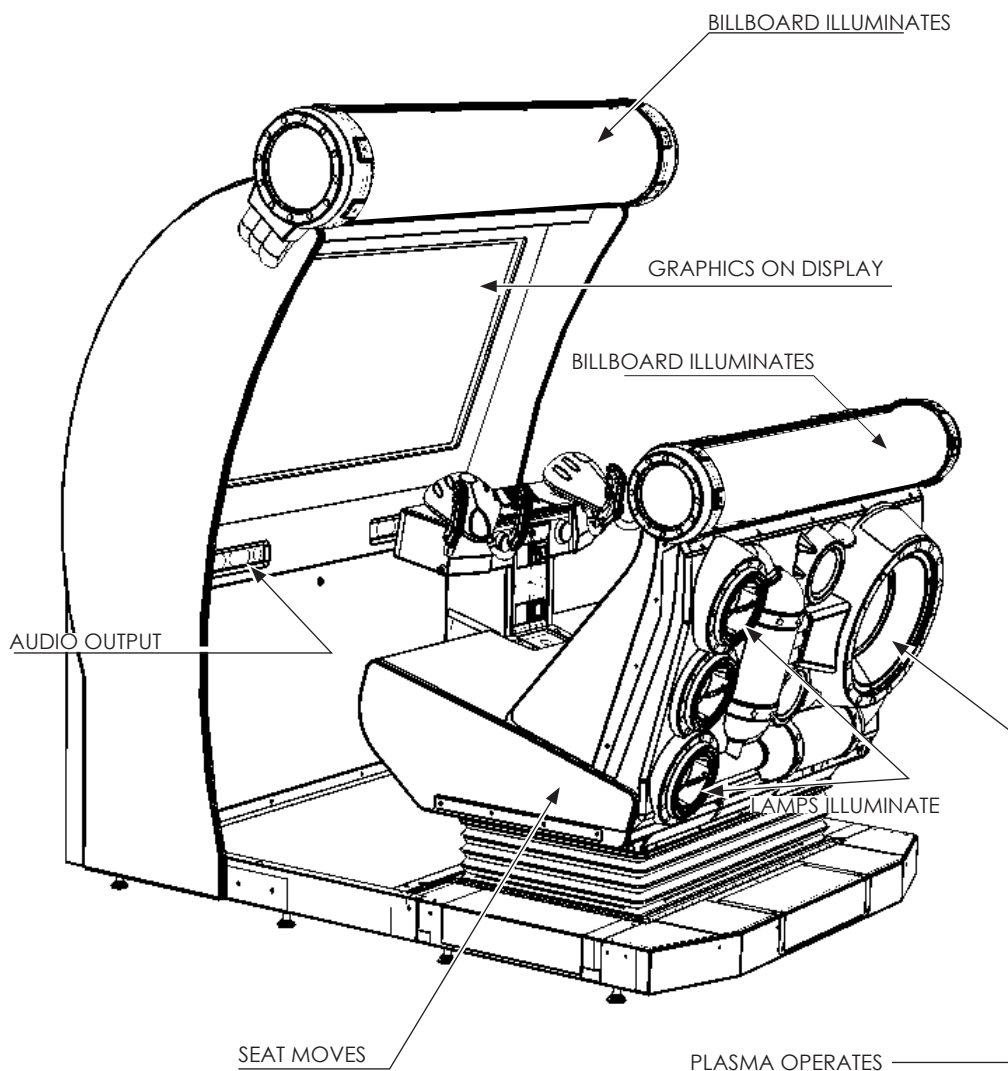

## 6-7 CONFIRMATION OF ASSEMBLY

Use the TEST MODE to check whether or not the product has been correctly assembled and whether or not everything operates normally.

### CAUTION

- **The seat moves during the initialization of the cabinet. Please wait and stand aside of the cabinet during this time. Do not touch the seat while it is initializing.**

- 1 Turn ON the power switch.
- 2 The Billboard and Rear Moulding LED's will illuminate along with the Plasma Disc.
- 3 The Gameboard logo is displayed on screen
- 4 The initialization screen appears on screen. Take precautions since the initialization operation will begin.
- 5 When the seat initialization is complete, the seat will move to it's set position and the advertising screen will appear on screen.
- 6 Press the TEST button to enter the SYSTEM TEST MENU screen. (See Chapter 9)
- 7 **MONITOR TEST screen**  
Select "MONITOR TEST" in SYSTEM TEST MODE to bring up the MONITOR TEST screen.  
The monitor is shipped from the factory pre-adjusted but you may use the MONITOR TEST screen to determine whether it need to be re-adjusted. If adjustment is needed, refer to the section of this manual under the section MONITOR LCD.
- 8 Select the "GAME TEST MODE" in the SYSTEM TEST MODE.
- 9 The initialization screen will reappear, again take precaution as the seat initialization will begin.
- 10 **INPUT TEST screen**  
Select "INPUT TEST" in the GAME TEST MODE to bring up the INPUT TEST screen, allowing you to test the input devices to verify operation.
- 11 **OUTPUT TEST screen**  
Select "OUTPUT TEST" in the GAME TEST MODE to bring up the OUTPUT TEST screen, allowing you to test devices such as lamps and LED's
- 12 **CONTROLLER ADJUSTMENT screen**  
Select "CONTROLLER ADJUSTMENT" in the GAME TEST MODE to bring up the CONTROLLER ADJUSTMENT screen, allowing you to calibrate the controllers. Select CALIBRATION and follow the on-screen instructions.

6-8 APPLYING WARNING LABELS (EPILEPTIFORM SEIZURES)

**⚠ CAUTION**

- The operator **MUST** apply the Epileptiform Seizure Label to this product. Failing to apply this label may result in the player/observer suffering from a photosensitive seizure. Warning the potential player/ observer of this before the start of a game may prevent such accidents.
- It is also important to apply the correct language label for each location. There are nine (9) different language labels - please apply the label which matches your location.

**STOP IMPORTANT**

Application of any warning labels must be placed in a location which is easy for the player/observer to read. Please follow the instructions below and apply the label in the location stated.

The Epileptiform Seizure label is supplied in 12 different languages. Please choose the label which matches your language location.

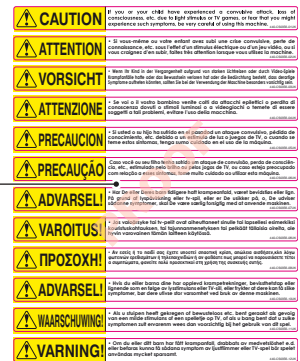

Apply the label centrally to the outer mask (do not apply it to the screen). This location is unobstructed and can be easily read by players.

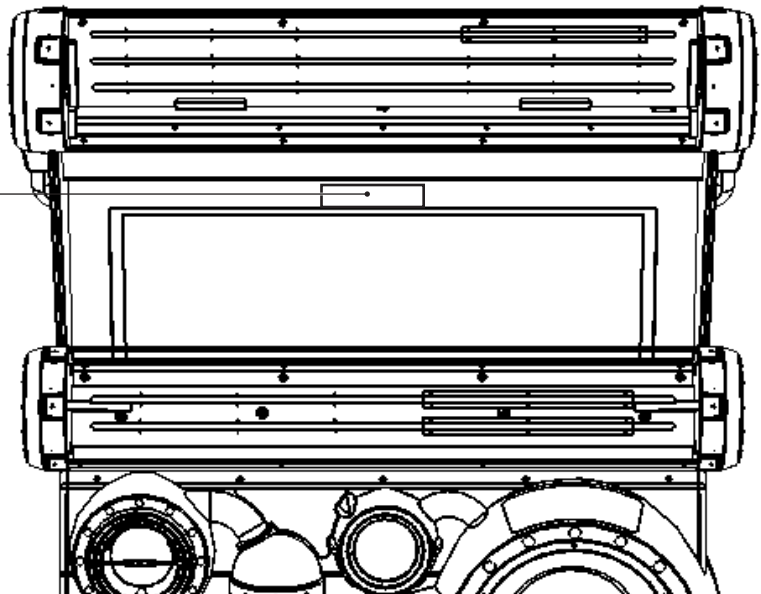



## **7** PRECAUTIONS WHEN MOVING THE MACHINE

### **WARNING**

- As used in these instructions, the term “moving” refers to moving of the product within the same building, store or facility. These instructions do not cover moving between different buildings, areas, stores or facilities, since diverse factors are involved, not only packaging but also loading onto transport vehicles, and securing the product in place during transport. To transport the product to a different building or store, contact the vendor where the product was purchased or the office indicated in these instructions. Or request that moving be done for you. This product is made up of parts that are of large size and heavy weight. Unless work is entrusted to someone with expertise in packaging and transport of such parts, a serious accident might occur.
- Even when the product is to be moved within the same building, store or facility, contact the point of purchase or the office indicated in these instructions if there will be level differences or narrow or low level entrances while moving. Or request that moving be done for you. Never disassemble the product in any way not covered in these instructions. Otherwise there could be a fire, electric shock and/or short circuit.
- Always disconnect the power cable before moving the product. If it is moved with the power cable connected, the cable could be damaged, causing fire or electric shock.
- A qualified electrician is required for moving product parts within a store and for changing indoor wiring. Do not have work performed by anyone who is not qualified. Otherwise there could be electric shock.
- Have work performed by site maintenance personnel or other qualified individuals. Do not allow people without proper knowledge and technical expertise to work on the product. Otherwise there could be an electric shock or other serious accident. Also, customers could be injured while operating the product.
- Do not try to move this product while it is still assembled. Always remove the Billboard and split the cabinets before moving.
- Because it is structurally difficult for exterior lighting to enter the cabinet, have auxiliary lighting available. Working within a dark environment can lead to accidents.
- For instructions on separation and disassembly of the cabinet, refer to Chapter 6 of this manual. Failure to follow the instructions given by this manual leaves a high risk of accidents such as electric shock occurring.
- Proceed with checks and tasks as indicated in these instructions. If instructions are not followed, or if tasks and/or checks are neglected, an electric shock or other very serious accident, even fatal accident, can occur. Also, customers could be injured while operating the product.
- Be careful not to damage wiring. Before separating parts that have wiring connections, disconnect the wiring connections, unravel wire bundles and undo fastenings. Only after that, remove fasteners (screws, nuts, etc.). If wiring becomes damaged, there could be an electric shock, short circuit or fire.

**⚠ WARNING**

- When inserting or removing a connector, always hold it by its main part. If you hold it by anything else while doing so, the connections between wire and connector terminal fixtures could be damaged; and there could be a short circuit or fire. There could also be poor connectivity.
- Do not move unit with the adjusters in contact with the floor. Otherwise parts might be damaged or deformed and there might be accidents.
- Whenever any fasteners (e.g. screws, nuts) have been lost, always use replacement fasteners with proper dimensions as specified in this manual. If fasteners of any other dimensions are used, it could cause damage and/or separation of parts that result in secondary accidents.
- Do not place the cabinet on inclines or uneven surfaces. This could result in the unit falling over.
- Check surroundings carefully while moving the unit. If you should get caught between the unit and a wall, for instance, there could be a serious accident.
- Have on hand a number of workers appropriate for each task that needs to be done. Make calculations by approximating that one worker can lift roughly 15 kg of weight. If an insufficient number of workers try to lift a heavy object, it could result in a worker stumbling and the object being dropped, crushing someone or something underneath. Workers could also injure their backs, etc.
- When lifting a heavy object, be sure to carefully consider the area where it will be lifted. If possible, lift the object by its handles or base. If weak fasteners or fragile parts are gripped, they could be damaged under the weight of the object, and this could result in a worker stumbling and the object being dropped, causing personal injury.
- Never disassemble the unit in ways other than those described in this manual. Doing so can cause accidents such as electric shocks, short circuits, and fires.
- Do not attempt to tilt the unit to fit it through narrow doorways. Moving the unit while it is tilted can result in an accident. It can also cause deformations and damage to parts, as well as deviations of fastening positions, which could result in accidents during operation.

**STOP IMPORTANT**

- If moving through a door or places that may become narrow, i.e corridors or places which have low ceilings such as an elevator, you should remove the billboard.

## CAUTION

- Do not push plastic parts or any part associated with the moving mechanism. Do not lift or support the product by any plastic part. Parts can be damaged, and fragments can cause injury.
- Do not push on or hold onto the LCD or controllers to move the unit. Doing so could break the parts and lead to people getting injured..
- Do not stack parts that have been separated or disassembled indiscriminately. The surface of the parts could be damaged or deformed. Significant deformations can result in improper operation and breakdowns.
- Do not lean separated or disassembled parts against a wall or other surface indiscriminately. The parts could be deformed. Accidents could also occur should the parts fall over.
- Do not hold onto the controllers to use as a lever or leverage. Doing so may cause damage resulting in injury to the player or impaired game play.

## IMPORTANT

- If the unit is moved over floor surfaces where there is carpet, decorative panel, etc., there might be friction or soiling.
- Movement by casters can damage the floor, depending on the floor material. Have a mat or thin plate available for moving casters. If rugs, for instance, have been laid out, remove them before moving.
- Be careful not to damage delicate parts as the rear seat moulding/ billboard end caps e.t.c whilst moving the product. Always push/pull the product levering from the bolted on metal parts or by the lower sections such as the base.
- Do not apply rope directly to the product's surface. Use protective material at locations where rope is applied taking care not to damage components attached to the machine.

## IMPORTANT

- The strength of this product's joints were not designed such that the product can be moved while assembled. Attempting to push on the cockpit, etc. to move the unit while assembled can result in damage, deformation, and misalignment of the joints. Abnormalities in the joints can result in improper operation or breakdown in internal mechanisms.

When moving across the floor, detach the rear cabinet, joint floor and front cabinet. If the height of the area in which the cabinet is to be moved changes it may be required to remove the Billboard. Refer to Chapter 6 and work in reverse order to reform disassembly

**7** PRECAUTIONS WHEN MOVING THE MACHINE

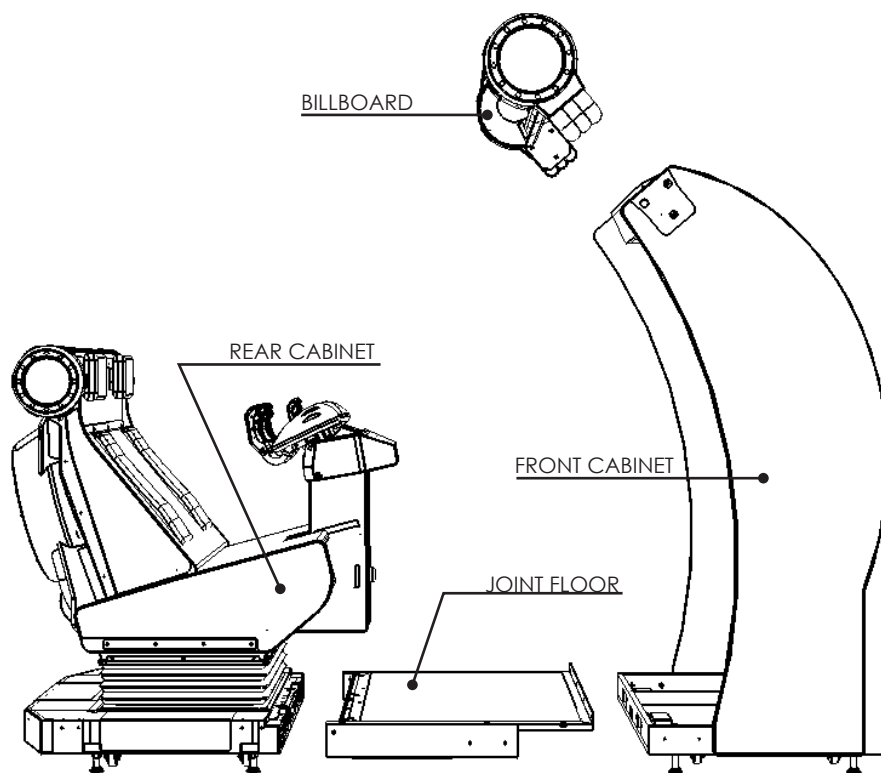

## 8 GAME DESCRIPTION



### 8-1 GAME OVERVIEW

“Dream Raiders” is a 2-Player “Ride” based casual shooting game.

Players sit on a moving seat and fire a machine gun.

The premise is that players enter the “Dream Machine” to experience different types of adventures of their choice and trying to score as high as possible for each “dream/adventure”.

It is possible to enjoy a maximum of 2 stages within a single game.

- Tier 1 - A selection out of 6 stage options
- Tier 2 - A selection out of 3 stage options (pending completions of Tier 1)

### 8-2 BASIC CONTROLS AND FUNCTIONS

Moving the controller will move the target sight on the screen.

Pulling the trigger fires a bullet.

Bullets are fired continuously as long as the trigger is held. You have unlimited ammunition.

## 8-3 GAME SCREENS

### SHARE MODE

**TARGET MAKER**  
HIGHLIGHT IMMINENT ENEMY ATTACK

**PLAYER 2**  
TARGETING SITE



**PLAYER 1**  
TARGETING SITE

**LIFE & SCORE GAUGE**  
WHEN LIFE DROPS TO ZERO IT'S DREAM OVER!

### INDEPENDENT MODE



**PLAYER 1**  
LIFE SCORE GAUGE

**PLAYER 2**  
LIFE SCORE GAUGE

## 8-4 LIFE GAUGE

The Life gauge is selectable between “Share” & “Independent” (In the test menu)

SHARE:

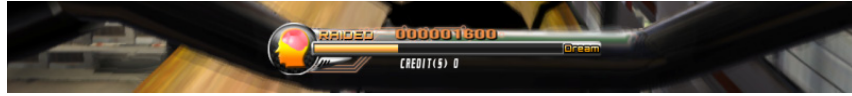

The Life gauge is unified into one.

It is possible to play the game with either 1 Player or 2 Players

There is no option to “Continue” by adding further credits should the player’s GAME OVER.

INDEPENDENT:

Each Player has his/her own life gauge, which depletes independently

There is an option to set “Continue” in the Test Menu



When attacked and received damage from an enemy, the life gauge drops.

GAME OVER (Displayed as “DREAM OVER”) conditions:

A) The player life gauge goes down to ZERO.

or

B) The player completes Tier 2

### ABOUT SCORING

Every enemy and collectable item hit in game will score

Life gauge left over at the end of the game adds up to total score

When you hit an enemy with a full life gauge, the score is multiplied by a factor of 10.

When you hit an enemy with a 50% or more life gauge, the score is multiplied by a factor of 5.

To score the most points, complete the stage without receiving any damage.



## 8-5 PLAYER DAMAGE

### IN SHARE MODE

Unified life gauge registers damage regardless of Player 1 or Player 2 error.



### IN INDEPENDENT

When a player receives damage like a enemy strike or missile in their specific zones, only the Player responsible in that damage zone will register a loss in life gauge.



PLAYER 1 HIT ZONE

PLAYER 2 HIT ZONE



## 8-6 STAGE SELECT SCREEN



### HIGHLIGHT:

The currently selected stage will be highlighted and also color-coded according to player controller.

### STAGE CONFIRMATION

#### 1P PLAY:

Select desired stage by moving the highlight box with controller. Pull trigger to confirm. In the event a selection is not made within the allocated time, a stage will be randomly selected.

#### 2P PLAY:

Select desired stage by moving the highlight box with controller. Pull trigger to confirm. In the event a selection is not made within the allocated time, a stage will be randomly selected from one of the highlighted boxes (if there is one - otherwise, a random stage will be selected out of the 6 or 3 choices).

Tier 1 - A selection out of 6 stage options

Tier 2 - A selection out of 3 stage options (pending completions of Tier 1)

## 8-7 RESULT SCREEN

### SCORE

This screen will display the total score accumulated for the completed tier.



### RANKING

A Rank will be given according to the score (out of 100)

### ABOUT RANKING

The default threshold marker score to pass to obtain “1ST” place is listed below for each stage:

MINE CART STAGE: 110000 Points  
RIVER RAFT STAGE: 80000 Points  
AIR STAGE: 80000 Points  
MOTORBIKE STAGE: 110000 Points  
SNOW STAGE: 80000 Points  
HORSEBACK STAGE: 120000 Points  
SUPERMAN STAGE: 110000 Points  
UFO STAGE: 120000 Points  
DRAGON STAGE: 110000 Points

If the cabinet is power cycled or enters Test Menu, the Ranking board resets to default

## 8-8 TIER 2 STAGES

### TIER 2 STAGES

After a certain point of the tier 2 stages, the game will not allow a second player to join in. If there is no second player present to begin with, the display which normally reads “Insert Coin” will display a message saying “PLEASE WAIT UNTIL NEXT GAME”

The point at which this occurs is:

SUPERMAN STAGE: After crossing the Bridge

UFO STAGE: When you enter Space

DRAGON STAGE: When leaving the cave and making a vertical climb

On average, these points are all around 40 seconds into the stage.

If there is a 2P game in progress at the time and one of the players should “Dream Over”, the game will also not allow the player to “Continue”. The screen shall look like this.



Screen when there is only a single person playing at start of game.



## 9 EXPLANATION OF TEST AND DATA DISPLAY

Perform tests and data checks periodically by manipulating the TEST Button and SERVICE Button in the cabinet. Follow the instructions in this chapter to conduct checks when the game machine is first installed, when money is being collected, or when the game machine does not operate properly.

Shown overleaf are the tests and screens to be used for different problems.

### **STOP** IMPORTANT

- **The details of changes to test mode settings are saved when you exit from TEST MODE by selecting EXIT from the system test mode menu. Be careful because if the power is turned off before that point, changes to the settings will be lost.**
- **Use with the specified settings. If settings other than those specified are used, inappropriate operations or malfunction may occur.**

In the SYSTEM TEST MODE, the main activities include checking RINGWIDE information and actions and the setting of coin/credit.

For details, see the GAME BD section of this manual.

Press the TEST Button to enter TEST MODE and bring up the SYSTEM TEST MENU screen.

Before using the product, enter SYSTEM TEST MODE and check to make sure that “COIN CHUTE TYPE” under “COIN ASSIGNMENTS” is set to “COMMON”; and “SERVICE TYPE” is set to “COMMON NETWORK SETTING”, “DHCP”, and “DISABLE”.

### **STOP** IMPORTANT

- **Adjust the sound to the optimum volume, taking into consideration the environmental requirements of the installation location.**

## 9-1 SWITCH UNIT AND COIN METER.

The SWITCH UNIT and COUNTERS are housed within the COINTOWER. To access these controls you will need to open the COIN door, the switches and counters can be found directly on the rear face of the Tower.

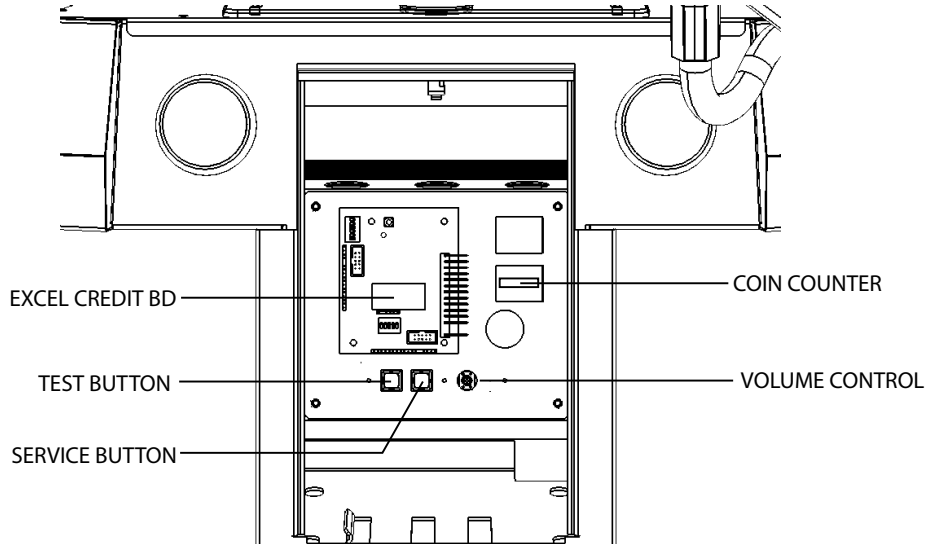

DEVICE	FUNCTION
TEST BUTTON	Press to enter TEST MODE - Also used to enter choices selected within TEST MODE
SERVICE BUTTON	Press for SERVICE CREDIT - Also used to scroll through TEST MENUs
COIN IN COUNTER	Counts inserted coins (£0.10 or \$0.10 = 1 count)
VOLUME CONTROL	Adjusts audio level

## 9-2 TEST MENU

### STOP IMPORTANT

The details of changes to Test Mode settings are saved when you exit from each Test Mode by selecting EXIT. Be careful because if the power is turned off before that point, changes to the settings will be lost.

SYSTEM TEST MODE can be used to check the information or the operation of RINGWIDE, adjust Monitor color, and perform coin/credit settings.

- 1 Press the TEST Button after powering on the unit to display the following SYSTEM TEST MODE.

For further details, see the RINGWIDE service manual. If you do not have a RINGWIDE service manual with this product, there is a copy available for download on the SEGA AMUSEMENTS website. ([www.segaarcade.com](http://www.segaarcade.com))

## 9-3 GAME TEST MODE



GAME TEST MODE

From the SYSTEM TEST MODE -

Using the SERVICE BUTTON to select GAME TEST MODE and press the TEST BUTTON to enter

### BOOKKEEPING

Inspects and sets up BOOKKEEPING.

### INPUT TEST

Checks the input of the I/O.

### OUTPUT TEST

Checks the output of the I/O.

### GAME ASSIGNMENTS

Configures all settings related to the game.

### SEAT MOTION TEST

Checks operation of the Seat Motion..

### CONTROLLER ADJUSTMENT

Checks Gun alignment and calibration.

### BACKUP DATA CLEAR

Erases all types of Game recordings, such as: TOTAL COINS IN, TOTAL CREDITS, GAME TIMES etc.

### EXIT

Returns to the "SYSTEM TEST MODE" when selected.

## 9-4 BOOKKEEPING

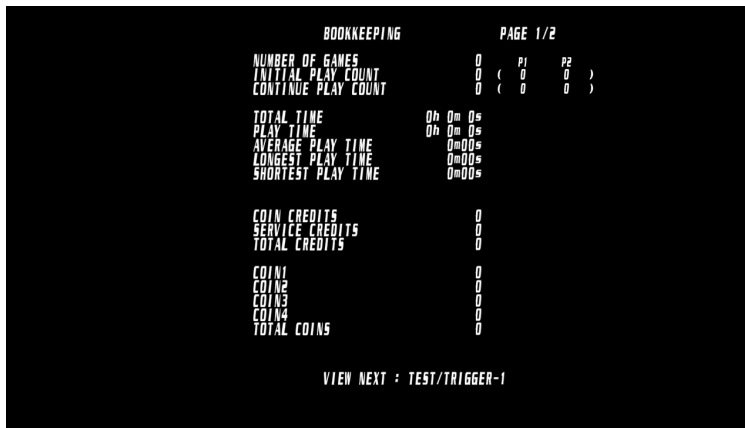

BOOKKEEPING SCREEN 1

From the GAME TEST MODE screen -

Using the SERVICE BUTTON to select BOOKKEEPING and press the TEST BUTTON to enter

NUMBER OF GAMES		Overall total amount of game plays.
INITIAL PLAY COUNT		Number of initial plays
CONTINUE PLAY COUNT		Number of continue plays (only shows when applicable)
TOTAL TIME		Total active time.
PLAY TIME		Total playtime.
AVERAGE PLAYTIME		Average playtime for one game to "Gameover" or "Continue".
LONGEST PLAYTIME		Longest playtime for one game to "Gameover" or "Continue".
SHORTEST PLAYTIME		Shortest playtime for one game to "Gameover" or "Continue".
COIN CREDITS	-	Total number of coins inserted into the machine in game mode.
SERVICE CREDITS	-	Total number of times the service credit button was pressed in game mode.
TOTAL CREDITS	-	Total number of credit in game mode.
COIN1-4	-	Number of "COIN IN" registered for the particular coin slot.
TOTAL COINS	-	Total number of "COIN IN" for all coin slots.

Press the TEST button to view the BOOKKEEPING SCREEN 2

### TIME HISTOGRAM

A histogram of displaying game-play time per credit.

Press the TEST button to return to the GAME TEST MODE screen.



BOOKKEEPING SCREEN 2



## 9-5 INPUT TEST

From the GAME TEST MODE screen -

Using the SERVICE BUTTON to select INPUT TEST MODE and press the TEST BUTTON to enter



INPUT TEST SCREEN

Displays the Input and Input status of each machine component.  
“ON” appears if there is an input signal being detected, if not then “OFF”

CONTROLLER -1	Value when the controller moves for player-1
CONTROLLER -2	Value when the controller moves for player-2
TRIGGER-1	Input of trigger for player-1
TRIGGER-2	Input of trigger for player-2
START-1	Input of start buttons for player-1
START-2	Input of start buttons for player-2
MOTION STOP	Input of motion stop buttons
TEST	Input of test switch or SW1
SERVICE	Input of service switch or SW2

Press TEST and SERVICE to EXIT and return to GAME TEST MODE screen



## 9-6 OUTPUT TEST

From the GAME TEST MODE screen -

Using the SERVICE BUTTON to select OUTPUT TEST MODE and press the TEST BUTTON to enter



OUTPUT TEST SCREEN

Checks the status of the output signals for diagnostic purposes

START-1/2 LAMP	ON/OFF of START button lamp
RECOIL-1/2	ON/OFF of controller feedback
BLOWER LEVEL	Blower strength value OFF / 1 - 7
LED-1/2/3	LED COLOUR OFF/RED/GREEN/BLUE/YELLOW/MAGENTA/CYAN/WHITE

Select EXIT and press TEST return to GAME TEST MODE screen.

## 9-7 GAME ASSIGNMENTS

From the GAME TEST MODE screen -

Using the SERVICE BUTTON to select GAME ASSIGNMENTS and press the TEST BUTTON to enter

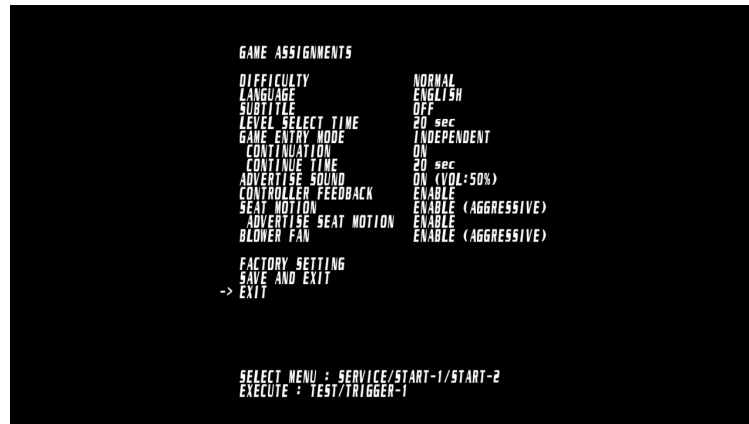

GAME ASSIGNMENTS

**DIFFICULTY** (default: NORMAL)

This can be adjusted to modify game difficulty.

EASIEST / VERY EASY / EASY / NORMAL / HARD / VERY HARD / HARDEST

**LANGUAGE**

Language settings depends on the region.

(Region EXP:) ENGLISH(default) /SPANISH /RUSSIAN /ITALIAN /FRENCH /TURKISH

(Region USA:) ENGLISH(default) /SPANISH

**SUBTITLE** (default: OFF)

Set the subtitle ON/OFF.

**LEVEL SELECT TIME** (default:20 sec)

Wait time to select stage (seconds)

**GAME ENTRY MODE** (default:SHARE)

Decides how to start the game

**SHARE:** A single game played by 1 or 2 players. Both players “SHARE” a single life gauge and try to complete a chosen stage before the life gauge depletes. Note: There is no continue game play option in this mode. (Please refer to Chapter 8-3, 8-4 and 8-5 for in depth explanation)

**INDEPENDENT:** A game played by Player1 or Player 2 independently of each other. Each player has their own life gauge and try to complete each stage before their life gauge depletes. The option for a player to continue the game is enabled in this mode. (Please refer to Chapter 8-3, 8-4 and 8-5 for in depth explanation)

**CONTINUATION** (default:OFF)

Applicable if “GAME ENTRY MODE” is “INDEPENDENT”.

Sets the continuation.

OFF / ON

**CONTINUE TIME** (default:20 sec)

Applicable if “GAME ENTRY MODE” is “INDEPENDENT” and “CONTINUATION” is “ON”.

Wait time to continue (seconds)

**ADVERTISE SOUND (default:ON(50%))**

Adjusts the sound volume during the advertise demo mode.  
 Percentage is the sound volume ration from main volume.  
 OFF / ON(25%) / ON(50%) / ON(75%) / ON(100%)

**CONTROLLER FEEDBACK (default: ENABLE)**

Sets the controller feedback.  
 ENABLE / DISABLE

**SEAT MOTION (default:ENABLE(AGGRESSIVE))**

Allow the motion movement and sets the strength.  
 ENABLE(AGGRESSIVE) /ENABLE(GENTLE) / DISABLE

**ADVERTISE SEAT MOTION (default: ENABLE)**

Applicable if “SEAT MOTION” is “ENABLE”.  
 Allow the motion movement in advertise demo mode.  
 ON / OFF

**BLOWER FAN (default:ENABLE(AGGRESSIVE))**

Allow the blower fan control and sets the strength.  
 ENABLE(AGGRESSIVE) /ENABLE(GENTLE) / DISABLE

**FACTORY SETTINGS**

Returns all settings within “GAME ASSIGNMENTS” to the default settings when you press TEST/TRIGGER-1.

**SAVE AND EXIT**

Saves the settings and returns to the GAME TEST MODE screen when you press TEST/TRIGGER-1.

**EXIT**

Returns to the “GAME TEST MODE” screen without saving any settings changes when you press TEST/TRIGGER-1.

## 9-8 SEAT MOTION TEST

### CAUTION

- Take extra care when operating the START/TRIGGER/TEST switches in MOVING TEST and RECALIBRATE TEST. The SEAT will move during these tests.

From the GAME TEST MODE screen -

Using the SERVICE BUTTON to select SEAT MOTION TEST and press the TEST BUTTON to enter



SEAT MOTION TEST

Seat calibration will commence when you enter this menu for the first time.

You can cancel the calibration by pressing TEST switch within 5 second after calibration sequence started.

#### PITCH/ROLL VALUE

These values must show between “2000H” to “E000H”.

#### STATUS

OK

- It is normal.

ERROR: NO DRIVE BOARD FOUND

- The driver board (PCB) was not found.

ERROR: DISCONNECTED

- A serial cable is not connected.

ERROR: INITIALIZATION FAILED

- The motion system could not be started.

ERROR: VOLUME POT UNRESPONSIVE

- A volume value potentiometric has not responded.

ERROR: OUT OF VOLUME RANGE

- A volume value was abnormal.

ERROR: ENCODER ERROR

- The drive board could not process the command.

ERROR: OVER CURRENT

- There is an over current of power detected on the PCB.

ERROR: OVERHEAT

- The motion system has overheated.

ERROR: NOT INITIALIZED

- The motion system has failed to attempt initialization.

The motion system will stop if/when ever an error message appears.

#### MOVING TEST

You can check the seat direction and amount.

CENTER / LEFT / RIGHT / UP / DOWN

***The seat will move immediately when you change the value. Take care when operating the START/TRIGGER/TEST switches in MOVING TEST.***

#### RE CALIBRATE

Initializes the seat motor and calibrate it again.

Calibration sequence starts when you press TEST/TRIGGER-1.

You can cancel the calibration by pressing TEST switch within 3 second after calibration sequence started.

#### EXIT

Return to the “GAME TEST MODE” screen when TEST/TRIGGER-1 is pressed.

## 9-9 CONTROLLER ADJUSTMENT

From the GAME TEST MODE screen -

Using the SERVICE BUTTON to select CONTROLLER ADJUSTMENT and press the TEST BUTTON to enter

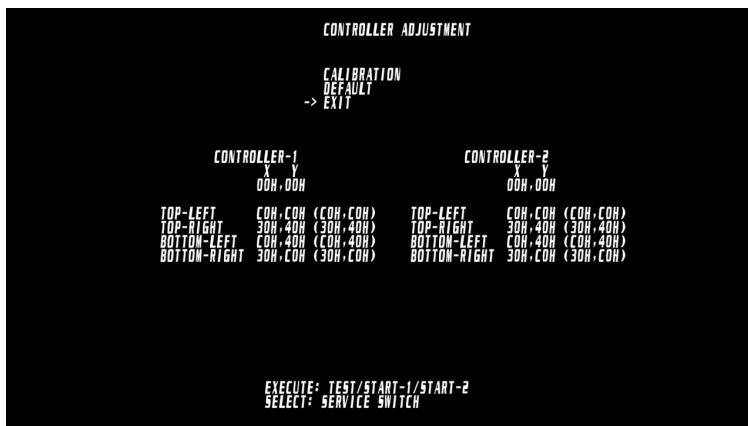

CONTROLLER ADJUST

### CALIBRATION

Press “Start” button of relevant controller to commence controller calibration.

### DEFAULT

Reset to default value.

### EXIT

Return to GAME TEST MODE screen

### INFORMATION ON THE DISPLAYED VALUES

- Top-Left, Top-Right, Bottom-Left and Bottom-Right represent each corner of the screen-space.
- It is displayed per controller.
- Each corner is represented in a value between 00H to FFH
- The first set of figures show the current calibration value of the particular corner via the controller.
- The second set of figures (in brackets) show the SAVED calibration value of the particular corner via the controller.

## HOW TO CALIBRATE CONTROLLERS



Aim the controller to “\* SHOOT HERE” and shoot using a trigger.



Shoot each corner according to instructions displayed.

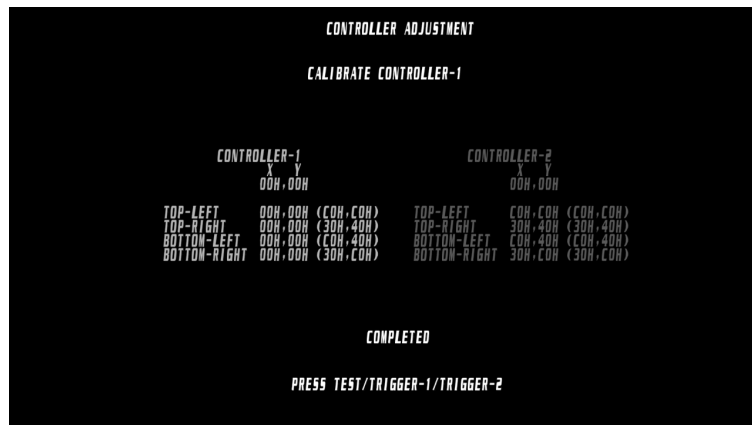

You return to controller adjustment menu when you press test or clasp the trigger after calibration.

## 9-10 BACKUP DATA CLEAR

From the GAME TEST MODE screen -

Using the SERVICE BUTTON to select BACKUP DATA CLEAR and press the TEST BUTTON to enter



BACKUP DATA CLEAR

Select this option to Initialize and clear existing bookkeeping data including credits/income data when you choose “YES” using SERVICE/START-1 and press TEST/TRIGGER-1.

When the command is executed, “COMPLETED” or ”CANCELLED” is shown.  
Return to the menu by pressing TEST.

EXIT

Enters into SYSTEM TEST MODE by pressing the TEST/TRIGGER-1.

## 9-11 TEST DEFAULT VALUES

### GAME ASSIGNMENTS (EXP/USA)

DIFFICULTY	NORMAL
LANGUAGE	ENGLISH
SUBTITLE	OFF
LEVEL SELECT TIME	20
GAME ENTRY MODE	SHARE
CONTINUATION	OFF
CONTINUE TIME	20
ADVERTISE SOUND ON	(50%)
CONTROLLER FEEDBACK	ENABLE
SEAT MOTION	ENABLE(AGGRESSIVE)
ADVERTISE SEAT MOTION	ENABLE
BLOWER FAN	ENABLE(AGGRESSIVE)

### CONTROLLER

TOP-LEFT	C0H, C0H
TOP-RIGHT	30H, 40H
BOTTOM-LEFT	C0H, 40H
BOTTOM-RIGHT	30H, C0H



## 10 CONTROLLER UNIT(S), SWITCHES AND BUTTONS

### WARNING

- When working with the product, be sure to turn the power off. Working with the power on may cause an electric shock or short circuit.
- Be careful not to damage the wires. Damaged wires may cause an electric shock, short circuit or present a risk of fire.
- Exercise due caution in performing soldering work. If soldering iron is handled carelessly, there could be fires or burns.

### CAUTION

- When fastening plastic parts, be careful not to tighten screws or nuts excessively. If these are tightened to excess, parts could be damaged, resulting in injuries from fragments, etc.
- After the unit has been disassembled and reassembled again, check carefully that the unit has been reassembled correctly.
- Be sure to inspect the outer covers on both gear and hand brake units.
- Assemble so that there is no gap between the L and R covers. If there is a gap or rattling, the players could get fingers or hands caught, resulting in injury.

### IMPORTANT

- Once the product has been disassembled, use slack preventive agent (product No. : 090-0012-N). Coat screws with suitable amounts of this agent and then tighten them. If this agent is not used, the product might start rattling or come apart.
- Use the slack preventive agent prescribed in these instructions. If any other agent is used, there could be chemical changes that inhibit the use of screws and part surfaces could be damaged.
- Be careful not to damage or lose small parts or screws.
- When a part has been replaced, be sure to always make adjustments and check conditions in Test Mode.

## STOP IMPORTANT

Be sure to perform volume's move value setting in the INPUT ASSIGNMENTS in the Game Test Mode after replacing or adjusting the Volume.

### 10-1 ADJUSTING/REPLACING THE VOLUME POT

- 1 Turn off the power.
- 2 Remove the 3 screws from the undersides of the Controller.

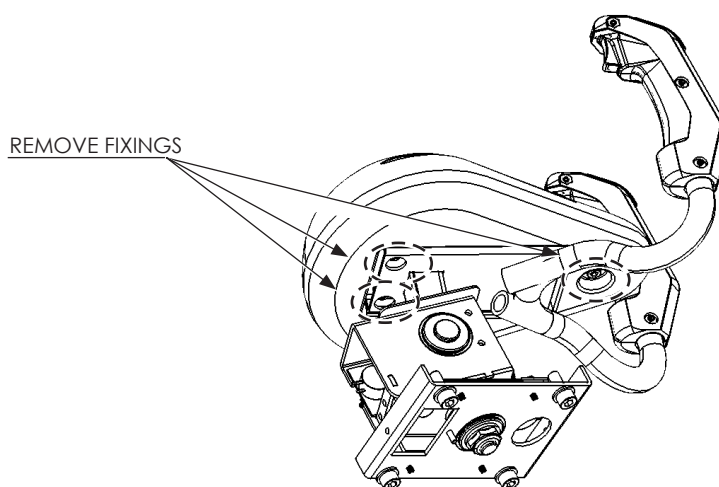

- 3 Carefully remove the Controller Cover to reveal the Volume Pots for adjusting.

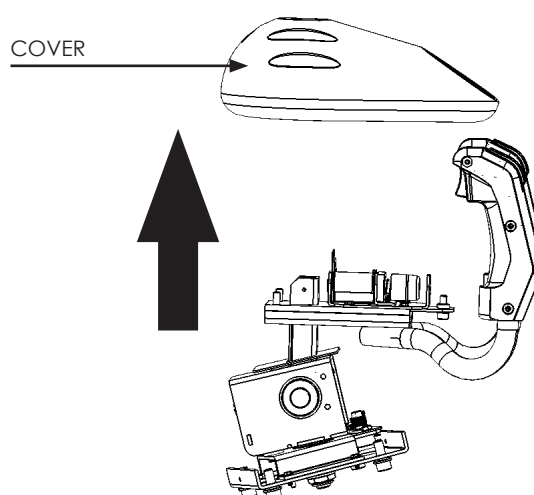

## ADJUSTMENT PROCEDURE

- 1 Apply this procedure to both Horizontal and Vertical Volume Pots. Loosen the 2 screws that secure the VR Bracket and move the VR Bracket to adjust the angle and condition of the gear alignment.

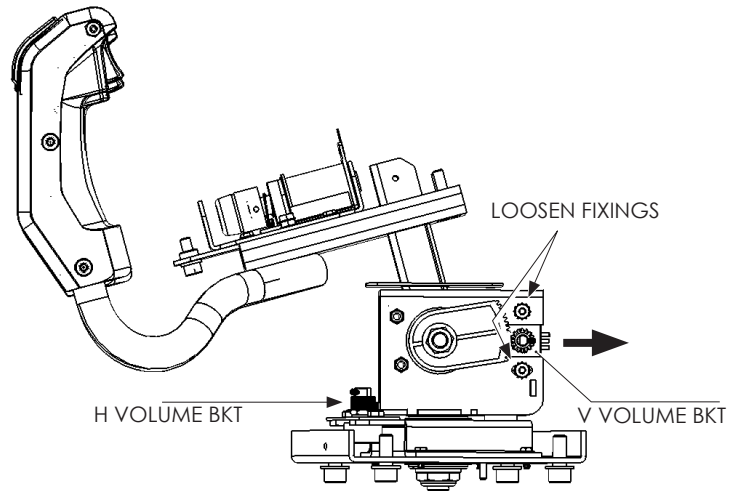

- 2 Locate the central position of the pot by turning the pot in both clockwise and counterclockwise positions. Once a central position of the pot has been determined, straighten the handle so that the gear is positioned horizontally. Slide the pot into position engaging the gears.
- 3 Tighten the 2 screws and secure the VR Bracket and refit the cover.
- 4 Check to make sure the value on the Input Test screen is within the range  $80H \pm 8H$  when the steering unit is in the straight position.

## REPLACEMENT PROCEDURE

This procedure requires the following tools: Phillips screwdriver for the M4 screws, 1.5 mm hexagonal wrench, 11-12 mm monkey wrench, nipper, cutter, wire stripper, soldering iron, industrial dryer and heat-shrinkable tube.

- 1 Remove the connectors.
- 2 Remove the 2 screws securing the VR Bracket and remove the entire Bracket and V.R. (See previous instruction)
- 3 Loosen the 1 hexagon socket screws on the Gear Holder and remove the Gear Holder.
- 4 Remove the nut securing the VR Bracket, then separate the Volume from the VR Bracket and replace it.
- 5 Check to make sure the value on the Input Test screen is within the range  $80H \pm 8H$  when the steering unit is in the straight position.

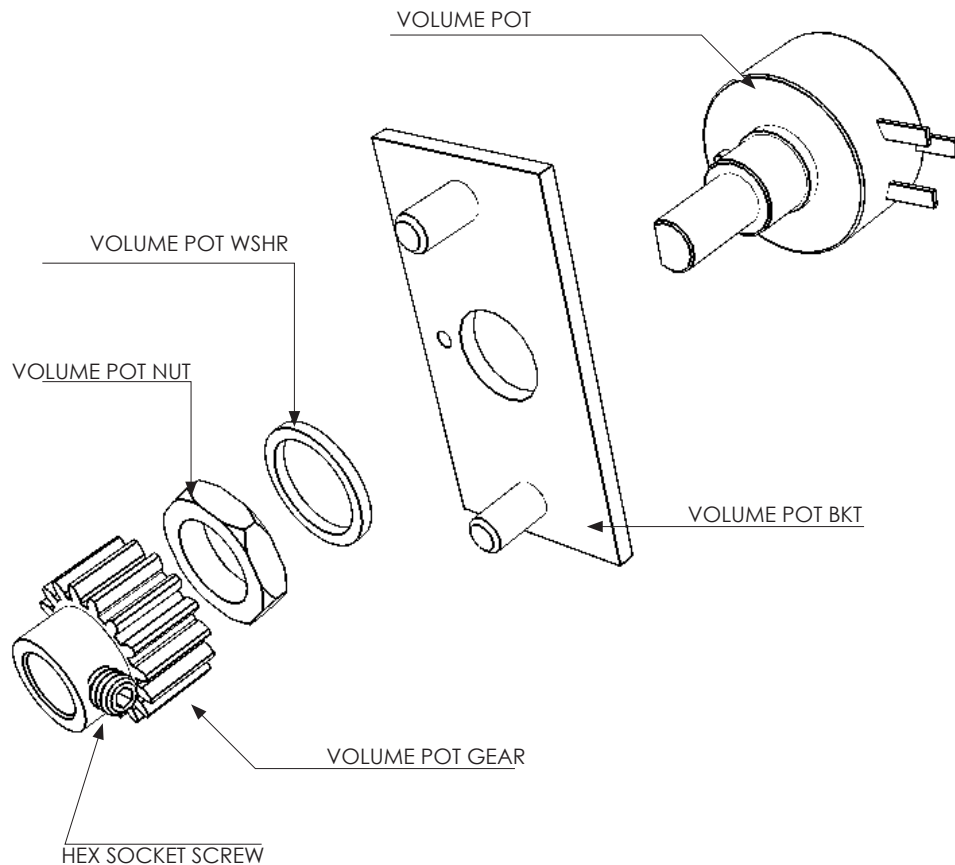

---

**6** The wire connected to the volume pot will be reused. Use a tool such as a pair of snips or cutters to remove the old heatshrink tubes which cover the contacts.

---

**7** Use a soldering iron to melt the solder and separated the wires from the old volume pot. Be very careful when using a soldering iron.

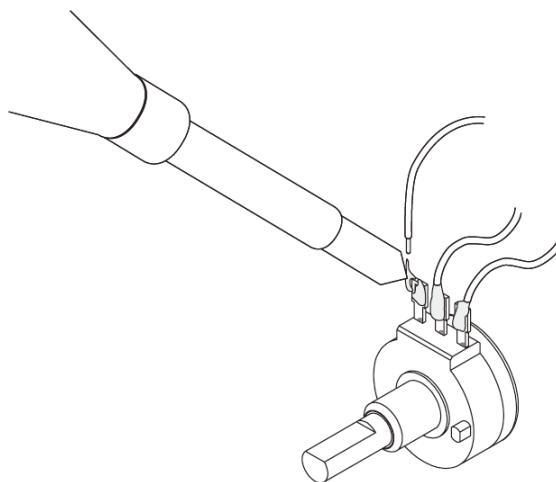

---

**8** If the exposed conductive wire at the end is less than 5mm, use a tool such as a wire stripper or cutter to cut the wire insulation back to a workable length. Place new sleeving over the wire before resoldering them to the pot.

---

**9** Once soldered, cover the bare contacts with the sleeving. If heatshrink is used, apply heat from an appropriate hot air blower to shrink the sleeving tightly over the contacts.

---

**10** Reassemble the pot to the pot bracket by working in reverse order of these instructions. Refer to the POT VOLUME ADJUSTMENT section of this manual.

## 10-3 GREASING

### STOP IMPORTANT

- Be sure to use the designated grease. Using undesignated grease can cause parts damage.
- Do not apply grease to locations other than as specified. Doing so may create a risk of operational problems and deterioration of parts.
- The designated periods for greasing serve only as a guide. Whenever there are squeaks or other anomalies, apply grease at designated locations.

Use spray grease once every three months to grease up the gear mesh portion of the constituent parts.  
Use "Grease Mate" (part number 090-0066) for the spray grease.

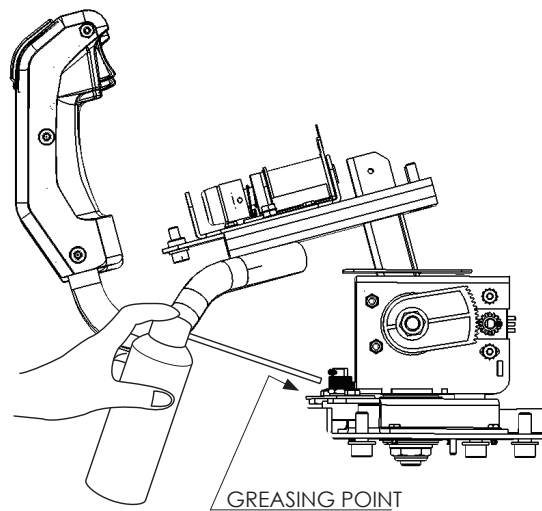
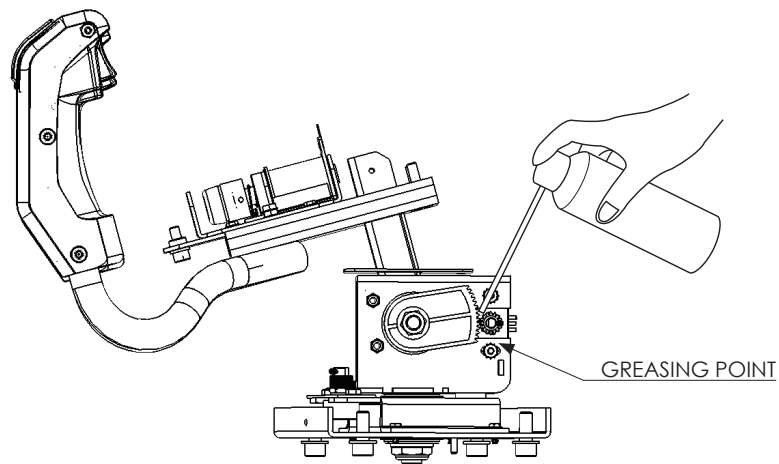

## 10-4 START BUTTON ASSY

### WARNING

- When working with the product, be sure to turn the power off. Working with the power on may cause an electric shock or short circuit.
- Be careful not to damage the wires. Damaged wires may cause an electric shock, short circuit or present a risk of fire.

If the start switch input does not function correctly on the INPUT TEST screen, the switch may need to be replaced. To carry out this maintenance, you must first remove the start button unit. For this task, you will need a tamper proof wrench (for M4 screws),

### Start Button Removal

- 1 Turn the power OFF
- 2 Unlock and open the coin door in order to gain access to the rear of the START BUTTON ASSY.
- 3 Reach into the COIN TOWER and grasp firmly with one hand the switch and lamp housing which is connected to the back of the button. Gently pull to remove.

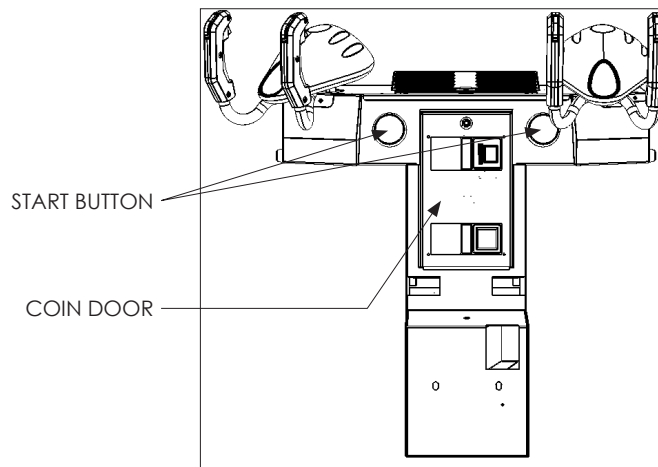

- 4 Using a button wrench or Box Spanner, clamp the nut on the rear side of the button and loosen. Unscrew the rest by hand and remove the button nut.
- 5 After the Re-installation of the Start Button, be sure to check the INPUT TEST in the Game Test mode to determine it's correct operation.

# 11 GRAPHICS DISPLAY

## 11-1 SAFETY PRECAUTIONS WHEN HANDLING THE MONITOR

### WARNING

#### Responding to breakdown or abnormality

- If smoke or a strange odor appears, immediately unplug the power cable from the power source.

Continuing to use the product may cause a fire or an electric shock. Ensure that smoke is no longer emitted, and contact the point of purchase.

- If nothing displays on the screen, immediately unplug the power cable from the power source.

Continuing to use the product may cause a fire or an electric shock. Contact the point of purchase and request an inspection.

- If water or a foreign object enters the monitor's interior, immediately unplug the power cable from the power source.

Continuing to use the product may cause a fire or an electric shock. Contact the point of purchase and request an inspection.

- If the monitor is dropped or the cabinet is damaged, immediately unplug the power cable from the power source.

Continuing to use the product may cause a fire or an electric shock. Contact the point of purchase and request an inspection.

#### During operation

- Do not repair, reconstruct, or disassemble the monitor.

The monitor's interior contains high voltage parts. A fire or an electric shock could result.

For inspections, adjustments, and repair of the monitor's interior, request work from the point of purchase.

- Do not insert foreign objects.

If metal objects or flammable materials such as paper are inserted into the interior through ventilation openings or other apertures, an electric shock could result.

- In the event of a thunder storm, do not touch the product or the power cable. An electric shock could result.

- Make sure to perform appropriate adjustments. Do not operate the product when the screen is flickering, distorted, or experiencing other abnormalities. Images from an improperly adjusted screen could cause players and other customers to experience dizziness, headaches, and other ailments.



## 11-2 CLEANING THE SCREEN SURFACE

### CAUTION

- Use a soft, dry cloth (flannel-type) to wipe away dirt. Do not use materials such as coarse mesh gauze.
- Alcohol (ethanol) is the recommended solvent for removing dirt. When using a cleaning agent, follow the precautions below.
  - Dilute neutral cleaning agents for home use with water. Soak a soft cloth in the solution, and wring it thoroughly before wiping the screen.
  - Do not use abrasive cleaning agents or powders, or cleaning agents containing bleach.
  - Do not use alkaline cleaning agents such as glass cleaners, or solvents such as thinners.
- Do not scrub or scratch the screen surface with abrasive materials such as brushes or scrub brushes.

**CLEAN THE SCREEN DAILY.**

## 11-3 ADJUSTMENT METHOD

### **STOP** IMPORTANT

All adjustment values are set accurately at the time of shipping from the factory. Do not readjust these values needlessly or apply adjustments not specified in this manual. The display may not appear properly if the values are incorrect.

### CONTROL - ADJUSTMENT PROCEDURE

This sections explains basic control procedures for making adjustments using the buttons on the 'Monitor Adjustment Board'

This Adjustment Board, and the Monitor Power Supply are located behind the Rear Door.

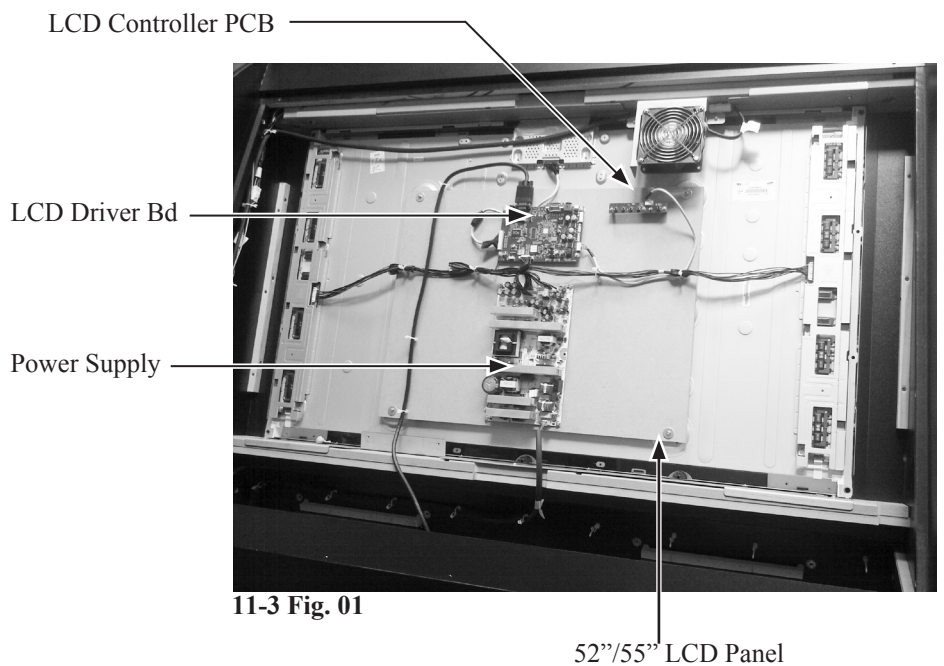

11-3 Fig. 01

52"/55" LCD Panel

## 11-3 ADJUSTMENT METHOD

### Button Names and Functions

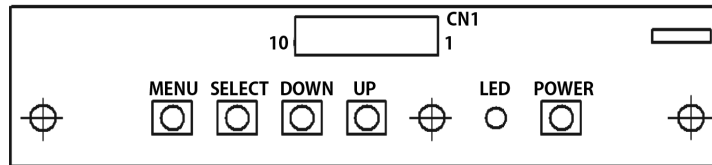

11-3 Fig. 02

**MENU:** Turn the Picture Menu display ON and OFF.

**SELECT:** Gains entry to the Item selected in the menu. (Highlights in Yellow when selected)  
Exits the Item adjustment. Any changes made during this operation are actioned.

**DOWN:** Moves the cursor (Black Bar) down to select a menu item.  
Decrease the value of, or change, a selected menu item.

**UP:** Move the cursor (Black Bar) up to select a menu item.  
Increase the value of, or change, a selected menu item.

**LED:** LED illuminates green: Monitor is operating.  
LED flashes red: Power is off.

**POWER:** Turns the LCD Display ON and OFF. (Usually, it's not necessary to operate.)

## 11-3 ADJUSTMENT METHOD

### On-Screen Display (OSD)

Press the MENU Button while the OSD is not displayed to bring up the Picture Menu.  
On the Picture Menu, it is possible to perform various screen adjustments.

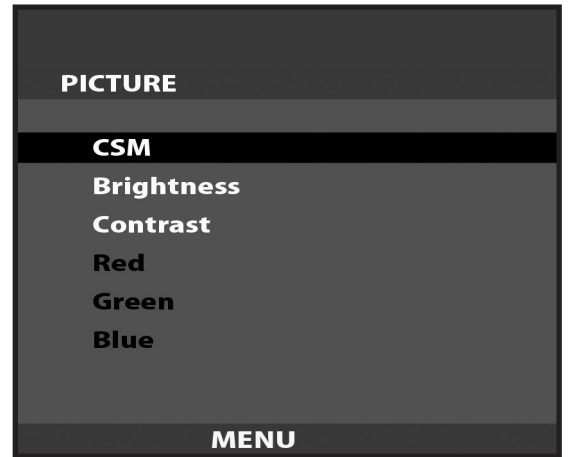

11-3 Fig. 03

Use the UP and DOWN Buttons to move the 'Black Bar' to the item you want to adjust.  
After selecting the desired item, pressing the SELECT Button will extend the MENU Screen and allow adjustments to be changed.

Within each item, press the SELECT Button to exit the adjustment screen. The adjustment values at this time will be saved simultaneously.

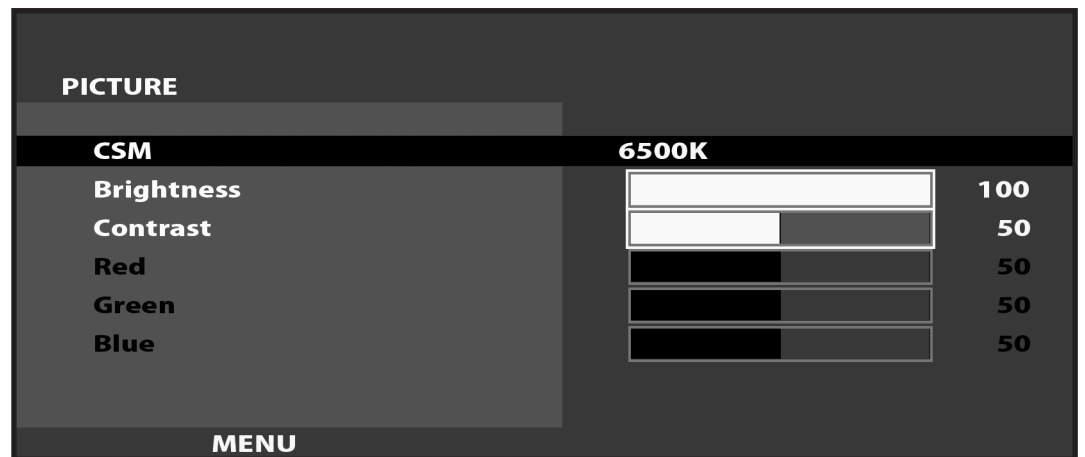

11-3 Fig. 04

The current options are set at :

CSM	-	6500K
Brightness	-	100
Contrast	-	50

## 11-3 ADJUSTMENT METHOD

### On-Screen Display (OSD) <continued>

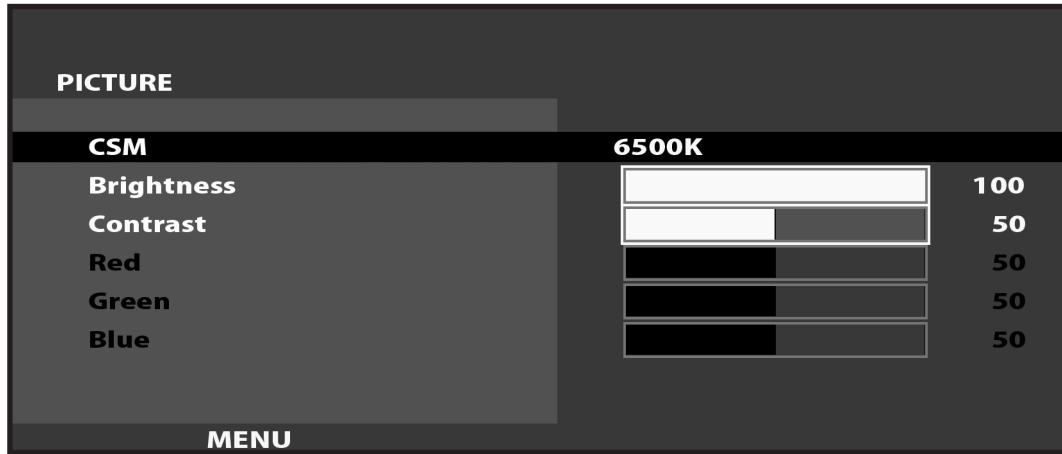

11-3 Fig. 06

### Available Settings

CSM (Selects Operation Mode)  
Selection available - 6500K - 9300K - USER

BRIGHTNESS (Adjust Brightness)  
Adjust screen Brightness. - Values: 0 - 100  
(0" being the darkest setting, and "100" being the brightest)

CONTRAST (Adjust Contrast)  
Adjust Contrast level. - Values: 0 - 100  
(0" having the least amount of difference between light and dark, and "100" having the most)

NOTE : The Red, Green, and Blue adjustments are unavailable in the Mode of Operation selected on the Screen shown in 11-3 Fig. 06. These adjustments can only be made is the CSM option is set to 'User'.

## 12 COIN HANDLING

### Handling the Coin Jam

If the coin is not rejected when the REJECT button is pressed, open the coin chute door and open the selector gate. After removing the jammed coin, put a normal coin in and check to see that the selector correctly functions.

12

COIN HANDLING

### 12-1 CLEANING THE COIN SELECTOR

#### STOP IMPORTANT

- Remove and clean smears by using a soft cloth dipped in water or diluted chemical detergent and then squeezed dry.
- Never apply machine oil, etc. to the Coin Selector.
- After cleaning the Coin Selector, insert a regular coin in the normal working status and ensure that the selector correctly functions.

The Coin Selector should be cleaned once every 3 months.  
When cleaning, follow the procedure below:

- 1 Turn the power for the machine OFF. Open the Coin Chute Door
- 2 Remove the Coin Selector from the Coin Chute Door
- 3 Open the gate and dust off by using a soft brush (Small soft Paint Brush, etc.)

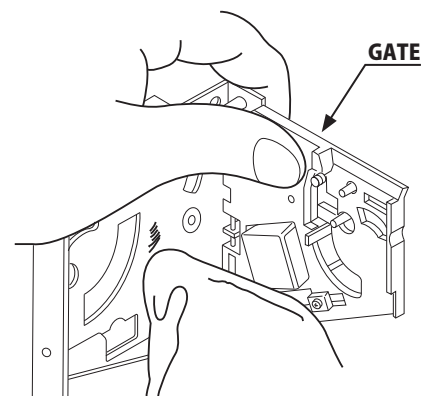

12-1 FIG 1

## CLEANING THE COIN SELECTOR (MECHANICAL).

**1** Remove and clean smears by using a soft cloth dipped in water or diluted chemical detergent and then squeezed dry.

**2** Remove the CRADLE.. When removing the retaining ring (E ring) be very careful so as not to bend the rotary shaft.

**3** Remove stain from the rotary shaft and shaft receiving portions by wiping off with a soft cloth, etc.

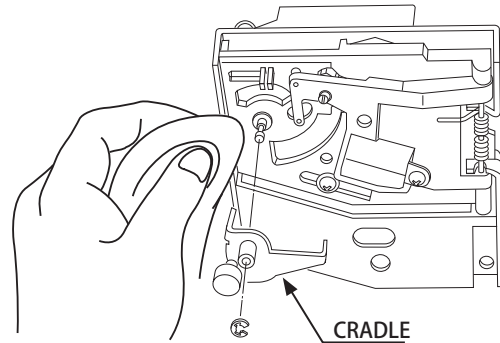

12-1 FIG 2

**4** After wiping off as per previous step, further apply a dry cloth to completely dry the Coin Selector.

### Coin Insertion Test

Once every month, when performing the Coin SW Test, simultaneously check the following:

Does the Coin Meter count satisfactorily?

Does the coin drop into the cashbox correctly?

Is the coin rejected when inserted while keeping the REJECT Button pressed down?

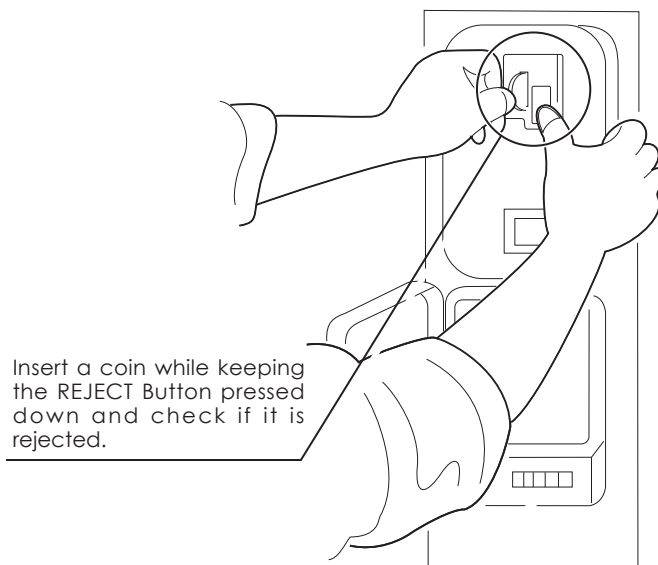

12-1 FIG 3

## CLEANING THE COIN SELECTOR (SR3) <continued>

12

COIN HANDLING

- 1 Remove and clean smears by using a damp soft cloth dipped in water. DO NOT use any diluted chemical detergent or cleansing agent as this will impair the workings of the component.

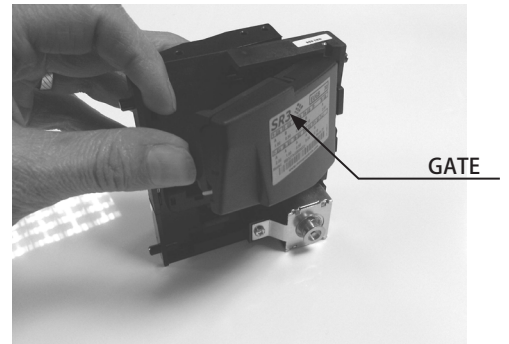

- 2 Open the reject gate to gain access to the rundown path.

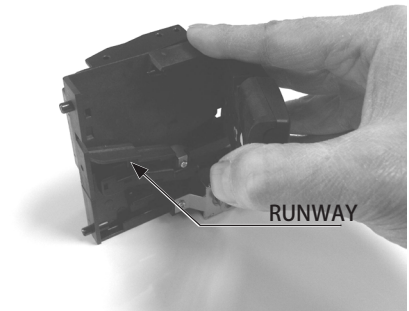

- 3 Remove the dirt and stains from the runway by wiping off with a soft damp cloth.



- 4 After wiping off as per previous step, further apply a dry cloth to completely dry the coin Selector.



## 12-2 FAULT FINDING

### Fault Finding

The following information is presented for customers' guidance in rectifying a fault but does not cover all possible causes.

All acceptors with electronic faults should be returned to an approved service centre for repair.

SYMPTOM	INVESTIGATE	POSSIBLE CAUSE
Acceptor does not work (all coins reject)	Connector	Poor Contact
		Loose Wire
	Power Supply	Not switched on
		Incorrect voltage
		Inadequate current
		Rise time too slow
	Inhibit all inputs	Acceptor Inhibited
	Accept gate	Gate not free or dislocated
	Accept channel	Obstruction
	Reject gate	Not fully closed
	LED on rear cover RED	EEPROM chksm error
		SR Sensor fault
		Credit opto fault
Credit sensor blocked		
Reject lever pressed		
LED on rear cover YELLOW	Reinstall power	
Poor Acceptance	Power Supply	Voltage less than 10v (Voltage drops when coil engages)
	Accept gate	Gate jam or dislocated
	Connector	Loose
	Coin rundown	Dirty
	Bank Select	Both banks enabled
Coin stick or jam in acceptor.	Accept channel	Acceptor dirty or may have some damage
	Accept gate	
	Reject gate	
A true coin type rejects	Label	Coin not programmed
No accept signal	Connector	Loose or broken wire
	Accept channel	Path dirty or obstructed

## 12-3 ADJUSTING THE PRICE OF PLAY (EXCEL)

### STOP IMPORTANT

- The price of play is determined by the configuration of switches located on either an EXCEL board or VTS board. The type of board used is determined by product location. Switch settings for both types of board remain the same.

This product comes equipped with a Money Controls SR3 Coin Acceptor. To adjust the price of play ALL credit settings are adjusted via the EXCEL CREDIT BOARD.

#### IMPORTANT!

The CREDIT SETTINGS within the SYSTEM TEST MODE must be set to 1 coin 1 credit to allow the CREDIT BOARD to function correctly.

The VTS BD has a built in Credit Board. This is controlled by 2 DIL Switches. These allow the operator to select the price of play, type of coin acceptor and region.

#### EXCEL Credit Board

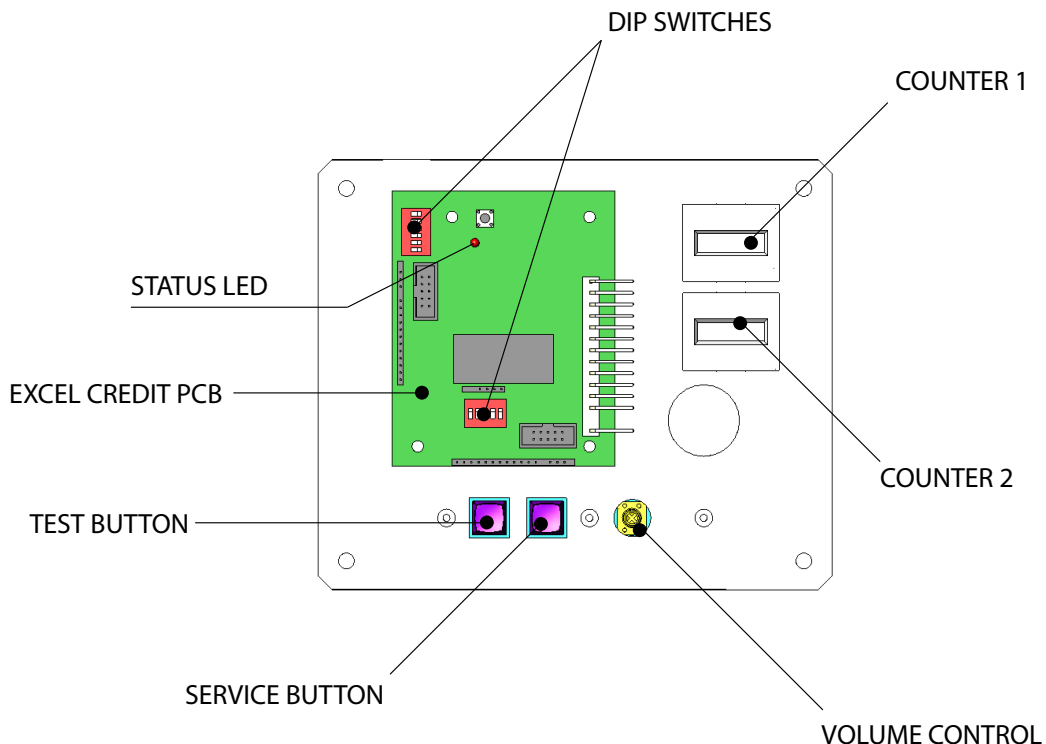

#### DIL SW3 (Regional Settings)

Adjust these switches to specify the type of Coin Acceptor used and currency.

Default = SW1&SW2 ON - NRI in parallel mode, Sterling.

#### TEST BUTTON

Provides access to the TEST MENU when pressed.

#### SERVICE BUTTON

Provides a SERVICE CREDIT when pressed

#### Status LED

Flashes when functioning.

#### CHANNEL 1

To Coin Acceptor (SR3 TYPE.)

#### DIL SW1 (credit settings)

Adjust to required price of pay.

#### VOL CONTROL

MAIN VOLUME ADJUSTMENT (FRONT SPEAKERS)

## 12-4 ADJUSTING THE PRICE OF PLAY (VTS)

This product comes equipped with a Money Controls SR3 Coin Acceptor. To adjust the price of play ALL credit setting are adjusted via the EXCEL CREDIT BOARD.

### IMPORTANT!

The CREDIT SETTINGS within the SYSTEM TEST MODE must be set to 1 coin 1 credit to allow the CREDIT BOARD to function correctly.

The VTS BD has a built in Credit Board. This is controlled by 2 DIL Switches. These allow the operator to select the price of play, type of coin acceptor and region.

### VTS Board

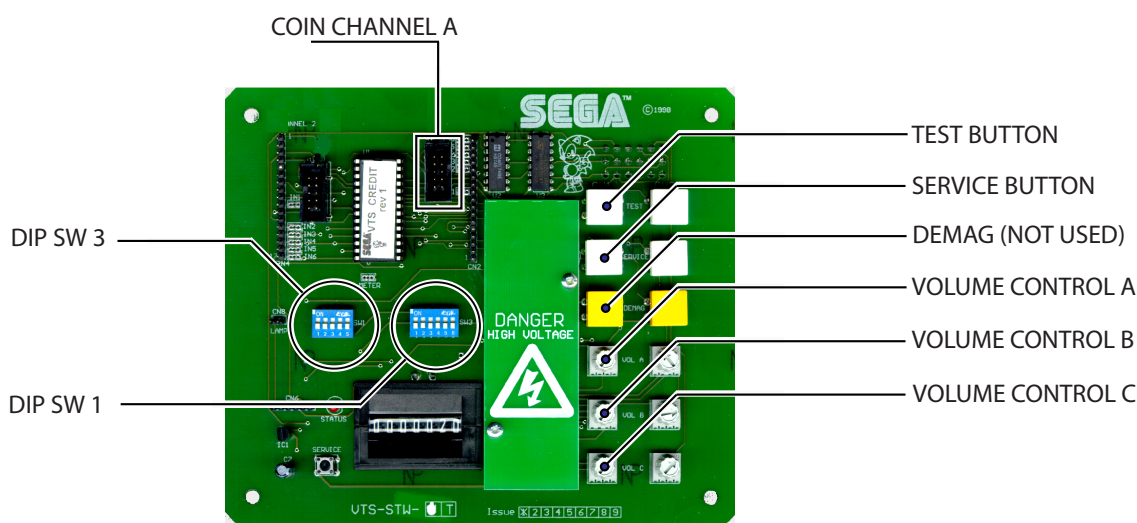

### DIL SW3 (Regional Settings)

Adjust these switches to specify the type of Coin Acceptor used and currency.

Default = SW1&SW2 ON - SR3 in parallel mode, Sterling.

TEST BUTTON	Provides access to the TEST MENU when pressed.
SERVICE BUTTON	Provides a SERVICE CREDIT when pressed
Status LED	Flashes when functioning.
CHANNEL A	To Coin Acceptor (SR3 TYPE.)
DIL SW1 (credit settings)	Adjust to required price of pay.
DEMAG	NOT USED
VOL CONTROL A	MAIN VOLUME ADJUSTMENT (FRONT SPEAKERS)
VOL CONTROL B	SECONDARY VOL ADJUSTMENT (GUN SPEAKERS)
VOL CONTROL C	NOT USED



Price	Bonus					DIL Switch 1				
	1	2	3	4	5	1	2	3	4	5
10p	50p = 5 plays	£1 = 10 plays	£2 = 20 plays			OFF	OFF	OFF	OFF	OFF
20p	50p = 6 plays @ 8.33p per play	£1 = 12 plays @ 8.33p per play	£2 = 24 plays @ 8.33p per play			ON	OFF	OFF	OFF	OFF
20p	50p = 2.5 plays	£1 = 5 plays	£2 = 10 plays			OFF	ON	OFF	OFF	OFF
20p	50p = 3 plays @ 16.66p per play	£1 = 6 plays @ 16.66p per play	£2 = 12 plays @ 16.66p per play			ON	ON	OFF	OFF	OFF
30p	50p = 1.66 plays	£1 = 3.33 plays	£2 = 6.66 plays			OFF	OFF	ON	OFF	OFF
30p	50p = 1.66 plays	£1 = 4 plays @ 25p per play	£2 = 8 plays @ 25p per play			ON	OFF	ON	OFF	OFF
30p	50p = 2 plays @ 25p per play	£1 = 4 plays @ 25p per play	£2 = 8 plays @ 25p per play			OFF	ON	ON	OFF	OFF
30p	50p = 2 plays @ 25p per play	£1 = 3 plays @ 33.33p per play	£2 = 6 plays @ 33.33p per play			ON	ON	ON	OFF	OFF
40p	50p = 1.25 plays	£1 = 2.5 plays	£2 = 5 plays			OFF	OFF	OFF	ON	OFF
40p	50p = 1.25 plays	£1 = 3 plays @ 33.3p per play	£2 = 6 plays @ 33.3p per play			ON	OFF	OFF	ON	OFF
50p	50p = 1 play	£1 = 2 plays	£2 = 4 plays			OFF	ON	OFF	ON	OFF
50p	50p = 1 play	£1 = 3 plays @ 33.3p per play	£2 = 6 plays @ 33.3p per play			ON	ON	OFF	ON	OFF
50p	50p = 1 play	£1 = 2 plays	£2 = 5 plays @ 40p per play			OFF	OFF	ON	ON	OFF
60p	50p = 0.83 play	£1 = 1.66 plays	£2 = 3.33 plays			ON	OFF	ON	ON	OFF
60p	50p = 0.83 play	£1 = 2 plays @ 50p per play	£2 = 4 plays @ 50p per play			OFF	ON	ON	ON	OFF
80p	50p = 0.62 play	£1 = 1.25 plays	£2 = 2.5 plays			ON	ON	ON	ON	OFF
80p	£1 = 1.25 plays	£1.50 = 2 plays @ 75p per play	£2 = 2.5 plays			OFF	OFF	OFF	OFF	ON
£1	2x50p = 1 play	£1 = 1 play	£2 = 2 plays			ON	OFF	OFF	OFF	ON
£1	2x50p = 1 play	£1 = 1 play	£2 = 3 plays @ 66.6p per play			OFF	ON	OFF	OFF	ON
£1	2x50p = 1 play	£2 = 2 plays	£4 = 5 plays @ 80p per play			ON	ON	OFF	OFF	ON
£1.50	3x50p = 1 play	£1 = 0.66 plays	£3 = 2 plays			OFF	OFF	ON	OFF	ON
£1.50	3x50p = 1 play	£1 = 0.66 plays	£2 = 2 plays @ £1 per play			ON	OFF	ON	OFF	ON
£2	4x50p = 1 play	£1 = 0.5 play	£2 = 1 play			OFF	ON	ON	OFF	ON
£2	4x50p = 1 play	£1 = 0.5 play	£5 = 3 plays @ £1.66 per play			ON	ON	ON	OFF	ON
£3	6x50p = 1 play	£1.50 = 0.5 play	£3 = 1 play			OFF	OFF	OFF	ON	ON
£3	6x50p = 1 play	£1.50 = 0.5 play	£5 = 2 plays @ £2.50 per play			ON	OFF	OFF	ON	ON
£5	£1 = 0.2 play	£5 = 1 play	£10 = 2 plays			OFF	ON	OFF	ON	ON
£5	£1 = 0.2 play	£5 = 1 play	£10 = 3 plays @ £3.33p per play			ON	ON	OFF	ON	ON
£7.50	£5 = 0.66 play	£10 = 1.33 plays	£15 = 2 plays			OFF	OFF	ON	ON	ON
£7.50	£5 = 0.66 play	£10 = 1.33 plays	£10 = 2 plays @ £5 per play			ON	OFF	ON	ON	ON
£10	£10 = 1 play	£20 = 2 plays	£30 = 3 plays			OFF	ON	ON	ON	ON
£10	£10 = 1 play	Free Play				ON	ON	ON	ON	ON

STERLING PRICE OF PLAY SETTINGS (SW1)

**EURO PRICE OF PLAY SETTINGS (SW1)**

	Price	Bonus					DIL Switch 1				
							1	2	3	4	5
1	10¢	50¢ = 5 plays	€1 = 10 plays	€2 = 20 plays		OFF	OFF	OFF	OFF	OFF	
2	10¢	50¢ = 6 plays @ 8.33p per play	€1 = 12 plays @ 8.33¢ per play	€2 = 24 plays @ 8.33¢ per play		ON	OFF	OFF	OFF	OFF	
3	20¢	50¢ = 2.5 plays	€1 = 5 plays	€2 = 10 plays		OFF	ON	OFF	OFF	OFF	
4	20¢	50¢ = 3 plays @ 16.66¢ per play	€1 = 6 plays @ 16.66¢ per play	€2 = 12 plays @ 16.66¢ per play		ON	ON	OFF	OFF	OFF	
5	30¢	50¢ = 1.66 plays	€1 = 3.33 plays	€2 = 6.66 plays		OFF	OFF	ON	OFF	OFF	
6	30¢	50¢ = 1.66 plays	€1 = 4 plays @ 25¢ per play	€2 = 8 plays @ 25¢ per play		ON	OFF	ON	OFF	OFF	
7	30¢	50¢ = 2 plays @ 25¢ per play	€1 = 4 plays @ 25¢ per play	€2 = 8 plays @ 25¢ per play		OFF	ON	ON	OFF	OFF	
8	30¢	50¢ = 2 plays @ 25¢ per play	€1 = 3 plays @ 33.33¢ per play	€2 = 6 plays @ 33.33¢ per play		ON	ON	ON	OFF	OFF	
9	40¢	50¢ = 1.25 plays	€1 = 2.5 plays	€2 = 5 plays		OFF	OFF	OFF	ON	OFF	
10	40¢	50¢ = 1.25 plays	€1 = 3 plays @ 33.33¢ per play	€2 = 6 plays @ 33.33¢ per play		ON	OFF	OFF	ON	OFF	
11	50¢	50¢ = 1 play	€1 = 2 plays	€2 = 4 plays		OFF	ON	OFF	ON	OFF	
12	50¢	50¢ = 1 play	€1 = 3 plays @ 33.33¢ per play	€2 = 6 plays @ 33.33¢ per play		ON	ON	OFF	ON	OFF	
13	50¢	50¢ = 1 play	€1 = 2 plays	€2 = 5 plays @ 40¢ per play		OFF	OFF	ON	ON	OFF	
14	60¢	50¢ = 0.83 play	€1 = 1.66 plays	€2 = 3.33 plays		ON	OFF	ON	ON	OFF	
15	60¢	50¢ = 0.83 play	€1 = 2 plays @ 50¢ per play	€2 = 4 plays @ 50¢ per play		OFF	ON	ON	ON	OFF	
16	80¢	50¢ = 0.62 play	€1 = 1.25 plays	€2 = 2.5 plays		ON	ON	ON	ON	OFF	
17	80¢	€1 = 1.25 plays	€1.50 = 2 plays @ 75¢ per play	€2 = 2.5 plays		OFF	OFF	OFF	OFF	ON	
18	€1	2x50¢ = 1 play	€1 = 1 play	€2 = 2 plays		ON	OFF	OFF	OFF	ON	
19	€1	2x50¢ = 1 play	€1 = 1 play	€2 = 3 plays @ 66.6¢ per play		OFF	ON	OFF	OFF	ON	
20	€1	2x50¢ = 1 play	€2 = 2 plays	€4 = 5 plays @ 80¢ per play		ON	ON	OFF	OFF	ON	
21	€1.50	3x50¢ = 1 play	€1 = 0.66 plays	€3 = 2 plays		OFF	OFF	ON	OFF	ON	
22	€1.50	3x 50¢ = 1 play	€1 = 0.66 plays	€2 = 2 plays @ €1 per play		ON	OFF	ON	OFF	ON	
23	€2	4x 50¢ = 1 play	€1 = 0.5 play	€2 = 1 play		OFF	ON	ON	OFF	ON	
24	€2	4x 50¢ = 1 play	€1 = 0.5 play	€5 = 3 plays @ €1.66 per play		ON	ON	ON	OFF	ON	
25	€3	6x50¢ = 1 play	€1.50 = 0.5 play	€3 = 1 play		OFF	OFF	OFF	ON	ON	
26	€3	6x50¢ = 1 play	€1.50 = 0.5 play	€5 = 2 plays @ €2.50 per play		ON	OFF	OFF	ON	ON	
27	€5	€1 = 0.2 play	€5 = 1 play	€10 = 2 plays		OFF	ON	OFF	ON	ON	
28	€5	€1 = 0.2 play	€5 = 1 play	€10 = 3 plays @ 3.33¢ per play		ON	ON	OFF	ON	ON	
29	€7.50	€5 = 0.66 play	€10 = 1.33 plays	€15 = 2 plays		OFF	OFF	ON	ON	ON	
30	€7.50	€5 = 0.66 play	€10 = 1.33 plays	€10 = 2 plays @ €5 per play		ON	OFF	ON	ON	ON	
31	€10	€10 = 1 play	€20 = 2 play	€30 = 3 play		OFF	ON	ON	ON	ON	
32			Free Play			ON	ON	ON	ON	ON	

## 13 SEAT MECHANISM

### WARNING

- This work should be performed by site maintenance personnel or other skilled professionals. Work performed by non-technical personnel can cause a severe accident such as electric shock.
- When working with the product, be sure to turn the power OFF. Working with the power on may cause an electric shock or short circuit.
- Exercise due caution in performing soldering procedures. If a soldering iron is handled carelessly it could cause a burn or start a fire.
- Proceed very carefully when heating thermal contraction tubes (heatshrink). Careless heating of such tubes may cause burns or fire.
- Be careful not to damage wires. Damaging wires may cause electric shock, short circuit or present a risk of fire.
- Do not touch undesignated places. Handling or touching such places may cause an electric shock, short circuit or crush hazard.
- Stand back from the cabinet when applying power after maintenance has been completed. The seat will automatically undergo an initialization operation when power is restored. Failure to move away from the product could result in a crush, pinch or fall hazard.

### CAUTION

- Be careful not to get a hand or finger caught when removing or attaching parts within the moving mechanism.
- Exercise extreme caution when handling the internal parts on the rear cabinet. Pay special attention when examining the rear cabinet, inspect for damage, loss of components or warping. The loss of just one component i.e screw, can result in damage or lead to damage and faulty operation of the entire unit.

### IMPORTANT

After replacing or adjusting the volume, always set the volume movement values at the CABINET SETTING>SEAT MOTION TEST in TEST MODE.



## 13-1 PITCH VOLUME

### 13-1-1 PITCH VOLUME ADJUSTMENT

- 1 Turn OFF the power switch.

*Note: Turn off the power when the cabinet is in Advertise Mode and the seat is not moving.*

- 2 Using an Allen wrench, remove the 4 inner hex socket screws positioned along the top rail of the seat back. Once removed carefully lift the seat back in an upwards movement to unlatch it for the base.

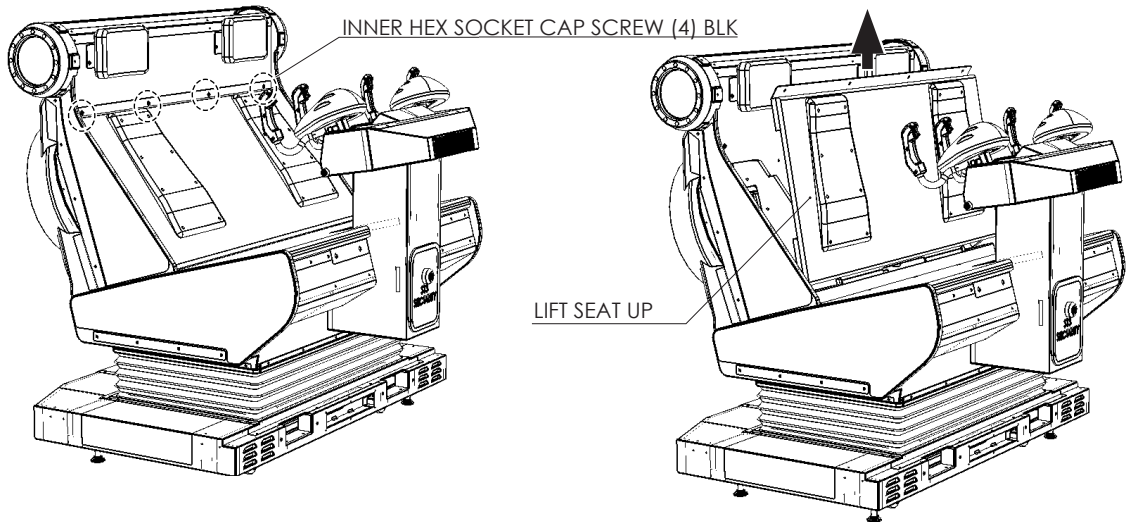

- 3 Using the Allen wrench, remove the 4 inner hex socket screws from the front of the seat base..

INNER HEX SOCKET  
CAP SCREW (4) BLK

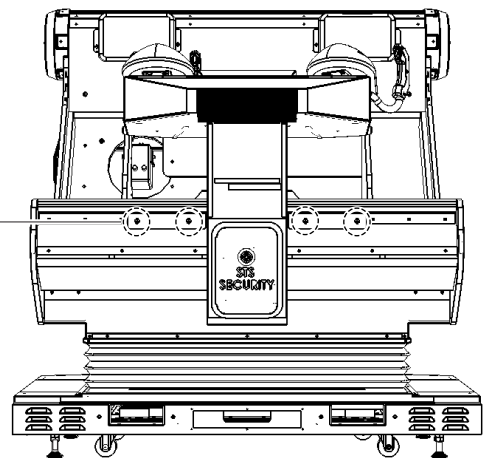

- 4 Lift the seat base from the rear and tilt upwards to remove.

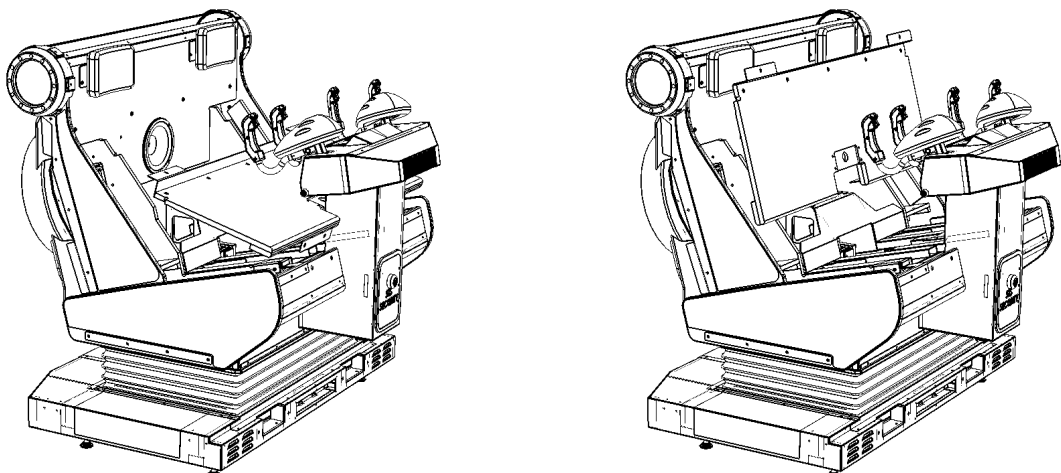



- 5** Locate the Pitch Volume Bracket and loosen the 2 screws to adjust the gear mesh angle and seating. Ensure that the D cut surface of the volume control axis is as shown in the figure when the seat is in its horizontal position.

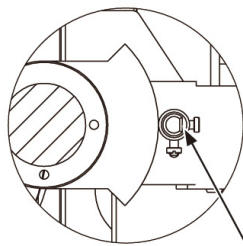
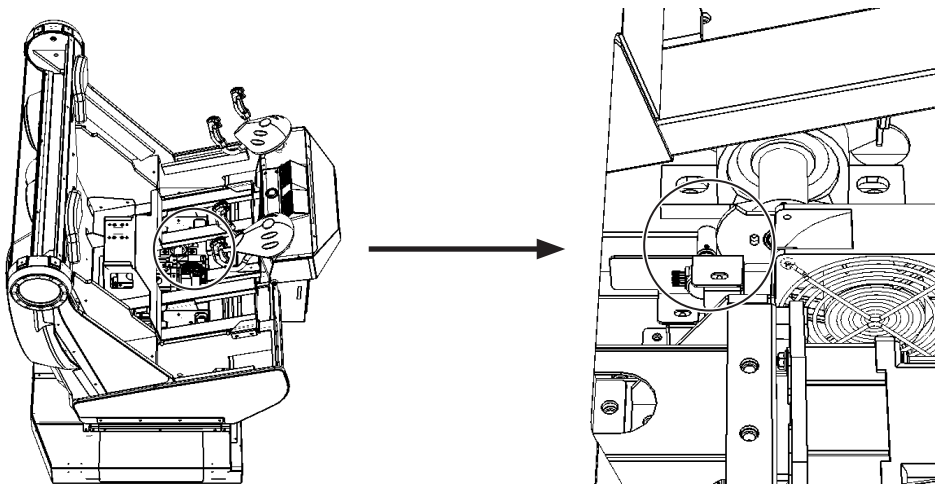

D CUT SURFACE

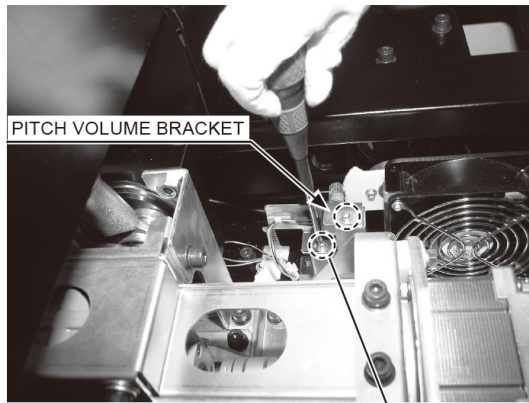

SCREW (2)

M4 x 8, w/flat &amp; spring washers

- 6** After adjusting, tighten the 2 screws and refer to the previous steps in reverse order to reassemble the seat back and base.
- 7** Turn on the power. Take care and stand back from the seat when initializing.
- 8** Go to CABINET SETTINGS > SEAT MOTION TEST in the GAME TEST MODE and check the setting value. The recommended pitch volume setting when the seat is in its horizontal position is  $80H \pm 10H$ . Check to make sure that the value decreases when the front of the seat moves in a downward motion and increases when the seat moves in an upward movement..

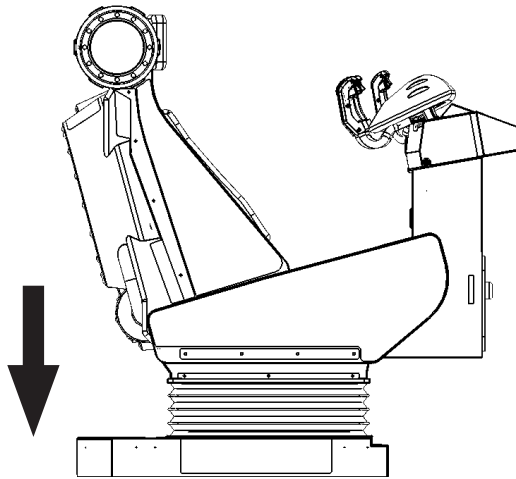

VALUE DECREASES

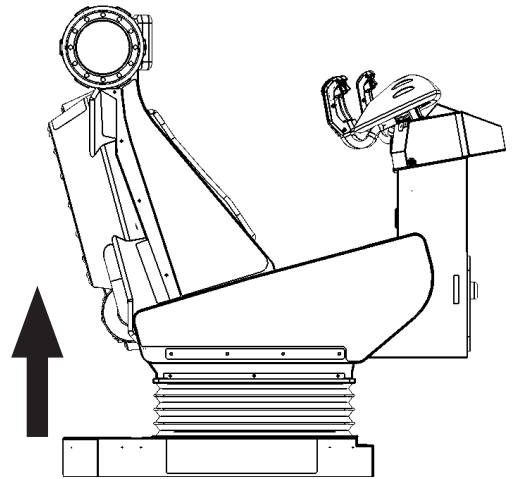

VALUE INCREASES

### 13-1-2 PITCH VOLUME REPLACEMENT

- 1 Turn off the power when the seat is in Advertise Mode and the seat in NOT moving.
- 2 Refer to Steps 2 to 4 in the previous section to remove the Seat back and base.
- 3 Undo the cord clamp and disconnect the connector. Be careful not to damage the wires when doing so.

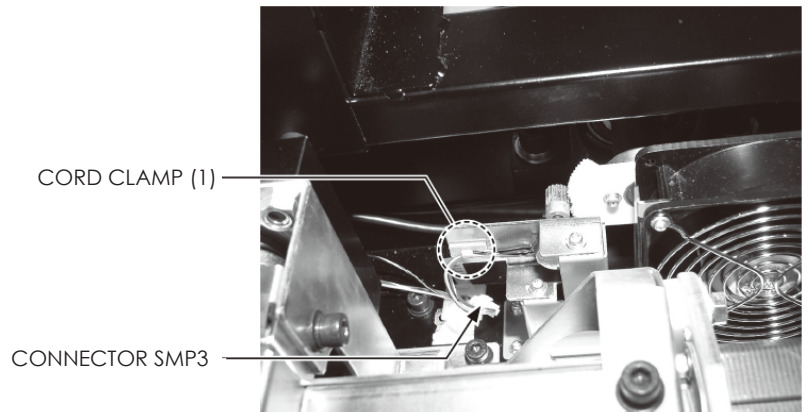

- 4 Remove the 2 screws and take off the pitch volume.

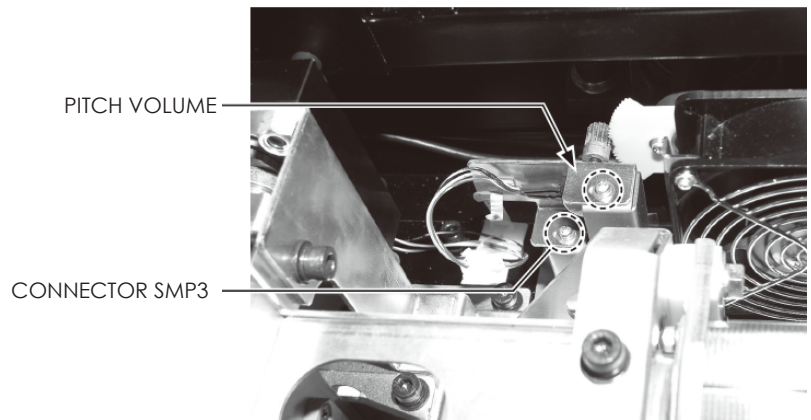

- 
- 5** Remove the setscrews and remove the gear from the volume shaft.

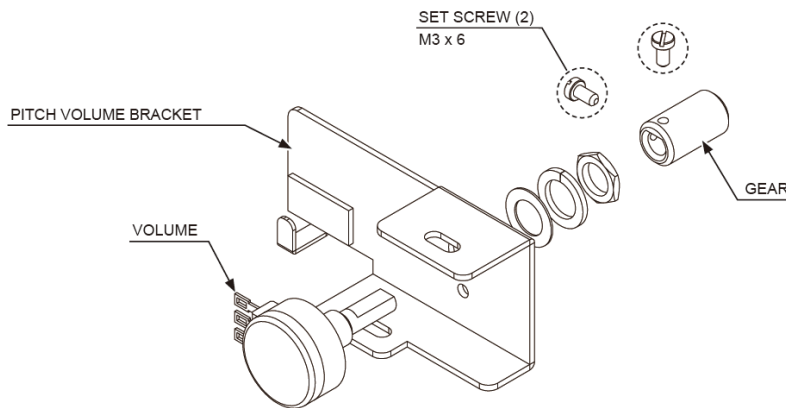

- 
- 6** Remove the nut holding the pitch volume bracket in place and take the volume off the pitch volume bracket.

- 
- 7** The wires connect to the volume will be reused. Use a tool such as a pair of snips or cutters to remove the old heatshrink tubes from the areas were the wires are connected.

- 
- 8** Use a soldering iron to separate the wires from the old volume pot. Be careful when using a soldering iron as in may burn.

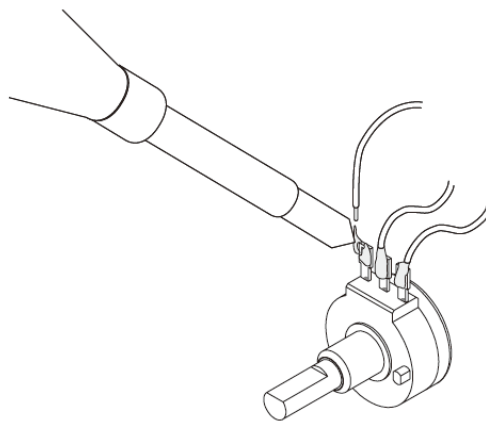

- 
- 9** If the exposed conductive wire at the end is less than 5mm, use a pair of wire strippers to cut back the insulation.

- 
- 10** Pass the wires through the heatshrink tubes and resolder the wires into the same position on the newly replaced volume pot. If needed, check the wiring diagram for wire positions.

- 
- 11** Cover the contacts with the heatshrink tubes and apply heat using the appropriate heat gun to tightly cover the soldered parts.

- 
- 12** Refer to steps 2 to 6 and work in reverse order to re-attach the pitch volume pot, seat and seat back.

- 
- 13** Refer to steps section 13-1-1 for adjustment for the pitch volume.

**STOP** IMPORTANT

- Be sure to use the designated grease. Using an undesignated grease can cause parts damage.
- Do not apply grease to locations other than those specified. Doing so may create a risk of operational problems and deterioration of parts.
- The designated periods for greasing serve only as a guide. Whenever there are squeaks or other anomalies, apply grease at designated locations.

Grease the parts listed below once every three months.  
Use GREASE MATE (PART No. 090-0066) spray grease.

**1** Refer to steps 1 to 4 of 13-1-1 PITCH VOLUME ADJUSTMENT and remove the seat and seat back.

**2** Grease the gear interface as shown in the figure.

APPLY GREASE

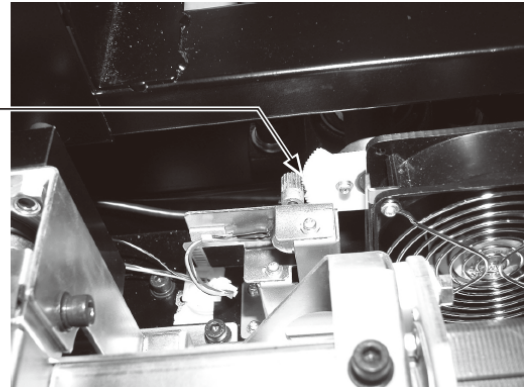

## 13-2 ROLL VOLUME

### 13-2-1 ROLL VOLUME ADJUSTMENT

- 1 Turn OFF the power switch.  
*Note: Turn off the power when the cabinet is in Advertise Mode and the seat is not moving.*

- 2 Remove the 4 screws and take off the bellows upper base hatch.

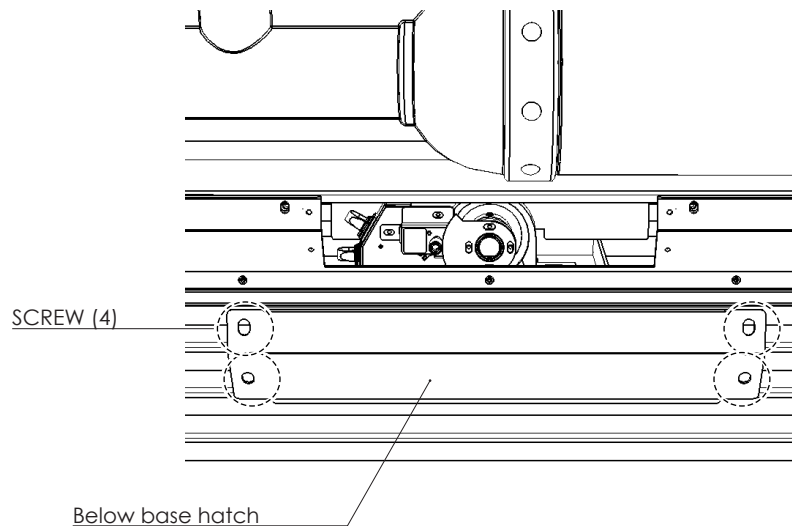

- 3 Loosen the 2 screws and move the volume bracket to adjust the gear mesh angle and seating position. Ensure the D cut surface of the volume control axis is as shown in the figure when the seat is in its horizontal position.

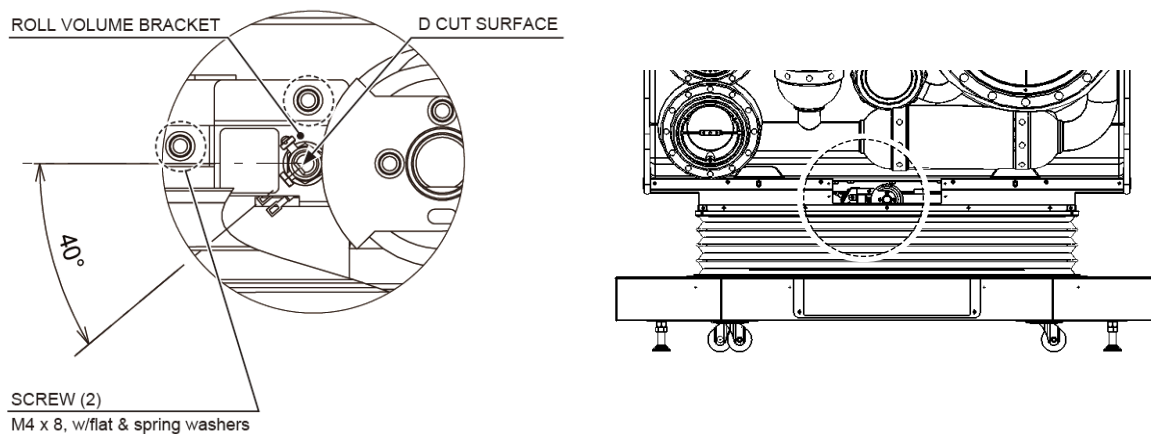

- 4 After adjusting, tighten the 2 screws and refer to step 2 to reattach the upper bellow base hatch..

- 5 Turn on the power and stand back from the seat. The seat will initialize automatically once the power has been re-established.

- 6 Go to CABINET SETTING > SEAT MOTION TEST in GAME TEST MODE and check the setting value. The recommended roll volume setting when the seat is horizontally orientated is  $80H \pm 10H$ . Check to make sure the value decreases when the 1P side of the seat moves down and increases when the 2P side of the seat moves down.

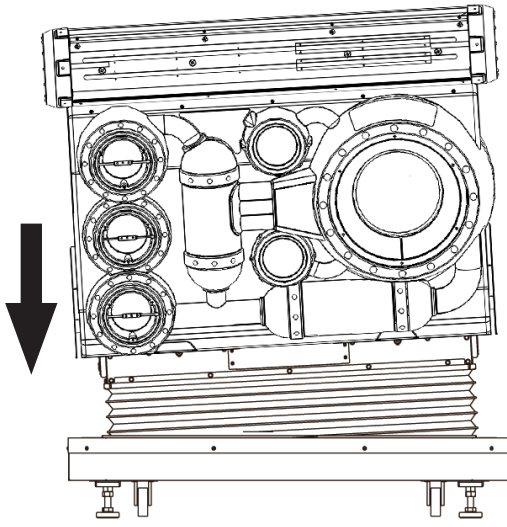

Value Decreases

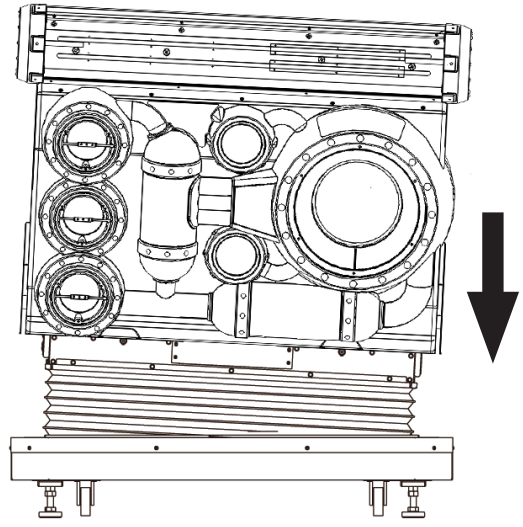

Value Increases

## 13-2-2 ROLL VOLUME REPLACEMENT

- 1 Turn OFF the power switch.  
*Note: Turn off the power when the cabinet is in Advertise Mode and the seat is not moving.*

- 2 Refer to step 2 of 13-2-1 ROLL VOLUME ADJUSTMENT and remove the upper bellow base hatch.

- 3 Undo the cord clamp and disconnect the connector. Be careful not to damage wires when doing so.

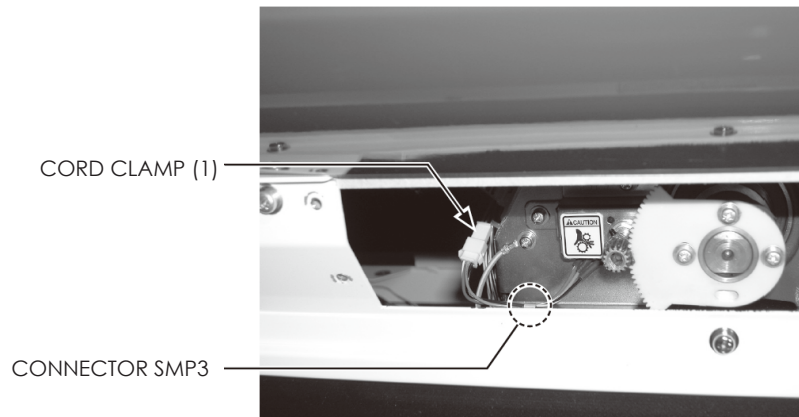

- 4 Remove the 2 screws and take off the roll volume pot.

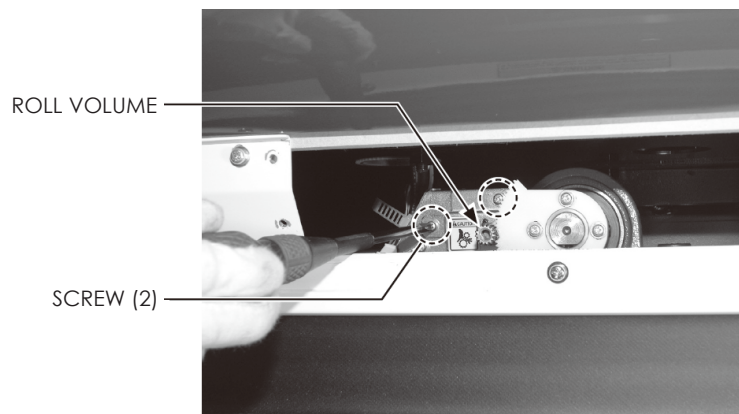

- 5 Remove the 2 screw sets and pull the gear off the volume shaft.

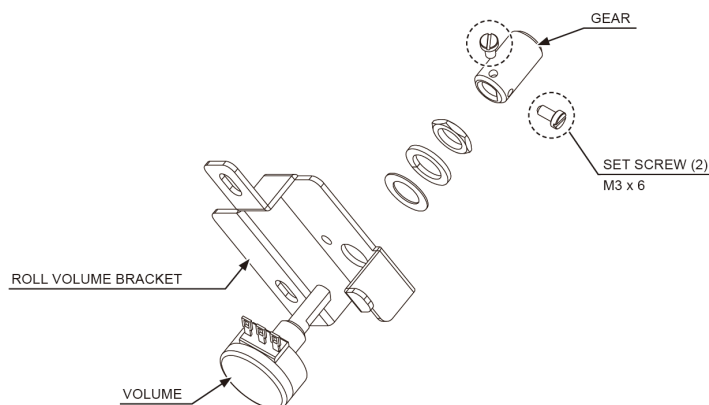

- 6 Remove the nut holding the roll volume bracket in place and take the volume off the roll volume bracket.
- 7 The wires connect to the volume will be reused. Use a tool such as a pair of snips or cutters to remove the old heatshrink tubes from the areas were the wires are connected.
- 8 Use a soldering iron to separate the wires from the old volume pot. Be careful when using a soldering iron as in may burn.

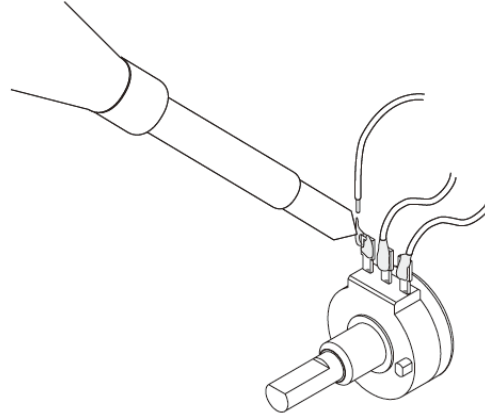

- 9 If the exposed conductive wire at the end is less than 5mm, use a pair of wire strippers to cut back the insulation.
- 10 Pass the wires through the heatshrink tubes and resolder the wires into the same position on the newly replaced volume pot. If needed, check the wiring diagram for wire positions.
- 11 Cover the contacts with the heatshrink tubes and apply heat using the appropriate heat gun to tightly cover the soldered parts.
- 12 Refer to steps 2 to 6 and work in reverse order to re-attach the roll volume pot, seat and seat back.
- 13 Refer to steps section 13-1-1 for adjustment for the roll volume.



**STOP** IMPORTANT

- Be sure to use the designated grease. Using an undesignated grease can cause parts damage.
- Do not apply grease to locations other than those specified. Doing so may create a risk of operational problems and deterioration of parts.
- The designated periods for greasing serve only as a guide. Whenever there are squeaks or other anomalies, apply grease at designated locations.

Grease the parts listed below once every three months.  
Use GREASE MATE (PART No. 090-0066) spray grease.

**1** Refer to steps 1 to 4 of 13-2-1 ROLL VOLUME ADJUSTMENT and remove the upper bellows hatch.

**2** Grease the gear interface as shown in the figure.

APPLY GREASE.

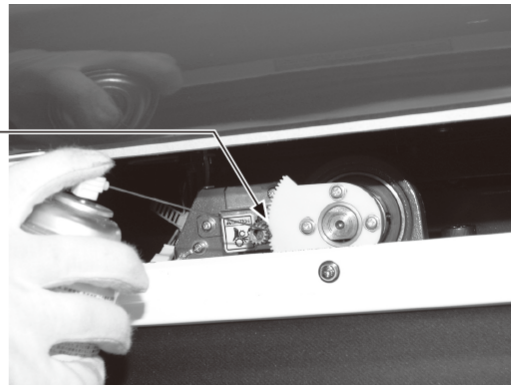

## 14 PERIODIC INSPECTION

The items listed below require periodic check and maintenance to retain the performance of this machine and to ensure safe business operation.

When handling the controller, the player will be in direct contact with it. In order to always allow the player to enjoy the game, be sure to clean it regularly. Also, it is advisable to provide wet tissue, etc. available for player use.

### WARNING

- Every 6 months check to see if power cords are damaged, the plug is securely inserted, dust is accumulated between the socket outlet and the power plug, etc. Dust will accumulated if using the product regularly. Continued use with the presence of accumulated dust may result in a fire and or electric shock.
- There is the danger of accidents involving electrical shorts circuits or fire caused by factors such as the deterioration of insulation in electrical and electronic equipment over time. Check that there are no abnormalities such as odors from burning.
- For all normal maintenance procedures, always turn off the power before beginning. Starting the procedures with the power still on can result in electric shocks or short circuits.
- When restoring power after maintenance is completed or going into or coming out of the Test Mode, be sure to verify that there are no people near the product. When the power is restored or when coming out of Test Mode, the product will automatically undergo initialization operation. If people are near the product, it could result in an accident involving the moving mechanism.
- In the event that parts related to the ride mechanisms (motors or reducers, etc.) are damaged or break down, or when parts replacement or repairs are needed, request work be done by the point of purchase or the office listed in this manual. Such procedures require specialized knowledge, techniques, and tools. Improperly performed procedures can result in accidents.
- Do not use a water jet (high pressure washing device) or hose to clean this product. It was not designed to be cleaned by a water jet. Water could get inside and cause electrocution or short circuits. The product could also be damaged in such a way that it is difficult to repair.

### CAUTION

- Be careful not to get your fingers caught when opening/closing or attaching/removing doors, lids and other such parts.
- When working inside the cabinet, you could get caught on parts or scratch yourself on them. Check the inside of the cabinet and be aware of where the parts are before performing the work.

## Cleaning the Cabinet Surfaces

When the cabinet surfaces are badly soiled, remove stains with a soft cloth dipped in water or diluted with a chemical detergent and squeezed dry. To avoid damaging surface finish, do not use such solvents as thinner, benzine, etc. other than ethyl alcohol, or abrasives, bleaching agent and chemical dustcloth.

Some general-purpose household, kitchen and furniture cleaning products may contain strong solvents that degrade plastic components, coatings, and print. Before using any cleaning product, read the product's cautionary notes carefully and test the product first on a small area that is not highly visible.

## DISPLAY (LCD SCREEN Cleaning)

When the Display LCD Screen surfaces are dirty, smudges or greasy, gently wipe the display with a dry, lint-free, soft cloth. If you see a scratch-like mark on your display, it might be a stain which has been transferred from food like matter when the screen was depressed from the outside. To avoid damaging surface finish, do not use such solvents as thinner, benzine, etc. the same applies to ethyl alcohol, or abrasives, bleaching agent and chemical dustcloths.

Wipe or dust the stain gently with a dry, soft cloth. If the stain remains, moisten a lint-free, soft cloth with water or a 50-50 mixture of isopropyl alcohol and water that does not contain impurities. Wring out as much of the liquid as possible and wipe the display again; do not let any liquid drip from the cloth.

Antistatic and purpose made LCD cleaning wipes are also acceptable alternatives.

## **STOP** IMPORTANT

**Isopropyl Alcohol is a flammable liquid.**

**Do not use this cleaner near an exposed flame or clean the screen when it is powered on..**

**PERIODIC INSPECTION TABLE**

PERIOD	ITEMS	DESCRIPTION
As appropriate	CABINET SURFACE	Cleaning
	LAMPS	Inspection
Daily	CABINET	Confirm adjusters contact floor
	SAFETY DEVICES	Confirm bellows
		Check rubber on foot guard
Weekly	LCD	Screen Cleaning
		Check monitor adjustment
Monthly	START, MOTION STOP	Check switches and lamps
	CONTROLLER	Inspect volume pots
	REAR CABINET	Inspect volume pots
	COIN SELECTOR	Coin switch inspection
		Coin insertion test
RINGWIDE	Settings check	
Every 3 Months	CONTROLLER	Inspect gear meshing
		Apply grease
	REAR CABINET	Inspect gear meshing
		Apply grease
COIN SELECTOR	Cleaning	
1 year	RINGWIDE	Cleaning
	POWER PLUG	Inspection, Cleaning
	FRONT CABI INTERIOR	Cleaning

# 15 TROUBLESHOOTING

## 11-1 TROUBLESHOOTING (WHEN NO ERROR MESSAGE IS SHOWN)

### WARNING

- In order to prevent electric shock and short circuit, be sure to turn power off before performing work.
- Be careful so as not to damage wirings. Damaged wiring can cause electric shock or short circuit.
- After removing the cause of the functioning of the Circuit Protector, reinstate the Circuit Protector. Depending on the cause of the functioning, using the Circuit Protector as is without removing the cause can cause generation of heat and fire hazard.
- In the event that a problem cannot be resolved by employing the procedures listed in this Manual, be sure to request service from the office shown on this Manual or the dealer from whom the product was originally purchased. Attempts to employ procedures other than those specified in this Manual can cause electrical shock, shorting, or fire.
- In the event of a problem that is not described here, be sure to contact the office shown on this Manual or the dealer from whom the product was originally purchased. Careless attempts at repair can result in electrical shock, shorting, or fire.

### Replacing Fuses

### WARNING

- In case fuse replacements other than those stated in this manual are necessary, contact where you purchased the product from for inquiries regarding this matter.
- In order to prevent an electric shock, be sure to turn power off and unplug from the socket outlet before performing work by touching the internal parts of the product.
- Be careful so as not to damage wirings. Damaged wiring can cause electric shock and short circuit accidents.
- Be sure to use fuses meeting specified rating. Using fuses exceeding the specified rating can cause fire and electric shock accidents.
- After eliminating the cause of the blowing of fuse, replace the fuse. Depending on the cause of fuse blowing, continued use with the fuse as is blown can cause generation of heat and fire hazard.

 **WARNING**

- This work should be performed by site maintenance personnel or other skilled professionals. Work performed by non-technical personnel can cause a severe accident such as an electric shock. If there are no site maintenance personnel or other skilled professionals available, turn the power off immediately and contact the office given in this manual or from the point of purchase.
- When working with the product, be sure to turn the power off. Working with the power on may cause an electric shock or short circuit. When working with the product, be sure to turn the power off. Working with the power on may cause an electric shock or short circuit.
- Be careful not to damage the wires. Damaged wires may cause electric shock or short circuit or present a fire risk.
- After the cause of circuit protector activation has been removed, have the circuit protector re-engaged. If the unit is used continuously as is, there could be heat generation or fire, depending on the cause of the activation.
- When the power has been engaged or the TEST MODE has been terminated, initialization takes place automatically. If anyone is near the product, they could come in contact or collide with it. Check carefully to be sure that no one is near the product and that no tools or items have been left on the product, then engage the power or terminate TEST MODE.
- If problems other than those covered in this manual arise, or if no improvements can be noted after measures given in this manual have been taken, do not take measures indiscriminately. Cut off the power immediately and contact the office shown in this manual or the dealer from whom the product was originally purchased. Indiscriminate countermeasures could lead to unforeseeable accidents. They could also result in permanent damages. Also, if the power is left on while there is an abnormality, a fire, electric shock or other serious accident can occur.

 **IMPORTANT**

- If an error message is displayed, identify the cause right away and take the appropriate countermeasures. Leaving the error unaddressed could result in a breakdown.
- If a problem occurs, first inspect the connection of any wiring connectors.
- Static electricity from your body may damage some electronics devices on the IC board. Before handling the IC board, touch a grounded metallic surface so that the static electricity can be discharged.

PROBLEM	CAUSE	COUNTERMEASURE
With main switch ON there is no activation	Power is not supplied	Insert power lead all the way into outlet
	Supply voltage is not correct	Make sure that supply voltage is correct
	Circuit protector activated	Reset circuit protector/replace fuse
There is sound and lighting but no video signal	Video signal connector or monitor power connector is not properly connected	Check connections of the monitor and RINGWIDE connector
No sound	Volume not properly adjusted	Adjust volume
	Poor connection of connectors	Check connections of RINGWIDE and amp
	Board, amp or speaker fault	Run speaker test to check.
Incorrect colour on monitor	Poor connection of video cable	Confirm connection of video/VGA cable.
	Monitor fault	Contact point of purchase
Screen saturation and brightness not correct	Screen not properly adjusted	Adjust screen settings
Switch and volume pot input does not work	Poor connection of connectors	Check connection to I/O bd
		Check the connection to RINGWIDE
Start button input does not work	Switch fault	Replace switch
Start button does not light	Lamp failure	Replace lamp
Stays on RINGWIDE logo and does not go to advertise screen (error)	Poor condition of cabinet	Refer to list of errors
	RINGWIDE error	Contact point of purchase
Controller does not work properly	Improper controller settings	Configure settings in TEST mode
	Poor attachment of volume pots or misalignment of gears	Adjust volume pot and set in calibration settings
	Poor connection of connectors	Check volume pot connections
	Volume pot failure	Replace volume pot
Seat does not work correctly	Faulty initialization	Turn the power on/off and make sure the initialization operation completes successfully
	Poor attachment of volume pots or misaligned gears	Adjust the volume pots and check in TEST mode
	Volume pot failure	Replace the volume pot
Seat does not move	Faulty initialization	Turn the power on/off and make sure the initialization operation completes successfully
	Improper settings	Check the DIP SW
	Poor connections	Check RINGWIDE connections and joint connections
	Thermal element on servo motor engaged	It engages when the temperature inside the motor gets too hot - it will recover when cool.

## 16 GAME BOARD (RINGWIDE)

16

GAME BOARD

### WARNING

- When working with the product, be sure to turn the power off. Working with the power on may cause an electric shock or short circuit.
- Be careful not to damage the wires. Damaged wires may cause an electric shock, short circuit or present a risk of fire.
- Do not use this product with connectors other than those that were connected and used with the game board at the time of shipping. Do not carelessly connect wires to connectors that were not used at the time of shipping, as this may cause overheating, smoke or fire damage.

### CAUTION

In this product, setting changes are made during the test mode. The game board need not be operated. Use the game board, etc. as is with the same setting made at the time of shipment so as not to cause electric shock and malfunctioning.

### STOP IMPORTANT

Static electricity from your body may damage some electronics devices on the IC board. Before handling the IC board, touch a grounded metallic surface so that the static electricity can be discharged.



## 16-1 HANDLING PRECAUTIONS

### WARNING

- To prevent electric shock or IC Board malfunctioning, be sure to turn off the power for the cabinet when installing or removing the IC Board.
- Extraneous matter such as dust on the IC Board can cause the IC Board to generate heat and result in a fire due to short circuit, etc. Ensure the IC Board surfaces are always kept clean.
- Keep the IC board well cooled. RINGWIDE is provided with ventilating fans. Do not block the air outlets of these fans. Also do not place anything closely to RINGWIDE. Failure to observe these instructions may cause an overheating and fire.
- Always follow the usage conditions from SEGA as well as the usage conditions for the cabinet you are using for RINGWIDE. Failure to do so may cause an overheating and fire.

### IMPORTANT

- Be sure to connect the IC Board and connectors completely. Insufficient insertion can damage IC Board, etc.
- For the IC Board circuit inspection, only the use of Logic Tester is permitted. The use of ordinary testers is not permitted as these can damage the IC Board.
- Do not subject the IC Board to static electricity when installing the IC Board in the cabinet or when connecting wire harness connectors to the IC Board.
- When soldering buttons, etc. to the wire harnesses, be sure to remove the wire harnesses from the IC Board so as not to subject the IC Board to heat.
- Using RINGWIDE without the Shield Case can cause electric wave trouble. Be sure to use RINGWIDE together with the accessory Shield Case.
- Some parts are the ones designed and manufactured not specifically for this product. The manufacturers may discontinue, or change the specifications of, such general-purpose parts. If this is the case, SEGA cannot repair or replace a failed product whether or not a warranty period has expired.

## 16-2 PARTS DETAILS

16

GAME BOARD

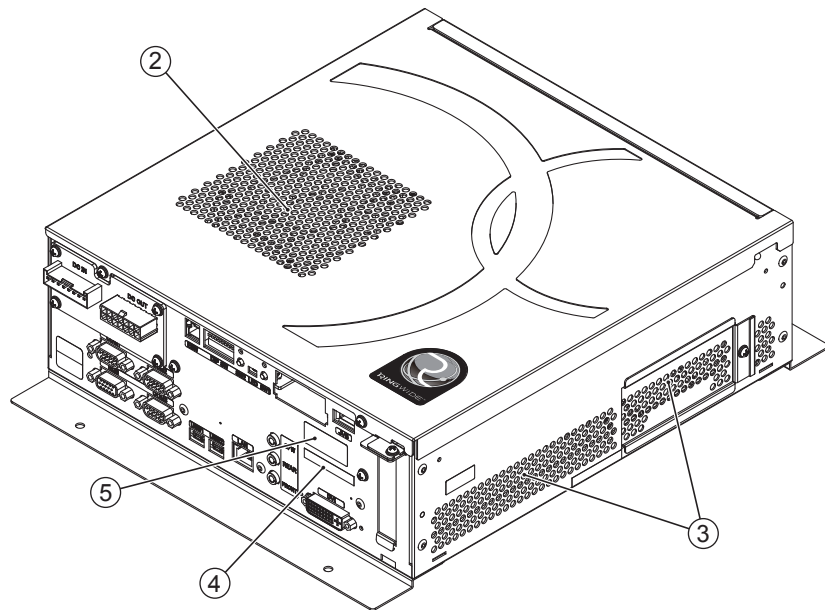
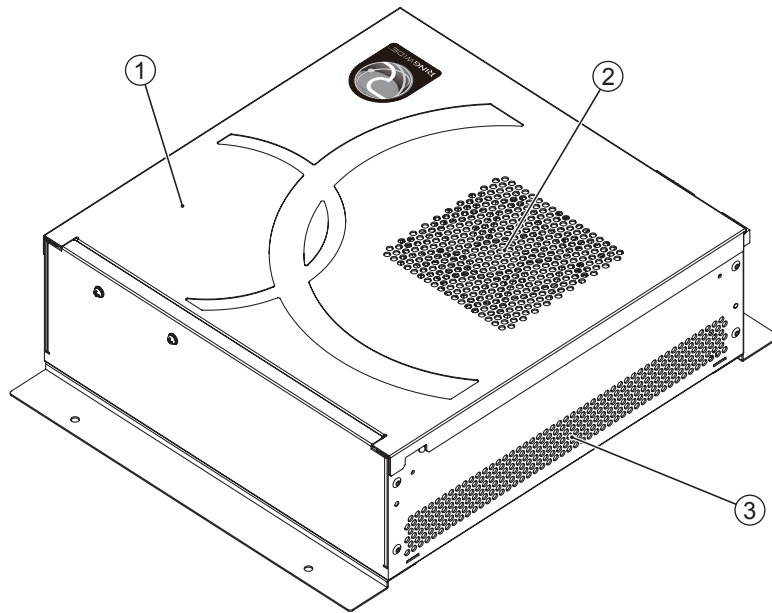

- ① Shield case
- ② Exhaust vent (Do not block or cover.)
- ③ Intake vent (Do not block or cover.)
- ④ Board number
- ⑤ Board serial number

## CONNECTORS, SWITCHES AND LED

### ⚠ WARNING

- When connecting the connector, check the orientation and type carefully and connect securely. The connector must be connected in the proper direction and type. If it is connected in the wrong direction or indiscriminately at an incline, or connected wrong connector, so that a load is applied, the connector or its terminal pins could break, causing a short circuit or fire.
- Do not connect components to ⑨ JVS I/O that are not designated by SEGA. Connecting unspecified components could cause an accident such as an electric shock or fire.

16

GAME BOARD

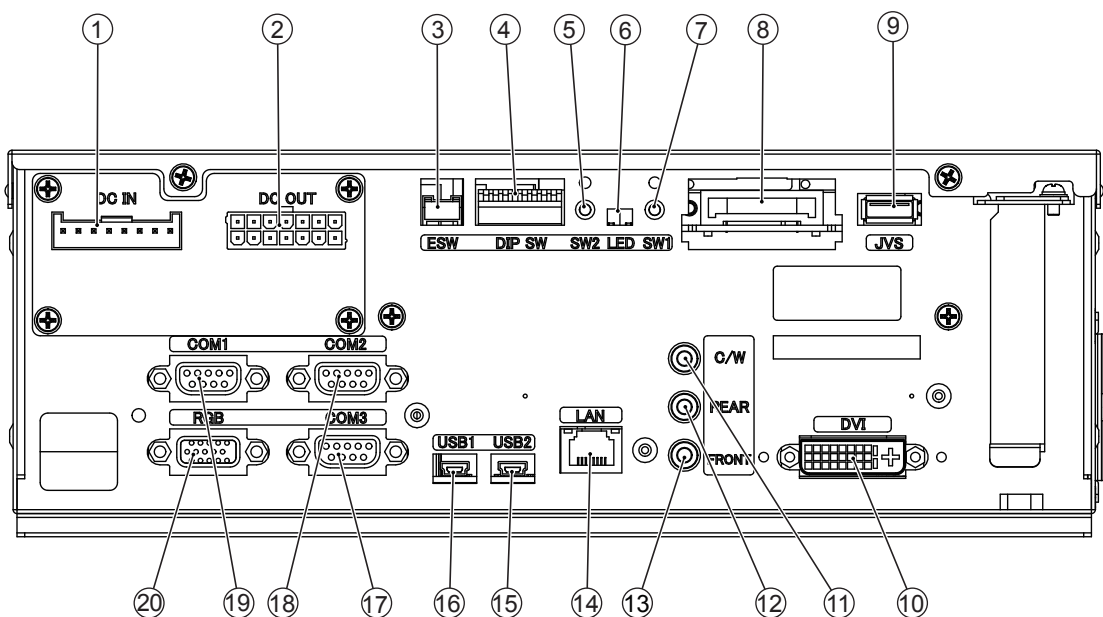

- ① Power input port
- ② External power supply port
- ③ Test/Service button external input port
- ④ DIP SW (Dip switches)
- ⑤ Service button (SW2)
- ⑥ LED1, LED2 (From right to left: 1, 2)
- ⑦ Test button (SW1)
- ⑧ Key chip socket
- ⑨ JVS I/O port
- ⑩ DVI output
- ⑪ Center/Woofer lineout
- ⑫ Rear lineout
- ⑬ Front lineout
- ⑭ LAN port
- ⑮ USB port 2
- ⑯ USB port 1
- ⑰ Serial communication port 3
- ⑱ Serial communication port 2
- ⑲ Serial communication port 1
- ⑳ RGB output

① Power Input Port

Terminal No.	Signal Name	Terminal No.	Signal Name
1	GND	5	+12V DC IN
2	GND	6	+12V DC IN
3	GND	7	+12V DC IN
4	GND	8	+12V DC IN

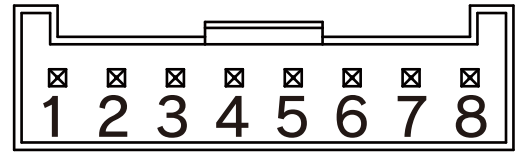

NOTE: Before connecting, be sure to check the type of connector.

② External Power Supply Port

Terminal No.	Signal Name	Terminal No.	Signal Name	Maximum Output Current
1	GND	8	+12V DC	2.3A
2	GND	9	+12V DC	
3	GND	10	+12V DC	
4	GND	11	+5V DC	2.3A
5	GND	12	+5V DC	
6	GND	13	+5V DC	
7	N.C.	14	N.C.	-

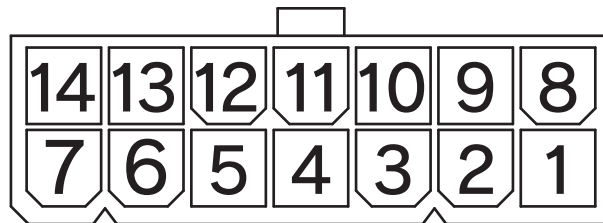

NOTE: Before connecting, be sure to check the type of connector.

③ Test/Service Button External Input Port

Terminal No.	Signal Name
1	SW1
2	SW2
3	GND

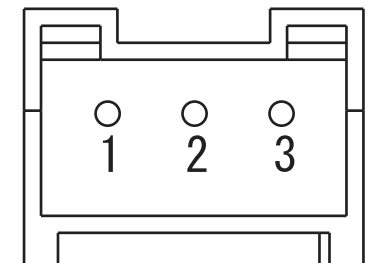

#### ④ DIP SW

No. 1, No. 2 and No.3:

Use differs depending on game software. Set according to the Service Manual provided with the game software itself.

No. 4:

Changes the facing of the monitor. Use differs depending on game software. Set according to the Service Manual provided with the game software itself. If no specific directions are given set to horizontal display (OFF).

OFF: Horizontal display

ON: Vertical display

No. 5, No. 6 and No. 7:

Set the resolution of the video output.

Use differs depending on game software. Set according to the Service Manual provided with the game software itself.

Resolution	No. 5	No. 6	No. 7
*	OFF	OFF	OFF
640 x 480	ON	OFF	OFF
1024 x 600	OFF	ON	OFF
1024 x 768	ON	ON	OFF
1280 x 720	OFF	OFF	ON
<b>1280 x 1024</b>	<b>ON</b>	<b>OFF</b>	<b>ON</b>
1360 x 768	OFF	ON	ON
1920 x 1080	ON	ON	ON

**For DREAM RAIDERS the resolution is 1280x720**

No. 8:

Use differs depending on game software. Set according to the Service Manual provided with the game software itself.

The switch settings for DREAM RAIDERS

The diagram below shows all 8 switches in the OFF position.

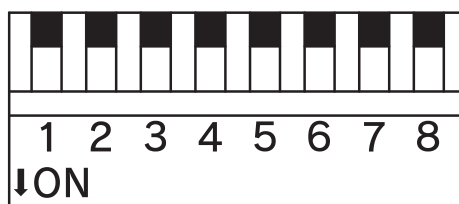

No. 1	No. 2	No. 3	No. 4	No. 5	No. 6	No. 7	No. 8
OFF	OFF	OFF	OFF	OFF	OFF	OFF	OFF

## 16-3 RINGWIDE COMPONENTS

### ■ ACCESSORIES

Parts not labeled with part numbers are as yet unregistered or cannot be registered. Be sure to handle all parts with care, as some parts are not available for purchase separately.

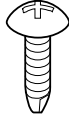
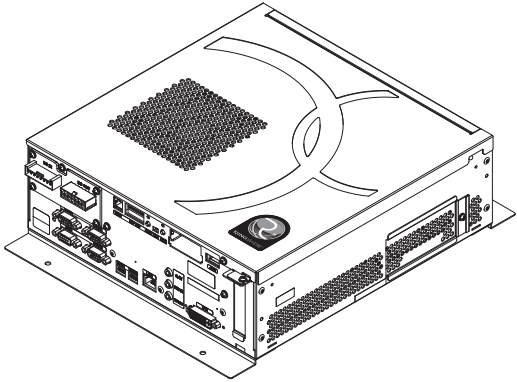
DESCRIPTION/PART NO.	FIGURES/NOTES	QTY
TAPPING SCREW 011-P00412	 Used for installing the RINGWIDE.	4
RINGWIDE  847-0001D-01 : USA 847-0001D-02 : OTHERS		1 ea.

## 16-4 ERROR CODE DISPLAY

### WARNING

- If an error code is displayed get on-site maintenance personnel or other qualified professional to look at it. An unqualified person attempting to resolve an error code problem may lead to electric shock, short circuit and risk of fire.  
If no on-site maintenance personnel or qualified professional is available immediately turn off the power and contact the customer services in this manual or your supplier.
- If a problem not described in this manual occurs, or the resolution to a problem described in this manual is not effective, do not make further attempts to resolve the problem yourself. Immediately turn off the power and contact the office listed in this manual or your supplier. Any unguided attempts to solve such problems may lead to a serious accident.

### IMPORTANT

If an error number or message not listed below appears, cease using the product immediately and contact the office listed in this manual or the point of purchase for this product.

RINGWIDE is equipped to display various errors on-screen to help solve any problems. If an error is displayed the game cannot be used. Use the following table of causes and countermeasures to solve the problem.

<b>DISPLAY</b>	Error 0001 Keychip Not Found
<b>CAUSE</b>	There is no key chip, or the key chip is not connected correctly.
<b>COUNTERMEASURES</b>	Check that the key chip is connected correctly.

<b>DISPLAY</b>	Error 0002 Keychip Not Available
<b>CAUSE</b>	The key chip is not supported. The RINGWIDE system program must be updated.
<b>COUNTERMEASURES</b>	Check how the game was installed. If that doesn't fix the problem, contact the office listed in this manual or the point of purchase for this product.

<b>DISPLAY</b>	Error 0004 Game Program Not Acceptable
<b>CAUSE</b>	The key chip is not supported.
<b>COUNTERMEASURES</b>	Check that the key chip from a different system is not inserted. If that doesn't fix the problem, contact the office listed in this manual or the point of purchase for this product.

<b>DISPLAY</b>	Error 0008 Keychip Access Failed
<b>CAUSE</b>	The key chip could not be accessed.
<b>COUNTERMEASURES</b>	Reinsert the key chip and restart RINGWIDE. If that doesn't fix the problem, contact the office listed in this manual or the point of purchase for this product.

<b>DISPLAY</b>	Error 0010 Unexpected Game Program Failure
<b>CAUSE</b>	The game program crashed due to an unexpected error.
<b>COUNTERMEASURES</b>	Turn the power off and then restart the RINGWIDE. If that doesn't fix the problem, contact the office listed in this manual or the point of purchase for this product.

<b>DISPLAY</b>	Error 0020 EXIO Not Found
<b>CAUSE</b>	The I/O board inside RINGWIDE is not recognized.
<b>COUNTERMEASURES</b>	Turn the power off and then restart the RINGWIDE. If that doesn't fix the problem, contact the office listed in this manual or the point of purchase for this product.

<b>DISPLAY</b>	Error 0021 Main board Malfunctioning
<b>CAUSE</b>	The main board does not recognize itself.
<b>COUNTERMEASURES</b>	Contact the office listed in this manual or the point of purchase for this product.

<b>DISPLAY</b>	Error 0022 Game Program Not Found on Storage Device
<b>CAUSE</b>	There is no game program on the storage device.
<b>COUNTERMEASURES</b>	Use the installation media (DVD DRIVE, etc.) to reinstall the game.

<b>DISPLAY</b>	Error 0023 - 0026 Main board Malfunctioning
<b>CAUSE</b>	Failed to access the main board.
<b>COUNTERMEASURES</b>	Turn the power off and then restart the RINGWIDE. If that doesn't fix the problem, contact the office listed in this manual or the point of purchase for this product.

<b>DISPLAY</b>	Error 0027 Low Battery
<b>CAUSE</b>	The button battery may be depleted.
<b>COUNTERMEASURES</b>	Replace the button battery.

<b>DISPLAY</b>	Error 0041 Game Program Not Found on Install Media
<b>CAUSE</b>	There is no game program on the install media.
<b>COUNTERMEASURES</b>	Check that the game program, place on the install media (DVD DRIVE etc.), and the key chip correspond to each other.



<b>DISPLAY</b>	Error 0042 Game Program Not Found on Install Media
<b>CAUSE</b>	Some part of the game program is missing.
<b>COUNTERMEASURES</b>	Check how the game was installed. If that doesn't fix the problem, contact the office listed in this manual or the point of purchase for this product.

<b>DISPLAY</b>	Error 0049 Install Media Access Failed
<b>CAUSE</b>	Failed to access the install media.
<b>COUNTERMEASURES</b>	Check that the install media (DVD DRIVE etc.) is connected correctly. Check that the game disk is not scratched, damaged or dirty. If that doesn't fix the problem, contact the office listed in this manual or the point of purchase for this product.

<b>DISPLAY</b>	Error 0052 Install Media Access Failed
<b>CAUSE</b>	Failed to access the install media.
<b>COUNTERMEASURES</b>	Check that the install media (DVD DRIVE etc.) is connected correctly. Check that the game disk is not scratched, damaged or dirty. If that doesn't fix the problem, contact the office listed in this manual or the point of purchase for this product.

<b>DISPLAY</b>	Error 0055 Game Program Verify Error
<b>CAUSE</b>	The installed game program is not working correctly.
<b>COUNTERMEASURES</b>	Turn the power off and then restart the RINGWIDE. If that doesn't fix the problem, contact the office listed in this manual or the point of purchase for this product.

<b>DISPLAY</b>	Error 0064 Game Program Not Found on Server
<b>CAUSE</b>	No game program on the LAN install server.
<b>COUNTERMEASURES</b>	Check that the game program, place on the LAN install server, and the key chip correspond to each other.

<b>DISPLAY</b>	Error 0066 Game Program Verify Error
<b>CAUSE</b>	The installed game program is not working correctly.
<b>COUNTERMEASURES</b>	Turn the power off and then restart the RINGWIDE. If that doesn't fix the problem, contact the office listed in this manual or the point of purchase for this product.

<b>DISPLAY</b>	Error 0081 Invalid Storage Format
<b>CAUSE</b>	The storage format is wrong.
<b>COUNTERMEASURES</b>	Contact the office listed in this manual or the point of purchase for this product.

<b>DISPLAY</b>	Error 0082 Game Program Access Failed
<b>CAUSE</b>	The storage device cannot be recognized.
<b>COUNTERMEASURES</b>	Reinstall the game program. If that doesn't fix the problem, contact the office listed in this manual or the point of purchase for this product.

<b>DISPLAY</b>	Error 0083 Storage Device Not Acceptable
<b>CAUSE</b>	The storage does not have enough space.
<b>COUNTERMEASURES</b>	Contact the office listed in this manual or the point of purchase for this product.

<b>DISPLAY</b>	Error 0084 Storage Device Malfunctioning
<b>CAUSE</b>	The storage device may be broken.
<b>COUNTERMEASURES</b>	Turn the power off and then restart the RINGWIDE. If that doesn't fix the problem, contact the office listed in this manual or the point of purchase for this product.

<b>DISPLAY</b>	Error 0085 Invalid Storage Format
<b>CAUSE</b>	The storage format is wrong.
<b>COUNTERMEASURES</b>	Contact the office listed in this manual or the point of purchase for this product.

<b>DISPLAY</b>	Error 0088 System Program Verify Error
<b>CAUSE</b>	The installed system program is not working correctly.
<b>COUNTERMEASURES</b>	Perform a manual recovery of RINGWIDE. If that doesn't fix the problem, contact the office listed in this manual or the point of purchase for this product.

<b>DISPLAY</b>	Error 0090 High CPU Temperature
<b>CAUSE</b>	The CPU temperature is high.
<b>COUNTERMEASURES</b>	Refer to Chapter 7, and clean RINGWIDE. If that doesn't fix the problem, contact the office listed in this manual or the point of purchase for this product.

<b>DISPLAY</b>	Error 0091 Too High CPU Temperature
<b>CAUSE</b>	The CPU temperature is high.
<b>COUNTERMEASURES</b>	Refer to Chapter 7, and clean RINGWIDE. If that doesn't fix the problem, contact the office listed in this manual or the point of purchase for this product.

<b>DISPLAY</b>	Error 0501 - 0530 (No message)
<b>CAUSE</b>	The connected device cannot be recognized.
<b>COUNTERMEASURES</b>	Turn the power off and then restart the RINGWIDE. If that doesn't fix the problem, contact the office listed in this manual or the point of purchase for this product.

<b>DISPLAY</b>	Error 0531 (No message)
<b>CAUSE</b>	The connected graphics device cannot be recognized.
<b>COUNTERMEASURES</b>	Turn the power off and then restart the RINGWIDE. If that doesn't fix the problem, contact the office listed in this manual or the point of purchase for this product.

<b>DISPLAY</b>	Error 0532 (No message)
<b>CAUSE</b>	The connected USB device cannot be recognized.
<b>COUNTERMEASURES</b>	Check that the USB devices are connected correctly, and turn the power off and then restart the RINGWIDE. If that doesn't fix the problem, contact the office listed in this manual or the point of purchase for this product.

<b>DISPLAY</b>	Error 0533 - 0550 (No message)
<b>CAUSE</b>	The connected device cannot be recognized.
<b>COUNTERMEASURES</b>	Turn the power off and then restart the RINGWIDE. If that doesn't fix the problem, contact the office listed in this manual or the point of purchase for this product.

<b>DISPLAY</b>	Error 0901 Wrong Platform
<b>CAUSE</b>	The game board being used is not supported.
<b>COUNTERMEASURES</b>	Check to see if any game programs have been upgraded.

<b>DISPLAY</b>	Error 0902 Wrong System Program
<b>CAUSE</b>	It was started up with an unsupported system program. The RINGWIDE system program must be updated.
<b>COUNTERMEASURES</b>	Check how the game was installed. If that doesn't fix the problem, contact the office listed in this manual or the point of purchase for this product.

<b>DISPLAY</b>	Error 0903 Wrong Region.
<b>CAUSE</b>	The game is for a foreign region.
<b>COUNTERMEASURES</b>	Use a domestic game.

<b>DISPLAY</b>	Error 0905 Graphic Function Not Found
<b>CAUSE</b>	The RINGWIDE graphics function cannot be recognized.
<b>COUNTERMEASURES</b>	Check that the game program is compatible with the RINGWIDE. If it is, contact the office listed in this manual or the point of purchase for this product.

<b>DISPLAY</b>	Error 0906 Sound Function Not found
<b>CAUSE</b>	The RINGWIDE sound function cannot be recognized.
<b>COUNTERMEASURES</b>	Contact the office listed in this manual or the point of purchase for this product.

<b>DISPLAY</b>	Error 0907 Not Enough System Memory
<b>CAUSE</b>	RINGWIDE does not have enough memory.
<b>COUNTERMEASURES</b>	Contact the office listed in this manual or the point of purchase for this product.

<b>DISPLAY</b>	Error 0908 Not Enough SRAM
<b>CAUSE</b>	RINGWIDE does not have enough SRAM.
<b>COUNTERMEASURES</b>	Contact the office listed in this manual or the point of purchase for this product.

<b>DISPLAY</b>	Error 0909 Not Enough Storage Device
<b>CAUSE</b>	RINGWIDE does not have enough storage.
<b>COUNTERMEASURES</b>	Contact the office listed in this manual or the point of purchase for this product.

<b>DISPLAY</b>	Error 0910 Wrong Resolution Setting
<b>CAUSE</b>	The game does not support the current resolution settings.
<b>COUNTERMEASURES</b>	Change the DIP SW to the correct settings and restart the RINGWIDE.

<b>DISPLAY</b>	Error 0911 Wrong Horizontal/Vertical Setting.
<b>CAUSE</b>	The monitor horizontal/vertical settings are incorrect.
<b>COUNTERMEASURES</b>	Change the DIP SW to the correct settings and restart the RINGWIDE.

<b>DISPLAY</b>	Error 0949 Keychip Not Found
<b>CAUSE</b>	Failed to access the key chip.
<b>COUNTERMEASURES</b>	Check that the key chip is connected correctly.

<b>DISPLAY</b>	Error 6401 JVS I/O board is not connected to main board.
<b>CAUSE</b>	(1) The I/O board is not connected. (2) Unreliable connection between the game board and the I/O board.
<b>COUNTERMEASURES</b>	(1) Connect the I/O board to RINGWIDE. Check that the power cable is connected to I/O board. (2) Reconnect or replace the JVS cable that connects the I/O board to RINGWIDE.

<b>DISPLAY</b>	Error 6402 JVS I/O board does not fulfill the game spec.
<b>CAUSE</b>	The correct I/O board is not connected.
<b>COUNTERMEASURES</b>	Use an I/O board that provides the proper input/output for the game.

## GAME ERROR CODES

DISPLAY	Error 1001 There is an error in the COIN ASSIGNMENTS SETTINGS.
CAUSE	COIN ASSIGNMENTS SETTINGS are incorrect.
COUNTERMEASURES	Make sure “SYSTEM TEST MODE” > “COIN ASSIGNMENTS” > “COIN CHUTE TYPE” and “SERVICE TYPE” are both set to “COMMON.”

DISPLAY	Error 6001 Unable to recognize SEAT MOTOR DRIVE BD.(PITCH)
CAUSE	SEAT MOTOR DRIVE BD (PITCH) is not recognized.
COUNTERMEASURES	Check to make sure the test works under “GAME TEST MODE” > “CABINET SETTING” > “SEAT MOTION TEST.” If the test does not work, check the connection of the wires between the RINGWIDE and SEAT MOTOR DRIVE BD (PITCH) or replace them. If the test still does not work after replacing them, it is likely a faulty SEAT MOTOR DRIVE BD (PITCH). Contact your point of purchase or the office listed in this manual.

DISPLAY	Error 6002 SEAT MOTOR INITIALIZATION FAILED (PITCH)
CAUSE	SEAT MOTOR DRIVE BD (PITCH) is not recognized.
COUNTERMEASURES	Check to make sure the test works under “GAME TEST MODE” > “CABINET SETTING” > “SEAT MOTION TEST.” If the test does not work, check the connection of the wires between the RINGWIDE and SEAT MOTOR DRIVE BD (PITCH) or replace them. If the test still does not work after replacing them, it is likely a faulty SEAT MOTOR DRIVE BD (PITCH). Contact your point of purchase or the office listed in this manual.

DISPLAY	Error 6003 The SEAT MOTOR has overheated.(PITCH)
CAUSE	The SEAT MOTOR (PITCH) overheated.
COUNTERMEASURES	Turn the power off and restart it after the motor temperature drops. When doing this, remove anything that might obstruct the movement of the seat. If this error is displayed frequently, it is likely a faulty SEAT MOTOR DRIVE BD (PITCH) or SEAT MOTOR (PITCH). Contact your point of purchase or the office listed in this manual.

DISPLAY	Error 6004 The SEAT MOTOR is using abnormal encoder data.(PITCH)
CAUSE	There is an abnormality in the SEAT MOTOR (PITCH) encoder data.
COUNTERMEASURES	Make sure all the wires between the front and rear cabinets are connected. If the error is still displayed after a restart, it is likely a faulty wire between the SEAT MOTOR DRIVE BD (PITCH) and SEAT MOTOR (PITCH) or a faulty SEAT MOTOR DRIVE BD (PITCH) or SEAT MOTOR (PITCH). Contact your point of purchase or the office listed in this manual.

DISPLAY	Error 6005 An overcurrent has passed through the SEAT MOTOR.(PITCH)
CAUSE	There was an overcurrent in the SEAT MOTOR (PITCH).
COUNTERMEASURES	If the error is still displayed after a restart, it is likely a faulty SEAT MOTOR DRIVE BD (PITCH) or SEAT MOTOR (PITCH). Contact your point of purchase or the office listed in this manual.

DISPLAY	Error 6009 The SEAT VOLUME is abnormal.(PITCH)
CAUSE	There is something wrong with the SEAT VOLUME (PITCH).
COUNTERMEASURES	Refer to 14-1-1 “PITCH VOLUME ADJUSTMENT” and adjust the volume. If the error persists, it is likely a faulty volume. Replace the volume.

DISPLAY	Error 6011 Unable to recognize SEAT MOTOR DRIVE BD.(ROLL)
CAUSE	The SEAT MOTOR DRIVE BD (ROLL) is not recognized.
COUNTERMEASURES	Check to make sure the test works under “GAME TEST MODE” > “CABINET SETTING” > “SEAT MOTION TEST.” If the test does not work, check the connection of the wires between the RINGWIDE and SEAT MOTOR DRIVE BD (ROLL) or replace them. If the test still does not work after replacing them, it is likely a faulty SEAT MOTOR DRIVE BD (ROLL). Contact your point of purchase or the office listed in this manual.

DISPLAY	Error 6012 SEAT MOTOR INITIALIZATION FAILED (ROLL)
CAUSE	The SEAT MOTOR DRIVE BD (ROLL) is not recognized.
COUNTERMEASURES	Check to make sure the test works under “GAME TEST MODE” > “CABINET SETTING” > “SEAT MOTION TEST.” If the test does not work, check the connection of the wires between the RINGWIDE and SEAT MOTOR DRIVE BD (ROLL) or replace them. If the test still does not work after replacing them, it is likely a faulty SEAT MOTOR DRIVE BD (ROLL). Contact your point of purchase or the office listed in this manual.

DISPLAY	Error 6013 The SEAT MOTOR has overheated.(ROLL)
CAUSE	The SEAT MOTOR (ROLL) overheated.
COUNTERMEASURES	Turn the power off and restart it after the motor temperature drops. When doing this, remove anything that might obstruct the movement of the seat. If this error is displayed frequently, it is likely a faulty SEAT MOTOR DRIVE BD (ROLL) or SEAT MOTOR (ROLL). Contact your point of purchase or the office listed in this manual.

## Manual Recovery

Use the following procedure to return the RINGWIDE system software to a previous state.

- 1 Press the TEST and SERVICE Buttons simultaneously with the RINGWIDE power off.  
Hold the buttons down and turn on the power.
- 2 After RINGWIDE starts up and the following message is displayed, release the buttons.  
The system software will recover automatically. The Advertising screen will be displayed once everything finishes. Until it is displayed, do not interfere with the cabinet's operations.  
(If you are uninstalling a game, the Install Wait screen will be displayed.)

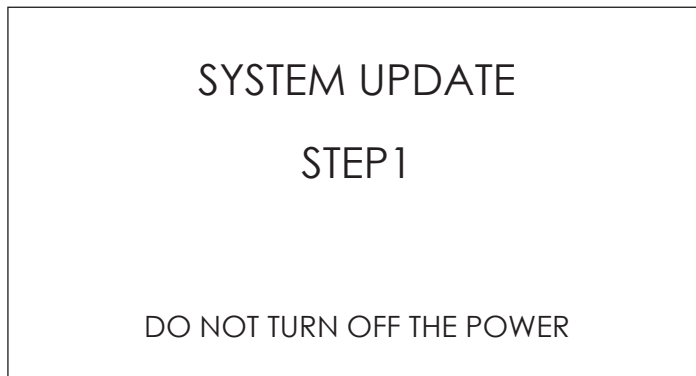

## 16-5 REPLACING THE BUTTON BATTERY

16

GAME BOARD

### WARNING

- Make sure you do not damage the printed board and wires. Such damage can lead to electric shock, short circuit and fire hazard.
- To prevent overheating, explosion, or fire:
  - Do not recharge, disassemble, heat, incinerate, or short the battery.
  - Do not allow the battery to come into direct contact with metallic objects or other batteries.
  - To preserve the battery, wrap it in tape or other insulating material.
- Follow local regulations when disposing of the battery. Improper disposal can damage the environment.
- Even the site maintenance personnel or other qualified professionals must not perform replacement operations for parts not described in this manual. In the event that such work is required either contact the office listed in this manual or first confirm the procedure with the place or office of purchase. Failure to do so may lead to electric shock or short circuit.
- Do not turn on the power with current carrying parts exposed. Doing so could result in electric shock or short circuit.

### CAUTION

To avoid risk of malfunction and damage:

- Make sure the positive and negative ends are aligned correctly.
- Use only batteries approved for use with this unit.

### IMPORTANT

- The batteries in RINGWIDE can be used for approximately 4 years of standard usage. If the battery appears to require replacement sooner than 4 years it is more likely that an error has occurred with some other part of the board. Rather than exchanging the battery requesting repair of the board itself may be more appropriate.
- Static electricity from your body may damage some electronics devices on the IC board. Before handling the IC board, touch a grounded metallic surface so that the static electricity can be discharged.



The button battery that require replacement can be found on the main board, inside the RINGWIDE shield case.

- 1 Remove the unit on which RINGWIDE is placed from the game cabinet.  
RINGWIDE must be removed still attached to the base (wooden shelf, etc.).
- 2 Remove 2 screws for the RINGWIDE lid. The screws are on top of the connector side.
- 3 Slide the lid toward the side with the connectors, and remove it.

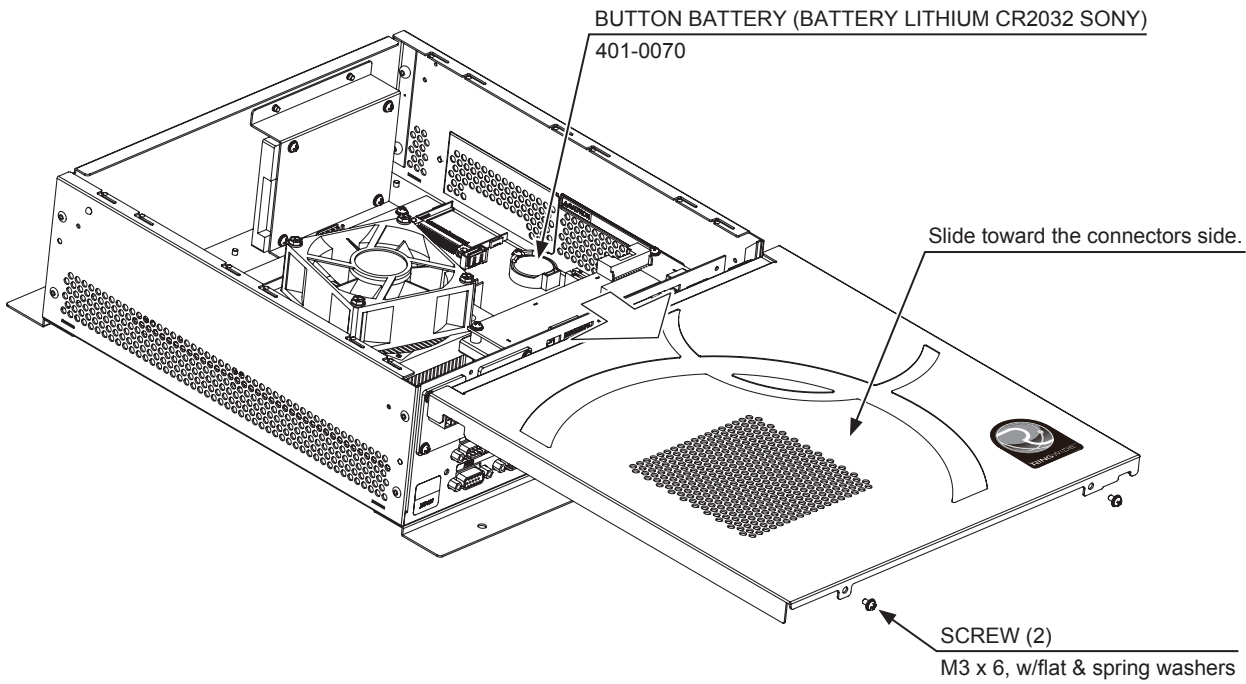

- 4 The main board is the board on the bottom of the RINGWIDE shield case.  
After replacing the main board's button battery, refer to Step 3 and close the lid.

## 16-6 CLEANING RINGWIDE

### STOP IMPORTANT

- Clean RINGWIDE once a year or whenever either “Error 0090” or “Error 0091” occurs. Dust accumulating in game boards may not function properly.
- Set each cabinet to correct settings after cleaning the product. Be sure to set RINGWIDE to correct settings when returning. If the proper settings are not used, the units may not function properly.

Once a year remove RINGWIDE from the cabinet and use a vacuum cleaner to clean around the RINGWIDE’s air vents and installation area.

1 Refer to the manual included with the game machine, and remove RINGWIDE from the cabinet.

2 Clean around the intake/exhaust vents of RINGWIDE with a vacuum cleaner.

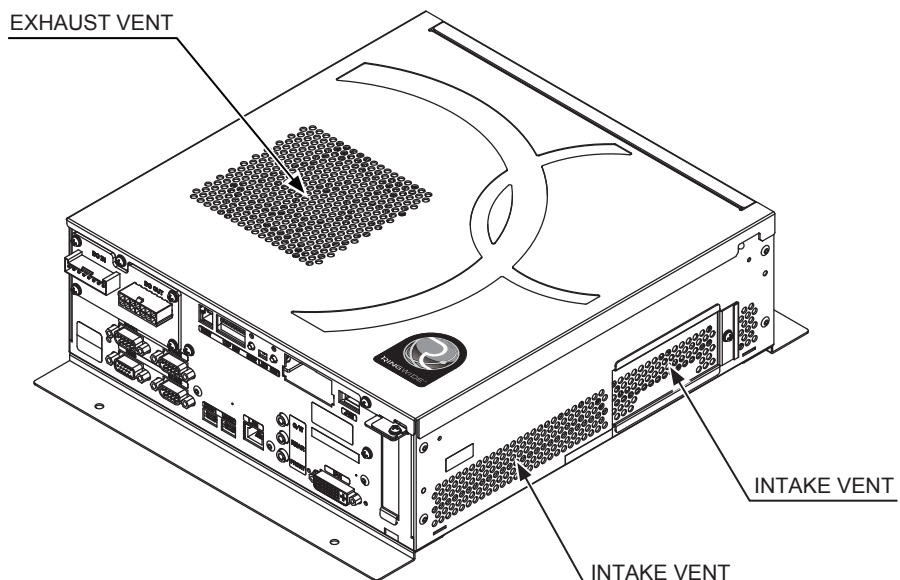
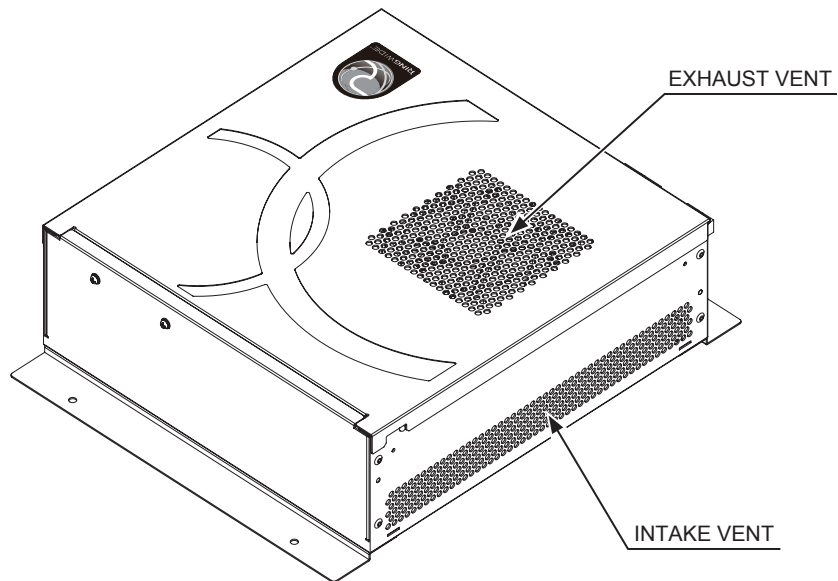

---

**3** Clean around installment parts of RINGWIDE in the cabinet with a vacuum cleaner. Be sure not to damage wirings and boards. Electronic devices on boards may damage by static electricity, and be sure not to vacuum electronic devices by a vacuum cleaner.

---

**4** Set each RINGWIDE you removed by the reverse method.

## 16-7 GAME BOARD (RINGWIDE) - LOCATION

16

GAME BOARD

### **⚠ WARNING**

- When returning the game board after making repairs or replacements, make sure that there are no errors in the connection of connectors. Erroneous connections can lead to electrical shock, short circuits or fires.
- When connecting a connector, check the direction carefully. Connectors must be connected in only one direction. If indiscriminate loads are applied in making connections, the connector or its terminal fixtures could be damaged, resulting in electrical shock, short circuits or fires.

**1** The machine is fitted with a Ringwide Game Board and several other Ancilliary Boards which are mainly housed inside the Display Cabinet. Only qualified Personnel should attempt to Service these Units.

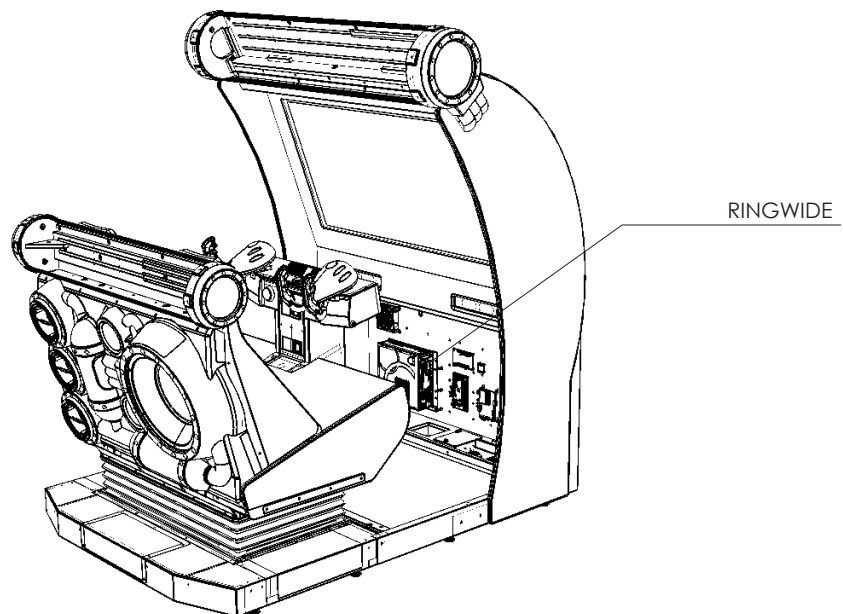

The Game Board Unit is located behind the front door of the main display cabinet. To remove, open the door using a key and security driver (TORX (T20)).

**2** Once the door has been removed and the RINGWIDE located, disconnect the VGA cable, USB cable, COMMS 1 and COMMS 2 and all power connections.

**3** Unscrew and remove the (4) phillips screws from each corner of the RINGWIDE whilst taking the weight and remove.

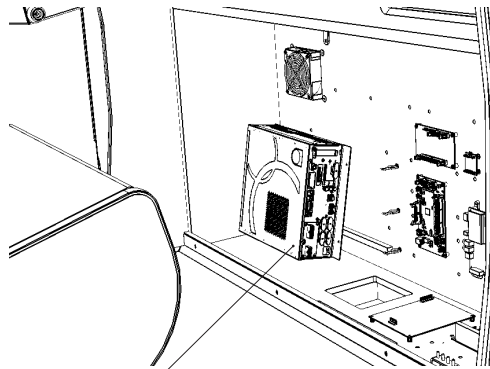
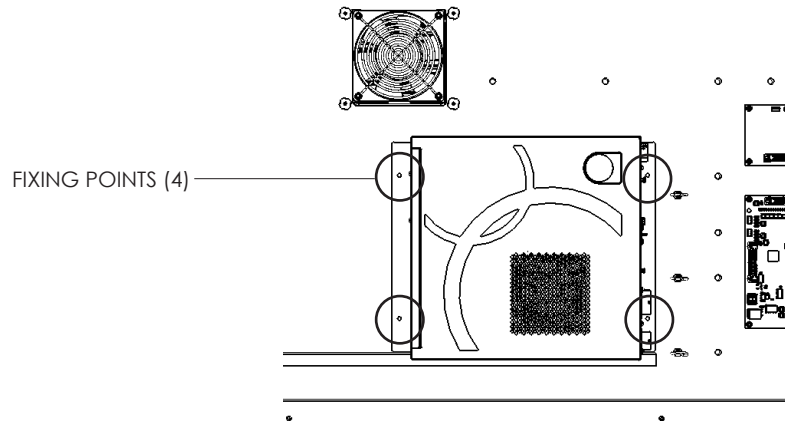

TAKE WEIGHT WHILST  
REMOVING FIXINGS

### **⚠ CAUTION**

Do not open the Game Board without the express permission of SEGA. If for any reason entry has been gained into the Game Board without the permission of SEGA, then all warranty rights become void.

When returning the Game Board to SEGA for service, then please make sure that adequate packaging is used as damage in transit make occur.

# 17 DESIGN-RELATED PARTS

For the warning display stickers, refer to Section 1.

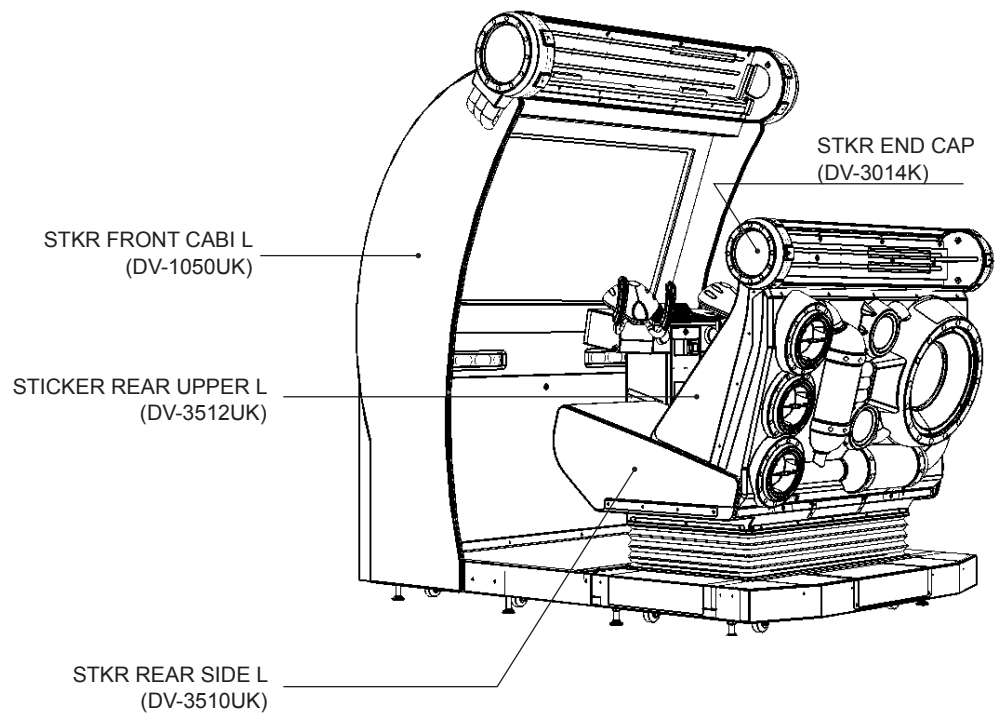
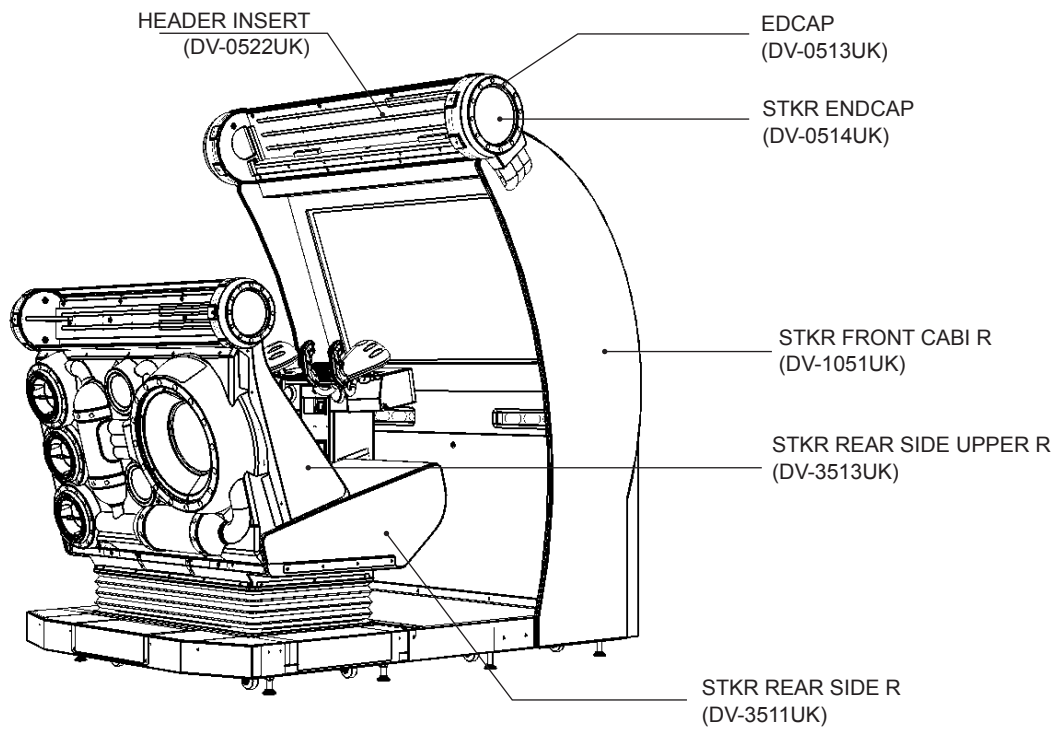

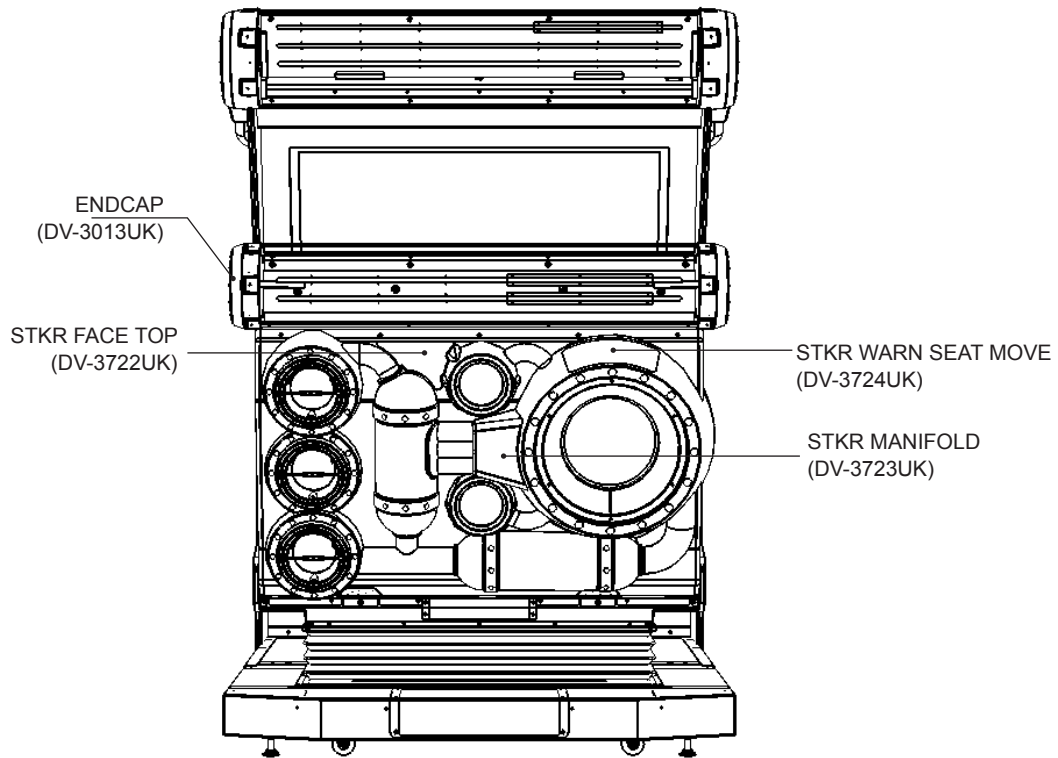
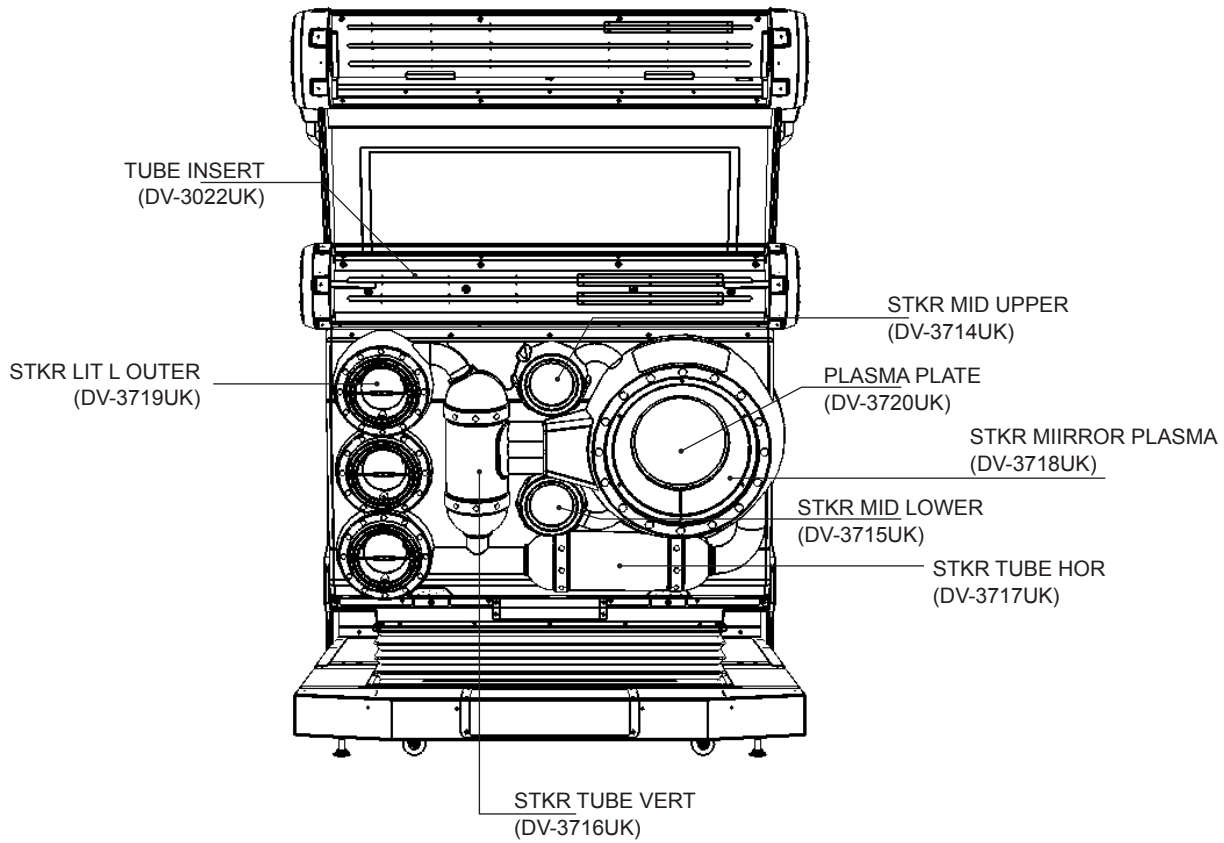

# 18 PARTS LIST

## ASSY TOP DREAM RAIDERS STRUCTURE

18

PARTS LIST

TOP ASSY DREAM RAIDERS BOM STRUCTURE

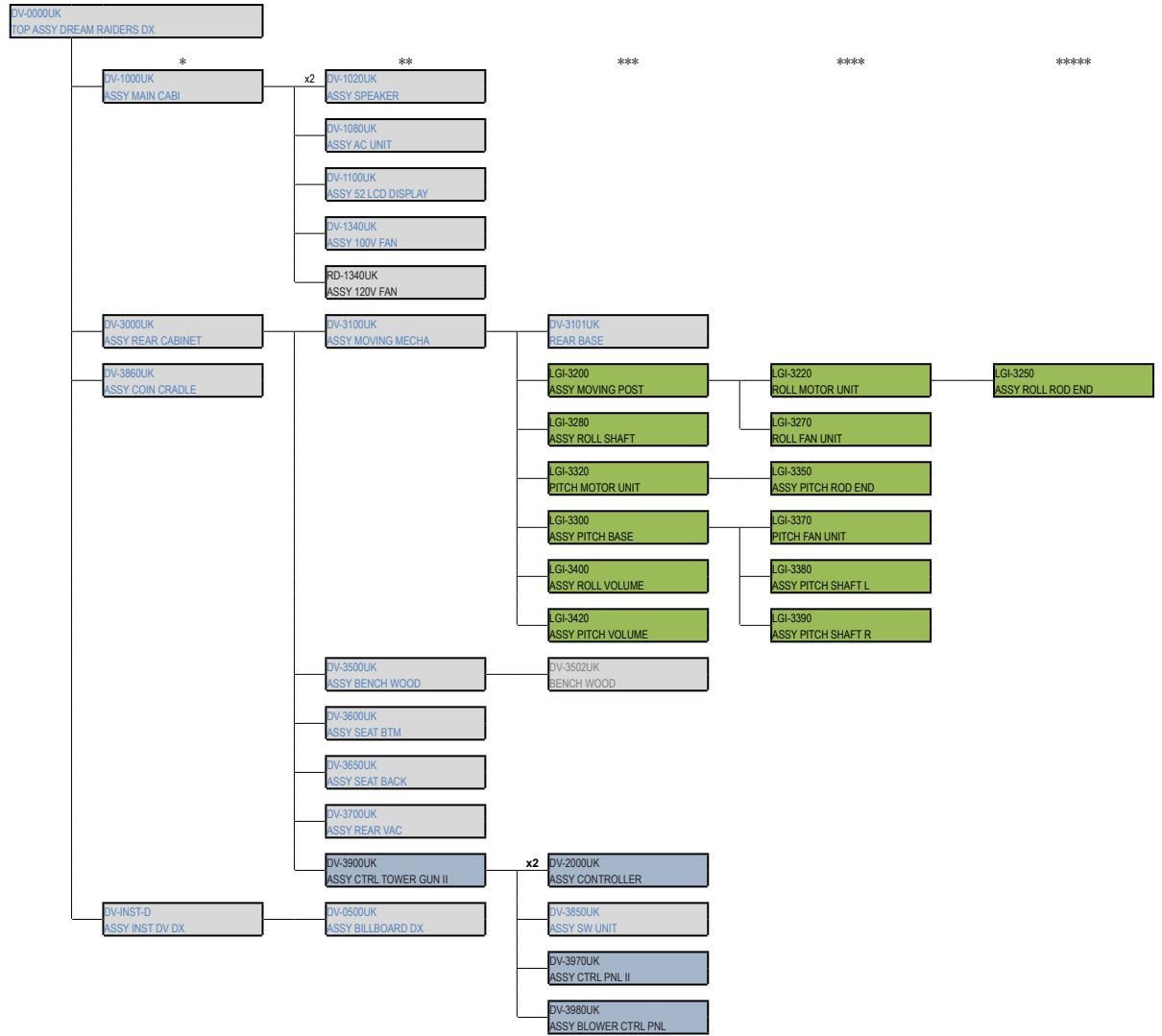



# ① ASSY TOP DREAM RAIDER (DV-0000UK)

(D-1/2)

ITEM NO	PART NO	DESCRIPTION	QTY
*1	DV-1000UK	ASSY MAIN CABI	1
*2	DV-3000UK	ASSY REAR CABINET	1
*4	DV-3860UK	ASSY COIN CRADLE	1
*6	421-7988-91UK	STICKER SERIAL NUMBER UK	2
*12	421-7020UK	STICKER CAUTION FORK	4
*17	LB1102	STICKER DANGEROUS VOLTAGE	3
*18	LB1046	LABEL TESTED FOR ELEC. SAFETY	1
*20	LB1130	LABEL WEEE WHEELIE BIN	1
*101	560-LBGH-01UK	XFMR LBGH 230-100 8A	1
*203	050-F00400	M4 NUT FLG SER PAS	4
*401	DV-INST-D	ASSY INST DV DX	1
*410	PK0483	PALLET DV DX	1
*411	PK0484	SHRINK WRAP DV DX	1

① ASSY TOP DREAM RAIDER (DV-0000UK)

(D-2/2)

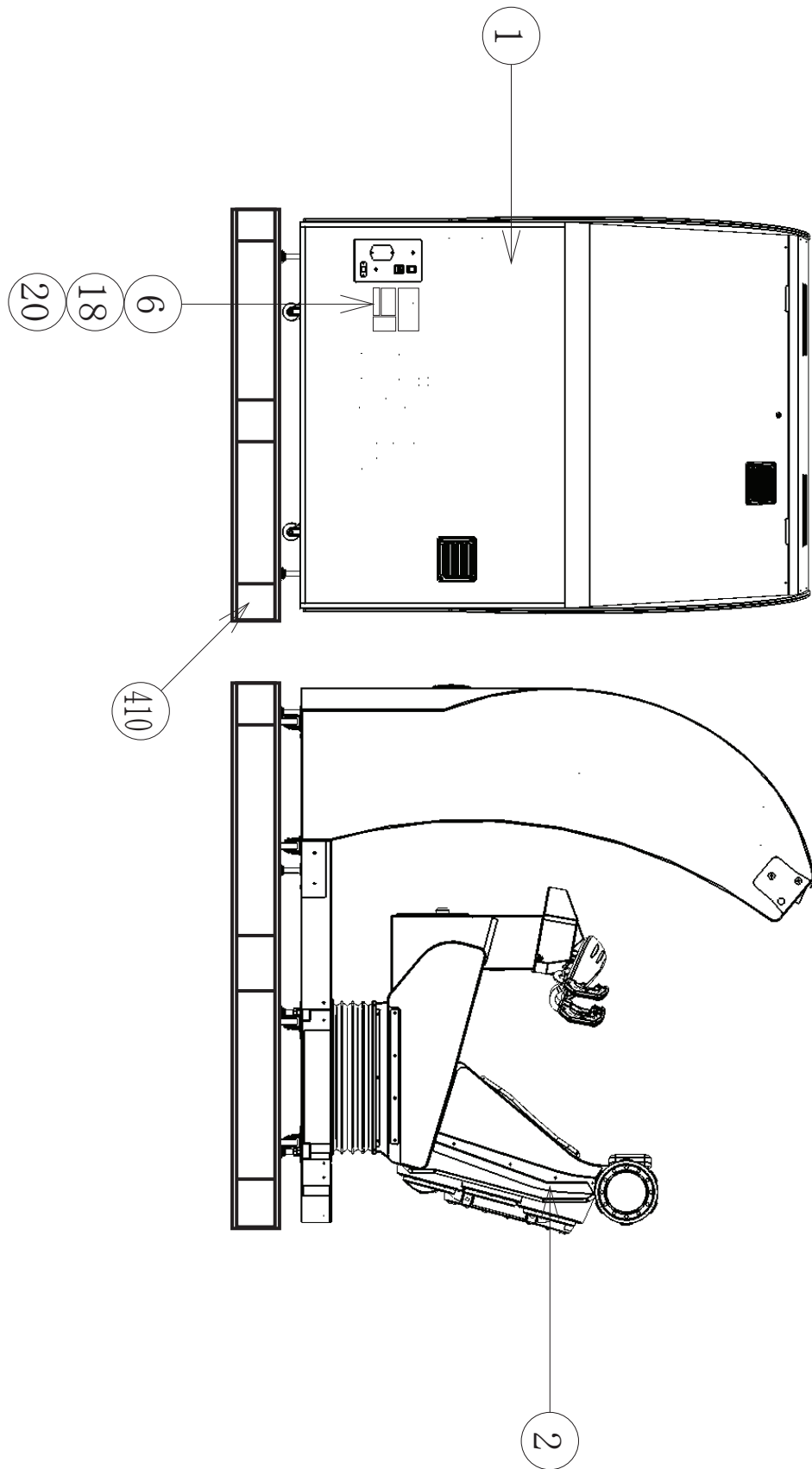

## ② ASSY BILLBOARD (DV-0500UK)

(D-1/2)

ITEM	PART NO	DESCRIPTION	QTY
***1	DV-0501UK	BILLBOARD ENCLOSURE DV	1
***2	DV-0511UK	TUBE BILLBOARD	1
***4	DV-0515UK	SASH TUBE FRONT	1
***5	DV-0516UK	SASH TUBE REAR	1
***6	DV-0522UK	TUBE HEADER INNER INSERT	1
***7	SSR-1225UK	LIGHT COVER CHEEK SHORT	4
***106	390-2012-RGB	LED STRIP RGB	3.6
***201	029-B00412-0B	M4X12 SKT BH BLK	8
***202	060-S00400-0B	M4 WSHR SPR BLK	12
***203	068-441616-0B	M4 WSHR 16OD FLT BLK	20
***204	000-F00412	M4X12 MSCR CSK PAS	8
***205	000-F00420	M4X20 MSCR CSK PAS	4
***206	060-F00400	M4 WSHR FORM A FLT PAS	4
***207	029-B00425-0B	M4X25 SKT BH BLK	4
***208	012-P03516-F	N6 X 5/8 S/TAP PAN PAS	24
***301	DV-60037UK	WH LED BILLBOARD TOP	1
***302	BE-6001UK	ASSY LED CLIP	3

18

PARTS LIST

② ASSYBILLBOARD (DV-0500UK)

(D-2/2)

18

PARTS LIST

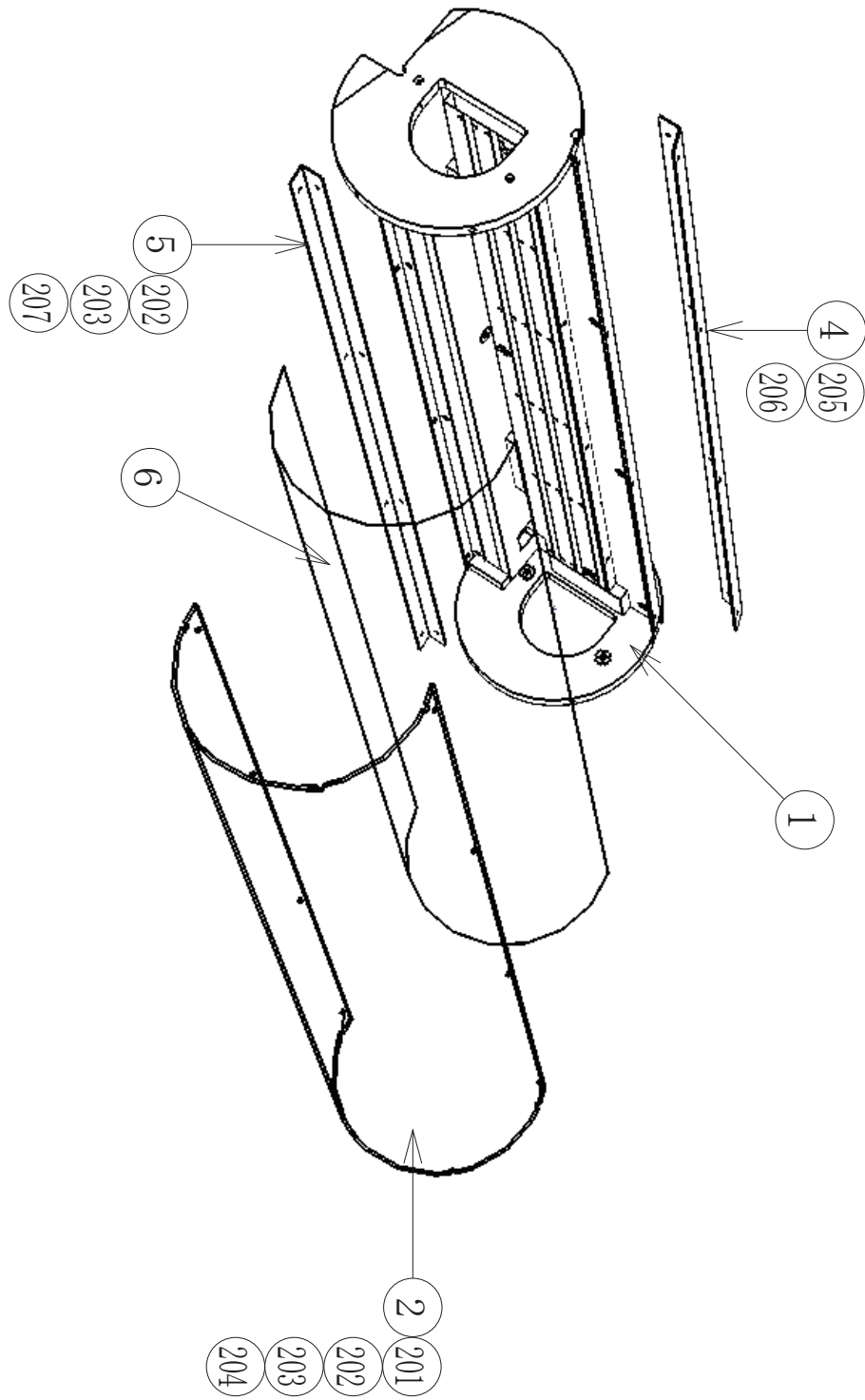

### ③ ASSY MAIN CABINET (DV-1000UK)

(D-1/2)

ITEM NO	PART NO	DESCRIPTION	QTY
**1	DV-1002UK	ASSY FRONT CABINET	1
**2	DV-1080UK	ASSY AC UNIT	1
**3	DV-1100UK	ASSY LCD DISPLAY	1
**4	DV-1020UK	ASSY SPEAKER	2
**10	DV-1340UK	ASSY 100V FAN	1
**11	RD-1340UK	ASSY 120V FAN	1
**12	DV-1002-DUK	PANEL 52 INCH LCD MOUNTING	2
**13	DV-1006UK	BRKT FRONT BRIDGE JOINT	2
**14	DV-1109UK	GLASS LCD 52 SCREEN PROTECT	1
**14	DV-1209UK	GLASS LCD 55 SCREEN PROTECT	1
**15	CFB-4003-01UK	EARTH PLATE	1
**50	DV-1050UK	STICKER FRONT CABI LH SIDE	1
**51	DV-1051UK	STICKER FRONT CABI RH SIDE	1
**101	847-0001D-02	ASSY CASE RINGWIDE 1GB EXP	1
**102	838-0005-XUK	FAN DRIVER BD	1
**104	838-0026UK	AMP 2.1 40W KEENE	1
**105	837-14572	I/O CONTROL BD 3 FOR JVS COM	1
**106	400-5483	SW REGU EADP-130CF A DELTA	1
**107	838-14551-02UK	AC DISTRIBUTION BD	2
**108	400-050-024-01	PSU 24VDC 50W MW LPS-50-24	1
**109	400-150-024-01	PSU 24VDC 150W MW LPS-150-24	1
**110	838-0022UK	SIGNAL INVERTER BRD	1
**111	FN1012	FAN GUARD METAL 120MM (FG-12)	1
**112	838-0012UK	LAMP DRIVER PCB (GUN RECOIL)	1
**113	253-5460-01	AIR VENT BLACK	2
**115	280-L00811-OS	STANDOFF 7.94OD 3.56ID 11.11L	4
**116	OS1011	PCB FEET	8
**117	EP1424	LED CONTROLLER	1
**118	280-L00640-WX	STANDOFF 6L WOOD X	4
**201	000-P00412	M4X12 MSCR PAN PAS	10
**202	060-S00400	M4 WSHR SPR PAS	28
**203	068-441616	M4 WSHR 16OD FLT PAS	24
**204	000-P00440	M4X40 MSCR PAN PAS	6
**205	000-P00425	M4X25 MSCR PAN PAS	20
**206	068-441616-0B	M4 WSHR 16OD FLT BLK	8
**207	030-000625	M6X25 BLT PAS	8
**208	060-S00600	M6 WSHR SPR PAS	16
**209	068-652016	M6 WSHR 20OD FLT PAS	16
**210	030-000625	M6X25 BLT PAS	8
**211	012-P00416-FZ	N8X5/8" S/TAP FLG 0Z	2
**212	012-P00325	N4X1" S/TAP PAN PAS	20
**213	012-P00312	N4X1/2" S/TAP PAN PAS	4
**214	012-P03512-F	N6X1/2" S/TAP FLG PAS	2
**301	DV-60002UK	WH AC 230 DIST	1
**302	DV-60003UK	WH AC 100 DIST	1
**303	DV-60004UK	WH AC FAN LCD	1
**304	DV-60005UK	WH DC OUT	1
**305	DV-60006UK	WH DC & BLOWER I/O	1

### ③ ASSY MAIN CABINET (DV-1000UK)

(D-2/2)

**306	DV-60008UK	WH I/O & AUDIO	1
**307	DV-60010UK	WH DC SERIAL OUT	2
**308	DV-60011UK	WH SPKR MAIN CAB	1
**309	DV-60039UK	WH BLOWER EXTN	1
**310	600-7158-0150UK	WH 3.5 JACK TO RCA	1
**311	600-7009-3000	ASSY RGB CA D-SUB 15	1
**312	600-7141-100UK	CABLE JVS TYPE A-B 100CM	1
**313	DV-60036UK	WH LED CONTROLLER	1
**314	DV-60035UK	WH LED CONTROL OUT	1

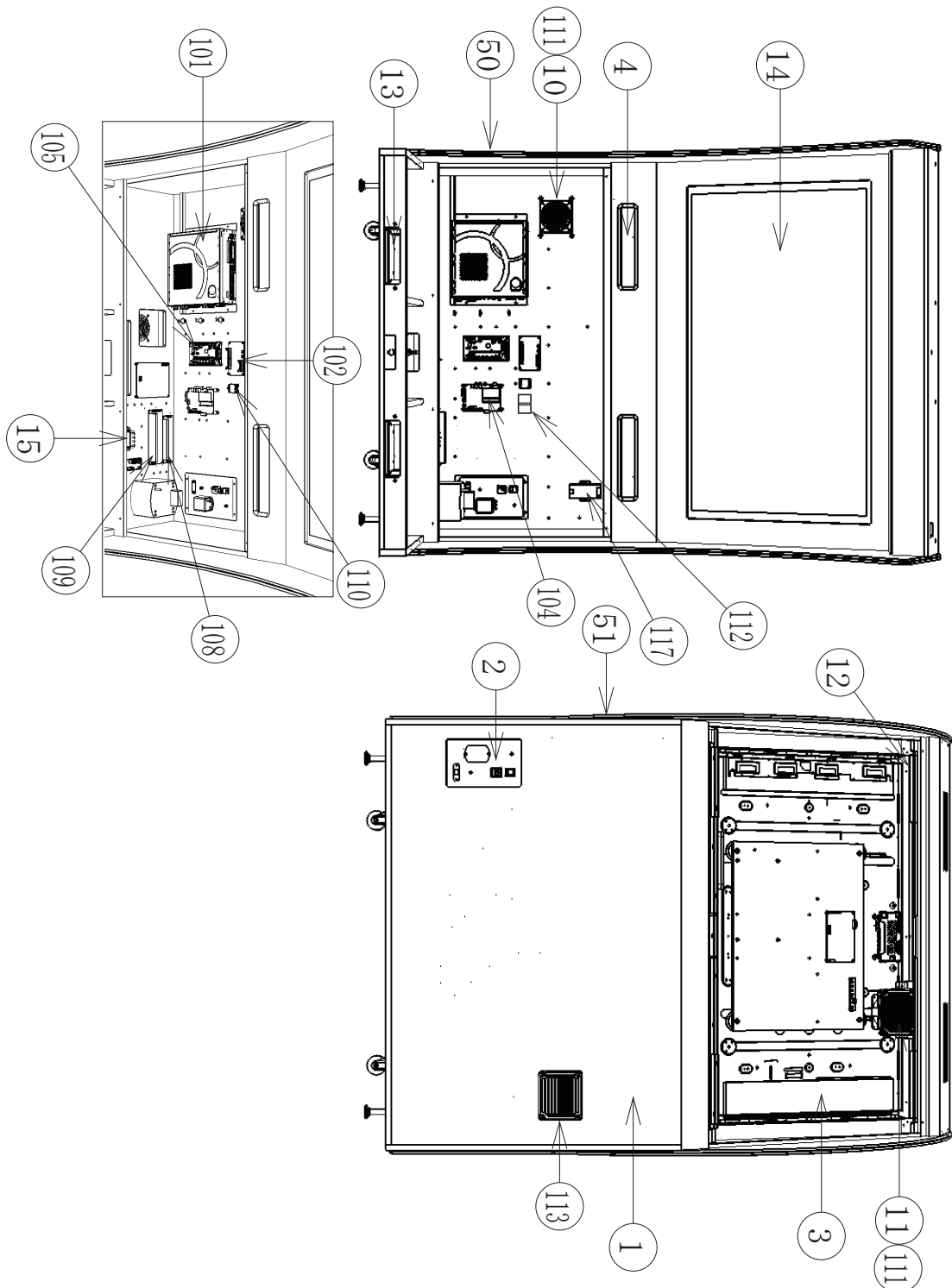

# ④ ASSY FRONT CABI (DV-1002UK)

(D-1/1)

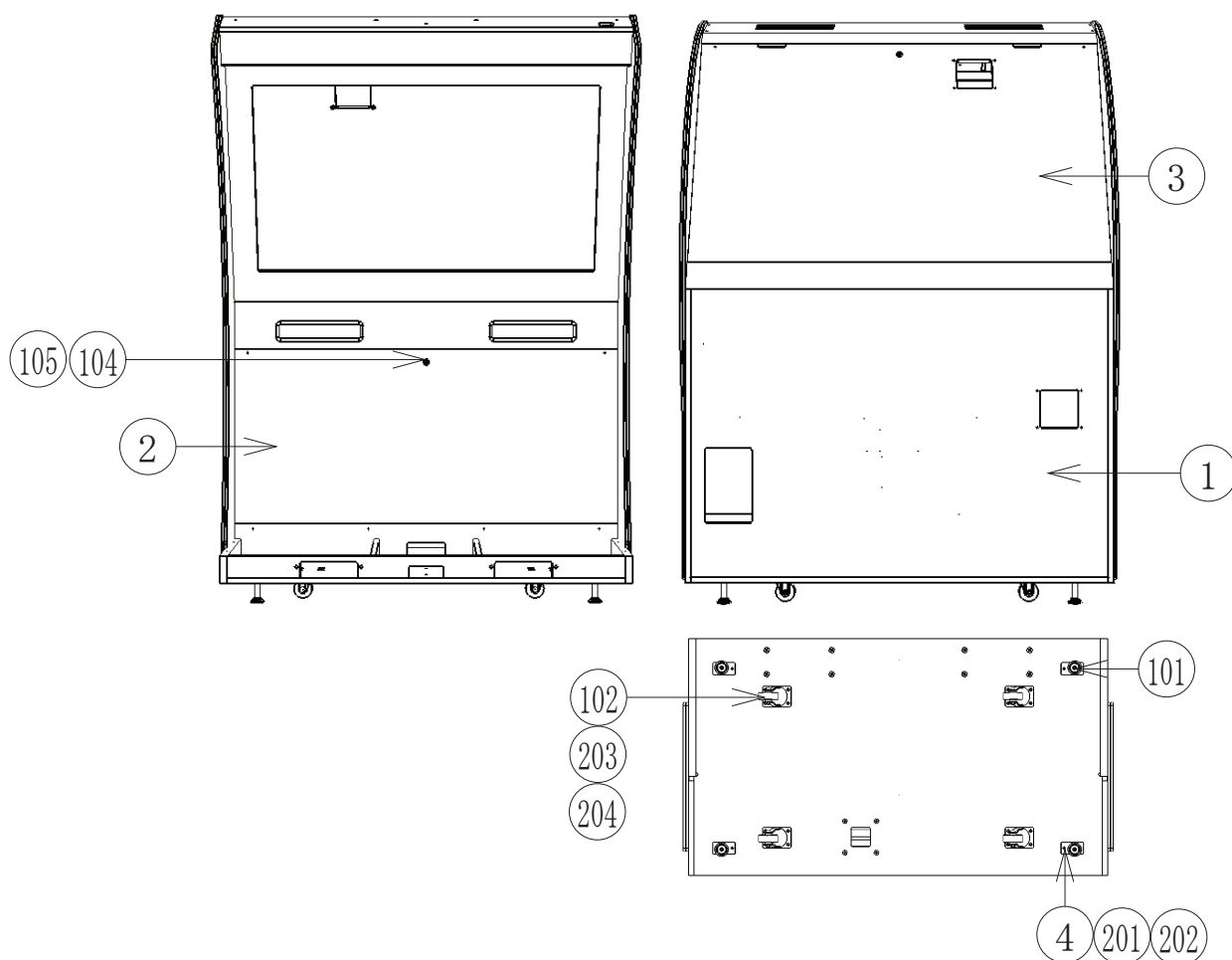

ITEM NO	PART NO	DESCRIPTION	QTY
***1	DV-1002-AUK	CABI BLANK	1
***2	DV-1002-BUK	DOOR FRONT	1
***3	DV-1002-CUK	DOOR BACK	1
***4	ADH-F0038UK	ADJUSTER PLATE	4
***101	601-5699UK-01	LEG ADJUSTER M16X100 1L/NUT	4
***102		CASTOR	4
***104		LOCK RADIAL PIN	2
***105	117-0062	PLATE LOCK RETAINER SPIKE WASH	2
***201	030-000625-S	M6X25 BLT W/S PAS	8
***202	050-F00600	M6 WSHR FORM A FLT PAS	8
***203	030-000825-S	M6X25 BLT W/S PAS	16
***204	050-F00680	M8 WSHR FORM A FLT PAS	16

⑤ ASSY SPEAKER (BE-1020UK)

(D-1/1)

18

PARTS LIST

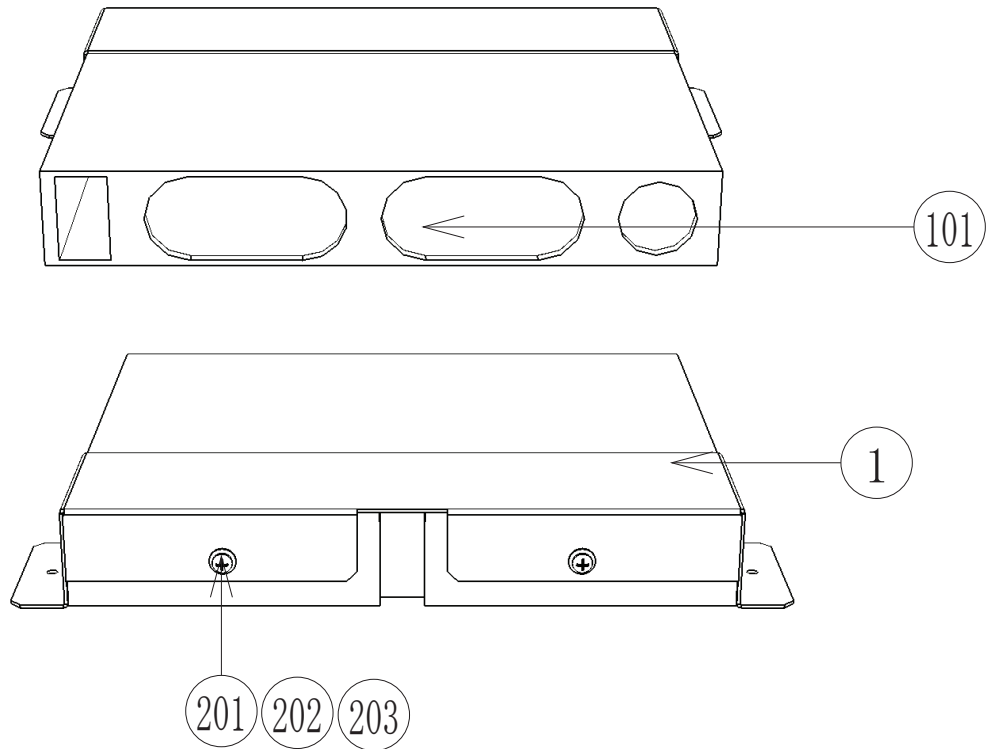

ITEM NO	PART NO		
***1	DV-1027UK	BRKT SPEAKER MOUNT	1
***101	130-5156-02-91	SPEAKER BOX 8OHM 20W VA1 YL	1
***201	030-000512	M5X12 BLT PAS	2
***202	060-S00500	M5 WSHR SPR PAS	2
***203	068-551616	M5 WSHR 16OD FLT PAS	2



⑥ ASSY AC UNIT (DV-1080UK)

(D-1/1)

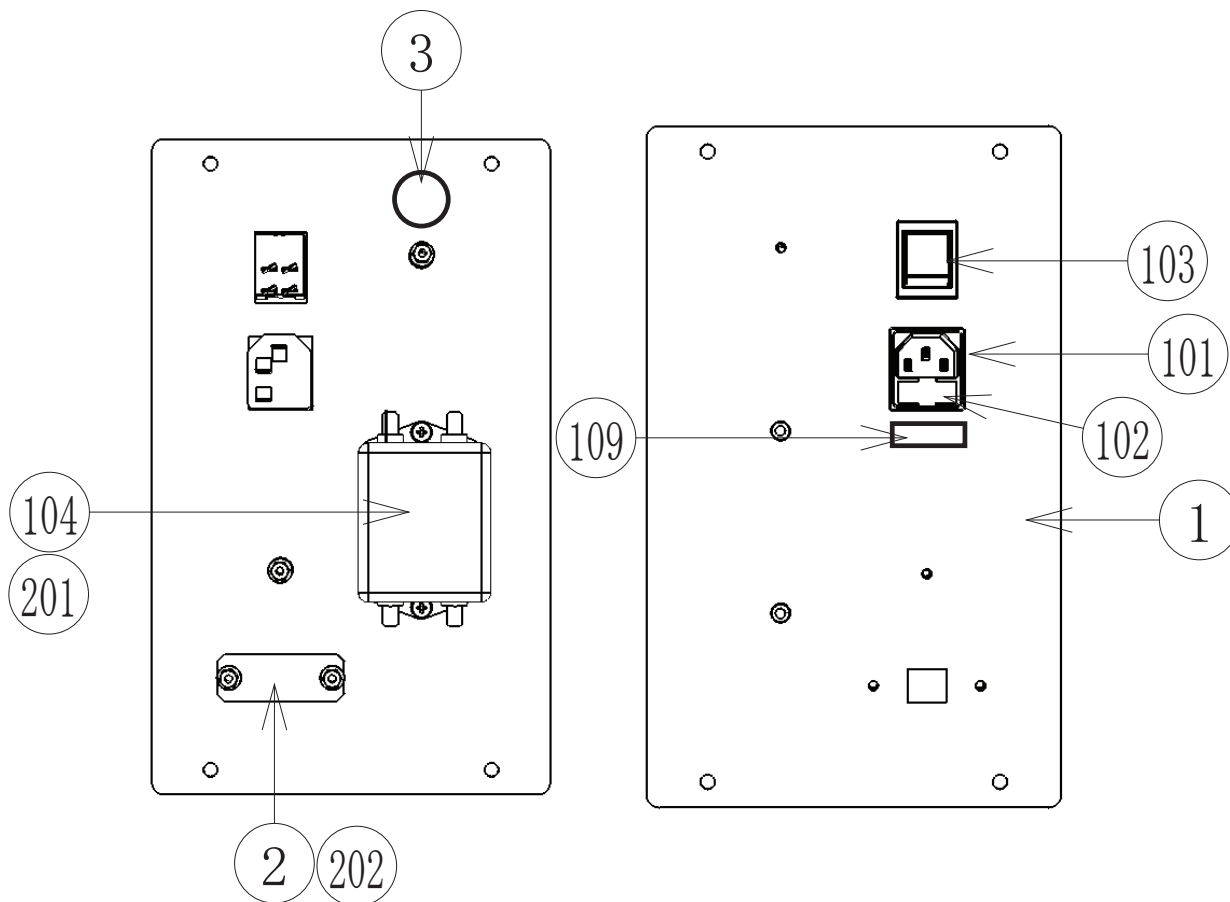

ITEM NO	PART NO	DESCRIPTION	QTY
***1	DV-1081UK	PLATE AC	1
***2	ST-0403UK	PLATE AC CAP	1
***3	LB1096	STICKER PROTECTIVE EARTH	1
***101	EP1302	EUROSOCKET FUSED 10A 250VAC	1
***102	514-5078-5000	FUSE 5X20 CERAMIC SB 5000mA	2
***103	SW1109	SWITCH ROCKER 250V AC	1
***104	EP1419	FILTER SCHAFFNER 2030-16-06	1
***108	310-5029-D508	HEAT SHRINK SLEEVING 50.8DIA	4
***109	LB1126-5-250	FUSE LABEL 5A 250V	1
***201	000-P00308-W	M3X8 MSCR PAN W/FS PAS	2
***202	050-F00400	M4 NUT FLG SER PAS	4
***301	DV-60001UK	WH AC IN	1

⑦ ASSY LCD DISPLAY 52"/55" (DV-1100UK/DV-1200UK)

(D-1/1)

18

PARTS LIST

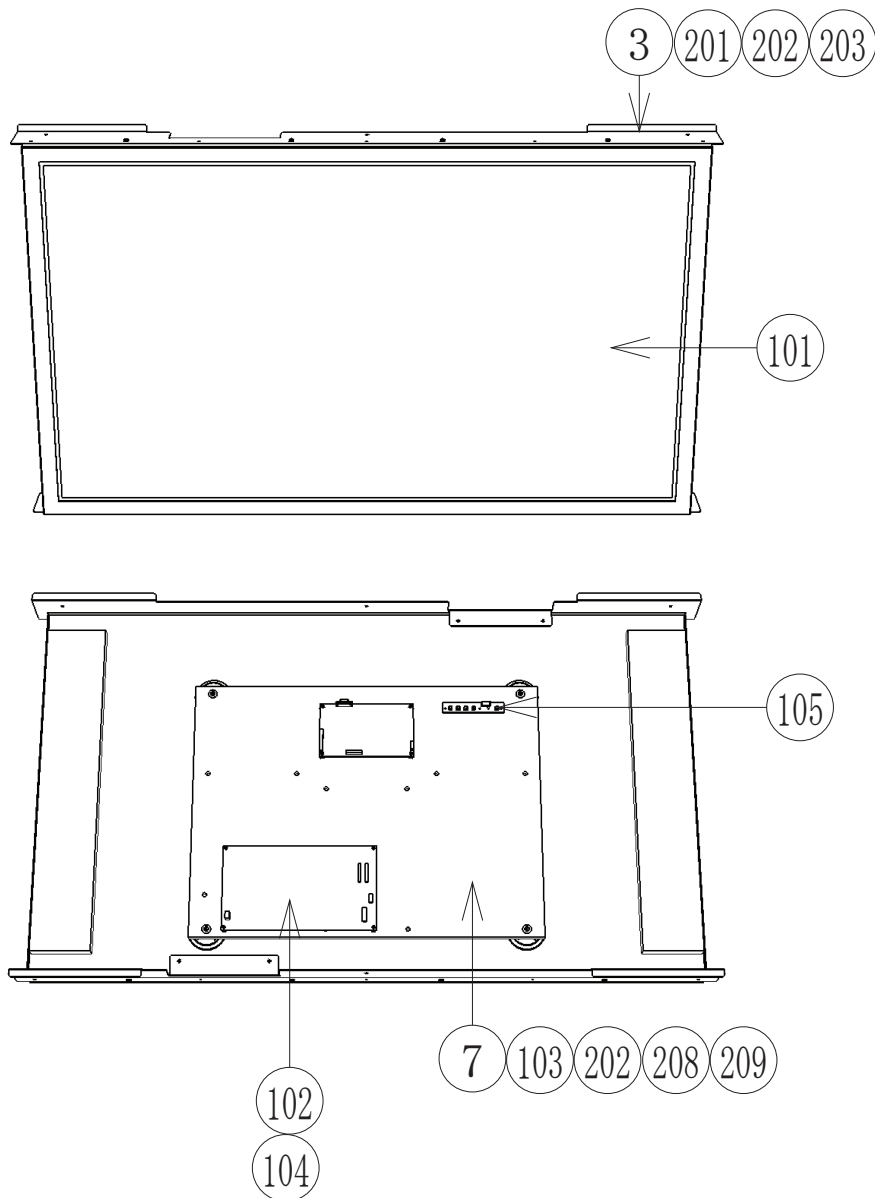

ITEM NO	PART NO	DESCRIPTION	QTY
***3	DV-1106UK	BRKT LCD MOUNT	2
***7	LGI-1110UK	PANEL PRISMA BD MOUNT	1
***101	200-6052-SMSNG	DISPLAY 52" LCD SAM LT1520HB02	1
***101	200-6055-SMSNG	DISPLAY 55" LCD SAM LT1520HB02 (USA/ASIA)	1
***102	400-356-024-01	PSU 52 LCD PVP-3680	1
***103	280-A01264-WX	ROUTER TWIST D12 SO6.4 WOOD X	4
***104	280-L00640-WX	STANDOFF 6MM 4 HOLE WOOD XL	8
***105	280-L00811-OS	STANDOFF 7.94OD 3.56ID 11.11L	3
***201	000-P00412	M4X12 MSCR PAN PAS	8
***202	060-S00400	M4 WSHR SPR PAS	12
***203	060-F00400	M4 WSHR FORM A FLT PAS	8
***208	000-P00416	M4X16 MSCR PAN PAS	4
***209	068-441616	M4 WSHR 16OD FLT PAS	4
			1

⑧ ASSY CONTROLLER (DV-2000UK)

(D-1/1)

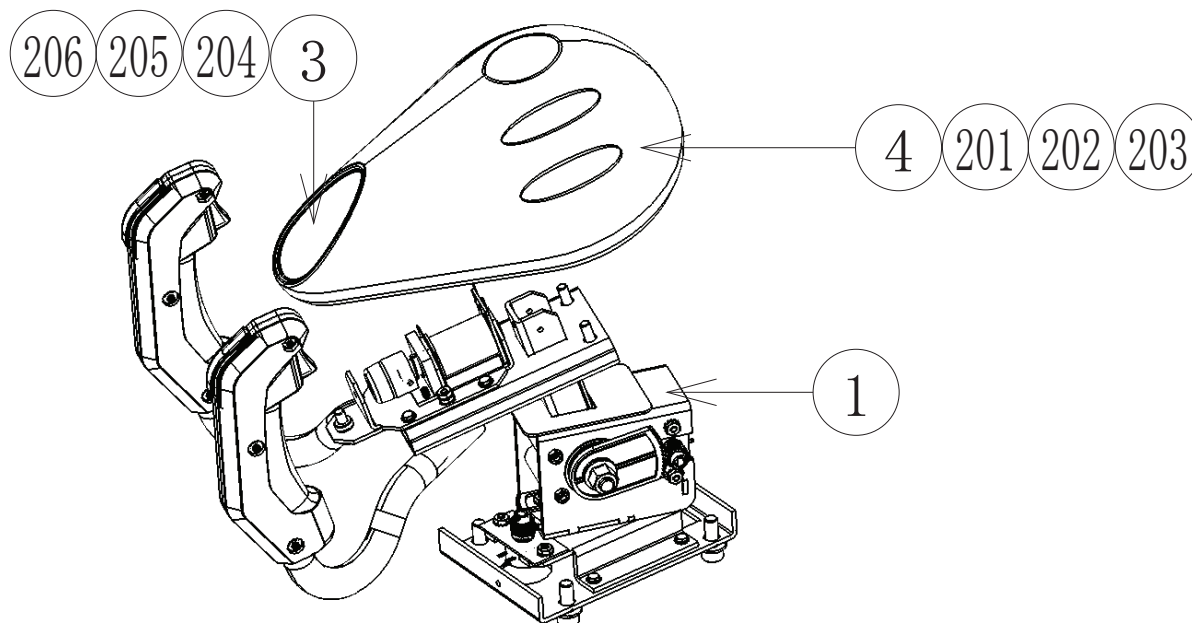

ITEM NO	PART NO	DESCRIPTION	QTY
***1	DV-2001-01UK	CONT CHASSIS W/BLK HANDLE	1
***2	DV-2002UK	BRKT LIGHT MTG INTERNAL	1
***3	DV-2003UK	STKR GUN BACK	1
***4	DV-2004UK	CONT COVER	1
***101	601-0460-0W	CABLE TIE WHT 100MM	1
***102	390-2012-RGB	LED FLEX STRIP RGB	0.05
***201	020-000616-OZ	M6X16 SKT CAP OZ	3
***202	060-S00600	M6 WSHR SPR PAS	3
***203	060-F00600	M6 WSHR FORM A FLT PAS	3
***204	020-000512-OZ	M5X10 SKT CAP OZ	2
***205	060-S00500	M5 WSHR SPR PAS	2
***206	060-F00500	M5 WSHR FORM A FLT PAS	2
***301	DV-60041UK	WH GUN INTERFACE	1
***302	BE-6001UK	ASSY LED CLIP	1

⑨ ASSY FAN (DV-1340UK)

(D-1/1)

18

PARTS LIST

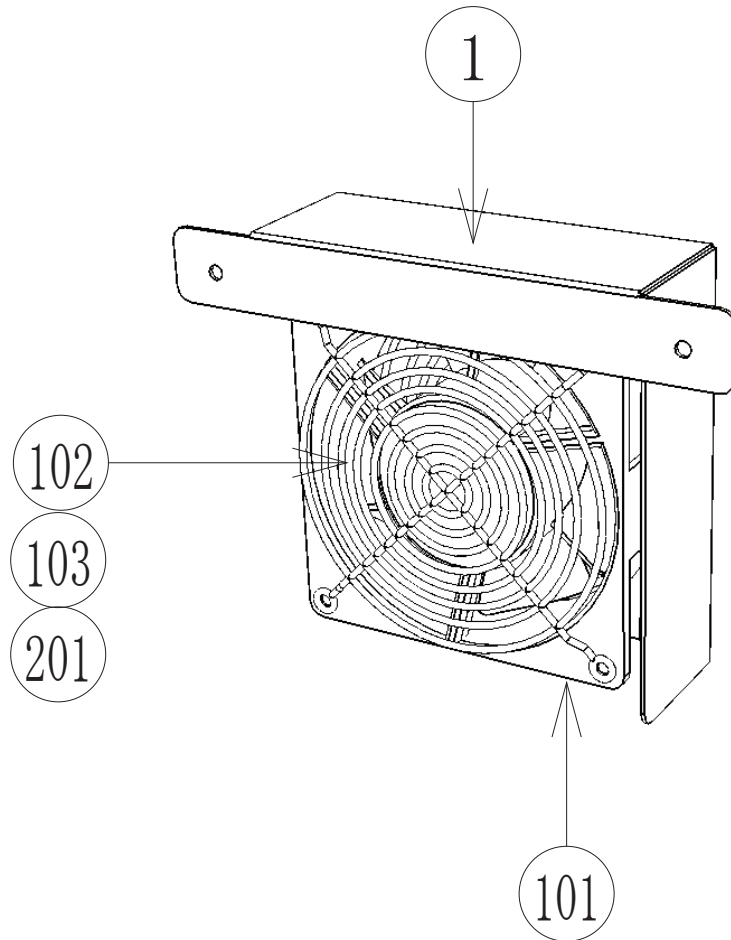

ITEM NO	PART NO	DESCRIPTION	QTY
***1	GST-1008UK	BRKT FAN	1
***101	260-0011-02	FAN AC100V 50-60HZ (SP100A-1123 X 5T)	1
***102	FN1012	FAN GUARD METAL 120MM (FG-12)	2
***103	OS1195	RIVET SNAP SR-4080B	5
***201	000-P00312-W	M3X12 MSCR PAN W/FS PAS	3
***301	ST-60026UK	WH 240V FAN	1

⑩ ASSY REAR CABINET (DV-3000UK)

(D-1/3)

ITEM NO	PART NO	DESCRIPTION	QTY
**1	DV-3100UK	ASSY MOVING MECHA	1
**2	DV-3500UK	ASSY BENCH WOOD	1
**3	DV-3600UK	ASSY SEAT BTM	1
**4	DV-3650UK	ASSY SEAT BACK	1
**5	DV-3700UK	ASSY REAR VAC	1
**6	DV-3001UK	BELLOW UPPER BASE FRONT	1
**7	DV-3002UK	BELLOW UPPER BASE REAR	1
**8	DV-3003UK	BELLOW UPPER BASE HATCH	1
**9	DV-3005UK	BELLOW UPPER BRKT SHORT	2
**10	DV-3006UK	BELLOW UPPER BRKT LONG	2
**11	DV-3007UK	COVER BASE BD REAR	1
**12	DV-3008UK	STICKER COVER BASE BD	1
**21	DV-3900UK	ASSY CTRL TOWER II	1
**22	DV-3011UK	TUBE SEAT BACK	1
**23	DV-3012UK	ENDCAP INNER	2
**24	DV-3013UK	ENDCAP	2
**25	DV-3014UK	STICKER ENDCAP	2
**26	DV-3015UK	SASH TUBE FRONT	1
**27	DV-3016UK	SASH TUBE BACK	1
**30	DV-3019UK	SASH REAR VAC L	1
**31	DV-3020UK	SASH REAR VAC R	1
**32	DV-3021UK	HEADREST	1
**33	DV-3022UK	TUBE SEAT INNER INSERT	1
**34	DV-3023UK	BRKT SEAT CLOSING	1
**35	DV-3024UK	BRKT CALF CLOSING	2
**36	DV-3025UK	BRKT HOLDER PLASMA	1
**37	DV-3026UK	BRKT HOLDER HEADREST	2
**38	DV-3721UK	PLATE PLASMA INNER	1
**39	SSR-1225UK	LIGHT COVER CHEEK SHORT	4
**101	390-2201-01UK	PLASMA PLATE 12"	1
**102	390-2012-RGB	LED STRP RGB	2.4
**103	OS1230	FOAM STRIP 2mm X 10mm	1
**104	601-0460-RUK	CABLE TIE 100MM X 2M	0.5
**201	020-000820-0Z	M8X20 SKT CAP OZ	11
**202	060-S00800-0B	M8 WSHR SPR BLK	24
**203	068-852216-0B	M8 WSHR 22OD FLT BLK	28
**204	030-000630	M6X30 BLT PAS	6
**205	060-S00600-0B	M6 WSHR SPR BLK	15
**206	068-652016-0B	M6 WSHR 20OD FLT BLK	15
**207	029-B00840-0B	M8X40 SKT BH BLK	4
**208	029-B00630-0B	M6X30 SKT BH BLK	4
**209	029-B00820-0B	M8X20 SKT BH BLK	5
**210	012-P00416-FZ	N8X5/8" S/TAP FLG 0Z	2
**211	029-B00530-0B	M5X30 SKT BH BLK	14
**212	060-S00500-0B	M5 WSHR SPR BLK	34
**213	068-551616-0B	M5 WSHR 16OD FLT BLK	40

# ⑩ ASSY REAR CABINET (DV-3000UK)

(D-2/3)

18

PARTS LIST

**214	029-B00512-0B	M5X12 SKT BH BLK	22
**215	029-B00412-0B	M4X12 SKT BH BLK	18
**216	060-S00400-0B	M4 WSHR SPR BLK	28
**217	068-441616-0B	M4 WSHR 16OD FLT BLK	44
**218	030-000830	M8X30 BLT PAS	4
**219	030-000850	M8X50 BLT PAS	9
**220	000-F00412	M4X12 MSCR CSK PAS	8
**221	008-OS0412	M4X12 TMP PRF STN	10
**222	068-441616-0C	M4 WSHR 16OD FLT CRM	10
**223	029-B00425-0B	M4X25 SKT BH BLK	12
**224	030-000525	M5X25 BLT PAS	6
**225	000-P00425	M4X25 MSCR PAN PAS	2
**226	020-F00650-0Z	M6X50 SKT CSK OZ	4
**227	012-P03516-F	N6 X 5/8 S/TAP PAN PAS	24
**301	DV-60022UK	WH SEAT LEDS EXT	1
**302	DV-60023UK	WH SEAT LEDS	1
**303	DV-60027UK	WH PITCH ROLL POT	1
**304	DV-60029UK	WH AC 100 SEAT	1
**305	DV-60030UK	WH SERVO TO MOTOR P	1
**306	DV-60031UK	WH SERVO TO MOTOR R	1
**307	DV-60032UK	WH SERIAL SERVO BD	1
**310	DV-60034UK	WH SEAT LED POWER	1

⑩ ASSY REAR CABINET (DV-3000UK)

(D-3/3)

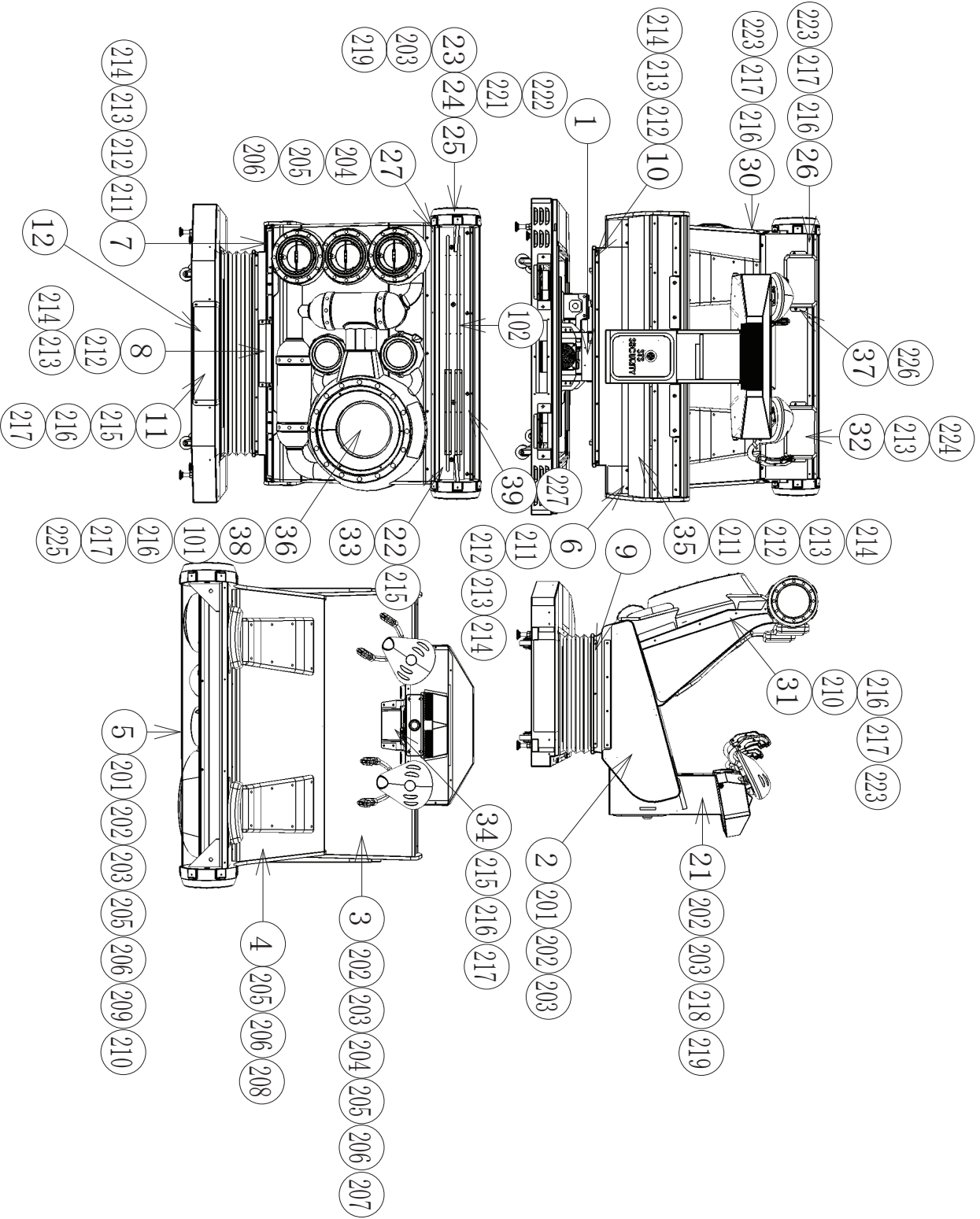

# ⑪ ASSY MOVING MECHA (DV-3100UK)

(D-1/2)

ITEM NO	PART NO	DESCRIPTION	QTY
***1	DV-3101UK	REAR BASE	1
***2	LGI-3200	ASSY MOVING POST	1
***3	LGI-3280	ASSY ROLL SHAFT	1
***4	LGI-3300	ASSY PITCH BASE	1
***5	LGI-3400	ASSY ROLL VOLUME	1
***6	LGI-3420	ASSY PITCH VOLUME	1
***12	LGI-3004	BELLOWS	1
***13	DV-3116UK	BELLOW LOWER BRKT FRONT	1
***14	DV-3117UK	BELLOW LOWER BRKT SIDE	2
***15	DV-3118UK	BELLOW LOWER BRKT REAR	1
***16	DV-3119UK	REAR TOP FRAME	1
***19	LGI-3202UK	ROLL VOL BASE	1
***21	LGI-3320	PITCH MOTOR UNIT	1
***101	838-15069	MOTOR DRIVE BD RS232/422	2
***201	020-000820-0Z	M8X20 SKT CAP OZ	52
***202	020-001440-0Z	M14X20 SKT CAP OZ	4
***203	060-S01400	M14 WSHR SPR PAS	4
***204	060-F01400	M14 WSHR FORM A FLT PAS	4
***207	000-P00320	M3X20 MSCR PAN PAS	8
***208	029-B00512-0B	M5X12 SKT BH BLK	18
***209	000-P00412	M4X12 MSCR PAN PAS	9
***210	060-S00400	M4 WSHR SPR PAS	9
***211	060-F00400	M4 WSHR FORM A FLT PAS	9
***212	060-S00800	M8 WSHR SPR PAS	52
***213	060-F00800	M8 WSHR FORM A FLT PAS	52
***214	060-S00500-0B	M5 WSHR SPR BLK	18
***215	068-551616-0B	M5 WSHR 16OD FLT BLK	18
***216	060-S00300	M3 WSHR SPR PAS	8
***217	060-F00300	M3 WSHR FORM A FLT PAS	8



⑪ ASSY MOVING MECHA (DV-3100UK)

(D-2/2)

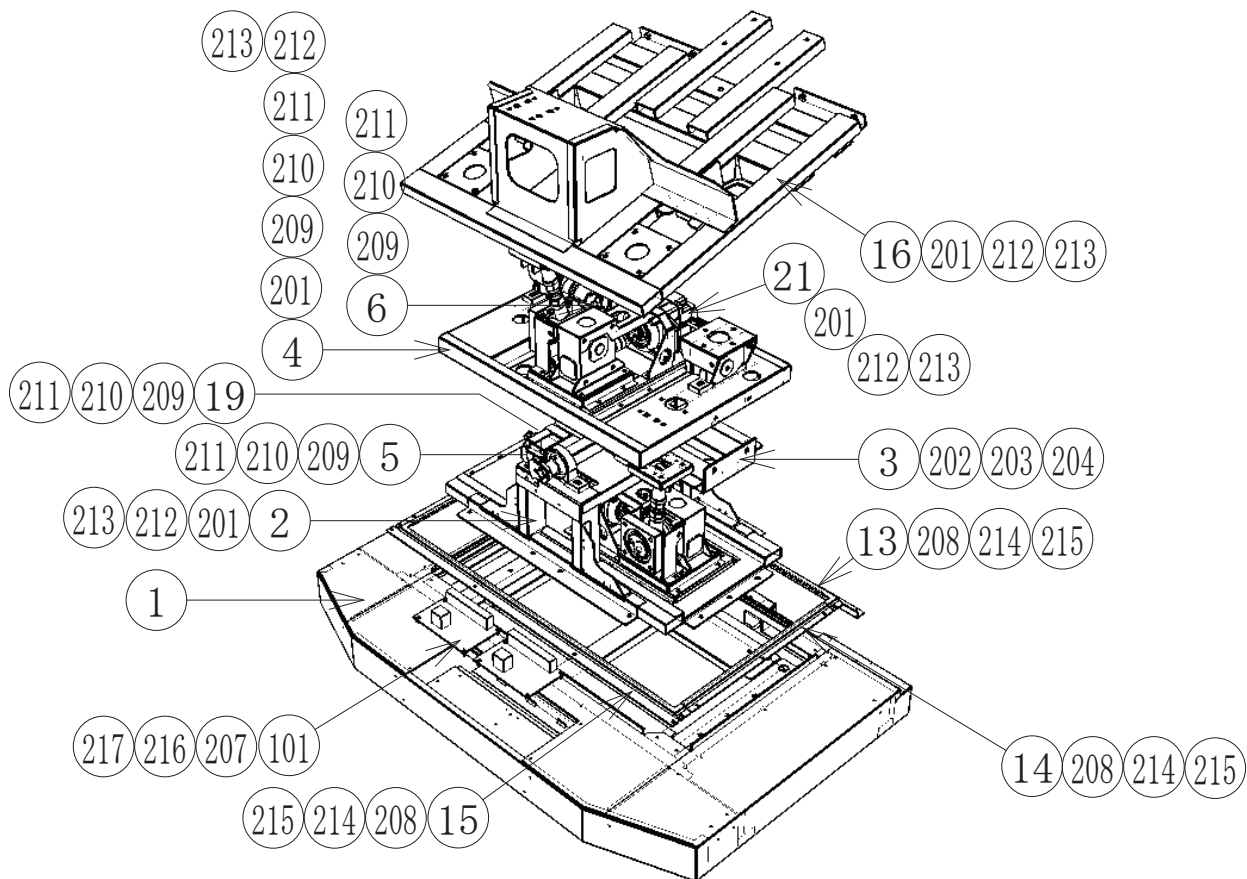

⑫ ASSY REAR BASE (DV-3101UK)

(D-1/1)

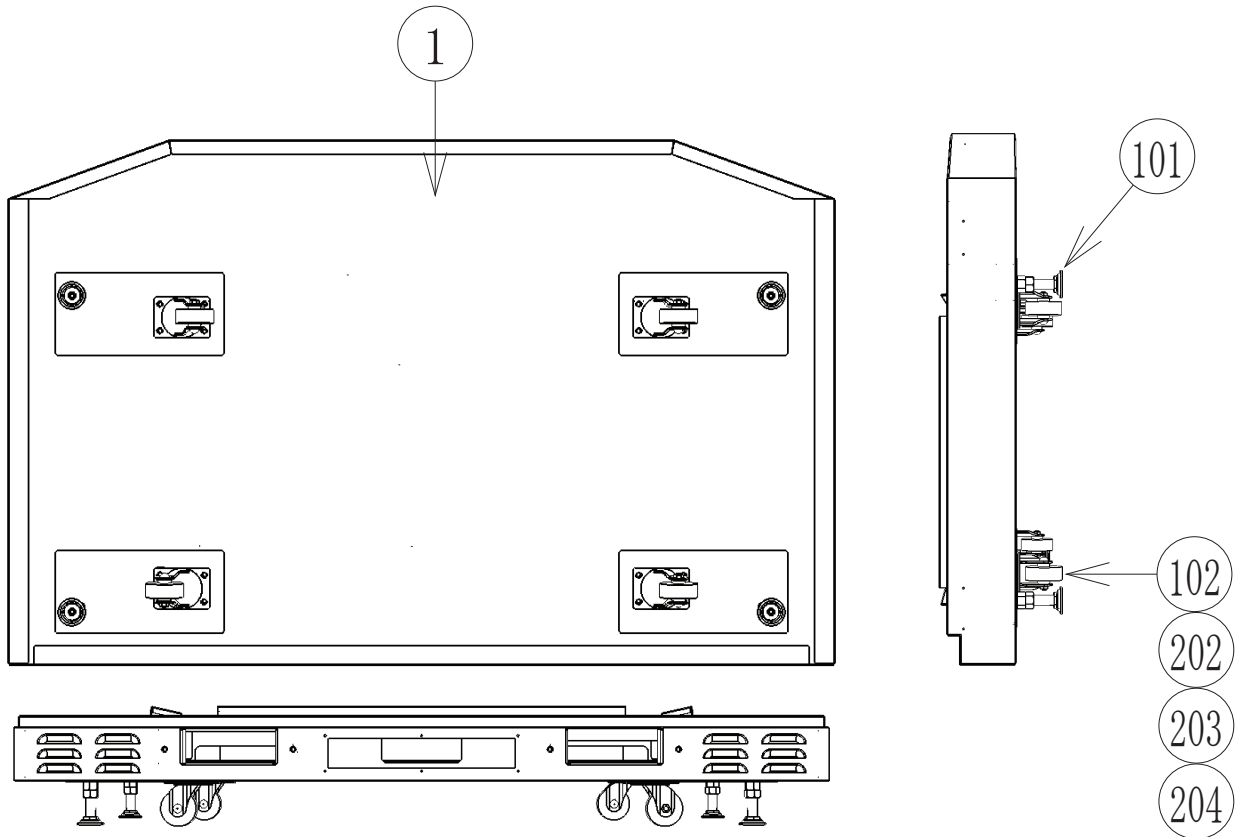

ITEM NO	PART NO	DESCRIPTION	QTY
****1	DV-3102UK	REAR BASE BLANK	1
****101	601-5699UK-01	LEG ADJ M16X100 1L/NUT	4
****102	MA1007	CASTOR SWIVEL 63mm NYLON	4
****201			4
****202	030-000816	M8X16 BLT PAS	16
****203	060-S00800	M8 WSHR SPR PAS	16
****204	060-F00800	M8 WSHR FORM A FLT PAS	16
***201	020-000616-OZ	M6X16 SKT CAP OZ	3
***202	060-S00600	M6 WSHR SPR PAS	3
***203	060-F00600	M6 WSHR FORM A FLT PAS	3
***204	020-000512-OZ	M5X10 SKT CAP OZ	2

13 ASSY BENCH WOOD (DV-3500UK)

(D-1/1)

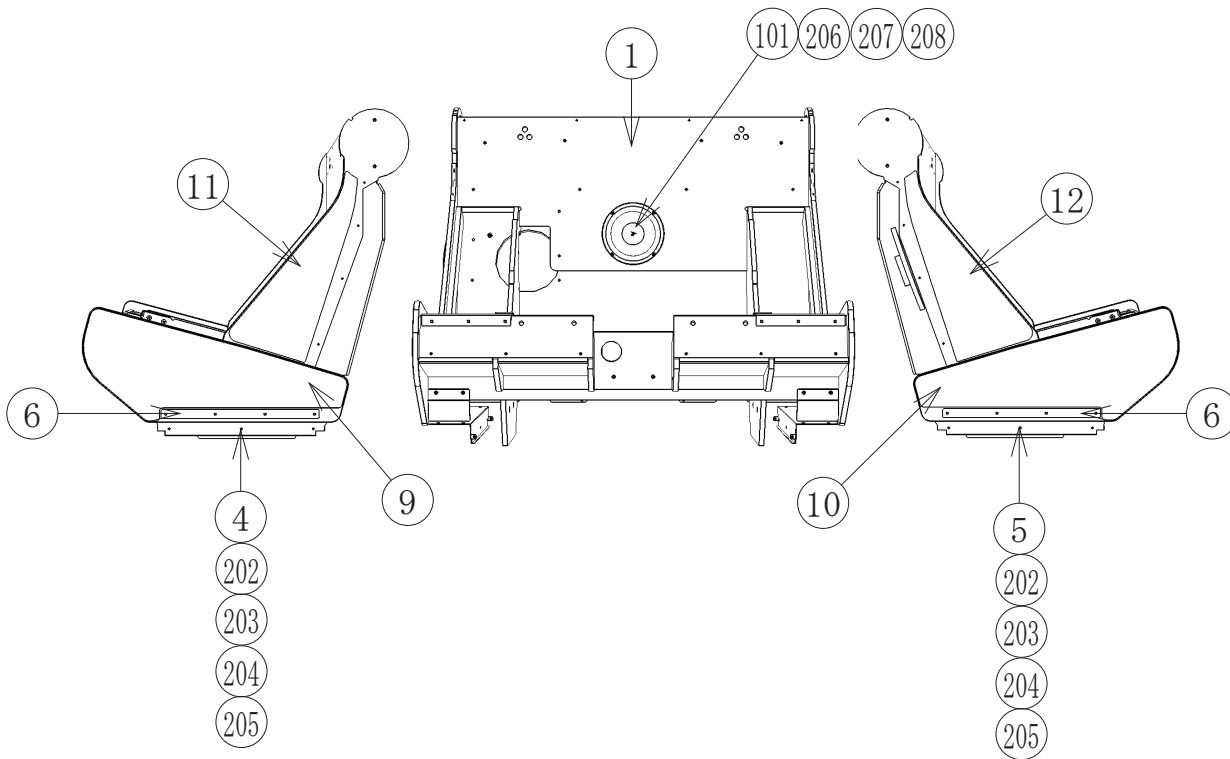

ITEM NO	PART NO	DESCRIPTION	QTY
***1	DV-3502UK	BENCH WOOD	1
***4	DV-3520UK	BELLOW UPPER BASE L	1
***5	DV-3521UK	BELLOW UPPER BASE R	1
***6	DV-3522UK	REAR CRG PLATE	2
***9	DV-3510UK	STICKER REAR SIDE L	1
***10	DV-3511UK	STICKER REAR SIDE R	1
***11	DV-3512UK	STICKER REAR SIDE UPPER L	1
***12	DV-3513UK	STICKER REAR SIDE UPPER R	1
***101	130-5280	WOOFER 40HM 80W SILVER RNE	1
***202	031-000630-0B	M6X30 CRG BLT BLK	10
***203	050-F00600	M6 NUT FLG SER PAS	8
***204	060-S00600	M6 WSHR SPR PAS	8
***205	068-652016	M6 WSHR 20OD FLT PAS	8
***206	000-P00425	M4X25 MSCR PAN PAS	4
***207	060-S00400	M4 WSHR SPR PAS	4
***208	068-441616-0B	M4 WSHR 16OD FLT BLK	4

14 ASSY BENCH WOOD SUB (DV-3502UK)

(D-1/1)

18

PARTS LIST

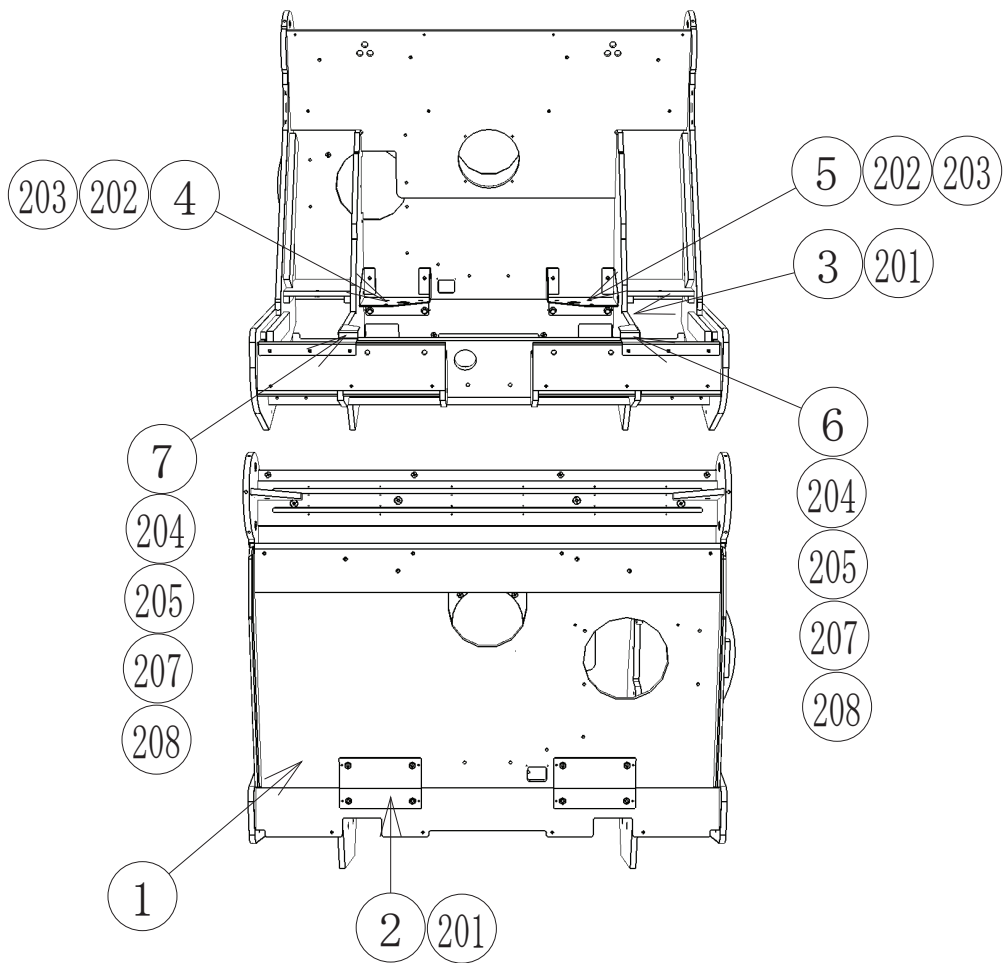

ITEM NO	PART NO	DESCRIPTION	QTY
****1	DV-3502-AUK	BENCH WOOD BLANK	1
****2	DV-3503UK	REAR NUT PLATE A	2
****3	DV-3504UK	REAR NUT PLATE B	2
****4	DV-3505UK	SEAT RACK BRKT REAR L	1
****5	DV-3506UK	SEAT RACK BRKT REAR R	1
****6	DV-3507UK	SEAT RACK BRKT FRONT L	1
****7	DV-3508UK	SEAT RACK BRKT FRONT R	1
****8	LGI-3509UK	REAR NUT BRKT	2
****201	012-P03512-F	N6X1/2" S/TAP FLG PAS	8
****202	030-000830	M8X30 BLT PAS	16
****203	060-S00800	M8 WSHR SPR PAS	16
****204	031-000625-0B	M6X25 CRG BLT BLK	6
****205	050-F00600	M6 NUT FLG SER PAS	6
****206	060-S00600	M6 WSHR SPR PAS	4
****207	068-652016	M6 WSHR 200D FLT PAS	10
****208	030-000620	M6X20 BLT PAS	4
****209	030-000825	M8X25 BLT PAS	4

15 ASSY SEAT BOTTOM (DV-3600UK)

(D-1/1)

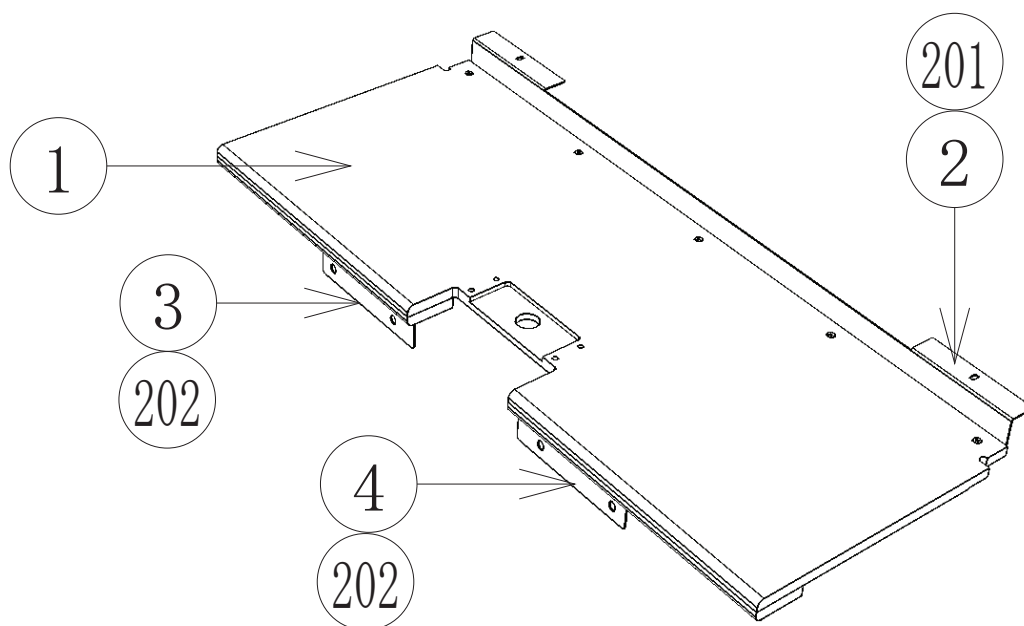

ITEM NO	PART NO	DESCRIPTION	QTY
***1	DV-3601-AUK	SEAT WOOD	1
***2	DV-3602UK	SEAT HOOK BRKT	1
***3	DV-3603UK	SEAT FIX BRKT L	1
***4	DV-3604UK	SEAT FIX BRKT R	1
***201	020-F00625-OZ	M6X25 SKT CSK OZ	5
***202	000-F00520	M5X20 MSCR CSK PAS	6

①⑥ ASSY SEAT BACK (DV-3650UK)

(D-1/1)

18

PARTS LIST

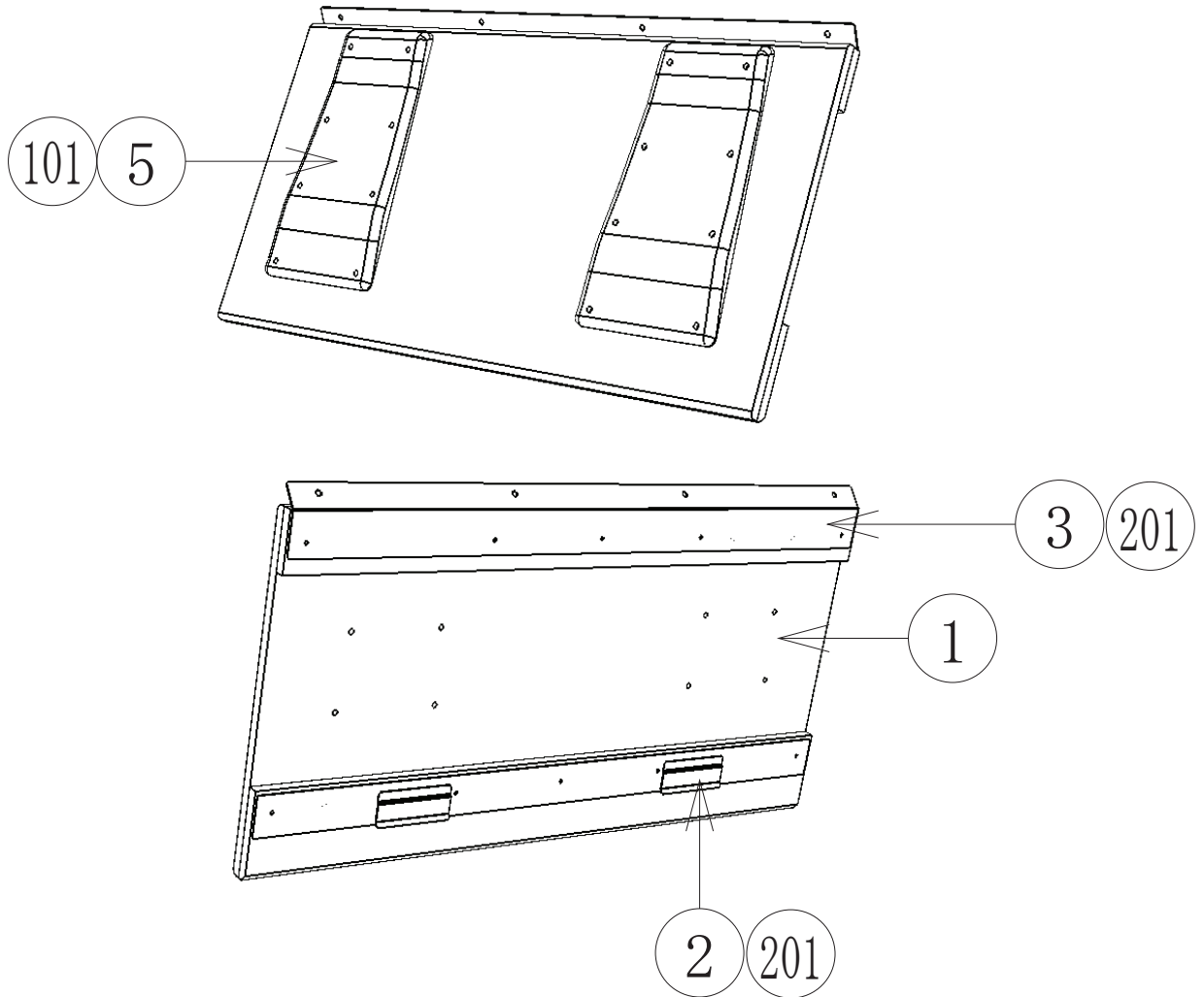

ITEM NO	PART NO	DESCRIPTION	QTY
***1	DV-3651-AUK	SEAT WOOD BACK	1
***2	DV-3652UK	SEAT BACK HOOK BRKT	1
***3	DV-3653UK	SEAT BACK FIX BRKT	1
***5	SPG-2401-BUK	UPPER SEAT INSERT	2
***101	280-K02529-WX	DRIVE FASTENER 25FH 24L 7.9DIA	16
***201	000-F00520	M5X20 MSCR CSK PAS	10

17 ASSY REAR VAC (DV-3700UK)

(D-1/1)

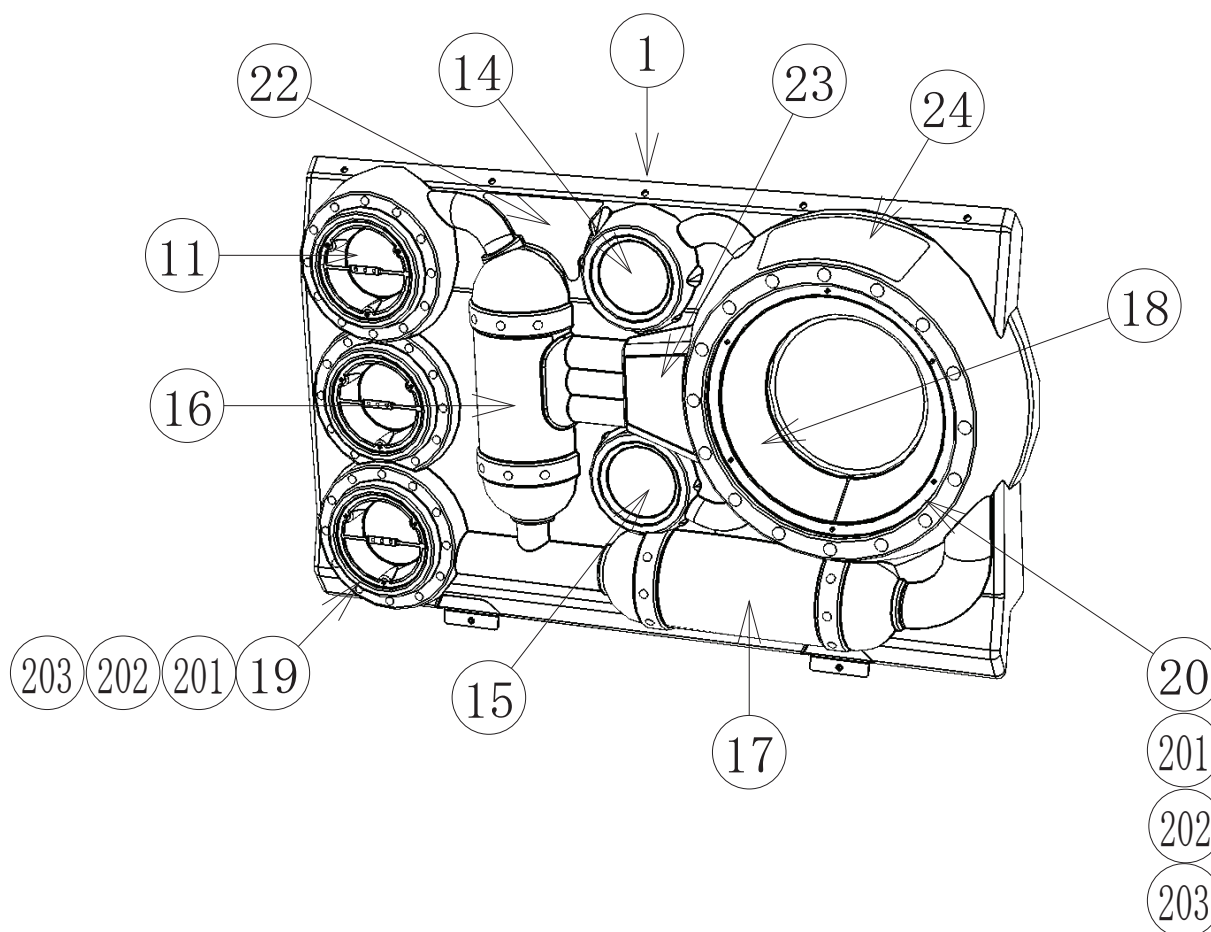

ITEM NO	PART NO	DESCRIPTION	QTY
***1	DV-3701UK	REAR VAC	1
***11	DV-3711UK	STICKER LIT L INNER	3
***14	DV-3714UK	STICKER MID UPPER	1
***15	DV-3715UK	STICKER MID LOWER	1
***16	DV-3716UK	STICKER TUBE VERT	1
***17	DV-3717UK	STICKER TUBE HORIZ	1
***18	DV-3718UK	STICKER MIRROR PLASMA	2
***19	DV-3719UK	PLATE LIT L OUTER	3
***20	DV-3720UK	PLATE PLASMA	1
***22	DV-3722UK	STICKER FACE TOP	1
***23	DV-3723UK	STICKER MANIFOLD CENTRE	1
***24	DV-3724UK	STICKER WARNING SEAT MOVE	1
***101	OS1247	ALUMINIUM STICKY CLIP ASK-3	3
***201	029-B00416-0B	M4X16 SKT BH BLK	15
***202	050-F00400	M4 NUT FLG SER PAS	15
***203	068-441616-0B	M4 WSHR 16OD FLT BLK	15
***301	DV-6002UK	ASSY LED RGB RIGID 50MM	3

⑱ ASSY SWITCH UNIT (DV-3850UK)

(D-1/1)

18

PARTS LIST

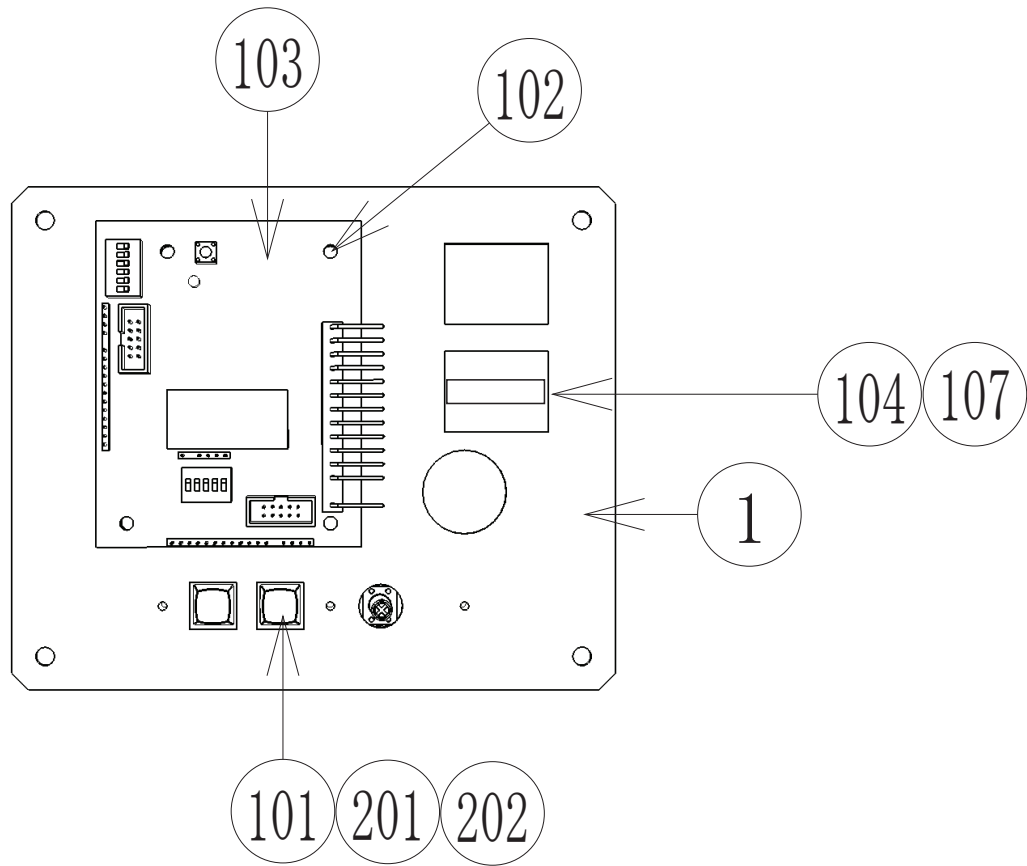

ITEM NO	PART NO	DESCRIPTION	QTY
****1	SSR-0321UK	SW BRKT DOUBLE METER	1
****101	838-14548-01AUK	SW & VOL CTL BD	1
****102	280-L00706-PM	STANDOFF 6.4MM HOLE PM	4
****103	EP1380-01	CREDIT BOARD EXCEL	1
****104	220-5643UK	COIN METER SMALL 12V	1
****105	OS1247	ALUMINIUM STICKY CLIP ASK-3	1
****107	OS1098	CRIMP BELL END SMALL	4
****108	601-0460	CABLE TIE NYLON 100MM	2
****201	000-P00308	M3X8 MSCR PAN PAS	3
****202	068-330808-PN	M3 WSHR 8OD FLT NYLON	3



19 ASSY DUAL COIN CRADLE (DV-3865UK)

(D-1/1)

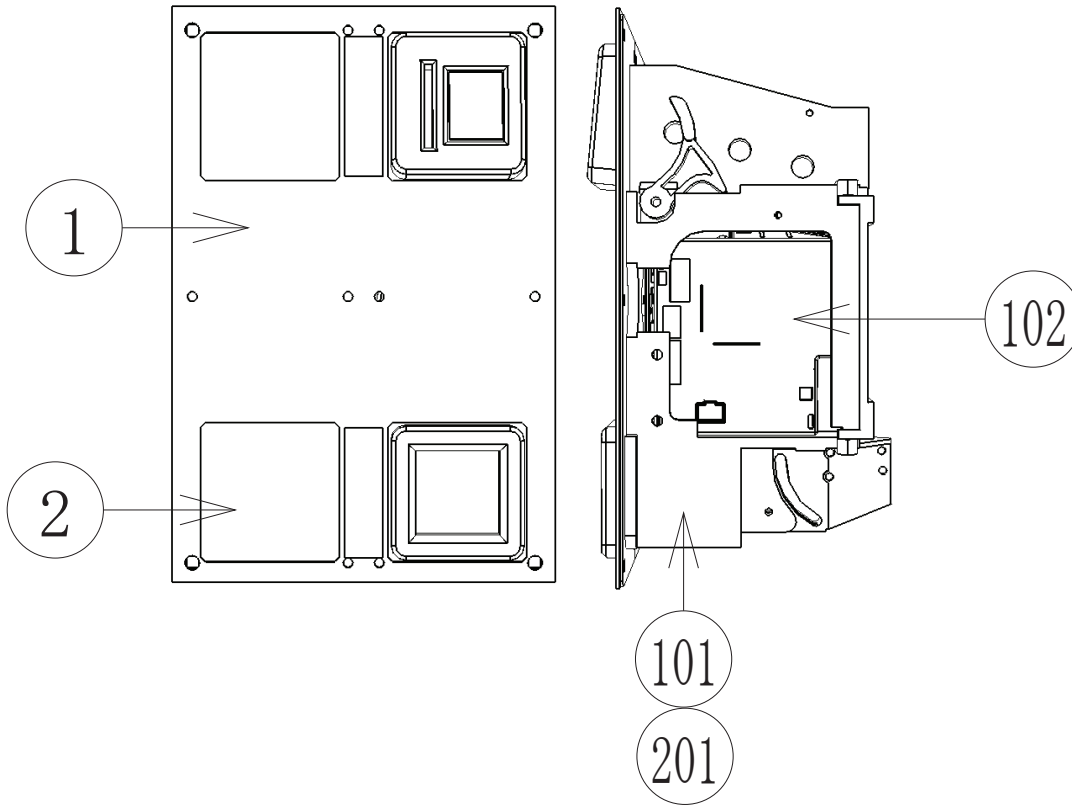

ITEM NO	PART NO	DESCRIPTION	QTY
****1	DV-3866UK	PLATE COIN ENTRY DUAL	1
****2	DV-3867UK	PLATE BLANKING FRONT PLATE	1
****101	220-5786-R	A0710 IL FRONT PLATE ROHS COMPLIANT	1
****102	220-5620-25C	MECH MECHANICAL 25 CENT	1
****201	050-U00400	M4 NUT NYLOK PAS	6
****107	OS1098	CRIMP BELL END SMALL	4
****108	601-0460	CABLE TIE NYLON 100MM	2
****201	000-P00308	M3X8 MSCR PAN PAS	3
****202	068-330808-PN	M3 WSHR 8OD FLT NYLON	3

② ASSY CONTROL TOWER 2 (DV-3900UK)

(D-1/1)

18

PARTS LIST

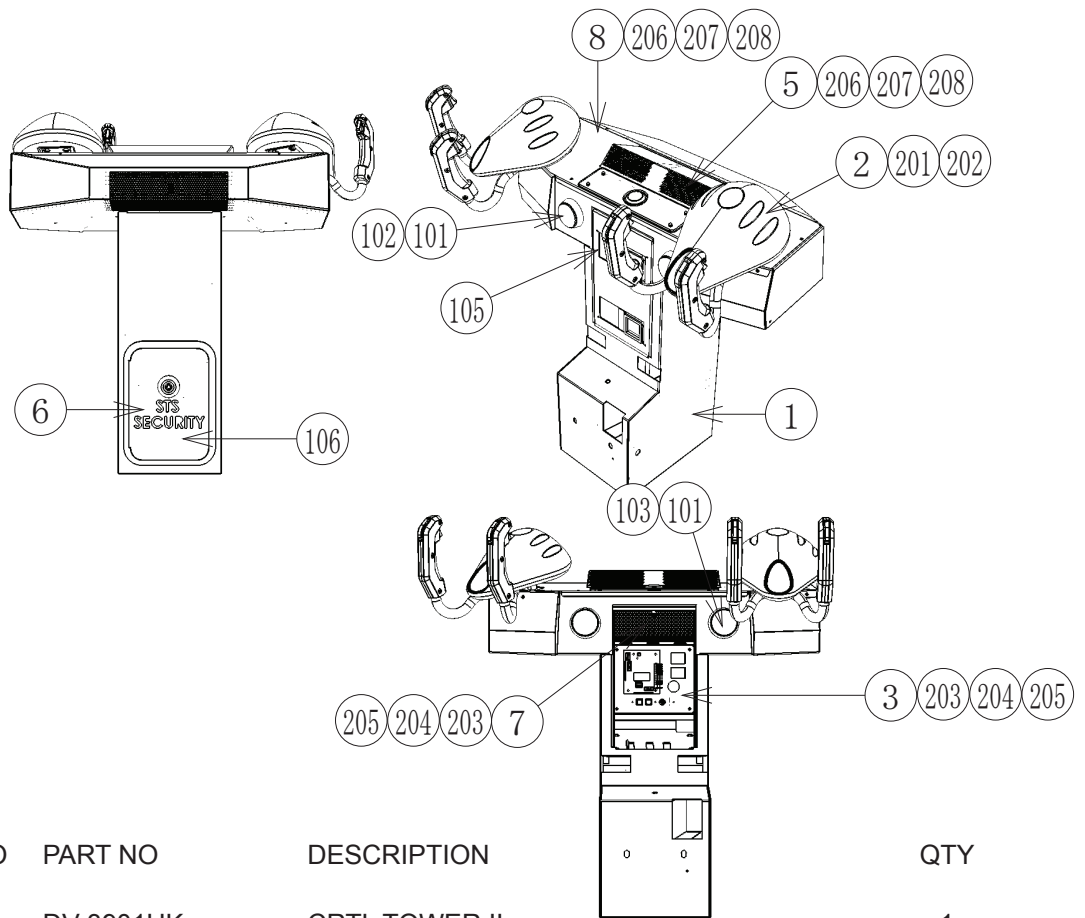

ITEM NO	PART NO	DESCRIPTION	QTY
***1	DV-3901UK	CRTL TOWER II	1
***2	DV-2000UK	ASSY CONTROLLER	2
***3	DV-3850UK	ASSY SW UNIT	1
***4			1
***5	DV-3970UK	ASSY CTRL PNL II	1
***6	PP1087	BOX CASH FOR MINI DOOR	1
***7	DV-3980UK	ASSY BLOWER CTRL PNL	1
***8	DV-3903UK	PLATE CONT COVER	2
***101	509-6131UK	BUTTON 12V 1.2W S'POINT CPB	2
***102	509-6131-EUK	LEGEND DV 1P S'POINT CPB	1
***103	509-6131-FUK	LEGEND DV 2P S'POINT CPB	1
***104	OS1247	ALUMINIUM STICKY CLIP ASK-3	3
***105	220-5575UK	LOCK (J9117) KEY TO LIKE 22MM W CAM	1
***106	220-5727-01B	DOOR CASH H.S. STS	1
***201	030-000820-W	M8X20 BLT W/S PAS	8
***202	060-F00800	M8 WSHR FORM A FLT PAS	8
***203	000-P00412	M4X12 MSCR PAN PAS	6
***204	060-S00400	M4 WSHR SPR PAS	6
***205	060-F00400	M4 WSHR FORM A FLT PAS	6
***206	029-B00416-0B	M4X16 SKT BH BLK	10
***207	060-S00400-0B	M4 WSHR SPR BLK	10
***208	068-441616-0B	M4 WSHR 16OD FLT BLK	10
***301	DV-60012UK	WH COIN TOWER EXTN	1
***301	DV-60015UK	WH BUTTONS	1
***301	DV-60016UK	WH COIN HANDLING	1

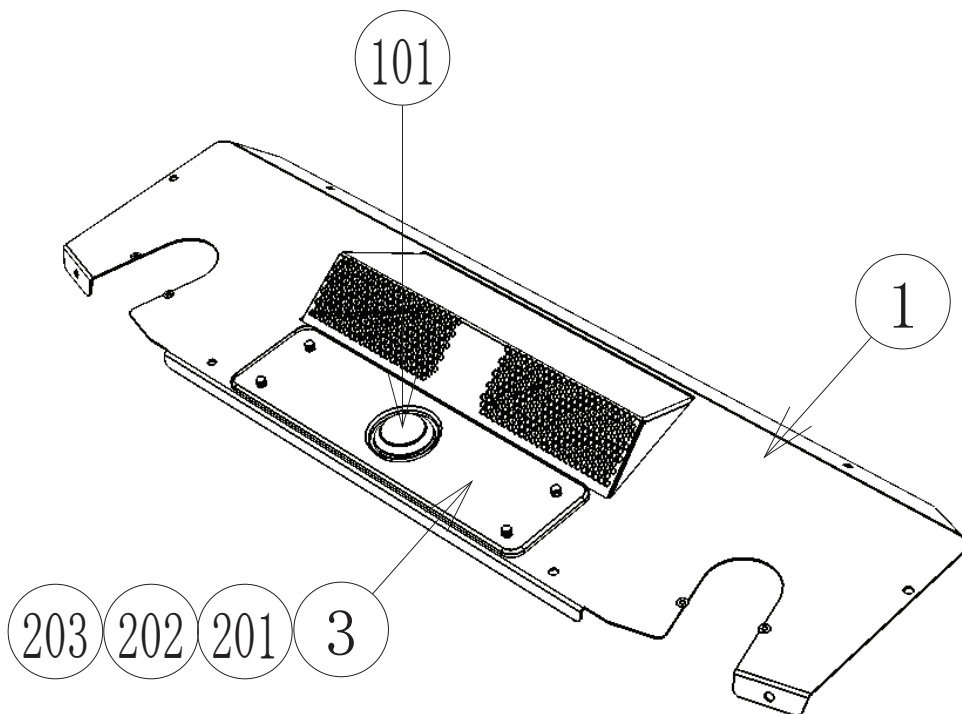

ITEM NO	PART NO	DESCRIPTION	QTY
****1	DV-3971UK	BASE CTRL PNL II	1
****3	DV-3973UK	PLATE MOTION STOP SURROUND	1
****101	509-6002-R	BTN RND 44MM 12V RED 22-2070-2	1
****201	029-B00416-0B	M4X16 SKT BH BLK	4
****202	060-S00400	M4 WSHR SPR PAS	4
****203	068-441616-0B	M4 WSHR 16OD FLT BLK	4

22 ASSY BLOWER CTRL PAN (DV-3980UK)

(D-1/1)

18

PARTS LIST

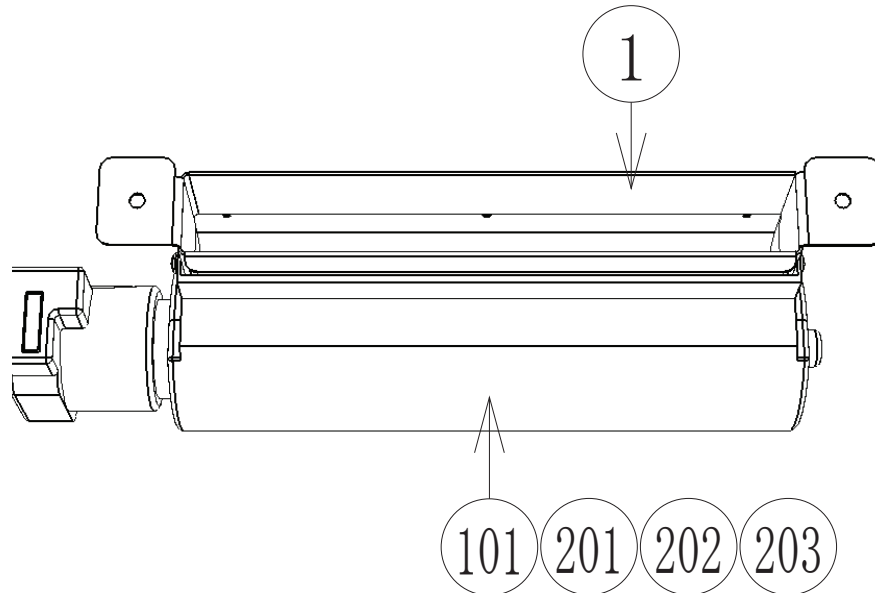

ITEM NO	PART NO	DESCRIPTION	QTY
***1	DV-3981UK	BRKT BLOWER MOUNT	1
***101	260-0024-03UK	FAN TANGENTIAL 55668 34010	1
***201	000-P00408	M4X8 MSCR PAN PAS	2
***202	060-S00400	M4 WSHR SPR PAS	2
***203	060-F00400	M4 WSHR FORM A FLT PAS	2
***301	DV-60017UK	WH BLOWERS	1

23 ASSY FAN (RD-1340UK)

(D-1/1)

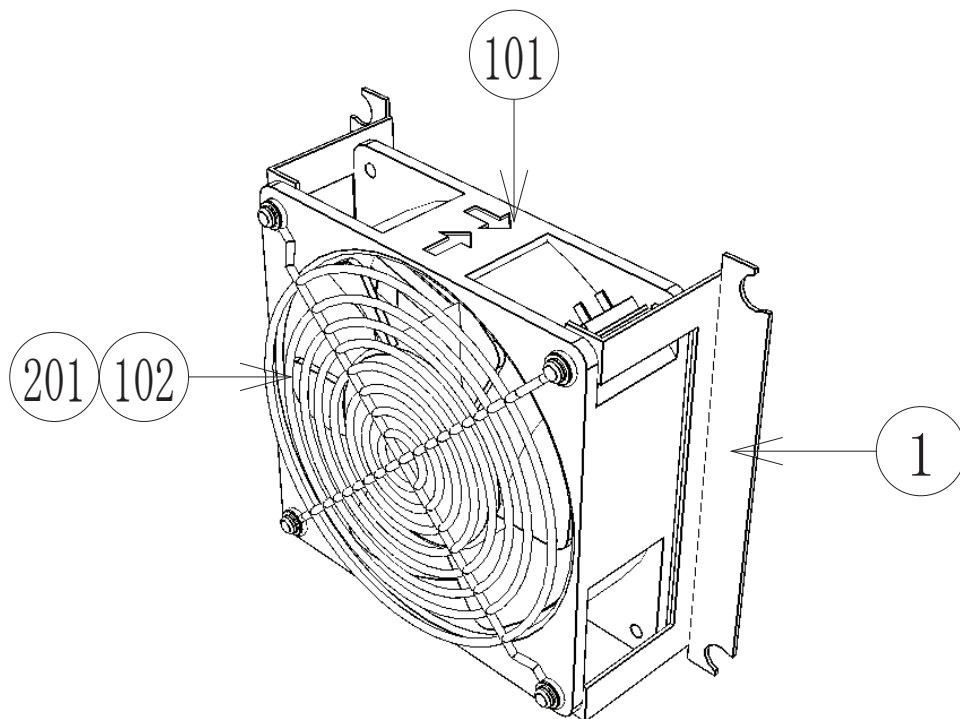

ITEM NO	PART NO	DESCRIPTION	QTY
***1	105-5340-01	FAN BRKT LONG	2
***101	260-0011-02	FAN AC100V 50-60HZ (SP100A-1123 X 5T)	1
***102	FN1012	FAN GUARD METAL 120MM (FG-12)	1
***201	000-P00312-W	M3X12 MSCR PAN W/FS PAS	4
***301	ST-60026UK	WH 240V FAN	1

## 19 WIRE COLOUR CODE TABLE

### WARNING

The DC power wire color for this product is different from previous SEGA titles. Working from the previous wire colors will create a high risk of fire.

The color codes for the wires used in the diagrams in the following chapter are as follows.

A	PINK
B	SKY BLUE
C	BROWN
D	PURPLE
E	LIGHT GREEN

Wires other than those of any of the above 5 single colors will be displayed by 2 alphanumeric characters.

1	RED
2	BLUE
3	YELLOW
4	GREEN
5	WHITE
7	ORANGE
8	BLACK
9	GRAY

If the right-hand side numeral of the code is 0, then the wire will be of a single color shown by the left-hand side numeral (see the above).

Note 1: If the right-hand side numeral is not 0, that particular wire has a spiral color code. The left-hand side character shows the base color and the right-hand side one, the spiral color.

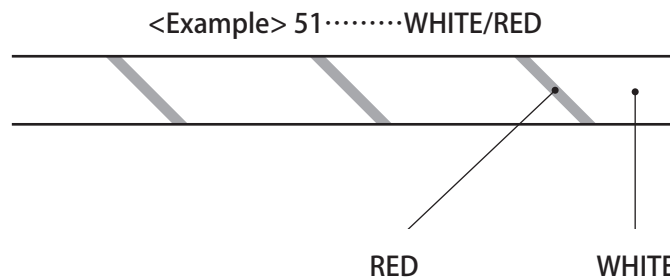

Note 2: The character following the wire color code indicates the size of the wire.

U :	AWG16
K :	AWG18
L :	AWG20
None :	AWG22

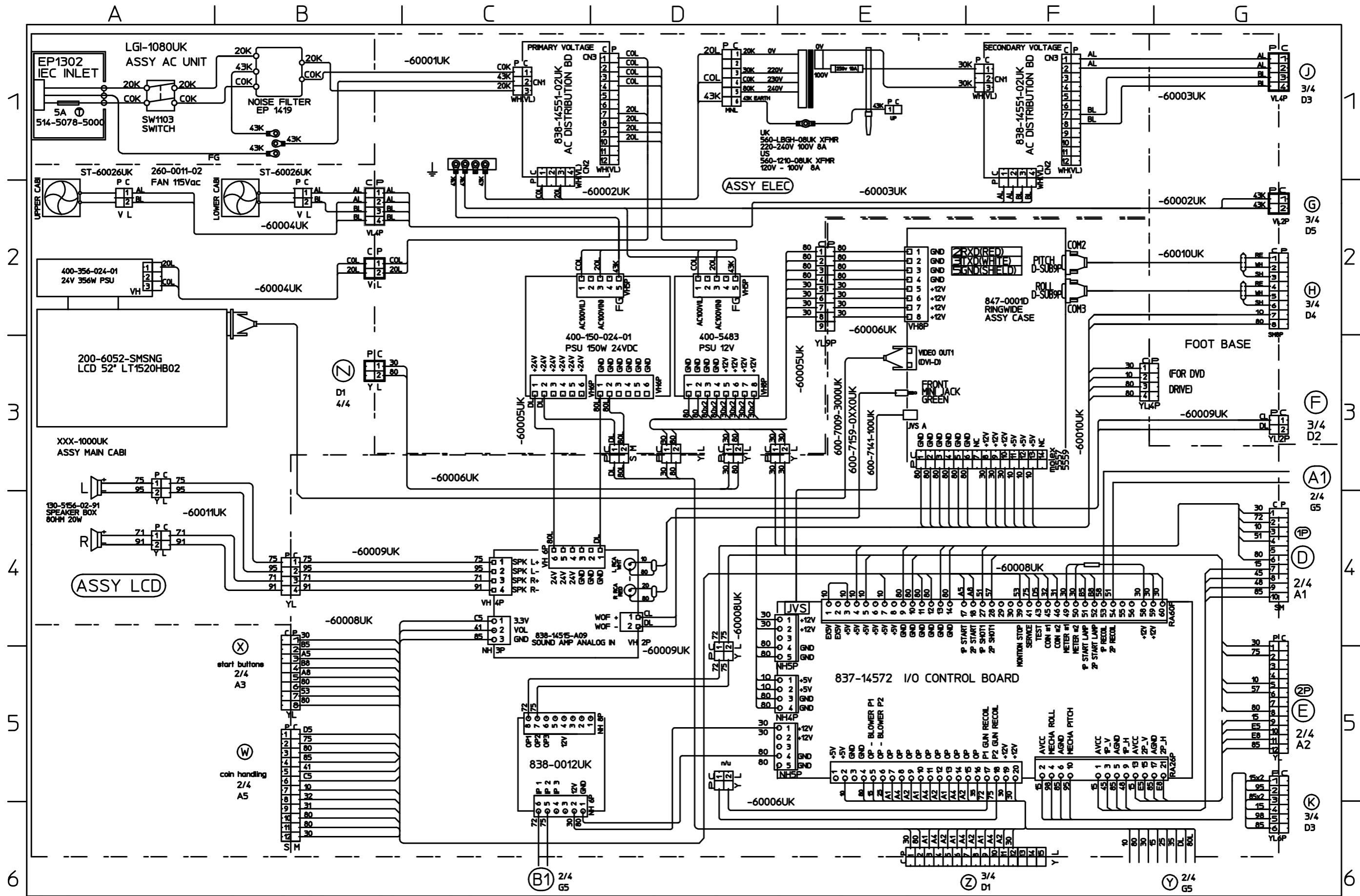

8	BLACK	E	LIGHT GREEN	43	EARTH WIRE
7	ORANGE	D	PURPLE	*	AWG18 UL1672
6	WHITE	C	BROWN	†	AWG20 UL1672
5	GREEN	B	SKY BLUE	‡	AWG16 UL1015
4	YELLOW	A	PINK	§	AWG18 UL1015
3	BLUE	9	GRAY		AWG20 UL1672
2	BLUE				AWG22 UL1007
1	RED				AWG24 UL1007

DV-0000UK  
TOP-ASSY  
12/3/12

RA

SEGA AMUSEMENTS EUROPE LTD  
THIS DRAWING WILL IN NO WAY BE COPIED.  
TO BE RETURNED ON DEMAND.

(1/4)  
DIAGRAM No.

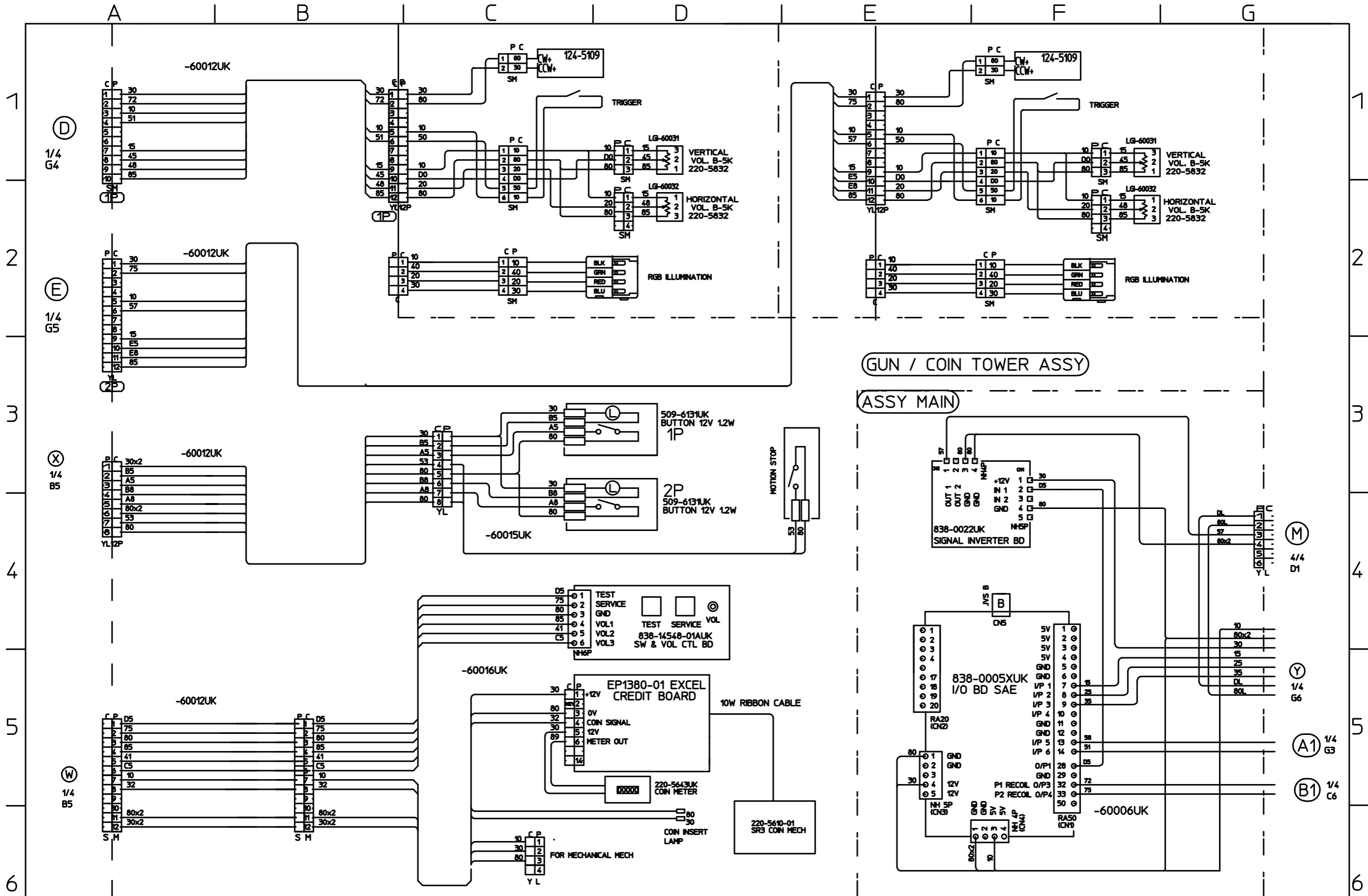

ALTERATION		8 BLACK 7 ORANGE 6 WHITE 5 GREEN 4 YELLOW 3 BLUE 2 BLUE 1 RED		E LIGHT GREEN D PURPLE C BROWN B SKY BLUE A PINK 9 GRAY		43 EARTH WIRE * AWG18 UL1672 † AWG20 UL1672 ‡ AWG16 UL1015 † AWG18 UL1015 ‡ AWG20 UL1007 † AWG22 UL1007		DV-0000UK TOP-ASS'Y 12/3/12		RA		SEGA AMUSEMENTS EUROPE LTD THIS DRAWING WILL IN NO WAY BE COPIED. TO BE RETURNED ON DEMAND.		( 2 / 4 ) DIAGRAM No.	
------------	--	--	--	--	--	---	--	-----------------------------------	--	----	--	---	--	--------------------------	--



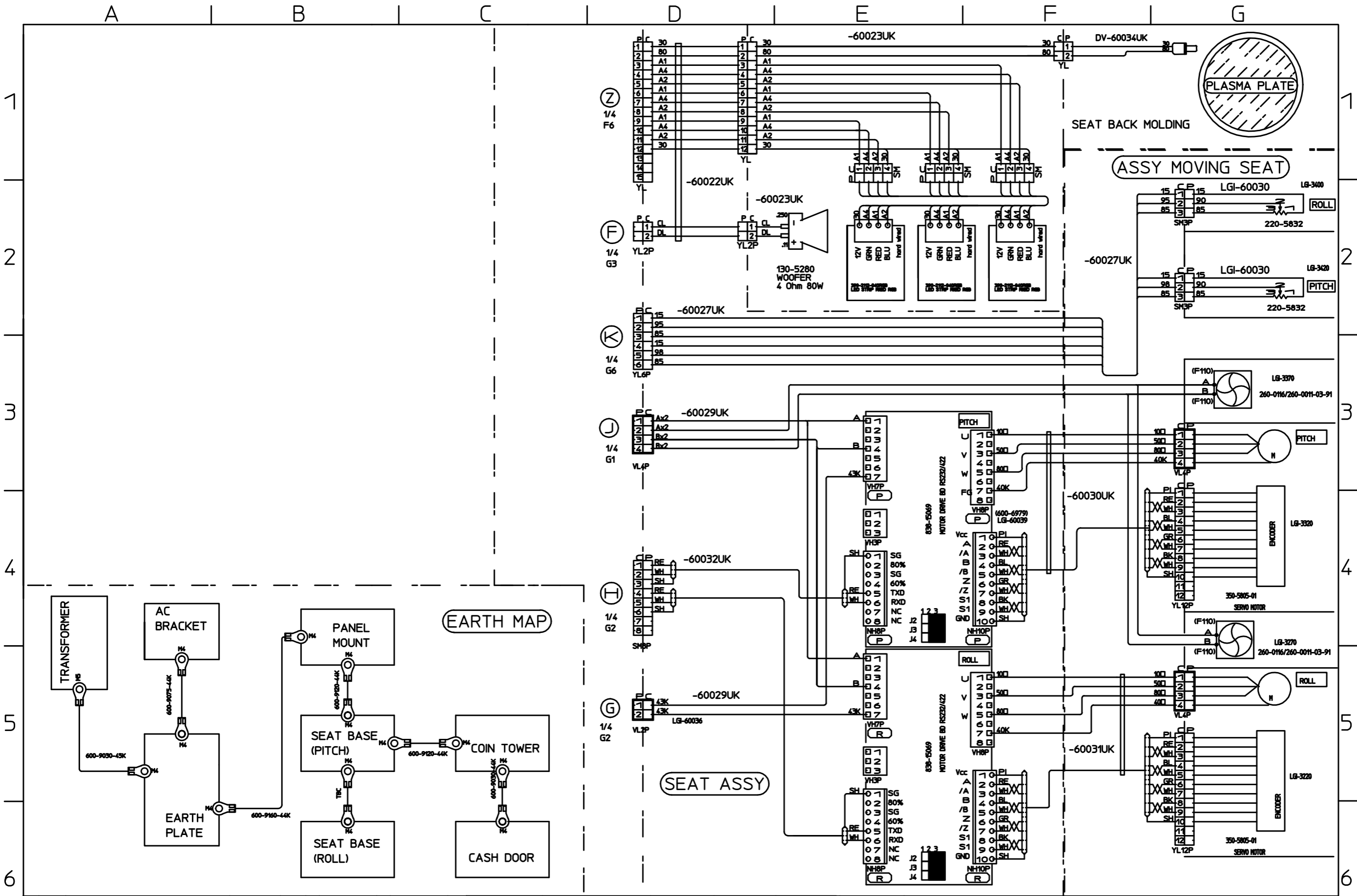

8	BLACK	E	LIGHT GREEN	4-3	EARTH WIRE
7	ORANGE	D	PURPLE	H	AWG18 UL1677
6	WHITE	C	BROWN	H	AWG20 UL1677
5	GREEN	B	SKY BLUE	K	AWG16 UL1015
4	YELLOW	A	PINK	L	AWG18 UL1015
3	BLUE			M	AWG22 UL1007
2	RED			T	AWG24 UL1007

DV-0000UK	RA			
TOP-ASS'Y	12/3/12			

SEGA AMUSEMENTS EUROPE LTD	THIS DRAWING WILL IN NO WAY BE COPIED. TO BE RETURNED ON DEMAND.
(3 / 4)	DIAGRAM No.

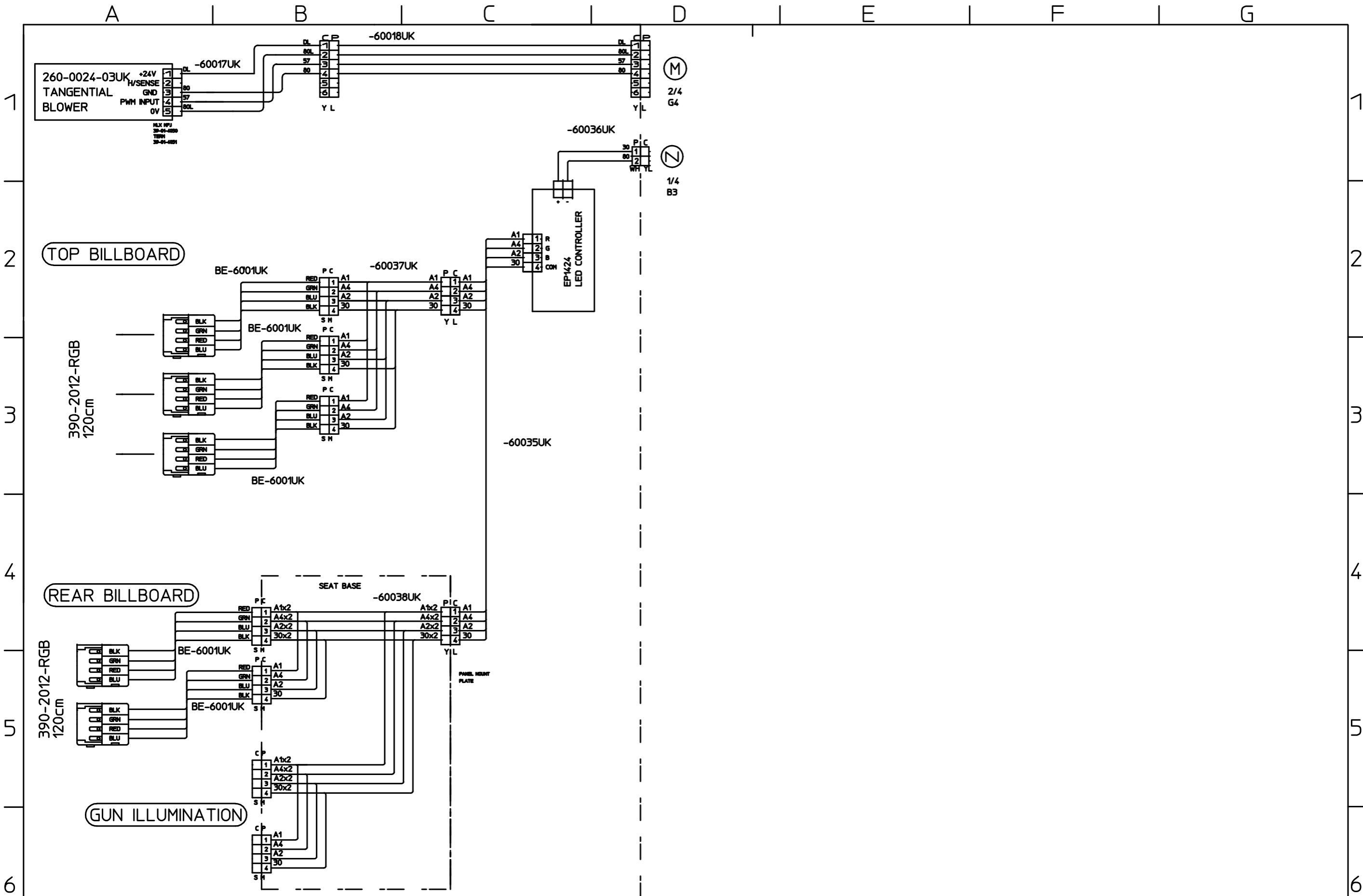

8	BLACK	4	EARTH WIRE
7	ORANGE	3	ELIGHT GREEN
6	WHITE	2	PURPLE
5	GREEN	1	BROWN
4	YELLOW	0	SKY BLUE
3	BLUE		PINK
2	RED		GRAY

DV-0000UK	RA				
12/3/12					

SEGA AMUSEMENTS EUROPE LTD	THIS DRAWING WILL IN NO WAY BE COPIED. TO BE RETURNED ON DEMAND.
( 4 / 4 )	
DESCRIPTION	DIAGRAM No.