



For parts or service, contact your local distributor, or:

Betson Enterprises

303 Paterson Plank Road

Carlstadt, New Jersey 07072-2307



Main Phone: (201) 438-1300

Toll Free Phone: (800) 524-2343

Part Phone: (800) 828-2048

Chapter 1. Safety

Safety instructions apply to operators and service personnel. Read these instructions before preparing the video game machine for play. Other safety instructions appear throughout this manual.

♦ **WARNING: TRANSPORTING THE VIDEO GAME MACHINE.** The VIDEO GAME MACHINE contains glass and fragile electronic devices. During transport, use appropriate care. Avoid rough handling.

♦ **WARNING: DISCONNECT POWER.** Before servicing, moving or adjusting the VIDEO GAME MACHINE, turn off the VIDEO GAME MACHINE and unplug the AC line cord. Lethal voltages still exist in the game when power is disconnected. Use extreme caution while servicing. Servicing the game while powered can damage components and voids your warranty.

♦ **WARNING: AC GROUNDING.** Avoid electrical shock! Do not plug in the VIDEO GAME MACHINE until you have verified a properly grounded AC outlet is available for use. Only use a grounded, three-wire outlet. Do not use an adapter that removes the ground connection. Do not cut off the ground pin of the line cord.

♦ **WARNING: AVOID ELECTRICAL SHOCKS.** This VIDEO GAME MACHINE does not use an isolation transformer. Disconnect power before servicing. Lethal voltages still exist in the game while power is disconnected. Use extreme caution while servicing. Verify the game has a working ground connection. Do not use VIDEO GAME MACHINE and disconnect power if the unit has water damage.

♦ **WARNING: HANDLE FLOURESCENT TUBE AND LCD WITH CARE.** If you drop a fluorescent tube or hit the corner of tempered glass LCD enclosure it will break! Shattered glass can travel extreme distances and cause bodily harm. Proper procedures must be used when handling broken materials. These items can contain hazardous materials such as mercury or lead.

♦ **WARNING: CHECK POWER SELECTOR, LAMP.** Before installing the VIDEO GAME MACHINE, verify that the VIDEO GAME MACHINE is properly set for the AC line voltage of the installation site. On the computer, notice the 115/230 VAC selector switch. Set this switch for the correct line voltage at the installation site. Verify the fluorescent lamp rating. The rating must match the line voltage at the installation site.

♦ **WARNING: USE PROPER FUSE.** Avoid electrical shock! Disconnect power to the VGM before servicing. Fuse replacement by qualified service technician only. For continued protection replace a fuse with identical rated fuse.

♦ **WARNING: ATTACH CONNECTORS PROPERLY.** Be sure all connectors mate properly. If connectors do not slip in easily, do not force them. Keyed connectors only connect one way. Check for correct orientation.

♦ **WARNING: USE EXTREME CARE WHEN HANDLING COMPONENTS.** The device contains numerous components that are very sensitive to handling, environmental and ESD(Electro Static Discharges) events. The computer contains sensitive components. Do not handle the computer roughly. Before servicing call your distributor and inquire about the computer's warranty. Utilize proper ESD procedures when servicing the VIDEO GAME MACHINE or components of the VIDEO GAME MACHINE. Do not expose the VIDEO GAME MACHINE or any components of the VIDEO GAME MACHINE to adverse environmental conditions, including but not limited to extreme temperatures or excessive moisture.

♦ **WARNING: HAZARD TO EPILEPTICS.** A small portion of the population has an epileptic condition that may cause seizures. Affected persons experience seizures while watching some television pictures or playing certain video games. People who have not had seizures may still have an undetected epileptic condition.

If anyone in your family has experienced epilepsy symptoms (seizures or loss of awareness), consult your physician before using video games.

While children play video games, a parent should observe. Be alert to the following symptoms: Dizziness, altered vision, eye or muscle twitching, involuntary movements, loss of awareness, disorientation, or convulsions. If you or your child experiences these symptoms, *discontinue use immediately* and consult your physician.

WARNING: POWER CORD REPLACEMENT. If the power cord is damaged or missing it must be replaced by an identical line cord as supplied by the manufacturer or authorized service agent.

WARNING: WATER JET. Do not install or operate game within operating perimeter of a water jet. Do not clean VIDEO GAME MACHINE using water jet.

Ⓢ **WARNING: Access to the back of the game should be limited to service personnel only.** Allow space between wall or another game for sufficient ventilation while preventing unauthorized access to the back of the game. Keep vent holes free of objects that could restrict airflow.

Ⓢ **CAUTION**

- Failure to properly operate this machine could result in malfunction or accident. Before operating your video game device, read this manual. Operate the machine according to instructions in this manual.
- Keep this manual available and ready for use.
- If the machine fails to function properly, immediately turn off the machine and unplug the AC line cord. Contact your local distributor. (Your warranty lasts 60 days from your purchase date.)

Ⓢ **CAUTION**

- For reasons such as performance, this product's specifications might change without notice.
- Federal patent, copyright and other intellectual property laws protect the content, devices and design of the VIDEO GAME MACHINE.
- Without authorization, you may not reproduce this document or any of its contents.

LEGAL NOTICE



Guitar Hero Arcade © 2007-2008 Activision Publishing, Inc. Guitar Hero, Activision and RedOctane are registered trademarks of Activision Publishing, Inc. Covered by one or more of the following patents: U.S. Patent Nos. 5,739,457, 6,018,121, 6,225,547, 6,268,557, 6,347,998, 6,369,313, 6,390,923, 6,425,822, 6,554,711, 6,645,067, 6,607,446, 6,609,979, 6,612,931, 6,638,160, 6,769,689, 6,821,203, 6,835,887, 6,915,488 and 6,225,547; patents pending. Certain technology and cabinet design © 2008 Konami Digital Entertainment. Distributed by Konami Digital Entertainment, Inc. under license from Activision Publishing, Inc. KONAMI is a registered trademark of KONAMI CORPORATION. All other trademarks and trade names are the properties of their respective owners. All rights reserved.

Chapter 2. Setup & Operation

Product Specifications

ELECTRICAL POWER

Domestic	120 VAC @ 60 Hz, 5 amps
International Users	230 VAC @ 50 Hz, 2.5 amps
Japan	100 VAC @ 50 Hz, 5 amps

DC POWER FUSE GUIDE

+5 VDC	3 AMP Slow Blow
+12 VDC	7 AMP Slow Blow

TEMPERATURE

32° F to 100° F
(0° C to 38° C)

HUMIDITY

Must not exceed 95% relative humidity.

CABINET DIMENSIONS

Height = 86 in. (218.4 cm)
Depth = 39.5 in. (100.3 cm)
Width = 32.5 in. (82.6 cm)

CABINET WEIGHT

Weight (Shipping) = 472 lbs. (214 kg)



Inspection & Installation

♦ **WARNING.** Use extreme care when moving or servicing the game cabinet. Moving or servicing the game by to be performed by qualified service personnel only. Read this manual before you connect power to the VIDEO GAME MACHINE.

- [] 1. Make sure the shipping crate is on a flat stable surface.
- [] 2. Using an appropriate tool, cut the banding straps.
- [] 3. Remove the cardboard lid from atop of the shipping crate. Do not cut the packaging with knife or sharp objects to prevent damaging the game or its artwork.
- [] 4. Lift off the large cardboard container that surrounds the VIDEO GAME MACHINE. Do not use a sharp tool to cut the cardboard container the VIDEO GAME MACHINE is enclosed in.
- [] 5. Remove shipping cleats.
- [] 6. Remove VIDEO GAME MACHINE from the shipping pallet. Seek help as required by your situation.
- [] 7. Remove packing material from the guitars. Do not use knives or sharp objects that could scratch or damage the guitars.
- [] 8. Place the VIDEO GAME MACHINE in a suitable play or service area. Choose a well lit area for setup.
- [] 9. For safety reasons, make sure the game cabinet is level and stable. Adjust the leg levelers as necessary. Leveling the cabinet is a job for two or more people. Seek help as required by your situation.
- [] 10. Make sure that the AC service outlet is properly grounded and fused appropriately. Avoid overloading the AC service line for safety reasons. This may create a low voltage situation which could affect the game's reliability.
- [] 11. Check for shipping damage to the following:
 - Guitar assembly: Left and right guitars, guitar holders, and cable
 - Cabinet glass: Marquee and monitor
 - Cabinet back door
 - Cabinet coin door
 - Cabinet and guitar decals
- [] 12. Remove the coin door key from the coin return chute.
- [] 13. Open the top coin door. Locate the key for the back door and the cash box.
- [] 14. Open the cash box and remove the plastic bag containing 4 bolts needed to install the marquee. Remove the items inside the bag. The items enclosed will include this service manual, a restore DVD or CD and aa AC line cord. Please see page 2-10 for more detailed instructions on how to mount the marquee. **IMPORTANT SAFETY NOTICE:** Perform all the steps as described for securing the marquee before moving to Step 15 of the setup procedure.
- [] 15. Verify that a proper working AC outlet is available for use. Verify the AC outlet voltage. Verify the AC outlet ground connection is present and working.

- [] 16. Verify the VIDEO GAME MACHINE is setup for the correct AC voltage. This involves opening the VIDEO GAME MACHINE back door. Use extreme caution when inside the game. Utilize appropriate ESD and safety procedures. Verify that the computer voltage selector switch is properly set to match the AC outlet voltage. Verify the fluorescent fixture in the marquee (top front of the VIDEO GAME MACHINE) is the correct voltage. This will involve removing the marquee.
- [] 17. Once the VIDEO GAME MACHINE voltage has been set/verified and the AC outlet ground and voltage has been verified, plug the in VIDEO GAME MACHINE line cord into the AC outlet.
- [] 18. On the back of the game cabinet, locate the game AC power switch. The switch is on the bottom left side (you facing the back side of the VIDEO GAME MACHINE). Turn on the VIDEO GAME MACHINE.
- [] 19. Verify that the cooling fan located on the top right behind of the VIDEO GAME MACHINE is working. If not, turn off and disconnect AC line cord of the VIDEO GAME MACHINE. Check the 12V LED indicator on the JAMMA i/o board to see if the 12V power supply is functioning.
- [] 20. Verify that the VIDEO GAME MACHINE or any component of the VIDEO GAME MACHINE is not excessively hot or is emitting any foul odors. If so, turn off and disconnect the AC line cord of the VIDEO GAME MACHINE immediately. Refer to the diagnostic section of this manual for help.
- [] 21. While loading you should see information on the video display. If not, see the diagnostic section of this manual.
- [] 22. Once the VIDEO GAME MACHINE software is loaded, it may have the guitar mating screen posted. If the guitars needed to be mated, simply follow the instructions on the display. For more detailed information on mating the guitar, please refer to the "Guitar Mating" section under the Diagnostic menu.
- [] 23. If the game attract screen appears upon boot up, verify that the game is fully functional by performing test items listed in the "Diagnostic Menu" of the Test Menu. Please refer to Chapter 3: Diagnostics and Audits section of the manual for more details.
- [] 24. Test the guitar fret switches, strum bar switch and Star Power tilt.
- [] 25. Test the Start buttons and lamps.
- [] 26. Test the coin switches and Dollar Bill Acceptor if installed.
- [] 27. Verify the audio works and is not distorted. Adjust volume if needed.
- [] 28. Verify that the picture contrast, brightness and size is correct.
- [] 29. Play a test game in single player and two player mode. Perform final volume adjustments based on preference and location.

Marquee (Top Box) Installation

IMPORTANT NOTICE. This procedure must be performed by two individuals capable of lifting heavy items up height of 6 feet (1.8 meters). Make sure the video game machine is stabilized using the leg levelers and power cord is disconnected. The following tools are required: Phillips screw driver and 7/16" nut driver.

Step 1: Locate the plastic bag with the fastening hardware in the cash box. Verify that it has (4) each of the following: ¼ x 20 x 2 1/2 in. hex bolts, flat washers, split lock washers.

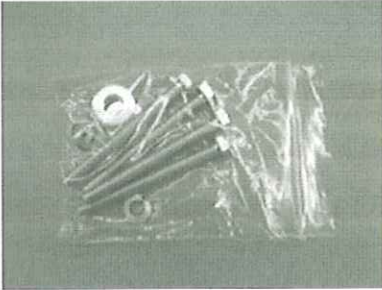

Step 2: Remove the marquee shipping bracket using a Phillips screw driver (4 Places). Do not discard screws and bracket - store for future use. Open the access LCD access door.

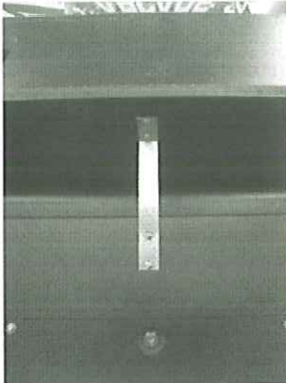

Step 4: Position the marquee on top of the main cabinet so that it is facing towards the front of the game. Do not grab or hold on to the plastic sign or the metal stand offs. Use only the wooden enclosure to maneuver the marquee into position.

Step 5: Locate the marquee harness and insert into the access hole of the main cabinet. Take care that it will not get crushed when the marquee is lowered. Secure marquee top box using hardware provided.

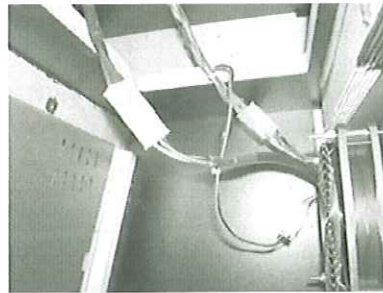

Step 6: Make the following connections: fluorescent lamp power, marquee speaker/LED signal, fan power.

Step 7: Make sure that the marquee top box is secured and not loose.

Chapter 3. Adjustments, Audits & Diagnostics

Diagnostic Menu System

Locate the *Service Button Panel*. It mounts inside the top coin door area. To access the MAIN MENU of the operator's screen, press the TEST button.

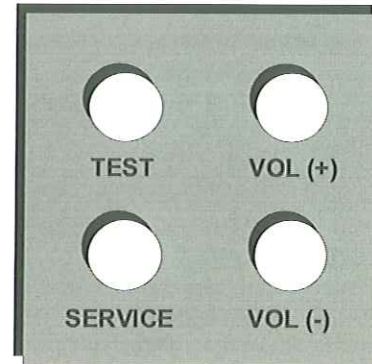

Menu Navigation

Button	Action
TEST	Enter TEST MODE screen
GREEN FRET BUTTON or TEST	Enter or Select item
VOL UP/DOWN OR STRUM UP/DOWN	Scroll UP/DOWN
SERVICE or RED FRET BUTTON	Exit or Back to previous screen

Main Menu

Main Menu

When you press the TEST button, the Main Menu appears. The Main Menu presents a number of selections that you can choose.

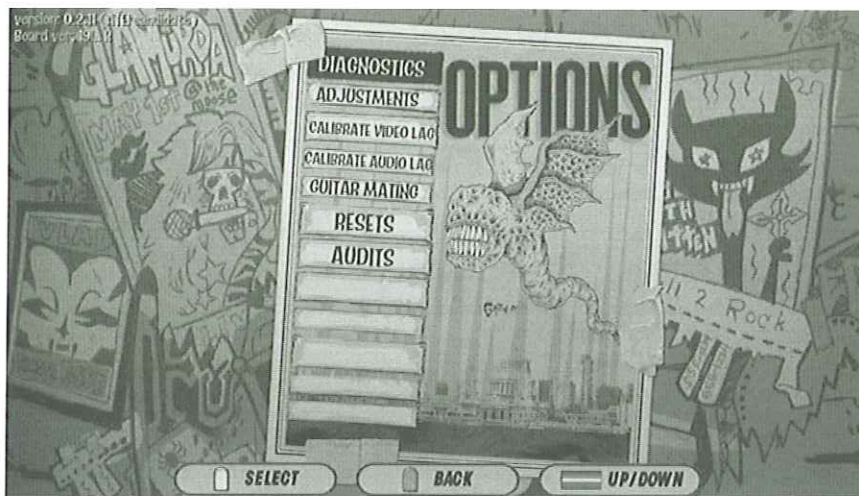

Procedure

A BAR APPEARS ON SCREEN and highlights your selection. Use STRUM BAR OR VOL (+/-) to move the highlighted bar up. Use TEST OR GREEN FRET BUTTON select menu item. Upon selection the sub-menu which corresponds to your selection will be displayed.

Menu System Map:

I: DIAGNOSTICS

SWITCH TEST

- FRET BUTTON
- LEFT/RIGHT START
- COIN
- BILL
- VOLUM UP/DOWN
- GUITAR TILT(STAR POWER)

AUDIO TEST

- MUSIC TEST
- EFFECT TEST
- 100HZ TEST
- 1000HZ TEST
- PAN LEFT
- PAN RIGHT

MONITOR TEST

- COLOR BAR
- WHITE
- RED
- BLUE
- GREEN
- CONVERGENCE

LAMP TEST

- TOGGLE ALL LAMPS
- TOGGLE MARQUEE LAMPS
- TOGGLE START LAMPS
- TOGGLE SPEAKER LAMPS

WATCHDOG TEST

COIN TEST

DIP SWITCH TEST

II: ADJUSTMENTS

- COINS PER PLAY
- COINS PER PREMIUM
- BILL PULSE
- LAMP BRIGHTNESS

III: CALIBRATE VIDEO LAG

IV: CALIBRATE AUDIO LAG

V: GUITAR MATE

VI: RESETS

- CLEAR CREDITS
- CLEAR HIGH SCORES
- CLEAR EARNING DATA
- CLEAR PLAY DATA
- CLEAR SONG DATA
- CLEAR PRICING DATA
- FACTORY RESET

VII: AUDITS

- EARNINGS DATA
- PLAY DATA
- TIME DATA
- DIFFICULTY DATA
- SONG SELECT DATA

I: Diagnostics Menu

From the Main Menu, select Diagnostics. The Diagnostics Menu opens. From here, you can select from several diagnostic tools. Select the appropriate item to verify or test functionality.

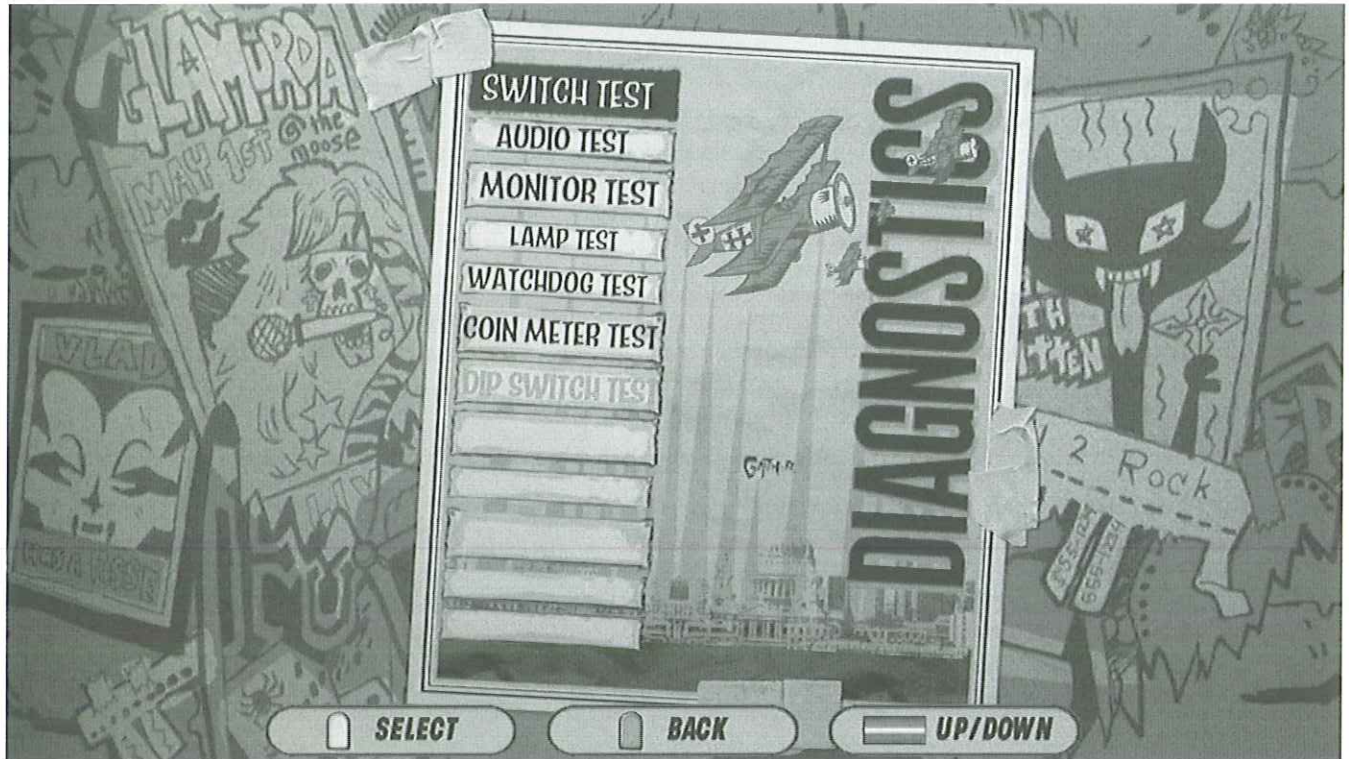

Switch Test Menu

From the Diagnostics Menu, select Switch Test. The Switch Test Menu opens. Verify that ALL switches are functional. Tilt the guitar should produce readout between 0-127 from vertical to horizontal. The number turns blue to indicate star power activation. Verify that the same is true for right handed or left handed orientation.

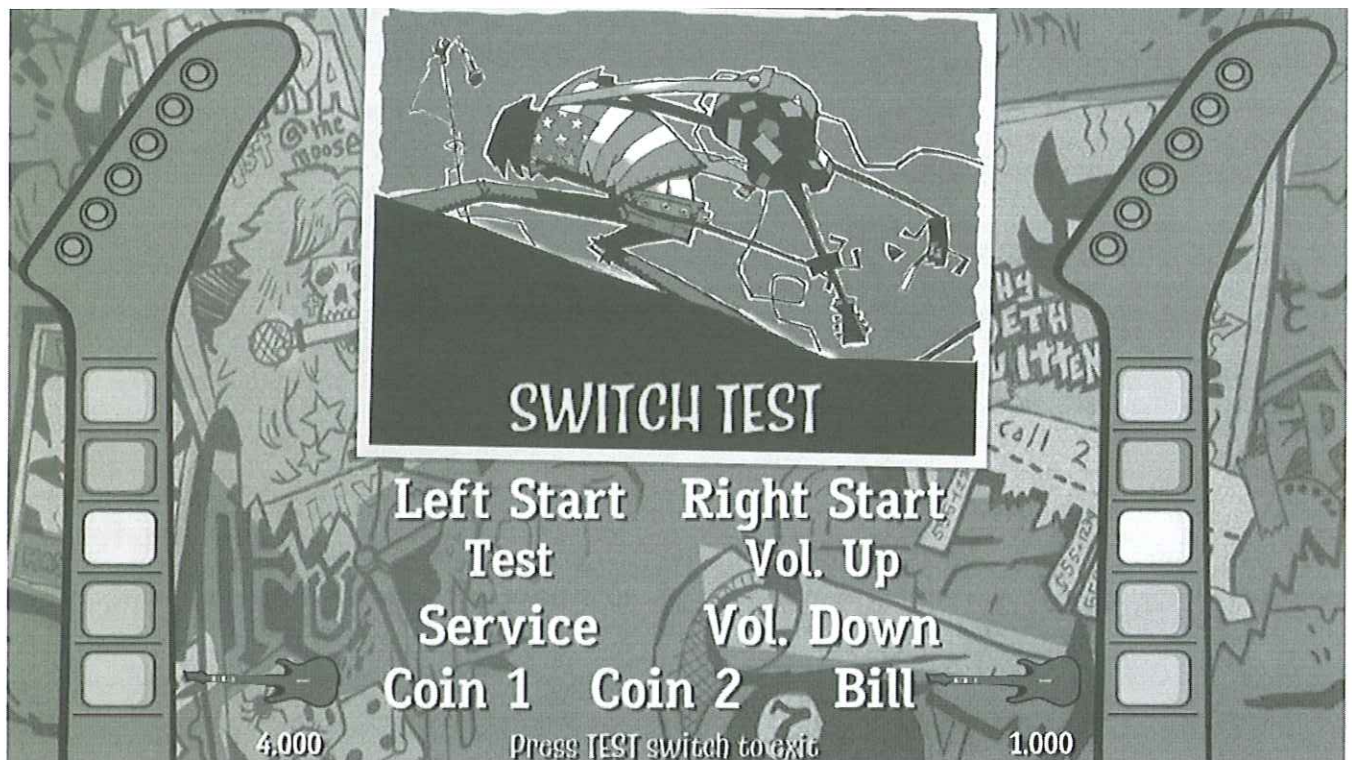

Monitor Test Menu

From the Diagnostics Menu, select Monitor Test. The Monitor Test Menu opens. From here, you can view WHITE, RED, BLU, GREEN, BLACK purity screens to detect dead pixels or similar defects. The convergence screen appears as a cross hatch screen. This helps in checking for linearity and correct size of picture. Use the color bar screen to make sure all colors are present and displayed at the appropriate levels.

Lamp Test Menu

From the Diagnostics Menu, select Lamp Test. The LampTest Menu opens. From here, you can select from several diagnostic tools. Select the appropriate item to verify or test functionality. Lamps add to the player experience and game visual appeal. It is also used to indicate visual cues such as when enough credit is available for play. Make sure that ALL lamps are in working order. Replace or repair damaged or inoperable lamps with equally rated LED (12VDC) or bulbs.

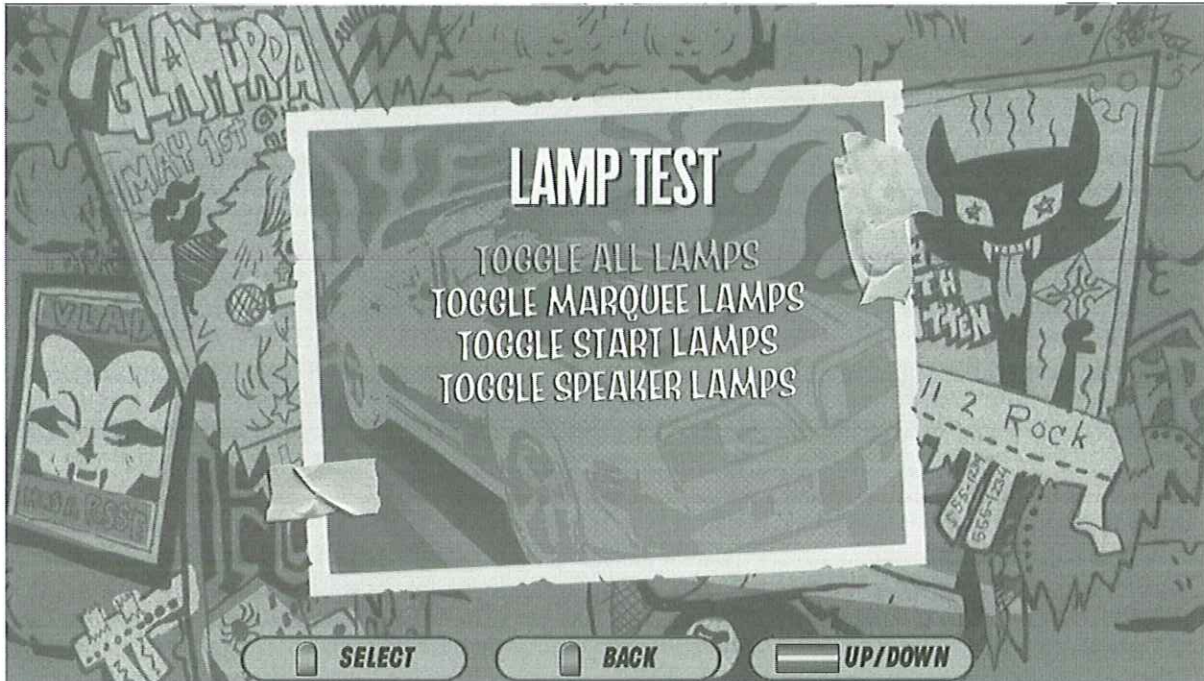

Watchdog Test Menu

From the Diagnostics Menu, select Watchdog Test. The Watchdog Test Menu opens. The watchdog circuit works to make sure that the game recovers from a locked up or frozen state without operator intervention. The game re-boots after the countdown timer reaches zero.

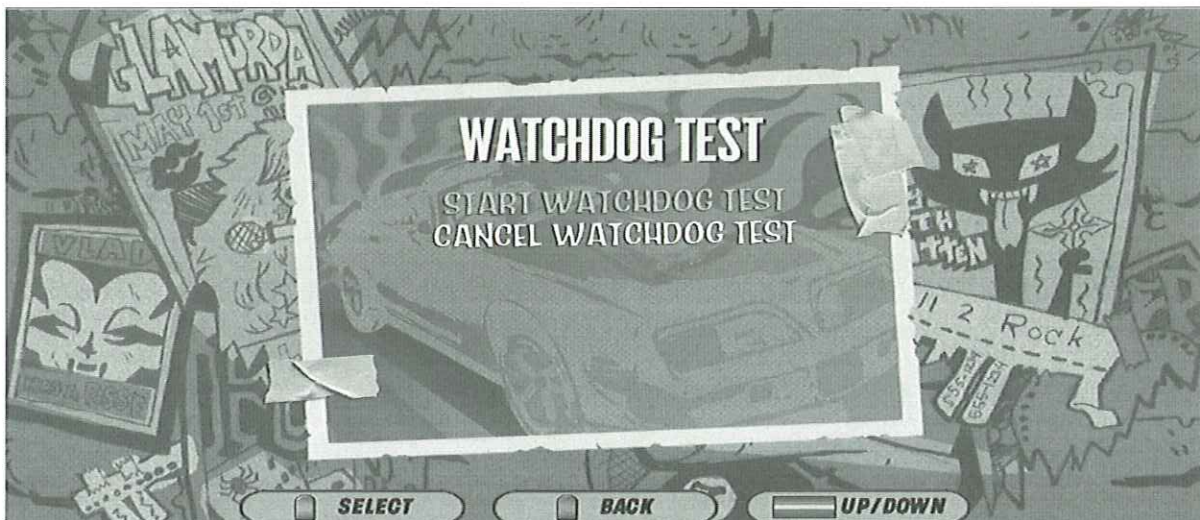

Coin Meter Test Menu

From the Diagnostics Menu, select Coin Meter Test. Advance the mechanical coin counter to make sure that it is operational. The coin meter is located on the Test/Service bracket inside the top coin door area. Press Test or the Green Fret Button to advance the meter.

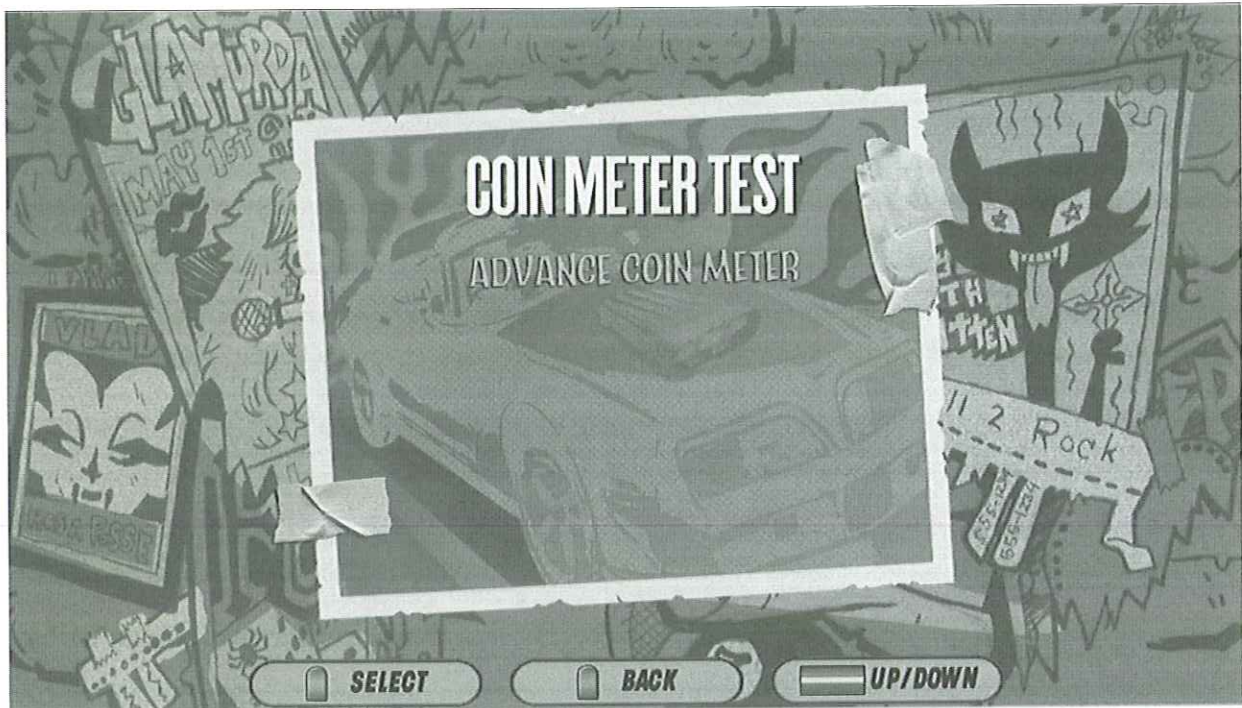

II: Adjustment Menu

From the Main Menu, select Adjustments. The Adjustments Menu opens. Adjust game pricing and lamp brightness. Default settings are as shown below.

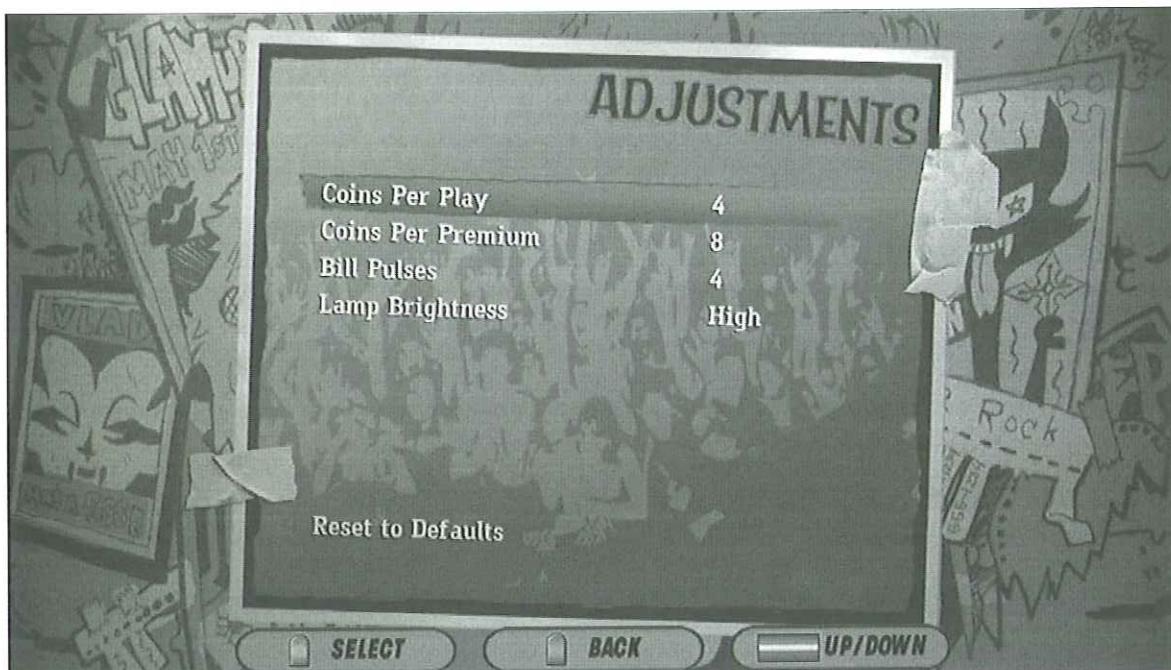

II: Calibrate Video Lag Menu

From the Main Menu, select Calibrate Video Lag. The Calibrate Video Lag Menu opens. It is recommended that this setting is set to "0 ms" for general LCD applications. This setting has been verified to be appropriate for the type of display installed on your Guitar Hero Arcade machine. Calibrate only if absolutely necessary- ie. when installing a different LCD than one shipped with the game.

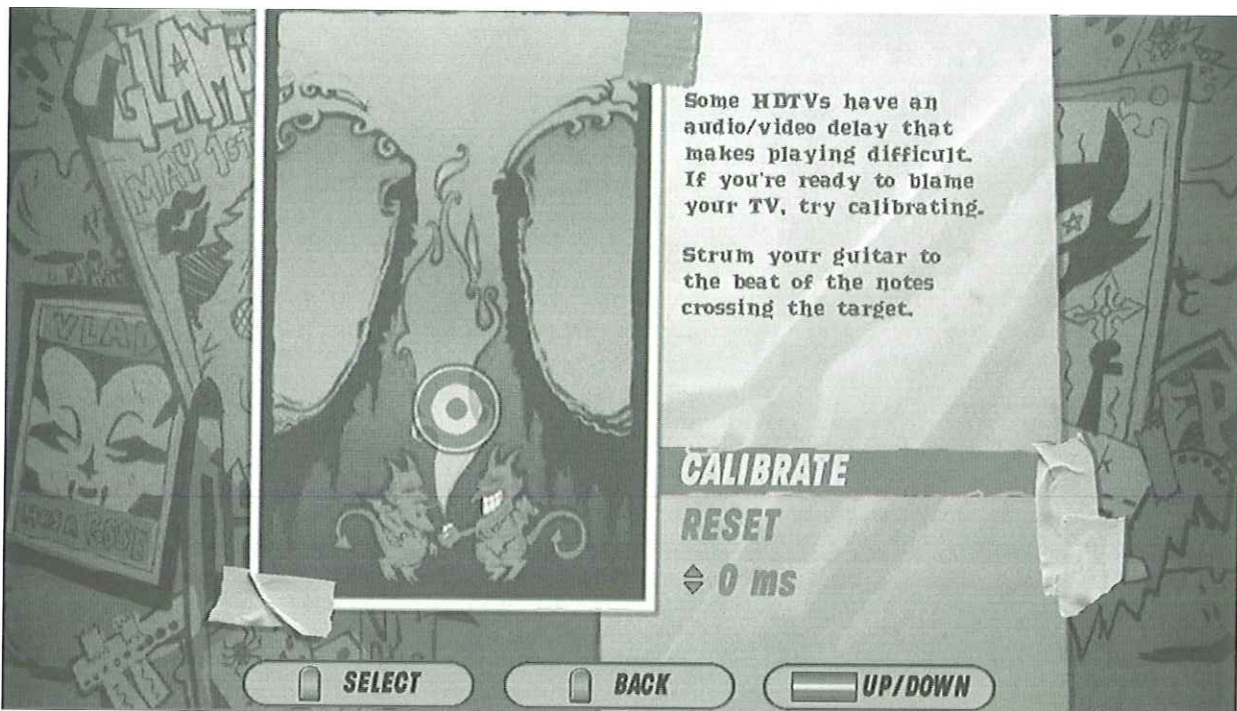

III: Calibrate Audio Lag Menu

From the Main Menu, select Audio Lag. The Audio Lag Menu opens. It is recommended that this setting is set to "100 ms" – the default setting. This setting has been verified to be appropriate for the audio hardware installed on your Guitar Hero Arcade machine. Calibrate only if absolutely necessary.

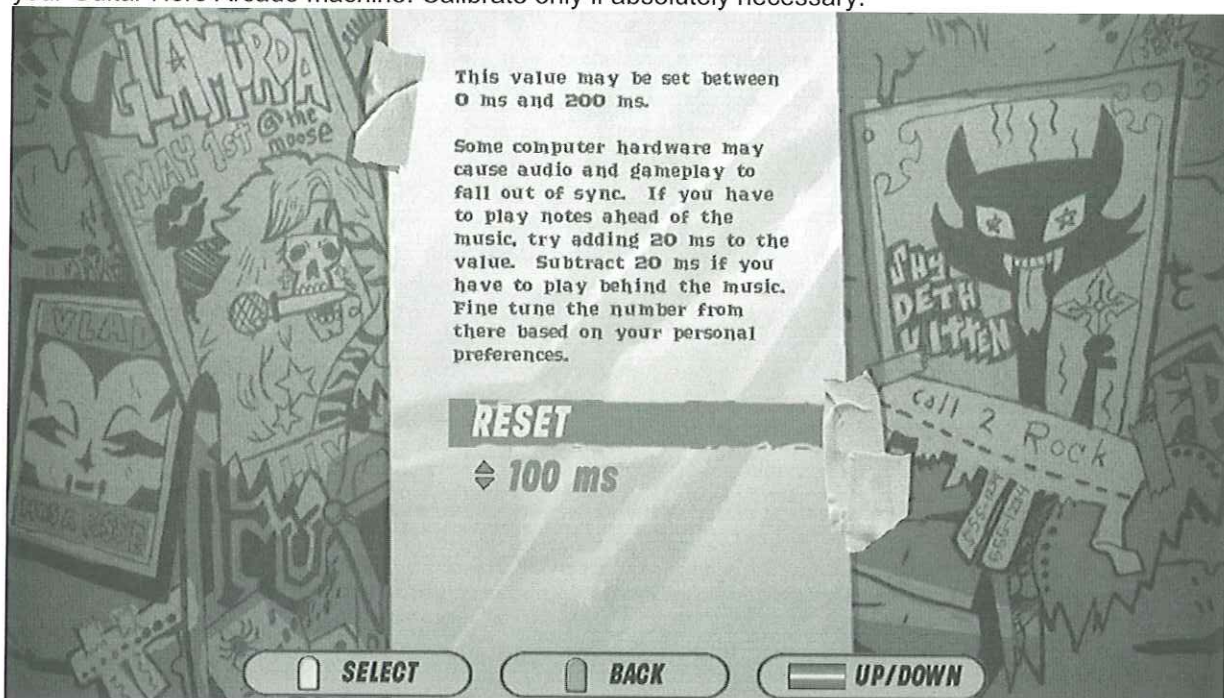

IV: Guitar Mate Menu

From the Main Menu, select Guitar Mate. The Guitar Mate Menu opens. Follow the instructions on the display to install the guitar on correct player side. This process needs to be performed when a new version of software or a new guitar is installed. This insures that the guitar is properly "mated" to the game and that the connection is a reliable one. If the guitar is not "found" or detected, simply check the USB connection to the PC and re-try the mating procedure.



V: Reset Menu

From the Main Menu, select Resets. The Reset Menu opens. The reset function when selected will clear the data for the item selected. The Factory Reset function will reset the data and also return all settings to the "default" value.

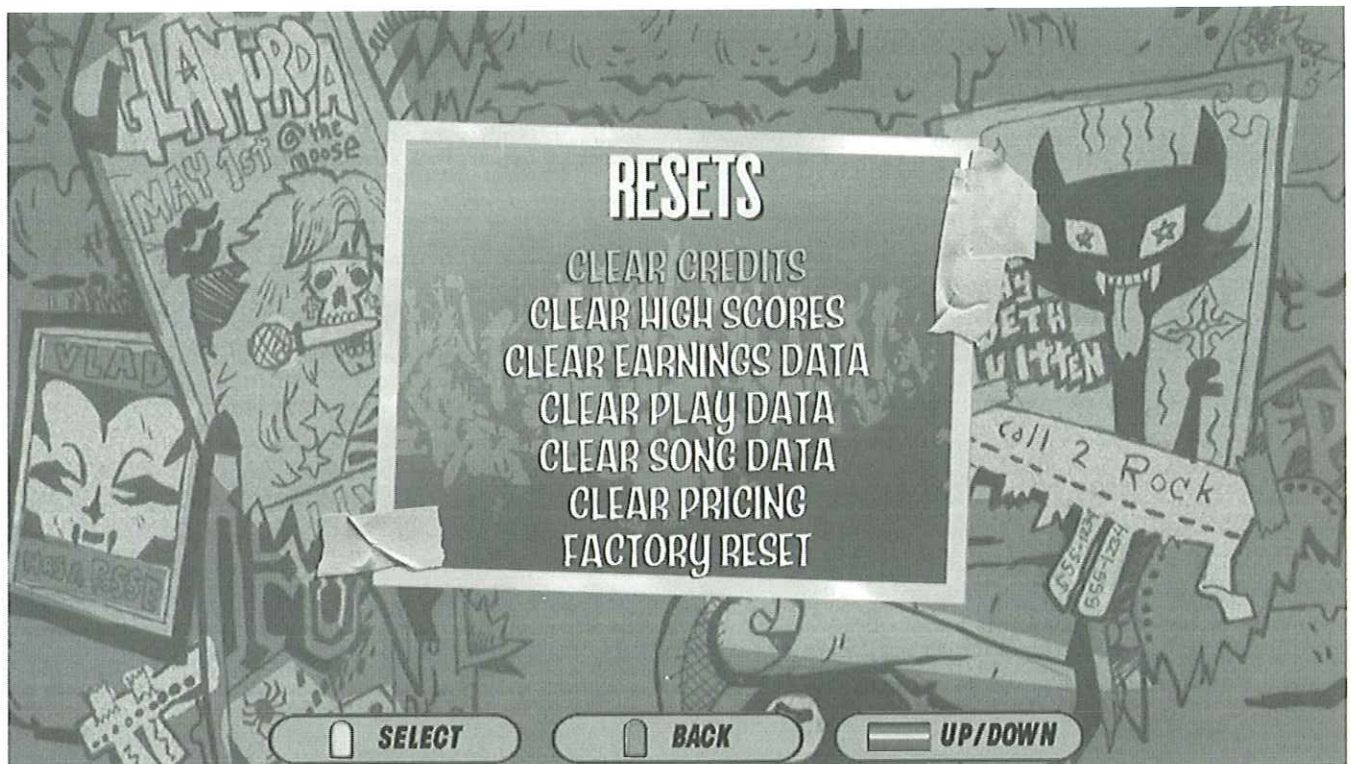

VI: Audit Menu (Audit Page 1)

From the Main Menu, select Audits. The Audit Menu opens. There are two pages available. The first page contains information relevant to game earnings, play data and operational time logs. These information are useful when assessing your games earning potential.

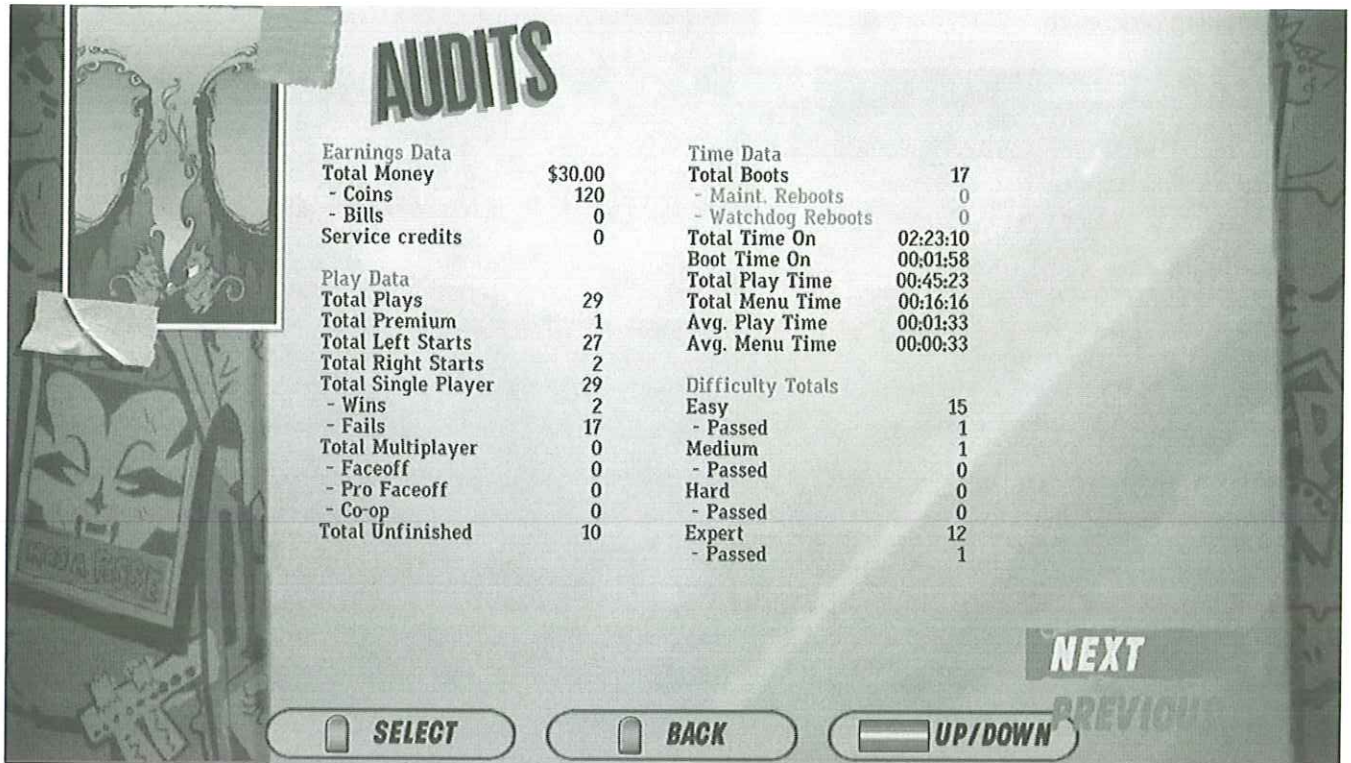

(Audit Page 2)

From the previous page, use the Strum bar to highlight NEXT. Press Test or Green Fret Button to access Audit Page 2. This page contains song specific audit information.

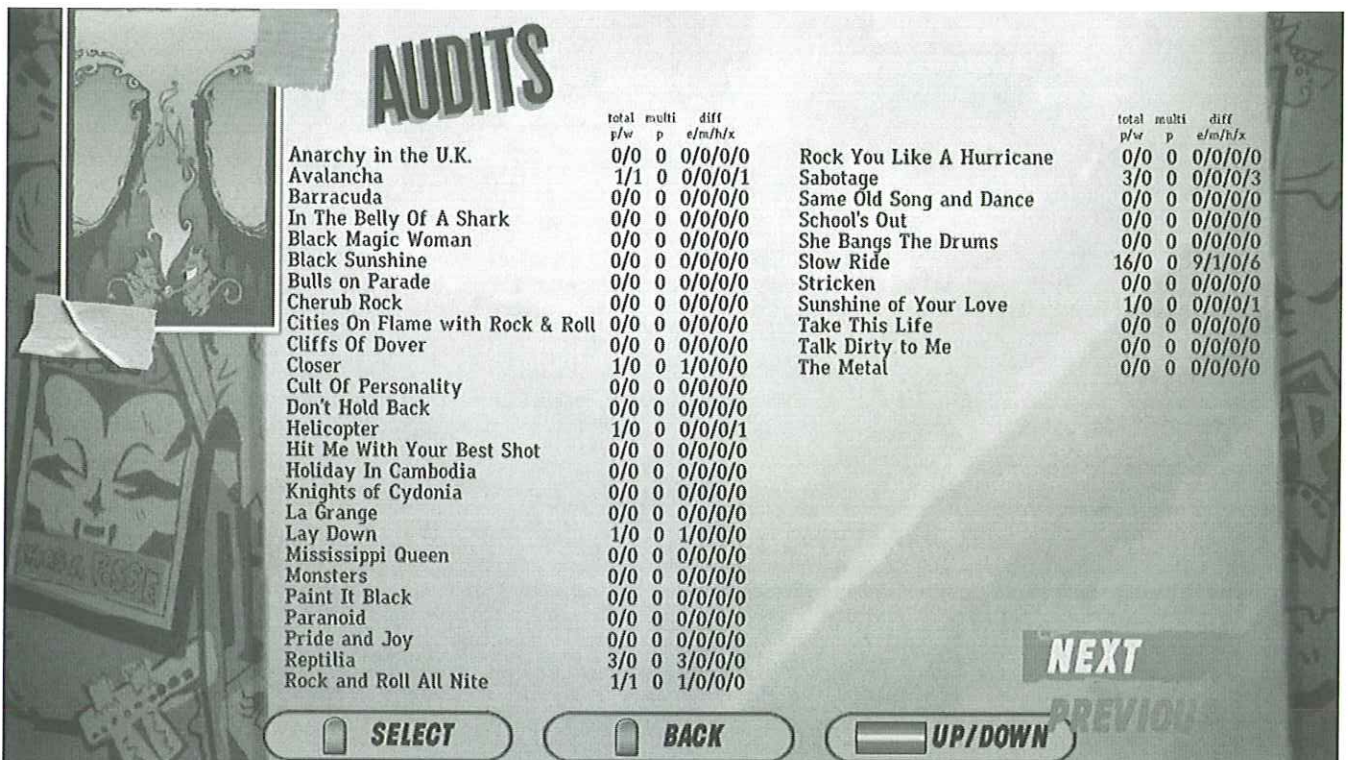

Chapter 4. Maintenance, Wiring & Troubleshooting

Hard Drive Recovery

CORRUPT FILE SCREEN. If you see the blue screen indicating an error message and the game does not load successfully, your VIDEO GAME MACHINE computer has corrupt files. To determine which files are corrupt, you can run the File Test. (See *Chapter 3, Audits, Adjustments & Diagnostics.*) The File Test can't repair corrupt files, though. The only solution is to perform a hard-drive recovery.

HERE ARE SOME SYMPTOMS of a bad hard drive:

- Hard Drive Test reports "bad" or "missing" files.
- The game fails to finish loading.
- After you cycle the power or reset the VIDEO GAME MACHINE, the VIDEO GAME MACHINE reports a error.
- The VIDEO GAME MACHINE prompts you to insert a boot DVD.
- Erratic Game Mode or Attract Mode.

NOTICE. Guitar Hero Arcade ships with a recovery DVD. Hard drives occasionally fail. If your disk fails, restore hard drive data by following this procedure. Avoid rough handling of the computer or DVD. Check the Troubleshooting Guide in this document.

From the back of the VIDEO GAME MACHINE, check the I/O board. The I/O board must have power and be connected to the computer. A serial cable connects the computer and the I/O board.

1. Verify that the I/O Board has power.
2. To access the computer, open the coin door.
3. Open the DVD tray by pressing the button on the DVD drive.
4. Insert the recovery disk into the tray.
5. Close the DVD tray by pressing the button on the DVD drive.
6. Turn-off the VIDEO GAME MACHINE via the main AC switch..
7. Turn-on the VIDEO GAME MACHINE via the main AC switch. The disk recovery process begins automatically. Recovery may take 30 to 40 minutes.
8. Look for a message at the bottom of the screen. When the recovery is over, the message prompts you to remove your disk. Open the DVD tray by pressing the DVD drive button. Remove the recovery disk. Store it safely.
9. Turn-off the VIDEO GAME MACHINE via the main AC switch.
10. Turn-on the VIDEO GAME MACHINE via the main AC switch.

© **CAUTION.** During the following process, don't interrupt power or reset the game!

11. The VIDEO GAME MACHINE will do a first-boot initialization procedure. This will take a few minutes. The VIDEO GAME MACHINE will require that the optical guns be calibrated. The VIDEO GAME MACHINE will automatically enter the gun calibration mode.

BIOS Settings / Power Management

NOTICE. Guitar Hero Arcade ships with the correct BIOS settings. Making BIOS changes will adversely affect the VIDEO GAME MACHINE.

The BIOS settings along with the functionality of the FUSE/WD board (p/n 500-00012-01) allows the main VIDEO GAME MACHINE to power correctly. The BIOS settings need to match the settings listed below. Otherwise the VIDEO GAME MACHINE will not properly recover from being turned-off, power failure, or brownout. It is also noteworthy that the FUSE/WD board makes the functionality of the power switch on the computer not function as one would expect. **Never use the power switch on the computer.** Proper power control for the VIDEO GAME MACHINE is performed by using the main AC power switch located on the lower backside of the VIDEO GAME MACHINE.

BIOS Procedure

1. Turn the game off.
2. Connect a USB keyboard to the computer.
3. While holding the [F2] key, turn on the main power switch of the VIDEO GAME MACHINE. The BIOS menu screen will appear. For a Dell Computer, verify the settings listed in the following table on the next page.
4. To save and exit, follow the instructions on the BIOS screen. The computer will reset and load the game.

LEVEL	ITEM	VALUE
SYSTEM	BOOT SEQUENCE	1. CD/DVD/CD-RW DRIVE 2. USB-ZIP 3. USB-DEVICE 4. HARDDRIVE 5. USB-FDD 6. USB-CDROM 7. NIC 8. DISKETTE DRIVE
DRIVES	DISKETTE DRIVE	USB
DRIVES	DRIVE 0:	SATA-0: ON
DRIVES	DRIVE 1:	SATA-1: ON
DRIVES	SMART REPORTING	OFF
ONBOARD DEVICES	INTEGRATED NIC	ON
ONBOARD DEVICES	INTEGRATED AUDIO	ON
ONBOARD DEVICES	USB CONTROLLER	ON
ONBOARD DEVICES	REAR TRIPLE USB	ON
ONBOARD DEVICES	REAR DUAL USB	ON
ONBOARD DEVICES	FRONT USB	ON
ONBOARD DEVICES	LPT PORT MODE	EPP
ONBOARD DEVICES	LPT PORT ADDRESS	378H
ONBOARD DEVICES	SERIAL PORT #1	COM1
VIDEO	PRIMARY VIDEO	ONBOARD/CARD
VIDEO	VIDEO MEMORY SIZE	16MB
PERFORMANCE	HDD ACOUSTIC MODE	BYPASS
SECURITY	ADMIN PASSWORD	NONE
SECURITY	SYSTEM PASSWORD	NONE
SECURITY	DRIVE 0 PASSWORD	NONE
SECURITY	DRIVE 1 PASSWORD	NONE
SECURITY	PASSWORD CHANGES	UNLOCKED
SECURITY	CHASSIS INTRUSION	OFF
POWER MANAGEMENT	AC RECOVERY	ON
POWER MANAGEMENT	AUTO POWER-ON	OFF
POWER MANAGEMENT	LOW POWER MODE	OFF
POWER MANAGEMENT	REMOTE WAKE-UP	OFF
POWER MANAGEMENT	COOL AND QUIET	OFF
POWER MANAGEMENT	SUSPEND MODE	S3
MAINTENANCE	ASF MODE	OFF
MAINTENANCE	FAST BOOT	ON
POST BEHAVIOR	NUMLOCK KEY	ON
POST BEHAVIOR	POST HOTKEYS	SETUP & BOOT MENU
POST BEHAVIOR	KEYBOARD ERRORS	DO NOT REPORT

Troubleshooting Guide

♦ **WARNING. Remove all power and disconnect AC line cord to VIDEO GAME MACHINE before servicing!** Service performed by qualified service technician only. With power on do not connect or disconnect cables or connectors, damage to the VIDEO GAME MACHINE will occur.

VIDEO GAME MACHINE Fails To Power-up

The VIDEO GAME MACHINE will be in this failure mode when either the main AC power has failed, been disconnected, or the computer has failed to turn-on. The computer provides +5VDC and +12VDC for the VIDEO GAME MACHINE. Turning on the computer is controlled by the FUSE/WD board, p/n 500-00012-01.

1. Verify the VIDEO GAME MACHINE power switch is on.
2. Verify the AC line cord is plugged into a functional AC outlet.
3. Verify the AC outlet is the correct voltage for the VIDEO GAME MACHINE.
4. Verify the VIDEO GAME MACHINE is set to the correct voltage. There is a voltage switch on the computer that needs to be set correctly. If this switch is set incorrectly and the VIDEO GAME MACHINE has been powered, damage to the computer may have occurred.
5. Verify the main AC power fuse for the VIDEO GAME MACHINE. This can be found on the lower back side of the VIDEO GAME MACHINE by the main power switch. If a fused failed, examine the VIDEO GAME MACHINE for a fault condition and repair the condition before replacing the fuse. For Continued protection, replace the fuse with identical UL rated fuse.
6. Verify the fuses on the FUSE / WD board, p/n 500-00012-01. These fuses protect the +5VDC and +12VDC power rails of the VIDEO GAME MACHINE. If a fused failed, examine the VIDEO GAME MACHINE for a fault condition and repair the condition before replacing the fuse. For Continued protection, replace the fuse with identical UL rated fuse.
7. Verify cable connectors inside the VIDEO GAME MACHINE. Look for cable connectors that are loose or not connected.
8. Contact _____ for additional service. You may have a failed computer or FUSE/WD board.

VIDEO GAME MACHINE Displays “NO VIDEO” Message On The Video Monitor

The VIDEO GAME MACHINE will display this message when the video display is powered but the video monitor has no valid video signal.

1. Verify the VIDEO GAME MACHINE is set to the correct voltage. There is a voltage switch on the computer that needs to be set correctly. If this switch is set incorrectly and the VIDEO GAME MACHINE has been powered, damage to the computer may have occurred.
2. Verify cable connections inside the VIDEO GAME MACHINE, including the video and power cables of the computer, I/O board, FUSE/WD board and monitor.
3. Verify the fuses on the FUSE / WD board, p/n 500-00012-01. These fuses protect the +5v and +12v power rails of the VIDEO GAME MACHINE. If a fused failed, examine the VIDEO GAME MACHINE for a fault condition and repair the condition before replacing the fuse. Replace fuse with identical UL rated fuse.
4. Verify the I/O board has power.
5. Verify the FUSE/WD board has power. The +5VDCSTBY LED indicator should be on.
6. Verify the FUSE/WD board is running. There is a green LED indicator that should be blinking.
7. Contact _____ for additional service. You may have a failed computer, FUSE/WD board or I/O board.

VIDEO GAME MACHINE Displays No Video On The Video Monitor

The VIDEO GAME MACHINE will exhibit this failure when either the VIDEO GAME MACHINE is not powered, the monitor is not powered, the monitor is not correctly adjusted or the video monitor has failed.

1. Verify the VIDEO GAME MACHINE has powered-up. If not see '**VIDEO GAME MACHINE Fails To Power-up**' in this troubleshooting section for more details.
2. Verify the cable connectors inside the VIDEO GAME MACHINE, paying close attention to the power and video signal cables of the video monitor.
3. Verify the video monitor has AC power.
4. Verify the contrast and brightness settings of the monitor. Make sure they are not set too low.
5. Contact _____ for additional service. You may have a failed monitor.

VIDEO GAME MACHINE Has No Sound

If the game is running and there is no sound.

1. Verify that the audio levels are set to acceptable levels. This can be done through the *Diagnostic Menu System*.
2. Verify the cable connections inside the VIDEO GAME MACHINE. Ensure that the audio cable from the computer is connected to the I/O board.
3. Verify the speaker cable is connected.
4. Verify the fuses on the FUSE / WD board, p/n 500-00012-01. These fuses protect the +5v and +12v power rails of the VIDEO GAME MACHINE. If a fuse failed, examine the VIDEO GAME MACHINE for a fault condition and repair the condition before replacing the fuse. Replace fuse with identical UL rated fuse.
5. Verify the I/O board has power.
6. Contact _____ for additional service. You may have a failed audio system.

VIDEO GAME MACHINE Monitor Displays 'MISSING I/O'

If the computer is unable to communicate with the I/O board, the 'Connect I/O' message will be displayed in the video display.

1. Verify that the I/O board has power. Check the fuses on the FUSE / WD board, p/n 500-00012-01.
2. Verify the cable connections inside the VIDEO GAME MACHINE. Verify the serial cable that connects the I/O board to the computer is securely attached.
3. Power-cycle the VIDEO GAME MACHINE.
4. Contact _____ for additional service. You may have a failed I/O board.

VIDEO GAME MACHINE Monitor Displays 'INSERT DONGLE'

This message indicates that the computer is unable to communicate with the security dongle that is located on the back of the computer.

1. Verify that the security dongle is attached to a USB port of the computer.
2. Contact _____ for additional service. You may have a failed security dongle or a USB port on the computer.

VIDEO GAME MACHINE Game Play is Slow, Freezes, or Resets.

Numerous items can cause game play to exhibit freezing or slow play. Typical failure modes include excessive heat, corrupt drive, or failing hardware.

1. Verify that the security dongle is attached to a USB port of the computer.
2. Verify cable connections inside the VIDEO GAME MACHINE. Verify the serial cable that connects the I/O board to the computer is securely attached.
3. Verify that the VIDEO GAME MACHINE is not running excessively hot. Verify that the cooling fan at the top of the VIDEO GAME MACHINE is running and not obstructed. The back of the VIDEO GAME MACHINE must be at least one foot away from a wall in order to allow the vents on the VIDEO GAME MACHINE to breathe.
4. Verify that the computer is not running excessively hot. Verify that the computers cooling fans are running.
5. Verify the drive. This can be done via the Operators Menu. The drive can be re-imaged, by inserting the CD that was included with the VIDEO GAME MACHINE. See '**Drive Recovery Procedure**' for instructions.
6. Verify that the games +5VDC +12VDC power rails are within +/- 5% tolerance.
7. Incorrect lamps in the coin door can cause the VIDEO GAME MACHINE to reset. Verify that the bulbs are 12 volt DC rated.
8. Contact _____ for additional service.

VIDEO GAME MACHINE Guitars Do Not Work Properly As part of VIDEO GAME MACHINE setup, you must mate the guitars for the following reasons:

Refer to Guitar Mating section of this manual for procedure.

- a) one or both guitars were not connected to the PC during power up
- b) the guitars were swapped due to service or troubleshooting
- c) a new guitar is being installed which has not been previously installed in any game

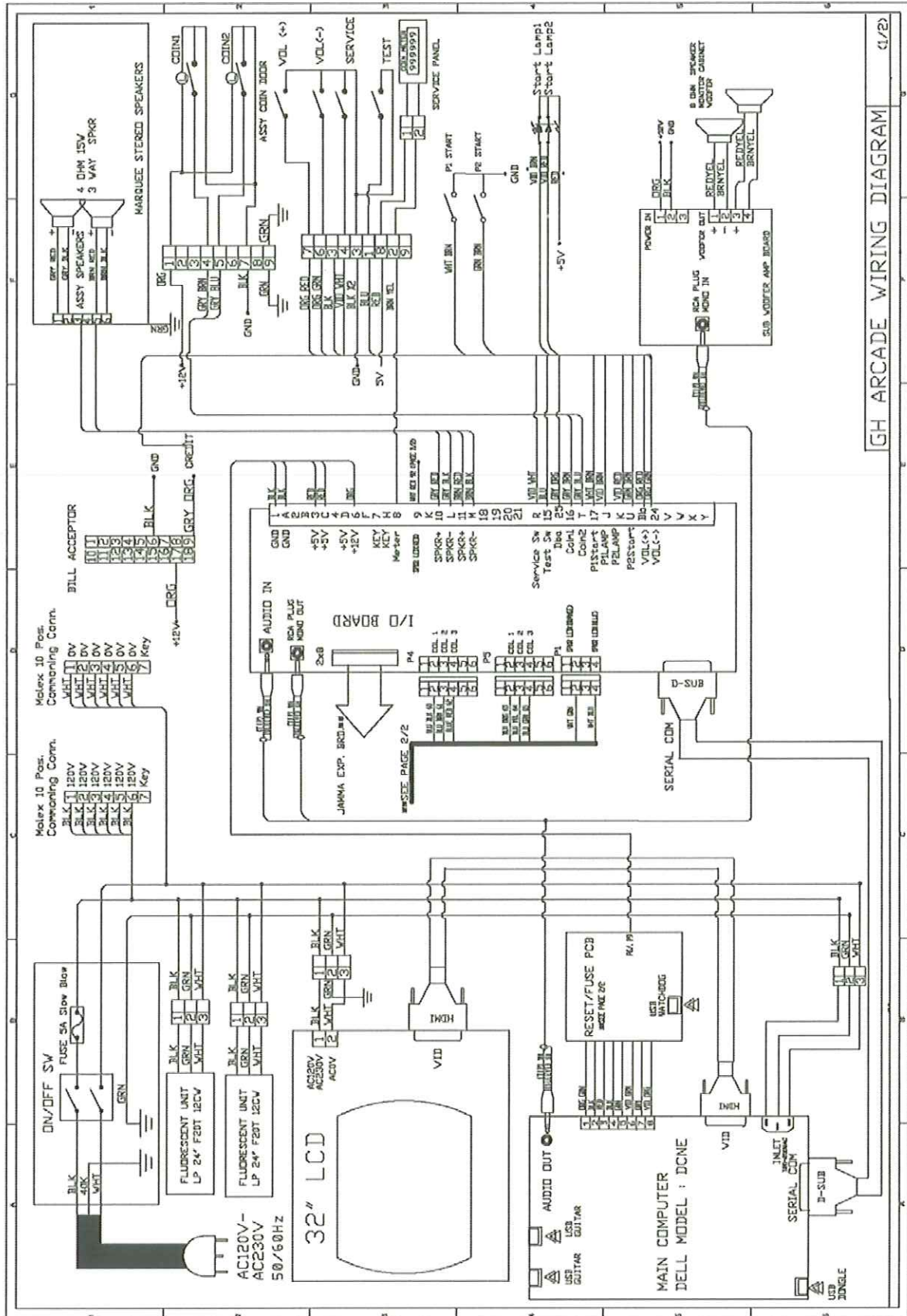

GH ARCADE WIRING DIAGRAM (1/2)

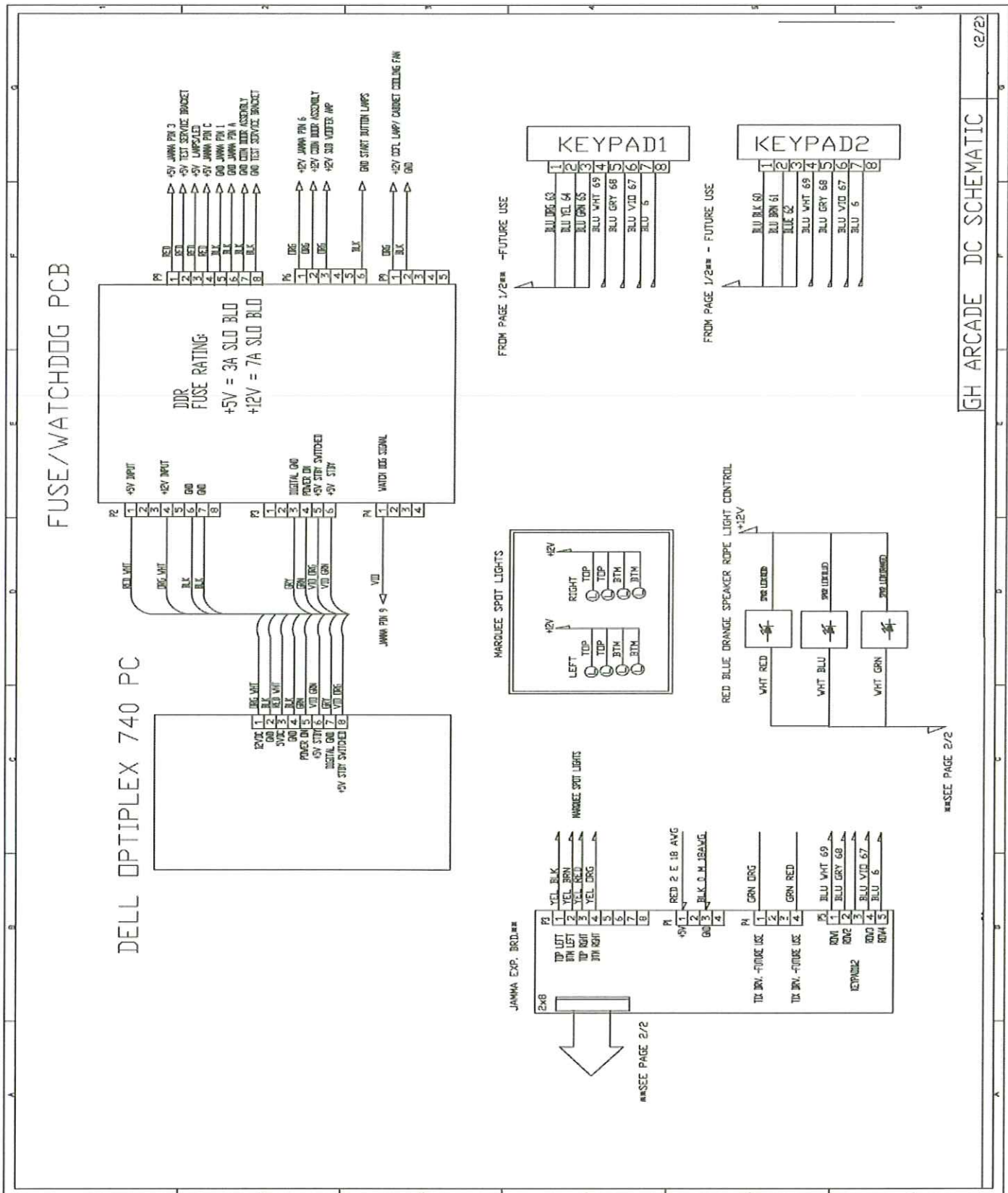

Chapter 5. Parts

Guitar Parts

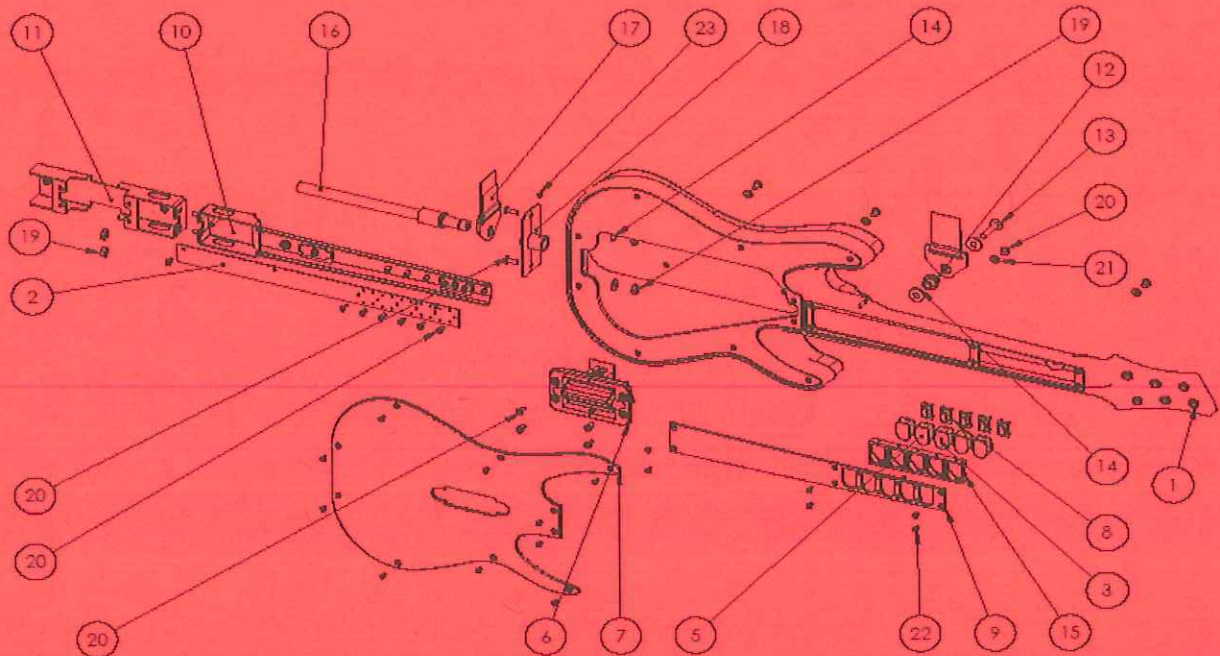

ITEM NO.	PART NUMBER	DESCRIPTION	QTY.
1	603-00037-01	Guitar Hero, Guitar	1
2	500-00022-02	Fret PCB	1
3	603-00038-01	Fret, Push Button (Yellow)	1
5	603-00038-02	Fret, Push Button (Green)	4
6	Strum Bar Assembly 3 - sintered bearing		1
7	606-00089-01		1
8	603-00042-01	Rubber key of RedOctane guitar controller	5
9	608-00028-01	Guitar Fret Cover Plate	1
10	608-00030-01	Chassis - Guitar Neck	1
11	608-00029-01	Chassis - Guitar Body	1
12	Metal Bushing guitar freaks		1
13	CR-FHMS 0.25-20x1.25x1.25-C		1
14	Regular FW 0.19		4
15	600-00113-01	Guide Block (5-button)	1
16	Brass Bushing (shotgun hose)		1
17	600-00112-01	Guitar Strap	2
18	600-00090-01	Cover Plate - Hose & Strap	1
19	MSHXNUT 0.216-24-S-N		4
20	CR-FHMS 0.19-32x0.5x0.5-N		17
21	Narrow FW 0.19		4
22	CR-FHMS 0.138-32x0.25x0.25-C		16
23	SSCOILNLSKT 0.164-32x0.25-HX-C		1



Guitar Hero Arcade © 2007-2008 Activision Publishing, Inc. Guitar Hero, Activision and RedOctane are registered trademarks of Activision Publishing, Inc. Covered by one or more of the following patents: U.S. Patent Nos. 5,739,457, 6,018,121, 6,225,547, 6,268,557, 6,347,998, 6,369,313, 6,390,923, 6,425,822, 6,554,711, 6,645,067, 6,607,446, 6,609,979, 6,612,931, 6,638,160, 6,769,689, 6,821,203, 6,835,887, 6,915,488 and 6,225,547; patents pending. Certain technology and cabinet design © 2008 Konami Digital Entertainment. Distributed by Konami Digital Entertainment, Inc. under license from Activision Publishing, Inc. KONAMI is a registered trademark of KONAMI CORPORATION. All other trademarks and trade names are the properties of their respective owners. All rights reserved.