

SERVICE MANUAL



DELUXE TYPE



IMPORTANT!

Before using this product, read this SERVICE MANUAL carefully to understand the contents stated herein. After reading this manual, be sure to keep it available nearby the product or somewhere convenient in order to be able to refer to it whenever necessary.

Manufactured in the UK by



CONTENTS

| | | |
|----------|--|----|
| 1. | BEFORE USING THIS PRODUCT | 1 |
| 1.1. | INSPECTIONS IMMEDIATELY AFTER TRANSPORTING THE PRODUCT TO THE LOCATION | 2 |
| 2. | INTRODUCTION TO THIS SERVICE MANUAL | 4 |
| 3. | INSTALLATION AND SERVICE INSTRUCTIONS | 5 |
| 3.1. | HANDLING AND INSTALLATION PRECAUTIONS | 5 |
| 3.2. | COIN HANDLING | 5 |
| 3.3. | NAME OF PARTS | 6 |
| 3.4. | ACCESSORIES | 7 |
| 3.5. | SHIPPING THE GAME BOARD | 8 |
| 3.6. | SHIPPING THE MEDIA BOARD | 10 |
| 3.7. | SHIPPING THE GD-ROM DRIVE | 11 |
| 3.8. | ASSEMBLY INSTRUCTIONS | 12 |
| 3.8.1. | ASSEMBLE THE MACHINE | 13 |
| 3.8.1.1. | ASSEMBLE THE PTV | 13 |
| 3.8.1.2. | ATTACH THE GUARD RAILS | 14 |
| 3.8.1.3. | ATTACH GUN PANELS TO GUN CABINET | 14 |
| 3.8.1.4. | ATTACH THE GUN CABINET | 15 |
| 3.8.1.5. | FIT THE BILLBOARD TO THE PTV | 16 |
| 3.8.2. | LEG-LEVELLING PROCEDURE | 17 |
| 3.8.3. | COIN HANDLING INSTALLATION | 18 |
| 3.8.3.1. | WIRING CONNECTIONS | 19 |
| 3.8.4. | CONNECTION TO THE POWER SUPPLY | 20 |
| 3.8.5. | ADJACENT CONTROL INTERFERENCE PREVENTION | 21 |
| 3.9. | ASSEMBLY CHECK | 22 |
| 3.9.1. | MEMORY TEST | 22 |
| 3.9.2. | C.R.T. TEST | 23 |
| 3.9.3. | INPUT TEST | 24 |
| 3.9.4. | OUTPUT TEST | 24 |
| 3.9.5. | GUN ADJUSTMENT | 25 |
| 3.10. | MOVING THE MACHINE | 26 |
| 3.11. | FUSES | 27 |
| 3.12. | REPLACEMENT OF FLUORESCENT LAMP AND OTHER LAMPS | 28 |
| 3.12.1. | FLUORESCENT LAMP REPLACEMENT | 28 |
| 3.12.2. | LAMP REPLACEMENT | 29 |
| 3.13. | TROUBLESHOOTING | 30 |
| 3.14. | CONTROLLER UNIT (SHOTGUN) | 31 |
| 3.15. | GAMEBOARD | 34 |
| 3.15.1. | REMOVING THE BOARD | 34 |
| 3.15.2. | REMOVING THE GD-ROM DRIVE | 36 |
| 3.16. | COMPOSITION OF THE GAME BOARD | 37 |
| 3.17. | PERIODIC CHECK AND INSPECTION | 38 |
| 4. | HOW TO PLAY | 39 |
| 4.1. | GAME CONTENTS | 40 |
| 4.1.1. | GAME OUTLINE | 40 |
| 4.1.2. | ITEMS | 43 |
| 4.1.3. | PLAY HINTS | 43 |
| 5. | MAINTENANCE INSTRUCTIONS | 44 |
| 5.1. | EXPLANATION OF TEST AND DATA DISPLAY | 44 |
| 5.1.1. | VTS ASSEMBLY | 46 |
| 5.2. | SYSTEM TEST MENU MODE | 47 |
| 5.2.1. | MEDIA BOARD TEST | 48 |
| 5.2.2. | SYSTEM INFORMATION | 49 |
| 5.2.3. | JVS TEST | 50 |
| 5.2.4. | INPUT TEST Screen | 51 |
| 5.2.5. | SOUND TEST | 52 |
| 5.2.6. | C.R.T. TEST | 53 |
| 5.2.7. | COIN ASSIGNMENTS | 54 |
| 5.2.8. | CLOCK SETTING | 57 |
| 5.2.9. | NETWORK SETTING (CORE) | 58 |
| 5.2.10. | NETWORK SETTING (MEDIA) | 59 |
| 5.3. | GAME TEST MODE | 63 |
| 5.3.1. | INPUT TEST | 64 |

| | | |
|----------|--|-----|
| 5.3.2. | OUTPUT TEST | 65 |
| 5.3.3. | GAME ASSIGNMENTS | 66 |
| 5.3.4. | GUN SETTING | 67 |
| 5.3.4.1. | GUN MARK CHECK..... | 68 |
| 5.3.4.2. | PLAYER1 GUN ADJUSTMENT/PLAYER2 GUN ADJUSTMENT | 69 |
| 5.3.4.3. | PLAYER1 GUN DEFAULT ADJUSTMENT/PLAYER2 GUN DEFAULT ADJUSTMENT .. | 72 |
| 5.3.5. | BOOKKEEPING..... | 73 |
| 5.3.6. | BACKUP DATA CLEAR..... | 75 |
| 6. | COIN MECH INSTALLATION AND CREDIT BOARD SET UP..... | 76 |
| 6.1. | INTRODUCTION..... | 76 |
| 6.1.1. | PRICE OF PLAY SETTINGS UK | 78 |
| 6.1.2. | PRICE OF PLAY SETTINGS EURO | 79 |
| 6.1.3. | PRICE OF PLAY SETTINGS Austria-Czech-Denmark-Norway-Israel-France2 | 80 |
| 7. | DESIGN RELATED PARTS..... | 81 |
| 8. | PARTS LIST | 82 |
| 8.1. | HDT-0000UK - TOP ASSY HOUSE OF THE DEAD3 DX | 82 |
| 8.2. | HDT-0500UK - ASSY PTV | 83 |
| 8.3. | HDT-0520UK - ASSY BILLBOARD DX..... | 84 |
| 8.4. | SPX-0530UK ASSY MASK | 85 |
| 8.5. | HDT-1000UK ASSY PTV CABI DX..... | 86 |
| 8.6. | HDT-1060UK ASSY LID UPPER | 88 |
| 8.7. | HDT-1070UK ASSY LID LOWER | 89 |
| 8.8. | HDT-1100UK ASSY CONTROLLER CABINET | 90 |
| 8.9. | HDT-1150UK ASSY FENCE L | 92 |
| 8.10. | HDT-1160UK ASSY FENCE R..... | 93 |
| 8.11. | HDT-2000UK ASSY CTRL PANEL DX | 94 |
| 8.12. | HDT-2100 CONTROL UNIT | 95 |
| 8.13. | SENSOR UNIT (JPT-2030)..... | 96 |
| 8.14. | HDT-2180UK ASSY GUN HOLDER W/TETHER L | 97 |
| 8.15. | HDT-2190UK ASSY GUN HOLDER W/TETHER R | 98 |
| 8.16. | HDT-4000UK ASSY MAIN BD DX..... | 99 |
| 8.17. | HDT-4200UK ASSY PWR SPLY..... | 101 |
| 8.18. | HDT-INST-DX ASSY INST KIT HDT DX..... | 102 |
| 8.19. | HOD-1020UK ASSY AC UNIT..... | 103 |
| 8.20. | HOD-1070UK ASSY SPEAKER | 104 |
| 8.21. | HDT-1530UK ASSY FAN UNIT DC UK..... | 104 |
| 9. | APPENDIX A - ELECTRICAL SCHEMATIC..... | 105 |
| 9.1. | WIRE COLOURS | 105 |
| 9.2. | ELECTRICAL SCHEMATIC | 105 |

1. BEFORE USING THIS PRODUCT

To ensure the safe usage, be sure to read the following before using the product. The following instructions are intended for the use of QUALIFIED SERVICE PERSONNEL ONLY.

If any activity is carried out on the product, this should be done only after carefully reading and sufficiently understanding the instructions.

Only qualified service personnel should carry out maintenance on the product.

Depending on the potential risk, terms such as “**WARNING!**” “**CAUTION**” and “**IMPORTANT!**” are used where an explanation is given that requires special attention. SEGA is not responsible for injury or damage caused by use in a manner contrary to the instructions given in this document.

In order to prevent accidents warning stickers and printed instructions are applied in the places where a potentially hazardous situation relating to the product could arise. Be sure to comply with these warnings.



Indicates that mishandling the product by disregarding this warning will cause a potentially hazardous situation that can result in death or serious injury.



Indicates that mishandling the product by disregarding this caution will cause a potentially hazardous situation that can result in personal injury and or material damage.



This is cautionary information that should be complied with when handling the product. Indicates that mishandling the product by disregarding this will cause a potentially hazardous situation that may not result in personal injury but could damage the product.

Be sure to turn off the power and disconnect from the mains supply before working on the machine.

Ensure that the correct fuses are fitted to the machine. Details of these are enclosed in the Service Manual.

Ensure that only qualified Service Engineers perform any maintenance work on the machine.

Specification changes, removal of equipment, conversion and/or additions not designated by SEGA are not permitted and will invalidate this product's CE conformity.

Warning labels or safety covers for personal protection etc, are component parts of the product. A potential hazard will be created if the machine is operated while any parts have been removed. Do not operate the product if any doors, lids or protective covers become damaged or lost. SEGA is not liable in any whatsoever for any injury and/or damage caused by specification changes not designated by SEGA.

Before installing the product, check for the Electrical Specification Sticker, SEGA products have a sticker on which the electrical specifications are detailed. Ensure that the product is compatible with the power supply voltage and frequency requirements of the location in which the machine is to be installed.

Install and operate the machine only in places where appropriate lighting is available, allowing warning stickers to be clearly read.

To ensure maximum safety for customers and operators, stickers and printed instructions describing potentially hazardous situations are applied to potentially hazardous locations. Ensure that the product's operating location has sufficient lighting to allow any warnings to be read. If any sticker or printed warning is removed or defaced, do not operate the machine until an identical item has replaced it.

Exercise great care when handling the monitor (applies only to product with monitor). Some of the monitor (TV) parts are subject to high-tension voltage. Even after turning the power off some components are liable to high-tension voltage. Only qualified service engineers should perform monitor repair and replacement.

In cases where commercially available monitors and printers are used, only the items relating to this product are contained in this manual. Some commercially available equipment will have functions and reactions not referred to in this manual. This manual should be read in conjunction with the specific manufacturer's manual for such equipment.

Descriptions contained herein may be subject to change without prior notification.

The contents described herein are fully prepared with due care. However, should any question arise or errors be found please contact **SEGA AMUSEMENTS EUROPE LTD**.

Descriptions contained herein may be subject to change without prior notification.

The contents described herein are fully prepared with due care. However, should any question arise or errors be found please contact SEGA.

1.1. INSPECTIONS IMMEDIATELY AFTER TRANSPORTING THE PRODUCT TO THE LOCATION



- Only QUALIFIED SERVICE PERSONNEL should carry out inspection.

Normally, at the time of shipment, SEGA products are in a state to allowing usage immediately after transporting to the location. Nevertheless, an irregular situation may arise during transportation preventing this. Before turning on the power, check the following points to ensure that the product has been transported safely.

- Are there any dented parts or defects (cuts, etc.) on the external surfaces of the product.?
- Are castors and leg adjusters present and undamaged?
- Do the power supply voltage and frequency requirements meet with the local supply?
- Are all wiring connectors correctly and securely connected? Unless connected in the correct direction, connector connections cannot be made successfully. Do not insert connectors forcibly.
- Are all IC's of each IC BD firmly inserted?
- Does the power cord have any cuts or dents?
- Do fuses meet the specified rating?
- Are such units such as monitors, control equipment, IC BD, etc. firmly secured?
- Are all earth wires connected?
- Are all accessories available?
- Can all doors and lids be opened with the accessory keys and/or tools?

CONCERNING THE STICKER DISPLAY

SEGA product has stickers describing the product manufacture number (Serial Number) and electrical specification. If you require service assistance you will require the Serial Number. Identical machines may have different parts fitted internally. Only by quoting the Serial Number will the correct parts be identified.

CONCERNING WARNING STICKERS

SEGA product has warning displays on stickers, labels or printed instructions adhered/attached to or incorporated in the places where hazardous situations can arise. The warning displays are intended for the accident prevention of customers and service personnel.

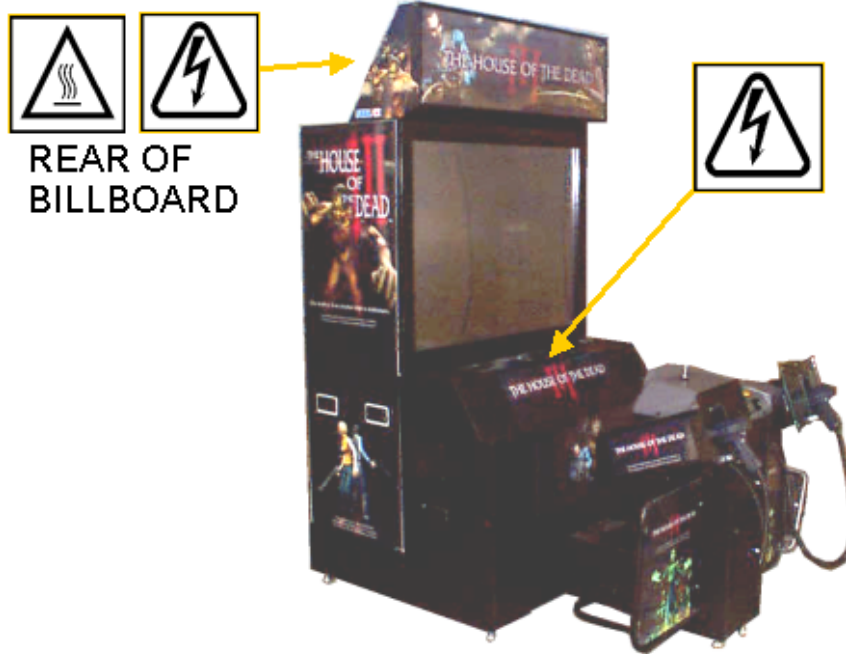

SPECIFICATIONS

Installation Space (cm): 114 x 164.6
Height (cm): 198
Weight (kg): 247

Rated Voltage (V.AC): 230/50Hz
Rated Current: 2A

Operating Temperature Range: 5-30°C

Note: Descriptions in this manual are subject to change without prior notice.

2. INTRODUCTION TO THIS SERVICE MANUAL

SEGA ENTERPRISES LTD. supported by its experience in electronic high technology of VLSI's, microprocessors etc. and with a wealth of experience, has for more than 30 years been supplying various innovative and popular games to the world market. This Service Manual is intended to provide detailed descriptions together with all the necessary information covering the general operation of electronic assemblies, electro-mechanicals, servicing controls, spare parts, etc. as regards this new SEGA product. This manual is intended for those who have knowledge of electricity and technical expertise especially in IC's, CRT's, microprocessors etc. Carefully read this manual to acquire sufficient knowledge before working on the machine. Should there be any malfunction, non-technical personnel should under no circumstances touch the internal systems. Should such a situation arise contact our head office.

SEGA AMUSEMENTS EUROPE LTD./ SEGA SERVICE CENTRE

Suite 3a
Oaks House
12 - 22 West Street
Epsom
Surrey
United Kingdom
KT18 7RG

3. INSTALLATION AND SERVICE INSTRUCTIONS



- Only QUALIFIED SERVICE PERSONNEL should carry out installation and commissioning.

3.1. HANDLING AND INSTALLATION PRECAUTIONS

When installing or inspecting the machine, be very careful of the following points and pay attention to ensure that the player can enjoy the game safely.

The game must NOT be installed under the following conditions:

- Outside, the game is designed for indoor use only.
- In areas directly exposed to sunlight, high humidity, dust, excessive heat or extreme cold.
- In locations that would present an obstacle in the case of an emergency i.e. near fire equipment or emergency exits.
- On unstable surfaces or surfaces subject to vibration.
- Where liquids, other than routine cleaning, may come into contact with the game.

Important:

- Only Qualified Service Personnel should install this machine.
- Be sure to switch the supply power OFF and remove the mains supply plug from the machine before any work is carried out on the machine.
- Do not attempt to repair the PCB's (Printed Circuit Boards) yourself. This will void the warranty. The PCB's contain static sensitive devices that could be damaged.
- Always return a faulty part to your distributor with adequate packaging and protection.
- When removing the plug from the mains always grasp the plug not the cable.
- Do not use a fuse that does not meet the specified rating.
- Make sure all connections are secure before applying power.



- Ensure that the mains lead is not damaged. If the mains lead is damaged in any way there could be a danger of electric shock or a fire hazard.
- Ensure that the power supply is fitted with circuit protection. Using the power supply without circuit protection is a fire hazard.

3.2. COIN HANDLING

Standard Sega machines are fitted with a SR3 coin mechanism, however, as a service to our customers Sega machines can be supplied with no coin mechanism or door allowing the customer to fit a coin handling option from the approved list. Fit only the coin handling arrangements detailed below and follow the instructions provided in section 3.8. Failure to fit the coin handling options detailed or failure to follow the installation instructions will render the machine, under the CE marking directive, void.

Approved coin handling options:

- Coin controls SR3
- Generic mechanical
- Mars (MS111B1 and ME115)
- SECI RM4-G20

3.3. NAME OF PARTS

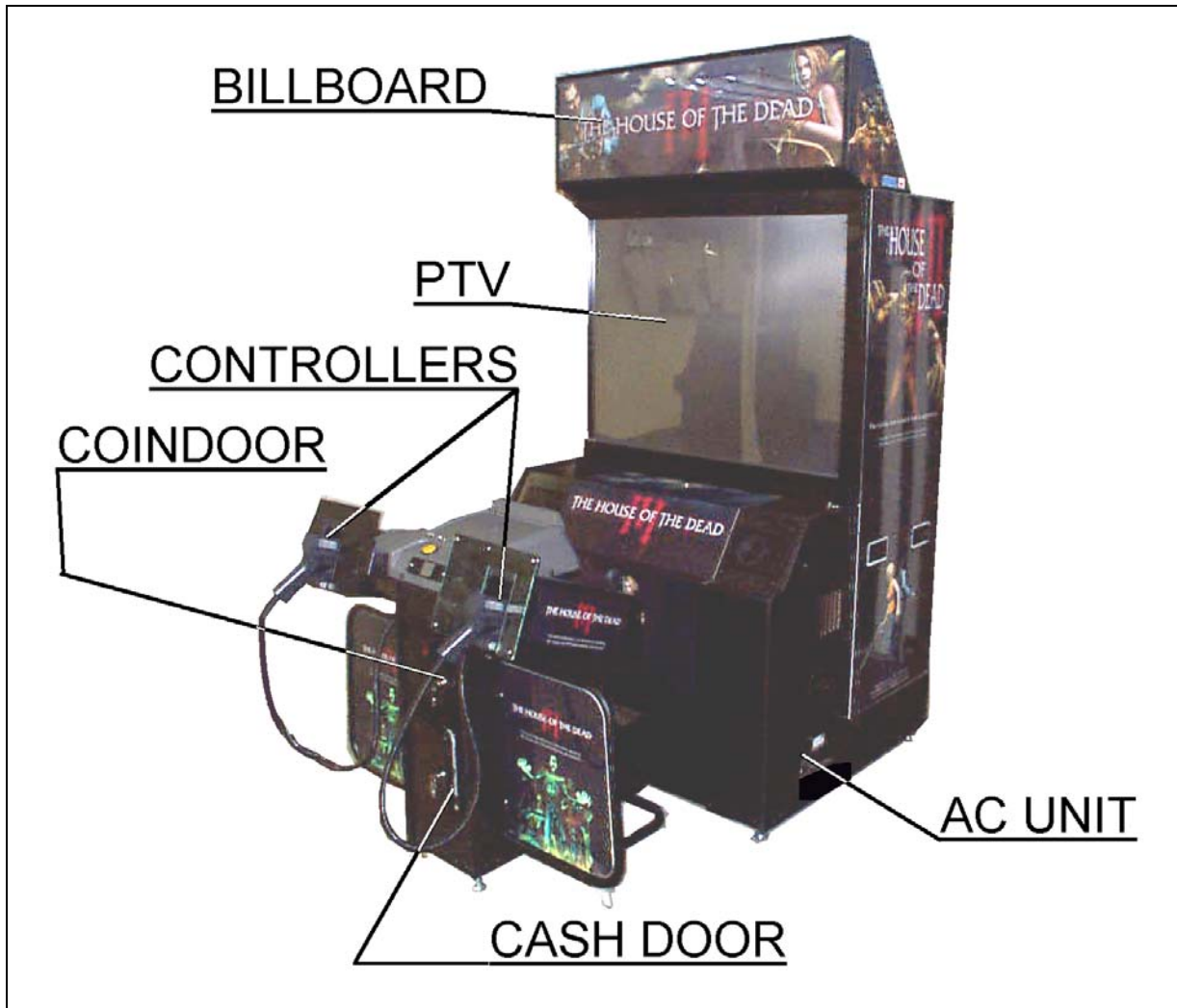

| | Width (cm) | Length (cm) | Height (cm) | Weight (kg) |
|----------------|------------|-------------|-------------|-------------|
| PTV | 114 | 53 | 158 | 91 |
| BILLBOARD | 114 | 40 | 40 | 19 |
| MAIN CABI DX | 114 | 96.8 | 93.9 | 87 |
| GUN CABI | 54.8 | 101 | 98.7 | 40 |
| When Assembled | 114 | 164.6 | 198 | 247 |

3.4. ACCESSORIES

The machine is supplied with an installation kit. Please ensure the following parts are supplied:

| Item | Component Part | Qty. | Description |
|------|----------------|------|-------------------------------|
| 1 | HDT-0520UK | 1 | ASSY BILLBOARD DX |
| 2 | HOD-0006 | 2 | L BRKT |
| 4 | 440-CS0186UK | 1 | STICKER C EPILEPSY MULTI |
| 6 | HDT-2180UK | 1 | ASSY GUN HOLDER W/TETHER L |
| 7 | HDT-2190UK | 1 | ASSY GUN HOLDER W/TETHER R |
| 22 | PK0318 | 1 | CARTON BOX INST KIT HDT DX |
| 23 | SAECE-XXX | 1 | DECLARATION OF CONFORMITY |
| 24 | HDT-2002UK | 1 | INST PLATE HDT DX MULTI |
| 101 | 290094 | 0.08 | WRAP BUBBLE (SM) 600MM X 100M |
| 201 | 030-000850-SB | 4 | M8X50 BLT W/S BLK |
| 202 | 030-000830-SB | 8 | M8X30 BLT W/S BLK |
| 203 | 029-F00625-0B | 4 | M6X25 SKT CSK BLK |
| 205 | 000-T00420-0B | 4 | M4X20 MSCR TH BLK |
| 206 | 068-441616-0B | 4 | M4 WSHR 16OD FLT BLK |
| 207 | 030-000840-SB | 8 | M8X40 BLT W/S BLK |
| 208 | 068-852216-0B | 24 | M8 WSHR 22OD FLT BLK |
| 209 | 030-000860-0B | 4 | M8X60 BLT BLK |
| 401 | 420-6620UK | 1 | SERVICE MANUAL GD ROM SYSTEM |
| 402 | OS1019 | 2 | SELF SEAL BAG 9X12.3/4 |
| 403 | 420-6742-01UK | 1 | SERVICE MANUAL HDT DX |
| 405 | 390-5160 | 1 | LAMP WG B TYPE 6V 3W (C2R) |
| 406 | 509-5080 | 2 | SW MICRO TYPE (SS-5GL2) |
| 413 | 514-5078-5000 | 1 | FUSE 5X20 CERAMIC SB 5000mA |

3.5. SHIPPING THE GAME BOARD

| | |
|---|---|
|  <p>STOP IMPORTANT</p> | <p>Replacement or repair of the Game Board (Chihiro) for this product should be undertaken at the appropriate repair centre. Be sure to follow the specifications below when requesting repairs/sending the board to the repair centre. Not following the specifications may result in the board not being accepted or in extra charges being made.</p> <ul style="list-style-type: none">• Put the game board in the carton box as is. Do not carry out any disassembly or part removal other than that specified.• Follow the procedure and instructions regarding direction below when placing the Game Board in the carton box.• When packing the game board with the Media Board attached, do not remove the Key Chip.• When packing the game board with the Media Board detached, be sure to include the AVIP Cable.• When packing, attach the accessory stickers in the specified places on the Game Board and carton box. |
|---|---|

INSTRUCTIONS

1. Wrap the Chihiro Board in a plastic bag.
2. Place it on top of the bottom surface cushioning material. Turn the Filter Board to face the side with the three honeycomb buffers. Packing it in the opposite direction may cause damage to the Filter Board.
3. Insert corrugated cardboard into the space between the lateral honeycomb buffers of the bottom surface cushioning material and stow the AVIP cable inside.
4. Place the Chihiro Board wrapped in the bottom surface cushioning material into the carton box. Use the handles on the bottom surface cushioning material.
5. Place the upper surface cushioning material on top of the Chihiro Board. Be sure to align it in the right direction, as it will not fit otherwise.
6. Close the top of the carton box and seal it tightly with adhesive tape.

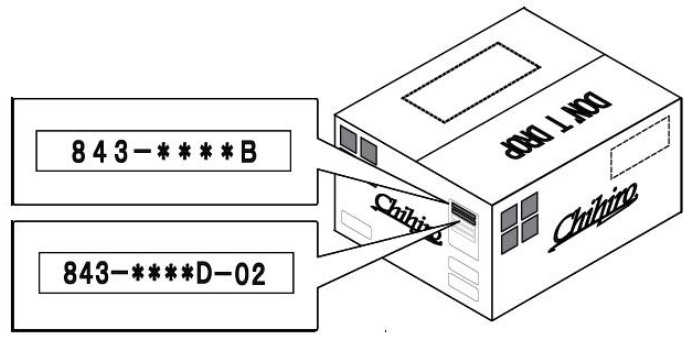
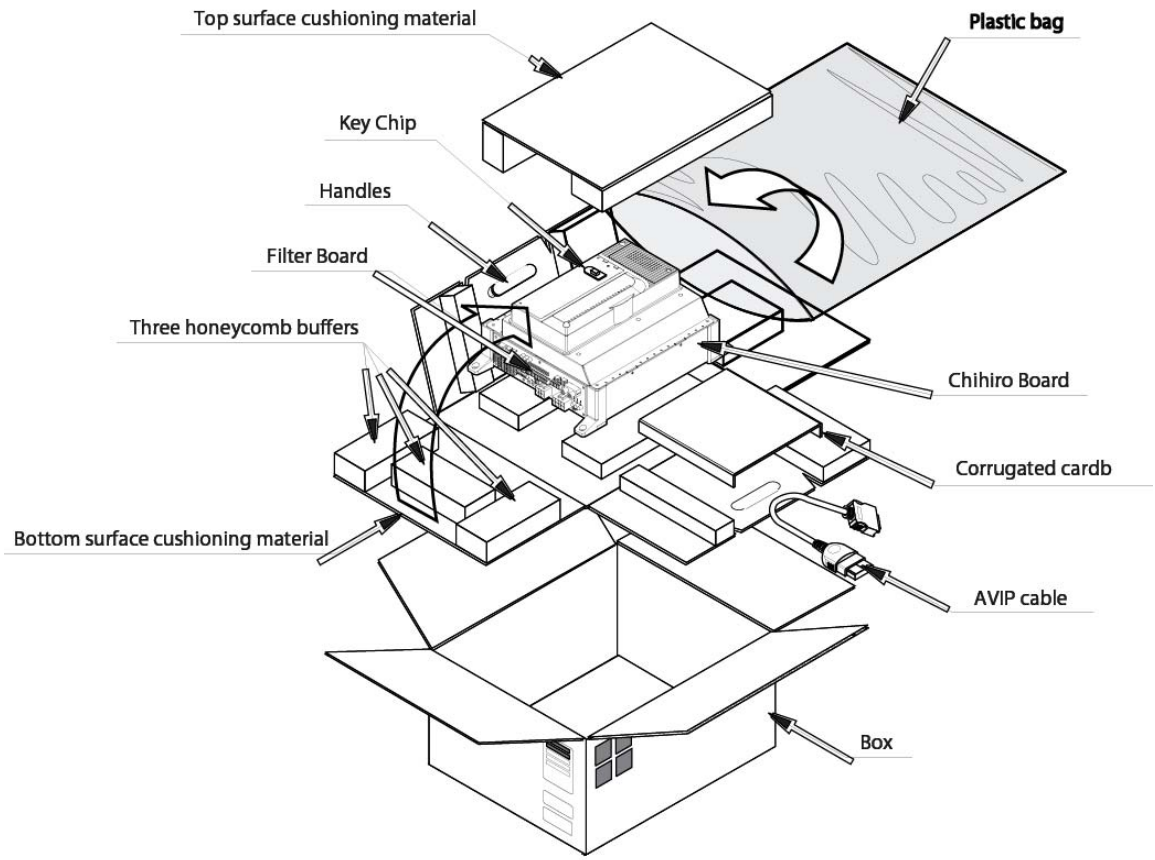

3.6. SHIPPING THE MEDIA BOARD



When sending the Media Board for repairs, follow the specifications below and request repairs or send the Board to your retailer/the repair centre.

Not following the specifications may result in the board not being accepted or in extra charges being made. Also, mistaken handling can damage or result in loss of parts.

- Be sure to use the special purpose carton box included with this product.
- Do not remove the Key Chip. Send the board with the Key Chip attached.
- Undo the 10 screws holding the Media Board to the Main Board and pack the Media Board. Do not carry out any disassembly or part removal other than that specified in this manual.
- Pack the Media Board in the special purpose carton box as shown in the explanatory diagram.
- The packing material in the carton box has a shock absorbing function. Be sure to use it when packing. Do not bend or fold the material in a direction other than that shown on the diagram.
- Do not pack any wires, cables, or screws together with the Board.
- Be sure to attach the special purpose carton box accessory sticker "843-****B."

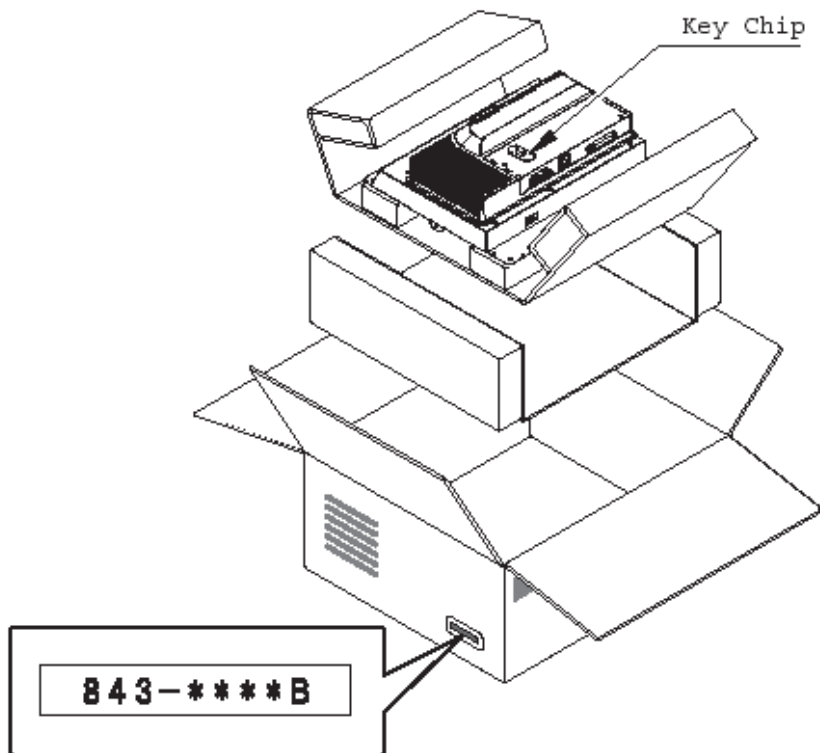

3.7. SHIPPING THE GD-ROM DRIVE



- When returning the GD-ROM DRIVE for repair or replacement, be sure to package it in the original card transit box - THERE ARE NO USER-SERVICEABLE PARTS INSIDE.
- Ensure the GD-ROM Disk is removed and the GD-ROM Drive Lid is replaced on the unit, with fixing screw, before packaging. Also, remove the GD-ROM Drive Bracket and store with the four screws for reuse.
- Failure to return the GD-ROM DRIVE in this manner may invalidate the warranty.

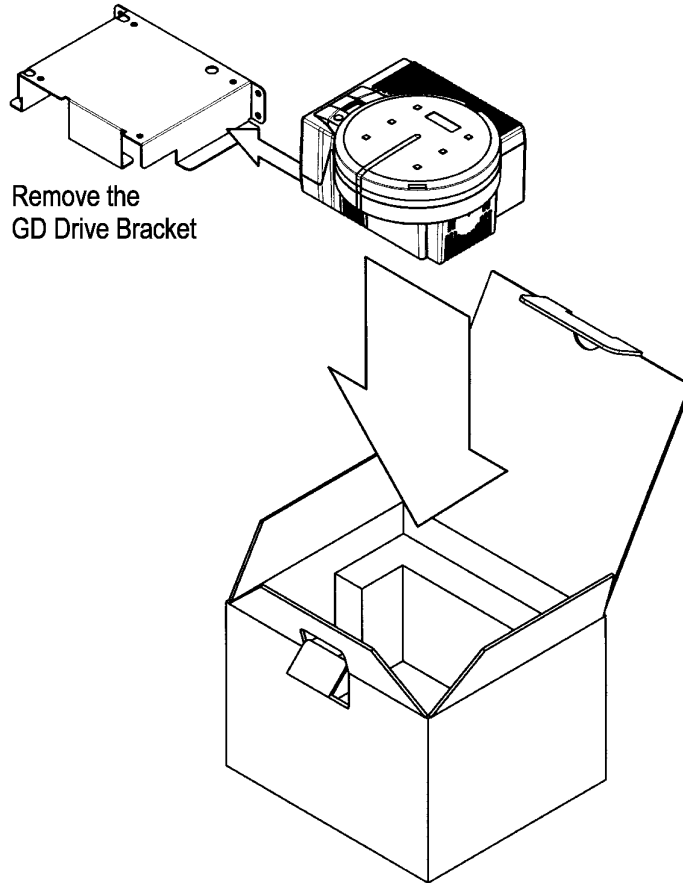

Remove the
GD Drive Bracket

3.8. ASSEMBLY INSTRUCTIONS



- Perform the assembly by following the procedure herein stated. Failure to comply with the instructions, for example, inserting the plug into an outlet at a stage not mentioned in this manual can cause an electric shock
- Assembling should be performed as per this manual. Since this is a complex machine, erroneous assembling can cause damage to the machine, or malfunction to occur.
- Do not attempt to complete this work alone, a minimum of 2 people are required.



- Only QUALIFIED SERVICE PERSONNEL should carry out assembly.

When carrying out the assembly work, follow the procedure in the following sequence:

STEP 1: ASSEMBLE THE MACHINE

STEP 2: LEG-LEVELLING PROCEDURE

STEP 3: COIN HANDLING INSTALLATION.

STEP 4: CONNECTION TO THE POWER SUPPLY

STEP 5: ASSEMBLY CHECK

Note that the parts contained within the installation kit are required for the assembly work.



- Fit all fixings loosely first as detailed in step 1, then position all components before finally tightening fixings at step 4.

3.8.1. ASSEMBLE THE MACHINE

3.8.1.1. ASSEMBLE THE PTV

1. Place the PTV and PTV Cabinet in roughly their final position, in close enough proximity to make the connections shown.

It is imperative that the earth eyes are connected to the plate at the bottom of the PTV.

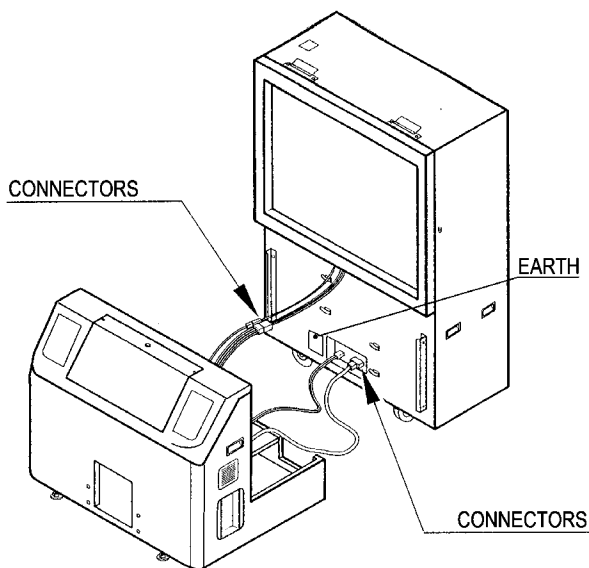

2. Lift the PTV forwards onto the PTV Cabinet, using a minimum of four workers to lift the PTV, plus a further worker to steady the PTV Cabinet. Use care during this exercise, as the PTV weighs in excess of 100kg.
3. Ensure the PTV is correctly seated on the PTV Cabinet.

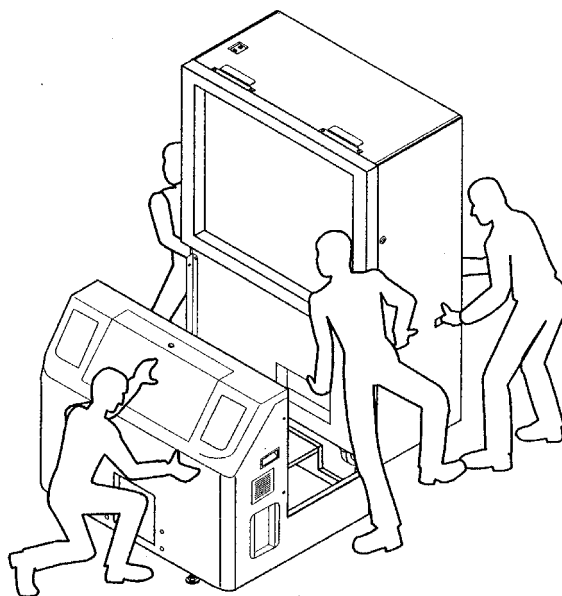

(Actual machine may differ slightly from the illustration)

3.8.1.2. ATTACH THE GUARD RAILS

1. Remove the guardrails from their packaging.
2. Fit the rails to the gun cabinet as shown using the M8 bolts and the M4 screws provided.

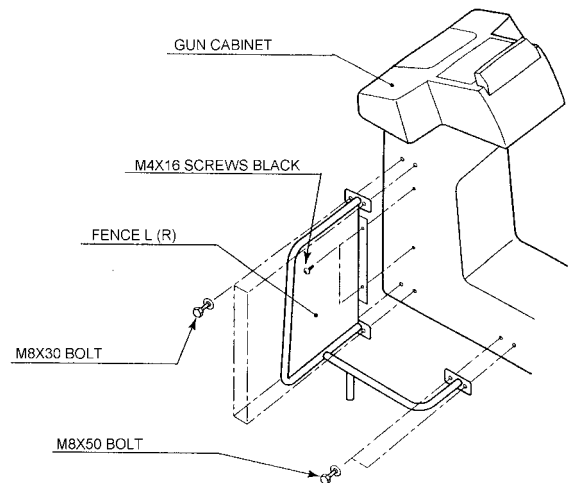

3.8.1.3. ATTACH GUN PANELS TO GUN CABINET

1. Take off from plates via 4 off M4 X 16mm security screws.

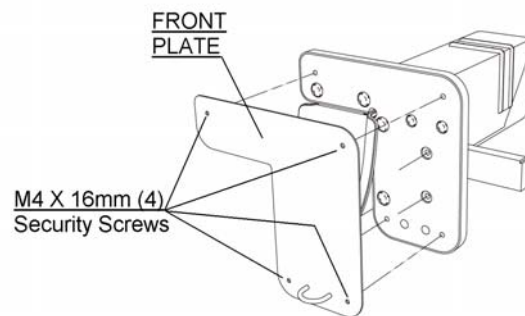

2. Remove the uppermost M6 Bolts either side of the coin tower.

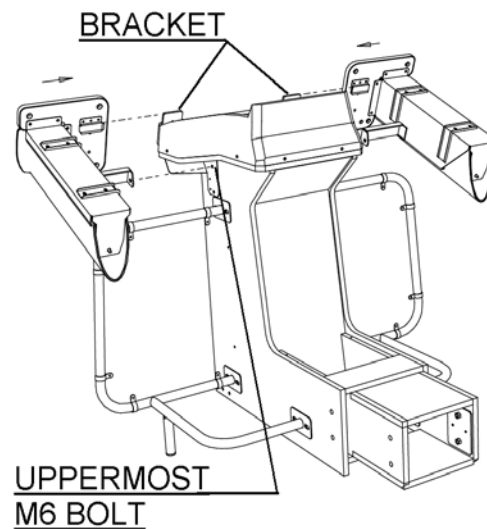

- Secure Gun HOLSTERS to Bracket using (4) M6 x 25 Socket Head Countersink Black Bolts (Pt No.029-F00625-0B) [2 per Assy]

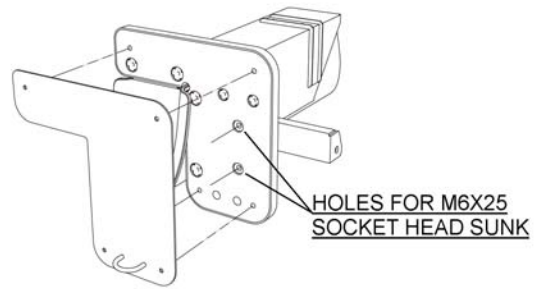

- Refit all removed components / fixings

3.8.1.4. ATTACH THE GUN CABINET

- After fitting the guard rails to the gun cabinet fit the gun cabinet to the main cabinet.
- Slide the gun cabinet into the hole in the main cabinet as shown.
- Fix the gun cabinet in position using the joint brackets and M8 bolts provided.

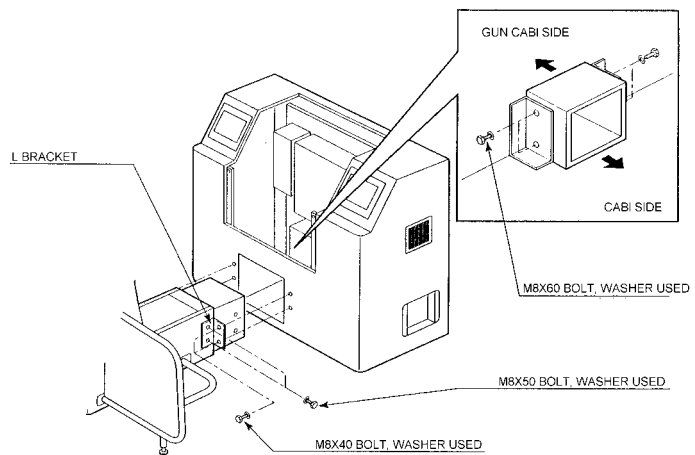

- Once the cabinet is secure connect the connectors as shown.
- Fit the cover in place using the M4x30 screws provided.

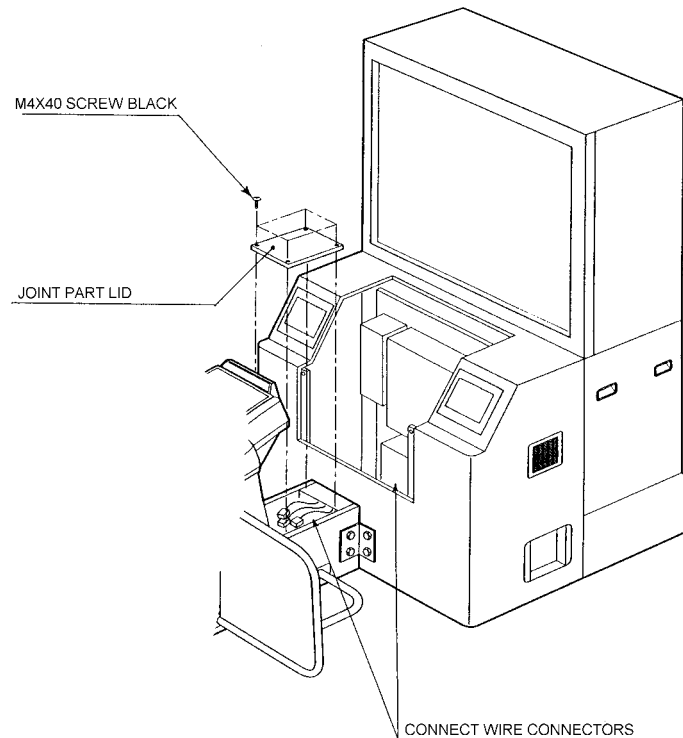

3.8.1.5. FIT THE BILLBOARD TO THE PTV

1. Fix the billboard to the PTV as shown.
2. Be sure to fit the connector from the billboard to the PTV. **It is imperative that the earth eye is connected to the top plate of the PTV.**
3. Place the billboard onto the PTV and slide it forward under the catches
4. Fix the billboard in position using the 2 off M5x16 screws provided

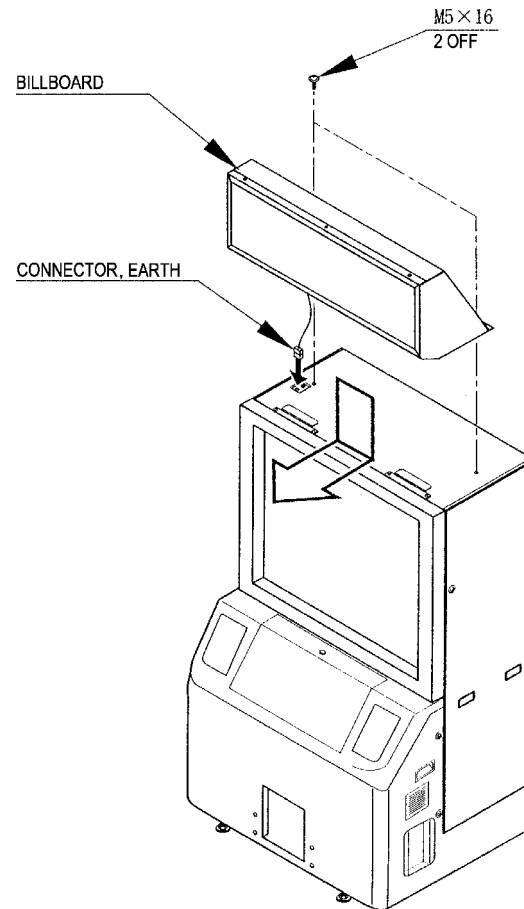
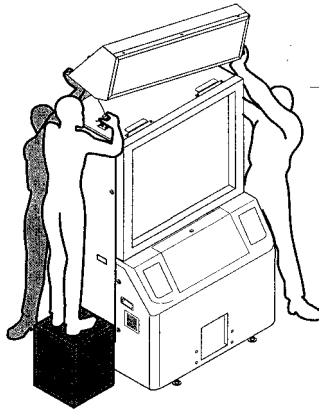

When fitting the Billboard, be sure to use three people for safety.

3.8.2. LEG-LEVELLING PROCEDURE



- This operation requires 2 people. Ensure that all leg adjusters are in contact with the floor otherwise the machine may move and cause injury.
- Only QUALIFIED SERVICE PERSONNEL should carry out this operation.

This machine has 4 castors and 8 leg adjusters. When the installation position is decided, unscrew the leg adjusters so that they raise each castor a minimum of 5mm from the floor. Make sure the machine is level.

1. Move the machine to its final position.
2. Adjust the leg adjusters as shown until the castors are approximately 5mm off the floor and the machine is level.

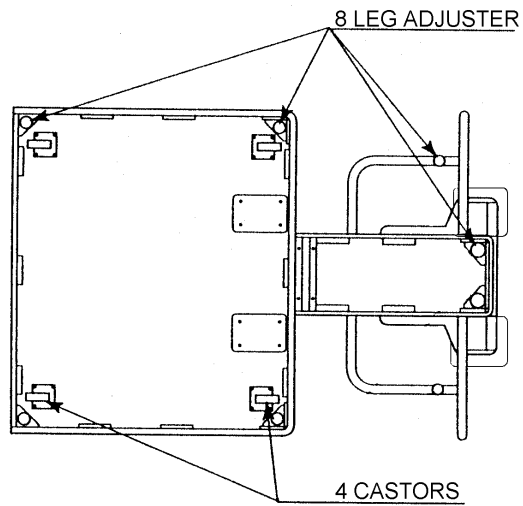
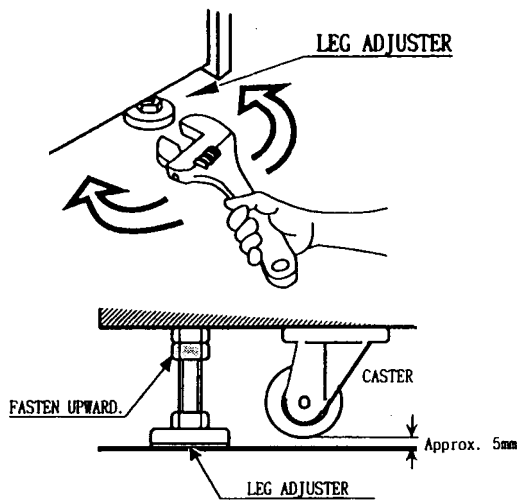

Ensure adequate ventilation is maintained as detailed below

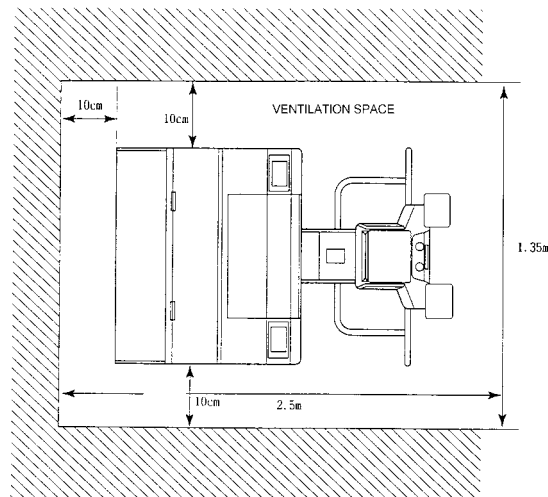

3.8.3. COIN HANDLING INSTALLATION.



- Only QUALIFIED SERVICE PERSONNEL should carry out this operation.

When fitting the coin mechanism to the door please refer to the specific manufacturers installation instructions for that coin mechanism. To fit the door to the machine, follow the procedure below.

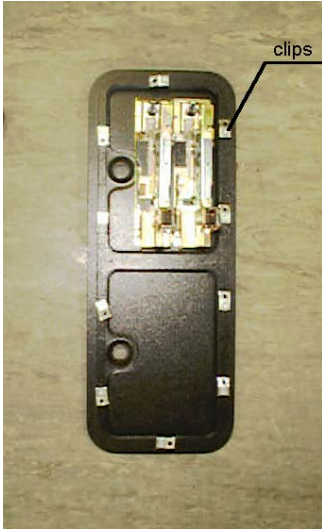

- Loosen all of the bolts on the frame that secure the clips.
- Turn all clips in towards the door.



- Position the door into the aperture in the machine.
- Turn the clips around so that they will hold the door in the machine.
- Tighten all of the bolts.

3.8.3.1.WIRING CONNECTIONS.

| COIN MECH | LOOM | INSTALLATION |
|----------------------------|--------------------------------|--|
| C220B | LM1006IDC LM1006LAMP-0.1 | <ul style="list-style-type: none"> • Attach the lamp holder to the bracket on the coin return button. • Attach one 15-way connector to the C220 coin mech. • Attach the other 15-way connector to Validator A on the credit board. • Attach the 2-way connector to 'LAMP' on the VTS board. |
| GENERIC MECHANICALS | LM1008 LM1008-LAMP | <ul style="list-style-type: none"> • Fit the two lamp holders behind the coin return buttons. • Attach the blue cable and orange cable to one mech's microswitch switch. • Attach the blue/green cable and orange/green cable to the other mech's microswitch. • Attach the 2-way mate and lok plug to the 2-way mate and lok cap provided. • Attach one 15-way connector to Validator A and the other to Validator B on the credit board |
| MARS MS111B1 MARS ME115 | LM1007 LM1008-LAMP | <ul style="list-style-type: none"> • Fit the lamp holder to the bracket behind the coin return button. • Fit one of the 13-way connectors to the coin mech. • Fit the other 13-way connector to Validator A on the credit board. Note the 13-way connector is keyed and this key must coincide with the key on the credit board. |
| SECI, C120, SR3 | OWN LOOM AND LM1006LAMP-0.1 | <ul style="list-style-type: none"> • Attach the lamp holder to the bracket on the coin return button. • Attach the 2- connector to 'LAMP' on the VTS board. • Attach the validator's own loom to position A on the credit board |

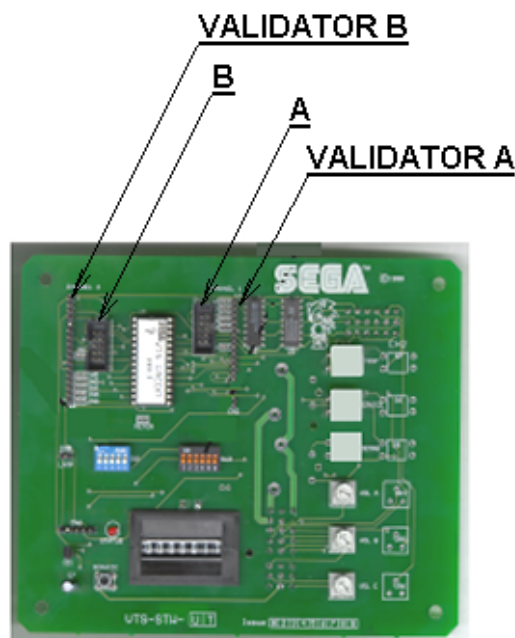

VTS credit board assembly

3.8.4. CONNECTION TO THE POWER SUPPLY



- This operation may only be carried out once the machine has been completely assembled.

- Only QUALIFIED SERVICE PERSONNEL should carry out this operation.

Once the machine has been fully assembled and fixed in position it is ready to be connected to the power supply

1. The socket outlet shall be installed near the equipment and shall be easily accessible.
2. Insert the IEC plug into the IEC socket on the cabinet.
3. Insert the mains cord into the wall outlet
4. Switch on the power at the wall outlet.
5. Switch on the mains switch on the AC unit of the machine.

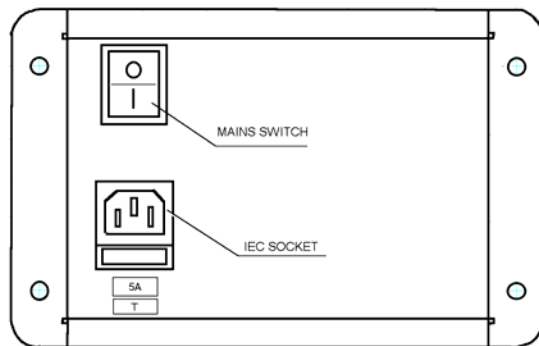

3.8.5. ADJACENT CONTROL INTERFERENCE PREVENTION



- Be sure that the machine is not connected to the mains supply before attempting this operation.
 - Be careful not to damage wiring.
 - The Game Board area should be accessed only if necessary.
-
- Only QUALIFIED SERVICE PERSONNEL should carry out this operation

When games with the same or similar infrared sensing system are installed side by side, interference may occur causing malfunction or inaccuracy of the sensing system in adjacent games.

A removable wire harness controls the operating frequency of the gun sense system. Removal of this harness switches from the default frequency to an alternate one.

Where game machines of the same or similar type are installed side by side, remove the jumper harness (SPY-60010UK) from every other machine in the line.

1. Turn off the power.
2. Remove the Game Board as detailed in section 3.13 of the Service Manual (the work can be completed with the Game Board in place but access is limited).
3. Locate the Sensor Board and remove SPY-60010UK WIRE HARNESS HIGH FREQUENCY JUMPER as required.

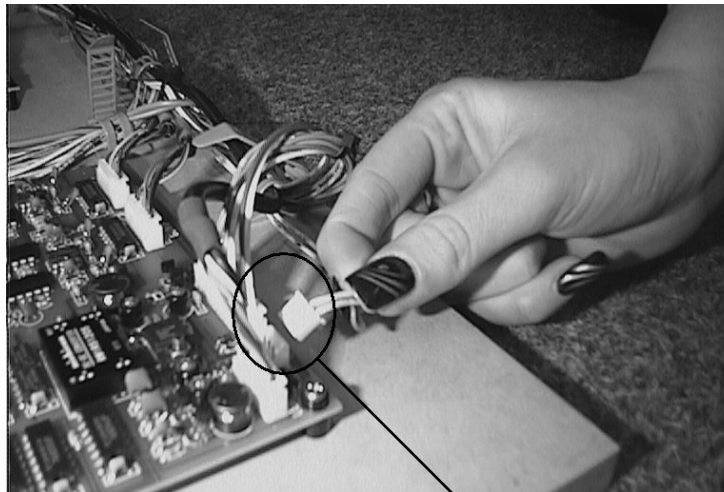

Disconnect

3.9. ASSEMBLY CHECK



- Only QUALIFIED SERVICE PERSONNEL should carry out this operation.

In the TEST MODE, ensure that the assembly has been made correctly and IC Board is satisfactory (refer to Section).

In the test mode, perform the following test:

3.9.1. MEMORY TEST

When "MEDIA BOARD TEST" is selected from the System Test Mode Menu Screen the Game Board memory is automatically tested. If the display beside each memory reads "GOOD", the Game Board is functioning correctly.

Also, when "SYSTEM INFORMATION" is selected, Main Board and Media Board data for the Game Board are displayed. If data is displayed correctly, the Game Board is functioning correctly.

```
MEDIA BOARD TEST

VERSION ****
STATUS GOOD
CHECKING 100%

SYSTEM TEST
DIMM0 - GOOD
DIMM1 - GOOD
IC34.35S - GOOD
IC10.11S - GOOD
GD DRIVE - GOOD
-- COMPLETED --

PRESS TEST BUTTON TO EXIT
```

MEDIA BOARD TEST screen

```
SYSTEM INFORMATION

MAIN BOARD
REGION ****
BOOT VERSION ****
QC FIRM VERSION ****
SC FIRM VERSION ****
SERIAL NO. *****

MEDIA BOARD
DIMM BOARD + GDROM
MEMORY SIZE 512MB
FIRM VERSION ****
SERIAL NO. *****

PRESS TEST BUTTON TO EXIT
```

SYSTEM INFORMATION screen

3.9.2. C.R.T. TEST

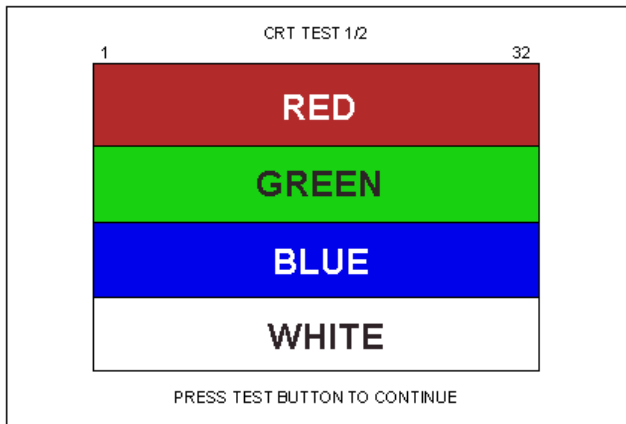

In the TEST mode menu, selecting C.R.T. TEST allows the screen (on which the monitor is tested) to be displayed. Although the monitor adjustments have been made at the time of shipment from the factory, make judgment as to whether an adjustment is needed by watching the test mode screen. If it is necessary, adjust the monitor by referring to Monitor manual.

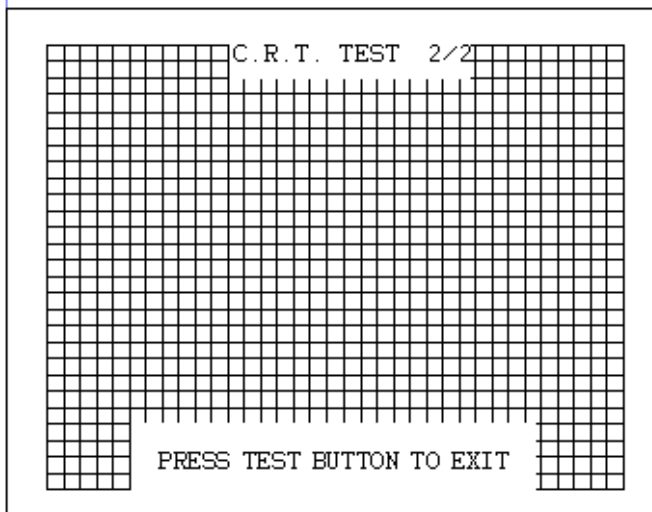

3.9.3. INPUT TEST

| INPUT TEST | | |
|------------|---------|---------|
| | PLAYER1 | PLAYER2 |
| START | OFF | OFF |
| TRIGGER | OFF | OFF |
| GRIP | OFF | OFF |
| GUN-X | 00 | 00 |
| GUN-Y | 00 | 00 |
| SCREEN-IN | OUT | OUT |
| SERVICE | OFF | |
| TEST | OFF | |

PRESS TEST AND SERVICE BUTTON TO EXIT

Selecting the INPUT TEST on the game test mode menu screen causes the screen (on which each switch is tested) to be displayed. Press each switch. If the display beside each switch indicates "ON," the switch and wiring connections are satisfactory.

3.9.4. OUTPUT TEST

Select OUTPUT TEST from the menu in the test mode to cause the screen (on which each lamp and wiring connections are tested) to appear. Ensure that lamp light up satisfactorily.

| OUTPUT TEST | | |
|-------------|--|-----|
| START1 LAMP | | OFF |
| START2 LAMP | | OFF |

-> EXIT

SELECT WITH SERVICE BUTTON
AND PRESS TEST BUTTON

3.9.5. GUN ADJUSTMENT

Before starting the operation, play the game by yourself and make sure that the gun readjustment is not needed and that you can play the game without a problem. Although completed at the factory, the gun adjustment may be necessary because after the adjustment the product has been disassembled for packing and shipping.

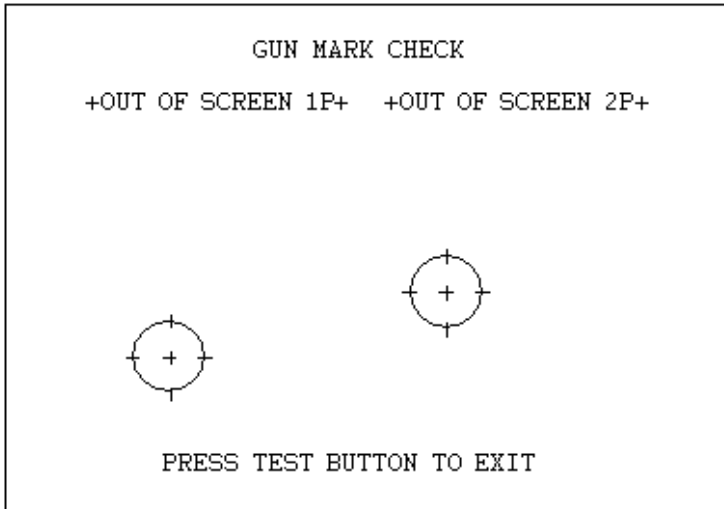

Perform the above inspections also at the time of monthly inspection.
As for the gun adjustment described in above, confirm weekly that the gun is properly adjusted.

3.10. MOVING THE MACHINE



CAUTION

- When moving the machine, be sure to remove the plug from the power supply. Moving the machine with the plug inserted can cause the power cord to be damaged, resulting in a fire or electric shock.
- When moving the machine, retract the leg adjusters fully and ensure the casters make contact with the floor. During movement pay careful attention so that the casters or leg adjusters do not damage any other cabling laid on the floor. Such damage could result in a fire or electric shock.



IMPORTANT

- Only QUALIFIED SERVICE PERSONNEL should carry out this operation.

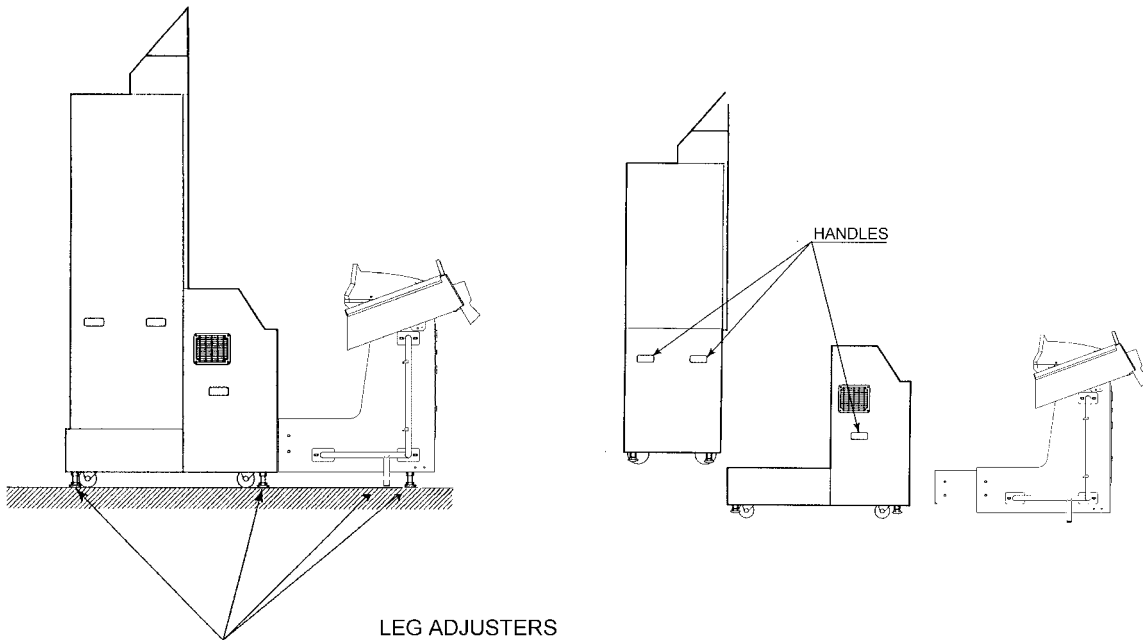

- Do not handle the machine by its plastic parts as this may result in damage or injury.

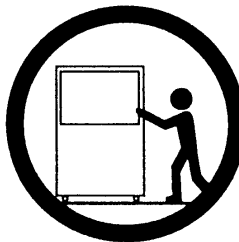

3.11. FUSES



- Never touch places other than those specified. Touching places other than those specified can cause electric shock and short circuit. Disconnect the machine from the supply before attempting the replacement of any fuse.



- Only QUALIFIED SERVICE PERSONNEL should replace FUSES.
- Only replace fuses with ones of the same value and type.

There are a number of fuses used on this machine to protect the user and the machine from damage. Only replace the fuse once you have removed the cause of its failure. Detailed below is a list of the fuses used, their location and if relevant PCB reference:

| PART NUMBER | LOCATION | TYPE & DETAILS | QTY PER COCKPIT |
|---------------|---------------------|--------------------|-----------------|
| 514-5078-6300 | 838-11856CE-02 (F1) | 5x20 HRC SB 6300mA | 1 |
| 514-5078-6300 | 838-13616 (F1) | 5x20 HRC SB 6300mA | 1 |
| 514-5078-5000 | IEC INLET (EP1302) | 5x20 HRC SB 5000mA | 1 |

There are also fuses located on the Monitor PCB. Refer to the relevant Monitor manual supplied to reference these fuses.

3.12. REPLACEMENT OF FLUORESCENT LAMP AND OTHER LAMPS



- Never touch places other than those specified. Touching places other than those specified can cause electric shock and short circuit. Disconnect the machine from the supply before attempting the replacement of any lamp.
- Use a step to perform work on the Billboard. Ensure the step is secure to avoid injury.
- The Fluorescent Lamp can get hot and cause burns. Allow the Lamp to cool before touching it.

- Only QUALIFIED SERVICE PERSONNEL should replace lamps.

3.12.1. FLUORESCENT LAMP REPLACEMENT

1. Remove Pop Panel (if fitted) and associated bracket by removing 3 x M4 Truss Screws.

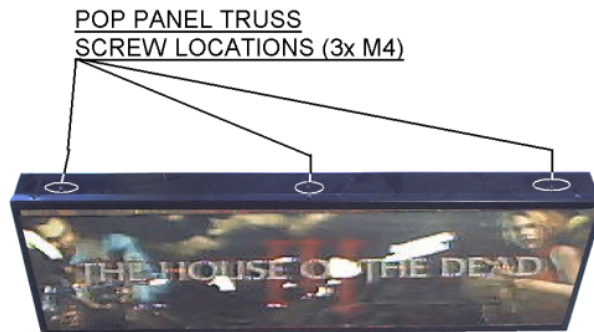

2. Remove the M4 Truss Screws to remove the Sash. Withdraw the Billboard Plate upwards.
3. To remove the Fluorescent Lamp, first remove both end connectors. Then withdraw the Lamp from the two clips, using care to avoid breakage.
4. Replacement of Lamp is in reverse order of removal.

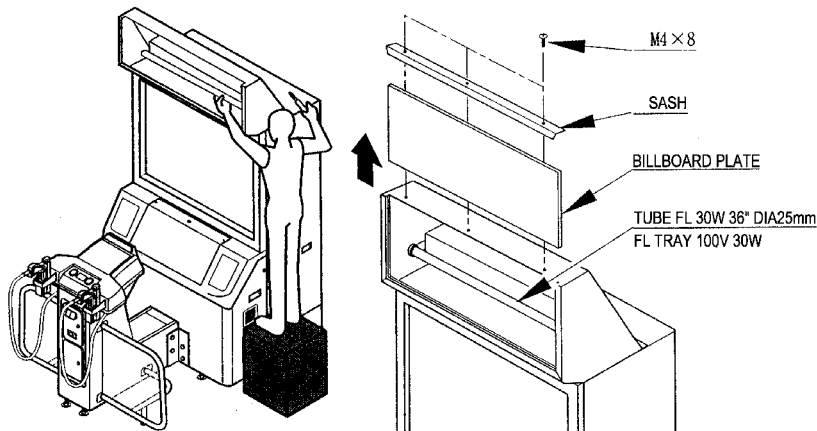

3.12.2.LAMP REPLACEMENT

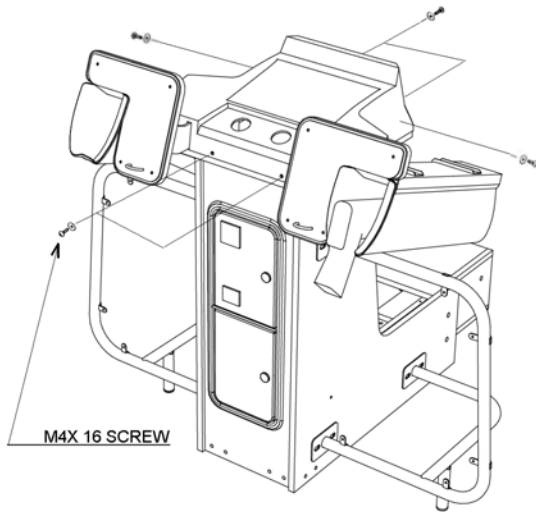

1. Remove the control panel cover as shown by removing the 8 screws holding it in position.
2. Carefully lift the control panel cover up until it is possible to disconnect the wire harness plugs attaching the start switches to the cabinet.
3. Turn the control panel cover over and remove the micro switch from the start switch as shown below.
4. Remove and replace the wedge lamp.
5. Reassemble the control panel cover to the gun cabinet.

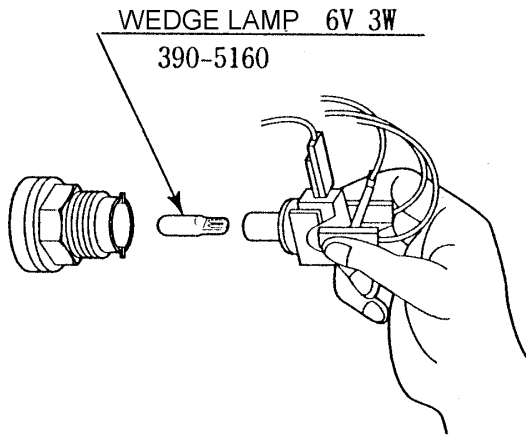

3.13. TROUBLESHOOTING



- Only QUALIFIED SERVICE PERSONNEL should carry out these procedures.

If a problem occurs, first check the wiring connections.

| PROBLEMS | CAUSE | COUNTERMEASURES |
|---|---|--|
| When the main switch is turned ON, the machine is not activated | The power is not ON. Incorrect power source/voltage. AC Unit CIRCUIT PROTECTION DEVICE (i.e. fuse) was activated due to an instantaneous overcurrent. | Firmly insert the plug into the outlet. Make sure that the power supply/voltage are correct. First, remove the cause of overcurrent and reinstate the circuit protection device to its original status. Then identify the cause of the fault on the item that caused the overcurrent & fix. |
| The colour image on the screen is incorrect | Incorrect monitor adjustment. | Make appropriate adjustments. SEE SECTION 3.9. |
| The on-screen image of the monitor sways and/or shrinks | The power source and voltage are not correct. | Make sure that the power supply and voltage are correct. |
| Sound is not emitted | Sound volume adjustment is not correct. Malfunctioning BD and Amp. Connector connection is incorrect | Adjust the volume setting on the VTS bracket. SEE SECTION 5.1.1 Perform Sound Test to check it. SEE SECTION 5.2.5 Check connector connection from Base to Speaker |
| Controller operation is not satisfactory | Sighting is inaccurate due to environmental conditions, etc. Micro-switch malfunctioning Sensor BD is malfunctioning | Adjust the gun sighting alignment. SEE SECTION 3.14 Replace the micro-switch. SEE SECTION 3.14 Replace the Sensor BD. SEE SECTION 3.14 |
| The fluorescent lamp does not light up | Fluorescent lamp needs replacement The connector is disconnected | Replace the fluorescent lamp. SEE SECTION 3.12 Check connector connections in the billboard case. |

3.14. CONTROLLER UNIT (SHOTGUN)



- Only QUALIFIED SERVICE PERSONNEL should carry out these procedures.



- In order to prevent an electric shock and short circuit, be sure to turn power off before performing work by touching the interior parts of the product.
- Be careful not to damage the wires. Damaged wires may cause electric shock or short circuit or present a fire risk.
- Be very careful when soldering. Handling a soldering iron carelessly may result in a fire or a burn.
- When securing the plastic-made parts, do not excessively fasten screws and nuts. Failure to observe this may damage the parts and cause injury due to fragments resulting from damage.



- Do not cut the tie belt securing the wires in the Control Unit (Shotgun). Cutting the tie belt may cause malfunctioning of the wire connection. If you cut the tie belt when replacing the wire etc., be sure to secure the wires using a new tie belt as before
- After removing 4 bind screws once, retighten them by using the designated threadlocking agent (Part Number: 090-0012). If the threadlocking agent is not used, the reassembled shotgun may rattle or come apart.
- Use only the threadlocker designated in this manual. Use of other threadlocking agents may cause chemical reactions that could damage the screws or part's surface.

In the cases where the gun's operation is not satisfactory or the gun sight deviates from the direction in which the control unit is pointed, the gun's interior parts may have been damaged. Replace the parts by disassembling the gun in the following procedure: Also, be sure to perform sighting check in the test mode when the gun parts are replaced.

REPLACING THE MICROSWITCH

To replace parts in the Shotgun, it is necessary to separate the two halves of the outer case cover. Internal parts are inserted directly into the right side of the cover, so the procedure should be carried out with the right half downmost.

1. Turn the power OFF.
2. Remove the 2 BIND screws from each side and remove the left and right Slide Grips.
3. To separate the left and right halves of the cover, remove the 3 (M3X8) screws and the 12 (M3X16) screws. Be aware that 1 (M3X16) screw is in the right side of the cover. Therefore, remove the 1 screw on the right half of the cover first, before removing the rest of the screws, with the right half downmost.
4. With the right half downmost, remove the left half.
5. Pull the trigger side microswitch out of the right cover.
6. Remove the solder and remove the microswitch.
7. The pump action side microswitch is contained in the slide mechanism. Pull the slide mechanism out from the right cover.

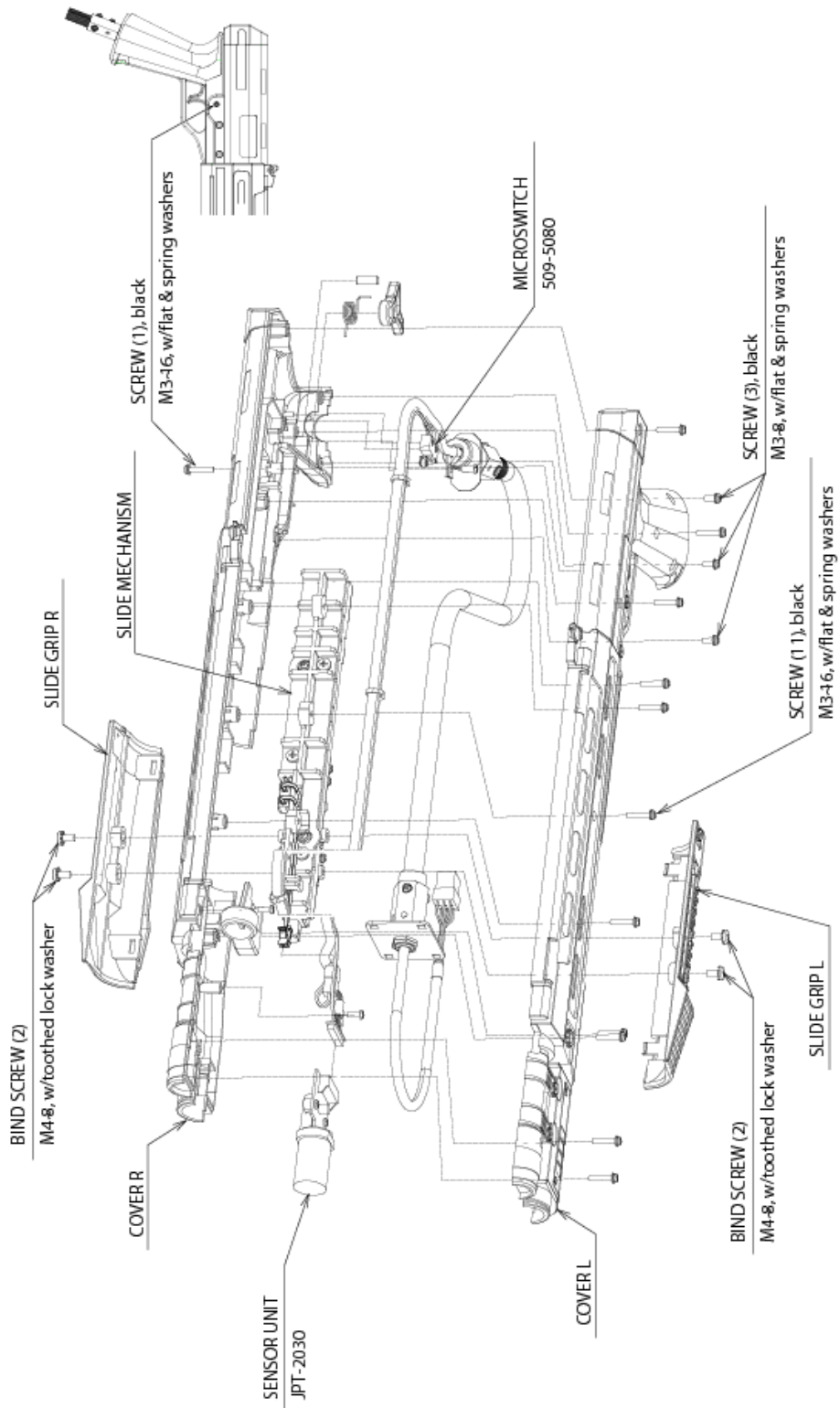

8. Remove the 2 tapping screws, and remove the microswitch from the slide mechanism.
9. Remove the solder and remove the microswitch.

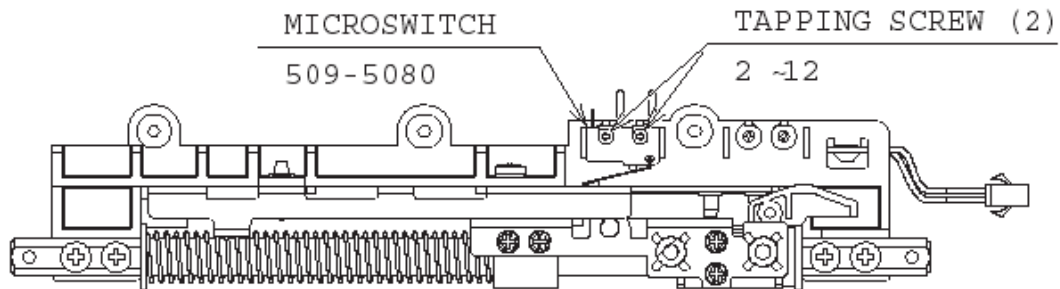

SLIDE MACHANISM

1. Solder in the new microswitch, and assemble the Shotgun. When assembling, be careful not to over-tighten the screws. Be especially careful when tightening the tapping screws.
2. Operate the trigger and grip, and make sure that the microswitch turns ON/OFF correctly.

REPLACING THE SENSOR UNIT

Follow instructions 1. through 4. of "Replacing the Microswitch" up to removing the left side cover.

1. Disconnect the connector and remove the Sensor Unit.
2. Remove the tapping screw, if required to gain better access.

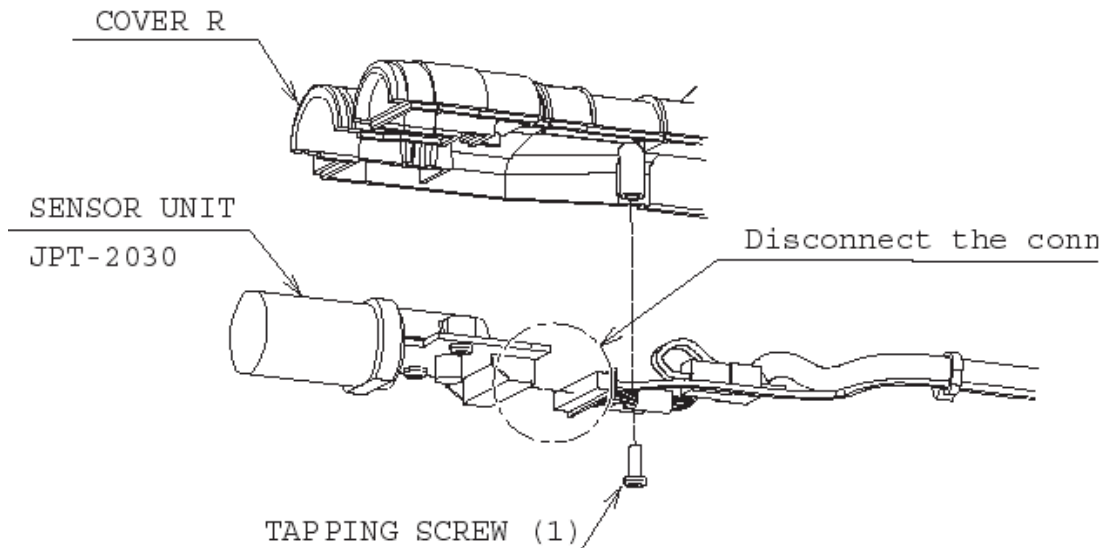

3.15. GAMEBOARD



- Turn off the mains power and remove the power cord before opening the machine.
- To prevent risk of shock or fire, be careful not to damage any wiring.

- The GAME BOARD should not require any work to be carried out upon it. All settings and tests can be achieved without access to the GAME BOARD.
- Take anti-static precautions to avoid damaging the electronic parts.
- All work to be carried out by QUALIFIED SERVICE PERSONNEL

The GD-ROM Service Manual supplied with this product instructs you to remove the Key Chip when shipping the CHIHRO Board. However, this product employs a dedicated CHIHRO Board, therefore do not disassemble the CHIHRO Board or remove the Key Chip.

3.15.1.REMOVING THE BOARD

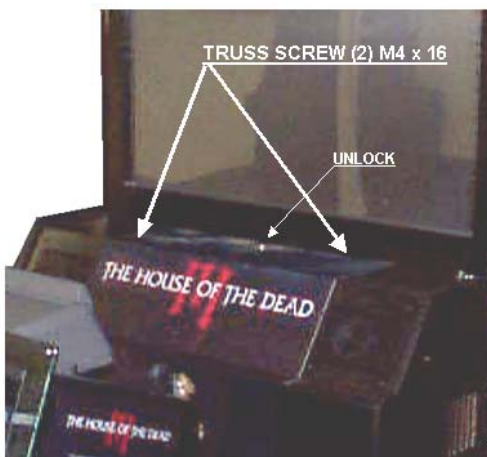

1. Turn off the power.
2. Remove the two screws and unlock the LID UPPER.

3. Disconnect all harnesses connected to the CHIHRO Main Board assembly as circled below.

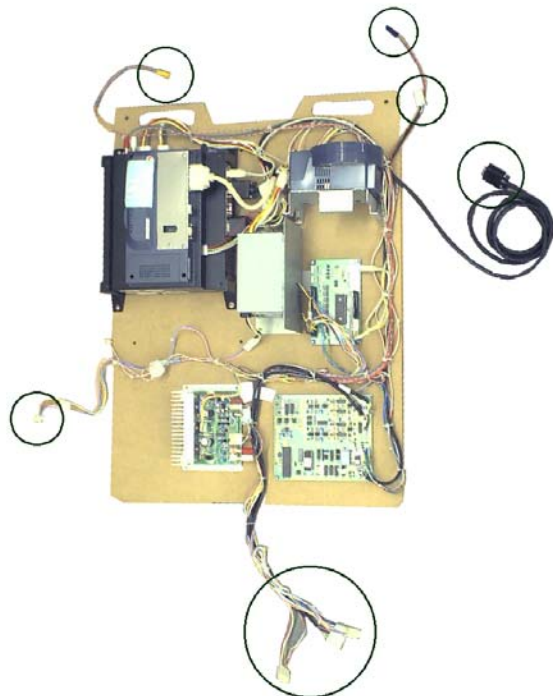

4. Remove the two screws securing the base to the cabinet and withdraw the main board assembly upwards out of the cabinet. using the 2 hand holds in the board.

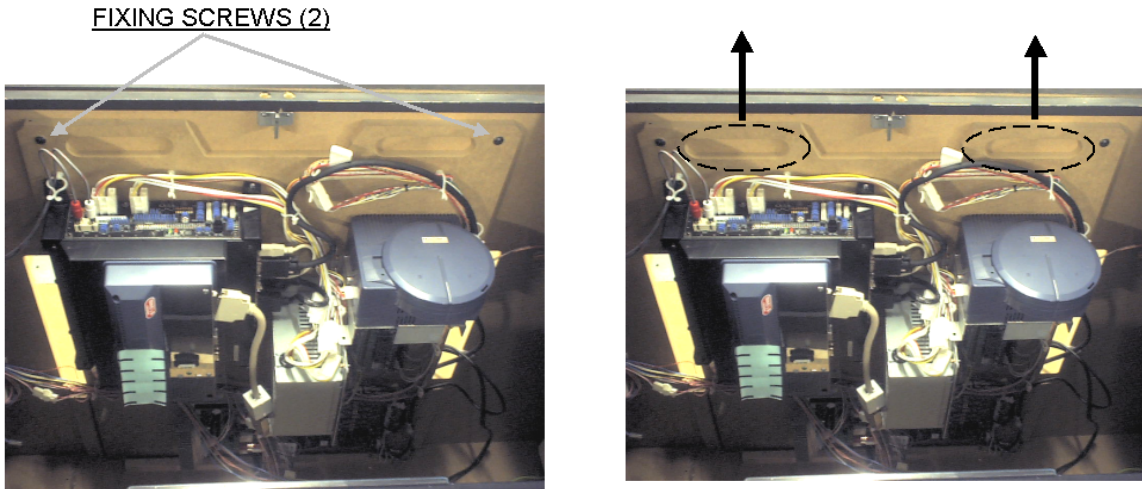

5. Pull the ASSY MAIN BD out of the Cabinet and set it on a level surface before continuing.
6. Unplug all connectors connected to the Chihiro Board.
7. Unplug the GD Cable connector on the side of the Media Board on the Chihiro Board.
8. Unplug the AVIP Cable connected to the Chihiro Board. This is because the AVIP Cable is packed with it when the Chihiro Board is transported.
9. Remove the 4 screws and remove the Chihiro Board from the Base.

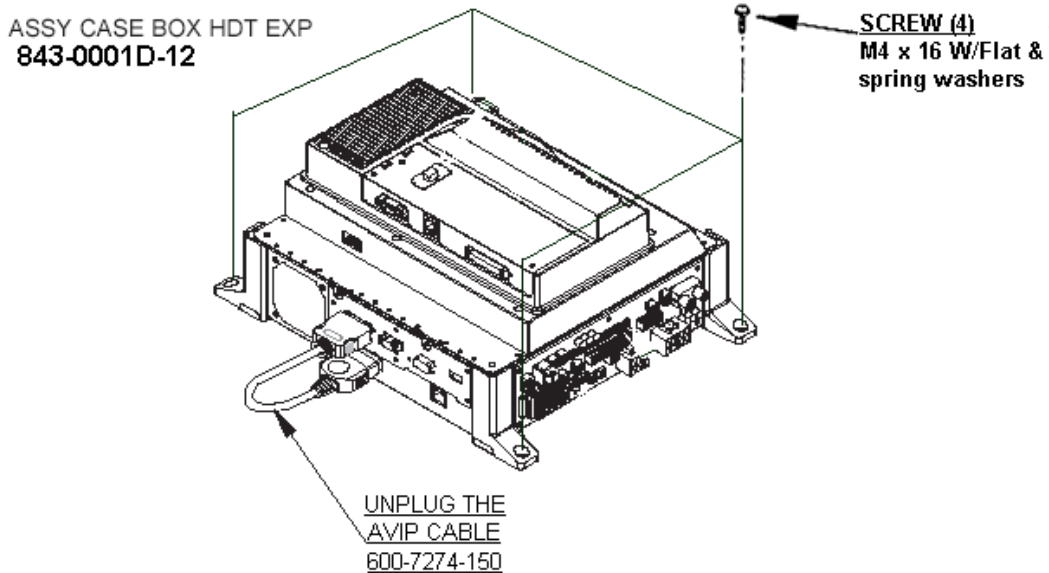

3.15.2.REMOVING THE GD-ROM DRIVE

Take out the ASSY MAIN BD from the PTV cabinet and remove the GD-ROM Drive from the ASSY MAIN BD as follows:

- i. Following the above procedure (steps 1 to 5), take out the ASSY MAIN BD.
2. Remove the GD cable connector and the power cord connector from the GD-ROM Drive.

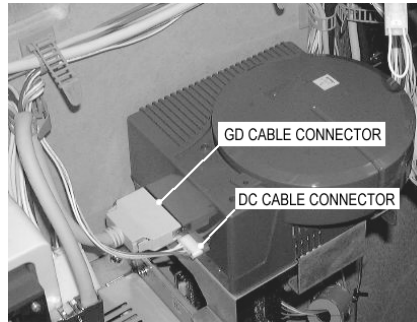

3. To remove the GD-ROM Drive, undo the four screws shown.

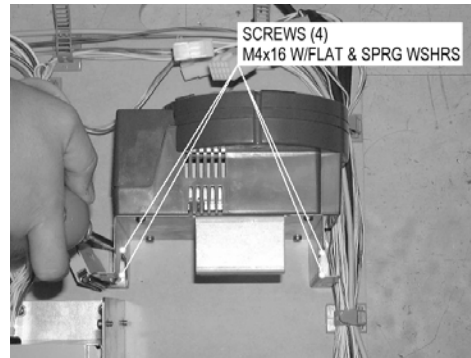

3.16. COMPOSITION OF THE GAME BOARD

ASSY CASE BOX HDT EXP
843-0001D-12

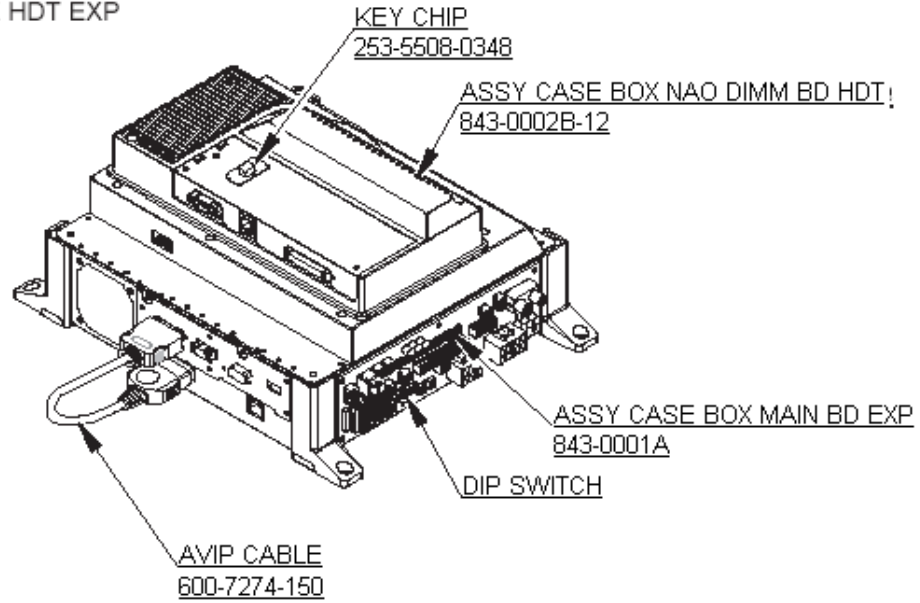

DIP SW SETTING

Use this product with the DIP SW settings shown in the figure below.



3.17. PERIODIC CHECK AND INSPECTION

The items listed below require periodic check and maintenance to retain the performance of the machine and ensure safe operation:



- Be sure to check annually to see if the power cords are damaged. The plug is securely inserted and that there is no dust in the interior of the machine or between the socket and the power cord. Using the product in an unclean condition may cause a fire or electric shock.

- Only QUALIFIED SERVICE PERSONNEL should carry out periodic checks.

| DESCRIPTION | WHAT TO CHECK | INTERVAL |
|---------------------|--------------------------------------|-------------|
| MONITOR / PROJECTOR | Clean screen | Weekly |
| | Check adjustment | Monthly |
| GAME BD | Memory Test | Monthly |
| | Game Assignments | Monthly |
| INTERIOR | Clean (Do Not use water jet) | Annually |
| POWER SUPPLY CORD | Check condition | Annually |
| CABINET SURFACE | Clean (Do Not use water jet) | As required |
| CONTROL PANEL | Lamp operation | Monthly |
| | Check switch operation | Monthly |
| CONTROLLER (GUN) | Clean | As required |
| | Check sighting | Weekly |
| | Check switch operation | Monthly |
| COIN MECHANISM | Check SW (If Fitted) | Monthly |

4. HOW TO PLAY

Use this section to confirm the machine is operating correctly; if the machine doesn't operate as described there may be a fault.

While power is connected, the billboard is continuously lit and demonstration footage and ranking data are displayed on the screen. This 'advertise' mode will be accompanied by sound from both speakers unless set otherwise in the TEST mode.

The 1P and 2P start buttons have integral lights that flash when a credit is inserted.



4.1. GAME CONTENTS

4.1.1. GAME OUTLINE

1. Insert a coin and the credit indicator below the screen will count up. When enough coins have been entered for one play, the "INSERT COIN(S)" message below the screen will change to "PRESS START BUTTON", and both START buttons will flash.
 2. A player plays on the left or the right by pressing the start button on that side.
 3. Pressing the start button begins the game.
 4. When the game starts, the stage title is displayed and a demo plays before switching over to game play.
- Life and loaded bullets remaining are shown at the bottom left of the screen for the player on the left (Player 1). Life and loaded bullets remaining are shown at the bottom right of the screen for the player on the right (Player 2).

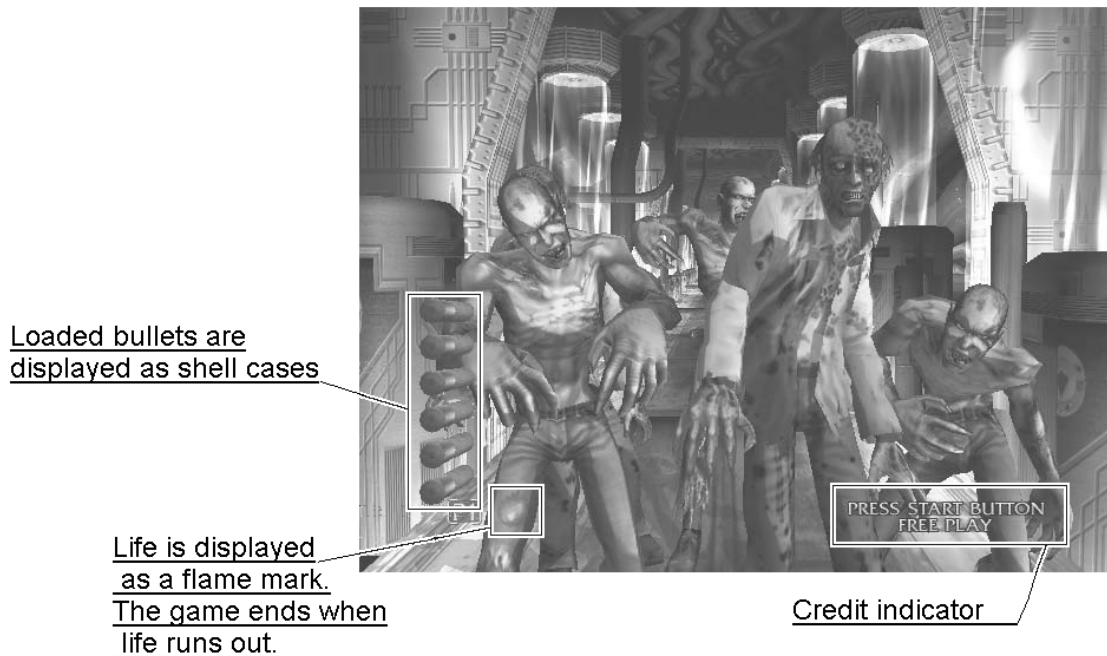

- Firing six rounds empties the weapon and displays the "RELOAD" instruction on the screen. Players load the shotgun clip by pump action. If some bullets remain, pumping the shotgun will fully reload the gun. Reloads with pump action!

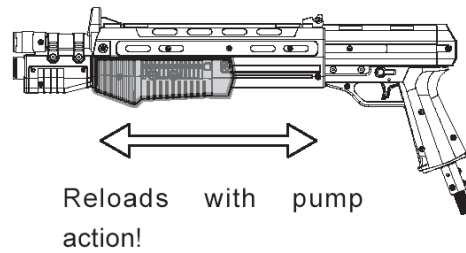

- Players can defend themselves against knives, oil drums and barrels thrown by enemies by shooting them.
- Shooting the background will sometimes cause items to appear. Players grab them by shooting them. Grabbing items will increase a player's score or restore life.
- When life reaches zero the game ends.

A unique boss awaits the players at each stage. The bosses appear different on each stage. Players defeat a boss by reducing its Life Meter to zero. In addition, when a boss begins to attack the Cancel Meter appears. Players can stop the boss's attack by reducing this meter to zero.

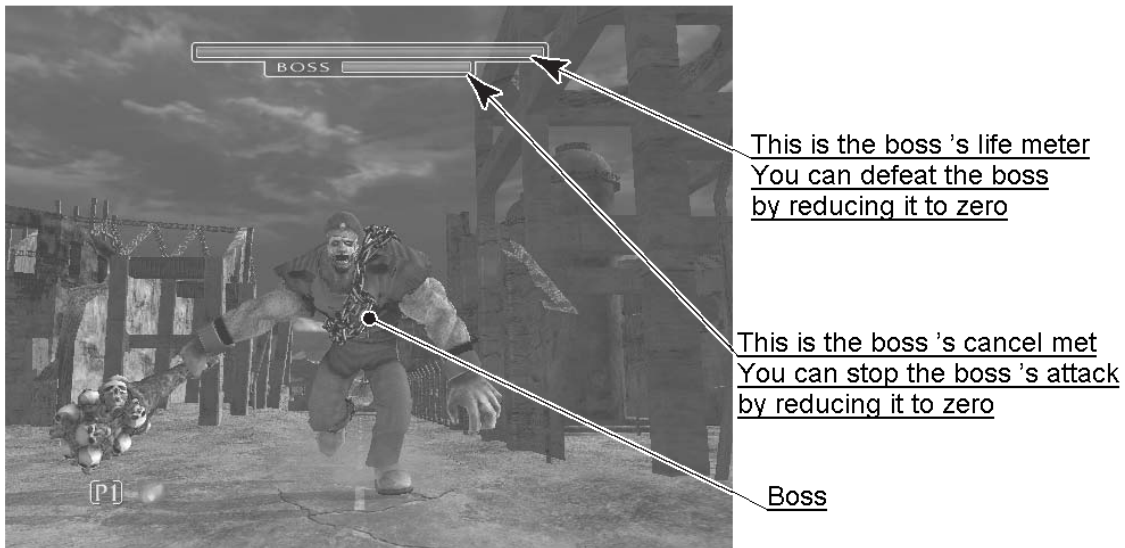

As players advance through the game, events will occur where enemies surround one player. The players' lives will increase if the other player succeeds in rescuing the surrounded player.



The players' lives will increase if they manage to drop the enemies

Surrounded player

A player can join a game in progress at any time by inserting coins and pressing the start button. In addition, the start button on the side where no one is playing will continue to flash if enough credits remain. A second player can join the game by pressing the flashing start button.

"CONTINUE" is displayed when life drops to zero. A player may continue by inserting sufficient coins and pressing the start button. When there are enough credits for another game, a player can continue by pressing the start button.

After completing the game, players can enter their names on the ranking display if their scores are among the top ten.

4.1.2. ITEMS



"Medical Kit"
Increases life by one.



"Mini magician"
Increases a player's score.



"Gold Coin"
Increases a player's score.

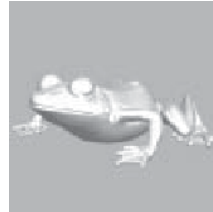

"Golden Frog"
Increases a player's score.



"Warped Coin"
Increases a player's score.



"MechaZombie"
Increases a player's score.



"Crystal Coin"
Continuously increases a player's score as it is shot.

4.1.3. PLAY HINTS

- * **Aim for the head!**
On any stage, the weak point of enemy characters other than the boss is the head. Shooting the head will significantly decrease the enemy's life. The shotgun pellets spray out in a wide range, so players can cause more damage and drop an enemy more quickly by aiming at its head.
- * **Choose your favourite route!**
The routes in stages (Stage 1, Stage 2, Stage 3, Stage 4) branch according to the players' choices. Players should find their own best routes as a way to improve their play.
- * **When life is low, restore it through life-increasing events!**
A player's life decreases when attacked by an enemy, but numerous life-increasing events are provided throughout the stages. The life-increasing events happen at set locations within each stage. Repeated play will help players take advantage of these events.

5. MAINTENANCE INSTRUCTIONS

5.1. EXPLANATION OF TEST AND DATA DISPLAY

Perform the tests and data check periodically when installing the machine initially or collecting cash, or when the machine does not function correctly. Perform checks in accordance with the explanations given in this section.

The following shows tests and modes that should be utilized as applicable. This product's basic system consists of the Chihiro game board and the GD-ROM drive. The system enables you to play several games one after the other just by changing a GD-ROM disc that is to be set on the GD-ROM drive.

Therefore the product supports, the following 2 test modes:

(1) System test mode for an automatic self-diagnostic test (generally used by every product that contains the basic system) and a coin assignment (specifically used by this product)

and

(2) Game test mode for testing the input/output control devices and setting the difficulty level (specifically used by this product).

| | |
|--|---|
|  <p>STOP IMPORTANT</p> | <ul style="list-style-type: none">• Any settings that are changed by users during TEST MODE are saved upon exiting TEST MODE with the EXIT command in the SYSTEM MENU. If the unit is powered off prior to exiting, changes to settings will not take effect.• You may not enter GAME TEST MODE while the unit is reading from or checking the GD-ROM. If error messages are displayed when exiting TEST MODE, you should power the unit off and on again.• In the manual for this product, "Media Board" and "DIMM" are one and the same.• Use with the specified settings. If settings other than those specified are used, inappropriate operations or malfunction may occur. |
|--|---|

| ITEM | DESCRIPTION / REFERENCES | INTERVAL |
|-----------------------------|--|-----------------------|
| INSTALLATION OF THE MACHINE | When the machine is installed perform the following checks: <ul style="list-style-type: none"> • Check to see that each setting is as per the standard settings input at the time of shipment. 3.9 • In the INPUT TEST mode, check each switch. 5.3.1 • In the OUTPUT TEST mode, check each of the lamps. 5.3.2 • Test on-IC-Board IC's in the self-test mode. 5.2.1 | Monthly |
| MEMORY | <ul style="list-style-type: none"> • This test is automatically executed by selecting RAM TEST, or ROM BOARD TEST in the Menu mode. 5.2 | Monthly |
| PERIODIC CHECKS | Periodically perform the following <ul style="list-style-type: none"> • MEMORY TEST. 5.2 • Ascertain each setting. • In the INPUT TEST mode, test the control devices. 5.3.1 • In the OUTPUT TEST mode, check each of the lamps. 5.3.2 | Monthly |
| CONTROL SYSTEM | <ul style="list-style-type: none"> • In the INPUT TEST mode, check each switch and • Adjust or replace each switch and | Monthly |
| MONITOR (Projector) | <ul style="list-style-type: none"> • In the CRT TEST mode, check to ensure the monitor (projector) is adjusted correctly. 5.2.6 • Clean screen - (switch off machine and remove the plug). Do not use a water jet. | Monthly Weekly |
| IC BOARD | MEMORY TEST 5.2 <ul style="list-style-type: none"> • In the SOUND TEST mode, check the sound related ROMs. 5.2.5 | Monthly |
| DATA CHECK | <ul style="list-style-type: none"> • Check such data as held in the bookkeeping screens, relating to number and length of plays. 5.2 & 5.3.5 | Monthly |
| EXTERIOR MAINTENANCE | <ul style="list-style-type: none"> • Clean surfaces | Monthly |
| COIN MECHANISM | <ul style="list-style-type: none"> • Check switch operation (if fitted) | Monthly |

5.1.1. VTS ASSEMBLY



- Do not touch places other than those specified. Touching places not specified could cause an electric shock or short circuit.

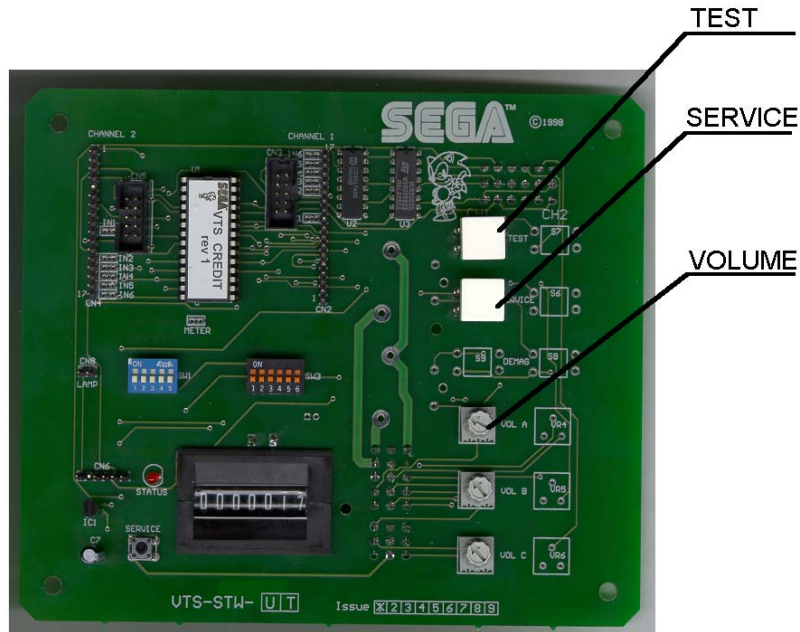

Opening the Coin Chute door will reveal the VTS Assembly shown above. The function of each switch is as follows.

TEST BUTTON
(TEST SW)

Used to enter TEST mode. Also has function during TEST mode. Refer to the later section detailing TEST mode.

SERVICE BUTTON
(SERVICE SW)

Gives credits without registering on the coin counter. Also used during TEST mode.

DEMAG

Eliminates colour unevenness from the monitor screen.

VOLUME CONTROL FRONT

Adjusts the volume of the sound emitted from the speakers.

The control panel switches can also be used in the place of the VTS switches:

Note: There are three volume controls on the VTS, only the top volume control is used, the other two are spares.

5.2. SYSTEM TEST MENU MODE

System Test Mode can be used to check that the main circuit operations are correct, adjust Monitor colour, and perform coin/credit settings.

However, this product can only be used with the settings shown below.

SOUND TEST - OUTPUT TYPE: STEREO
COIN ASSIGNMENTS - COIN CHUTE TYPE: COMMON
- SERVICE TYPE: COMMON
NETWORK SETTING (MEDIA) - NETWORK TYPE: NONE

1. Press the TEST Button after powering on the unit to display the following SYSTEM MENU.

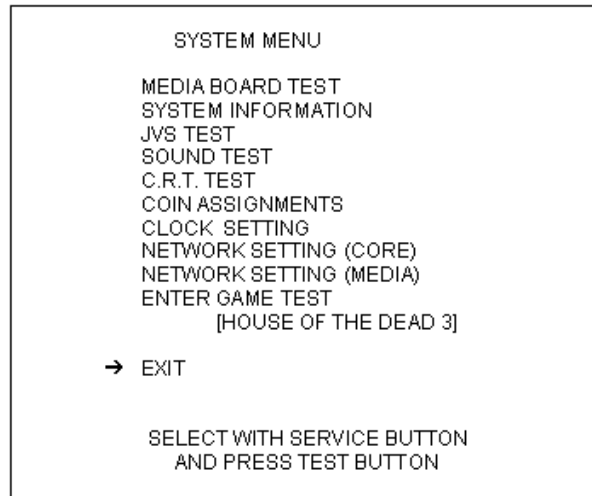

2. Press the SERVICE Button to move the cursor to the desired test item.
3. Move the cursor to the desired item and press the TEST Button to display each test screen.
4. Move the cursor to ENTER GAME TEST and press the TEST Button to enter the individual test menus for each game. Refer to "9-3 GAME TEST MODE".
5. When testing is complete, move the cursor to EXIT and press the TEST Button. The game advertisement screen should be displayed.

5.2.1. MEDIA BOARD TEST

| | |
|---|---|
|  IMPORTANT | Powering off the system during the MEDIA BOARD TEST with a DIMM BOARD will erase the game programme data. It may be necessary to reload the data. Always wait for the test to complete before attempting to exit. |
|---|---|

MEDIA BOARD TEST is used to check the memory and IC on the MEDIA BOARD connected to the Chihiro. Test screens and test times may differ depending on the type of MEDIA BOARD connected to the unit.
*The following is the MEDIA BOARD TEST screen for a unit with a DIMM BOARD.

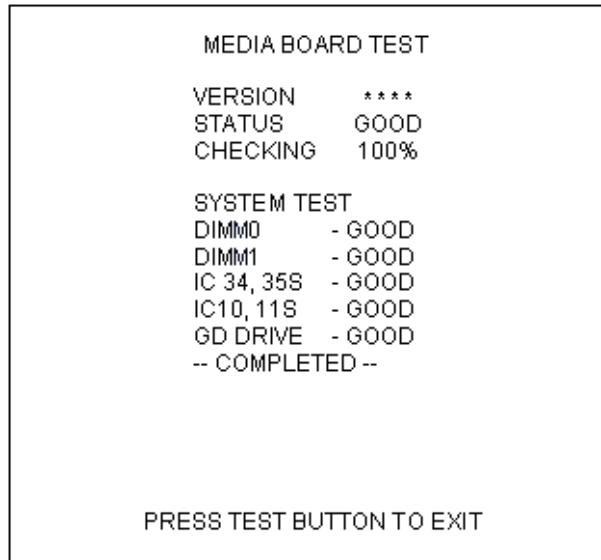

1. MEDIA BOARD TEST begins immediately upon entering this test mode.
2. If "GOOD" is displayed to the right of each item, the MEDIA BOARD components are functioning properly.
3. After the test is complete, move the cursor to EXIT and press the TEST Button to return to the SYSTEM MENU screen.

5.2.2. SYSTEM INFORMATION

Use SYSTEM INFORMATION to check version and other information for system programmes. Screens may differ depending on the type of MEDIA BOARD connected to the unit.

*The following is the SYSTEM INFORMATION screen for a unit with a DIMM BOARD.

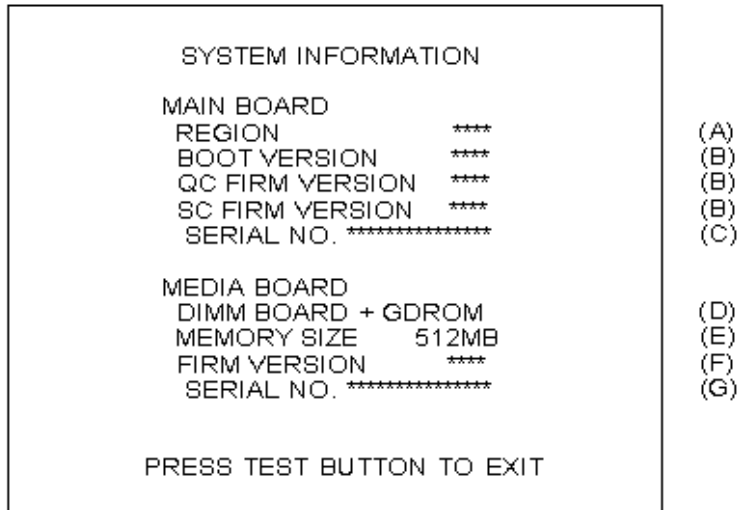

Press the TEST Button to return to the SYSTEM MENU screen.

- (A) REGION
The COUNTRY CODE of the MAIN BOARD.
- (B) BOOT VERSION, QC FIRM VERSION, SC FIRM VERSION
Version information for the MAIN BOARD system programmes.
- (C) SERIAL NO.
Serial number of the MAIN BOARD.
- (D) DIMM BOARD + GDROM
Type of MEDIA BOARD. This example shows a DIMM BOARD with a GD-ROM DRIVE connected.
- (E) MEMORY SIZE
Capacity of DIMM memory installed on the DIMM BOARD.
- (F) FIRM VERSION
Version information for the DIMM BOARD system programme.
- (G) SERIAL NO.
Serial number of the DIMM BOARD.

5.2.3. JVS TEST

JVS TEST is used to verify the specs of the I/O BOARD connected to the Chihiro and to run input tests. I/O BOARD specs are displayed initially. Screens may differ depending on the type of I/O BOARD connected to the unit.

```
JVS TEST
INPUT TEST
NEXT NODE
EXIT
NODE   →
NAME   *****
      I/O BD JVS
      VER *****
      *****
      CMD VER 1.1
      JVS VER 2.0
      COM VER 1.0
      SWTCH 2 PLAYER(S) 13 BITS
      COIN 2 SLOT
      ANALOG 8 CH
      ROTARY 0 CH
      KEYCODE 0
      SCREEN X:0 Y:0 CH:0
      CARD 0 SLOT
      HOPPER OUT 0 CH
      DRIVER OUT 6 CH
      ANALOG OUT 0 CH
      CHARACTER CHARA: 0 LINE: 0

      SELECT WITH SERVICE BUTTON
      AND PRESS TEST BUTTON
```

- (1) Use the SERVICE Button to move the cursor to the desired test item.
- (2) Move the cursor to INPUT TEST and press the TEST Button to enter the INPUT TEST screen for the I/O BOARD currently displayed.
- (3) When 2 or more I/O BOARDS are connected, move the cursor to NEXT NODE and press the TEST Button to enter the test screen for the next I/O BOARD. The lower the NODE number, the further away the node is from the Chihiro.
- (4) Move the cursor to EXIT and press the TEST Button to return to the SYSTEM MENU screen.

5.2.4. INPUT TEST Screen

| JVS TEST | | |
|------------|------|-----|
| INPUT TEST | | |
| NODE | 1/1 | |
| SYSTEM | 00 | (A) |
| PLAYER 1 | 0000 | (A) |
| PLAYER 2 | 0000 | (A) |
| COIN 1 | 0000 | (B) |
| COIN 2 | 0000 | (B) |
| ANALOG 1 | 0000 | (C) |
| ANALOG 2 | 0000 | (C) |
| ANALOG 3 | 0000 | (C) |
| ANALOG 4 | 0000 | (C) |
| ANALOG 5 | 0000 | (C) |
| ANALOG 6 | 0000 | (C) |
| ANALOG 7 | 0000 | (C) |
| ANALOG 8 | 0000 | (C) |

PRESS TEST AND SERVICE BUTTON TO EXIT

- (5) On-screen values change according to the input from switches and the volume.
- (A) SYSTEM, PLAYER
Values change with input from control panel/other switches.
 - (B) COIN
Increases with input from the COIN SWITCH. The count is cleared when exiting TEST MODE.
 - (C) ANALOG
Displays analog values from "0000" to "FFFF".
- (6) Press the SERVICE and TEST Buttons simultaneously to return to the JVS TEST main screen.

5.2.5. SOUND TEST

Use SOUND TEST to test sound output and to select the stereo/mono/surround setting.

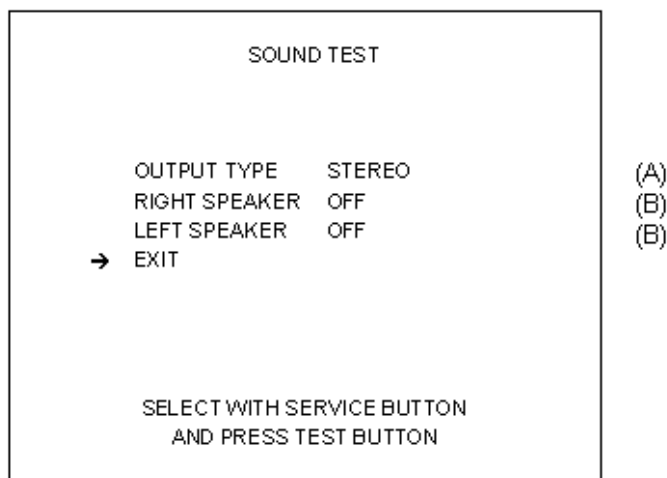

- (1) Use the SERVICE Button to move the cursor to the desired test item.
- (2) Press the TEST Button to enter the selected item.
 - (A) OUTPUT TYPE (STEREO, MONO, SURROUND)
Select the sound output from the I/O PANEL audio output interface setting among STEREO, MONO and SURROUND.
 - (B) RIGHT/LEFT SPEAKER (ON, OFF)
When set to "ON", the test sends a beep to each audio output interface. Only the word "SPEAKER" is displayed when the OUTPUT TYPE is set to "MONO", and when set to "ON", the test sends the same beep to both the left/right audio output interfaces.
To test surround output, it is necessary to use a separate Audio Amp, and receive signal from a terminal not in use at the time of shipping.
Note: Not available with this product.
- (3) Move the cursor to EXIT and press the TEST Button to return to the SYSTEM MENU screen.

5.2.6. C.R.T. TEST

Use the C.R.T. TEST to adjust monitor colours and verify screen size.

COLOUR CHECK Screen

- (1) Monitor COLOUR CHECK screen is displayed initially.
Each of the colours (red, green and blue) is darkest at the far left and gets progressively lighter (32 steps) towards the right.
Monitor brightness is set correctly if the white colour bar is black at the left edge and white at the right edge.

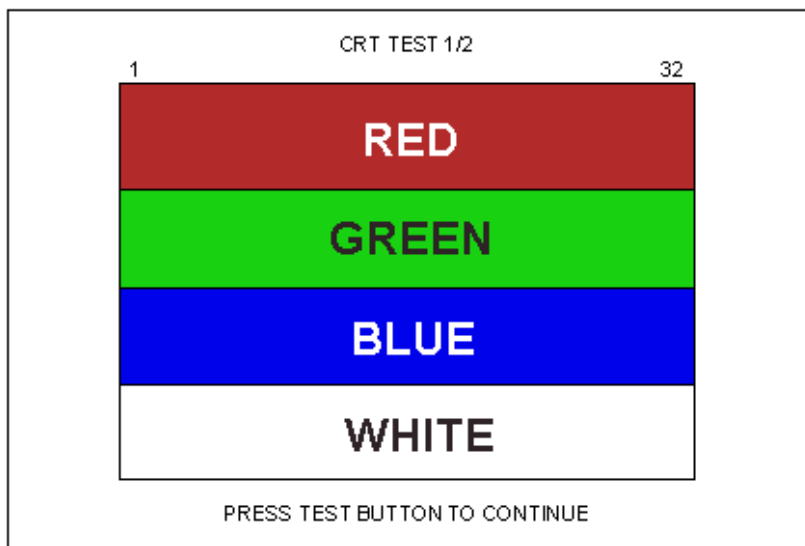

- (2) Press the TEST Button to proceed to the next page

SIZE CHECK Screen

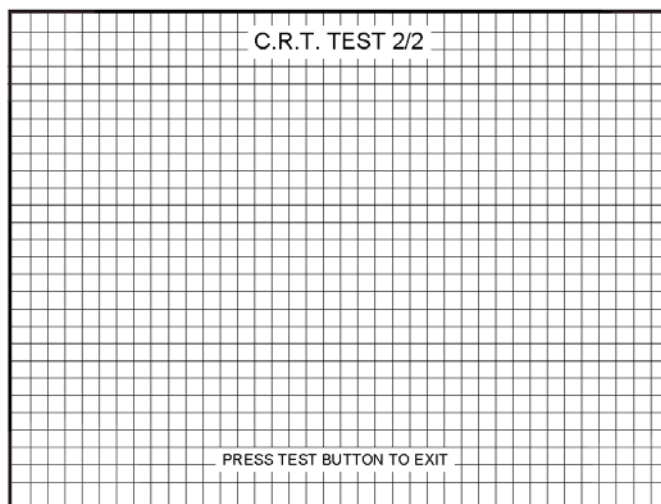

- (3) Adjust the CHECK GRID so that the entire GRID is displayed on the screen.
- (4) Press the TEST Button to return to the SYSTEM MENU screen.

5.2.7. COIN ASSIGNMENTS

Use COIN ASSIGNMENTS to set the credit rate for each coin inserted.

- (1) Use the SERVICE Button to move the cursor to the desired test item.
- (2) Press the TEST Button to change the setting or to open the detailed settings.
- (3) Move the cursor to EXIT and press the TEST Button to return to the SYSTEM MENU screen.

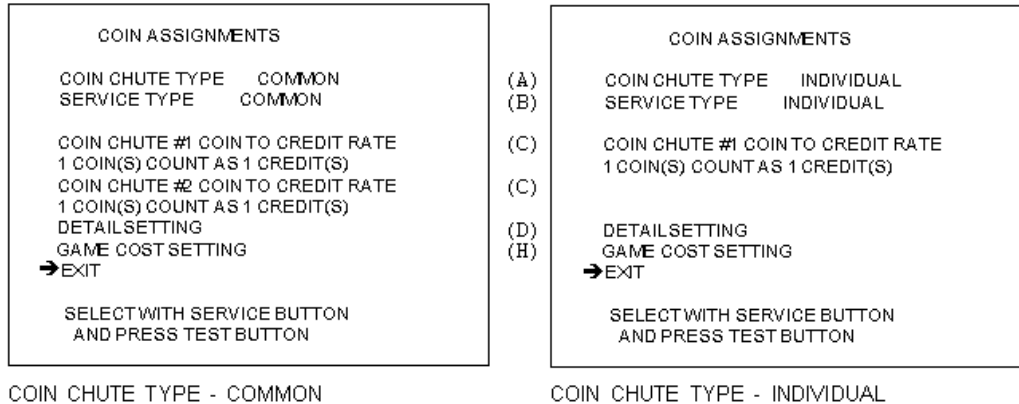

(A) COIN CHUTE TYPE (COMMON, INDIVIDUAL)

Adjust settings according to the specs of the cabinet COIN CHUTE.

COMMON

This is for cabinets where a single COIN CHUTE is used by multiple players.

Coins inserted by each player are treated as common credits.

Up to 2 COIN CHUTES (#1 and #2) may be used. The (C) COIN TO CREDIT RATE setting for COIN CHUTE #1 and #2 may be set differently.

INDIVIDUAL

This is for cabinets with individual COIN CHUTES for each player.

Coins inserted by each player are treated as individual player credits.

The (C) COIN TO CREDIT RATE setting is used by all COIN CHUTES.

(B) SERVICE TYPE (COMMON, INDIVIDUAL)

Use this to set the function of each SERVICE Button when there is more than one SERVICE Button.

COMMON

Pressing any SERVICE Button enters service credits for all players.

INDIVIDUAL

Pressing the SERVICE Button enters service credits only for the corresponding player.

- (C) COIN TO CREDIT RATE
 Set the CREDIT RATE for each coin inserted.
 The " Δ COIN(S) COUNT AS \square CREDIT(S)" setting indicates that "Inserting Δ coins equals \square credits".
 Set this to "FREE PLAY" to allow game play without credits.
 When (A) COIN CHUTE TYPE is set to "COMMON", COIN CHUTE #2 settings are restricted to some extent by the settings for COIN CHUTE #1.
- (D) DETAIL SETTING
 This mode allows for more detailed credit rate settings than the (C) COIN TO CREDIT RATE setting.
 Changes made in DETAIL SETTING override any (C) COIN TO CREDIT RATE settings.

DETAIL SETTING Screen

```

COIN ASSIGNMENTS
DETAIL SETTING
COIN CHUTE #1 MULTIPLIER
1 COIN COUNT AS 1 COIN(S)
COIN CHUTE #2 MULTIPLIER
1 COIN COUNT AS 1 COIN(S)
BONUS ADDER      NO BONUS ADDER
COIN TO CREDIT  1 COIN(S) 1 CREDIT
→EXIT
COIN CHUTE #1 OPERATION
COIN  1 2 3 4 5 6 7 8 9
CREDIT 1 2 3 4 5 6 7 8 9
COIN CHUTE #2 OPERATION
COIN  1 2 3 4 5 6 7 8 9
CREDIT 1 2 3 4 5 6 7 8 9
      SELECT WITH SERVICE BUTTON
      AND PRESS TEST BUTTON
  
```

COIN CHUTE TYPE --- COMMON

(E)

(E)

(F)

(G)

```

COIN ASSIGNMENTS
DETAIL SETTING
COIN CHUTE #1 MULTIPLIER
1 COIN COUNT AS 1 COIN(S)

      BONUS ADDER      NO BONUS ADDER
COIN TO CREDIT  1 COIN(S) 1 CREDIT
→EXIT
COIN CHUTE #1 OPERATION
COIN  1 2 3 4 5 6 7 8 9
CREDIT 1 2 3 4 5 6 7 8 9

      SELECT WITH SERVICE BUTTON
      AND PRESS TEST BUTTON
  
```

COIN CHUTE TYPE --- INDIVIDUAL

- (E) COIN CHUTE MULTIPLIER
 Use this to set how many coins will be counted for each coin inserted.
 The "1 COIN COUNT AS Δ COIN(S)" setting indicates that "Each coin will be counted as Δ coins".
 When the (A) COIN CHUTE TYPE is set to "COMMON", the setting may be set individually for COIN CHUTE #1 and #2.
- (F) BONUS ADDER
 Use this to set the number of coins calculated with the (E) COIN CHUTE MULTIPLIER setting that need to be inserted to get 1 bonus coin. When the (A) COIN CHUTE TYPE is set to "COMMON", the sum of the coins for COIN CHUTE #1 and #2 is used for the calculation.
 The " Δ COINS GIVE 1 EXTRA COIN" setting indicates that "For every Δ coins, 1 bonus coin is given".
 Set this to "NO BONUS ADDER" to disable bonus coins entirely.
- (G) COIN TO CREDIT
 Use this to set how many coins calculated with the (F) BONUS ADDER setting count as 1 credit.
 The " Δ COIN(S) 1 CREDIT" setting indicates that "Every Δ coins equals 1 credit."

(H) GAME COST SETTING

Use this mode to set the number of credits required to start a game.
Screens may differ depending on the game.

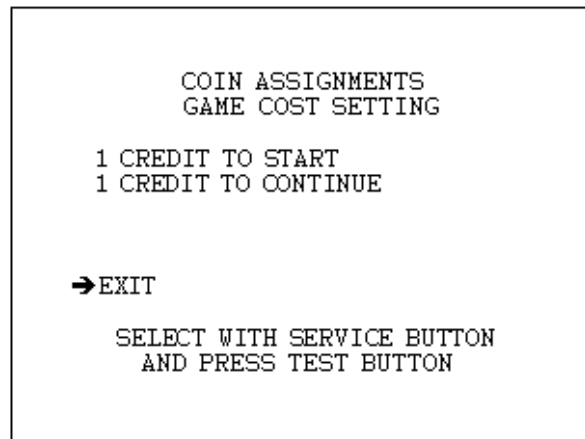

(I)
(J)

(I) Set the number of credits required to start a game.

(J) Set the number of credits required to continue a game.

5.2.8. CLOCK SETTING

Use the SERVICE Button to move the cursor to the item to be set.



- (1) Move the cursor to the desired item and press the TEST Button to increase values.
- (2) The max value for YEAR is "2099"; further increases return the value to "2000".
- (3) Move the cursor to EXIT and press the TEST Button to return to the SYSTEM MENU screen.

5.2.9. NETWORK SETTING (CORE)

Use the LAN PORT attached to the Main Board, and carry out the settings necessary for network communication.



***This game does not support network communication connections. ***

THIS OPTION IS FOR POSSIBLE FUTURE GAMES ONLY.
SELECT EXIT AND GO DIRECTLY TO THE NEXT TEST MODE.

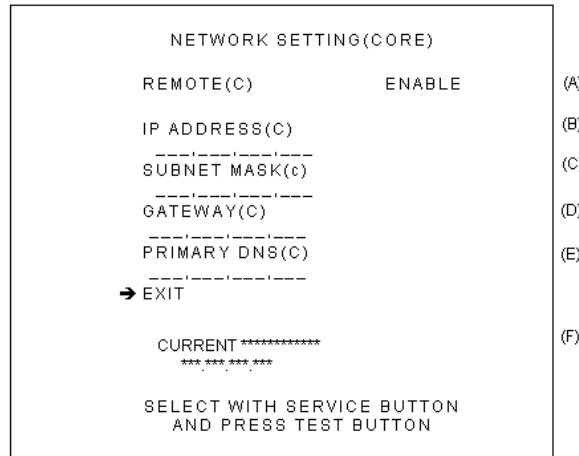

- (1) Use the SERVICE Button to move the cursor to the desired test item.
(When setting IP ADDRESS, SUBNET MASK, GAME WAY or PRIMARY DNS, use the underline as a guide.)
 - (2) Press the TEST Button to change the setting.
 - (3) Move the cursor to EXIT and press the TEST Button to return to the SYSTEM MENU screen.
- (A) REMOTE (C)
This sets up whether a communication setting is automatic or manual.
ENABLE: Sets the communication setting automatically.
DISABLE: Sets the communication setting manually.
- (B) IP ADDRESS (C)
This is one of the settings required for communication network. After setting the number, press TEST Button on SET position to memorize the setting. If you set the REMOTE setting to ENABLE, you cannot select this.
- (C) SUBNET MASK (C)
This is one of the settings required for communication network. After setting the number, press TEST Button on SET position to memorize the setting. If you set the REMOTE setting to ENABLE, you cannot select this.
- (D) GATE WAY (C)
This is one of the settings required for communication network. After setting the number, press TEST Button on SET position to memorize the setting. If you set the REMOTE setting to ENABLE, you cannot select this.
- (E) PRIMARY DNS (C)
This is one of the settings required for communication network. After setting the number, press TEST Button on SET position to memorize the setting. If you set the REMOTE setting to ENABLE, you cannot select this.
- (F) CURRENT
This displays the present setting value during a set-up of each item [(B), (C), (D), (E)]. Pressing TEST Button on SET position, the settings are memorized and the screen is changed.

5.2.10.NETWORK SETTING (MEDIA)

Use NETWORK SETTING to establish and test network connections.
This is only displayed when a network enabled MEDIA BOARD is connected to the Chihiro.

| | |
|---|---|
|  | <p>*This game does not support network communication connections. *</p> <p>THIS OPTION IS FOR POSSIBLE FUTURE GAMES ONLY. SELECT EXIT AND GO DIRECTLY TO THE NEXT TEST MODE.</p> |
|---|---|

Set (A) NETWORK TYPE to "NONE".

- (1) Use the SERVICE Button to move the cursor to the desired test item.
- (2) Press the TEST Button to change the setting or to open the detailed settings.
- (3) Move the cursor to EXIT and press the TEST Button to return to the SYSTEM MENU screen.

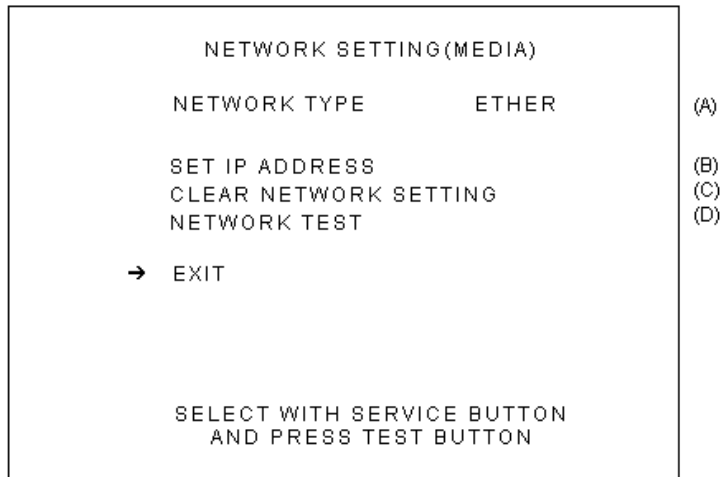

- (A) NETWORK TYPE
Choose a type of the communication network.

NONE: Sets that the communication system does not perform. Sets to NONE when you don't set the network system.

ETHER: Sets ETHER for the communication network.

MOBILE: Sets a mobile communication terminal for the communication network.

ETHER + MOBILE
DEFAULT ETHER: Set ETHER or MOBILE automatically for the communication network. Priority is given to ETHER.

ETHER + MOBILE
DEFAULT MOBILE: Set ETHER or MOBILE automatically for the communication network. Priority is given to MOBILE.

(B) SET IP ADDRESS

This sets up the details of the communication network. Depending on the NETWORK TYPE setting, the contents of setting vary. If setting to NONE, it does not appear.

*ETHER Setting

| | |
|--|-----|
| SET IP ADDRESS 1/1 | |
| ->REMOTE ENABLE | (E) |
| IP ADDRESS(E) | (F) |
| . . | |
| SUBNET MASK(E) | (G) |
| . . | |
| EXIT | |
| | |
| CURRENT ***** | (I) |
| *** . *** . *** . *** | |
| SELECT WITH SERVICE BUTTON | |
| AND PRESS TEST BUTTON | |

*MOBILE Setting

| | |
|--|-----|
| SET IP ADDRESS 1/1 | |
| ->IP ADDRESS(M) | (H) |
| . . | |
| EXIT | |
| | |
| CURRENT ***** | (I) |
| *** . *** . *** . *** | |
| SELECT WITH SERVICE BUTTON | |
| AND PRESS TEST BUTTON | |

* ETHER + MOBILE Settings

| | |
|---|-----|
| SET IP ADDRESS 1/1 | |
| ->REMOTE ENABLE | (E) |
| IP ADDRESS(E) _ _ . _ _ . _ _ . _ _ | (F) |
| SUBNET MASK(E) _ _ . _ _ . _ _ . _ _ | (G) |
| IP ADDRESS(M) _ _ . _ _ . _ _ . _ _ | (H) |
| EXIT | |
| CURRENT ***** | |
| *** . *** . *** . *** | |
| SELECT WITH SERVICE BUTTON AND PRESS TEST BUTTON | |

- (1) Use the SERVICE Button to move the cursor to the desired test item.
(When setting IP ADDRESS or SUBNET MASK, use the underline as a guide.)
 - (2) Press the TEST Button to change the setting.
 - (3) Move the cursor to EXIT and press the TEST Button to return to the NETWORK SETTING screen.
-
- (E) REMOTE
This sets up whether a communication setting is automatic or manual.
ENABLE: Sets the communication setting automatically.
DISABLE: Sets the communication setting manually.
 - (F) IP ADDRESS (E)
This is one of the settings required for communication network. After setting the number, press TEST Button on SET position to memorize the setting. If you set the REMOTE setting to ENABLE, you cannot select this.
 - (G) SUBNET MASK (E)
This is one of the settings required for communication network. After setting the number, press TEST Button on SET position to memorize the setting. If you set the REMOTE setting to ENABLE, you cannot select this.
 - (H) IP ADDRESS (M)
This is one of the settings required for communication network. Set the number according to the Game Soft manual. After setting the number, press TEST Button on SET position to memorize the setting.
 - (I) CURRENT
This displays the present setting value during a set-up of each item [(F), (G), (H)]. Pressing TEST Button on SET position, the settings are memorized and the screen is changed.

(C) CLEAR NETWORK SETTING

Use this to return all values in the NETWORK SETTING to the default values and turn off network communication.

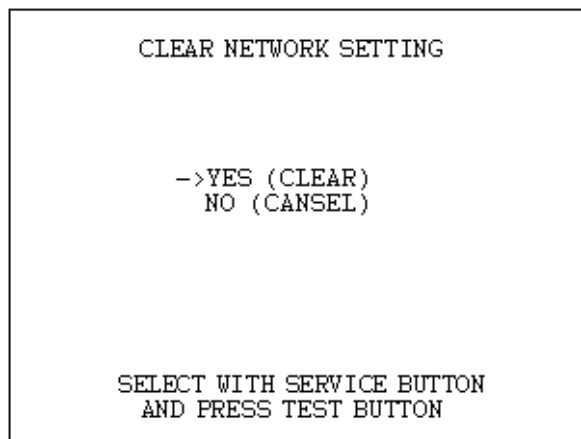

To clear data, use the SERVICE Button to move the cursor to YES (CLEAR) and press the TEST Button. When the data has been cleared, the message "COMPLETED" is displayed.

Press the TEST Button again to return to the NETWORK SETTING main screen.

Move the cursor to NO (CANCEL) and press the TEST Button to return to the NETWORK SETTING main screen without clearing the data.

NETWORK TEST

In this test, the checking for the communication network can be performed. Entering this test mode, checking starts immediately.

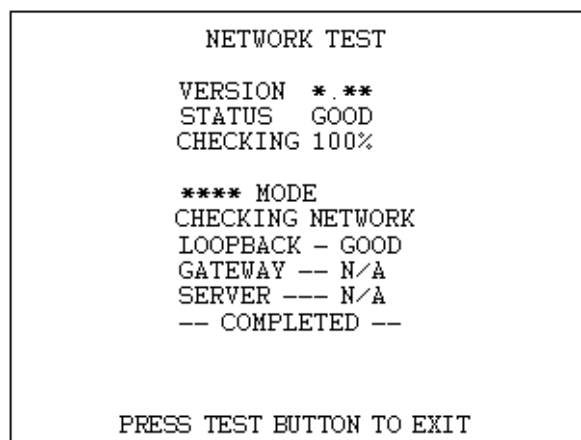

The display changes to "GOOD" when the checking is finished successfully, and changes to "BAD" when any problem is detected. If the connection is not permitted, the display will change to "N/A".

If you perform this test immediately after the setting change, it may not display the correct result. In this case, be sure to turn the power off and on, and enter this test mode again.

5.3. GAME TEST MODE

| | |
|---|---|
|  <p>STOP IMPORTANT</p> | <ul style="list-style-type: none">• When changing the game configuration, changes will not take effect until the Game Test Mode has been completed. Be sure to exit the Game Test Mode properly after configuration changes.• Do not configure the game in ways not described in this text. It is possible that the game will not function properly. |
|---|---|

Select ENTER GAME TEST from the System Menu screen to display the GAME TEST MENU screen as follows.

Use the SERVICE Button to move the cursor to the desired test item.
Press the TEST Button to enter the selected item's test.

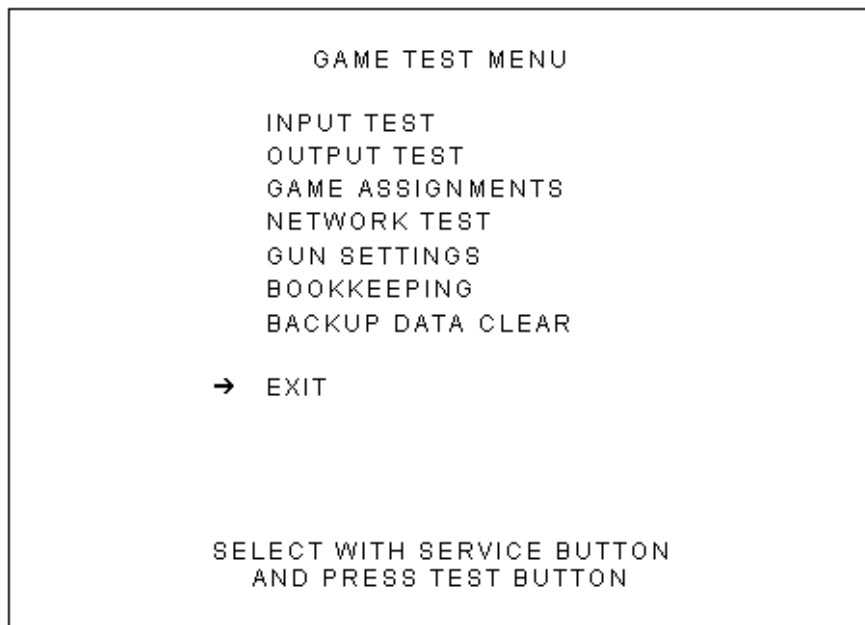

Performs test, adjustments and settings for each of the Game Test Menu screen items below.

- * INPUT TEST: Tests each input device used in the game.
- * OUTPUT TEST: Tests each output device used in the game.
- * GAME ASSIGNMENTS: Adjusts game settings.
- * GUN SETTING: Performs sight settings for the game's Control Unit (Shotgun).
- * BOOKKEEPING: View all recorded game data.
- * BACKUP DATA CLEAR: Erase all game records.

After selecting an item, read the explanations below regarding operation.

After performing tests and adjustments, return to the Game Test Menu screen, select EXIT and press the TEST Button. You will return to the System Menu Screen.

Move the cursor to EXIT on System Menu screen and press the TEST Button to return to the Game Play screen.

5.3.1. INPUT TEST

Select INPUT TEST to display the following screen and check the status of input devices. This test should be used periodically to check that each input device is functioning correctly.

| INPUT TEST | | |
|------------|---------|---------|
| | PLAYER1 | PLAYER2 |
| START | OFF | OFF |
| TRIGGER | OFF | OFF |
| GRIP | OFF | OFF |
| GUN-X | 00 | 00 |
| GUN-Y | 00 | 00 |
| SCREEN-IN | OUT | OUT |
| SERVICE | OFF | |
| TEST | OFF | |

PRESS TEST BUTTON TO EXIT

The items refer to the following input devices.

- * START: The player START Buttons.
- * TRIGGER: The gun triggers.
- * GRIP: The gun grips.
- * GUN-X: The X-direction (horizontal) sight position for the guns.
- * GUN-Y: The Y-direction (vertical) sight position for the guns.
- * SCREEN-IN: Detection of the gun sight sensors.
- * SERVICE: The SERVICE Button.
- * TEST: The TEST Button.

* Input is normal if the display to the right of each item changes from OFF to ON when each input device is operated.

* Input is normal if the display to the right of SCREEN-IN changes from OUT to IN when the shotgun is pointed at the screen.

* Input is normal if the display values to the right of GUN-X and GUN-Y change according to the movement of the guns when they are pointed at the screen and moved.

Press the SERVICE and TEST Buttons simultaneously to return to the Game Test Menu screen.

5.3.2. OUTPUT TEST

Select OUTPUT TEST to display the following screen and check the status of each lamp. This test should be used periodically to check that the lamps are functioning correctly.

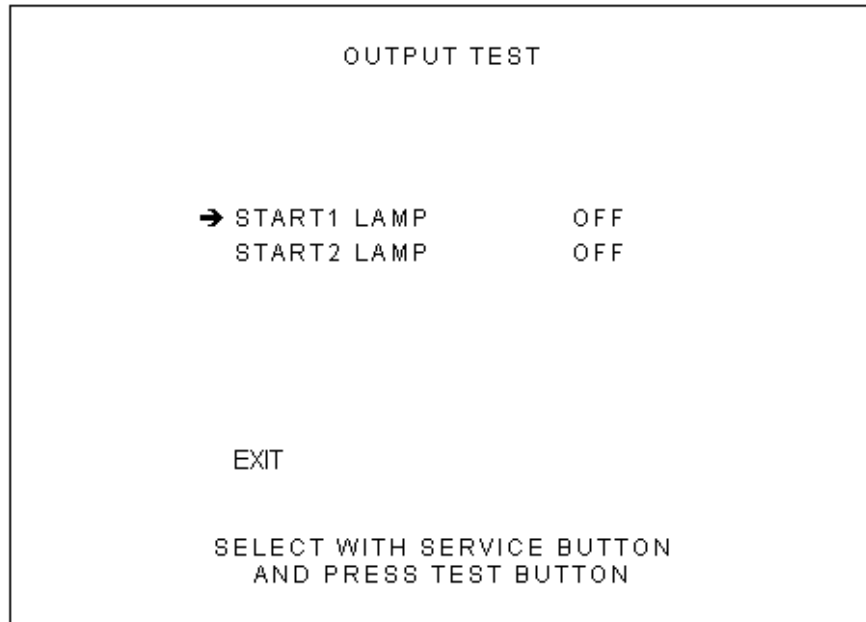

Perform the tests as follows.

- * START1 LAMP: Select START1 LAMP and press the TEST Button or START Button 1. The display to the right of the item will change to ON and START Button 1 will flash.
- * START2 LAMP: Select START2 LAMP and press the TEST Button or START Button 2. The display to the right of the item will change to ON and START Button 2 will flash.

Move the cursor to EXIT and press the TEST Button to return to the Game Test Menu screen.

5.3.3. GAME ASSIGNMENTS

Select GAME ASSIGNMENTS to display the current game settings and make changes.

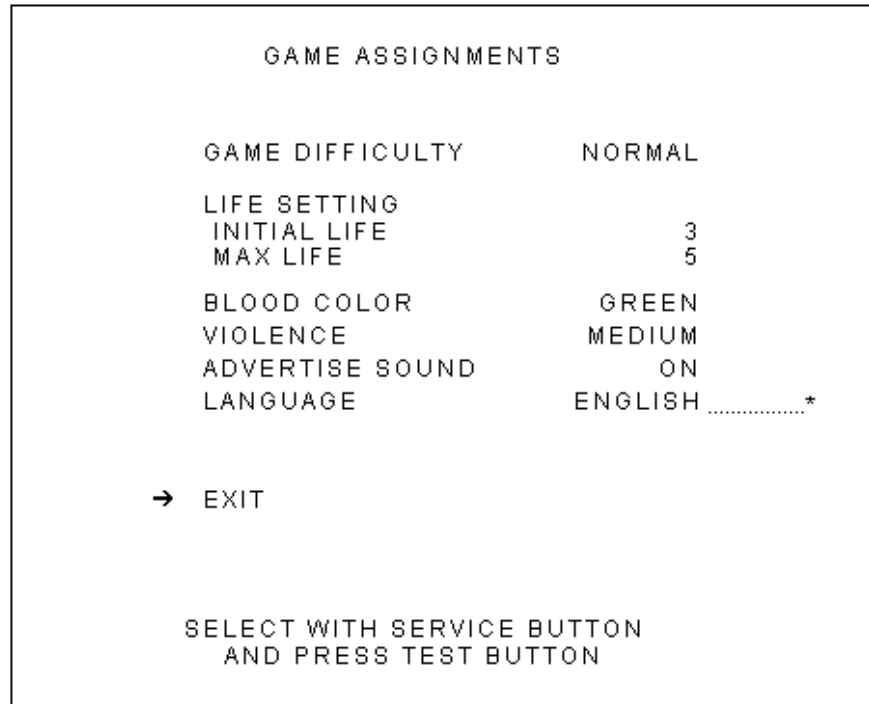

Perform the following settings for each item.

- * GAME DIFFICULTY: Set the level of difficulty to one of five levels - VERY EASY→MEDIUM EASY→NORMAL→MEDIUM HARD→VERY HARD.
- * LIFE SETTING INITIAL LIFE: Set from one to nine. It is not possible to set this above MAX LIFE.
- * LIFE SETTING MAX LIFE: Set from one to nine.
- * BLOOD COLOUR: You can set the colour of blood to one of two settings - RED or GREEN.
- * VIOLENCE: You can set the level of damage for the enemies to one of three settings - GRATUITOUS, MEDIUM or MILD.
- * ADVERTISE SOUND: You can set the 'advertise' sound to ON or OFF.
- * LANGUAGE *(Only displayed for overseas versions outside of the United States.): The selections are ENGLISH, FRENCH, ITALIAN, SPANISH and GERMAN. The subtitles and displays that appear during the game will change to the selected language. Changes to settings are not enabled until Test Mode is exited. After changing settings, be sure to exit Test Mode.

After changing the settings, select EXIT and press the TEST Button to return to the Game Test Menu screen.

5.3.4. GUN SETTING

Select GUN SETTING to display the following screen.
Perform the sight settings for the shotguns to be used in the game.

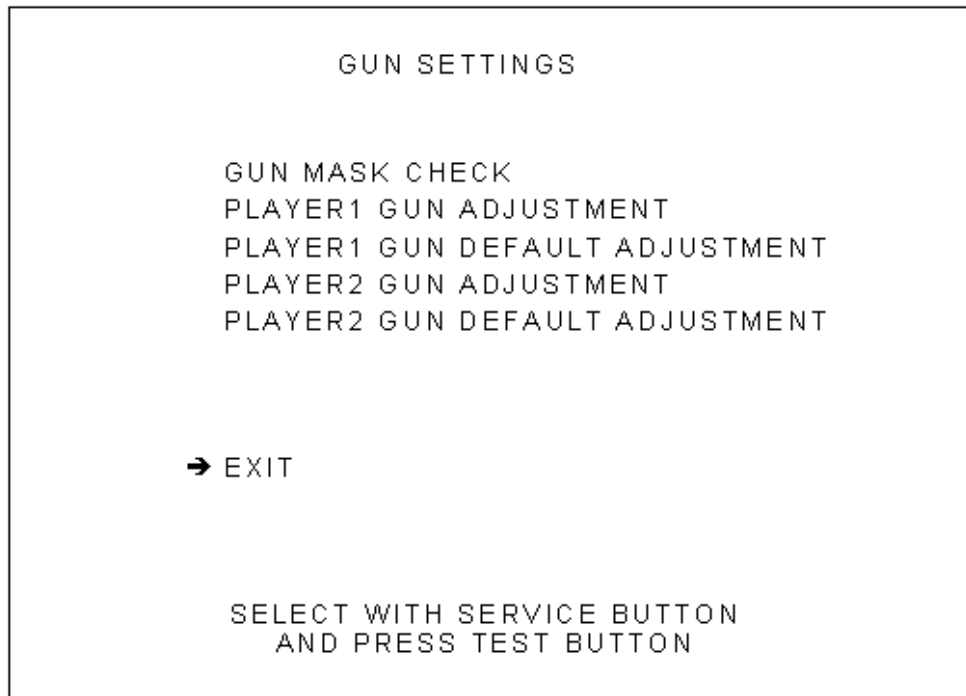

Details for each item are as follows.

- * GUN MARK CHECK: Checks the gun sights. Will check 1P and 2P guns at the same time.
- * PLAYER1 GUN ADJUSTMENT: Adjusts the sight for the Player 1 side.
- * PLAYER1 GUN DEFAULT ADJUSTMENT: Adjust the default sight settings for the Player 1 side.
- * PLAYER2 GUN ADJUSTMENT: Adjust the sight for the Player 2 side. (Operated in the same way as PLAYER1 GUN ADJUSTMENT.)
- * PLAYER2 GUN DEFAULT ADJUSTMENT: Adjust the default sight settings for the Player 2 side. (Operated in the same way as PLAYER1 GUN DEFAULT ADJUSTMENT.)

Changes to settings are not enabled until the Test Mode is exited. After changing settings, be sure to exit Test Mode.

After changing the settings, select EXIT and press the TEST Button to return to the Game Test Menu screen.

5.3.4.1.GUN MARK CHECK

This item checks gun sights.

Select GUN MARK CHECK on the Gun Setting screen and press the TEST Button.

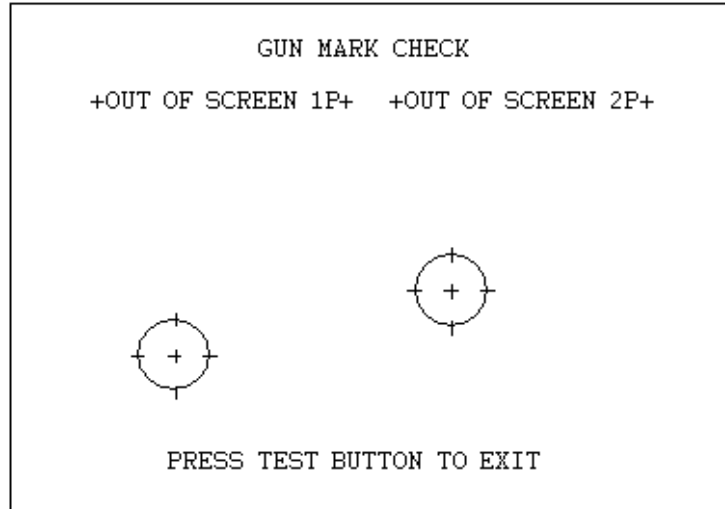

- * (1P Gun cross)
This is displayed when the gun is pointed at the screen. 1P is red.
- * (2P Gun cross)
This is displayed when the gun is pointed at the screen. 2P is blue.
- * "OUT OF SCREEN" is displayed when the gun cross is perceived to be out of screen.

Pointing the gun at the screen displays the gun cross (sight) for that gun. You can check to see if the sight lines up properly at this screen.

Press the TEST Button when everything has been checked. You will return to the Gun Setting screen.

5.3.4.2.PLAYER1 GUN ADJUSTMENT/PLAYER2 GUN ADJUSTMENT

This item adjusts the Player 1 gun sight.
(This is the same for "PLAYER2 GUN ADJUSTMENT".)

- (1) Select PLAYER1 GUN ADJUSTMENT on the Gun Setting screen and press the TEST Button.

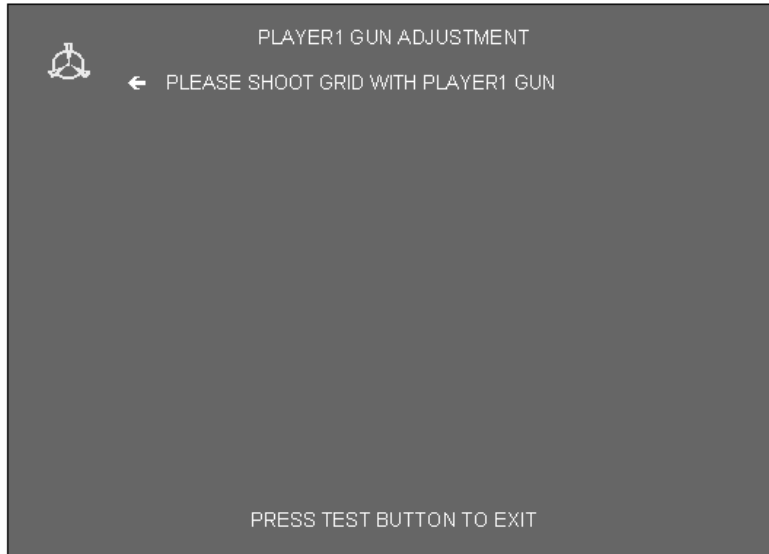

- (2) Follow the on-screen instructions to adjust the gun sight settings. Aim at the mark in the upper left corner and fire. The mark in the upper left will disappear, and the same mark will be displayed in the lower right corner.

(If the TEST Button is pressed, settings will be cancelled and will return to the Gun Setting screen.)

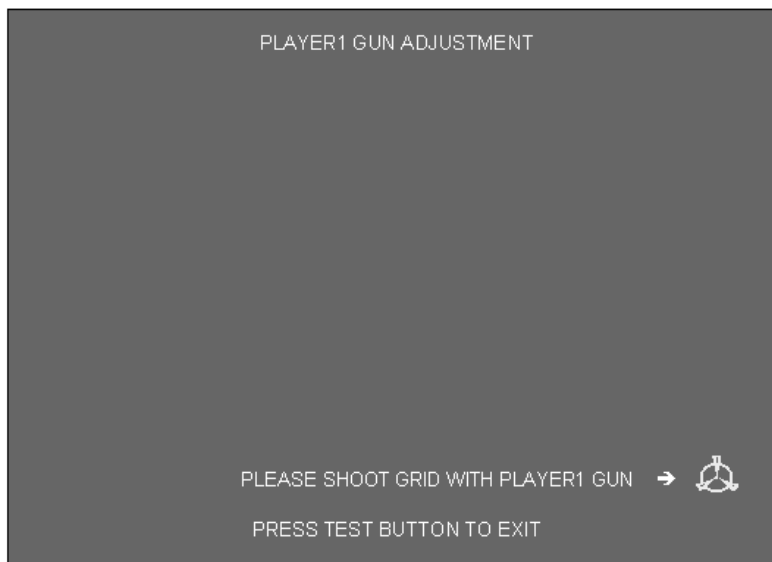

- (3) Aim and fire at the mark to the lower right. The mark to the lower right will disappear, and the same mark will be displayed in the centre.
(If the TEST Button is pressed, settings will be cancelled and will return to the Gun Setting screen.)

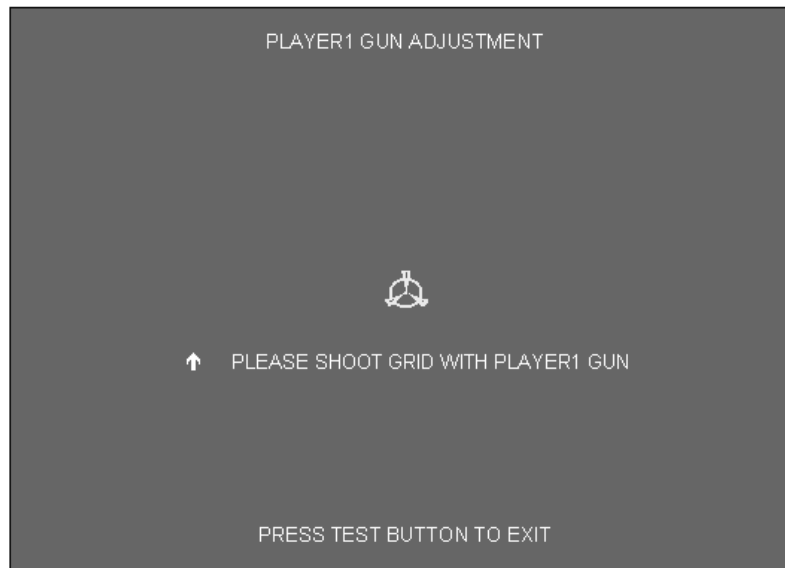

- (4) Aim and fire at the mark in the centre. "NOW CALCULATING" will be displayed in the centre.
(If the TEST Button is pressed, settings will be cancelled and will return to the Gun Setting screen.)

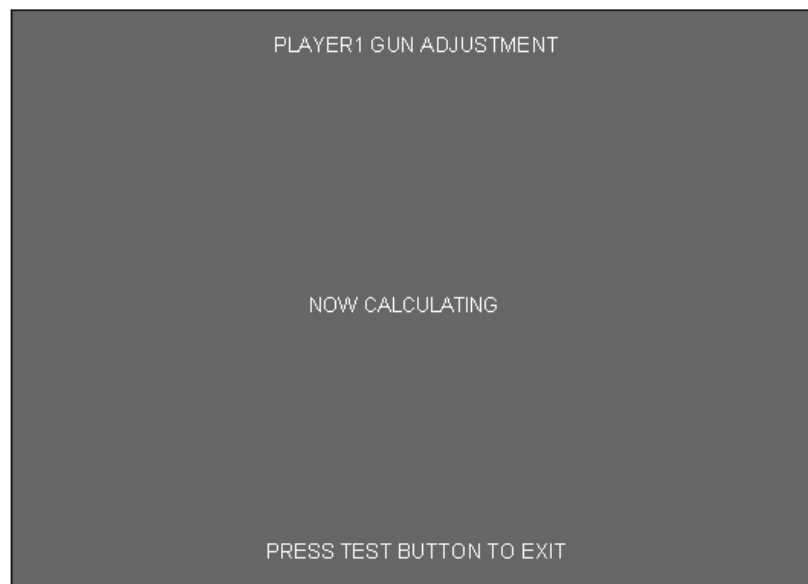

(5) The screen will automatically switch to the following.

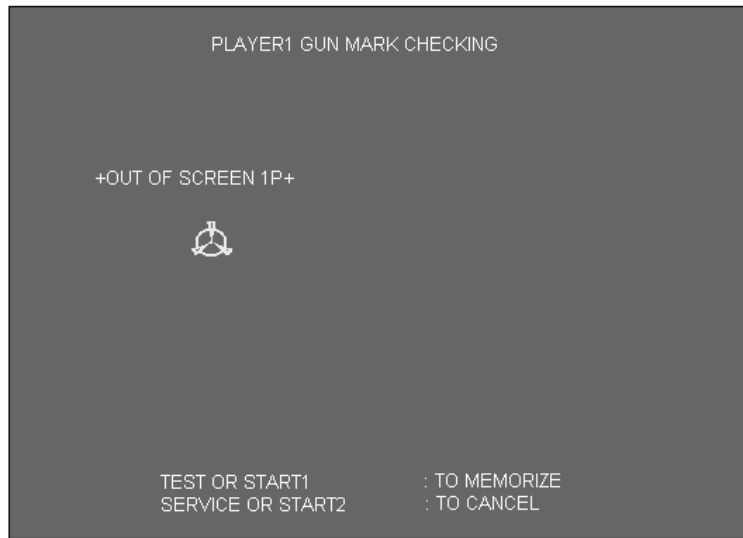

* "OUT OF SCREEN" is displayed when the gun cross is perceived to be out of screen.

(6) The gun cross is displayed in the centre. Confirm that you can aim accurately within the frame, from edge to edge.

- * When a sight is out of alignment, press the SERVICE Button or the 2P Start Button and readjust the settings. You will return to the Gun Setting screen.
- * If the sights are aligned, press the TEST Button or the 1P Start Button to record the sight settings.

Refer to the following procedure when adjusting the sights.

- * Line up the concave sight nearest you on the gun so that it is at the height of the horizontal line of the "+" mark.
- * Line up the convex sight at the tip of the gun so that it also lines up with the horizontal line.
- * Line up the centres of the tops of the concave and convex sights with the centre of the "+" and fire.

5.3.4.3.PLAYER1 GUN DEFAULT ADJUSTMENT/PLAYER2 GUN DEFAULT ADJUSTMENT

This item adjusts the sight settings to those at the time of shipment.
(This is the same for "PLAYER2 GUN DEFAULT ADJUSTMENT".)

Select PLAYER1 GUN DEFAULT ADJUSTMENT on the Gun Setting screen and press the TEST Button.

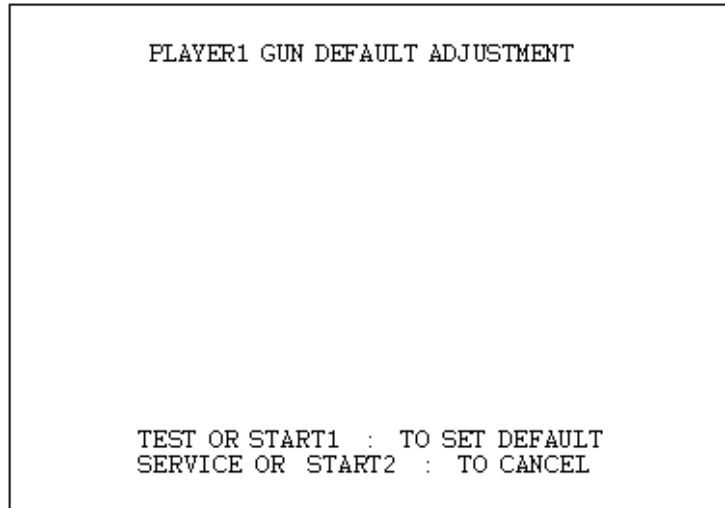

Press the TEST Button or the Player 1 Start Button to adjust the sights to the previously established default value. Press the SERVICE Button or the Player 2 Start Button to cancel.

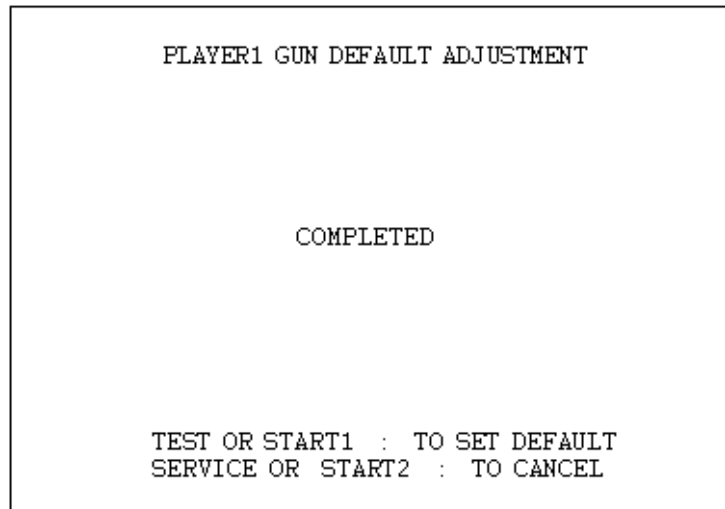

"COMPLETED" will be displayed when the adjustments are completed.

5.3.5. BOOKKEEPING

Select BOOKKEEPING on the Game Test Menu screen to display the three screens of operating status data.

| BOOKKEEPING | | PAGE 1/3 |
|-------------------------------|---|----------|
| COINS1 | 0 | |
| COINS2 | 0 | |
| TOTAL COINS | 0 | |
| COIN CREDITS | 0 | |
| SERVICE CREDITS | 0 | |
| TOTAL CREDITS | 0 | |
| PRESS TEST BUTTON TO CONTINUE | | |

The display items for the screen (Page 1 of 3) are as follows.

- * COIN 1: The number of coins inserted into Coin Slot 1.
- * COIN 2: The number of coins inserted into Coin Slot 2.
- * TOTAL COINS: The total number of coins inserted into the coin slots.
- * COIN CREDITS: The number of credits for the coins inserted.
- * SERVICE CREDITS: The number of credits input by the Service Button.
- * TOTAL CREDITS: The total number of all credits.

Press the TEST Button to display the next screen.

| BOOKKEEPING | | PAGE 2/3 |
|-------------------------------|-------------|----------|
| NUMBER OF GAMES | 0 | |
| TOTAL TIME | 00 0H 0M 0S | |
| PLAY TIME | 00 0H 0M 0S | |
| AVERAGE PLAY TIME | 0M 0S | |
| LONGEST PLAY TIME | 0M 0S | |
| SHORTEST PLAY TIME | 0M 0S | |
| PRESS TEST BUTTON TO CONTINUE | | |

The display items for the screen (Page 2 of 3) are as follows.

- * NUMBER OF GAMES: The total number of games played by 1P and 2P.
- * TOTAL TIME: The amount of time the unit has been in operation.
- * PLAY TIME: The amount of time the game has been played.
- * AVERAGE PLAY TIME: The average play time for one game.
- * LONGEST PLAY TIME: The longest play time for one game.
- * SHORTEST PLAY TIME: The shortest play time for one game.

Press the TEST Button to display the next screen.

| BOOKKEEPING | HISTOGRAM | PAGE3/3 |
|---------------------------|-----------|---------|
| 0M 00S ~ 0M 29S | 0000 | |
| 0M 30S ~ 0M 59S | 0000 | |
| 1M 00S ~ 1M 29S | 0000 | |
| 1M 30S ~ 1M 59S | 0000 | |
| 2M 00S ~ 2M 29S | 0000 | |
| 2M 30S ~ 2M 59S | 0000 | |
| 3M 00S ~ 3M 29S | 0000 | |
| 3M 30S ~ 3M 59S | 0000 | |
| 4M 00S ~ 4M 29S | 0000 | |
| 4M 30S ~ 4M 59S | 0000 | |
| 5M 00S ~ 5M 29S | 0000 | |
| 5M 30S ~ 5M 59S | 0000 | |
| 6M 00S ~ 6M 29S | 0000 | |
| 6M 30S ~ 6M 59S | 0000 | |
| 7M 00S ~ 7M 29S | 0000 | |
| 7M 30S ~ 7M 59S | 0000 | |
| 8M 00S ~ 8M 29S | 0000 | |
| 8M 30S ~ 8M 59S | 0000 | |
| 9M 00S ~ 9M 29S | 0000 | |
| 9M 30S ~ 9M 59S | 0000 | |
| OVER 10M 00S | 0000 | |
| PRESS TEST BUTTON TO EXIT | | |

This displays play times on a scale from 0M00S to 9M59S with 30-second intervals. All play times over ten minutes are included in the item OVER 10M00S.

Press the TEST Button after viewing. You will return to the Game Test Menu screen.

5.3.6. BACKUP DATA CLEAR

Select BACKUP DATA CLEAR to clear the contents of BOOKKEEPING and Score Data.

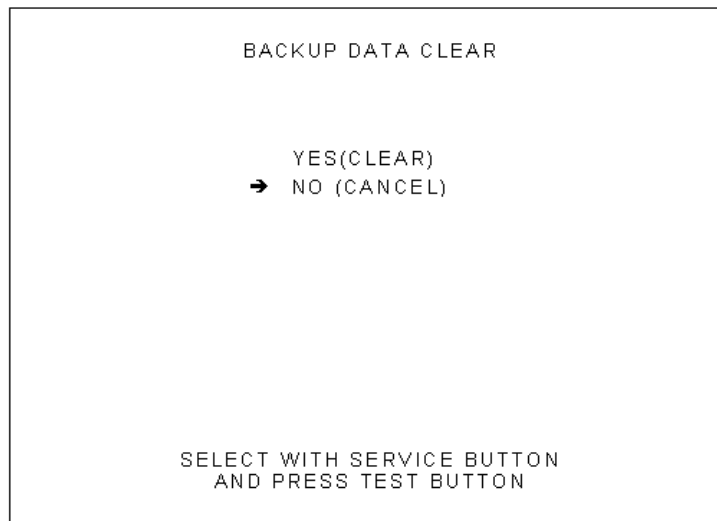

BACKUP DATA CLEAR Screen

To clear data, use the SERVICE Button to move the cursor to YES (CLEAR) and then press the TEST Button.

When the data has been cleared, the message "COMPLETED" will be displayed.

Press the TEST Button again to return to the Game Test Menu screen.

Move the cursor to NO (CANCEL) and press the TEST Button to return to the Game Test Menu screen without clearing the data.

Note that this operation does not affect the settings of the GAME ASSIGNMENTS and the GUN ADJUSTMENT.

Using the BACKUP DATA CLEAR function from this screen will not affect coin/credit data. To clear coin/credit data, use the BACKUP DATA CLEAR function in SYSTEM TEST MODE.

6. COIN MECH INSTALLATION AND CREDIT BOARD SET UP

6.1. INTRODUCTION

Game credits between the Coin Mechanism and the game board for this machine are controlled by a *VTS* board. This electronic circuit allows the price of play to be set for a range of different countries. These functions are set on Dual In Line (DIL) PCB mounted switches.

SW1 is used to set the currency (or coin ratio) and SW3 the price of play. Refer to the Tables on the following pages for the correct settings for your environment.

The *VTS* board pictured below is mounted in the Coin Chute Tower.

The *VTS* board is connected to the coin validator and lamps via a dedicated wiring harness depending upon the coin validator used:

| Wiring Harness | Validator | |
|----------------|---------------|--------------------|
| LM1006 | Coin Controls | (15 way connector) |
| LM1007 | Mars | (13 way connector) |
| LM1008 | Mechanical | See note 2 |
| N/A | NRI | See note 1 |

Notes

1. If NRI mechanisms are to be used, these should be ordered with the highest denomination coin on coin path #1 and the lowest denomination on coin path #4. The *VTS* board should be then be set up for either the UK or Switzerland settings. A minimum connecting lead length of 600mm is required.
2. Mechanical coin mechanisms may be connected in parallel allowing two identical mechanisms to be fitted.

The *VTS* Board

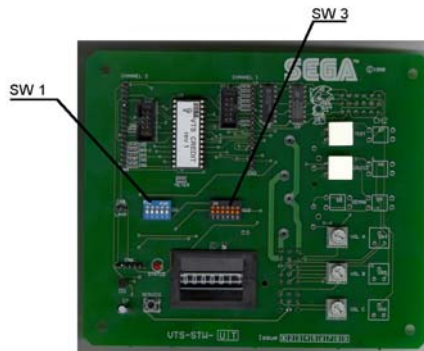

| Credit Board Mode Settings Switch 3 | | | | | | | | | | | | | | | | | | | |
|-------------------------------------|-----------------------------|------------------|-----|-----|-----|-----|-----|----------------------------|--------------|----------------|------------|------------|-----------|--|-----------|---------------|-----------|-----------|--------|
| Country | Setting | Switch 3 Setting | | | | | | Coin Validator Programming | | | | | | | | C120/SR3 Only | | | |
| | | SW1 | SW2 | SW3 | SW4 | SW5 | SW6 | COIN1 | COIN2 | COIN3 | COIN4 | COIN5 | COIN6 | COIN7 | COIN8 | COIN9 | COIN10 | COIN11 | COIN12 |
| UK | Coin Controls C220 Parallel | OFF | OFF | OFF | OFF | | | £1 | 50p new | 20p | 10p | - | 50p old | - | - | | | | |
| UK | Coin Controls C220 Binary | ON | OFF | OFF | OFF | | | £1 | 50p new | 20p | 10p | - | 50p old | - | £2 | | | | |
| UK | Coin Controls C220 Binary | OFF | ON | OFF | OFF | | | £1 | 50p new | 20p | 10p | - | £2 | - | 50p old | | | | |
| UK | Coin Controls SR3 Parallel | ON | ON | OFF | OFF | | | £1 | 50p new | 20p | 10p | - | £2 | - | 50p old | - | - | - | - |
| UK Euro | Coin Controls SR3 Parallel | OFF | OFF | ON | OFF | | | £2 €2 | £1 €1 | 50p new 50¢ | 20p 20¢ | 10p 10¢ | - | - | - | 50p old | - | - | - |
| UK | Mars ME/MS 111 Parallel | ON | OFF | ON | OFF | | | £1 | £2 | 20p | 10p | 50p new | 50p old | | | | | | |
| UK | NRI Parallel | OFF | ON | ON | OFF | | | 10p | 20p | 50p | £1 | £2 | - | | | | | | |
| Belgium | Parallel | ON | ON | ON | OFF | | | - | 50BFr | 20BFr | 5BFr | | | | | | | | |
| Holland | Parallel | OFF | OFF | OFF | ON | | | - | 5NLG | 2.5NLG | 1NLG | | | | | | | | |
| Austria | SR3 Parallel | ON | OFF | OFF | ON | | | 20Sch | 10Sch | 5Sch | 1Sch | | | | | | | | |
| Spain | Coin Controls C220 Binary | OFF | ON | OFF | ON | | | 500Pta | 200Pta | 100Pta | 50Pta | 25Pta | 200Pt old | 50Pta old | 25Pta old | | | | |
| Spain | SR3/NRI Parallel | ON | ON | OFF | ON | | | 500Pta | 200Pta | 100Pta | 50Pta | 25Pta | - | - | 200Pta | - | 50Pta old | 25Pta old | - |
| Spain | Coin Controls C220 Parallel | OFF | OFF | ON | ON | | | 100Pta | 50Pta new | - | 25Pta new | - | 50Pta old | - | 25Pta old | | | | |
| Portugal Euro | Parallel | ON | OFF | ON | ON | | | 200Es €1 | 100Es 50¢ | 50Es | - | - | - | - | - | | | | |
| | TBA | | | | | OFF | | TBA | | | | | | Please Note The credit board automatically sets the validator for parallel and binary operation through an output on pin 8 of the 17 way pinstrip. For the feature to work it is necessary for the validator interconnecting cable to include at wire at this position | | | | | |
| | | | | | | ON | | TBA | | | | | | | | | | | |
| | Channels | | | | | | OFF | Direct Mode | | | | | | | | | | | |
| | | | | | | | ON | 2 channel Mode | | | | | | | | | | | |

Note: These switch settings are under constant review and may change due to world currency updates.

- Set SW 1 according to the option settings found in the relevant Price of Play Settings Table on the following pages.
- For Germany (DM), France (Fr) & Switzerland (SFr), use the appropriate existing setting shown above (from another country) that matches the coin ratios programmed into your coin mech.
- Set SW 3 on the VTS /Excel board as shown in the table above corresponding to the country required.

6.1.1. PRICE OF PLAY SETTINGS UK

| | Price | Bonus | | | DIL Switch 1 | | | | |
|----|-------|------------|-----------|----------|--------------|------------|-----------|-----------|-----------|
| | | | | | Switch 1 | Switch 2 | Switch 3 | Switch 4 | Switch 5 |
| 1 | 10p | No Bonus | | | OFF | OFF | OFF | OFF | OFF |
| 2 | 10p | 6 = 50p | | | ON | OFF | OFF | OFF | OFF |
| 3 | 20p | No Bonus | | | OFF | ON | OFF | OFF | OFF |
| 4 | 20p | 3 = 50p | 6 = £1 | 12 = £2 | ON | ON | OFF | OFF | OFF |
| 5 | 30p | No Bonus | | | OFF | OFF | ON | OFF | OFF |
| 6 | 30p | 1.66 = 50p | 4 = £1 | 8 = £2 | ON | OFF | ON | OFF | OFF |
| 7 | 30p | 2 = 50p | 4 = £1 | | OFF | ON | ON | OFF | OFF |
| 8 | 30p | AMLD * | 3 = £1 | 6 = £2 | ON | ON | ON | OFF | OFF |
| 9 | 40p | No Bonus | | | OFF | OFF | OFF | ON | OFF |
| 10 | 40p | 1.25 = 50p | 3 = £1 | 6 = £2 | ON | OFF | OFF | ON | OFF |
| 11 | 50p | No Bonus | | | OFF | ON | OFF | ON | OFF |
| 12 | 50p | | 3 = £1 | 6 = £2 | ON | ON | OFF | ON | OFF |
| 13 | 50p | | 2 = £1 | 5 = £2 | OFF | OFF | ON | ON | OFF |
| 14 | 60p | No Bonus | | | ON | OFF | ON | ON | OFF |
| 15 | 60p | | 2 = £1 | 4 = £2 | OFF | ON | ON | ON | OFF |
| 16 | 80p | No Bonus | | | ON | ON | ON | ON | OFF |
| 17 | 80p | 1.25 = £1 | 2 = £1.50 | 2.5 = £2 | OFF | OFF | OFF | OFF | ON |
| 18 | £1 | No Bonus | | | ON | OFF | OFF | OFF | ON |
| 19 | £1 | | 3 = £2 | | OFF | ON | OFF | OFF | ON |
| 20 | £1 | | 2 = £2 | 5 = £4 | ON | ON | OFF | OFF | ON |
| 21 | £1.50 | No Bonus | | | OFF | OFF | ON | OFF | ON |
| 22 | £1.50 | | 2 = £2 | | ON | OFF | ON | OFF | ON |
| 23 | £2 | No Bonus | | | OFF | ON | ON | OFF | ON |
| 24 | £2 | | | 3 = £5 | ON | ON | ON | OFF | ON |
| 25 | £3 | No Bonus | | | OFF | OFF | OFF | ON | ON |
| 26 | £3 | | | 2 = £5 | ON | OFF | OFF | ON | ON |
| 27 | £5 | No Bonus | | | OFF | ON | OFF | ON | ON |
| 28 | £5 | | | 3 = £10 | ON | ON | OFF | ON | ON |
| 29 | £7.50 | No Bonus | | | OFF | OFF | ON | ON | ON |
| 30 | £7.50 | | | 2 = £10 | ON | OFF | ON | ON | ON |
| 31 | £10 | No Bonus | | | OFF | ON | ON | ON | ON |
| 32 | | Free Play | | | ON | ON | ON | ON | ON |

6.1.2. PRICE OF PLAY SETTINGS EURO

| | Price | Bonus | | | DIL Switch 1 | | | | |
|----|-----------|------------|-----------|----------|--------------|------------|-----------|-----------|-----------|
| | | | | | Switch 1 | Switch 2 | Switch 3 | Switch 4 | Switch 5 |
| 1 | 10¢ | No Bonus | | | OFF | OFF | OFF | OFF | OFF |
| 2 | 10¢ | 6 = 50¢ | | | ON | OFF | OFF | OFF | OFF |
| 3 | 20¢ | No Bonus | | | OFF | ON | OFF | OFF | OFF |
| 4 | 20¢ | 3 = 50¢ | 6 = €1 | 12 =€2 | ON | ON | OFF | OFF | OFF |
| 5 | 30¢ | No Bonus | | | OFF | OFF | ON | OFF | OFF |
| 6 | 30¢ | 1.66 = 50¢ | 4 = €1 | 8 = €2 | ON | OFF | ON | OFF | OFF |
| 7 | 30¢ | 2 = 50¢ | 4 = €1 | | OFF | ON | ON | OFF | OFF |
| 8 | 30¢ | AMLD * | 3 = €1 | 6 = €2 | ON | ON | ON | OFF | OFF |
| 9 | 40¢ | No Bonus | | | OFF | OFF | OFF | ON | OFF |
| 10 | 40¢ | 1.25 = 50¢ | 3 = €1 | 6 = €2 | ON | OFF | OFF | ON | OFF |
| 11 | 50¢ | No Bonus | | | OFF | ON | OFF | ON | OFF |
| 12 | 50¢ | | 3 = €1 | 6 = €2 | ON | ON | OFF | ON | OFF |
| 13 | 50¢ | | 2 = €1 | 5 = €2 | OFF | OFF | ON | ON | OFF |
| 14 | 60¢ | No Bonus | | | ON | OFF | ON | ON | OFF |
| 15 | 60¢ | | 2 = €1 | 4 = €2 | OFF | ON | ON | ON | OFF |
| 16 | 80¢ | No Bonus | | | ON | ON | ON | ON | OFF |
| 17 | 80¢ | 1.25 = £1 | 2 = €1.50 | 2.5 = €2 | OFF | OFF | OFF | OFF | ON |
| 18 | €1 | No Bonus | | | ON | OFF | OFF | OFF | ON |
| 19 | €1 | | 3 = €2 | | OFF | ON | OFF | OFF | ON |
| 20 | €1 | | 2 = €2 | 5 = €4 | ON | ON | OFF | OFF | ON |
| 21 | €1.50 | No Bonus | | | OFF | OFF | ON | OFF | ON |
| 22 | €1.50 | | 2 = €2 | | ON | OFF | ON | OFF | ON |
| 23 | €2 | No Bonus | | | OFF | ON | ON | OFF | ON |
| 24 | €2 | | | 3 = €5 | ON | ON | ON | OFF | ON |
| 25 | €3 | No Bonus | | | OFF | OFF | OFF | ON | ON |
| 26 | €3 | | | 2 = €5 | ON | OFF | OFF | ON | ON |
| 27 | €5 | No Bonus | | | OFF | ON | OFF | ON | ON |
| 28 | €5 | | | 3 = €10 | ON | ON | OFF | ON | ON |
| 29 | €7.50 | No Bonus | | | OFF | OFF | ON | ON | ON |
| 30 | €7.50 | | | 2 = €10 | ON | OFF | ON | ON | ON |
| 31 | €10 | No Bonus | | | OFF | ON | ON | ON | ON |
| 32 | Free Play | | | | ON | ON | ON | ON | ON |

6.1.3. PRICE OF PLAY SETTINGS Austria-Czech-Denmark-Norway-Israel-France2

| | Price | Bonus | | | Switch 1 | | | | |
|----|-----------|----------|--------|---------|-----------|-----------|-----------|-----------|-----------|
| | | | | | Switch 1 | Switch 2 | Switch 3 | Switch 4 | Switch 5 |
| 1 | 1 | No Bonus | | | OFF | OFF | OFF | OFF | OFF |
| 2 | 1 | | | 11 = 10 | ON | OFF | OFF | OFF | OFF |
| 3 | 1 | | 6 = 5 | | OFF | ON | OFF | OFF | OFF |
| 4 | 2 | No Bonus | | | ON | ON | OFF | OFF | OFF |
| 5 | 2 | | | 6 = 10 | OFF | OFF | ON | OFF | OFF |
| 6 | 2 | | 3 = 5 | | ON | OFF | ON | OFF | OFF |
| 7 | 3 | No Bonus | | | OFF | ON | ON | OFF | OFF |
| 8 | 3 | | | 4 = 10 | ON | ON | ON | OFF | OFF |
| 9 | 3 | | 2 = 5 | | OFF | OFF | OFF | ON | OFF |
| 10 | 4 | No Bonus | | | ON | OFF | OFF | ON | OFF |
| 11 | 4 | | 3 = 10 | | OFF | ON | OFF | ON | OFF |
| 12 | 5 | No Bonus | | | ON | ON | OFF | ON | OFF |
| 13 | 5 | | | 3 = 10 | OFF | OFF | ON | ON | OFF |
| 14 | 6 | No Bonus | | | ON | OFF | ON | ON | OFF |
| 15 | 6 | | | 4 = 20 | OFF | ON | ON | ON | OFF |
| 16 | 8 | No Bonus | | | ON | ON | ON | ON | OFF |
| 17 | 10 | No Bonus | | | OFF | OFF | OFF | OFF | ON |
| 18 | 10 | | | 3 = 20 | ON | OFF | OFF | OFF | ON |
| 19 | 20 | No Bonus | | | OFF | ON | OFF | OFF | ON |
| 20 | 20 | | | 3 = 50 | ON | ON | OFF | OFF | ON |
| 21 | 30 | No Bonus | | | OFF | OFF | ON | OFF | ON |
| 22 | 30 | | | 2 = 50 | ON | OFF | ON | OFF | ON |
| 23 | 50 | No Bonus | | | OFF | ON | ON | OFF | ON |
| 24 | 50 | | | 3 = 100 | ON | ON | ON | OFF | ON |
| 32 | Free Play | | | | ON | ON | ON | ON | ON |

7. DESIGN RELATED PARTS

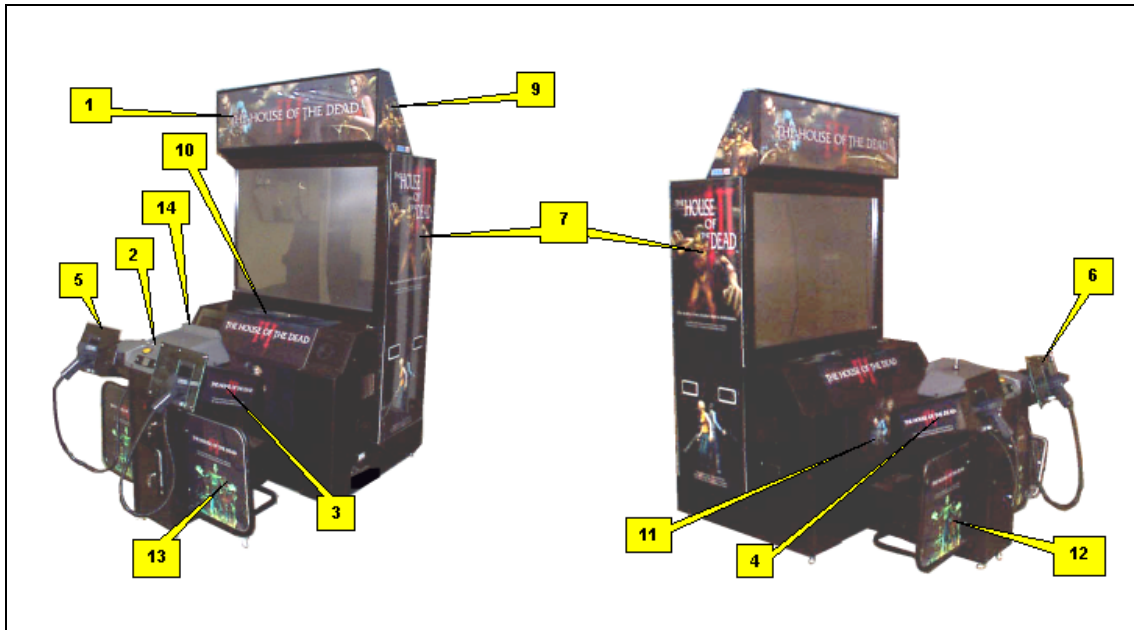

| Item | Part No. | Description |
|------|-----------------|--------------------------|
| 1 | HDT-0522UK | BILLBOARD PLATE |
| 2 | HDT-2001-B | BUTTON SHEET DX |
| 3 | HDT-2187UK | STICKER HOLSTER SIDE |
| 4 | HDT-2187UK | STICKER HOLSTER SIDE |
| 5 | HDT-2188UK | STICKER HOLSTER FRONT L |
| 6 | HDT-2198UK | STICKER HOLSTER FRONT R |
| 7 | HDT-0511UK | STICKER PTV SIDE |
| 8 | HDT-0524UK | STICKER BBD SIDE L |
| 9 | HDT-0525UK | STICKER BBD SIDE R |
| 10 | HDT-1062UK | STICKER LID UPPER |
| 11 | HDT-1072UK | STICKER LID LOWER |
| 12 | HDT-1151UK | GUARD PLATE L |
| 13 | HDT-1161UK | GUARD PLATE R |
| 14 | HDT-2001-C-01UK | STICKER CTRL PNL TOP ENG |

8. PARTS LIST

8.1. HDT-0000UK - TOP ASSY HOUSE OF THE DEAD3 DX

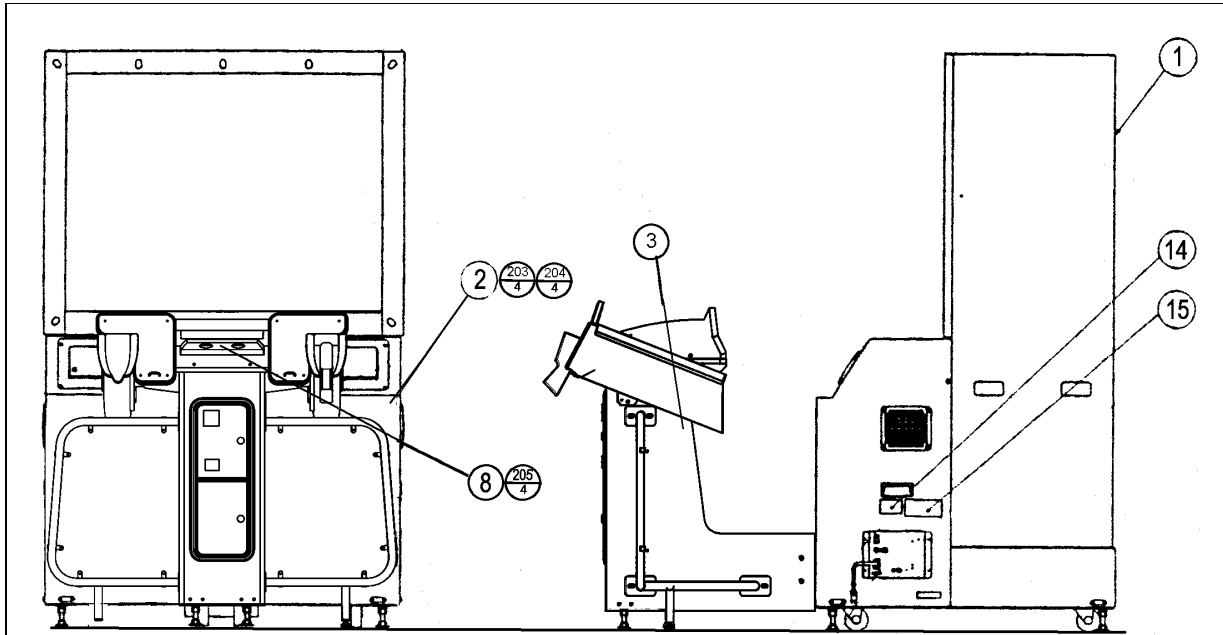

| Item | Component Part | Qty. | Description | Component Reference |
|------|----------------|------|-------------------------------|---------------------|
| 1 | HDT-0500UK | 1 | ASSY PTV | |
| 2 | HDT-1000UK | 1 | ASSY PTV CABI DX | |
| 3 | HDT-1100UK | 1 | ASSY CONTROLLER CABINET | |
| 8 | HOD-2003 | 1 | DENOMI PLATE | |
| 9 | SGM-4346 | 1 | POLY COVER 1200X1200X1300 | |
| 10 | SGM-4426 | 1 | POLY COVER 800X750X900 | |
| 14 | 421-7987-HDT-D | 1 | STICKER ELEC SPEC HDT DX | NEXT TO AC UNIT |
| 15 | 421-7988-91UK | 2 | STICKER SERIAL NUMBER UK | NEAR AC,CCT |
| 16 | LB1102 | 1 | STICKER DANGEROUS VOLTAGE | ON MAIN LID |
| 19 | 421-7020UK | 2 | STICKER CAUTION FORK | |
| 23 | HDT-INST-DX | 1 | ASSY INST KIT HDT DX | |
| 24 | PK0180 | 1 | PALLET CABI HOD DELUXE | |
| 25 | PK0319 | 1 | SLEEVE CTRL CABI HDT DX | |
| 26 | PK0178 | 1 | PALLET GUN CABI | |
| 27 | PK0320 | 1 | SLEEVE GUN CABI HDT DX | |
| 28 | PK0117 | 1 | PALLET PTV TOSH ZMB | |
| 29 | PK0321 | 1 | SLEEVE PTV HDT | |
| 30 | LB1046 | 1 | LABEL TESTED FOR ELEC. SAFETY | |
| 203 | 000-T00530-0B | 4 | M5X30 MSCR TH BLK | (2)-4 |
| 204 | 068-552016-0B | 4 | M5 WSHR 200D FLT BLK | (2)-4 |
| 205 | 000-T00416-0C | 4 | M4X16 MSCR TH CRM | (8)-4 |

8.2. HDT-0500UK - ASSY PTV

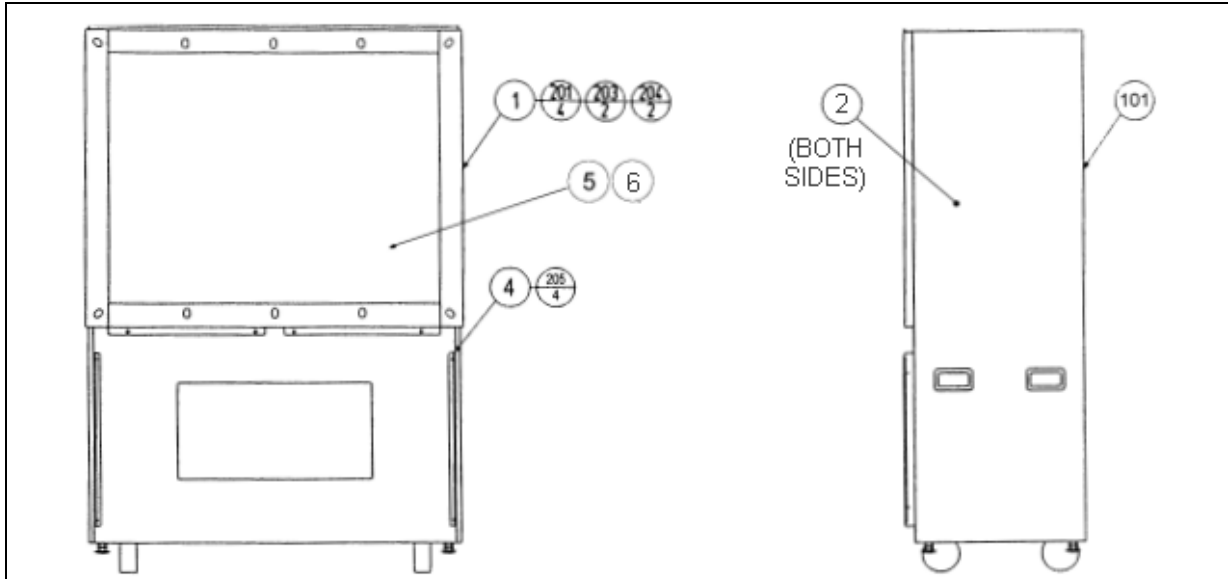

| Item | Component Part | Qty. | Description | Component Reference |
|------|----------------|------|------------------------------|---------------------|
| 1 | SPX-0530UK | 1 | ASSY MASK | |
| 2 | HDT-0511UK | 2 | STICKER PTV SIDE | |
| 4 | HOD-1101 | 2 | PTV HOLDER | |
| 5 | SPX-0532UK | 1 | PROTECT SCREEN PTV | (101)-1 |
| 6 | SPX-0533UK | 2 | RETAINING BRKT HORIZ PTV | (5)-2 |
| 101 | 200-5788-31 | 1 | PROJECTION DSPL T 50TYPE 31K | |
| 201 | 000-T00520-0B | 4 | M5X20 MSCR TH BLK | (1)-4 |
| 203 | 000-T00525-0B | 2 | M5X25 MSCR TH BLK | (1)-2 |
| 204 | 068-552016-0B | 2 | M5 WSHR 20OD FLT BLK | (1)-2 |
| 205 | 000-P00516-W | 4 | M5X16 MSCR PAN W/FS PAS | (4)-4 |
| 206 | 000-F00414 | 4 | M4X14 MSCR CSK PAS | (1)-4 |

8.3. HDT-0520UK - ASSY BILLBOARD DX

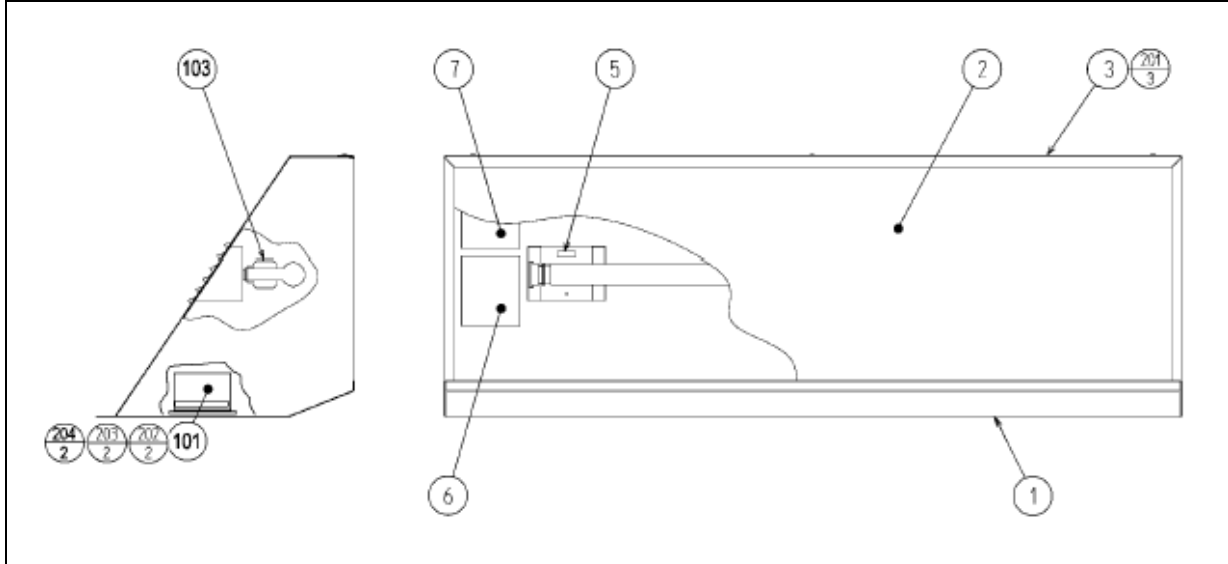

| Item | Component Part | Qty. | Description | Component Reference |
|------|-----------------|------|------------------------------|---------------------|
| 1 | POD-0521UK | 1 | BILLBOARD BOX | |
| 2 | HDT-0522UK | 1 | BILLBOARD PLATE | |
| 3 | POD-0523 | 1 | BILLBOARD SASH | |
| 5 | 421-7501-16 | 1 | STICKER 110V 30W | |
| 6 | LB1102 | 1 | STICKER DANGEROUS VOLTAGE | |
| 7 | LB1104 | 1 | STICKER CAUTION, HOT SURFACE | |
| 8 | HDT-0524UK | 1 | STICKER BBD SIDE L | |
| 9 | HDT-0525UK | 1 | STICKER BBD SIDE R | |
| 101 | 390-5695-30-AUK | 1 | FL TRAY 100V 30W | |
| 103 | LT1014 | 1 | TUBE FL 30W 36" DIA25mm | |
| 201 | 000-T00412-0B | 3 | M4X12 MSCR TH BLK | (3)-3 |
| 202 | 050-F00400 | 3 | M4 NUT FLG SER PAS | (101)-2,EARTH |
| 203 | 068-441616 | 2 | M4 WSHR 16OD FLT PAS | (101)-2 |
| 204 | 000-P00412 | 2 | M4X12 MSCR PAN PAS | (101)-2,TERRY CLIPS |
| 301 | NCR-60420UK | 1 | WIRE HARN FL | |

8.4. SPX-0530UK ASSY MASK

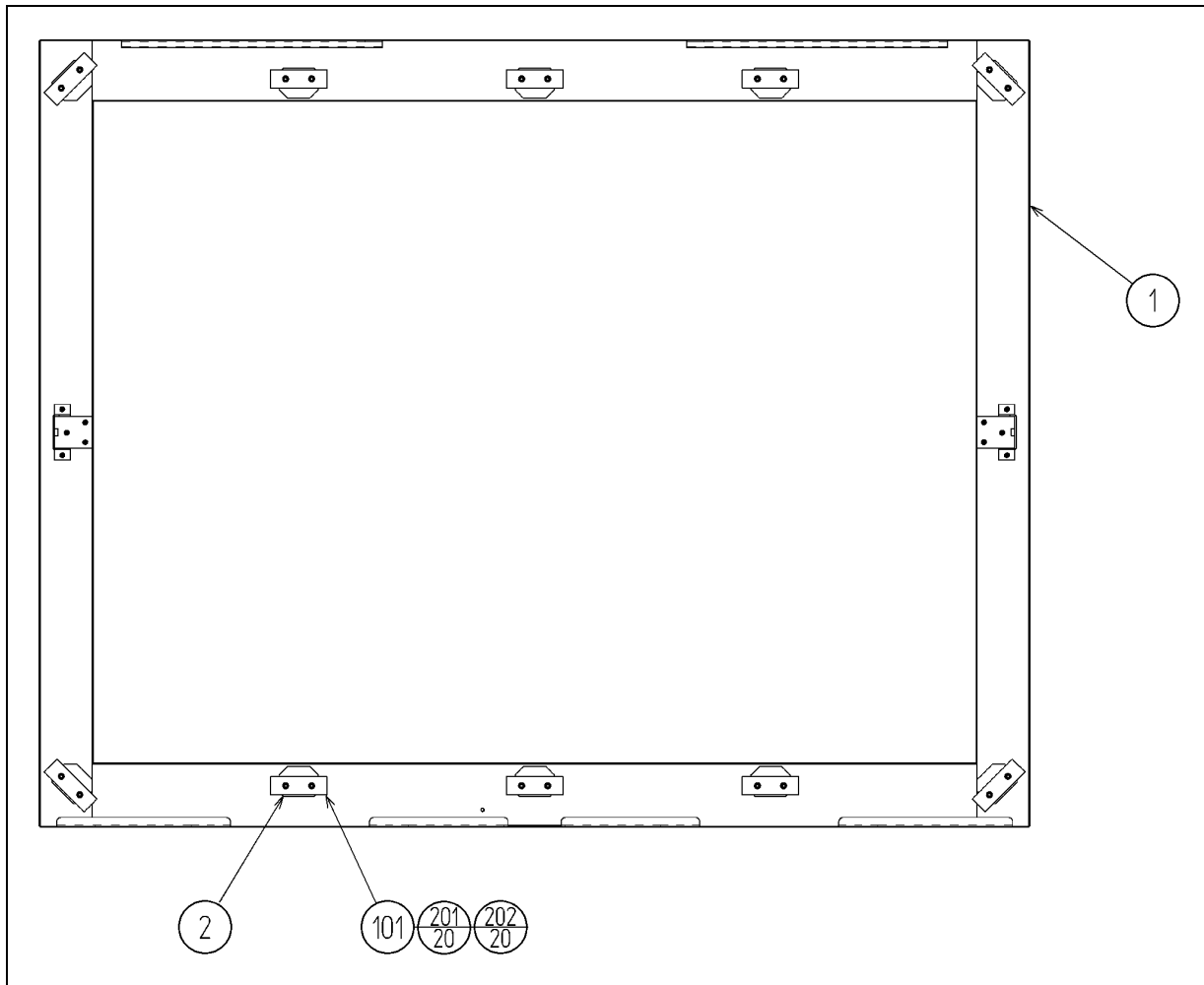

| ITEM | PART NUMBER | QTY | DESCRIPTION | COMPONENT REF |
|------|---------------|-----|------------------------------|-----------------|
| 1 | HOD-1151 | 1 | MASK BASE | |
| 2 | JPT-1082 | 10 | IR COVER | |
| 101 | 838-13145-02 | 10 | LED BD GUN SENSE HOD | |
| 201 | 050-U00300 | 20 | M3 NUT NYLOK PAS | (101)-20 |
| 202 | 068-330808-PN | 20 | M3 WSHR 8OD FLT NYLON | (101)-20 |
| 203 | 050-F00400 | 1 | M4 NUT FLG SER PAS | EARTH-1 |
| 301 | SPY-60024 | 7 | WIRE HARN MASK SHORT | |
| 302 | SPY-60025 | 2 | WIRE HARN MASK LONG | |
| 303 | SPY-60026 | 1 | WIRE HARN MASK INTO | |
| 304 | 600-9120-44K | 1 | WIRE HARN EARTH 1200MM M4/M4 | MASK TO AC BRKT |

8.5. HDT-1000UK ASSY PTV CABI DX

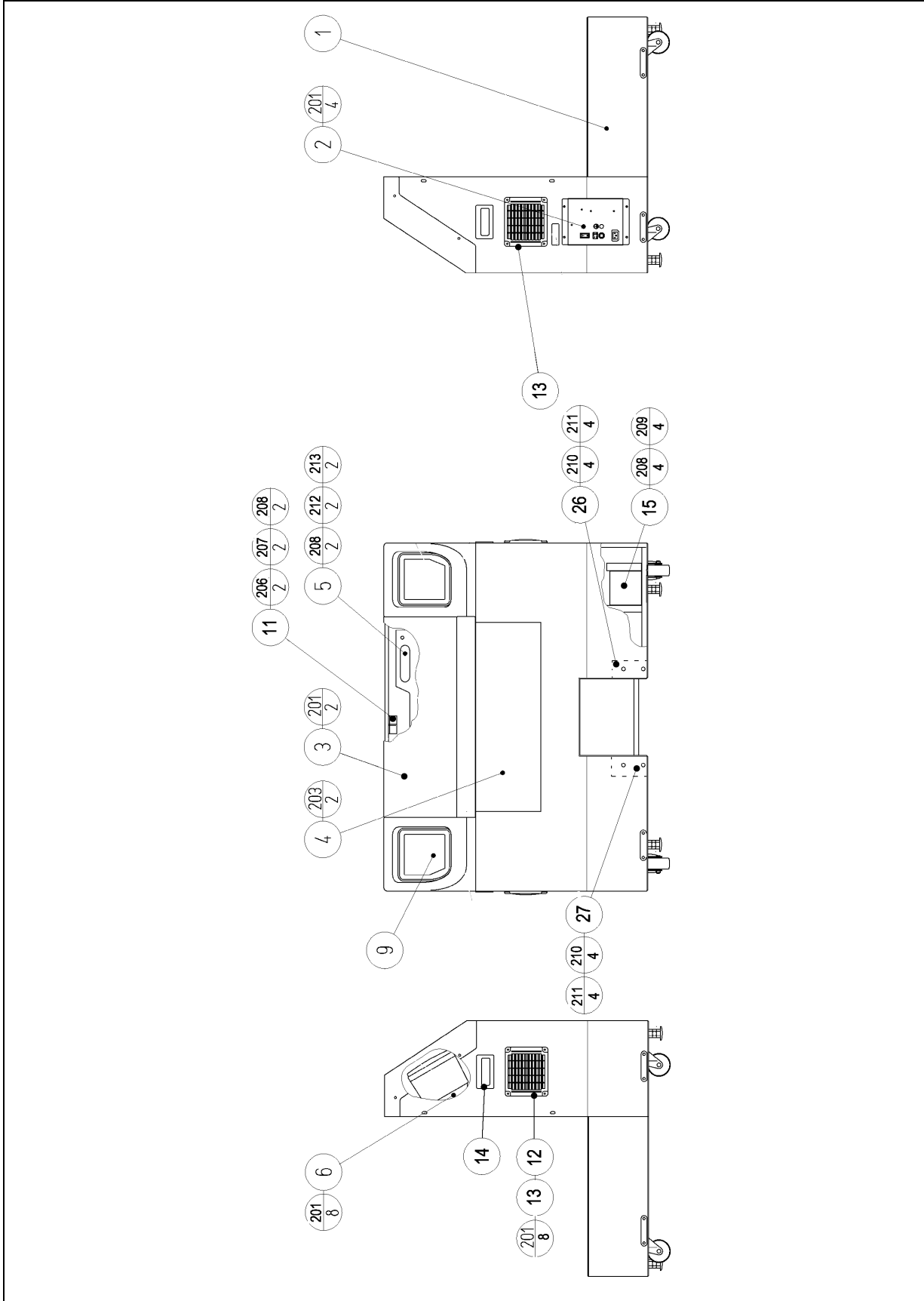

| Item | Component Part | Qty. | Description | Component Reference |
|------|----------------|------|-------------------------------|--------------------------|
| 1 | SPX-1002UK | 1 | PTV CABINET | |
| 2 | HOD-1020UK | 1 | ASSY AC UNIT UK | |
| 3 | HDT-1060UK | 1 | ASSY LID UPPER | |
| 4 | HDT-1070UK | 1 | ASSY LID LOWER | |
| 5 | HDT-4000UK | 1 | ASSY MAIN BD DX | |
| 6 | HOD-1070UK | 2 | ASSY SPEAKER UK | |
| 9 | SPX-1010UK | 2 | SPEAKER COVER | |
| 11 | HOD-1003 | 1 | LOCKING BRKT HOD | |
| 12 | HDT-1530UK | 1 | FAN UNIT DC UK | |
| 13 | 253-5460-01 | 2 | AIR VENT BLACK | |
| 14 | 253-5396-91 | 2 | CABINET HANDLE | |
| 15 | HDT-4200UK | 1 | ASSY PWR SPLY | |
| 26 | HOD-1007 | 1 | JOINT BRKT R | |
| 27 | HOD-1008 | 1 | JOINT BRKT L | |
| 101 | 354081 | 5 | TWIST LOK BHKL-450-4 | |
| 102 | 280-A00964-WX | 4 | ROUTER TWIST D09 SO6.4 WOOD X | |
| 201 | 000-T00420-0B | 22 | M4X20 MSCR TH BLK | (2)-4,(3)-2,(13)-8,(6)-8 |
| 203 | 000-P00420-W | 2 | M4X20 MSCR PAN W/FS PAS | (4)-2 |
| 206 | 000-P00425-W | 2 | M4X25 MSCR PAN W/FS PAS | (11)-2 |
| 207 | 050-F00400 | 2 | M4 NUT FLG SER PAS | (11)-2 |
| 208 | 068-441616-0B | 8 | M4 WSHR 16OD FLT BLK | (11)-2,(15)-4,(5)-2 |
| 209 | 000-P00430-W | 4 | M4X30 MSCR PAN W/FS PAS | (15)-4 |
| 210 | 030-000840-SB | 8 | M8X40 BLT W/S BLK | (26,27)-4 |
| 211 | 068-852216-0B | 4 | M8 WSHR 22OD FLT BLK | (26,27)-4 |
| 212 | 032-000530 | 2 | M5X30 BLT WING PAS | (5)-2 |
| 213 | 068-551616 | 2 | M5 WSHR 16OD FLT PAS | (5)-2 |
| 301 | SPY-60011UK | 1 | WIRE HARN TOWER EXT 1 | |

8.6. HDT-1060UK ASSY LID UPPER

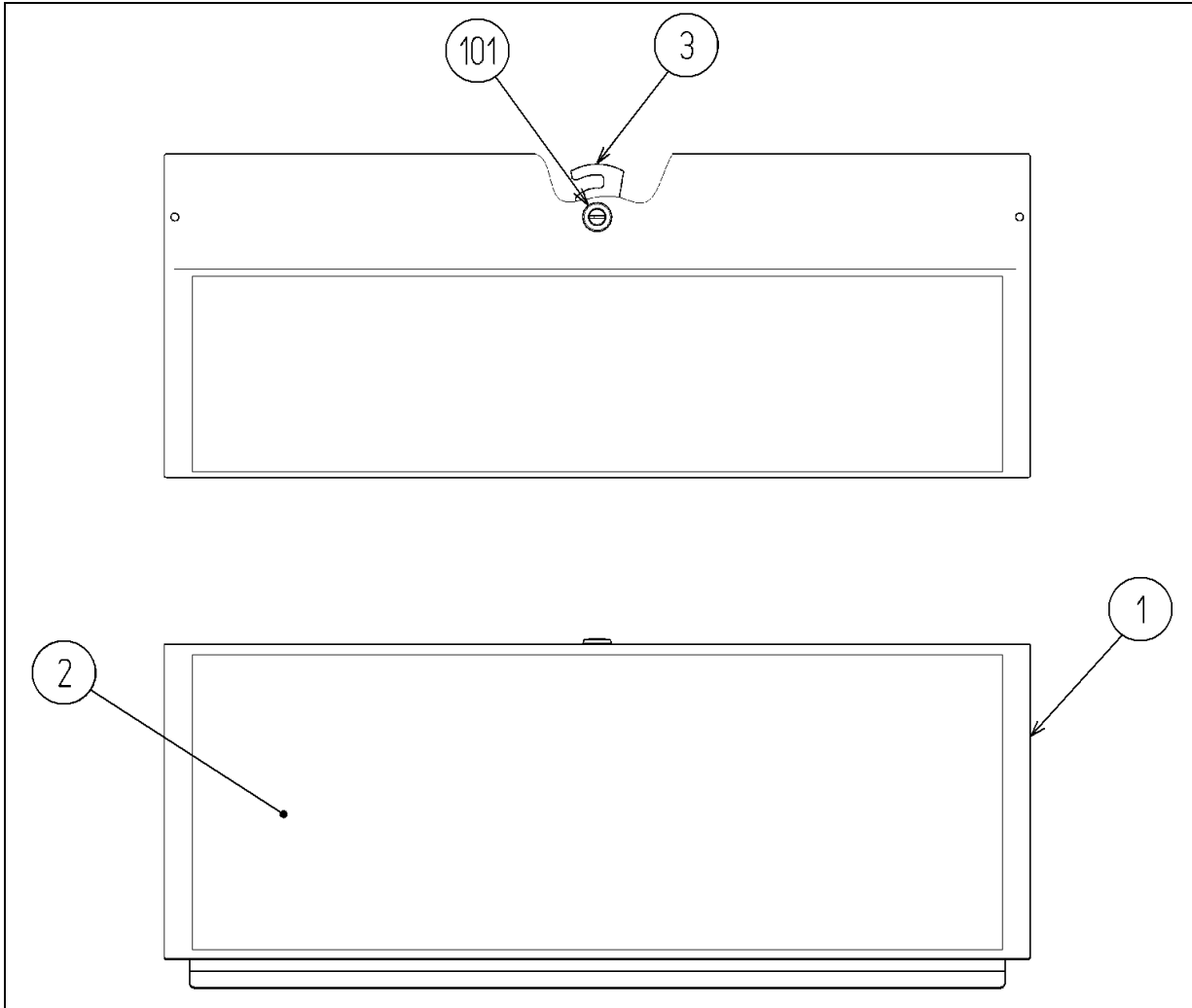

| Item | Component Part | Qty. | Description | Component Reference |
|------|----------------|------|-------------------|---------------------|
| 1 | HOD-1051-A | 1 | FRONT LID U BLANK | |
| 2 | HDT-1062UK | 1 | STICKER LID UPPER | |
| 3 | TH1015UK | 1 | LOCKING TONGUE UK | |
| 101 | 220-5575UK | 1 | LOCK | |

8.7. HDT-1070UK ASSY LID LOWER

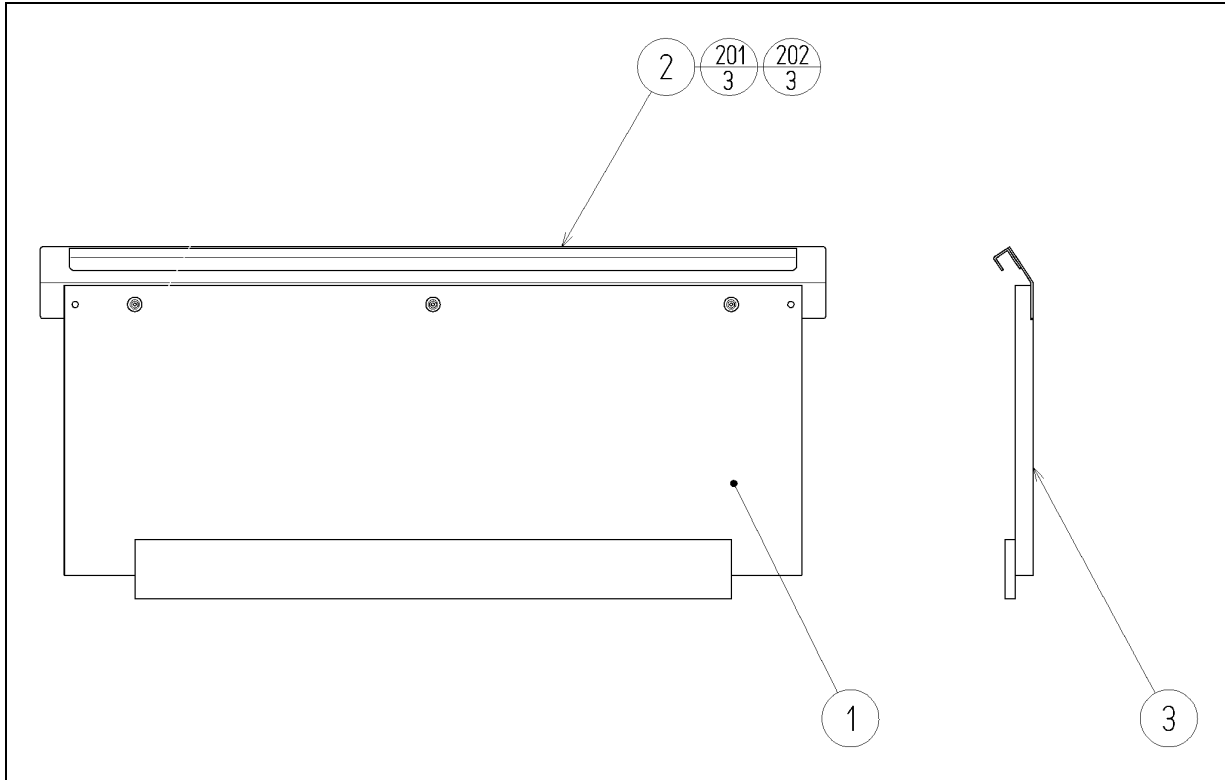

| Item | Component Part | Qty. | Description | Component Reference |
|------|----------------|------|------------------------|---------------------|
| 1 | HOD-1061-AUK | 1 | FRONT LID L BLANK | |
| 2 | HOD-1062-A | 1 | FRONT LID BRKT BLANK | |
| 3 | HDT-1072UK | 1 | STICKER LID LOWER | |
| 201 | 050-F00400 | 3 | M4 NUT FLG SER PAS | (2)-3 |
| 202 | 060-F00400-0B | 3 | M4 WSHR FORM A FLT BLK | (2)-3 |

8.8. HDT-1100UK ASSY CONTROLLER CABINET

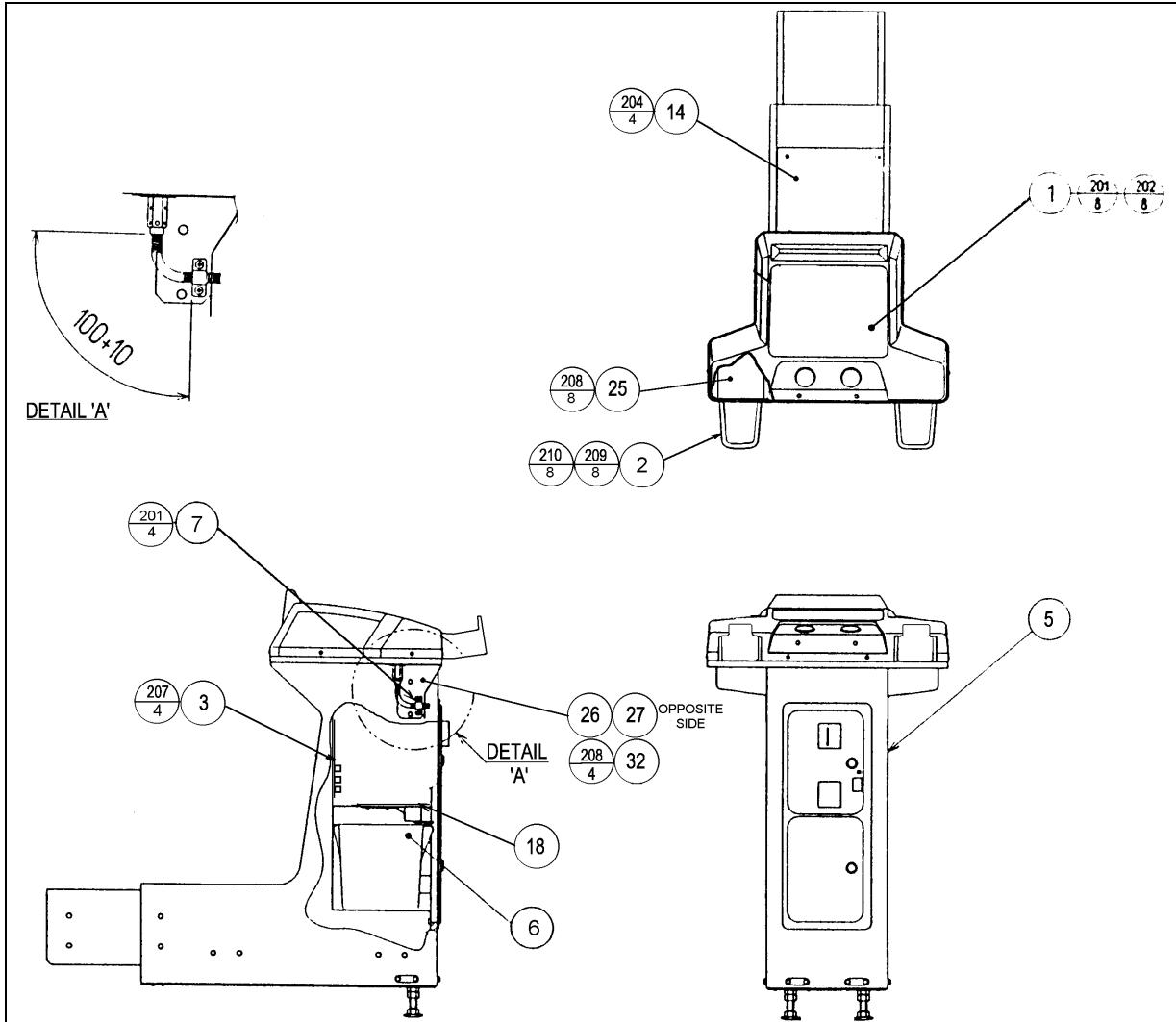

| Item | Component Part | Qty. | Description | Component Reference |
|------|----------------------------|------|----------------------|------------------------|
| 1 | HDT-2000UK | 1 | ASSY CTRL PANEL DX | |
| 2 | MAZ-1102 | 2 | HOLDER | |
| 3 | VTS-HOD-D | 1 | VTS BOARD HOD | |
| 5 | HOD-1302UK | 1 | GUN HOLDER CABI | |
| 6 | 253-5366 | 1 | CASH BOX | |
| 7 | JPT-3101 | 2 | TUBE CLAMP | |
| 12 | HDT-2100 | 2 | CONTROL UNIT | |
| 14 | HOD-1304 | 1 | JOINT PART LID | |
| 18 | DUT-0302UK | 1 | COIN PATH PLATE | |
| 25 | SPY-1106 | 2 | HOLDER BRKT | |
| 26 | HOD-1307-A | 1 | SIDE BRKT L BLANK | |
| 27 | HOD-1308-A | 1 | SIDE BRKT R BLANK | |
| 30 | HDT-1150UK | 1 | ASSY FENCE L | BUBBLE WRAP SEPARATELY |
| 31 | HDT-1160UK | 1 | ASSY FENCE R | BUBBLE WRAP SEPARATELY |
| 32 | 105-5216 | 2 | CHAIN BRKT | |
| 201 | 000-T00416-0B | 12 | M4X16 MSCR TH BLK | (1)-8,(7)-4 |
| 202 | 068-441616-0B | 8 | M4 WSHR 16OD FLT BLK | (1)-8 |

CONTINUED NEXT PAGE

CONTINUED FROM PREVIOUS PAGE

| ITEM | PART NUMBER | QTY | DESCRIPTION | COMPONENT REFERENCE |
|------|---------------|-----|--------------------------------|-----------------------------------|
| 203 | 008-T00430-0B | 8 | M4X30 TMP PRF TH BLK | (12)-8 |
| 204 | 000-T00440-0B | 4 | M4X40 MSCR TH BLK | (14)-4 |
| 207 | 000-P00420-W | 9 | M4X20 MSCR PAN W/FS PAS | (3)-4,(18)-5 |
| 208 | 030-000630-SB | 12 | M6X30 BLT W/S BLK | (25)-8,(26,27)-4 |
| 209 | 030-000616-SB | 8 | M6X16 BLT W/S BLK | (24)-8 |
| 210 | 060-F00600-0B | 8 | M6 WSHR FORM A FLT BLK | (24)-8 |
| 211 | 000-P00408-W | 2 | M4X8 MSCR PAN W/FS PAS | EARTHS-2 |
| 212 | 008-T00408-0C | 4 | M4X8 TMP PRF TH CRM | (32)-4 |
| 301 | SPY-60014UK | 1 | WIRE HARN TOWER EXT 2 | |
| 302 | SPY-60015 | 1 | WIRE HARN START EXT 2 | |
| 303 | HDT-60002UK | 1 | WIRE HARN EXT 2 | |
| 304 | 600-9220-44K | 1 | WIRE HARN EARTH 2200mm M4/M4 K | LH GUN HOLDER TO AC BRKT |
| 305 | 600-9040-44K | 1 | WIRE HARN EARTH 400mm M4/M4 K | LH GUN HOLDER TO RH GUN HOLDER |

8.9. HDT-1150UK ASSY FENCE L

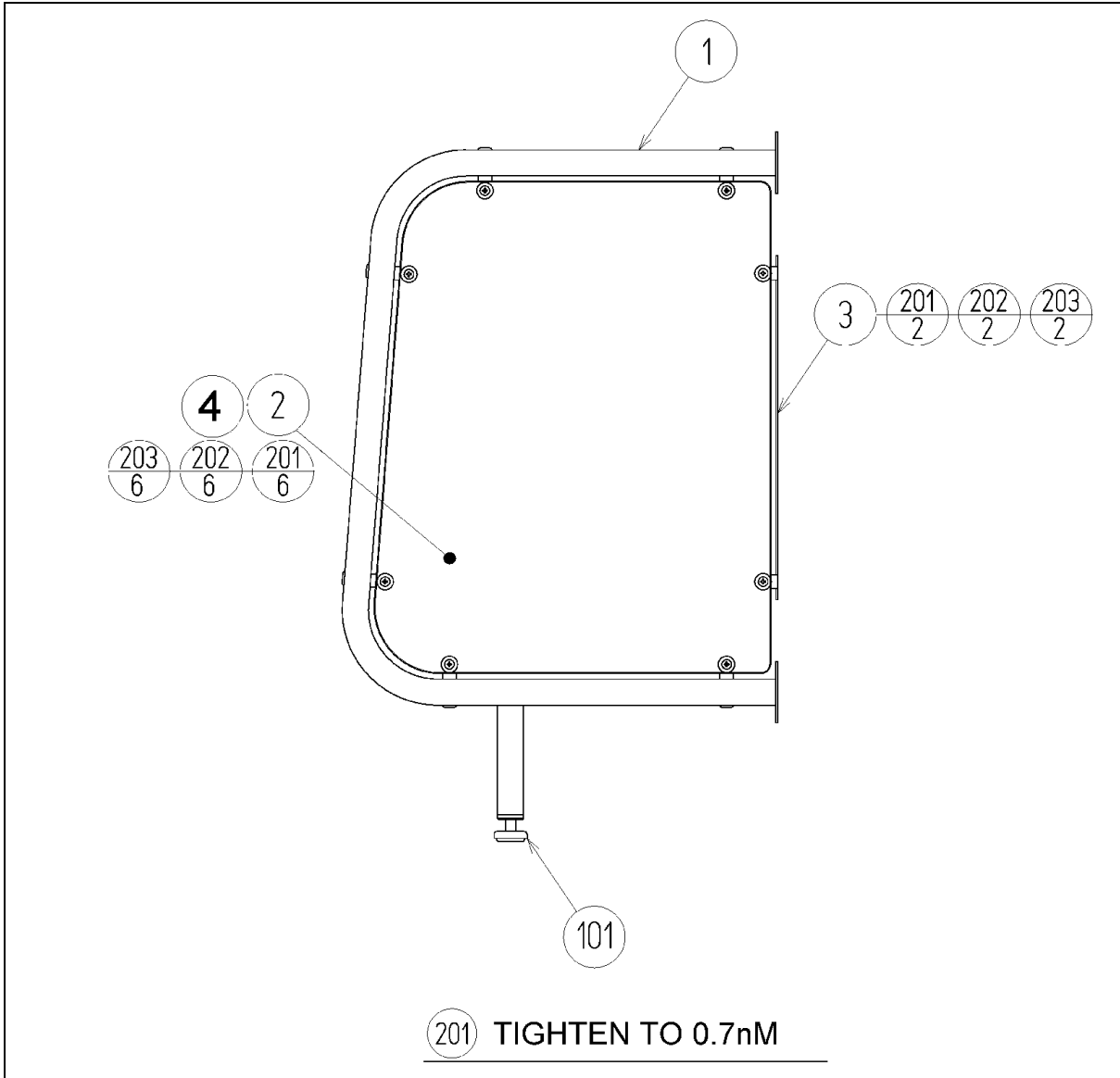

| Item | Component Part | Qty. | Description | Component Reference |
|------|----------------|------|-------------------------|---------------------|
| 1 | HOD-1351 | 1 | PIPE L | |
| 2 | HDT-1151UK | 1 | GUARD PLATE L | |
| 3 | HOD-0004UK | 2 | PLATE HOLDER | |
| 4 | HDT-1152UK | 1 | PLATE GUARD BASE | |
| 101 | 601-6076-OBUK | 1 | LEG ADJUSTER 32MM BLACK | |
| 201 | 000-T00412-0B | 8 | M4X12 MSCR TH BLK | (2)-6,(3)-2 |
| 202 | 068-441616-0B | 8 | M4 WSHR 16OD FLT BLK | (2)-6,(3)-2 |
| 203 | 050-C00400-3B | 8 | M4 NUT DOME TYPE 3 BLK | (2)-6,(3)-3 |

8.10. HDT-1160UK ASSY FENCE R

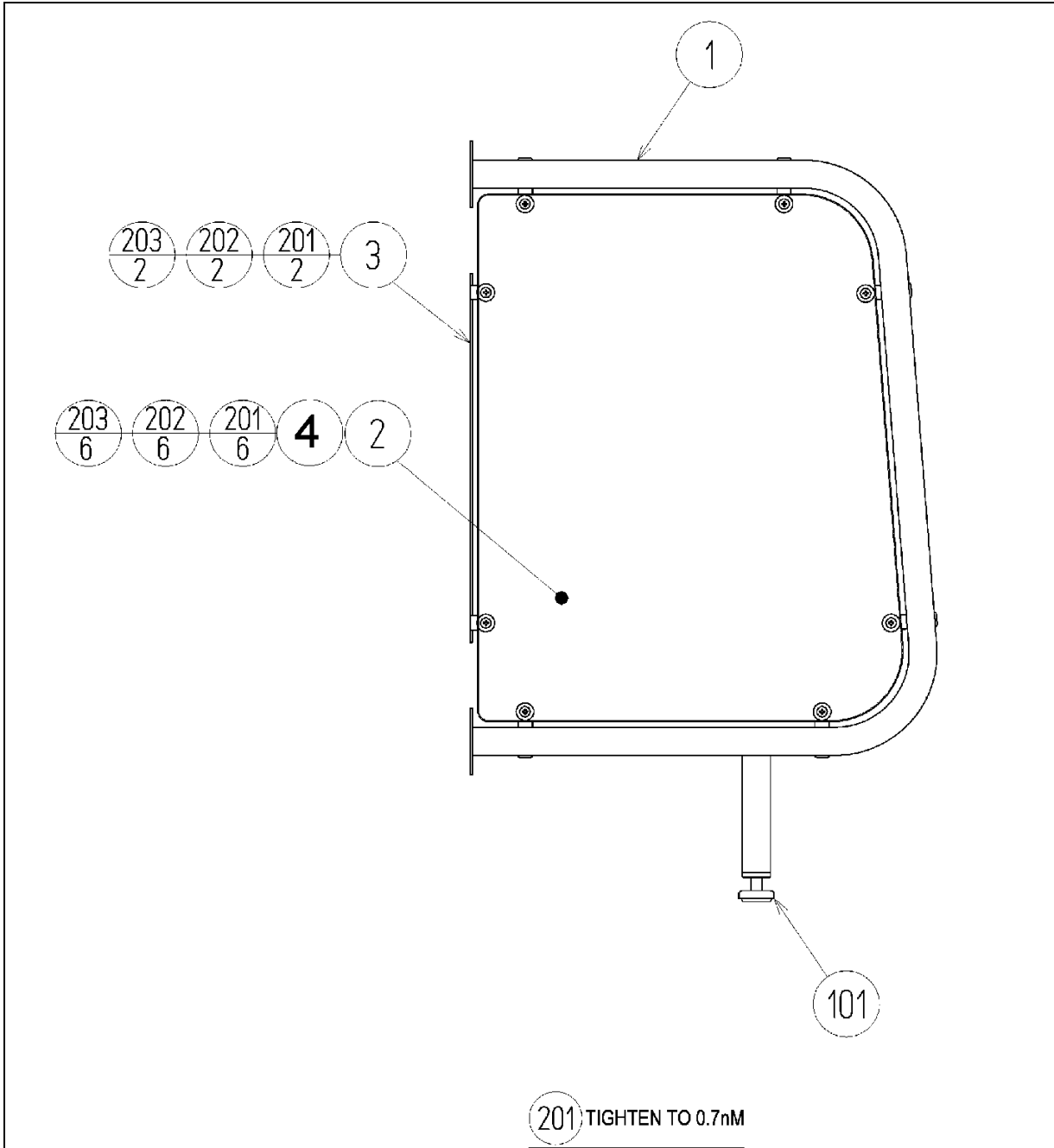

| Item | Component Part | Qty. | Description | Component Reference |
|------|----------------|------|-------------------------|---------------------|
| 1 | HOD-1361 | 1 | PIPE R | |
| 2 | HDT-1161UK | 1 | GUARD PLATE R | |
| 3 | HOD-0004UK | 2 | PLATE HOLDER | |
| 4 | HDT-1162UK | 1 | PLATE GUARD BASE | |
| 101 | 601-6076-OBUK | 1 | LEG ADJUSTER 32MM BLACK | |
| 201 | 000-T00412-0B | 8 | M4X12 MSCR TH BLK | (2)-6,(3)-2 |
| 202 | 068-441616-0B | 8 | M4 WSHR 16OD FLT BLK | (2)-6,(3)-2 |
| 203 | 050-C00400-3B | 8 | M4 NUT DOME TYPE 3 BLK | (2)-6,(3)-2 |

8.11. HDT-2000UK ASSY CTRL PANEL DX

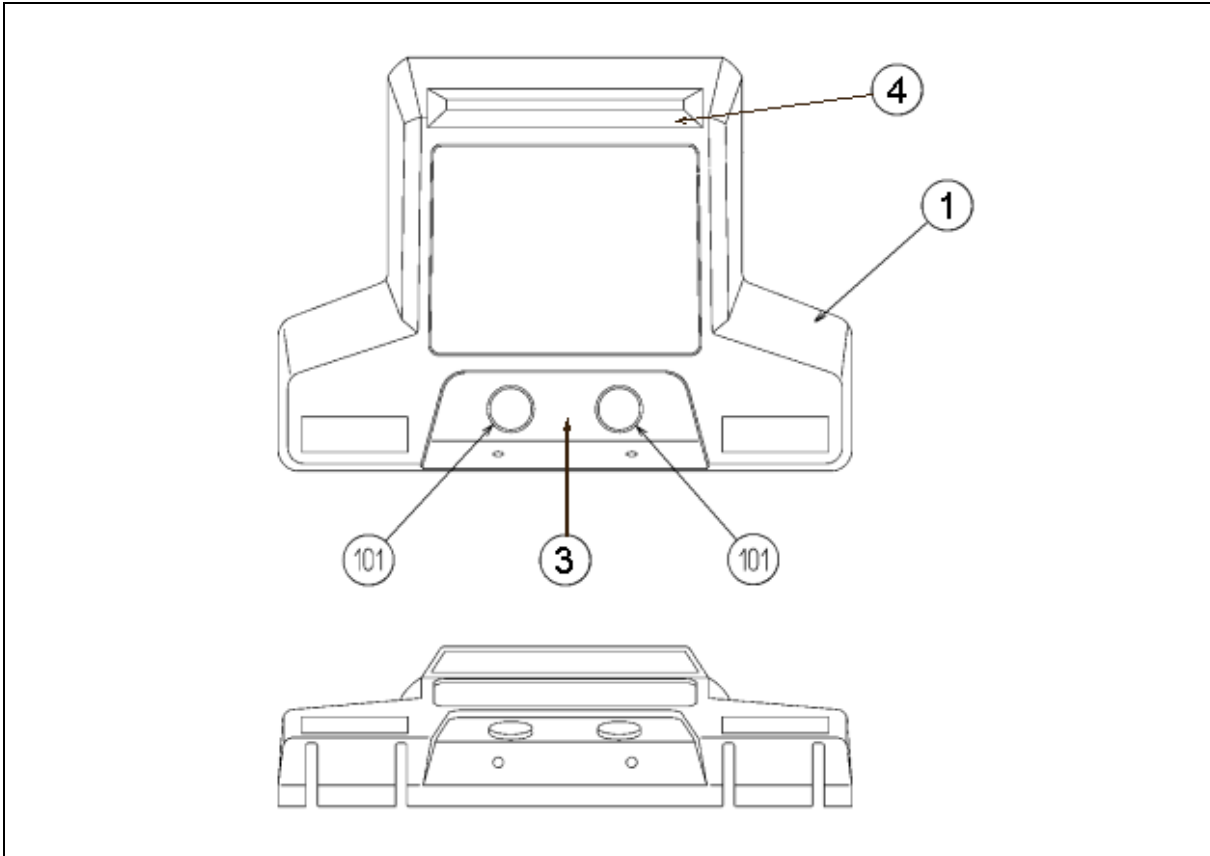

| Item | Component Part | Qty. | Description | Component Reference |
|------|-----------------|------|-----------------------------|---------------------|
| 1 | HDT-2001-A-W | 1 | CTRL PNL BLANK W/NUT PLATES | |
| 3 | HDT-2001-B | 1 | BUTTON SHEET DX | |
| 4 | HDT-2001-C-01UK | 1 | STICKER CTRL PNL TOP ENG | |
| 101 | 509-5712-01S | 2 | SW PB W/L 6V YELLOW | |
| 301 | HOD-60020 | 1 | WIRE HARN CONTROL PANEL | |

8.12. HDT-2100 CONTROL UNIT

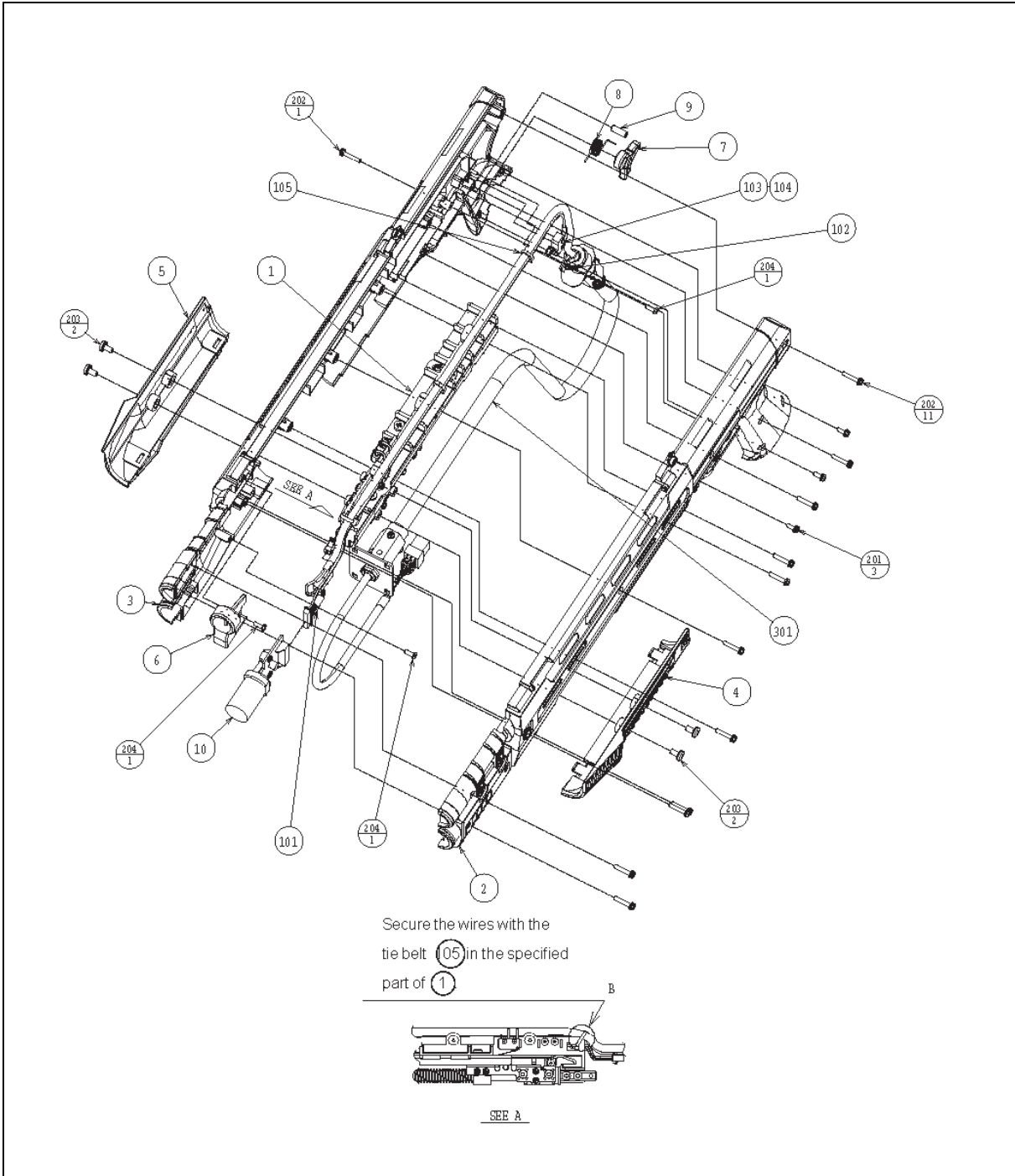

| ITEM NO. | PART NO. | DESCRIPTION NOTE |
|----------|--------------|-------------------------------|
| 1 | HDT-2120 | ASSY SLIDE MECHA |
| 2 | HDT-2101 | COVER L |
| 3 | HDT-2102 | COVER R |
| 4 | HDT-2103 | SLIDE GRIP L |
| 5 | HDT-2104 | SLIDE GRIP R |
| 6 | HDT-2105 | FRONT SIGHT |
| 7 | HDT-2106 | TRIGGER |
| 8 | HDT-2107 | TRIGGER SPRING |
| 9 | HDT-2108 | STOPPER PIN |
| 10 | JPT-2030 | SENSOR UNIT |
| 101 | 280-5124-02 | NYLON CLAMP NK02 |
| 102 | 280-5124-03 | NYLON CLAMP NK03 |
| 103 | 310-5029-D20 | SUMITUBE F D 20MM |
| 104 | 509-5080 | SW MICRO TYPE (SS-5GL2) |
| 105 | 601-0460 | PLASTIC TIE BELT 100 MM |
| 201 | FAS-000092 | M SCR PH W/SMALL FS BLK M3~8 |
| 202 | FAS-000093 | M SCR PH W/SMALL FS BLK M3~16 |
| 203 | FAS-000094 | M SCR BIND H W/TOOTH BLK M4~8 |
| 204 | FAS-120023 | TAP SCR P-TITE PH 3~8 |
| 301 | HDT-60007 | WH CONTROL UNIT |

8.13. SENSOR UNIT (JPT-2030)

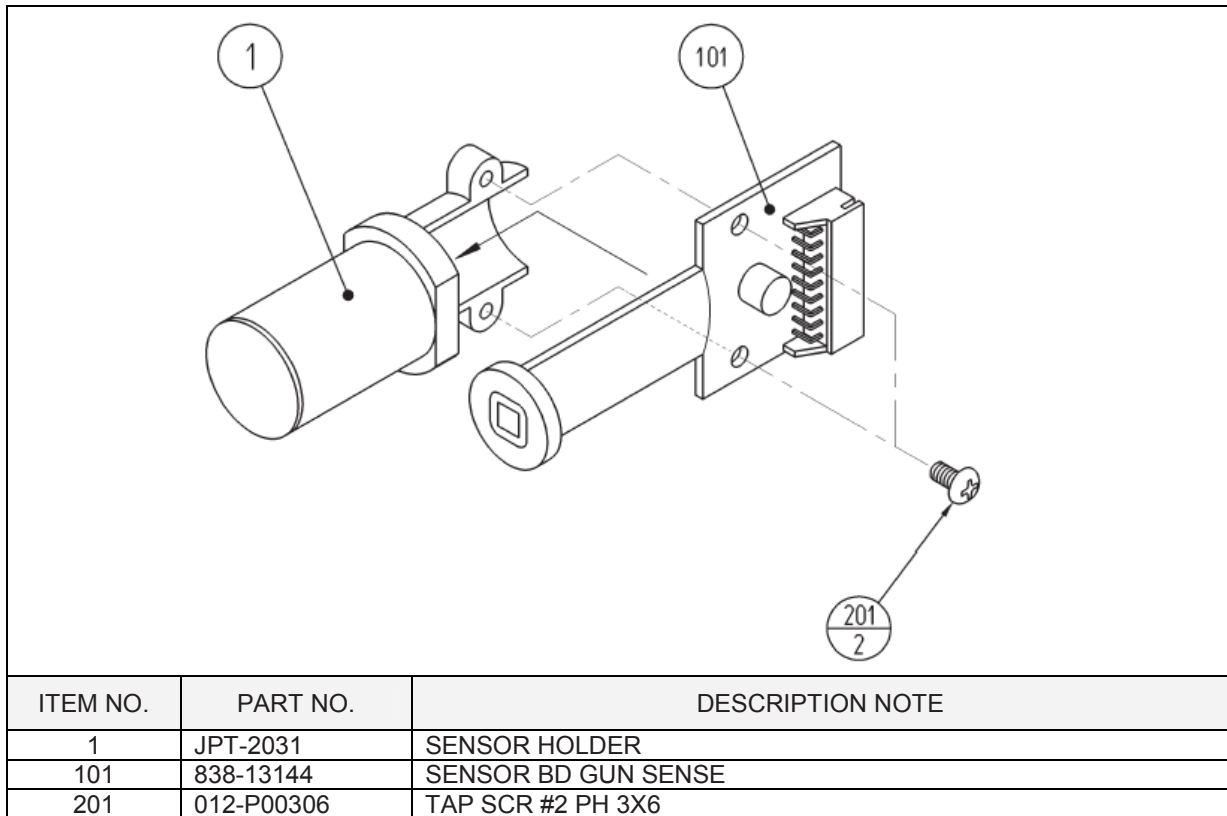

8.14. HDT-2180UKASSY GUN HOLDER W/TETHER L

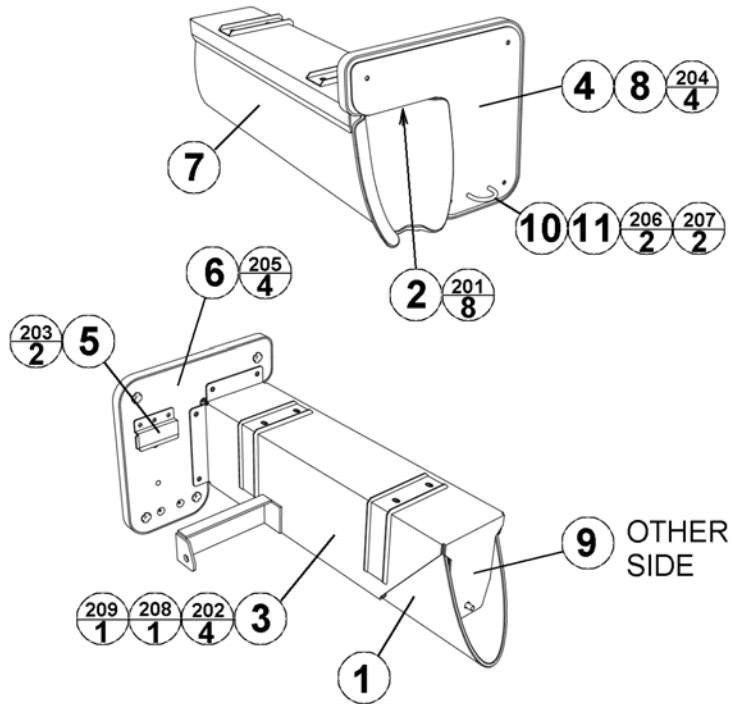

| Item | Component Part | Description | Qty. | Component Reference |
|------|----------------|-------------------------|------|---------------------|
| 1 | HDT-2181UK | GUN HOLSTER | 1 | |
| 2 | HDT-2182UK | GUN HOLSTER SUPPORT | 1 | |
| 3 | HDT-2183UK | GUN HOLSTER BRKT L | 1 | |
| 4 | HDT-2184UK | PLATE HOLDER | 1 | |
| 5 | HDT-2185UK | PLATE HOLDER BRKT L | 1 | |
| 6 | HDT-2186UK | MDF HOLDER BASE L | 1 | |
| 7 | HDT-2187UK | STICKER HOLSTER SIDE | 1 | (1)-1 |
| 8 | HDT-2188UK | STICKER HOLSTER FRONT L | 1 | (4)-1 |
| 9 | HDT-2197UK | GUN CUSHION | 1 | (2)-1 |
| 10 | RTS-0306 | MIC BOX U-BOLT | 1 | (4)-1 |
| 11 | HDT-2199UK | GUN TETHER DX | 1 | |
| 201 | 000-T00512-0B | M5X12 MSCR TH BLK | 8 | (2)-8 |
| 202 | 008-P00620-0B | M6X20 TMP PRF TH BLK | 4 | (3)-4 |
| 203 | 000-P00416-WB | M4X16 MSCR PAN W/FS BLK | 2 | (5)-2 |
| 204 | 008-T00416-0B | M4X16 TMP PRF TH BLK | 4 | (4)-4 |
| 205 | 030-000616-0B | M6X16 BLT BLK | 4 | (6)-4 |
| 206 | 060-F00300 | M3 WSHR FORM A FLT PAS | 2 | (10)-2 |
| 207 | 050-U00300 | M3 NUT NYLOK PAS | 2 | (10)-2 |
| 208 | 050-U00600 | M6 NUT NYLOK PAS | 1 | (3)-1 |
| 209 | 068-651616-0B | M6 WSHR 16OD FLT BLK | 1 | (3)-1 |

8.15. HDT-2190UKASSY GUN HOLDER W/TETHER R

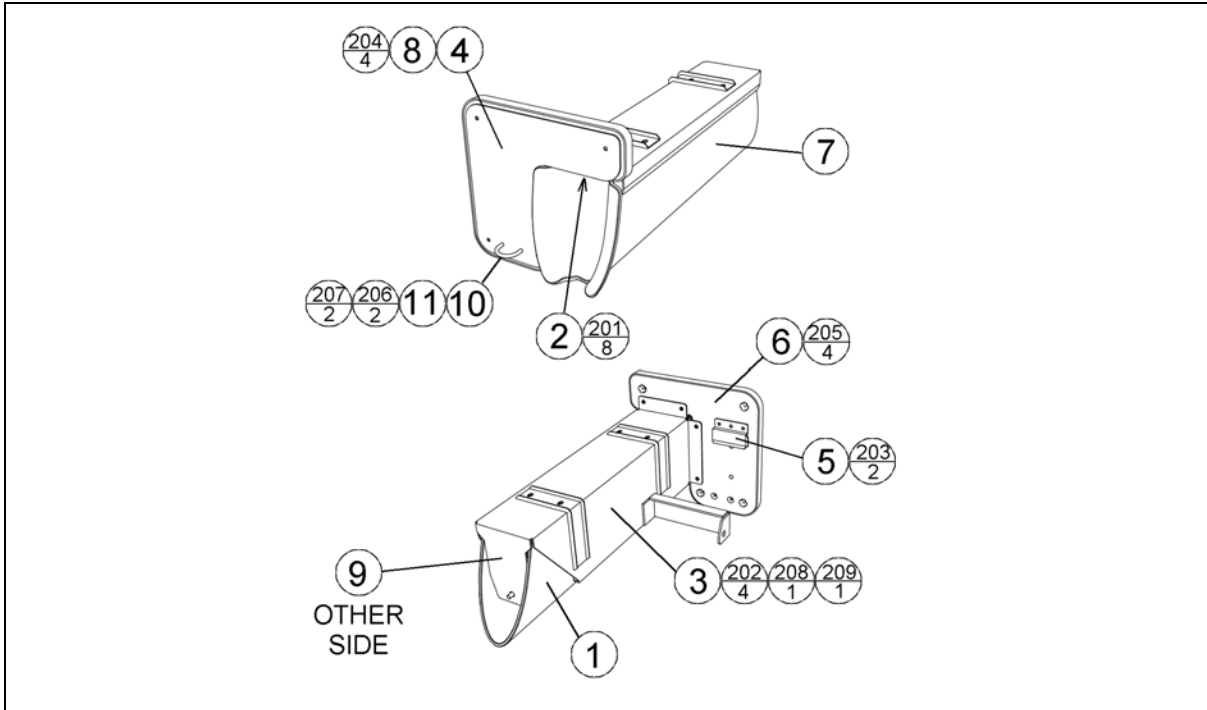

| Item | Component Part | Description | Qty. | Component Reference |
|------|----------------|-------------------------|------|---------------------|
| 1 | HDT-2181UK | GUN HOLSTER | 1 | |
| 2 | HDT-2182UK | GUN HOLSTER SUPPORT | 1 | |
| 3 | HDT-2193UK | GUN HOLSTER BRKT R | 1 | |
| 4 | HDT-2184UK | PLATE HOLDER | 1 | |
| 5 | HDT-2195UK | PLATE HOLDER BRKT R | 1 | |
| 6 | HDT-2196UK | MDF HOLDER BASE R | 1 | |
| 7 | HDT-2187UK | STICKER HOLSTER SIDE | 1 | (1)-1 |
| 8 | HDT-2198UK | STICKER HOLSTER FRONT R | 1 | (4)-1 |
| 9 | HDT-2197UK | GUN CUSHION | 1 | (2)-1 |
| 10 | RTS-0306 | MIC BOX U-BOLT | 1 | (4)-1 |
| 11 | HDT-2199UK | GUN TETHER DX | 1 | |
| 201 | 000-T00512-0B | M5X12 MSCR TH BLK | 8 | (2)-8 |
| 202 | 008-P00620-0B | M6X20 TMP PRF TH BLK | 4 | (3)-4 |
| 203 | 000-P00416-WB | M4X16 MSCR PAN W/FS BLK | 2 | (5)-2 |
| 204 | 008-T00416-0B | M4X16 TMP PRF TH BLK | 4 | (4)-4 |
| 205 | 030-000616-0B | M6X16 BLT BLK | 4 | (6)-4 |
| 206 | 060-F00300 | M3 WSHR FORM A FLT PAS | 2 | (10)-2 |
| 207 | 050-U00300 | M3 NUT NYLOK PAS | 2 | (10)-2 |
| 208 | 050-U00600 | M6 NUT NYLOK PAS | 1 | (3)-1 |
| 209 | 068-651616-0B | M6 WSHR 16OD FLT BLK | 1 | (3)-1 |

8.16. HDT-4000UK ASSY MAIN BD DX

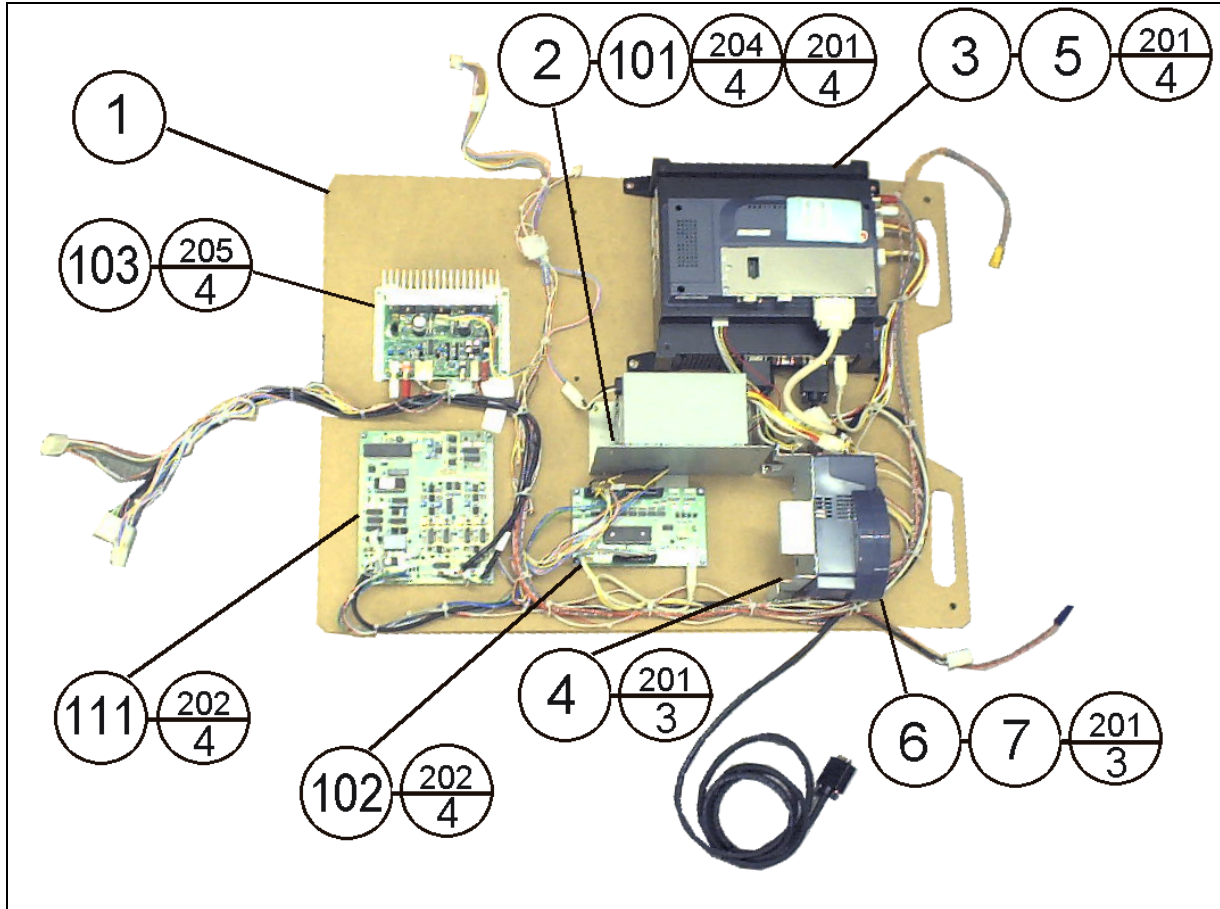

| Item | Component Part | Qty. | Description | Component Reference |
|------|----------------|------|--------------------------------|---------------------|
| 1 | SPY-4001UK | 1 | WOODEN BASE MAIN BD DX | |
| 2 | TMB-4003 | 1 | SW REGU BRKT | |
| 3 | 843-0001D-12 | 1 | ASSY CASE BOX COM NAO DIMM EXP | |
| 4 | 105-5435 | 1 | GD DRIVE BRKT STD | |
| 5 | LB1101 | 1 | LABEL WARNING BATTERY | |
| 6 | 610-0617 | 1 | GD-ROM DRIVE UNIT NAOMI | |
| 7 | 610-0652-0001 | 1 | GD SOFT HDT | |
| 8 | LB1111 | 1 | STICKER PLEASE RECYCLE | |
| 9 | 253-5508-0348 | 1 | KEY CHIP | |
| 101 | 400-5443 | 1 | SW REGU FOR CHIHIRO | |
| 102 | 837-13551-92 | 1 | I/O CONTROL BD FOR JVS | |
| 103 | 838-13616 | 1 | AUDIO POWER AMP 2CH | |
| 104 | 280-A00964-WX | 7 | ROUTER TWIST D09 SO6.4 WOOD X | |
| 105 | 354081 | 6 | TWIST LOK BHKL-450-4 | |
| 106 | 354083 | 6 | (A) TWIST N LOK BHKL-750-4 | |
| 110 | 838-13143-08 | 1 | IC BD GUN SENSE SPY | |

CONTINUED ON NEXT PAGE

CONTINUED FROM PREVIOUS PAGE

| ITEM | PART NUMBER | QTY | DESCRIPTION | COMPONENT REFERENCE |
|------|---------------|-----|------------------------------|------------------------------------|
| 201 | 000-P00416-W | 11 | M4X16 MSCR PAN W/FS PAS | (2)-4,(3)-4,(4)-3 (CHIIRO FIXINGS) |
| 202 | 012-P00325 | 8 | N4X1" S/TAP PAN PAS | (102)-4,(110)-4 |
| 204 | 000-P00408-W | 4 | M4X8 MSCR PAN W/FS PAS | (101)-4 |
| 205 | 012-P03512-F | 4 | N6X1/2" S/TAP FLG PAS | (103)-4 |
| 206 | 012-P00410-F | 4 | N8X3/8" S/TAP FLG PAS | (6)-4 |
| 301 | SPY-60010UK | 1 | WIRE HARN HIGH FRQNCY JUMPER | CN1 ON IC BD GUN SENSE SPY |
| 302 | 600-7159-039 | 1 | WIRE HARN JVS PWR 039CM | |
| 303 | SPY-60009 | 1 | WIRE HARN CTRL BD RECIEVER | |
| 304 | HDT-60006UK | 1 | WIRE HARN AC MAIN BD | |
| 305 | SMB-60013 | 1 | WIRE HARN SPEAKER L | |
| 306 | SMB-60014 | 1 | WIRE HARN SPEAKER R | |
| 307 | SPY-60005 | 1 | WIRE HARN AUDIO L | |
| 308 | SPY-60006 | 1 | WIRE HARN AUDIO R | |
| 309 | HDT-60003UK | 1 | WIRE HARN SW CONTROL | |
| 310 | 600-7009-2500 | 1 | ASSY RGB CA D-SUB 15P 2500MM | |
| 311 | HDT-60100UK | 1 | WH POWER GD ROM | |
| 313 | 600-7141-100 | 1 | CABLE JVS TYPE A-B 100CM | |
| 315 | 600-7242-250 | 1 | CABLE SCSI ST-L TYPE1 250MM | |

8.17. HDT-4200UK ASSY PWR SPLY

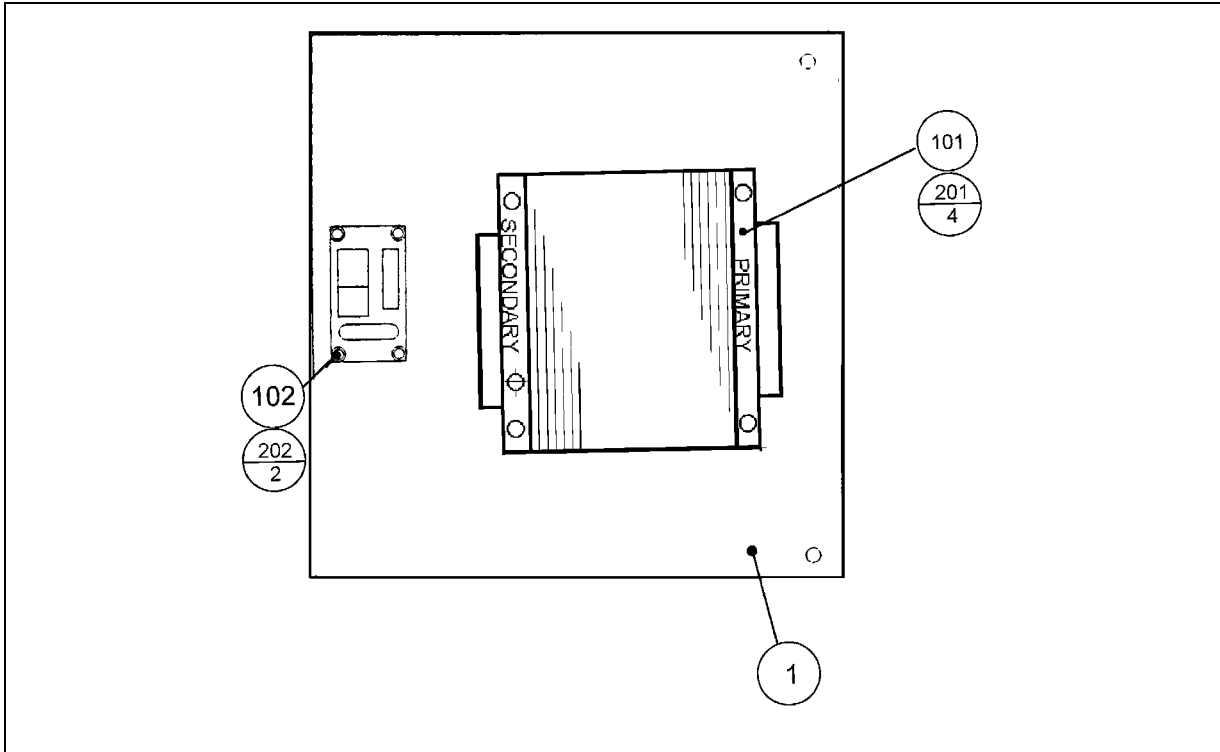

| Item | Component Part | Qty. | Description | Component Reference |
|------|----------------|------|-------------------------|---------------------|
| 1 | HOD-4101UK | 1 | WOODEN BASE PWR SPLY | |
| 101 | 560-5422UK | 1 | XFMR NOB | |
| 102 | 838-11856CE-02 | 1 | CONN BD W/FUSE 6.3A CE | |
| 201 | 000-P00416-W | 4 | M4X16 MSCR PAN W/FS PAS | (XFMR)-4 |
| 202 | 012-P00325 | 2 | N4X1" S/TAP PAN PAS | (CONN BD)-2 |
| 301 | HDT-60005UK | 1 | WIRE HARN AC-CONN BD | |

8.18. HDT-INST-DX ASSY INST KIT HDT DX

| Item | Component Part | Qty. | Description | Component Reference |
|------|----------------|------|-------------------------------|-----------------------------------|
| 1 | HDT-0520UK | 1 | ASSY BILLBOARD DX | |
| 2 | HOD-0006 | 2 | L BRKT | |
| 4 | 440-CS0186UK | 1 | STICKER C EPILEPSY MULTI | |
| 6 | HDT-2180UK | 1 | ASSY GUN HOLDER W/TETHER L | |
| 7 | HDT-2190UK | 1 | ASSY GUN HOLDER W/TETHER R | |
| 22 | PK0318 | 1 | CARTON BOX INST KIT HDT DX | |
| 23 | SAECE-XXX | 1 | DECLARATION OF CONFORMITY | DECLARATION OF CONFORMITY HDTD |
| 24 | HDT-2002UK | 1 | INST PLATE HDT DX MULTI | |
| 101 | 290094 | 0.08 | WRAP BUBBLE (SM) 600MM X 100M | |
| 201 | 030-000850-SB | 4 | M8X50 BLT W/S BLK | FENCE L+R-2EA |
| 202 | 030-000830-SB | 8 | M8X30 BLT W/S BLK | FENCE L+R-4EA |
| 203 | 029-F00625-0B | 4 | M6X25 SKT CSK BLK | (6)-2, (7)-2 |
| 205 | 000-T00420-0B | 4 | M4X20 MSCR TH BLK | FENCE L+R-2EA |
| 206 | 068-441616-0B | 4 | M4 WSHR 16OD FLT BLK | FENCE L+R-2EA |
| 207 | 030-000840-SB | 8 | M8X40 BLT W/S BLK | (2)-8 |
| 208 | 068-852216-0B | 24 | M8 WSHR 22OD FLT BLK | (2)-8, FENCE L+R-6EA, (CABI)-4 |
| 209 | 030-000860-0B | 4 | M8X60 BLT BLK | (CABI)-4 |
| 401 | 420-6620UK | 1 | SERVICE MANUAL GD ROM SYSTEM | |
| 402 | OS1019 | 2 | SELF SEAL BAG 9X12.3/4 | |
| 403 | 420-6742-01UK | 1 | SERVICE MANUAL HDT DX | |
| 405 | 390-5160 | 1 | LAMP WG B TYPE 6V 3W (C2R) | |
| 406 | 509-5080 | 2 | SW MICRO TYPE (SS-5GL2) | |
| 413 | 514-5078-5000 | 1 | FUSE 5X20 CERAMIC SB 5000mA | |

8.19. HOD-1020UK ASSY AC UNIT

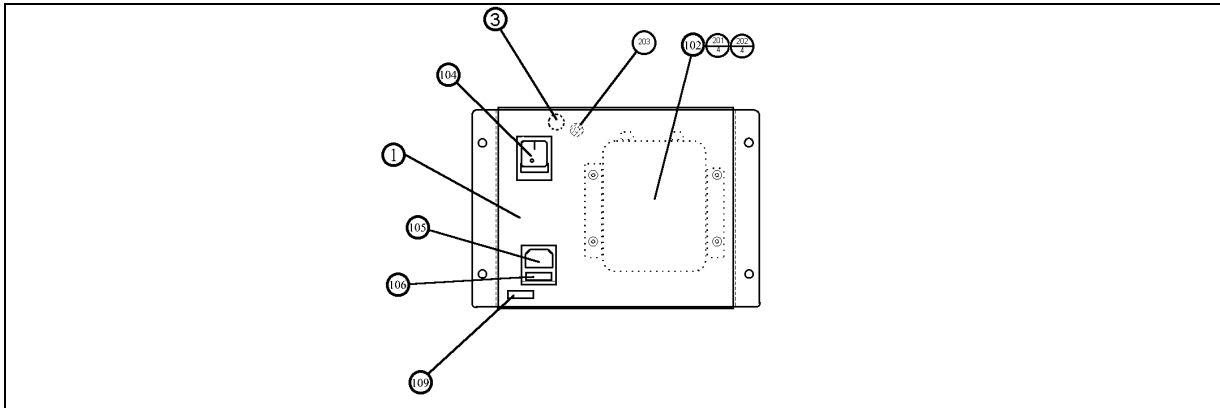

| INDENT | PART NO. | QTY | DESCRIPTION | COMPONENT REF |
|--------|-----------------|------|------------------------------|----------------|
| 1 | HOD-1021UK | 1 | AC BRKT UK | |
| 3 | LB1096 | 1 | STICKER PROTECTIVE EARTH | (EARTH STUD) |
| 102 | EP1379 | 1 | FILTER EMI 10A ARCOTRONICS | |
| 104 | SW1109 | 1 | SWITCH ROCKER 250V AC | |
| 105 | EP1302 | 1 | EUROSOCKET FUSED 10A 250Vac | |
| 106 | 514-5078-5000 | 1 | FUSE 5X20 CERAMIC SB 5000mA | |
| 107 | 310-5029-D508 | 0.04 | HEAT SHRINK SLEEVING 50.8DIA | |
| 109 | 421-6595-5000-T | 1 | STICKER FUSE 5000mA TYPE T | |
| 201 | 000-P00308 | 4 | M3X8 MSCR POSI PAN PAS | (102)-4 |
| 202 | 060-F00300 | 4 | M3 WSHR FORM A FLT PAS | (102)-4 |
| 203 | 050-F00400 | 2 | M4 NUT FLG | EARTH STUD |
| 301 | 600-6911-049UK | 1 | WIRE HARN AC BRKT (JPT) | |
| 302 | 600-7118-002UK | 1 | WIRE HARN AC OUT (PRIMARY) | |
| 303 | 600-9040-45U | 1 | WIRE HARN EARTH 400mm M4/M5 | AC BRKT - XFMR |

8.20. HOD-1070UK ASSY SPEAKER

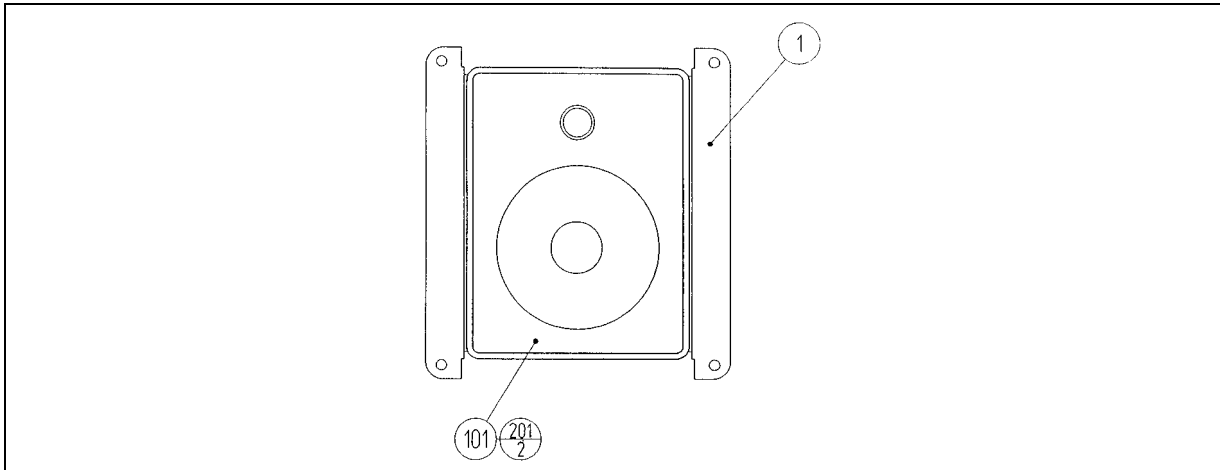

| ITEM | PART NO. | QTY | DESCRIPTION | COMPONENT REF |
|------|--------------|-----|------------------------------|---------------|
| 1 | CPT-1061UK | 1 | SPEAKER BRKT UK | |
| 101 | 130-5096 | 1 | ASSY SERVO SPEAKER BOX | |
| 201 | 000-P00512-W | 2 | M5X12 MSCR POSI PAN W/FS PAS | (101)-2 |
| 301 | HOD-60025 | 1 | WIRE HARN SPEAKER UNIT | |

8.21. HDT-1530UK ASSY FAN UNIT DC UK

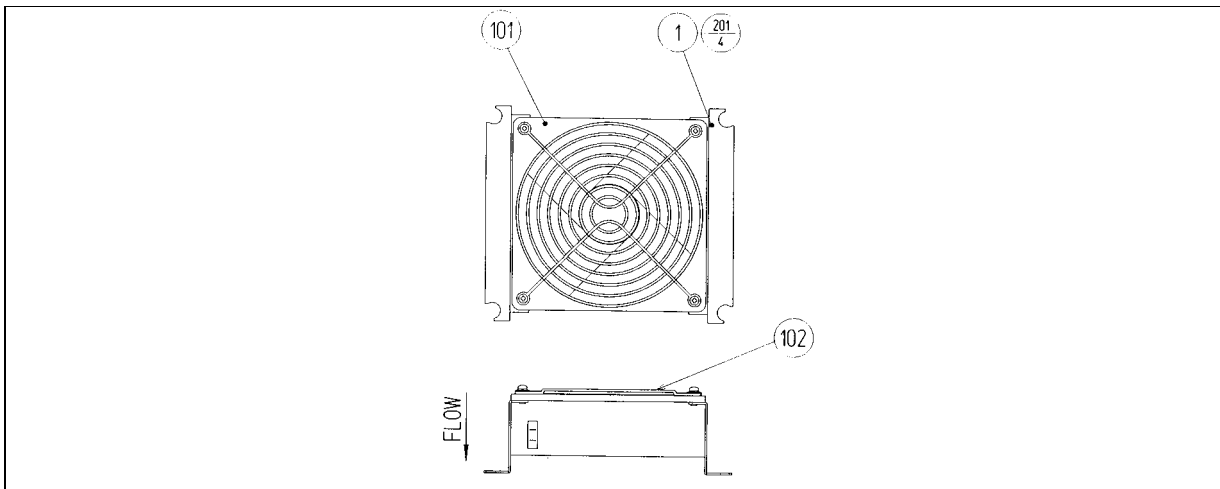

| Item | Component Part | Qty. | Description | Component Reference |
|------|----------------|------|----------------------------|---------------------|
| 1 | 105-5340-01 | 2 | FAN BRKT LONG | |
| 101 | EC814500 | 1 | 12V DC FAN 120MM KD1 | |
| 102 | FN1012 | 1 | MESH GUARD METAL 120mm FAN | |
| 201 | 000-P00312-W | 4 | M3X12 MSCR PAN W/FS PAS | (1)-4 |
| 301 | HDT-60004UK | 1 | WH 12V FAN LINK | |

9. APPENDIX A - ELECTRICAL SCHEMATIC

9.1. WIRE COLOURS

THE WIRE COLOUR CODE IS AS FOLLOWS:

| | |
|---|-------------|
| A | PINK |
| B | SKY BLUE |
| C | BROWN |
| D | PURPLE |
| E | LIGHT GREEN |

Wires other than those of any of the colours listed above will be displayed by 2 alphanumeric characters:

| | |
|---|--------|
| 1 | RED |
| 2 | BLUE |
| 3 | YELLOW |
| 4 | GREEN |
| 5 | WHITE |
| 7 | ORANGE |
| 8 | BLACK |
| 9 | GREY |

If the right hand side numeral of the code is 0, then the wire will be of a single colour shown by the left hand side numeral (see the list above).

Note 1: If the right hand side alphanumeric is not 0, that particular wire has a spiral colour code. The left hand side character shows the base colour and the right hand side one, the spiral colour.

[Example] 51----- WHITE/RED = WHITE wire with RED stripes

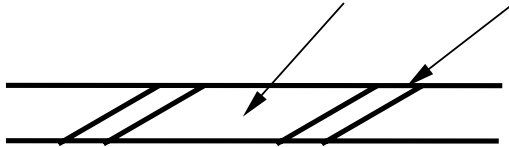

Note 2: The character following the wire colour code indicates the size of the wire.

| | |
|------|---------------|
| K: | AWG18, UL1015 |
| L: | AWG20, UL1007 |
| None | AWG22, UL1007 |

9.2. ELECTRICAL SCHEMATIC

The following pages contain the electrical schematic for this machine.

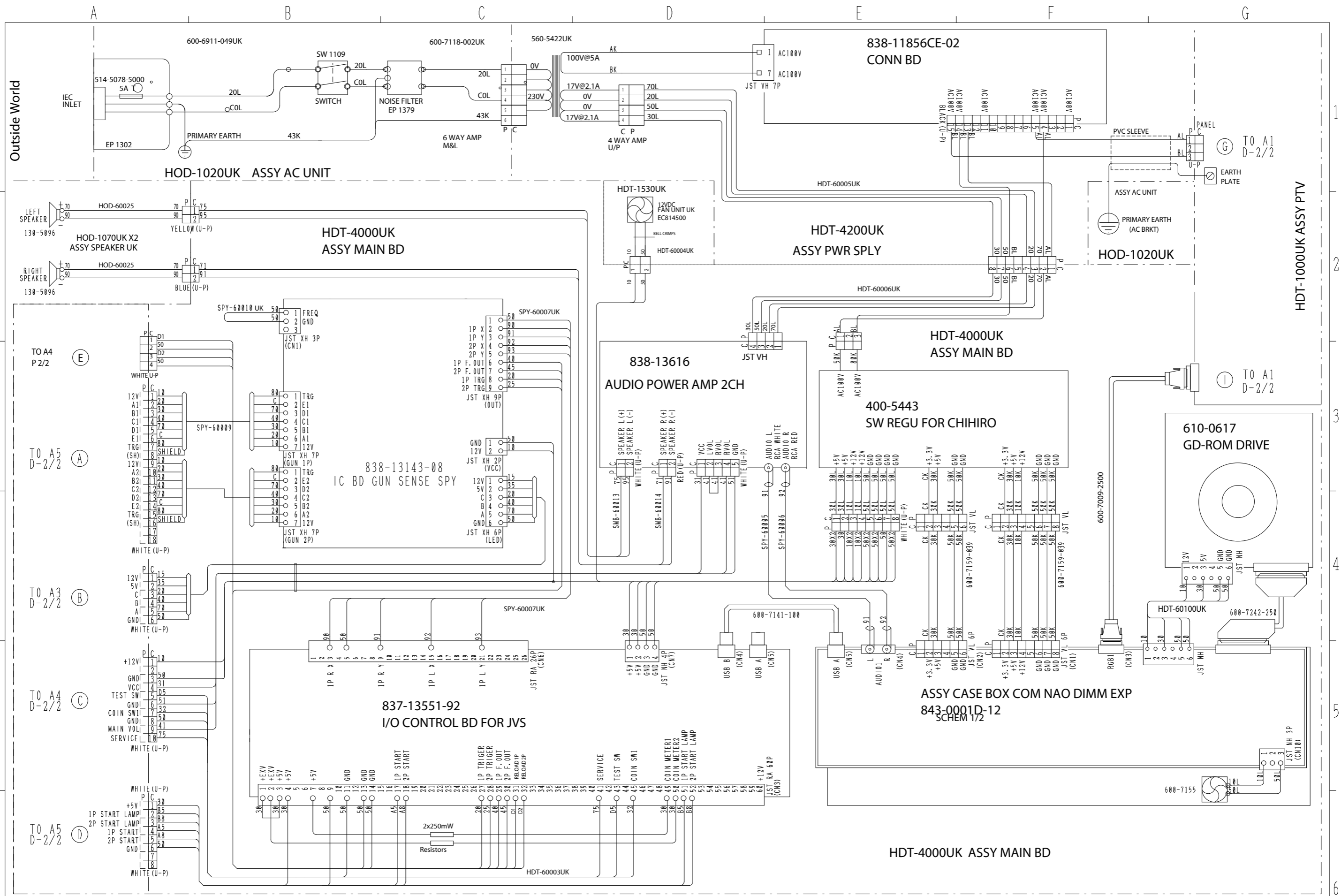

| | | | | | |
|---|--------|---|-------------|----|--------------|
| 8 | BLACK | E | LIGHT GREEN | 43 | EARTH WIRE |
| 7 | ORANGE | D | PURPLE | U | ANG16 UL1815 |
| 5 | WHITE | C | BROWN | K | ANG18 UL1815 |
| 4 | GREEN | B | SKY BLUE | L | ANG28 UL1887 |
| 3 | YELLOW | A | PINK | 9 | GRAY |
| 2 | BLUE | | | | |
| 1 | RED | | | | |

| | | | |
|------------|----------|--|--|
| HDT-0000UK | 21/10/02 | | |
| TOP-ASS'Y | | | |

| | |
|-----------------------------|--|
| SEGA SEGA ENTERPRISES, LTD. | THIS DRAWING WILL IN NO WAY BE COPIED. TO BE TURNED ON DEMAND. |
| HOUSE OF THE DEAD 3 DX | |
| DESCRIPTION | DIAGRAM NO. |

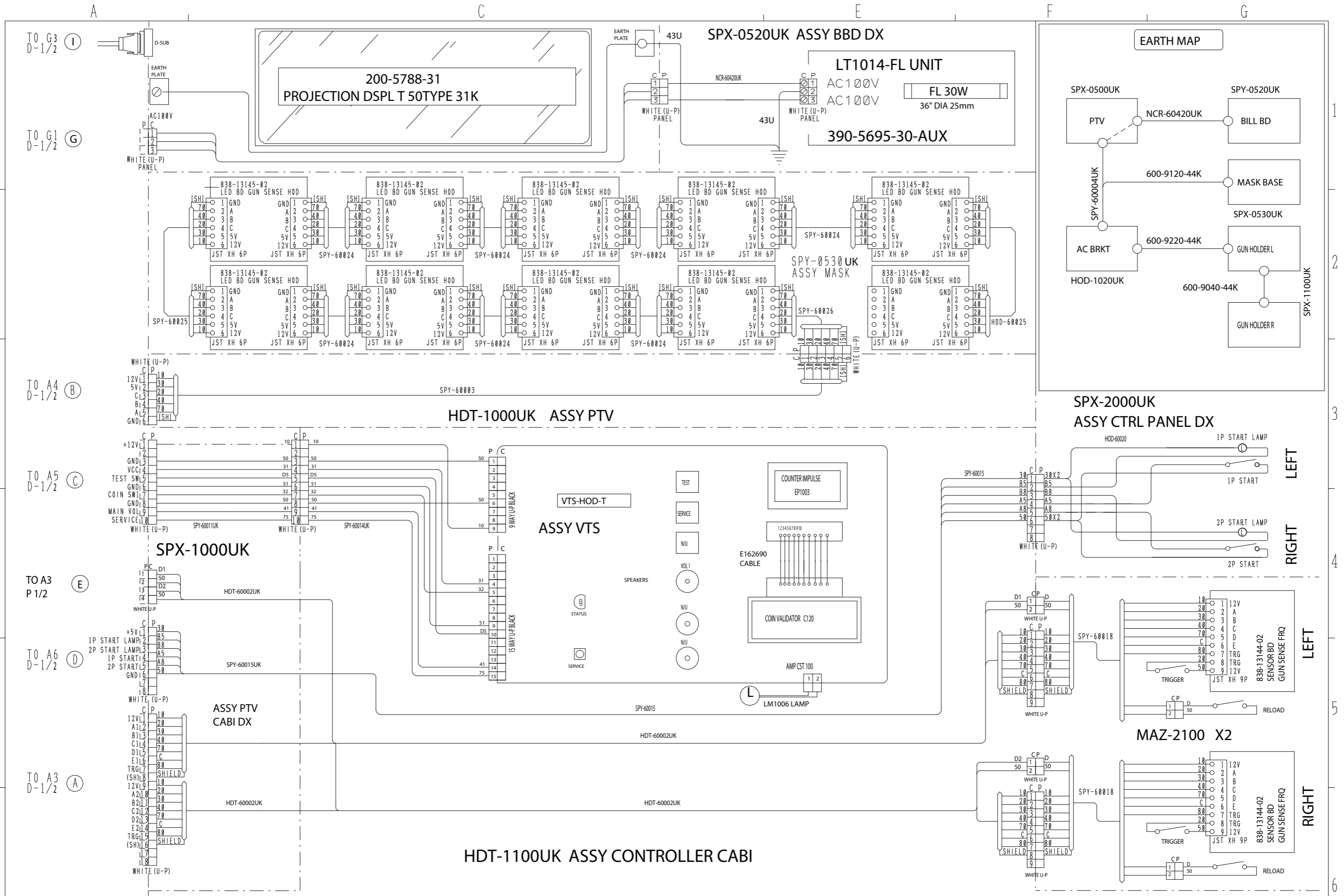

| | | | | | |
|---|--------|---|-------------|----|--------------|
| 8 | BLACK | E | LIGHT GREEN | 43 | EARTH WIRE |
| 7 | ORANGE | D | PURPLE | U | ANG16 UL1815 |
| 5 | WHITE | C | BROWN | K | ANG18 UL1815 |
| 4 | GREEN | B | SKY BLUE | L | ANG28 UL1887 |
| 3 | YELLOW | A | PINK | Q | ANG22 UL1887 |
| 2 | BLUE | 9 | GRAY | | |
| 1 | RED | | | | |

HDT-0000UK
TOP-ASS'Y

DRAWN
CW
21/10/02

SEGA SEGA ENTERPRISES, LTD. THIS DRAWING WILL IN NO WAY BE COPIED.
TO BE TURNED ON DEMAND.
HOUSE OF THE DEAD 3 DX
SCHEM 2/2

DIAGRAM NO.

SEGA AMUSEMENTS EUROPE LTD./ SEGA SERVICE CENTRE

Suite 3a
Oaks House
12 - 22 West Street
Epsom
Surrey
United Kingdom
KT18 7RG

Telephone: +44 (0) 1372 731820

Fax: +44 (0) 1372 731849

SEGA[®]



© SEGA 2002