

SERVICE MANUAL



TWIN TYPE



Before using this product, read this SERVICE MANUAL carefully to understand the contents stated herein. After reading this manual, be sure to keep it available nearby the product or somewhere convenient in order to be able to refer to it whenever necessary.

Manufactured in the UK by



CONTENTS

1.	BEFORE USING THIS PRODUCT.....	5
1.1.	Inspections Immediately After Transporting The Product To The Location	6
2.	INTRODUCTION TO THIS SERVICE MANUAL	8
3.	INSTALLATION AND SERVICE INSTRUCTIONS	9
3.1.	Handling and Installation Precautions.....	9
3.2.	Coin Handling	11
3.3.	Name of Parts.....	12
3.4.	Accessories	13
3.5.	Shipping the Game Board.....	14
3.6.	Shipping the GD-ROM Drive.....	16
3.7.	Assembly Instructions	17
3.7.1.	Applying the Play Instructions	18
3.7.2.	Assembling the Cockpit	19
3.7.3.	Securing In Place (Leg Adjuster Adjustment)	20
3.7.4.	Billboard Installation.....	22
3.7.5.	Installing The AC Covers (Wire Covers).....	23
3.7.6.	Coin Handling Installation	24
3.7.6.1.	Wiring Connections.....	25
3.7.7.	Communication Cables	26
3.7.8.	Connection To The Power Supply.....	27
3.7.9.	Assembly Check.....	29
3.7.9.1.	CRT Test	29
3.7.9.2.	Memory Test.....	30
3.7.9.3.	Input Test.....	31
3.7.9.4.	Output Test	32
3.7.9.5.	Sound Test	32
3.7.10.	Moving The Machine.....	33
3.8.	Fuses	34
3.9.	Maintenance.....	35
3.9.1.	Handle Mecha.....	36
3.9.1.1.	Removing the Handle Mecha.....	36
3.9.1.2.	Replacing and Adjusting The Handle Mecha's V.R.	36
3.9.1.3.	Adjusting the VR	37
3.9.1.4.	Replacing the VR.....	37
3.9.1.5.	Greasing	38
3.9.2.	Accelerator & Brake.....	39
3.9.2.1.	Removing the Accelerator & Brake.....	39
3.9.2.2.	Adjusting the V.R.	40
3.9.2.3.	Replacing the V.R.....	41
3.9.2.4.	Greasing	41
3.10.	Shift Lever	42
3.11.	Replacement of Fluorescent Lamp and Other Lamps	43
3.11.1.	Fluorescent Lamp Replacement	43
3.12.	Cleaning the Cabinet Surfaces	44
3.13.	Seat (Greasing to Seat Rail Portion).....	44
3.14.	Troubleshooting	45
3.14.1.	Troubleshooting (When No Error Message Is Shown).....	45
3.15.	Gameboard.....	48
3.15.1.	Removing the Board	48
3.15.2.	Removing The GD-ROM Drive.....	49
3.15.3.	Removing The Game Board.....	51
3.15.4.	Composition of the Game Board.....	52
3.15.4.1.	Replacing The Main Board Battery	53
3.15.4.2.	Replacing The Media Board Battery Pack.....	54
3.15.5.	Shipping The Game Board	57
3.15.6.	Shipping The Media Board	59
3.15.7.	Shipping The GD-ROM Drive	60
3.15.8.	Machine Set Up.....	61
3.15.8.1.	Network Play	62

3.16.	Periodic Check and Inspection.....	67
4.	HOW TO PLAY.....	68
4.1.	Basic Controls.....	68
4.2.	Game Outline.....	68
4.3.	Game Flow.....	69
4.3.1.	Versus Mode Entry.....	69
4.3.2.	Car Selection.....	69
4.3.3.	Transmission Selection.....	71
4.3.4.	Mode Selection.....	71
4.3.4.1.	OutRun Mode.....	71
4.3.4.2.	Heart Attack Mode.....	72
4.3.4.3.	Time Attack Mode.....	74
4.4.	Versus Play.....	76
4.4.1.	Versus Mode Game Play.....	76
4.4.2.	Special Versus Mode Commands.....	76
4.4.2.1.	No Handicap Mode.....	76
4.4.2.2.	Player Only Mode.....	76
4.5.	Gameplay Techniques and Secret Commands.....	77
4.5.1.	How to Drift.....	77
4.5.2.	Mid-game Quit Command.....	77
4.6.	Character Introductions.....	78
5.	MAINTENANCE INSTRUCTIONS.....	79
5.1.	Explanation of Test and Data Display.....	79
5.1.1.	VTS Assembly.....	80
5.2.	System Test Mode.....	81
5.2.1.	RAM Test.....	82
5.2.2.	JVS Test.....	82
5.2.3.	Sound Test.....	83
5.2.4.	C.R.T Test.....	83
5.2.5.	System Assignments.....	84
5.2.5.1.	Coin Assignments.....	84
5.2.5.2.	Coin/Credit Setting (Coin Chute Common Type).....	85
5.2.5.3.	Coin/Credit Setting (Coin Chute Individual Type).....	86
5.2.5.4.	Manual Setting.....	87
5.2.5.5.	Sequence Setting.....	88
5.2.5.6.	Bookkeeping.....	89
5.2.5.7.	Backup Data Clear.....	89
5.2.5.8.	ROM BD Test.....	90
5.2.5.9.	Clock Setting.....	90
5.3.	Game Test Mode.....	91
5.3.1.	Input Test.....	92
5.3.2.	Output Test.....	93
5.3.3.	Drive Board Test.....	94
5.3.4.	Game Assignments.....	95
5.3.5.	Bookkeeping.....	97
5.3.6.	Backup Data Clear.....	99
6.	COIN MECH INSTALLATION AND CREDIT BOARD SET UP.....	100
6.1.	Introduction.....	100
6.1.1.	Price of Play Settings UK.....	103
6.1.2.	Price Of Play Settings Euro.....	104
6.1.3.	Price Of Play Settings Austria-Czech-Denmark-Norway-Israel-France2.....	105
7.	DESIGN RELATED PARTS.....	106
8.	PARTS LIST.....	107
8.1.	Assembly Structure.....	107
8.2.	ORT-00001UK TOP ASSY OUTRUN2 TWIN.....	108
8.3.	ORT-10001UK ASSY COCKPIT 1P.....	110
8.4.	DUT-1120UK ASSY SUB MAIN BASE.....	113
8.5.	ORT-1550UK ASSY MONITOR COVER L 2P.....	114
8.6.	APC-1560 ASSY SPEAKER L.....	115
8.7.	ORT-1555UK ASSY MONITOR COVER R 2P.....	116

8.8.	APC-1565 ASSY SPEAKER R.....	117
8.9.	ORT-2000UK ASSY CONTROL PANEL.....	118
8.10.	SPG-2500 ASSY HANDLE MECHA	120
8.11.	ORT-2100UK-ASSY SW PLATE	122
8.12.	ORT-1100UK ASSY PEDAL BASE ORT.....	123
8.13.	SPG-2200 ASSY BRAKE & ACCELL.....	124
8.14.	ORT-1600UK ASSY SEAT TWIN 1P	126
8.15.	ORT-4500UK ASSY MAIN BD	128
8.16.	ORT-4600UK ASSY ELEC BD.....	129
8.17.	FRI-1510UK ASSY BASE LID R	131
8.18.	ORT-INST-TW ASSY INSTALLATION KIT ORT TWIN	132
8.19.	ORT-0200UK ASSY BILLBOARD	133
8.20.	FRI-0300UK ASSY COINCHUTE TOWER FRI.....	134
8.21.	ORT-0500UK ASSY WIRE COVER ORT TWIN	135
8.22.	ORT-0400UK ASSY AC BRKT MAIN.....	136
8.23.	ORT-0700UK ASSY AC BRKT SUB	137
8.24.	ORT-4560UK ASSY LAN COM2	138
9.	APPENDIX A - ELECTRICAL SCHEMATIC	139
9.1.	Wire Colours.....	139
9.2.	Electrical Schematic	139

1. BEFORE USING THIS PRODUCT

To ensure the safe usage, be sure to read the following before using the product. The following instructions are intended for the use of QUALIFIED SERVICE PERSONNEL ONLY.

If any activity is carried out on the product, this should be done only after carefully reading and sufficiently understanding the instructions.

Only qualified service personnel should carry out maintenance on the product.

Depending on the potential risk, terms such as "WARNING!" "CAUTION" and "IMPORTANT!" are used where an explanation is given that requires special attention. SEGA is not responsible for injury or damage caused by use in a manner contrary to the instructions given in this document.

In order to prevent accidents warning stickers and printed instructions are applied in the places where a potentially hazardous situation relating to the product could arise. Be sure to comply with these warnings.



Indicates that mishandling the product by disregarding this warning will cause a potentially hazardous situation that can result in death or serious injury.



Indicates that mishandling the product by disregarding this caution will cause a potentially hazardous situation that can result in personal injury and or material damage.



This is cautionary information that should be complied with when handling the product. Indicates that mishandling the product by disregarding this will cause a potentially hazardous situation that may not result in personal injury but could damage the product.

Be sure to turn off the power and disconnect from the mains supply before working on the machine.

Ensure that the correct fuses are fitted to the machine. Details of these are enclosed in the Service Manual.

Ensure that only qualified Service Engineers perform any maintenance work on the machine.

Specification changes, removal of equipment, conversion and/or additions not designated by SEGA are not permitted and will invalidate this product's CE conformity.

Warning labels or safety covers for personal protection etc, are component parts of the product. A potential hazard will be created if the machine is operated while any parts have been removed. Do not operate the product if any doors, lids or protective covers become damaged or lost. SEGA is not liable in any whatsoever for any injury and/or damage caused by specification changes not designated by SEGA.

Before installing the product, check for the Electrical Specification Sticker, SEGA products have a sticker on which the electrical specifications are detailed. Ensure that the product is compatible with the power supply voltage and frequency requirements of the location in which the machine is to be installed.

Install and operate the machine only in places where appropriate lighting is available, allowing warning stickers to be clearly read.

To ensure maximum safety for customers and operators, stickers and printed instructions describing potentially hazardous situations are applied to potentially hazardous locations. Ensure that the product's operating location has sufficient lighting to allow any warnings to be read. If any sticker or printed warning is removed or defaced, do not operate the machine until an identical item has replaced it.

Exercise great care when handling the monitor (applies only to product with monitor). Some of the monitor (TV) parts are subject to high-tension voltage. Even after turning the power off some components are liable to high-tension voltage. Only qualified service engineers should perform monitor repair and replacement.

In cases where commercially available monitors and printers are used, only the items relating to this product are contained in this manual. Some commercially available equipment will have functions and reactions not referred to in this manual. This manual should be read in conjunction with the specific manufacturer's manual for such equipment.

Descriptions contained herein may be subject to change without prior notification.

The contents described herein are fully prepared with due care. However, should any question arise or errors be found please contact **SEGA AMUSEMENTS EUROPE LTD.**

Descriptions contained herein may be subject to change without prior notification.

The contents described herein are fully prepared with due care. However, should any question arise or errors be found please contact SEGA.

1.1. *Inspections Immediately After Transporting The Product To The Location*



- Only QUALIFIED SERVICE PERSONNEL should carry out inspection.

Normally, at the time of shipment, SEGA products are in a state to allowing usage immediately after transporting to the location. Nevertheless, an irregular situation may arise during transportation preventing this. Before turning on the power, check the following points to ensure that the product has been transported safely.

- Are there any dented parts or defects (cuts, etc.) on the external surfaces of the product?
- Are castors and leg adjusters present and undamaged?
- Do the power supply voltage and frequency requirements meet with the local supply?
- Are all wiring connectors correctly and securely connected? Unless connected in the correct direction, connector connections cannot be made successfully. Do not insert connectors forcibly.
- Are all IC's of each IC BD firmly inserted?
- Does the power cord have any cuts or dents?
- Do fuses meet the specified rating?
- Are such units such as monitors, control equipment, IC BD, etc. firmly secured?
- Are all earth wires connected?
- Are all accessories available?
- Can all doors and lids be opened with the accessory keys and/or tools?

CONCERNING THE STICKER DISPLAY

SEGA product has stickers describing the product manufacture number (Serial Number) and electrical specification. If you require service assistance you will require the Serial Number. Identical machines may have different parts fitted internally. Only by quoting the Serial Number will the correct parts be identified.

CONCERNING WARNING STICKERS

SEGA product has warning displays on stickers, labels or printed instructions adhered/attached to or incorporated in the places where hazardous situations can arise. The warning displays are intended for the accident prevention of customers and service personnel.

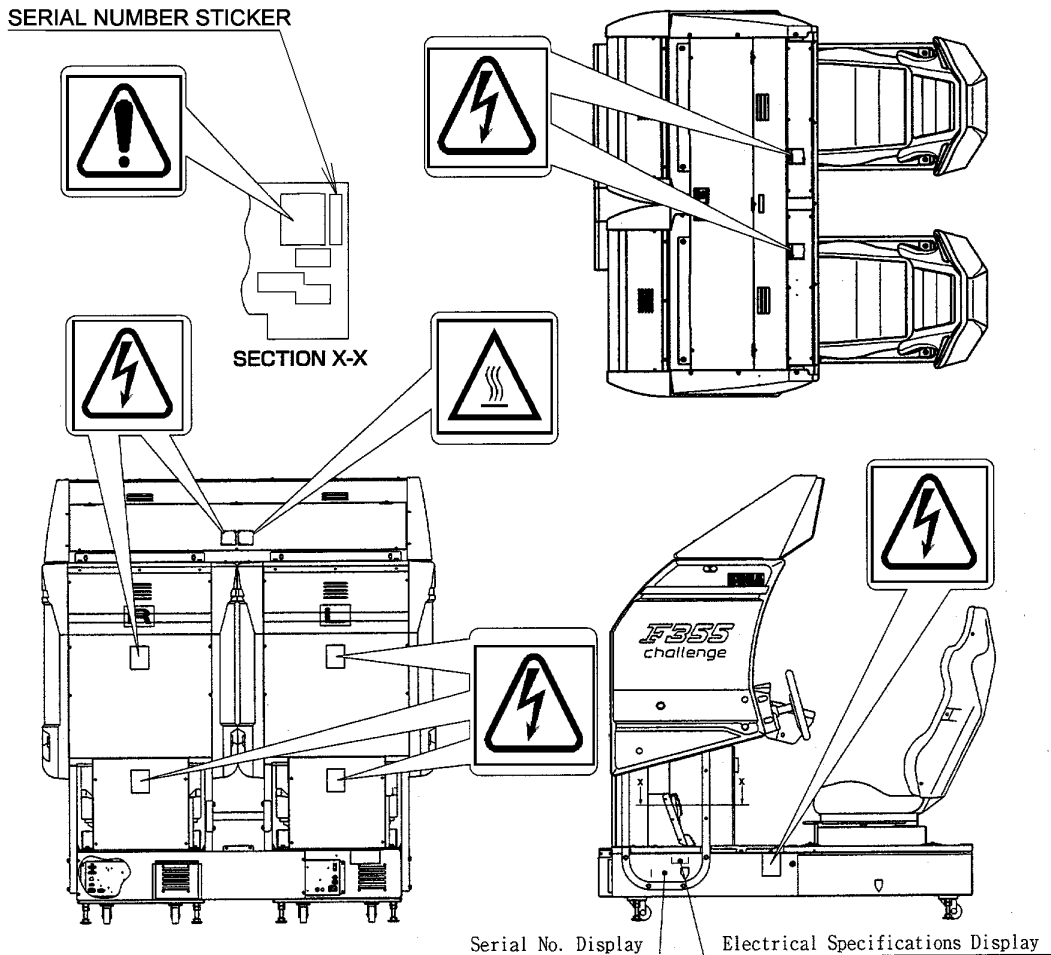

SPECIFICATIONS

Installation Space (cm): 164 x 170
Height (cm): 187
Weight (kg): 510

Power consumption (max): Rated Voltage (V.AC): 220-240 VAC
Rated Current (A): 3 Amps.

Note: Descriptions in this manual are subject to change without prior notice.

2. INTRODUCTION TO THIS SERVICE MANUAL

SEGA ENTERPRISES LTD. supported by its experience in electronic high technology of VLSI's, microprocessors etc. and with a wealth of experience, has for more than 30 years been supplying various innovative and popular games to the world market. This Service Manual is intended to provide detailed descriptions together with all the necessary information covering the general operation of electronic assemblies, electro-mechanicals, servicing controls, spare parts, etc. as regards this new SEGA product. This manual is intended for those who have knowledge of electricity and technical expertise especially in IC's, CRT's, microprocessors etc. Carefully read this manual to acquire sufficient knowledge before working on the machine. Should there be any malfunction, non-technical personnel should under no circumstances touch the internal systems. Should such a situation arise contact our head office.

SEGA AMUSEMENTS EUROPE LTD./ SEGA SERVICE CENTRE

Suite 3a
Oaks House
12 - 22 West Street
Epsom
Surrey
United Kingdom
KT18 7RG

3. INSTALLATION AND SERVICE INSTRUCTIONS



- Only QUALIFIED SERVICE PERSONNEL should carry out installation and commissioning.

3.1. Handling and Installation Precautions

When installing or inspecting the machine, be very careful of the following points and pay attention to ensure that the player can enjoy the game safely.

The game must NOT be installed under the following conditions:

- Outside, the game is designed for indoor use only.
- In areas directly exposed to sunlight, high humidity, dust, excessive heat, or extreme cold.
- In locations that would present an obstacle in the case of an emergency i.e. near fire equipment or emergency exits.
- On unstable surfaces or surfaces subject to vibration.
- Where liquids, other than routine cleaning, may come into contact with the game.

Important:

- Only Qualified Service Personnel should install this machine.
- Be sure to switch the supply power OFF and remove the mains supply plug from the machine before any work is carried out on the machine.
- Do not attempt to repair the PCB's (Printed Circuit Boards) yourself. This will void the warranty. The PCB's contain static sensitive devices that could be damaged.
- Always return a faulty part to your distributor with adequate packaging and protection.
- When removing the plug from the mains always grasp the plug not the cable.
- Do not use a fuse that does not meet the specified rating.
- Make sure all connections are secure before applying power.

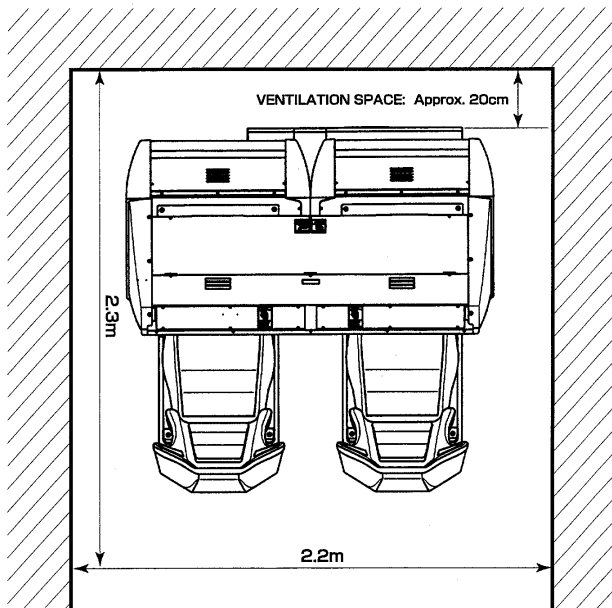

In order to avoid accidents, check the following before starting the operation:

- Check if all of the adjusters are in contact with the surface. If they are not, the Cabinet can move and cause an accident.

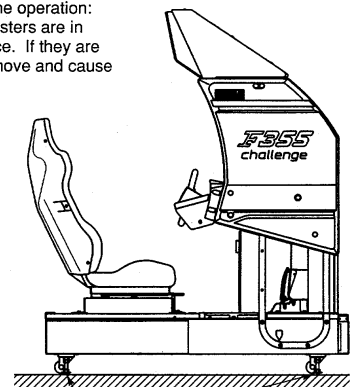

Ensure that all of the Adjusters are in contact with the floor.

Installation Space

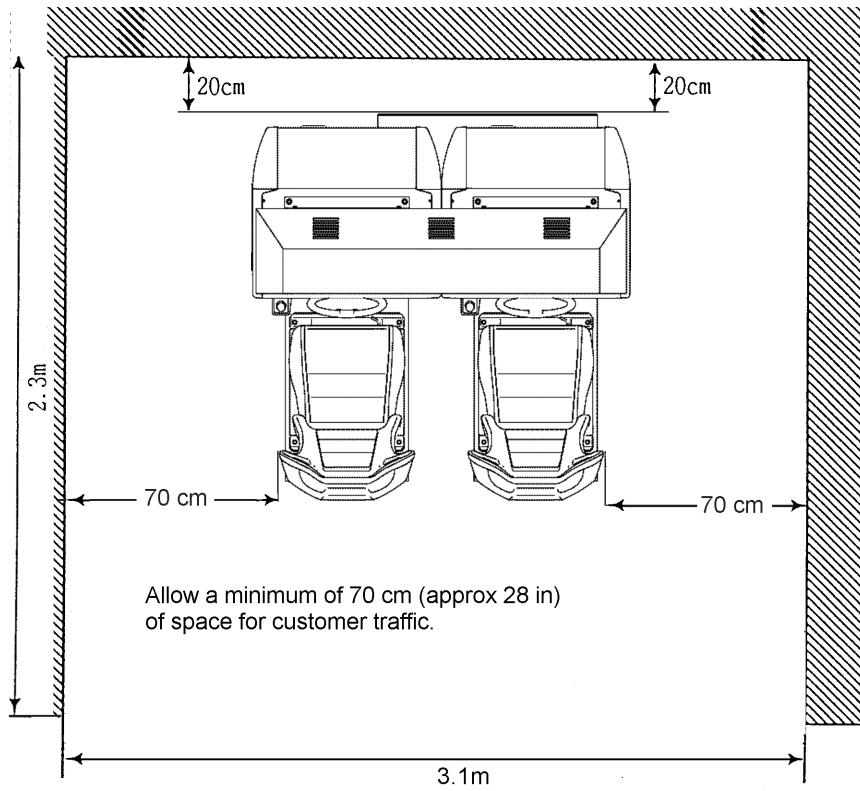



- Ensure that the mains lead is not damaged. If the mains lead is damaged in any way there could be a danger of electric shock or a fire hazard.
- Ensure that the power supply is fitted with circuit protection. Using the power supply without circuit protection is a fire hazard.

3.2. Coin Handling

Standard Sega machines are fitted with a SR3 coin mechanism, however, as a service to our customers Sega machines can be supplied with no coin mechanism or door allowing the customer to fit a coin handling option from the approved list. Fit only the coin handling arrangements detailed below and follow the instructions provided in Section 3.7.6. Failure to fit the coin handling options detailed or failure to follow the installation instructions will render the machine, under the CE marking directive, void.

Approved coin handling options:

- Coin controls SR3
- Generic mechanical
- Mars (MS111B1 and ME115)
- SECI RM4-G20

3.3. Name of Parts

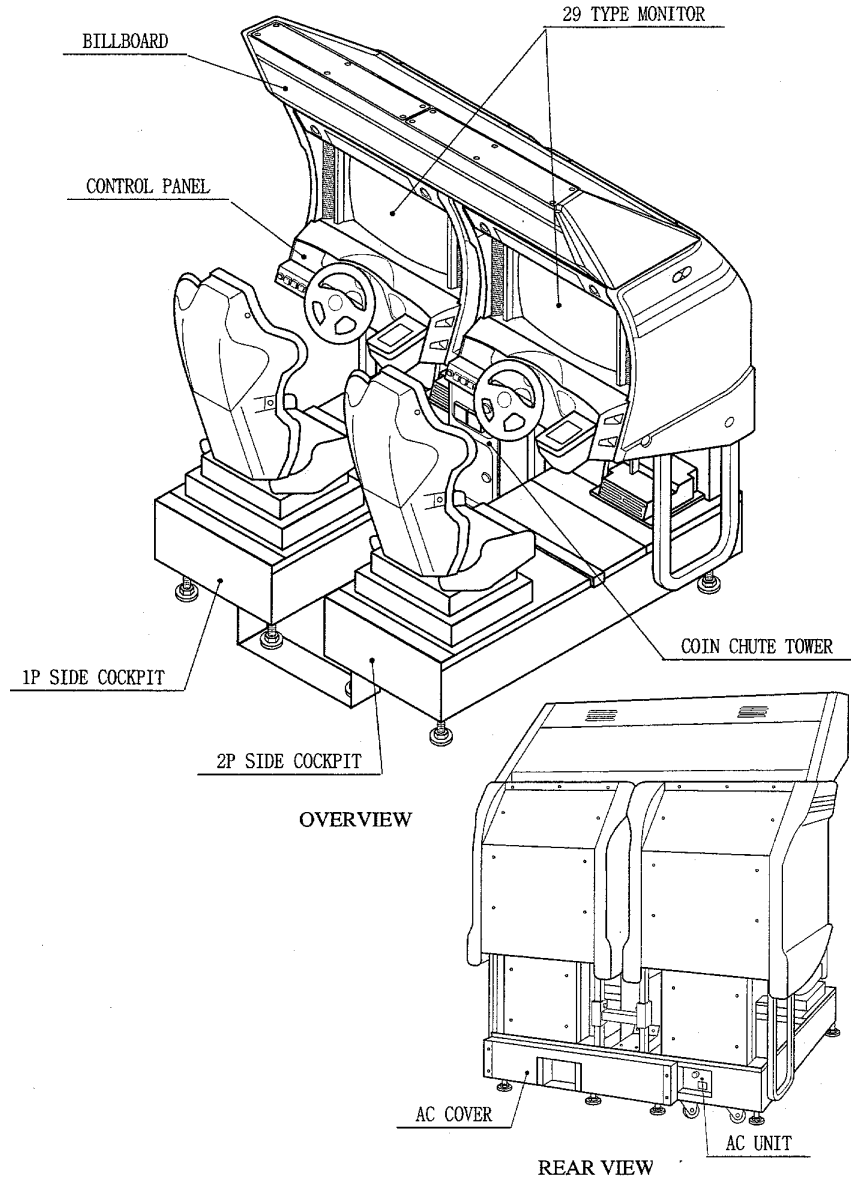

	Width (cm)	Length (cm)	Height (cm)	Weight (kg)
COCKPIT	82	164.5	152	228
COIN CHUTE TOWER	30.5	51.5	570	15
BILLBOARD	160.9	61.7	35.4	36
When Assembled	163.2	170	186.4	507 approx

3.4. Accessories

The machine is supplied with an installation kit. Please ensure the following parts are supplied:

ITEM	PART NO.	QTY	DESCRIPTION
1	ORT-0200UK	1	ASSY BILLBOARD
2	FRI-0300UK	1	ASSY COINCHUTE TOWER FRI
3	ORT-0500UK	1	ASSY WIRE COVER ORT TWIN
4	DYN-0013	1	JOINT PIPE
5	DYN-0006XUK	1	AC COVER B
6	SRT-0018UK	1	AC COVER C
7	DYN-0019UK	1	AC COVER D
8	RAL-XXX-14UK	1	TIE BRACKET RALLY
9	SPG-0008	2	BILLBOARD HOLDER
10	422-0922UK	1	PLAY INSTR SH ORT TWIN MULTI
11	422-0923UK	1	SUB INSTR SH ORT TWIN MULTI
13	PK0344	1	INST KIT BOX ORT TWIN
18	220-5753	1	VOL CONT B-5K OHM (TOCOS)
19	PK0343	0.5	PALLET INST KIT
101	440-CS0186UK	2	STICKER C EPILEPSY MULTI
201	030-000825-SB	20	M8X25 BLT W/S BLK
202	068-852216-0B	20	M8 WSHR 22OD FLT BLK
203	000-P00412-WB	15	M4X12 MSCR PAN W/FS BLK
204	050-F00400	3	M4 NUT FLG SER PAS
401	420-5827	1	SERVICE MANUAL SANWA 31K
402	420-6796-02UK	1	SERVICE MANUAL ORT TWIN
403	OS1019	2	SELF SEAL BAG 9X12.3/4
404	540-0006-01	1	WRENCH M4 TMP PRF
405	540-0007-01	1	WRENCH M5 TMP PRF
406	540-0009-01	1	WRENCH M8 TMP PRF
407	220-5484	1	VOL CONT B-5K OHM
408	SAECE -xxx	1	DECLARATION OF CONFORMITY
409	514-5078-5000	2	FUSE 5X20 CERAMIC SB 5000mA
411	420-6620UK	1	SERVICE MANUAL GD ROM SYSTEM
416	509-5704	1	SW MICRO TYPE (OMRON K3L13)

Item 404-406 - Tamper-proof TORX wrench.

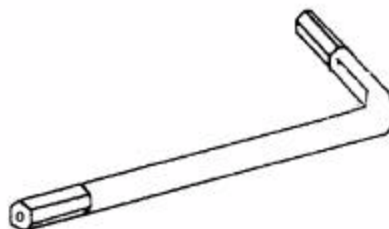

3.5. Shipping the Game Board

 <p>STOP IMPORTANT</p>	<p>Replacement or repair of the Game Board (Chihiro) for this product should be undertaken at the appropriate repair centre. Be sure to follow the specifications below when requesting repairs/sending the board to the repair centre. Not following the specifications may result in the board not being accepted or in extra charges being made.</p> <ul style="list-style-type: none">• Put the game board in the carton box as is. Do not carry out any disassembly or part removal other than that specified.• Follow the procedure and instructions regarding direction below when placing the Game Board in the carton box.• When packing the game board with the Media Board attached, do not remove the Key Chip.• When packing the game board with the Media Board detached, be sure to include the AVIP Cable.• When packing, attach the accessory stickers in the specified places on the Game Board and carton box.
---	---

INSTRUCTIONS

1. Wrap the Chihiro Board in a plastic bag.
2. Place it on top of the bottom surface cushioning material. Turn the Filter Board to face the side with the three honeycomb buffers. Packing it in the opposite direction may cause damage to the Filter Board.
3. Insert corrugated cardboard into the space between the lateral honeycomb buffers of the bottom surface cushioning material and stow the AVIP cable inside.
4. Place the Chihiro Board wrapped in the bottom surface cushioning material into the carton box. Use the handles on the bottom surface cushioning material.
5. Place the upper surface cushioning material on top of the Chihiro Board. Be sure to align it in the right direction, as it will not fit otherwise.
6. Close the top of the carton box and seal it tightly with adhesive tape.

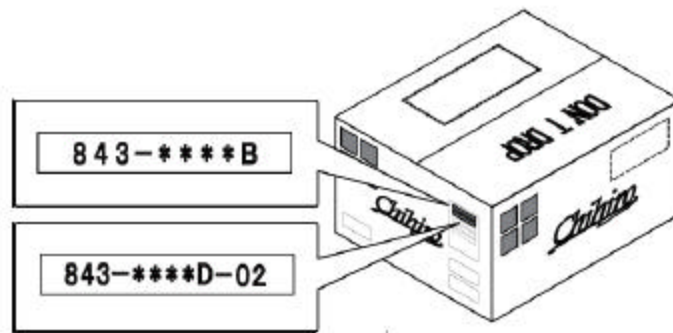
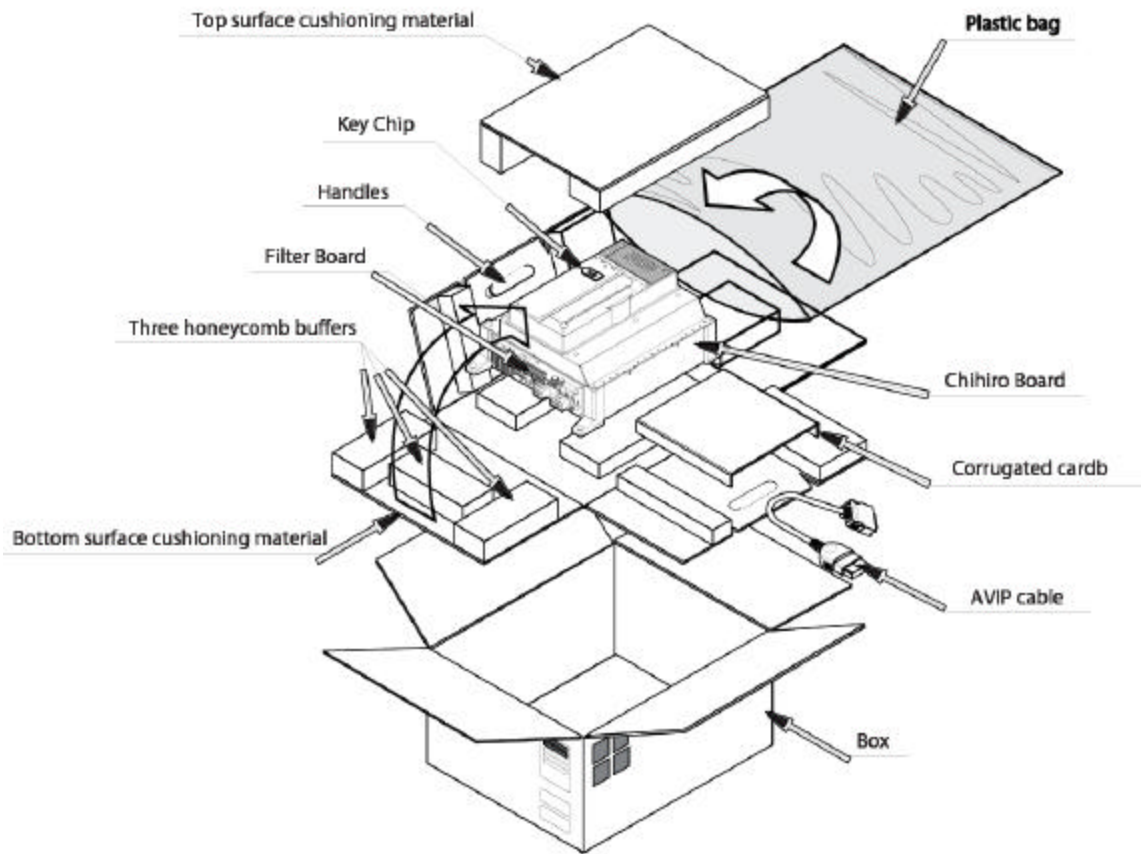

3.6. Shipping the GD-ROM Drive



- When returning the GD-ROM DRIVE for repair or replacement, be sure to package it in the original card transit box - THERE ARE NO USER-SERVICEABLE PARTS INSIDE.
- Ensure the GD-ROM Disk is removed and the GD-ROM Drive Lid is replaced on the unit, with fixing screw, before packaging. Also, remove the GD-ROM Drive Bracket and store with the four screws for reuse.
- Failure to return the GD-ROM DRIVE in this manner may invalidate the warranty.

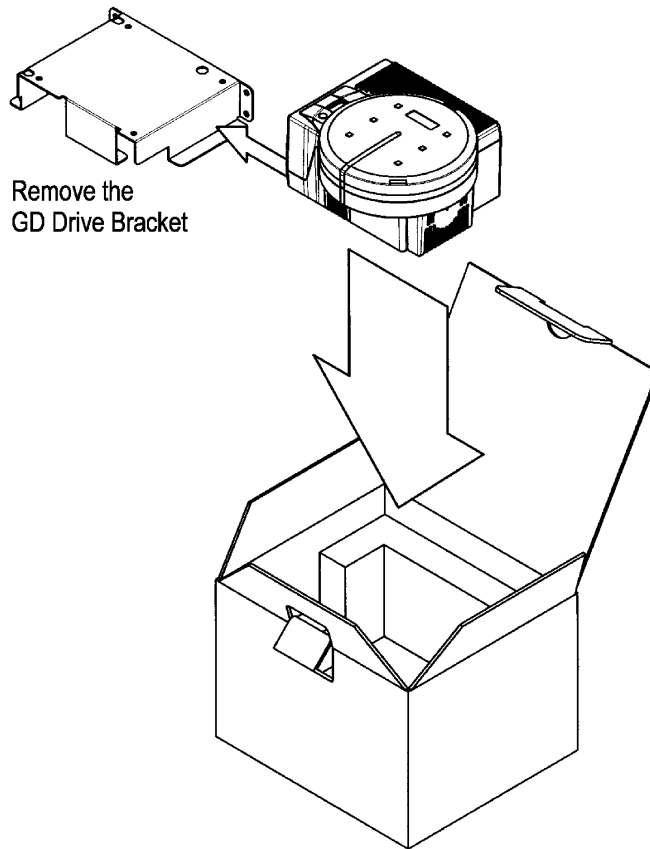

Remove the
GD Drive Bracket

3.7. Assembly Instructions



- Perform the assembly by following the procedure herein stated. Failure to comply with the instructions, for example, inserting the plug into an outlet at a stage not mentioned in this manual can cause an electric shock
- Assembling should be performed as per this manual. Since this is a complex machine, erroneous assembling can cause damage to the machine, or malfunction to occur.
- Do not attempt to complete this work alone, a minimum of 2 people are required.



- Only QUALIFIED SERVICE PERSONNEL should carry out assembly.

When carrying out the assembly work, follow the procedure in the following 7 item sequence

STEP 1 ASSEMBLING THE COCKPIT

STEP 2 SECURING IN PLACE (LEG ADJUSTER ADJUSTMENT)

STEP 3 BILLBOARD INSTALLATION

STEP 4 INSTALLING THE AC COVERS (WIRE COVERS)

STEP 5 COIN HANDLING INSTALLATION

STEP 6 CONNECTION TO POWER SUPPLY

STEP 7 ASSEMBLY CHECK

Note that the parts contained within the installation kit are required for the assembly work.



- Fit all fixings loosely first as detailed in step 1, then position all components before finally tightening fixings at step 6.

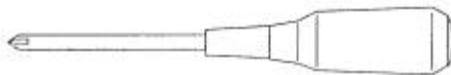

Phillips type screwdriver



WRENCH (for M5 hexagon bolt)

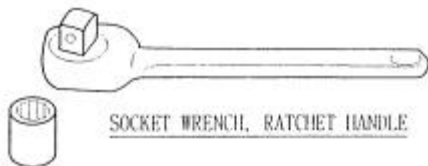

SOCKET WRENCH, RATCHET HANDLE

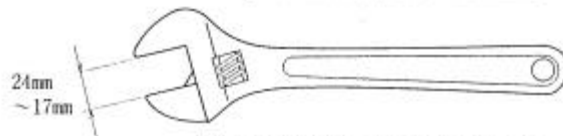

WRENCH (for M16~M10 hexagon bolt)



HEX KEY

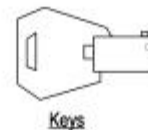

Keys

3.7.1. Applying the Play Instructions



- Only QUALIFIED SERVICE PERSONNEL should carry out this operation.

Supplied in the installation kit are 4 sets of play instructions in 5 languages. Select the language of your choice and apply in the following areas:

1. 422-0922UK: Instructions (on Monitor Mask)
2. 422-0923UK: Instructions (on Control Panel)



3.7.2. Assembling the Cockpit



- Only QUALIFIED SERVICE PERSONNEL should carry out this operation.

1. Place the two cockpits side by side. Position the 1P cabinet, which has the IEC inlet at the left hand side when viewed facing the monitor. STICKER L is attached to the back of the 1P cabinet and STICKER R on the back of the 2P cabinet

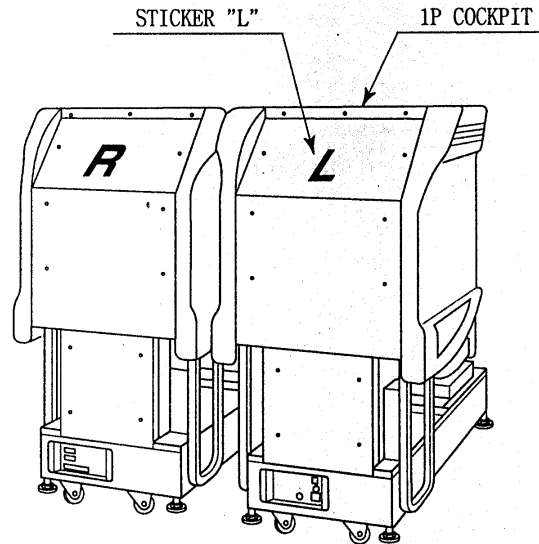

2. Install the coin chute tower in between both cabinets. Open the coin chute door and the cash door and secure with the 4 hexagon bolts from inside the doors. At this time, make sure the bolts are only loosely fitted.

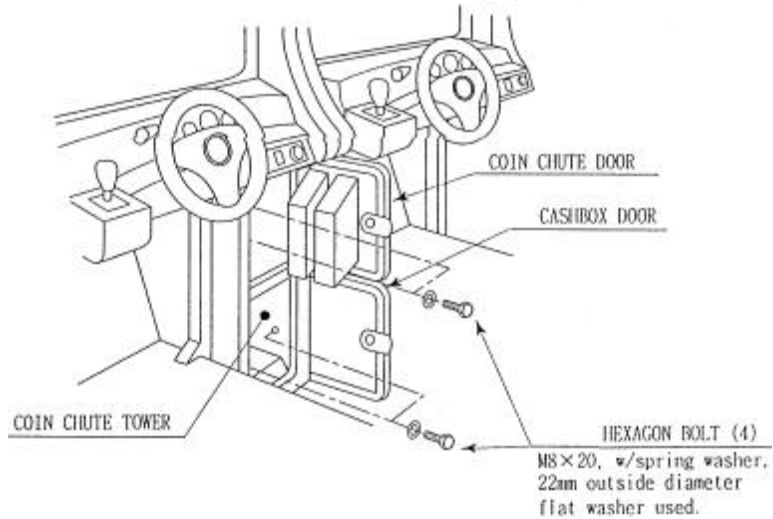

Note: Door may open in opposite way to that shown above

3. Install the joint pipe on the rear-side of both cabinets by securing with 4 hexagon bolts, at this time loosely.

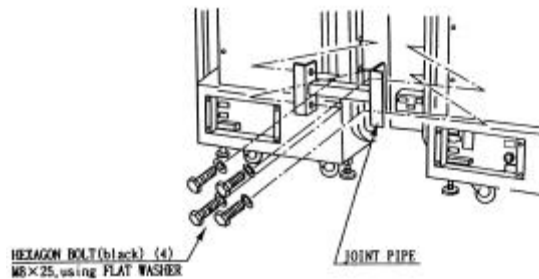

3.7.3. Securing In Place (Leg Adjuster Adjustment)



- Make sure all of the leg adjusters are in contact with the floor. If they are not the machines may move and cause injury. This operation requires 2 people.

- Only QUALIFIED SERVICE PERSONNEL should carry out this operation.

This machine has eight castors and eight leg adjusters. When the installation position is decided, unscrew the leg adjusters so that they raise each caster a minimum of 5mm from the floor. Make sure the machine is level.

1. Move the machine to the installation position. When installing against or close to a wall, be sure to allow an adequate space to allow the player access to the machine.
2. Make the leg adjusters contact the floor. Adjust using a spanner as shown below so that a minimum of 5mm exists between the casters and the floor. Make additional adjustment so that the machine is level.
3. Slide the joint plate onto the shafts of the indicated leg adjusters. Tighten the lock nut on all eight leg adjusters. This will secure the joint plate.

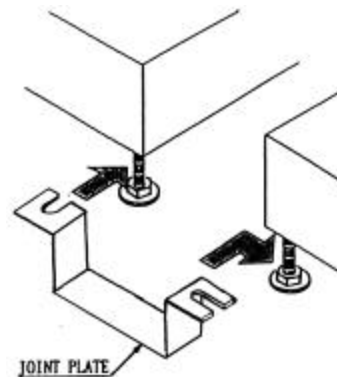
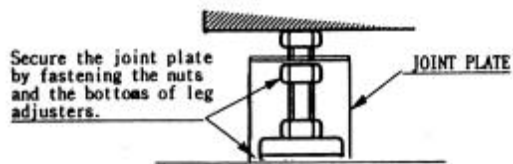
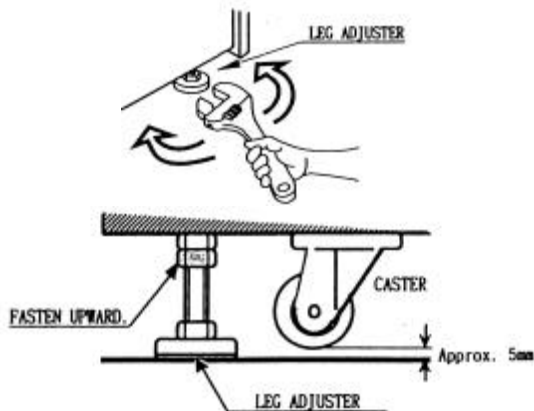
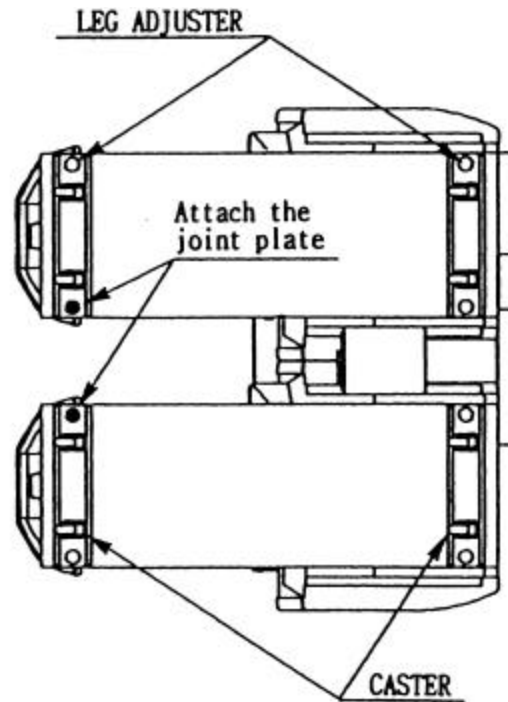

After securing the leg adjuster bolts, fully tighten all bolts temporarily attached in STEP 1 above.

Ensure adequate ventilation is maintained as detailed below

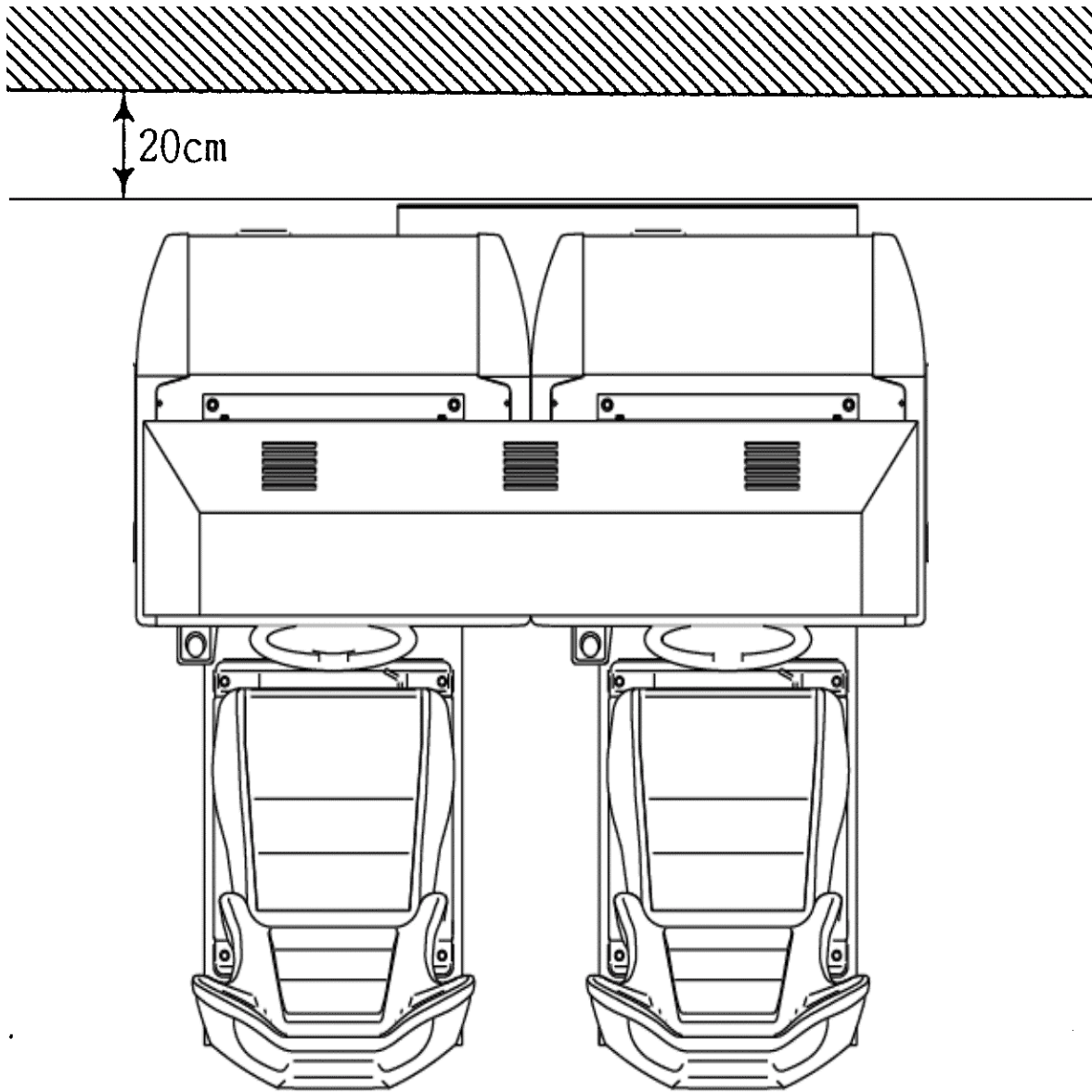

3.7.4. Billboard Installation



IMPORTANT

- One person alone cannot perform the installation of the billboard assembly. Seek assistance before attempting this operation

- Only QUALIFIED SERVICE PERSONNEL should carry out this operation.

1. Install the billboard base over the two cockpits.

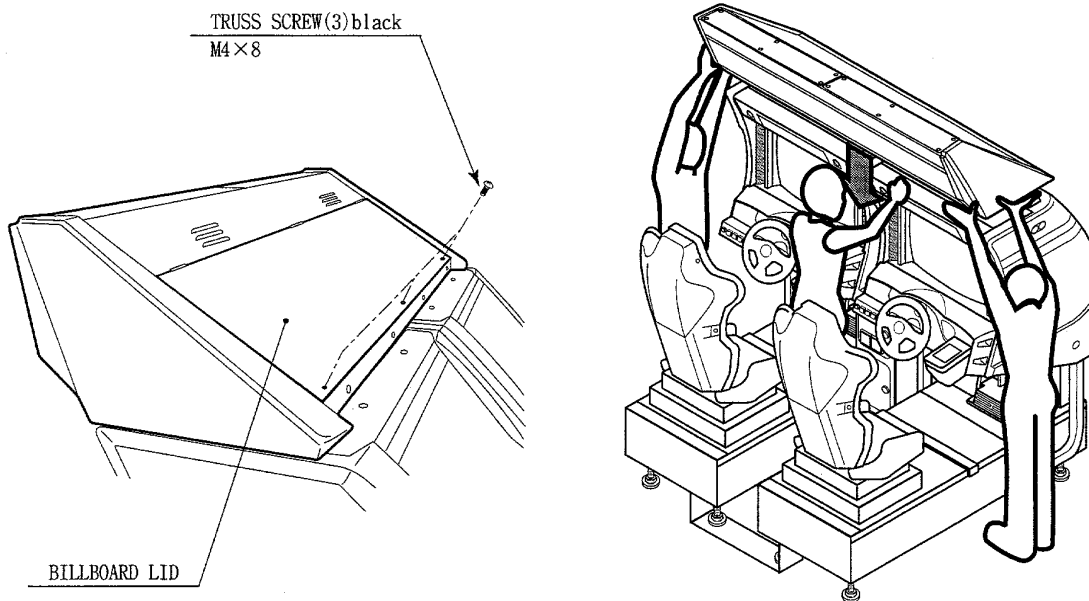

2. Mount the billboard by fitting it onto the billboard base.
3. Install the billboard holders using 2 hexagon bolts each to secure them to the cabinets.
4. Connect the wire connectors from the billboard box to the connectors on the cabinets and install the connector covers using two screws for each.

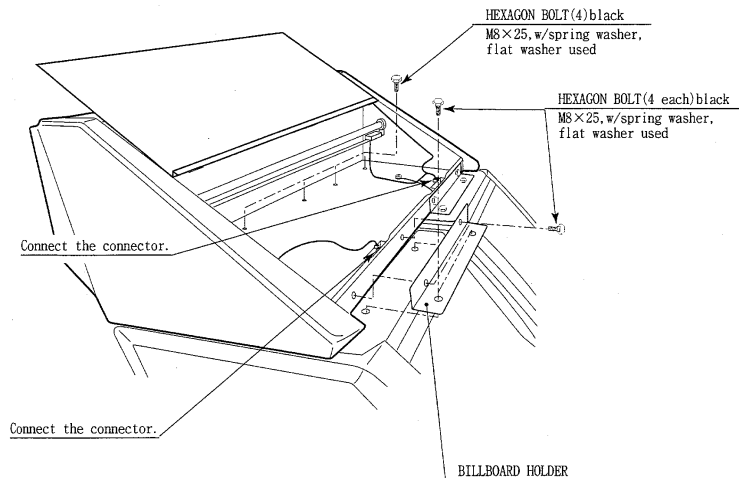

3.7.5. Installing The AC Covers (Wire Covers)



- Be sure that the machine is not connected to the mains supply before attempting this operation.

- Only QUALIFIED SERVICE PERSONNEL should carry out this operation.

The AC Wire Covers are used for protecting the interconnecting wiring and the fibre optic cables. When carrying out this operation be very careful so as not to trap any wire between the covers. Pay attention when handling the fibre optic cables as excessive bending may cause damage.

1. Attach AC Cover A to the rear of the cabinet using 5 screws.
2. Make all the wiring connections between the two cockpits and the Coin Chute Tower. The wiring connectors are colour coded and cannot be fitted into the wrong size connectors. Do not force any connectors together.
3. Connect the earth wires between the two AC Brkts, the AC Covers and the Coin Chute Tower.
4. Insert the fibre optic cables into the fibre optic connectors. Ensure that the “RX” connection on the 1P cockpit is connected to the “TX” connector on the 2P cockpit. The other fibre optic connects the “TX” connector of the 1P cockpit to the “RX” connector of the 2P cockpit.
5. Insert AC Cover B into AC Cover A from above and secure using 2 screws. Be sure not to trap any cables.
6. Secure AC Cover C and AC Cover D using 4 screws each.

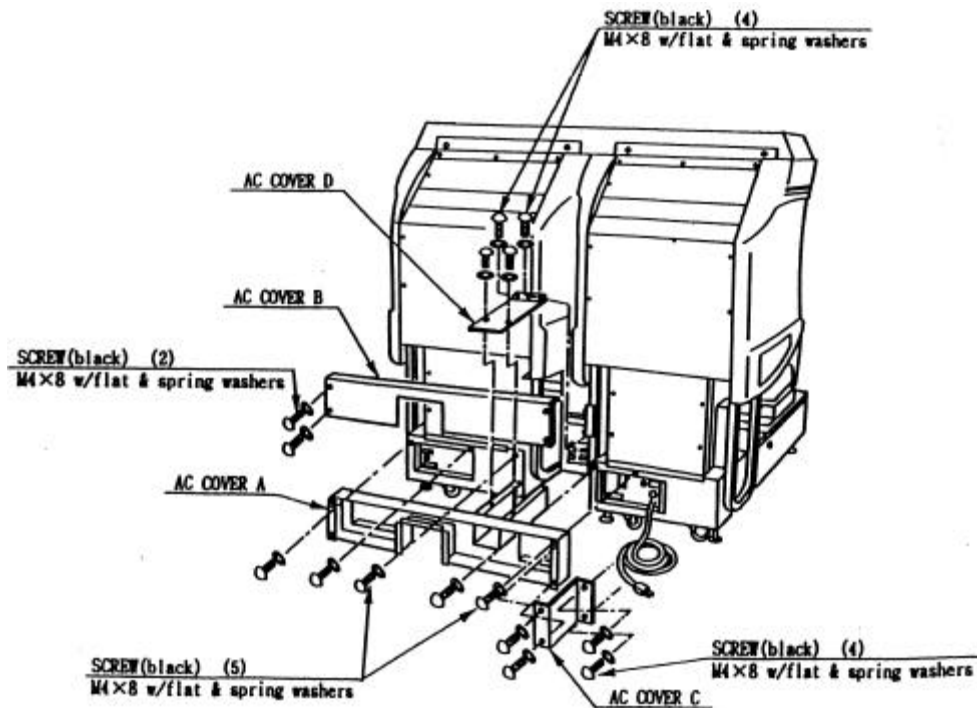

3.7.6. Coin Handling Installation



- Only QUALIFIED SERVICE PERSONNEL should carry out this operation.

When fitting the coin mechanism to the door please refer to the specific manufacturers installation instructions for that coin mechanism. To fit the door to the machine, follow the procedure below.

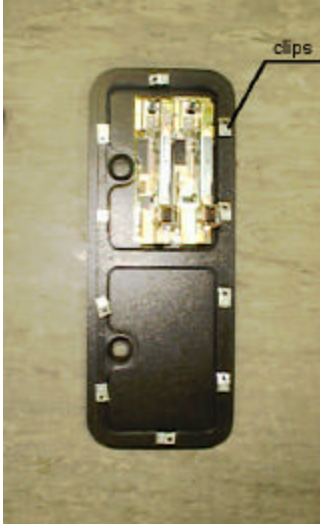

- Loosen all of the bolts on the frame, which secure the clips.
- Turn all clips in towards the door.



- Position the door into the aperture in the machine.
- Turn the clips around so that they will hold the door in the machine.
- Tighten all of the bolts.

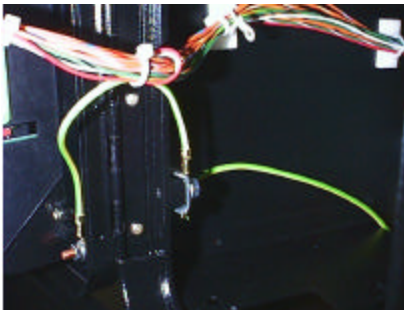

- Ensure that the door is earthed to the frame and the frame is earthed to either the VTS bracket or the coin chute tower.

3.7.6.1.Wiring Connections.

	LOOM	INSTALLATION
COIN MECH C220B	LM1006IDC LM1006LAMP-0.1	<ul style="list-style-type: none"> • Attach the lamp holder to the bracket on the coin return button. • Attach one 15-way connector to the C220 coin mech. • Attach the other 15-way connector to Validator A on the credit board.
GENERIC MECHANICALS	LM1008 LM1008-LAMP	<ul style="list-style-type: none"> • Attach the 2-way connector to 'LAMP' on the VTS board. • Fit the two lamp holders behind the coin return buttons. • Attach the blue cable and orange cable to one mech's microswitch switch. • Attach the blue/green cable and orange/green cable to the other mech's microswitch. • Attach the 2-way mate and lok plug to the 2-way mate and lok cap provided. • Attach one 15-way connector to Validator A and the other to Validator B on the credit board
MARS MS111B1 MARS ME115	LM1007 LM1008-LAMP	<ul style="list-style-type: none"> • Fit the lamp holder to the bracket behind the coin return button. • Fit one of the 13-way connectors to the coin mech. • Fit the other 13-way connector to Validator A on the credit board. Note the 13-way connector is keyed and this key must coincide with the key on the credit board.
SECI, C120, SR3	OWN LOOM AND LM1006LAMP-0.1	<ul style="list-style-type: none"> • Attach the lamp holder to the bracket on the coin return button. • Attach the 2- connector to 'LAMP' on the VTS board. • Attach the validator's own loom to position A on the credit board

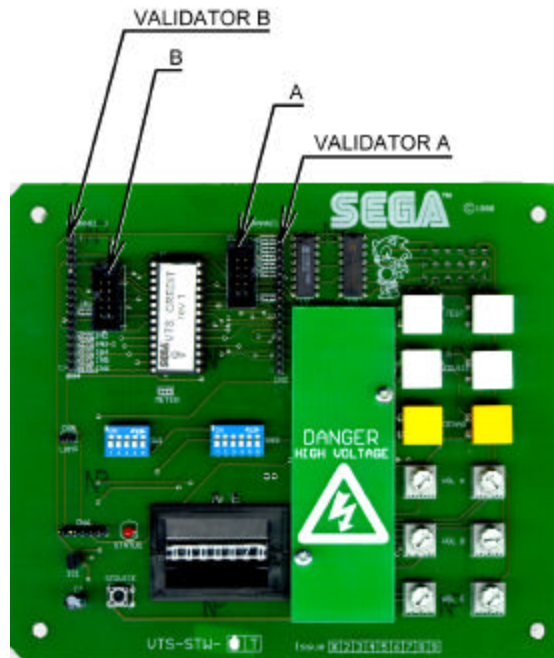

VTS credit board assembly

3.7.7. Communication Cables

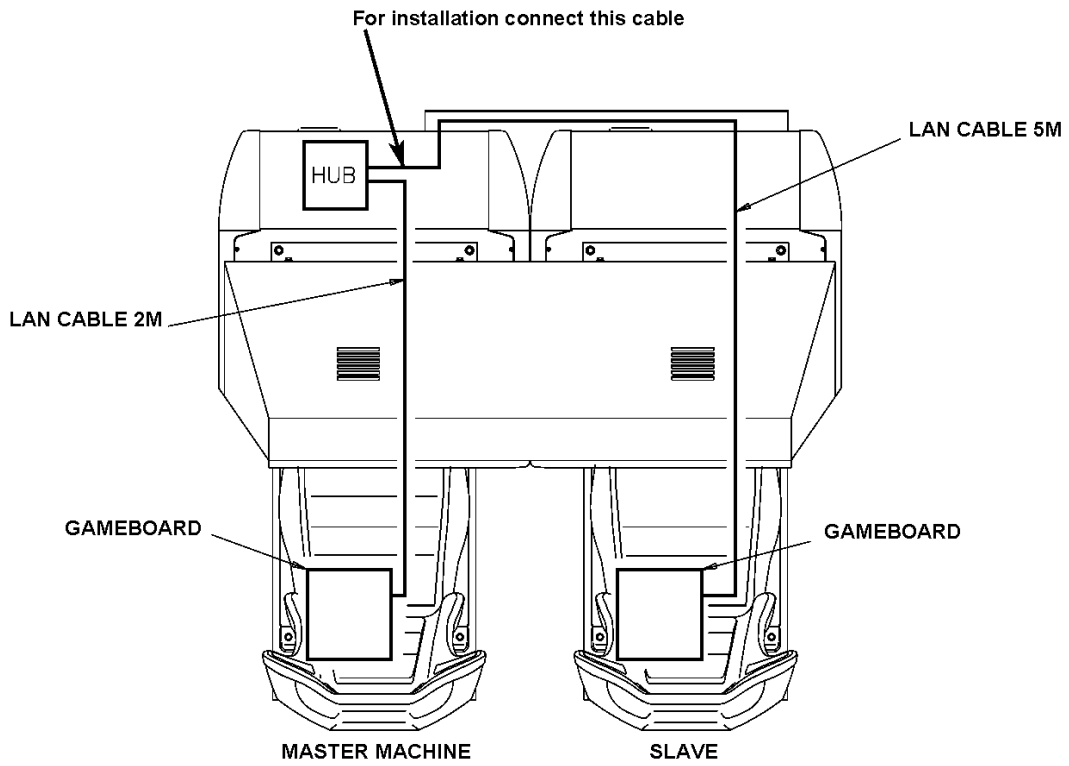

The master (left) machine's LAN cable will come pre-connected to hub.

Connect the slave machine's LAN cable (bundled up at the back in a loop) across via the AC cover to the hub of the master machine and connect to one of the hub's ports.

For machine set-up refer to section 3.15.8.1.

3.7.8. Connection To The Power Supply



- This operation may only be carried out once the machine has been completely assembled.

- Only QUALIFIED SERVICE PERSONNEL should carry out this operation.

The AC Unit is located on the rear of the 1P cockpit. Using the power lead supplied connect this to the mains socket at the wall.

1. Turn the mains switch on.
2. Turn the switch on the AC bracket on
3. The machine will start up and go through an initialisation procedure where the steering wheel turns left and right.
4. **DO NOT TOUCH THE MACHINE DURING INITIALISATION.** If the wheel is touched during this time, it could upset the motor settings and affect the feedback performance during gameplay.
5. The gameboard will now be checked for approximately one minute.
6. The network check then starts. After this the attract mode will appear. If after 30 seconds or so, the network check has not finished, check the IR communication connections.

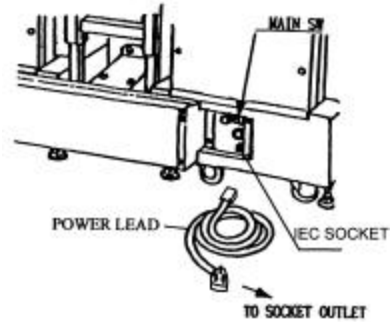

MODE : MASTER
CHECKING NETWORK NOW

NETWORK CHECK SCREEN

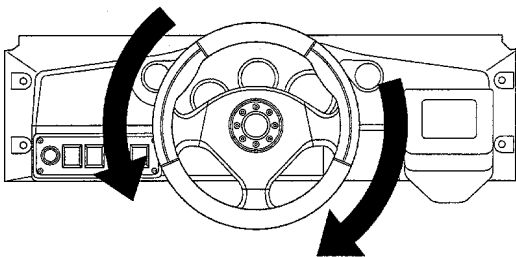

The steering wheel turns left/right automatically.

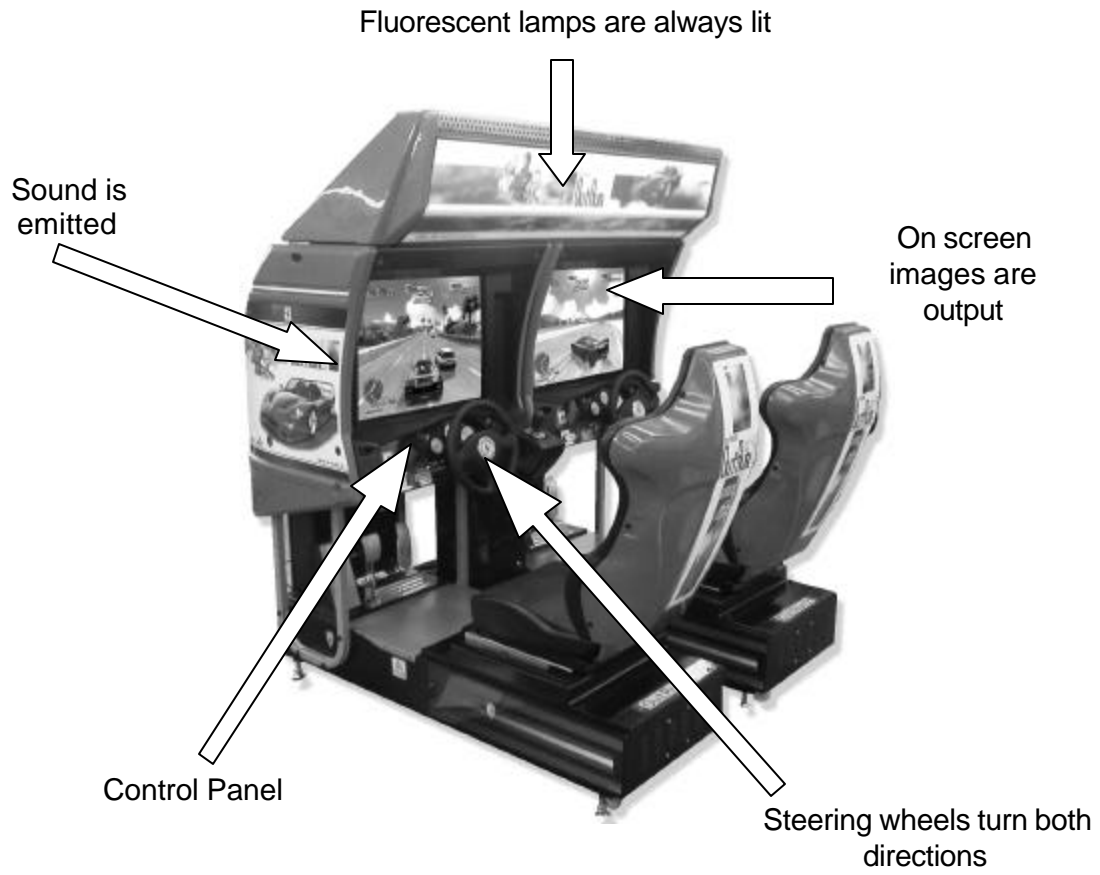

3.7.9. Assembly Check

In the Test Mode, ascertain that the assembly has been made correctly and IC BD is satisfactory (see section 5.2.1).

In the test mode perform the following test:

3.7.9.1.CRT Test



- Only QUALIFIED SERVICE PERSONNEL should carry out this operation.

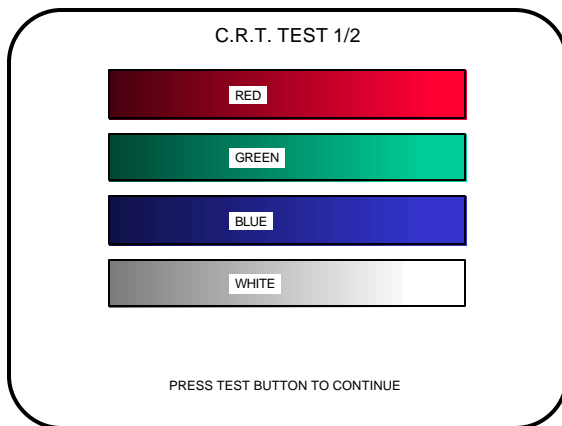

In the TEST mode select CRT test to check the screen is satisfactory.

Although the projector has been set up at the factory before shipment, check to see if the screen needs adjustment.

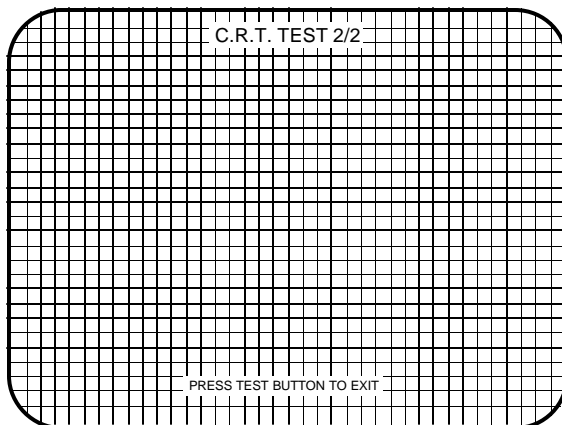

3.7.9.2.Memory Test

Selecting RAM TEST or MEDIA BOARD TEST from the menu screen in System Test mode will cause the machine to automatically perform a test of memory on the game boards. If GOOD is displayed next to the number of each memory segment, the game boards are working properly.

Select SYSTEM INFORMATION to display information on the main game board and the media board. If the information is displayed correctly, this indicates that the game boards are functioning properly.

```
RAM TEST

AUX MEMORY          GOOD

TEST BUTTON TO EXIT
```

```
MEDIA BOARD TEST 1/2

DIMM BOARD(TYPE 3)
VERSION ****
STATUS GOOD
CHECKING 100%

DIMM TEST
DIMM0 - GOOD
DIMM1 - NONE
GD-ROM - GOOD
```

PRESS TEST BUTTON TO EXIT

```
MEDIA BOARD TEST 2/2

NETWORK BOARD
VERSION ****
STATUS GOOD
CHECKING 100%
NETWORK BOARD TEST
RAM CHECK _ GOOD
-- COMPLETED --
```

PRESS TEST BUTTON TO EXIT

```
SYSTEM INFORMATION
MAIN BOARD
REGION ****
BOOT VERSION ****
FIRM VERSION ****
FPGA VERSION ****
SERIAL NO. *****

MEDIA BOARD
DIMM BOARD(TYPE 3) + GDROM
MEMORY SIZE 512MB
FIRM VERSION ****
SERIAL NO. *****

NETWORK BOARD
FIRM VERSION ****
```

PRESS TEST BUTTON TO EXIT

3.7.9.3.Input Test

Select INPUT TEST from the menu screen in either System Test mode or Game Test mode.

JVS TEST	
INPUT TEST	
NODE	1/1
SYSTEM	00
PLAYER 1	1 0000
PLAYER 2	2 0000
COIN 1	1 0000
COIN 2	2 0000
ANALOG	1 0000
ANALOG	2 0000
ANALOG	3 0000
ANALOG	4 0000
ANALOG	5 0000
ANALOG	6 0000
ANALOG	7 0000
ANALOG	8 0000

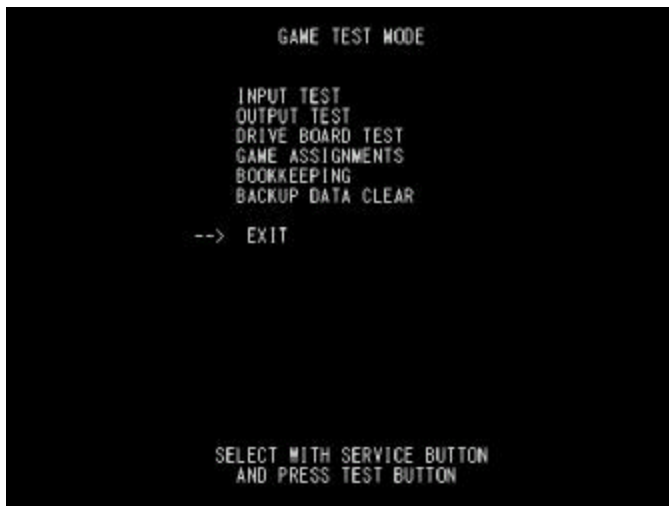

Test the STEERING, GAS (ACCEL) and BRAKE controls to ensure that they are functioning properly and that the parameters change smoothly as each input device is operated.

Display N, UP and DOWN using the GEAR POSITION. N displays that there is no control input. Verify that both UP and DOWN display in sync with the position of the shift knob.

Press the START, CHANGE VIEW, SERVICE and TEST Buttons. If functioning correctly, each indicator will switch from OFF to ON.

Press the SERVICE and TEST Buttons simultaneously to return to the Game Test Menu screen.

3.7.9.4. Output Test

Select OUTPUT TEST to display the following screen and check the status of each lamp. This test should be used periodically to check that the lamps are functioning correctly.

On this screen the cursor will switch automatically between items, lighting up the respective lamps.



- START BUTTON : Lights up the START button.
- VIEW CHANGE BUTTON: Lights up the View Change button.

Press the TEST Button to return to the Game Test Menu screen.

3.7.9.5. Sound Test

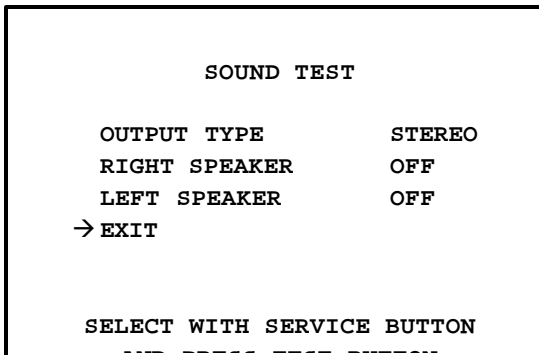

In the system test mode, selecting SOUND TEST causes the screen (on which sound related BD and wiring connections are tested) to be displayed. Check if the sound is satisfactorily emitted from each speaker and the sound volume is appropriate.

3.7.10. Moving The Machine



- When moving the machine, be sure to remove the plug from the power supply. Moving the machine with the plug inserted can cause the power cord to be damaged, resulting in a fire or electric shock.
- When moving the machine, retract the leg adjusters fully and ensure the casters make contact with the floor. During movement pay careful attention so that the casters or leg adjusters do not damage any other cabling laid on the floor. Such damage could result in a fire or electric shock.
- Don't push the cockpit cabinets from the side, as they may topple and cause damage.
- Don't put excessive pressure on the glass or plastic components as damage or personal injury may result if there is a breakage.

- Only QUALIFIED SERVICE PERSONNEL should carry out this operation.

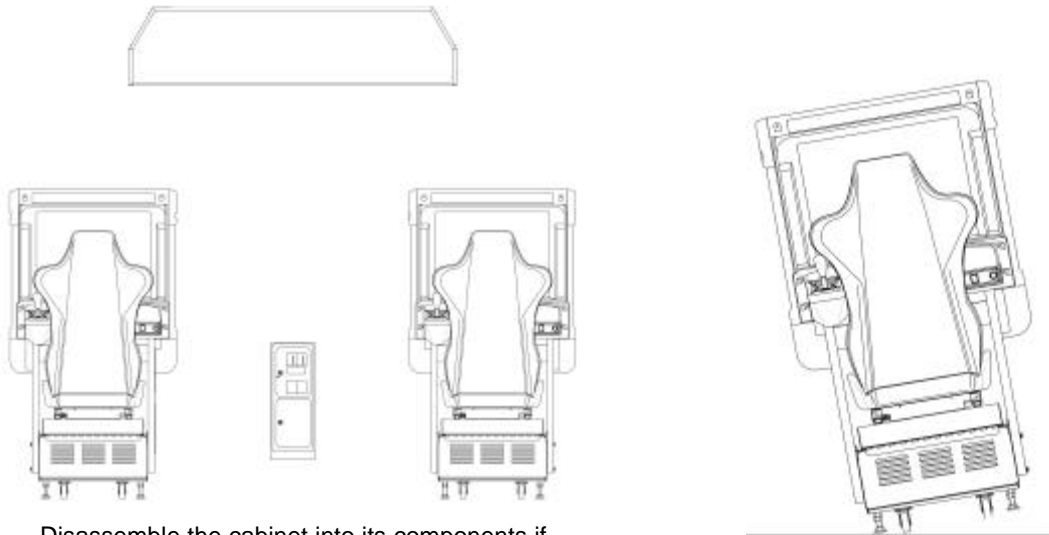

Disassemble the cabinet into its components if transporting up or down step level changes!

Do not push an individual cockpit from the side!

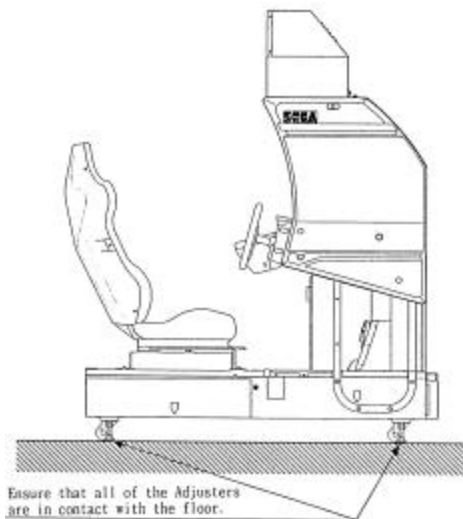

3.8. Fuses



- Never touch places other than those specified. Touching places other than those specified can cause electric shock and short circuit. Disconnect the machine from the supply before attempting the replacement of any fuse.
-
- Only QUALIFIED SERVICE PERSONNEL should replace FUSES.

There are a number of fuses used on this machine to protect the user and the machine from damage. Only replace the fuse once you have remove the cause of its failure. Detailed below is a list of the fuses used, their location and if relevant PCB reference:

PART NUMBER	LOCATION	TYPE & DETAILS	QTY PER COCKPIT
514-5078-10000	IEC INLET (EP1302)	5X20 HRC SB 10000 mA	1 (PER TWIN)
514-5078-6300	838-11856CE-02	5X20 HRC SB 6300 mA	1
514-5078-6300	838-13578(F1)	5X20 HRC SB 6300 mA	1
514-5080-15000	838-14174(F1)	32X6.35 HRC SB 15000 mA	1
514-5078-2500	838-14174(F2)	5X20 HRC SB 2500 mA	1

There are also fuses located on the Monitor PCB. Refer to the relevant Monitor manual supplied to reference these fuses.

RATED VOLTAGE: 220-240 VAC

RATED CURRENT: 3 Amps.

3.9. Maintenance



- Only Qualified Service Personnel must carry out maintenance.
- Ensure that the mains power is switch OFF and disconnected before attempting any work.



- The CONTROL PANEL ASSEMBLY is heavy and may cause injury or damage to the machine if dropped. Use an assistant when removing and replacing it.



- In order to prevent an electric shock and short circuit, be sure to turn power off before performing work by touching the interior parts of the product.
- Be careful not to damage the wires. Damaged wires may cause electric shock or short circuit or present a fire risk.
- Do not touch undesignated places. Touching places not designated can cause electric shock or short circuit.
- This work should be performed by the site maintenance individual or other skilled professional. Performing work by non-technical personnel can cause electric shock hazard.
- Do not perform work other than those specified in this Manual in order to prevent accidents during performing work and operation after performing work. Performing work not specified in this Manual may require special training for this product. If performing work other than those stated in this manual is required for repair, contact the offices herein stated in this manual or where you purchased the product from and ask for repair or inquire how to repair.
- Be very careful when soldering. Handling a soldering iron carelessly may result in a fire or a burn.
- Be extremely careful when heating the heat-shrinkable tube. Failure to do so may result in a fire or burns.



- Do not drop parts when removing them. Dropping parts may damage them or cause sudden accidents.
- To prevent accidents, more than one person must perform these operations.
- Exercise extreme caution when handling the internal parts of the Control Panel. Watch out for damage, warping and loss. The loss of just one piece may result in damage to or lead to faulty operation of the entire unit.
- When securing the plastic-made parts, do not excessively fasten screws and nuts. Failure to observe this may damage the parts and cause injury due to fragments resulting from damage.



- Be sure to perform volume's move value setting in the Volume Setting in the Test Mode after replacing or adjusting the Volume. (See 5.3.1)

3.9.1. Handle Mecha

In the TEST MODE, if the steering wheel V.R. variations are not within the allowable limit, the V.R. installation position requires adjustment or the V.R. needs replacement. Also be sure to apply grease every 3 months.

3.9.1.1. Removing the Handle Mecha

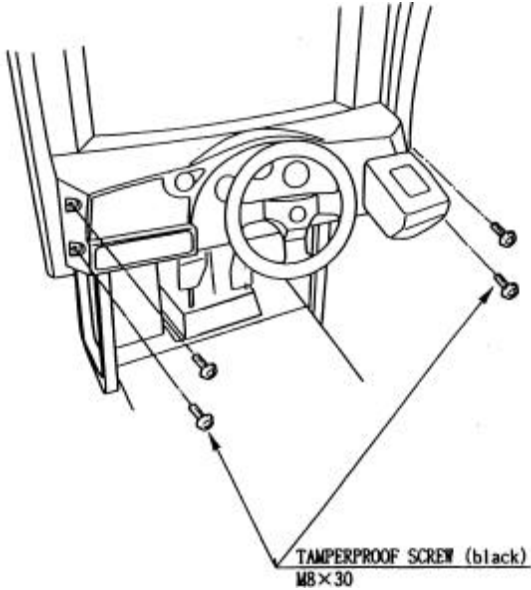

1. Turn the POWER switch OFF
2. Remove a total of 4 tamperproof screws from the Control Panel
3. Wiring connectors are connected inside the Control Panel. Carefully withdraw the control panel in a manner so as not to damage the wiring.
4. Disconnect the wiring connectors and earth harness.

3.9.1.2. Replacing and Adjusting The Handle Mecha's V.R.



- Never touch places other than those specified. Touching places other than those specified can cause electric shock and short circuit.



- After the replacement or adjustment of the V.R. be sure to set the Centre of Steer in the DRIVE BOARD TEST.

3.9.1.3.Adjusting the VR

Remove the CONTROL PANEL as detailed above. Locate the V.R. on the rear surface of the HANDLE MECHA.

1. Using a screwdriver, loosen the 2 machine screws which secure the V.R. Bracket. Move the V.R. Bracket so as to disengage the gears.
2. Gently rotate the V.R. until its value is within the range of the centring position. Position the steering wheel in the centre position.
3. Mesh the gears together. Make sure that a correct amount of backlash is maintained between the gears.
4. If the V.R. value is still not correct make fine adjustments by loosening the 2 machine screws on the V.R. gear. Rotate the gear holder until the correct value is obtained.
5. The value should be adjusted such that with the steering wheel in the centre position the value read during INPUT TEST shall be $80H \pm 10H$.
6. Re-set the centre of steer as described in the game test mode (output test).

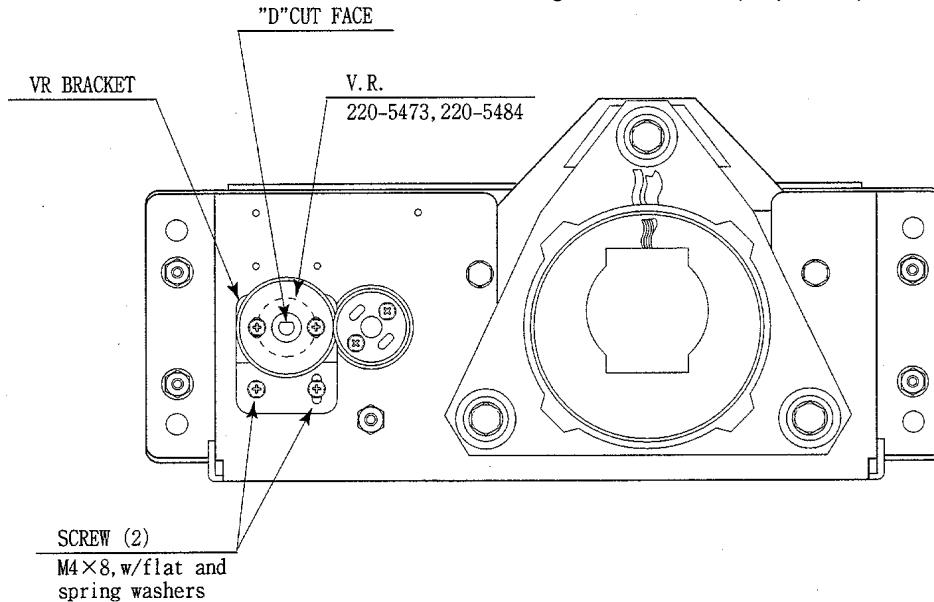

3.9.1.4.Replacing the VR

1. Remove the CONTROL PANEL as detailed above. Locate the V.R. on the rear surface of the HANDLE MECHA
2. Using a screwdriver, remove the 2 machine screws which secure the V.R. Bracket. Remove the V.R. Bracket so as to disengage the gears.
3. Loosen the hexagon drive grub screws in the collar and gently slide off the V.R.
4. Reassemble is the reverse procedure of steps 1 and 2 above.
5. When complete you must readjust the V.R. in accordance with the paragraph above.

3.9.1.5.Greasing



- Be sure to use a good quality, synthetic lubricant. Using a mineral-based lubricant will cause damage to the plastic parts.
- Do not apply lubricant to parts other than those specified. Doing so may cause damage or deterioration of parts.

Apply lubricant to gear mesh portions once every 3 months.

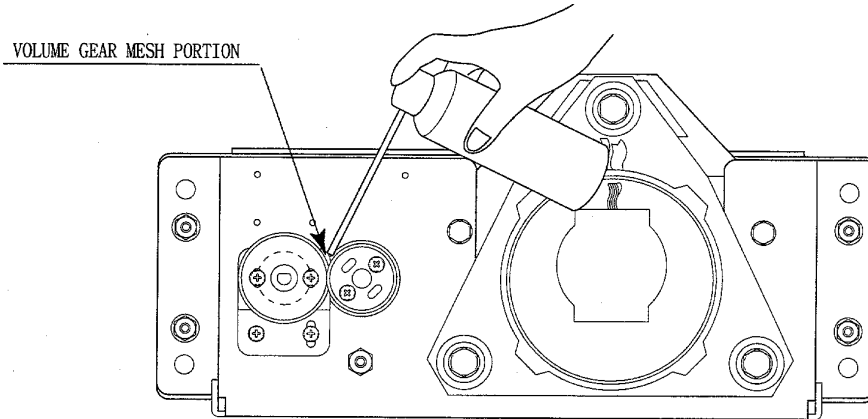

3.9.2. Accelerator & Brake



- Only Qualified Service Personnel must carry out maintenance. Ensure that the mains power is switched OFF and disconnected before attempting any work.

In the TEST MODE, if the brake or accelerator V.R. variations are not within the allowable limit, the V.R. installation position requires adjustment or the V.R. needs replacement. Also be sure to apply grease to all moving parts every 3 months.

3.9.2.1. Removing the Accelerator & Brake.

**HEXAGON BOLT, BLACK (4)
M8 x20 & WASHERS**

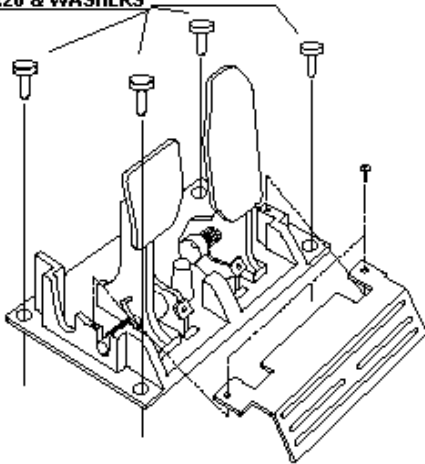

1. Turn the POWER switch OFF
2. Remove a total of 4 screws securing the covers over the ACCELERATOR & BRAKE
3. Fine adjustment of the V.R. values is accomplished with just these covers removed.
4. Coarse adjustment requires the ACCELERATOR & BRAKE mounting bolts to be removed. If this is necessary, remove the bolts from the unit, but do not remove the unit from the machine. Take extreme care when operating the unit in this condition as damage to other components can occur.

3.9.2.2.Adjusting the V.R.



- Never touch places other than those specified. Touching places other than those specified can cause electric shock and short circuit.

- After the replacement or adjustment of the V.R. be sure to set the values in the INPUT TEST.

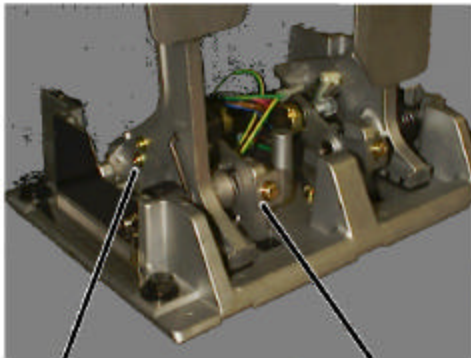

COARSE ADJUST SCREWS

FINE ADJUST SCREW

1. Remove the cover panels as detailed above.
2. Fine Adjustment - By using a screwdriver loosen the 2 machine screws that secure the V.R. arm. Move the V.R. arm to adjust the V.R. value within the relaxed range.
3. Coarse Adjustment - Remove the four hexagon bolts detailed above and remove the side covers of the Accelerator & Brake.
4. Loosen the two machine screws holding the V.R. rack
5. Move the V.R. rack away so as to disengage the V.R.
6. Gently rotate the V.R. until its value is within the range of the centring position.
7. Mesh the gears together. Make sure that a correct amount of backlash is maintained.
8. If the V.R. value is still not correct make fine adjustments as detailed above.

The required values are:

GAS PEDAL:	Under 30H	⇒	Over C0H
BRAKE PEDAL:	Under 30H (THE PEDAL RELEASED)	⇒	Over C0H (THE PEDAL PRESSED)

3.9.2.3.Replacing the V.R.

1. Loosen and withdraw the V.R. rack as detailed above.
2. Using a hexagon key loosen the two grub screws holding the V.R. gear onto the V.R.
3. Remove the V.R. gear
4. Using a spanner remove the nut holding the V.R. in position.
5. Gently remove the V.R. and its wire harness.
6. Refit is the reverse of removal.
7. When complete you must readjust the V.R. in accordance with the paragraph above.

3.9.2.4.Greasing



- Be sure to use a good quality, synthetic lubricant. Using a mineral-based lubricant will cause damage to the plastic parts.
- Do not apply lubricant to parts other than those specified. Doing so may cause damage or deterioration of parts.

Apply lubricant to gear mesh portions once every 3 months.

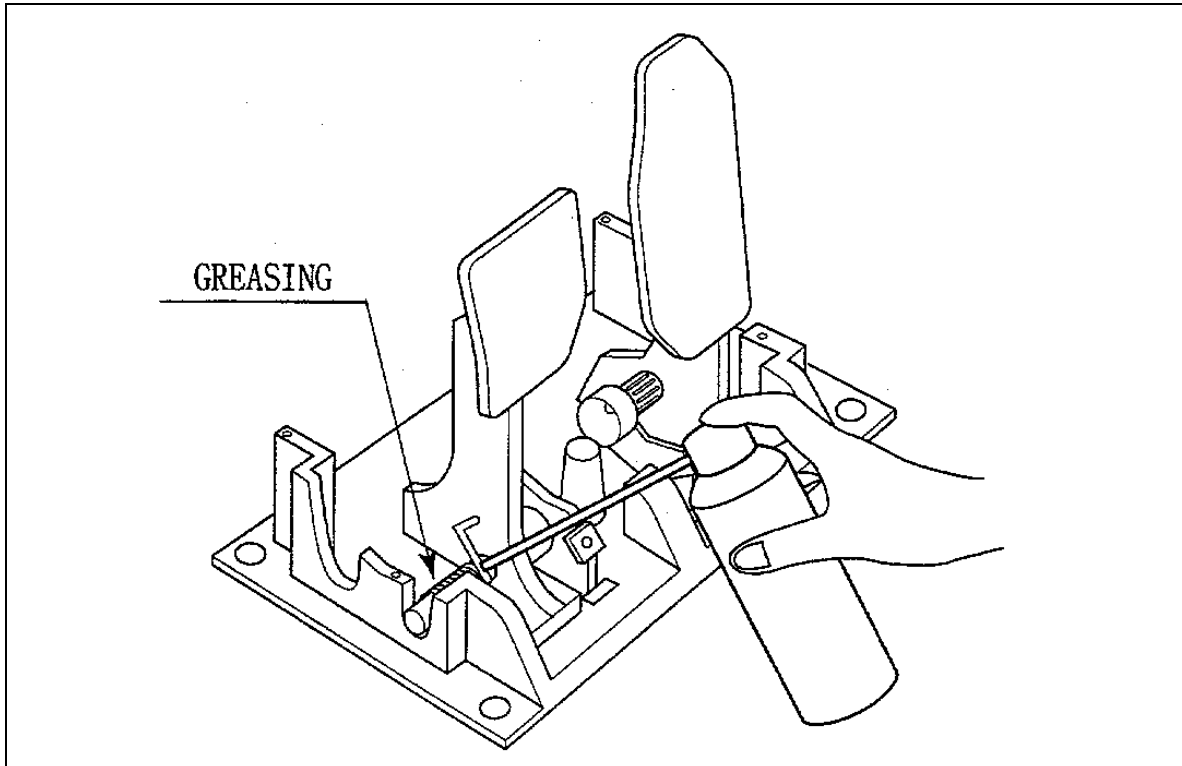

3.10. Shift Lever

In the Test Mode, if the SHIFT LEVER's SW can not be inputted satisfactorily, replace the Switch. Apply greasing to the Mechanism's sliding portion once every 3 months.

When performing the above work, remove the Shift Lever Unit.



- Before starting to work, ensure that the Power SW is OFF. Failure to observe this can cause electric shock and short circuit hazards.
- Use care so as not to damage wirings. Damaged wiring can cause electric shock and short circuit hazards.

REMOVING THE SHIFT LEVER

- Turn the Power SW off.
- Remove the 4 Tamperproof Screws to lift the Shift Lever Unit.
- Disconnect the Connector to remove the Shift Lever Unit.
- When reinstalling, follow the procedure opposite as when removing. At this time, ensure that "DOWN" display appears on the upper part as shown.
- After reinstalling, be sure to check INPUT TEST in the test mode. (TEST.)

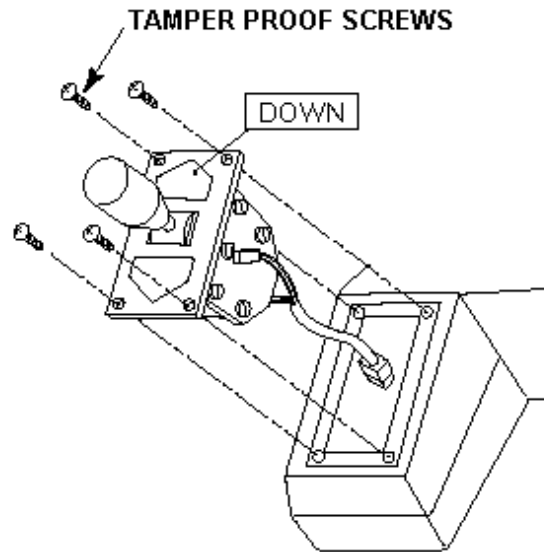

SWITCH REPLACEMENT

- Disconnect the wiring Connector of the Switch to be replaced.
- Remove the 2 Tapping Screws to replace the Microswitch.

GREASING

Apply greasing once in 3 months to the specified portions.

For spray grease, use NOK KLUBER L 60 or Grease Mate (Part No. 090-0066).

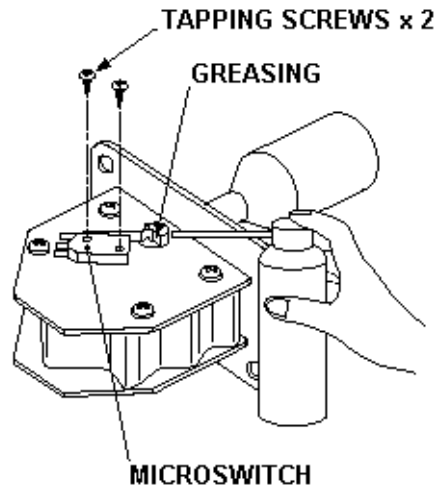

3.11. Replacement of Fluorescent Lamp and Other Lamps



- Never touch places other than those specified. Touching places other than those specified can cause electric shock and short circuit. Disconnect the machine from the supply before attempting the replacement of any lamp.

- Prepare a secure step when working on the upper parts of the machine.

- Only QUALIFIED SERVICE PERSONNEL should replace lamps.

3.11.1. Fluorescent Lamp Replacement

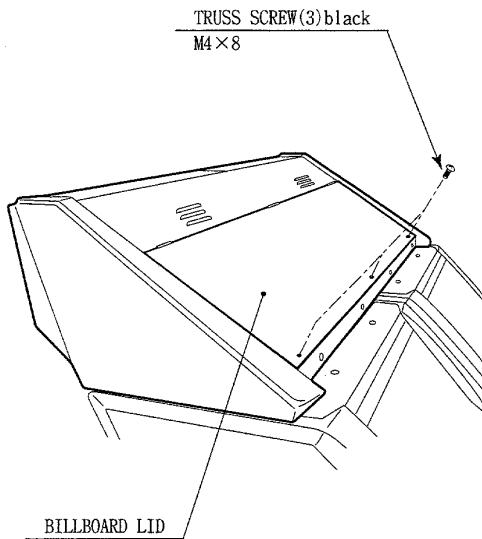

1. Turn the POWER switch OFF.
2. Take out the 3 screws and open the Billboard lid.
3. Remove the end caps from the fluorescent tube.
4. Pull the tube out of the clips with a twisting action.

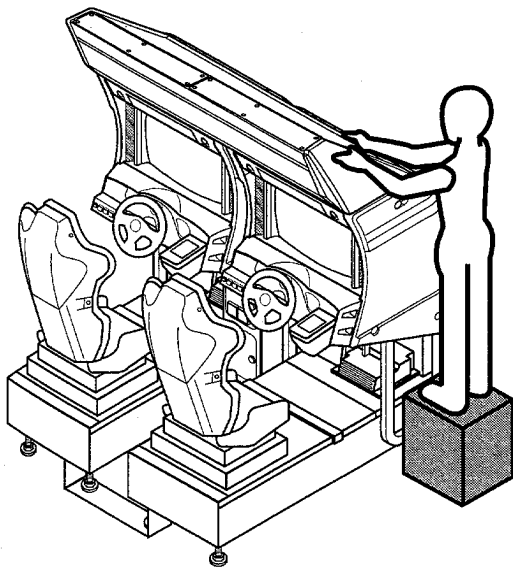

When performing work, be sure to use a step.

FLUORESCENT LAMP 40W

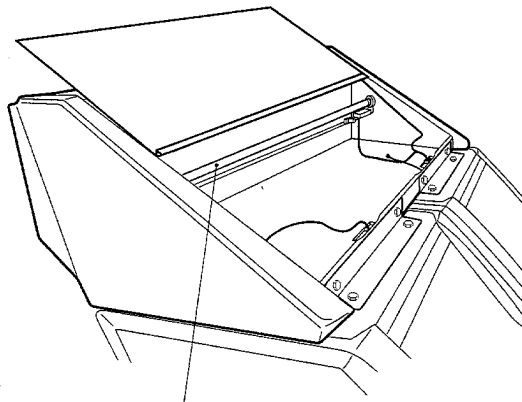

3.12. Cleaning the Cabinet Surfaces

When the cabinet surfaces are badly soiled, remove stains with a soft cloth dipped in water or diluted (with water) chemical detergent and squeezed dry. To avoid damaging surface finish, do not use such solvents as thinner, benzine, etc. other than ethyl alcohol, or abrasives, bleaching agent and chemical dustcloth.

3.13. Seat (Greasing to Seat Rail Portion)

Move the Seat to the rearmost position and apply spray greasing to the portion shown at the right once every 3 months by using NOK KLUBER L60 or GREASE MATE SEGA PART No. 090-0066.

After greasing, move the Seat a few times forward and backward so as to allow the grease to be applied all over uniformly. Be sure to wipe grease which attaches to the surfaces of the PROTECT RUBBER on the Seat Rail, or any excess grease.

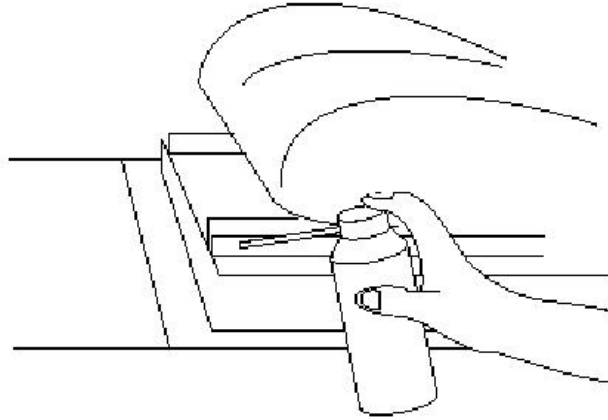

3.14. Troubleshooting



- Only QUALIFIED SERVICE PERSONNEL should carry out these procedures.

3.14.1. Troubleshooting (When No Error Message Is Shown)



- In order to prevent electric shock and short circuit, be sure to turn power off before performing work.
- Be careful so as not to damage wirings. Damaged wiring can cause electric shock or short circuit.
- After removing the cause of the functioning of the Circuit Protector, reinstate the Circuit Protector. Depending on the cause of the functioning, using the Circuit Protector as is without removing the cause can cause generation of heat and fire hazard.
- In the event that a problem cannot be resolved by employing the procedures listed in this Manual, be sure to request service from the office shown on this Manual or the dealer from whom the product was originally purchased. Attempts to employ procedures other than those specified in this Manual can cause electrical shock, shorting, or fire.
- In the event of a problem that is not described here, be sure to contact the office shown on this Manual or the dealer from whom the product was originally purchased. Careless attempts at repair can result in electrical shock, shorting, or fire.

If a problem occurs, first check to make sure that the wiring connectors are properly connected.

PROBLEM	CAUSE	COUNTER MEASURES
When the main SW is turned ON, the machine is not activated.	The power is not ON.	Firmly insert the plug into the outlet.
	Incorrect power source/voltage.	Make sure that the power supply/voltage are correct.
	The fuse of the connect board was blown out due to momentary overcurrent.	After eliminating the cause of overload, replace the specified rating fuse.
Fluorescent lamp inside FL box doesn't light up.	Connector connection fault.	Check connector connections between the Cabinet and the FL box.
	Fluorescent lamp and Glow lamp need replacement.	Replace the fluorescent lamp and the glow lamp (See Section 3.7.9)

PROBLEM	CAUSE	COUNTER MEASURES
Sound is not emitted.	Sound volume adjustment is not correct.	Adjust the Switch Unit's sound adjustment volume . (See Section 5.1.1)
	Faulty connections for various connectors.	Check the connections for the game board, amp, speakers and Volume connectors.
	Malfunctioning BD, Amp. and Speaker.	Perform SOUND TEST. (See 5.2.3)
Sounds are emitted and the lamps are lit, but the screen is black.	Faulty connections for the visual signal connector or the monitor power connector.	Check the connections for the monitor and game board connectors.
	Broken monitor.	Contact the company from whom the unit was purchased.
Irregular/uneven colors on the monitor screen.	Magnetization of the CRT.	Press the Degauss. switch on the VTS Assembly (See Section 5.1.1.)
Colors on the monitor screen are strange.	Faulty connection for the visual signal connector.	Check the visual signal connector connection and make sure it is secured properly.
	Screen adjustment is not appropriate.	Make adjustment appropriately. (See Monitor Manual)
The on-screen image sways and/or shrinks.	The power source and voltage are no correct.	Make sure that the power supply and voltage are correct.
Does not accept input from any switch or volume.	Faulty connector connections.	Check the connection for the I/O Board and Cabinet connector. Check the power for the I/O Board.
Does not accept input from the Shift Lever.	Faulty connector connections.	Check the connections for the connectors in the Control Panel and between the Control Panel and the Cabinet.
	Broken Microswitch.	Replace the Microswitch
STEERING (Servomotor) response is incorrect.	Incomplete power on check.	Power on and verify that the power on check completes properly. (See 3.7.8)
	Deviation of the volume value.	Adjust the volume value in the Test Mode.
	Volume gear engagement fault.	Adjust the engagement of the gear. (See Section 3.9.1.3)
	Volume malfunctioning.	Replace the volume. (See 3.9.1.4)
	Detached wires.	Check for faulty wire connections around moving parts. When replacing wires, secure them so that they do not touch any moving parts.

PROBLEM	CAUSE	COUNTER MEASURES
No response from Steering (Servomotor).	Failure of power-on checking procedure.	Reconnect the power and complete a power-on checking procedure. (See Section 3.7.8)
	Faulty connector connections.	Check the connections for the connectors between the Game Board and Servodriver and between the Servodriver and the Servomotor.
	Thermal element in the Servodriver is operating.	Occurs when the internal temperature reaches 70°C (158°F) and corrects automatically when the unit cools.
	Momentary overload caused a fuse on the Servodriver to blow.	Contact the company from whom the unit was purchased.
Steering (Servomotor) is weak in its force feedback.	Aging of the force feedback mechanism.	Reset in the Test Mode. (See 5.3.1)
Unsatisfactory Accel and Brake operation.	Incorrect volume setting.	Adjust the volume value in the Test Mode. (See 3.9.2.2)
	Faulty Volume attachment or adjust gear alignment.	Adjust the volume attachment and verify in Test Mode. (See Section 3.9.2.2)
	Faulty connector connection.	Check the connections for the Accel and Brake connectors and the connectors between the Accel, Brake and Cabinet.
	Failure of the volume.	Replace the volume. (See 3.9.2.3)
Start button and Change View button input does not work and they do not flash.	Faulty connector connections.	Check the connections for the connectors between the I/O Board, the Cabinet and the Control Panel and those inside the Control Panel.
Start button and Change View button input works, but they do not flash.	Unverified settings or operation.	The Start button only flashes when Free Play is set. Check the operation in Test Mode. (See Section 5.3.1)
	The lamp is burnt out.	Replace the lamp.
Failure of the network play.	Network play is wrongly set.	Reset correctly. (See Section 3.15.8)
	Communication cables are wrongly connected.	Reconnect the cables. (See Sections 3.7.7 & 3.15.8)
	Communication cables are disconnected.	
	Damage of communication cables.	Reconnect cables correctly. (See Section 3.15.8) Replace the cables. Contact the company from whom the unit was purchased.

3.15. Gameboard



- Turn off the mains power and remove the power cord before opening the machine.

- The GAME BOARD should not require any work to be carried out upon it. All settings and tests can be achieved without access to the GAME BOARD.
- All work to be carried out by QUALIFIED SERVICE PERSONNEL

3.15.1. Removing the Board

To return the game board for servicing, take out the board using the following procedure.

1. Turn the main switch OFF.
2. Unlock the base and remove the 2 M6 bolts.
3. Tip the seat carefully backwards as shown. Be careful not to damage the seat back when resting it on the floor. Use a protective mat under the seat back to protect it on hard floors.
4. Disconnect all connectors from the game board, remove the four screws securing the game board to the wooden base, and lift it out. Do not attempt to service the game board. THERE ARE NO USER SERVICEABLE PARTS INSIDE! Return the game board to the Service Department inside the special packaging provided.

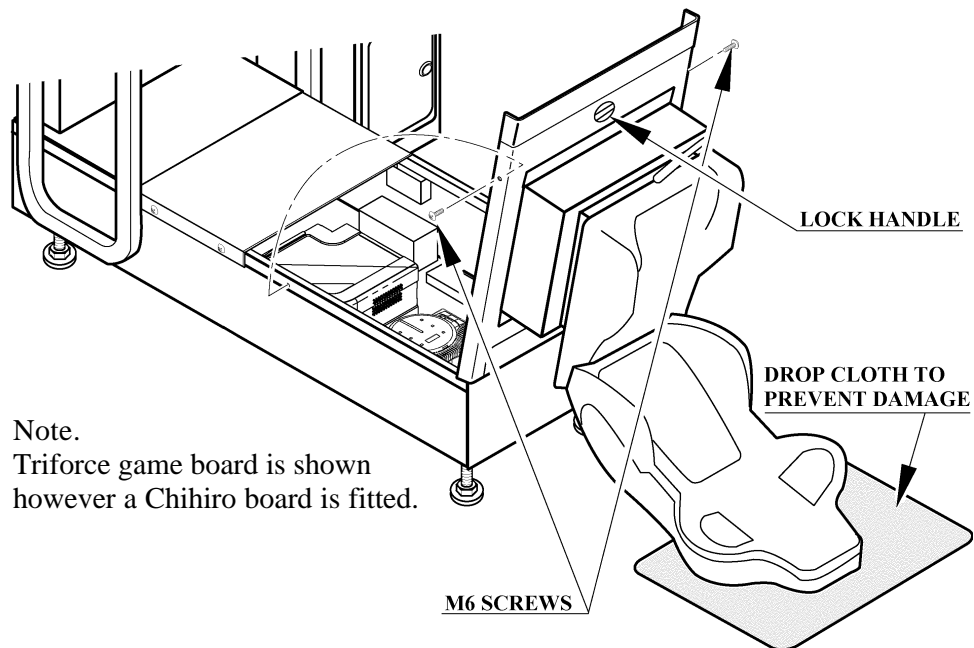

3.15.2. Removing The GD-ROM Drive

1. Turn the power off.
2. Remove 1 truss screw from each side of Base Lid R.
3. Unlock the base with the Master Key.
4. Turn the Lock Handle on Base Lid R to unlock the lid.
5. Lower the seat towards the backrest. Slowly lower the backrest until it touches the floor to prevent damage to the seat part. Put a drop cloth on the floor to prevent damaging the surface of the seat part.

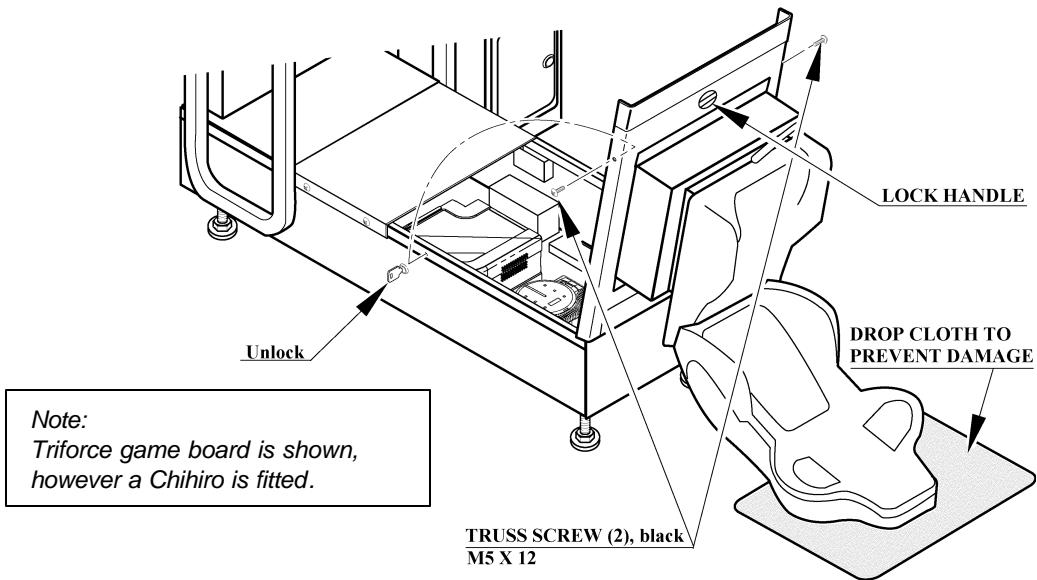

6. Remove the GD cable connector and the power cord connector from the GD-ROM drive.

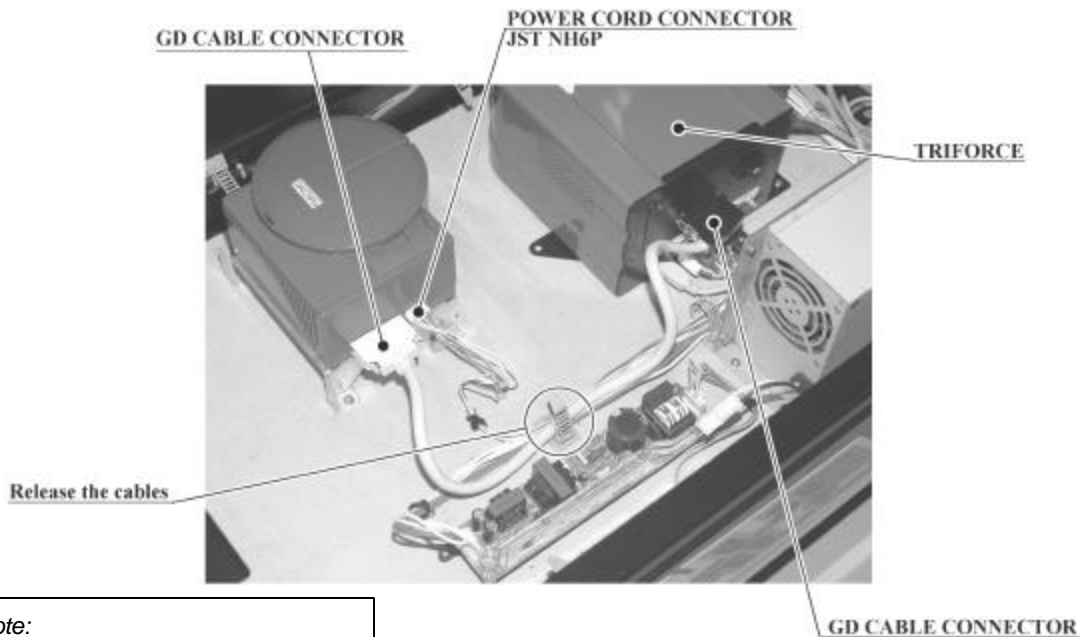

7. Remove the 4 screws to remove the GD-ROM drive.



SCREW (3)
M4 X 16, w/flat & spring washers

Note:
Triforce game board is shown,
however a Chihiro is fitted.

3.15.3. Removing The Game Board



- When returning the game board for replacement or repair, make sure that the connectors are attached correctly. Incorrect connections can lead to accidents such as electric shock, short circuits, and/or fire.
- When plugging in connectors, pay close attention to the direction of the connection. The connectors are designed to be connected in a specific direction. Attempting to plug in a connector by applying excessive force may damage the connector or its terminal clasp, possibly resulting in electric shock, short circuits, and/or fire.

1. Follow the above described action 1 to 5.
2. Remove all the connectors from the game board.
3. Remove the 4 screws that fix the game board.

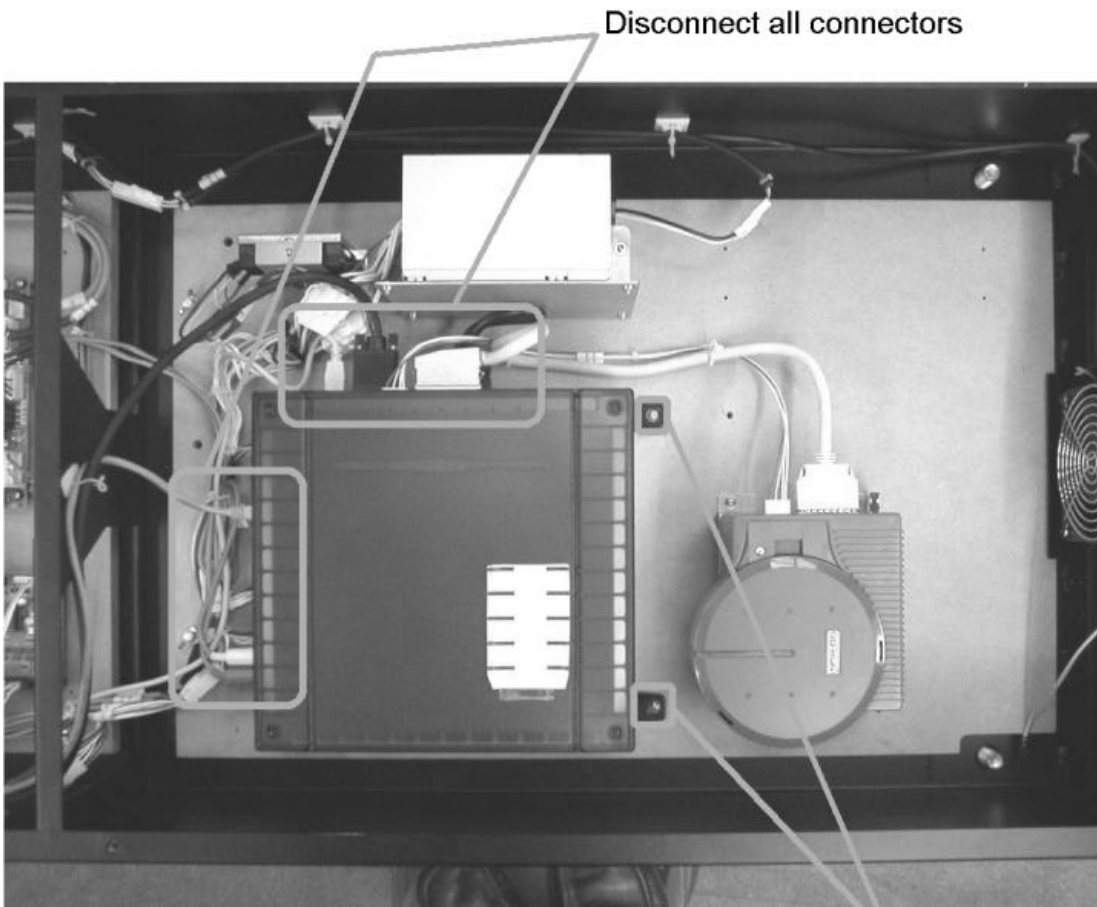

Remove 4 screws (2 on other side of board).

3.15.4.Composition of the Game Board

Once the Chihiro Board has the Key Chip inserted, it is this product's specialized Game Board.

ASSY CASE BOX ORT EXP 843-0005D-02

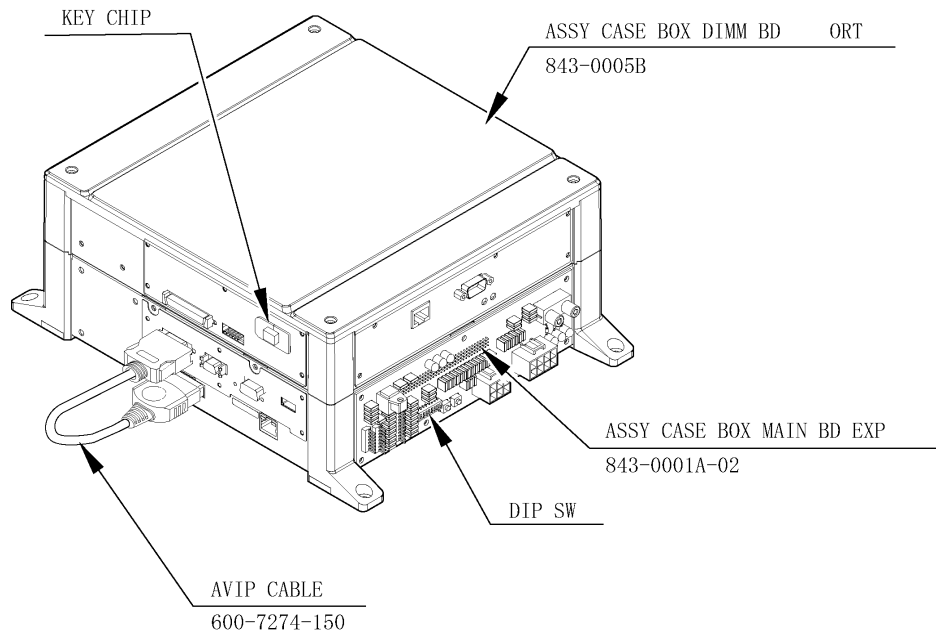

DIP SW SETTING

Use this product with the DIP SW settings shown in the figure below.

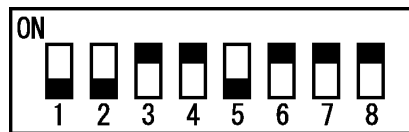

3.15.4.1.Replacing The Main Board Battery



- To prevent overheating, explosion, or fire:
 - Do not recharge, disassemble, heat, incinerate, or short the battery.
 - Do not allow the battery to come into direct contact with metallic objects or other batteries.
 - To preserve or to dispose of the battery, wrap it in tape or other insulating material.
- Follow local regulations when disposing of the battery. Improper disposal can damage the environment.



- To avoid risk of malfunction and damage:
 - Make sure the positive and negative ends are aligned correctly.
 - Use only batteries approved for use with this unit.



- If an error appears indicating that the battery power is very low within the first year of use, it is usually an indication of a problem or abnormality with something other than the battery. Be sure to inspect the board that the battery is connected to.

There is a Media Board Button Battery underneath the Media Board.

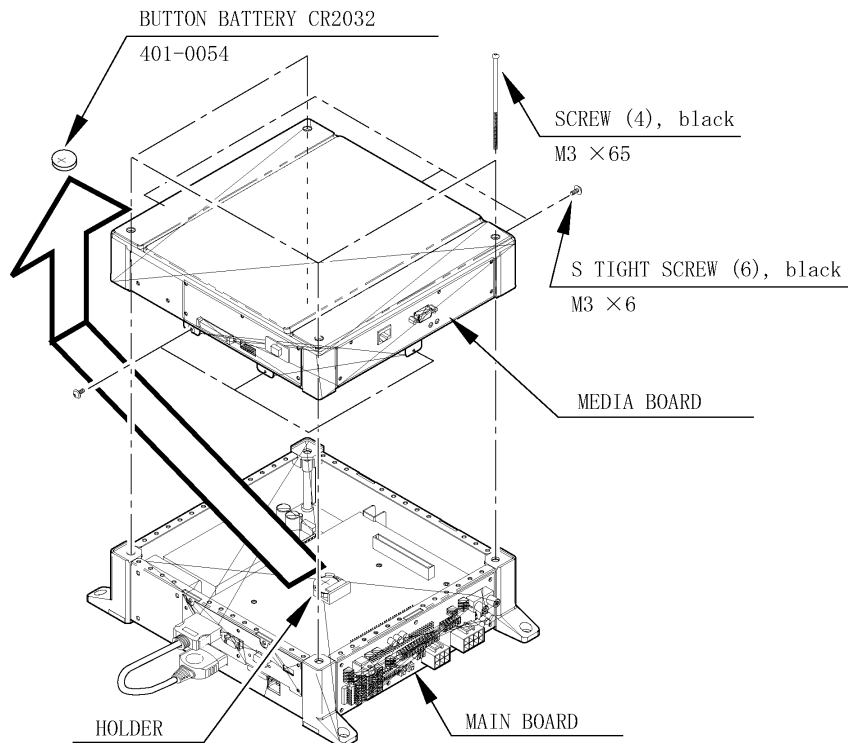

- Carefully remove the battery from its holder.
- Insert a new battery into the holder with the "+" terminal facing up.

3.15.4.2.Replacing The Media Board Battery Pack

Prohibitions and Cautions to Handle the Battery Pack

- Be careful when handling the battery pack.
- We bear no responsibility for problems caused by handling clearly contrary to the content of this manual.



- Do not disassemble the battery pack and the batteries.
- If you should fail to observe this instruction, the internal wires and/or protective devices may be damaged; as a result the safety system may not function when discharging and recharging, eventually causing an overheating, fire and explosion. If you should disassemble the batteries, the generated gases may harm your throat and the negative plate may overheat and make a fire.
- Do not make an external short circuit of the battery pack and the batteries. If you should fail to observe this instruction, the batteries may overheat, make a fire, and explode.
- Do not fire the battery pack and the batteries. If you should fail to observe this instruction, the batteries may make a fire and explode.
- Do not leave the battery pack and the batteries nearby the heat source (fire or heater) or under the intense direct sunlight and flaming sun. If you should fail to observe this instruction, the batteries may reduce the service life and in the worst case may overheat, make a fire, and explode.
- Do not leave the battery pack and the batteries in water or seawater. Also do not apply water or seawater onto the battery pack and the batteries. If you should fail to observe this instruction, the internal wires and/or protective devices may be damaged; as a result the safety system may not function when discharging and recharging, eventually causing an overheating, fire and explosion. Also water may be electrolyzed into oxygen and hydrogen, and eventually the battery's sealed section may be corroded and the internal liquid may leak.
- Do not solder on the battery pack's terminals. If you should fail to observe this instruction, the armor may be heated and melted or the internal wires may be damaged, eventually causing an overheating, fire and explosion. Also, when the battery's temperature reaches to 100° C or more, the battery may leak its internal liquid due to destruction of its plastic parts (gasket, separator, etc.), or may overheat, make a fire, or explode due to internal short-circuit.
- Do not insert or connect the battery in a reversal polarity. If you should fail to observe this instruction, the battery may be externally short-circuited and eventually overheat, make a fire, or explode, depending on the device you connect with.



- Do not tightly seal the battery pack when installing it onto an external device.
- Flammable gas is generated from the battery when its safety mechanism has functioned. If you should fail to observe the above-described instruction, sparks from motors, switches, etc. may cause the gas to fire. Therefore, install the battery pack so that the gas can be quickly released from the external device.
- Do not use the battery pack for the device/usage other than this game system. If you should fail to observe this instruction, the battery and/or the device may be damaged due to non-applicable specifications.
- Do not strike a nail in, hammer, step on, or apply any other forms of pressures and shocks on, the battery.
If you should fail to observe this instruction, the battery may be deformed. As a result, the battery may burst at its sealed sections to leak the internal liquid, or may be short-circuited internally to overheat, make a fire, and explode.
- Do not use a battery charger because any battery charger is not usable for this battery pack.
If you should fail to observe this instruction, the gas may be suddenly generated in the battery and eventually the battery may overheat, make a fire or explode.
- If the battery in use or in keeping shows an abnormal indication (deformation, change of color, bursting of the armor cover, etc.), immediately stop using or keeping it. If it leaks and smells abnormally, immediately keep it away from fire and put it in a safety box.
- If the liquid leaks from the battery and gets in your eyes, do not rub your eyes but immediately wash them with clean water (city water etc.); and consult a medical doctor for a treatment. If you should fail to observe this instruction, the liquid may harm your eyes.
- The battery pack armor (a polyvinyl chloride tube) may be damaged or deformed by external force or heat. When transporting the battery pack or replacing it with a new one, therefore, be careful not to drop or excessively shock it. Do not continue to use any damaged or deformed battery pack. If you should fail to observe this instruction, the battery may overheat, make a fire, or explode.
- The battery pack contains a printed circuit board (PCB) for protective circuitry. It may be destroyed by the static electricity. When handling or servicing the battery pack, therefore, take preventive measures against the static electricity.
- If your battery pack has shown destruction of a protective circuitry PCB, do not continue to use it. If you should fail to observe this instruction, the battery may overheat, make a fire, or explode.
- When wiring the battery pack to a device, be careful not to apply excessive force onto the connectors and lead wires. The battery may overheat, make a fire, or explode if the connectors and lead wires are damaged.
- When discarding the battery pack at a disposal specialist, be sure to cover the terminals with tape or some other covering and avoid damage when packing.



- Do not do away with the used battery packs carelessly because they may contaminate the environment. Be sure to dispose of the used battery packs in accordance with the laws/regulations of your country.

If the GD-ROM read time becomes excessively long, it is likely that the Media Board battery pack life is running low.

No battery pack charger is available.

Follow the procedure to replace the battery pack:

1. Remove 4 screws from the upper face of the board.
2. Remove the top cover.
3. Remove 1 tapping screw and remove the cover battery holder.
4. Disconnect the connector at the end of the wire coming out of the battery pack. Remove by pressing the projection on the connector and pulling.
5. Securely connect the new battery pack.
6. Attach the cover battery holder and top cover.

Submit the used battery packs to an industrial waste disposal plant. Thus they must be disposed according to the local laws and the regulations in your country.

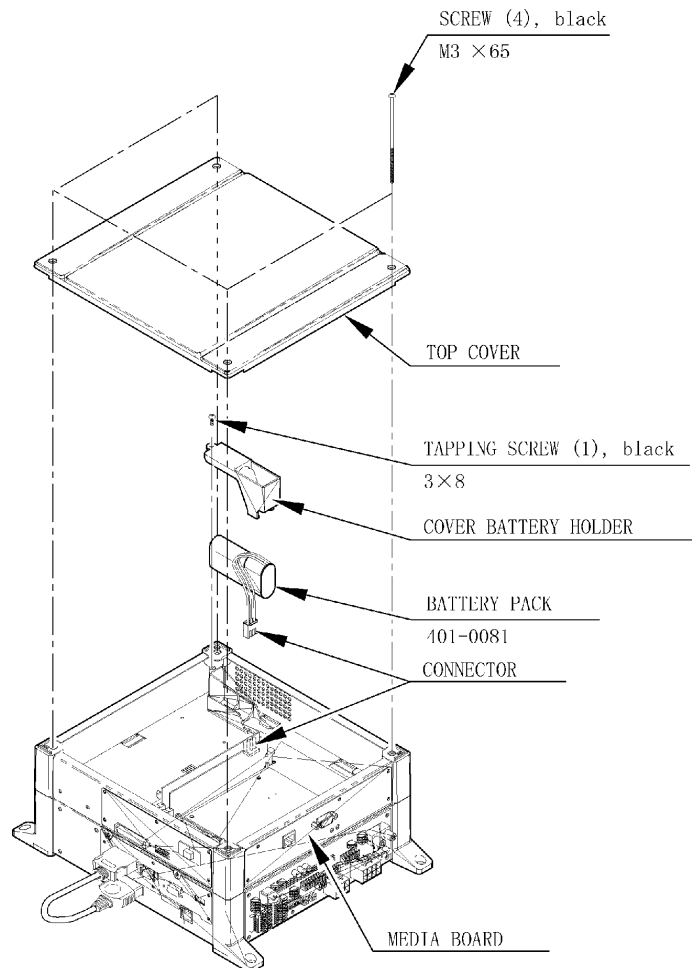

3.15.5.Shipping The Game Board

 <p>STOP IMPORTANT</p>	<p>Replacement or repair of the Game Board (Chihiro) for this product should be undertaken at the appropriate repair centre. Be sure to follow the specifications below when requesting repairs/sending the board to the repair centre. Not following the specifications may result in the board not being accepted or in extra charges being made.</p> <ul style="list-style-type: none">• Put the game board in the carton box as is. Do not carry out any disassembly or part removal other than that specified.• Follow the procedure and instructions regarding direction below when placing the Game Board in the carton box.• When packing the game board with the Media Board attached, do not remove the Key Chip.• When packing the game board with the Media Board detached, be sure to include the AVIP Cable.• When packing, attach the accessory stickers in the specified places on the Game Board and carton box.
---	---

INSTRUCTIONS

1. Wrap the Chihiro Board in a plastic bag.
2. Place it on top of the bottom surface cushioning material. Turn the Filter Board to face the side with the three honeycomb buffers. Packing it in the opposite direction may cause damage to the Filter Board.
3. Insert corrugated cardboard into the space between the lateral honeycomb buffers of the bottom surface cushioning material and stow the AVIP cable inside.
4. Place the Chihiro Board wrapped in the bottom surface cushioning material into the carton box. Use the handles on the bottom surface cushioning material.
5. Place the upper surface cushioning material on top of the Chihiro Board. Be sure to align it in the right direction, as it will not fit otherwise.
6. Close the top of the carton box and seal it tightly with adhesive tape.

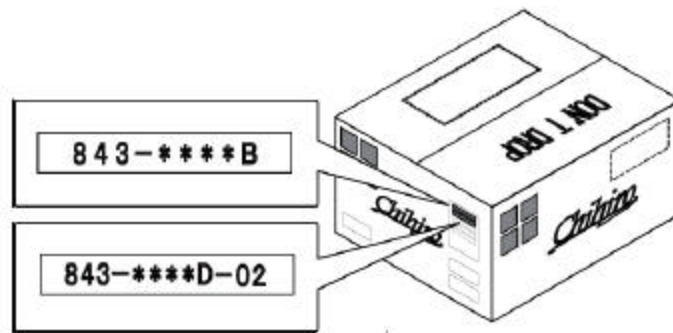
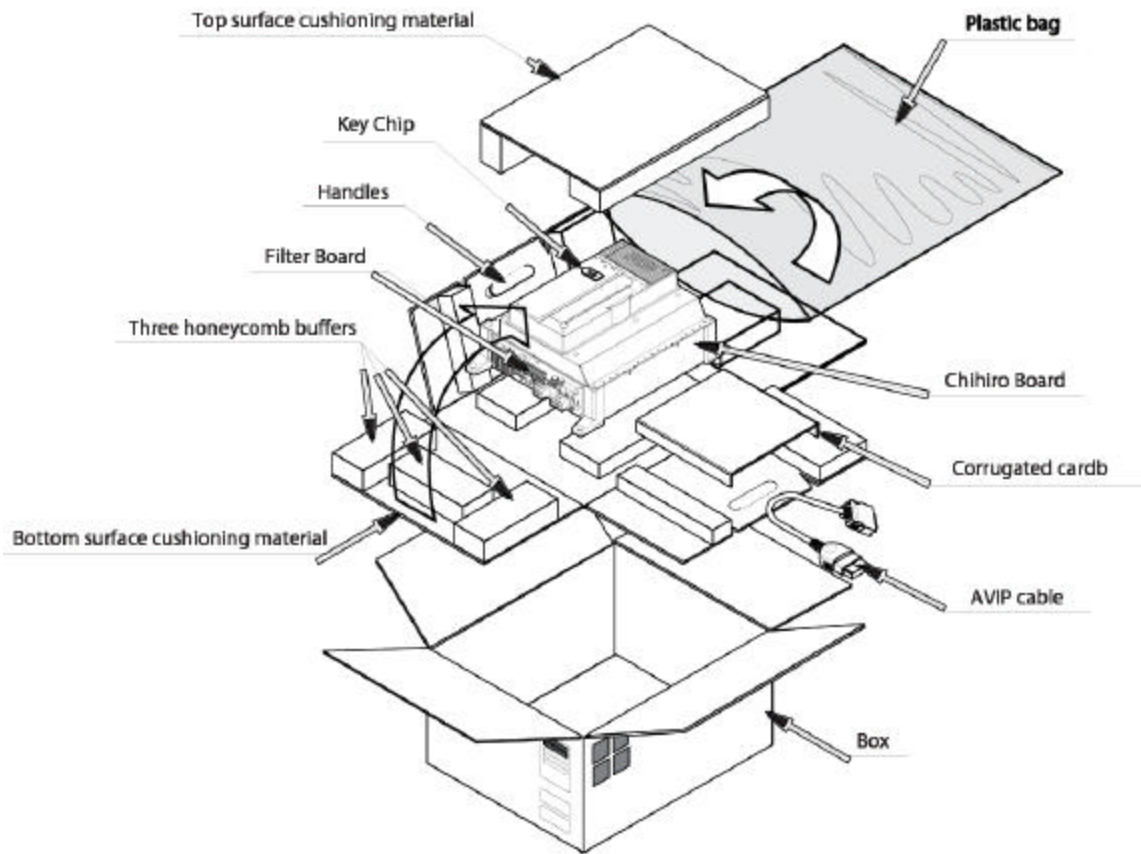

3.15.6. Shipping The Media Board



When sending the Media Board for repairs, follow the specifications below and request repairs or send the Board to your retailer/the repair centre.

Not following the specifications may result in the board not being accepted or in extra charges being made. Also, mistaken handling can damage or result in loss of parts.

- Be sure to use the special purpose carton box included with this product.
- Do not remove the Key Chip. Send the board with the Key Chip attached.
- Undo the 10 screws holding the Media Board to the Main Board and pack the Media Board. Do not carry out any disassembly or part removal other than that specified in this manual.
- Pack the Media Board in the special purpose carton box as shown in the explanatory diagram.
- The packing material in the carton box has a shock absorbing function. Be sure to use it when packing. Do not bend or fold the material in a direction other than that shown on the diagram.
- Do not pack any wires, cables, or screws together with the Board.
- Be sure to attach the special purpose carton box accessory sticker "843-****B."

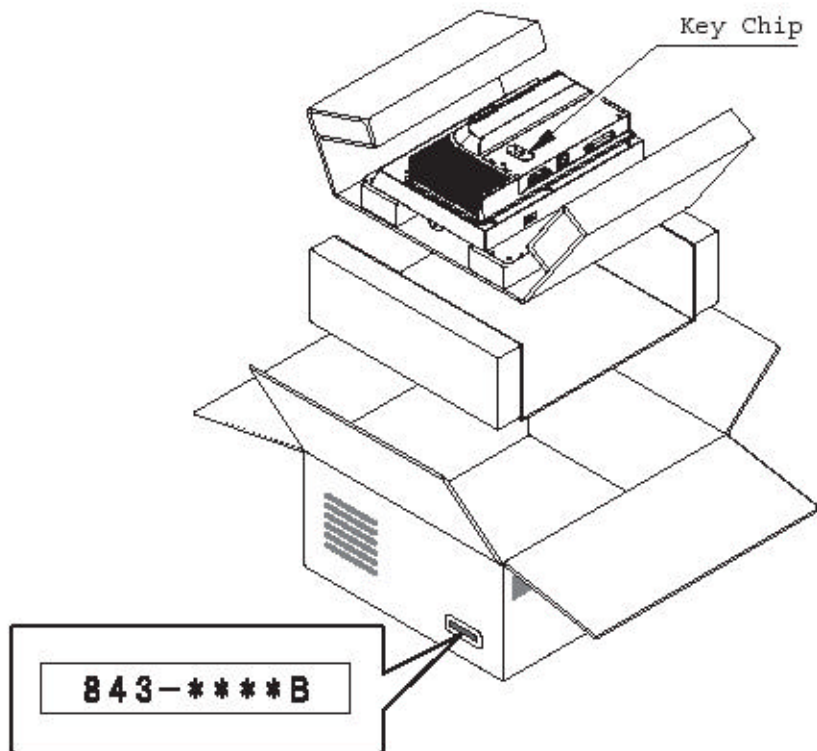

3.15.7. Shipping The GD-ROM Drive



- When returning the GD-ROM DRIVE for repair or replacement, be sure to package it in the original card transit box - THERE ARE NO USER-SERVICEABLE PARTS INSIDE.
- Ensure the GD-ROM Disk is removed and the GD-ROM Drive Lid is replaced on the unit, with fixing screw, before packaging. Also, remove the GD-ROM Drive Bracket and store with the four screws for reuse.
- Failure to return the GD-ROM DRIVE in this manner may invalidate the warranty.

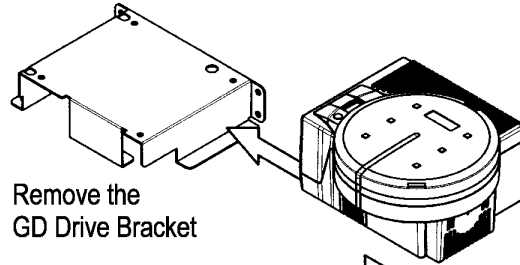

Remove the
GD Drive Bracket

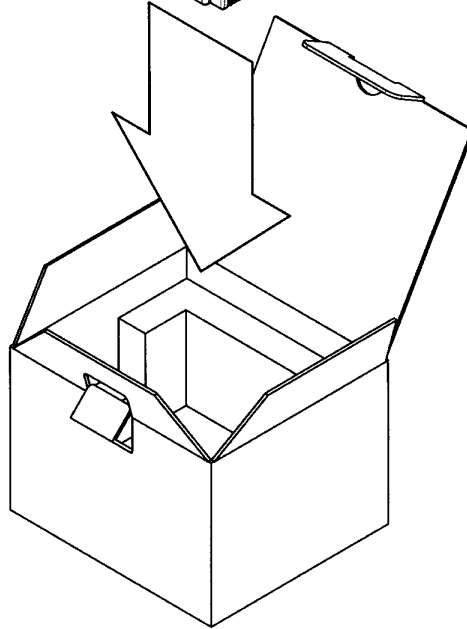

3.15.8. Machine Set Up

During linked play, if the test mode is not finished within three minutes on all linked machines, the NETWORK CHECK cannot be performed, causing a NETWORK ERROR.

First, set up each linked machine to meet the requirements of communication play. If the settings are incorrect, communication play is not possible.

SYSTEM ASSIGNMENTS	
CABINET TYPE	1PLAYER
ADVERTISE SOUND	ON
MONITOR TYPE	HORIZONTAL
SERVICE TYPE	COMMON
> EXIT	

SELECT WITH SERVICE BUTTON
AND
PRESS TEST BUTTON

3.15.8.1. Network Play

Up to 4 machines can be linked for network play. Properly connected network cables and correct network play settings are required for network play.

3.15.8.1.1. Precautions Regarding Network Play Setup



- Before starting to work, ensure that the Power SW is OFF. Failure to observe this can cause electric shock or short circuit.
- Use care so as not to damage wirings. Damaged wiring can cause electric shock or short circuit.
- Do not touch undesignated places. Touching places not designated can cause electric shock or short circuit.
- This work should be performed by the site maintenance individual or other skilled professional. Performing work by non-technical personnel can cause electric shock hazard.
- When linking a number of machines, be sure to supply sufficient power for the corresponding number of machines. Be sure to secure per machine current as stated in this manual. Failure to observe this can cause a fire and an electric shock accident.
- Due to the length of the network cable, the distance in between the machines is limited. However, to avoid accidents, be sure to secure space in excess of 70 cm between the machines.
- To perform work safely and avoid serious accident such as the cabinet's falling down, do not perform work in places where step-like grade differences, a ditch, or slope exist.



- To perform work safely, be sure to secure the space corresponding to number of machines to be linked. Failure to observe this can cause accident.
- To avoid accidents, use a cable cover that will not cause patrons to trip when laying network cables in areas of heavy foot traffic.
- To prevent accidents and acts of vandalism, cover the network cables with the strongest cover possible.



- Network play is not possible between game machines with different cabinet types.

When connecting several games machines together, make sure that a sufficient amount of electrical power is available for each machine. Plan on providing 15A for each machine in 100-120V locations, and 7A in 220-240V locations.

3.15.8.1.1. Spacing of Game Machines

Leave at least 70 cm of space between game machines.

SPACING OF GAME MACHINES

BE SURE TO SECURE SPACE IN EXCESS OF THE DESCRIBED DISTANCE BETWEEN THE MACHINES.

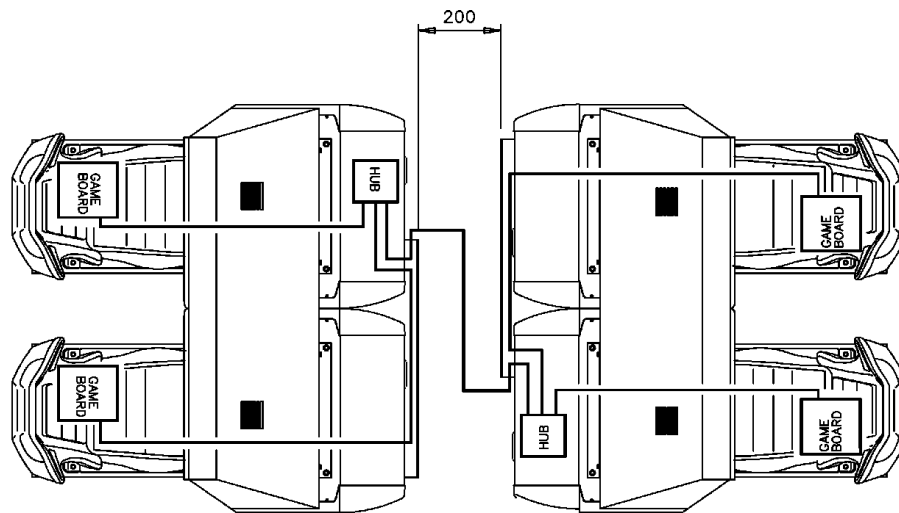
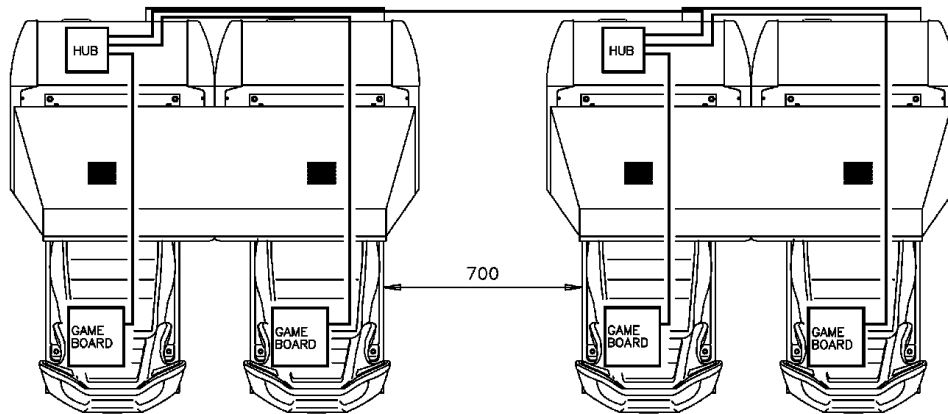

3.15.8.1.2.Connecting Network Cables

To enable network play, the hubs inside each of the game machines involved must be connected with network (LAN) cables. Connect the hub inside one of the machines to the hub in the other machine using LAN cables. There is no need to connect the other machines to each other in any other way.

Do not connect LAN cables between twin machines when they are not used for network play.

1. Turn off the power and unplug the power cord from the outlet. Place the power cord so as not to damage it while working.
2. Using the illustration on the previous as reference, move the machines so that they are lined up. Leave enough space on the front lid side of the machine to perform the rest of the operations in this procedure.
3. Remove the lower back lids of machines denoted 'L' on back.

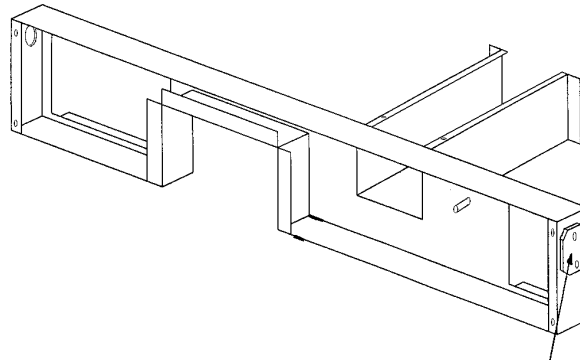

Hole Lid

4. Remove the front covers on both machines.
5. Take off the required hole lids at the ends of the AC covers (see diagram above).
6. Route a spare LAN cable through both machines connecting both hubs.
Any of the ports 2 or above can be used to connect to any of the other game machines.
7. Replace all lids and covers.
8. Once the machines have been linked for network play, line them up. Leave as much space as possible between the machines.
9. Secure all adjustors on each machine. (See Section 3.7.3)
10. Connect the power cord and grounding wire for each machine. (See 3.7.8)

3.15.8.1.3.Network Play Settings

Each of the linked machines must be set up for network play. If the machines are not set up correctly, network play will not be possible.

3.15.8.1.3.1.How To Set Up A Machine For Network Play

1. Turn off the power on each machine to be used in network play.
2. Enter Test mode on each machine. (See Section 5.1)
3. Select GAME TEST MODE and press the TEST Button. The machine will enter Game Test mode and the screen will display the Game Test menu. (See Section 5.3)
4. Select NETWORK SETTINGS from the Game Test menu and press the TEST Button. The Network Settings screen will appear. Network settings are carried out on this screen.

```
NETWORK SETTING

LINK NUM 2(2•`4)
GROUP A(A•`Z)
NUMBER 2(1•`4)
-> EXIT

SELECT WITH SERVICE BUTTON
AND PRESS TEST BUTTON
```

5. Set the LINK NUM setting on the Network Settings screen to the number of game machines linked for network play.
6. Set up the GROUP setting on the Network Settings screen. The GROUP setting is used to divide the machines linked for network play into groups. For example, a network of 4 machines could be divided into 2 groups of 2 machines.
7. Set the NUMBER setting on the Network Settings screen so that each machine within a group has a different number. Make sure that one machine in each group is set to "1".
8. Exit Test mode on each machine. Be sure to choose EXIT from the System Test Menu to exit Test mode properly.
9. Once each machine has exited Test mode and gone through initialization, it will begin a network test. During the network test, the monitor will display a network test screen.
10. If there are no problems with network play settings or cable connections, the machine will enter Advertising mode.
11. If the advertising screen appears after the network test is finished, network settings are complete.
12. The network test should last roughly 20 to 30 seconds. If the network test screen fails to disappear, the problem is most likely due to one of the following: incorrect settings, an improperly connected LAN cable, a faulty LAN cable connection, or a severed wire.

3.15.8.1.4.General Precautions Regarding Network Play



- When setting up machines for network play, settings such as the game's difficulty level will be derived from the machine whose "NUMBER" is set to "1". If settings on machine "1" are changed, the other machines will have their settings changed accordingly. On machines other than "1", settings derived from machine "1" will not be displayed on screen and cannot be changed.
- Should a network connection fail during network play, gameplay will be suspended and the Network Error Screen will be displayed.
- If one of the units attached for network play enters Test Mode, the other unit will display the same Test Mode Screen.
- Even when units are connected for network play, each seat, each game may be given different cost settings. Incorrect cost settings may cause budget balancing problems.

Note that when 2 or more machines are linked together for network play, some functions are different than for stand-alone machines.

Whenever Test mode is used on a machine linked for network play, all machines connected to the network will display the network test screen. When patrons are engaged in network play, do not enter Test mode on any of the machines in the network, even if the machine is not in use.

However, machines whose GROUP setting is different from that of the machine entering Test mode will not be affected.

3.16. Periodic Check and Inspection

The items listed below require periodic check and maintenance to retain the performance of the machine and ensure safe operation:



WARNING!



IMPORTANT!

- Be sure to check annually to see if the power cords are damaged. The plug is securely inserted and that there is no dust in the interior of the machine or between the socket and the power cord. Using the product in an unclean condition may cause a fire or electric shock.
- Periodic checks should only be carried out by QUALIFIED SERVICE PERSONNEL.

DESCRIPTION	WHAT TO CHECK	INTERVAL
HANDLE MECHA	Check the V.R. value	Monthly
	Check adjust gear engagement	Every 3 months
	Greasing of gears	Every 3 months
ACCELERATOR & BRAKE	Check the V.R. value	Monthly
	Check adjust gear engagement	Every 3 months
	Greasing of gears	Every 3 months
SHIFT LEVER	Check SW	Monthly
	Greasing	Every 3 months
MONITOR / PROJECTOR	Clean screen (do not use water jet)	Weekly
	Check adjustment	Monthly
SEAT	Rail greasing	Monthly
GAME BD	Memory Test	Monthly
	Game Assignments	Monthly
INTERIOR	Clean (do not use water jet)	Annually
POWER SUPPLY CORD	Check condition	Annually
CABINET SURFACE	Clean (do not use water jet)	As required
CONTROL PANEL	Lamp operation	Monthly
	Check switch operation	Monthly
COIN MECHANISM	Check SW (If Fitted)	Monthly

4. HOW TO PLAY

4.1. Basic Controls

Insert a coin and press the Start / Credit Button to begin a game.

Choose your car, background music, and other options. View choices with the Steering Wheel, and enter your selection with the Gas pedal.

During game play, use the Gas pedal to accelerate your car, and the Brake pedal to stop. The Gear Shifter can be used to shift up and shift down when using Manual transmission.

You can switch between three different view settings with the View Change Button.

4.2. Game Outline

This is a driving game.

The player controls a car (Ferrari), listening to great music and enjoying roadside scenery in the company of a gorgeous female passenger, all while racing towards the goal before time is up.

The time limit is extended at each checkpoint.

The game ends when the player runs out of time or reaches the goal.

Each game stage ends with a fork in the road where the player must decide the route using the car during the race. There are a total of fifteen stages, and five separate goal areas.

The three single player game modes are OutRun Mode, Heart Attack Mode, and Time Attack Mode.

The game's Versus Mode accommodates play for up to four players.

Route Guide with Stage Names

					5A	Tulip Garden	
				4A	Cloudy Highland		
		3A	Castle Wall		5B	Metropolis	
	2	Deep Lake		4B	Industrial Complex		
1	Palm Beach		3B	Coniferous Forest		5C	Ancient Ruins
A		2B	Alpine		4C	Snow Mountain	
			3C	Desert		5D	Imperial Avenue
				4D	Ghost Forest		
					5E	Cape Way	

4.3. Game Flow

4.3.1. Versus Mode Entry

After inserting coins and pressing the Start Button, Versus Mode Entry prompts will be displayed for potential players at other game cabinets. Pressing the Start Button within the Versus Mode Entry period will start Versus Mode.

Closing Versus Mode Entry

To close Versus Mode entry, press the View Change Button and the Brake pedal at the same time before other players join. (Press the Brake pedal while holding down the View Change Button.)

Versus Mode entry time can also be run down to 0 by holding the Start Button, thus closing Versus Mode entry.

By closing Versus Mode entry in either of the above ways, the Single Player mode will commence, provided no players have already joined.

4.3.2. Car Selection



You can select the car model. In Single Player mode you can also change the car colour. Press the Brake pedal and Shifter together to change the car colour. (Press up or down on the shifter while holding down the Brake pedal.) These instructions will not be displayed on the screen.

Moving the Shifter up or down while holding down the Brake pedal will bring up a two-character car colour code just above the 'Gas Pedal: Enter Selection' indicator in the lower right corner of the screen. The colour codes are represented as follows: RE:red, YE:yellow, BK:black, WH:white, SL:silver, GR:green, LB:light blue, BU:blue.

Changing the car model in the middle of colour selection will automatically return the colour to the selected model's default colour, after which model and colour selection will again be possible. The selected car will then be displayed in the chosen colour at the start of the game.

The available colours vary from car to car. The colours available for each car are indicated by a 'Yes' in the chart below, and likewise, only these colours will be shown during selection.

Colour Chart

Car Type	Black	Blue	Green	Light Blue	Red	Silver	White	Yellow
F50	Yes	Yes	Yes	Yes	Yes	Yes	Yes	Yes
360 Spider	Yes	Yes	Yes	Yes	Yes	Yes	Yes	Yes
Dino 246 GTS	Yes	No	No	Yes	Yes	Yes	Yes	Yes
365 GTS/4 Daytona	Yes	No	No	Yes	Yes	Yes	Yes	Yes
Testarossa	Yes	No	No	No	Yes	Yes	No	Yes
288 GTO	Yes	No	No	Yes	Yes	No	Yes	Yes
Enzo Ferrari	Yes	No	No	No	Yes	Yes	No	Yes
F40	Yes	Yes	Yes	Yes	Yes	Yes	Yes	Yes

Player-selectable cars and their characteristics are shown below. The colour shown in parenthesis is the default colour.

F50 (RE), 360 Spider (RE)
(For INTERMEDIATE Player)

Acceleration : *****
 Handling : *****
 Top Speed : *****

Dino 246 GTS (YE), 365 GTS/4 Daytona (BK)
(For NOVICE Player)

Acceleration : *****
 Handling : *****
 Top Speed : *****

Testarossa (RE), 288 GTO (RE)
(For INTERMEDIATE Player)

Acceleration : *****
 Handling : *****
 Top Speed : *****

Enzo Ferrari (RE), F40 (RE)
(For PROFESSIONAL Player)

Acceleration : *****
 Handling : *****
 Top Speed : *****

4.3.3. Transmission Selection

You can choose between Automatic transmission and Manual transmission.

When Manual transmission is selected, the number of gears varies with the car model.

- 6-speed: F50, 360 Spider, Enzo Ferrari
- 5-speed: Dino 246 GTS, 365 GTS/4 Daytona, Testarossa, 288 GTO, F40

4.3.4. Mode Selection

In Single Player, you will choose a game mode.

4.3.4.1. OutRun Mode

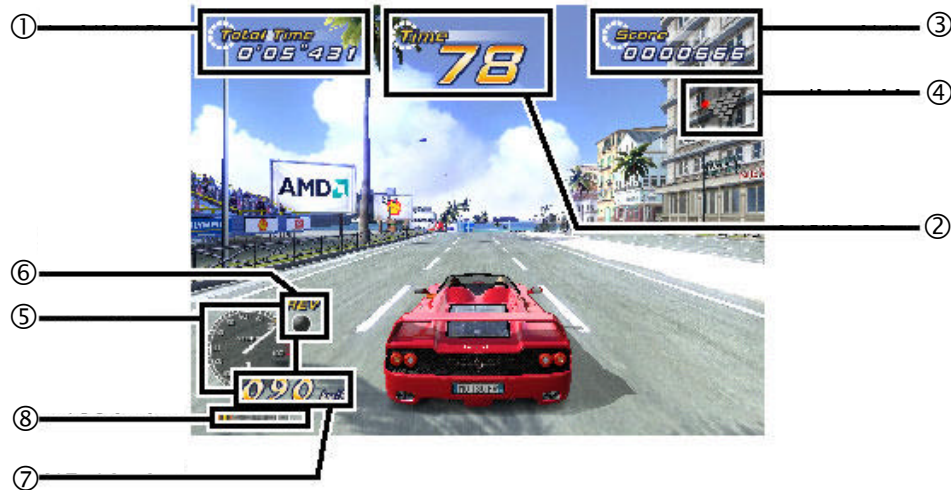

- 1) Total Time
- 2) Time Counter
- 3) Score
- 4) Route Map
- 5) Tachometer
- 6) Shift Up Indicator
- 7) Speed Meter
- 8) Shift Indicator

This is the pure driving mode, enjoyed with a young lady by your side. You select branching paths and try to reach the goal within the time limit. The game ending varies depending on which goal is reached.

4.3.4.2.Heart Attack Mode



1) Lady's Heart Meter

This is the mode where you raise the Lady's Heart Meter by fulfilling her requests. Collect as many of the hearts showing her feelings as possible. You must pursue her request for the duration of the indicated track section.

The Lady's Requests

- 'Drift more!' Try drifting continuously throughout the track section.
- 'Keep passing cars!' Pass as many cars as possible throughout the track section.
- 'Don't crash!' Avoid hitting any other cars, walls, or obstacles throughout the track section.
- 'Run through red/blue!' Drive on the indicated colour section of the roadway.



- 'Hit the blue cones!' There are twenty blue cones placed on the roadway—try to hit as many as you can.



- 'Cut the line!' Drive through the yellow heart lines between cars on the roadway. Lines cut once will not come back.



- 'Catch the Heart!' There are Hearts floating around on the roadway. Try your best to drive through the Hearts. Hearts collected once will not come back.



Special Requests

Satisfying certain conditions will open up Special Requests.

Ending

The game ending will change depending on your performance assessment.

4.3.4.3. Time Attack Mode



- 1) Sector Time
- 2) Position

This mode is a test of time in reaching the goal.

Player driving data is recorded for goal time, route best time, and slowest time. The player can then compete against his own time in subsequent plays.

When there is no player data recorded, a default data car will appear.

Ending

The game ending will change depending on your goal time.

Internet Ranking Password

If your time qualifies, you'll be given an Internet Ranking password. Using this password, you can participate in the Internet Ranking system.

Goal Choice

You can choose from five different destination goal points.
(This option is only available in the Time Attack Mode.)

Route Choice

After choosing a goal, you can decide on a specific route for that particular goal.

(This option is only available in the Time Attack Mode.)

There is one exception, however—Goal A, 'Tulip Garden', and Goal E, 'Cape Way' each have only one route so the Route Choice option will not be available.

Goal B, 'Metropolis', and Goal D, 'Imperial Avenue' each have four possible routes, while Goal C, 'Ancient Ruins' has six possible routes to choose from.

BGM Selection

There are seven different in-game songs to select from. In Versus Mode, each player can listen to his or her own individual selection.

- SPLASH WAVE (from original OutRun)
- MAGICAL SOUND SHOWER (from original OutRun)
- PASSING BREEZE (from original OutRun)
- Risky Ride (new)
- Shiny World (new)
- Night Flight (new, includes lyrics)
- Life was bore (new, includes lyrics)

4.4. Versus Play

4.4.1. Versus Mode Game Play

The car colours for versus mode are fixed for each player. 1P: Red, 2P: Yellow, 3P: White/Silver (depending on car model), 4P: Black

The position order on the starting grid is determined by the order of Versus Mode entry (decided by who presses the Start Button first).

The course is decided as the route taken by whoever first reaches a given course branch.

4.4.2. Special Versus Mode Commands

The 'No Handicap' and 'Player Only' modes are selectable with special commands entered at the game's selection screen.

4.4.2.1.No Handicap Mode

In the usual Versus Mode, the player in second place during a race can catch up easier with computer assistance, but this assistance isn't available in the No Handicap mode.

To activate No Handicap mode, all participants in the Versus Mode competition must press the Brake pedal together with the Shifter up. (Push the shifter up while holding down the Brake pedal.) An icon will be displayed on the right side of the selection screen when this mode is activated.

4.4.2.2.Player Only Mode

In Player Only mode, no cars besides the player-controlled cars will appear in the race.

To activate Player Only mode, all participants in the Versus Mode competition must press the Brake pedal together with the Shifter down. (Push the shifter down while holding down the Brake pedal.) An icon will be displayed on the right side of the selection screen when this mode is activated.



4.5. Gameplay Techniques and Secret Commands

4.5.1. How to Drift



After letting go of the Gas pedal, immediately press the Brake pedal. Then, quickly steer sharply into the turn and press the Gas pedal.

In the case of Manual transmission, shift down one gear just before the turn, then immediately steer sharply into the turn.

4.5.2. Mid-game Quit Command



You can quit in the middle of a game. This command is only possible in the Single Player mode.

To activate the mid-game quit command, stop the car and press the Brake pedal, View Change button, and Shifter up. (While holding down the Brake pedal, continue to hold down the View Change button, and finally press the Shifter up.)

After inputting the command, the player is prompted, 'Do you really want to quit this game? Yes/No'. Choosing 'Yes' will finish the game, and 'No' will return the player to the game.

There are three conditions under which this command cannot be executed:

- The player is near the starting grid.
- The remaining time is under 8 seconds.
- 'No' has already been chosen once.

4.6. Character Introductions

Three major characters appear in the game.

1. Driver

Name: Alberto

Personal Info: Although easy-going on the outside, he's a real go-getter.
He has a very distinguished driving sense. He's also quite rich.

2. OutRun Mode Lady

Name: Jennifer

Personal Info: She's a filthy rich 'princess', always selfishly seeking the next thrill. She's involved with Alberto, his Ferrari a present from her. She has a sharp eye for driving techniques.

3. Heart Attack Lady

Name: Clarissa

Personal Info: She's peppy and unmistakably sexy. A driving fan, with a weakness for thrill rides.
She's very demanding, but her sweet character makes her hard to dislike.

5. MAINTENANCE INSTRUCTIONS

5.1. Explanation of Test and Data Display

Use the switches on the VTS to enter the TEST MODE. This will allow you to carry out post installation and periodic checks and adjustments. The following section details the function of each of the tests:



- Be very careful about entering TEST MODE. If the machine you wish to test is linked to other machines, exiting test on your machine will cause a network check to be carried out. This will disable all other machines linked to it.

ITEM	DESCRIPTION / REFERENCE	INTERVAL
INSTALLATION OF THE MACHINE	When the machine is installed perform the following checks: Check to see that each setting is as per the standard settings input at the time of shipment. In the INPUT TEST mode, check each switch and VR. Section 5.3.1 In the OUTPUT TEST mode, check each of the lamps. Section 5.3.2 In the MEMORY TEST mode check all of the IC's on the IC BD. Section 5.2.1	Monthly
MEMORY	On the TEST MENU screen choosing the MEMORY TEST allows self test to be performed. In this test RAM & ROM are tested.	Monthly
PERIODIC CHECKS	Periodically perform the following MEMORY TEST. Section 5.2.1. Ascertain each setting: In the INPUT TEST mode, test the control devices. Section 5.3.1 In the OUTPUT TEST mode, check each of the lamps. Section 5.3.2	Monthly
CONTROL SYSTEM	In the INPUT TEST mode, check each switch and VR. Section 5.3.1 Adjust or replace each switch and VR. Section 3.9	Monthly
MONITOR	In the CRT TEST mode, check to ensure the monitor is adjusted correctly. Section 5.2.4 Clean screen (switch off machine and remove the plug)	Monthly Weekly
IC BOARD	MEMORY TEST In the SOUND TEST mode, check the sound related ROMs. 5.2.3	Monthly
DATA CHECK	Check such data as held in the bookkeeping screens, relating to number and length of plays. Section 5.3.5	Monthly
EXTERIOR MAINTENANCE	Clean surfaces Lubricate seat sliders	Monthly
COIN MECHANISM	Check switch operation (if fitted)	Monthly

5.1.1. VTS Assembly



- Do not touch places other than those specified. Touching places not specified could cause an electric shock or short circuit.



Opening the Coin Chute door will reveal the VTS Assembly shown above. The function of each switch is as follows. The controls on the left affect the 1P cockpit, those on the right the 2P

TEST BUTTON
(TEST SW)

Used to enter TEST mode. Also has function during TEST mode. Refer to the later section detailing TEST mode.

SERVICE BUTTON
(SERVICE SW)

Gives credits without registering on the coin counter. Also used during TEST mode.

DEMAG

Demagnetises (degausses) the CRT to remove colour unevenness.

VOLUME MAIN

Adjusts the volume of the left and right main speakers.

VOLUME WOOFER

Adjusts the volume of the woofer.

5.2. System Test Mode



- The contents of settings changed in the TEST mode are stored when the test mode is finished from EXIT in the menu mode. If the power is turned off before the TEST mode is finished, the contents of setting change become ineffective.
- Executing "BACKUP DATA CLEAR" in the SYSTEM TEST MODE does not clear the BOOKKEEPING data in the GAME TEST mode.
- Entering the TEST mode clears fractional number of coins less than one credit and BONUS ADDER data.
- Perform setting as per specified in this manual for operation. If setting not specified is performed for operation, proper function of this product may not be obtained.

In the SYSTEM TEST MODE, IC BD functioning can be checked, the monitor adjusted, and the coin setting performed.

Refer to NAOMI NETWORK SYSTEM SERVICE MANUAL for the details. Note that the setting of the following items need to be performed in accordance with the instruction given.

CABINET TYPE : 1 PLAYER(S)
 MONITOR TYPE : HORIZONTAL
 SERVICE TYPE : COMMON
 COIN CHUTE TYPE : COMMON
 NETWORK TYPE : NONE

The SEQUENCE SETTING items of COIN/CREDIT SETTING are as follows.

SEQUENCE SETTING

- SEQUENCE 1: Number of credits required for starting the game.
 SEQUENCE 2: Number of credits required for continuing the play.
 SEQUENCE 3: Number of credits required for dedicated CARD purchase.
 SEQUENCE 4 -8: NOT USED

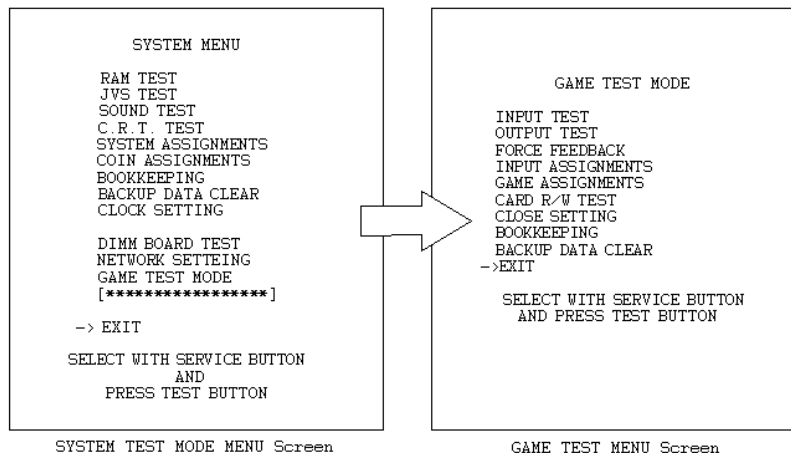

Press the TEST BUTTON to bring up the screen shown to the left.
 Press the SERVICE BUTTON to move downwards through the list. The arrow shows the current selection.
 Press the TEST BUTTON to activate the selected test.
 To finish TEST MODE, move the arrow to EXIT and press the TEST.

5.2.1. RAM Test

```

          RAM TEST

IC15 IC16 IC17S IC18S GOOD
IC22 IC23 IC24S IC25S GOOD
IC28 IC29S          GOOD
IC41          GOOD
IC42          GOOD
IC44 IC45S IC46 IC47S GOOD
IC91S IC92S        GOOD
IC98          GOOD

OPTIONAL SOUND BOARD:
IC2          GOOD

OPTIONAL COMMUNICATION BOARD:
IC7 IC8 IC9 IC10 GOOD

PRESS TEST BUTTON TO EXIT
    
```

The memory test mode is for automatically checking the on-board memory IC functioning. "GOOD" is displayed for normal IC's and "BAD " for abnormal IC's

- When the test is completed, if the results are as shown on the left then the Game Board is satisfactory.
- The test should take approximately thirty seconds to complete. If the test exceeds this time the board may have malfunctioned.
- After finishing the test press the TEST BUTTON or START BUTTON to exit.

5.2.2. JVS Test

```

          JVS TEST
          INPUT TEST
          > EXIT

NODE      1/1
NAME      SEGA ENTERPRISES, LTD. ;837-13741
          1/0 CONTROL BD2;Ver0.15;99/06
CMD VER   1.1
JVS VER   2.0
COM VER   1.0
SWITCH    2PLAYERS 12BITS
COIN      2SLOTS
ANALOG    8CH
DRIVER OUT 22CH

          SELECT WITH SERVICE BUTTON
          AND
          PRESS TEST BUTTON
    
```

- In this test, functioning of the I/O Board connected to the Game Board is displayed, and INPUT TEST can be performed. Select EXIT to return to the MENU screen, or select INPUT TEST to display the second screen.

```

          JVS TEST
          > DISPLAY CONFIG
          EXIT

NODE      1/1
SWITCH    _____
          SYSTEM _____
          PLAYER1 _____
          PLAYER2 _____
COIN      _____
          SLOT1 0000  SLOT2 8000
ANALOG    _____
          CH1 0000 CH2 0000 CH3 0000 CH4 0000
          CH5 0000 CH6 0000 CH7 0000 CH8 0000

          SELECT WITH SERVICE BUTTON
          AND
          PRESS TEST BUTTON
    
```

With a switch input from the control panel etc., this changes into 1.
 With a coin switch input, this accumulates. And, the coin meter counts.
 Analogue values are displayed between 0000 and FF00.

Select EXIT to return to the MENU screen.

5.2.3. Sound Test

Select the sound test to check the status of the amplifiers, soundboards, and speakers.

Press the SERVICE button or view change button to move the arrow to the desired test item.

Press TEST button to output the sound.

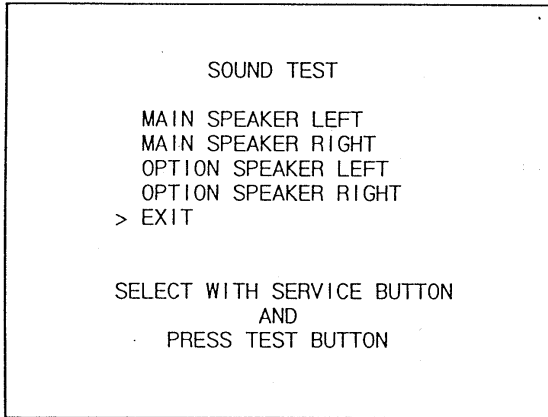

- Select the sound source with SERVICE.
- On pressing TEST, the test sound is emitted from the selected source.

Select EXIT to return to MENU screen.

5.2.4. C.R.T Test

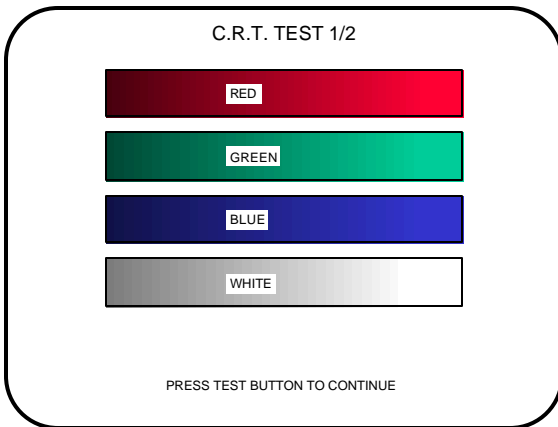

Selecting CRT test allows the projector adjustment to be checked for colour and distortion.

Press the test or start button to have the second CRT test screen appear.

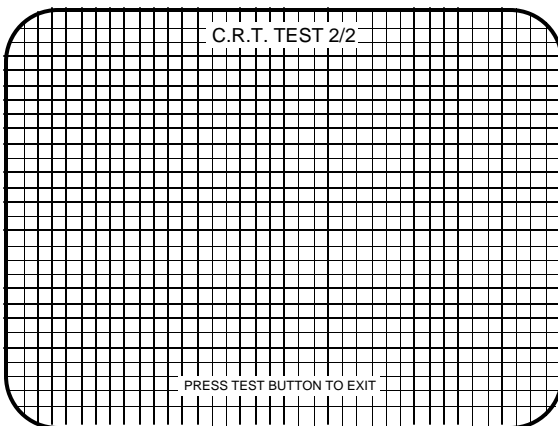

5.2.5. System Assignments

Allows system options to be set. Select required setting with SERVICE button, confirm with TEST button. Default settings are indicated in parentheses.

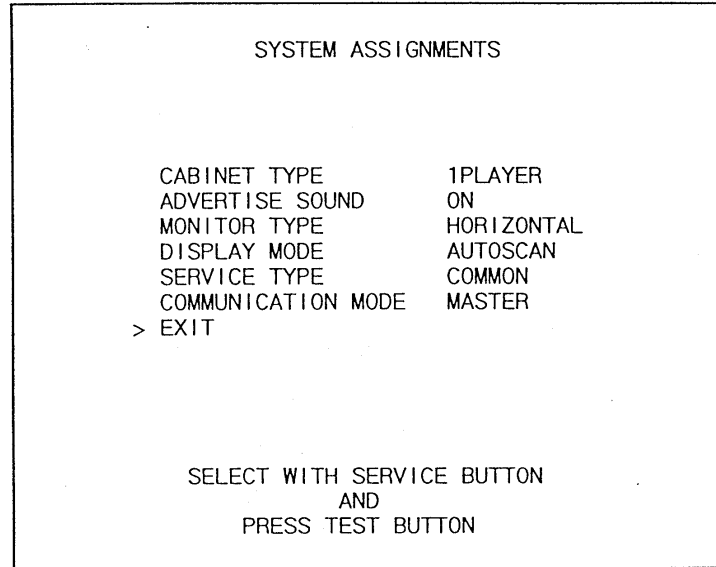

- CABINET TYPE specifies Control Panel and number of Coin Chutes. The number of players displayed in BOOKKEEPING varies in accordance with the value displayed here. (**1PLAYER**)
- ADVERTISE SOUND allows the sound emission to be turned (**ON**) or OFF during ADVERTISE MODE.
- MONITOR TYPE changes the orientation of the image on the screen (**HORIZONTAL**)
- SERVICE TYPE sets the functioning of the SERVICE button, should several SERVICE buttons exist. **INDIVIDUAL**: Service credit is applied to the machine on which the SERVICE button is pressed. **(COMMON)**: Service credit is applied to all machines when SERVICE button is pressed.

5.2.5.1. Coin Assignments



Select the coin assignments mode to set the coin to credit ratios.

This can be any of the pre-set values or can be done manually.

5.2.5.2.Coin/Credit Setting (Coin Chute Common Type)

SETTING	FUNCTIONING OF COIN CHUTE #1		FUNCTIONING OF COIN CHUTE #2	
SETTING #1	1 COIN	1 CREDIT	1 COIN	1 CREDIT
SETTING #2	1 COIN	2 CREDITS	1 COIN	1 CREDIT
SETTING #3	1 COIN	3 CREDIT	1 COIN	1 CREDIT
SETTING #4	1 COIN	4 CREDITS	1 COIN	1 CREDIT
SETTING #5	1 COIN	5 CREDITS	1 COIN	1 CREDIT
SETTING #6	1 COIN	2 CREDITS	1 COIN	2 CREDITS
SETTING #7	1 COIN	5 CREDITS	1 COIN	2 CREDITS
SETTING #8	1 COIN	3 CREDITS	1 COIN	3 CREDITS
SETTING #9	1 COIN	4 CREDITS	1 COIN	4 CREDITS
SETTING #10	1 COIN	5 CREDITS	1 COIN	5 CREDITS
SETTING #11	1 COIN	6 CREDITS	1 COIN	6 CREDITS
SETTING #12	2 COINS	1 CREDIT	2 COINS	1 CREDIT
SETTING #13	1 COIN	1 CREDIT	2 COINS	1 CREDIT
SETTING #14	1 COIN	2 CREDITS	2 COINS	1 CREDIT
SETTING #15	1 COIN 2 COINS	1 CREDIT 3 CREDITS	1 COIN 2 COINS	1 CREDIT 3 CREDITS
SETTING #16	1 COIN	3 CREDITS	1 COIN 2 COINS	1 CREDIT 3 CREDITS
SETTING #17	3 COINS	1 CREDIT	3 COINS	1 CREDIT
SETTING #18	4 COINS	1 CREDIT	4 COINS	1 CREDIT
SETTING #19	1 COIN 2 COINS 3 COINS 4 COINS	1 CREDIT 2 CREDITS 3 CREDITS 5 CREDITS	1 COIN 2 COINS 3 COINS 4 COINS	1 CREDIT 2 CREDITS 3 CREDITS 5 CREDITS
SETTING #20	1 COIN	5 CREDITS	1 COIN 2 COINS 3 COINS 4 COINS	1 CREDIT 2 CREDITS 3 CREDITS 5 CREDITS
SETTING #21	5 COINS	1 CREDIT	5 COINS	1 CREDIT
SETTING #22	1 COIN	2 CREDITS	3 COINS 5 COINS	1 CREDIT 2 CREDITS
SETTING #23	2 COINS 4 COINS 5 COINS	1 CREDIT 2 CREDITS 3 CREDITS	2 COINS 4 COINS 5 COINS	1 CREDIT 2 CREDITS 3 CREDITS
SETTING #24	1 COIN	3 CREDITS	2 COINS 4 COINS 5 COINS	1 CREDIT 2 CREDITS 3 CREDITS
SETTING #25	1 COIN 2 COINS 3 COINS 4 COINS 5 COINS	1 CREDIT 2 CREDITS 3 CREDITS 4 CREDITS 6 CREDITS	1 COIN 2 COINS 3 COINS 4 COINS 5 COINS	1 CREDIT 2 CREDITS 3 CREDITS 4 CREDITS 6 CREDITS
SETTING #26	1 COIN	6 CREDITS	1 COIN 2 COINS 3 COINS 4 COINS 5 COINS	1 CREDIT 2 CREDITS 3 CREDITS 4 CREDITS 6 CREDITS
SETTING #27	FREE PLAY		FREE PLAY	

5.2.5.3.Coin/Credit Setting (Coin Chute Individual Type)

SETTING	FUNCTIONING OF COIN CHUTE #1	
SETTING #1	1 COIN	1 CREDIT
SETTING #6	1 COIN	2 CREDITS
SETTING #8	1 COIN	3 CREDITS
SETTING #9	1 COIN	4 CREDITS
SETTING #10	1 COIN	5 CREDITS
SETTING #11	1 COIN	6 CREDITS
SETTING #12	2 COINS	1 CREDIT
SETTING #15	1 COIN	1 CREDIT
	2 COINS	3 CREDITS
SETTING #17	3 COINS	1 CREDIT
SETTING #18	4 COINS	1 CREDIT
SETTING #19	1 COIN	1 CREDIT
	2 COINS	2 CREDITS
	3 COINS	3 CREDITS
	4 COINS	5 CREDITS
SETTING #21	5 COINS	1 CREDIT
SETTING #22	3 COINS	1 CREDITS
	5 COINS	2 CREDITS
SETTING #23	2 COINS	1 CREDIT
	4 COINS	2 CREDITS
	5 COINS	3 CREDITS
SETTING #25	1 COIN	1 CREDIT
	2 COINS	2 CREDITS
	3 COINS	3 CREDITS
	4 COINS	4 CREDITS
	5 COINS	6 CREDITS
SETTING #27	FREE PLAY	

5.2.5.4.Manual Setting

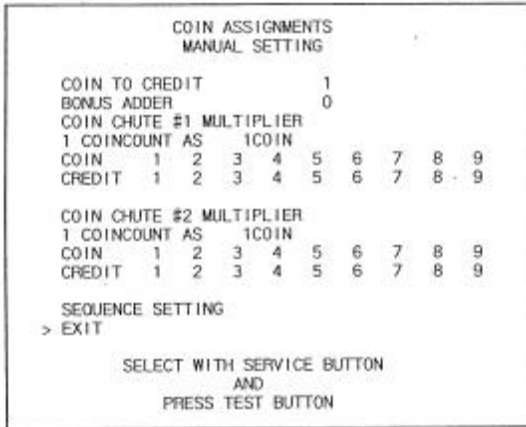

Select manual setting to manually set the coin to credit ratios.

The available combinations are detailed below.

MANUAL SETTING

COIN TO CREDIT	1 COIN	1 CREDIT
	2 COINS	1 CREDIT
	3 COINS	1 CREDIT
	4 COINS	1 CREDIT
	5 COINS	1 CREDIT
	6 COINS	1 CREDIT
	7 COINS	1 CREDIT
	8 COINS	1 CREDIT
	9 COINS	1 CREDIT

BONUS ADDER	NO BONUS ADDER
	2 COINS GIVE 1 EXTRA COIN
	3 COINS GIVE 1 EXTRA COIN
	4 COINS GIVE 1 EXTRA COIN
	5 COINS GIVE 1 EXTRA COIN
	6 COINS GIVE 1 EXTRA COIN
	7 COINS GIVE 1 EXTRA COIN
	8 COINS GIVE 1 EXTRA COIN
	9 COINS GIVE 1 EXTRA COIN

COIN CHUTE MULTIPLIER	1 COIN COUNTS AS 1 COIN
	1 COIN COUNTS AS 2 COINS
	1 COIN COUNTS AS 3 COINS
	1 COIN COUNTS AS 4 COINS
	1 COIN COUNTS AS 5 COINS
	1 COIN COUNTS AS 6 COINS
	1 COIN COUNTS AS 7 COINS
	1 COIN COUNTS AS 8 COINS
	1 COIN COUNTS AS 9 COINS

5.2.5.5.Sequence Setting

Selecting SEQUENCE SETTING allows the number of credits required to start the game to be set. Each sequence can be set between 1 and 5. Select EXIT to return to the first screen.



5.2.5.6. Bookkeeping

```

BOOKKEEPING PAGE#1

TOTAL TIME      55H27M13S
COIN1          16 SERVICE1      5
COIN2           4 SERVICE2      0
CREDIT         10

TOTAL COIN      20
COIN CREDIT    10
SERVICE CREDIT 5
TOTAL CREDIT   15

PRESS SERVICE BUTTON TO ANOTHER PAGE
PRESS TEST BUTTON TO EXIT
    
```

```

BOOKKEEPING PAGE#2

PLAYER1
SE01      1
SE02      0
SE03      1
SE04      0
SE05      0
SE06      0
SE07      0
SE08      0

PRESS SERVICE BUTTON TO ANOTHER PAGE
PRESS TEST BUTTON TO EXIT
    
```

This mode consists of 2 pages that allow the data relating to credit and game play time to be checked.

In page 1 mode press SERVICE to proceed to page 2, in page 2 mode press TEST to return to the test menu.

- Total time is displayed as XXH XXM XXS and no date will be displayed after exceeding 24 hours.
- The displays for number of coin and number of service vary depending on the CABINET TYPE set in SYSTEM ASSIGNMENTS. Number of credit displays 1 if COIN CHUTE TYPE is set to COMMON in COIN ASSIGNMENTS. If COIN CHUTE TYPE is set to INDIVIDUAL, the applicable number in CABINET TYPE setting will be displayed.
- On the second screen, each sequence displays the frequency of functioning.

5.2.5.7. Backup Data Clear

```

BACKUP DATA CLEAR

YES (CLEAR)
> NO (CANCEL)

SELECT WITH SERVICE BUTTON
AND
PRESS TEST BUTTON
    
```

Clears the contents of bookkeeping. When clearing, bring the arrow to "YES (CLEAR)" and press the test button. When the data has been cleared "COMPLETED" will be displayed. Bring the arrow to "NO (CANCEL)" and press the test button to return to the menu mode.

Note that this does not clear the contents of BOOKKEEPING in GAME TEST MODE. For this, use the BACKUP DATA CLEAR in GAME TEST MODE.

5.2.5.8.ROM BD Test

In this test, Game Board ROM is checked. If GOOD is displayed, it is satisfactory. The IC number, TYPE, BYTE and WORD refer to the checksum of each unit. Press TEST to exit.

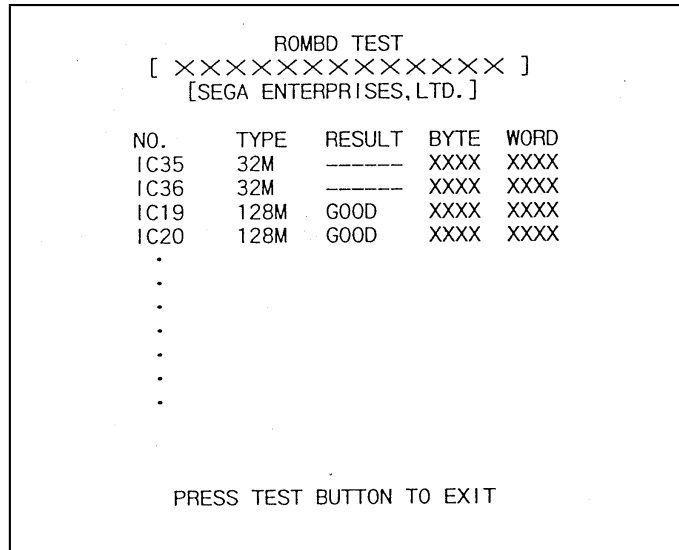

On above screen, IC35 and IC36 (program ROMs) do not display GOOD or BAD. Press TEST Button to EXIT.

5.2.5.9. Clock Setting

YEAR, MONTH, DAY, HOUR and MINUTE are set for SEGA NAOMI BOARD. Select the desired item with SERVICE button and press TEST to increase the value. Select EXIT to return to MENU mode.

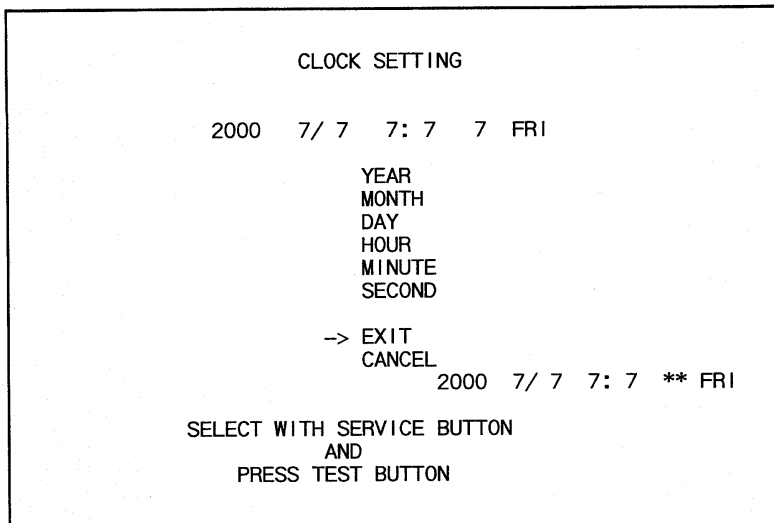

5.3. Game Test Mode

[IMPORTANT]

When changing the game configuration, changes will not be enabled until the Game Test Mode has been completed. Be sure to exit the Game Test Mode properly after configuration changes.

Select GAME TEST MODE from the System Menu screen to display the Game Test Menu screen as follows. Use the SERVICE Button to move the cursor to the desired test item. Press the TEST Button to enter the selected item.

NOTE: In Upright cabinet types, the DRIVE BOARD TEST is not necessary and the option will not be displayed.

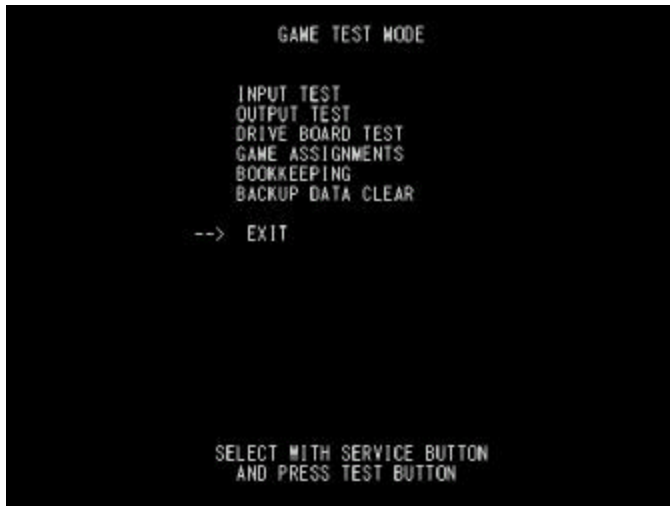

After selecting an item, read the explanations below regarding operation.

After the test is complete, move the cursor to EXIT and press the TEST Button to return to the System Menu screen.

5.3.1. Input Test

Select INPUT TEST to display the following screen and check the status of input devices. This test should be used periodically to check that each input device is functioning correctly.

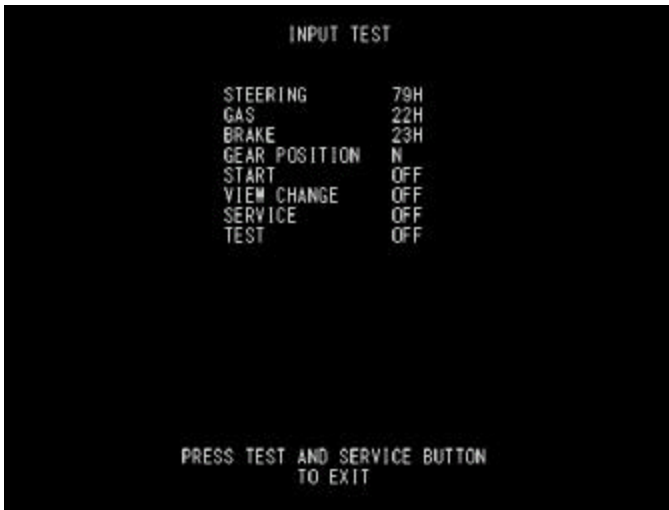

Test the STEERING, GAS (ACCEL) and BRAKE controls to ensure that they are functioning properly and that the parameters change smoothly as each input device is operated.

Display N, UP and DOWN using the GEAR POSITION. N displays that there is no control input. Verify that both UP and DOWN display in sync with the position of the shift knob.

Press the START, CHANGE VIEW, SERVICE and TEST Buttons. If functioning correctly, each indicator will switch from OFF to ON.

Press the SERVICE and TEST Buttons simultaneously to return to the Game Test Menu screen.

5.3.2. Output Test

Select OUTPUT TEST to display the following screen and check the status of each lamp. This test should be used periodically to check that the lamps are functioning correctly.

On this screen the cursor will switch automatically between items, lighting up the respective lamps.



- START BUTTON : Lights up the START button.
- VIEW CHANGE BUTTON: Lights up the View Change button.

Press the TEST Button to return to the Game Test Menu screen.

5.3.3. Drive Board Test

Select DRIVE BOARD TEST to display the following screen and check the status of steering motor.

Use the SERVICE Button to select the desired test item. Press the TEST Button to activate the selected item.

NOTE: This test will not be displayed in Upright cabinet types.



- STOP MOTOR: Halts motor activity.
- ROLL RIGHT: Rotates steering wheel completely to the right.
- ROLL LEFT: Rotates steering wheel completely to the left.
- CENTER OF STEER: Steering wheel motor's center of control is displayed.
 - RIGHT: Moves center of control position to the right.
 - LEFT: Moves center of control position to the left.
- MOTOR POWER: Sets the steering resistance. There are four levels to choose from, 100% (strong resistance), 90%, 80%, and 60% (weak resistance). (80% is the default setting)

After changing the settings, select EXIT and press the TEST Button to return to the Game Test Menu screen.

5.3.4. Game Assignments

Select GAME ASSIGNMENTS to display the current game settings and make changes.

Changes to settings are not enabled until Test Mode is exited. After changing settings, be sure to exit Test Mode.

NOTE: When adjusting network play settings, DIFFICULTY, ADVERTISE SOUND, LANGUAGE, SPEEDOMETER, and QUICK START items will be decided by the cabinet with LINK_ID "1". Changes made to the game display or settings during game play do not affect the Game Test Menu settings.

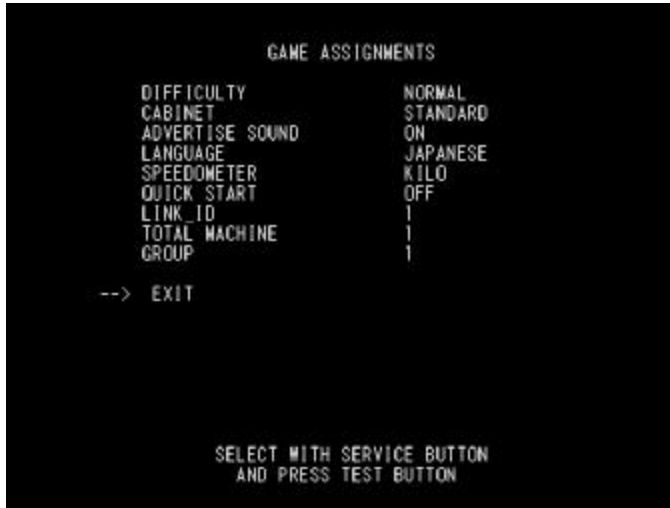

Perform the following settings for each item.

? DIFFICULTY: The game difficulty setting. There are 5 difficulty levels with VERY EASY being the easiest setting and VERY HARD being the most difficult setting. (Default Setting: NORMAL)

? CABINET TYPE: The game cabinet type setting. Choose from either STANDARD or UPRIGHT.

? ADVERTISE SOUND: The setting to turn the advertising sound ON/OFF. (Default Setting: ON)

? LANGUAGE: The game language setting. Choose from either JAPANESE or ENGLISH. (With JAPAN as the Country Setting, the default LANGUAGE setting is JAPANESE. ENGLISH is set as the default for a Country Setting of USA or EXPORT.)

? SPEEDOMETER: The speed display setting. During game play, KILO will be displayed as "km/h", and MILE as "mph". Choose one of these options. (With JAPAN or EXPORT as the Country Setting, the default SPEEDOMETER setting is KILO (km/h). MILE (mph) is set as the default for a Country Setting of USA.)

? QUICK START: Choose OFF or ON. The ON setting takes the player directly to the game selection screen after entering credits into the machine. (Default Setting: OFF)

? LINK_ID: The setting which determines the Player Number of each cabinet. It assigns unique numbers for cabinets in a single group. Do not assign two or more cabinets the same number. For network play, it is necessary to complete the LINK_ID, TOTAL MACHINE, and GROUP settings for each cabinet. (Default Setting: 1, Maximum: 4)

? TOTAL MACHINE : The number of network connected game cabinets. (Sets the number of competing cabinets in Versus Mode.) Setting this to "1" limits possible play modes to Single Player mode only. (Default Setting: 1, Maximum: 4)

? GROUP: Used for dividing networked cabinets into groups. For example, to split up a group of four networked machines into two groups of two cabinets, set two cabinets to "1" and the other two cabinets to "2". Generally, setting all cabinets to "1" is recommended.

After changing the settings, select EXIT and press the TEST Button to return to the Game Test Menu screen.

<Network Versus Mode Cabinet Settings>

Cases for four cabinets (A, B, C, and D) connected via network cable.

4-Cabinet Versus

CABINET	A	B	C	D
LINK_ID	1	2	3	4
TOTAL MACHINE	4	4	4	4
GROUP	1	1	1	1
Status	Four cabinets can compete.			

3-Cabinet Versus

CABINET	A	B	C	D
LINK_ID	1	1	2	3
TOTAL MACHINE	1	3	3	3
GROUP	1	2	2	2
Status	Single play only.	Three cabinets can compete.		

2-Cabinet Versus

CABINET	A	B	C	D
LINK_ID	1	2	1	2
TOTAL MACHINE	2	2	2	2
GROUP	1	1	2	2
Status	Two cabinets can compete.		Two cabinets can compete.	

5.3.5. Bookkeeping

Selecting BOOKKEEPING will display the following screen. All up-to-date operation data will be displayed on two BOOKKEEPING screens.

Use the TEST Button to cycle between the first screen (BOOKKEEPING 1/2) and the second screen (BOOKKEEPING 2/2).

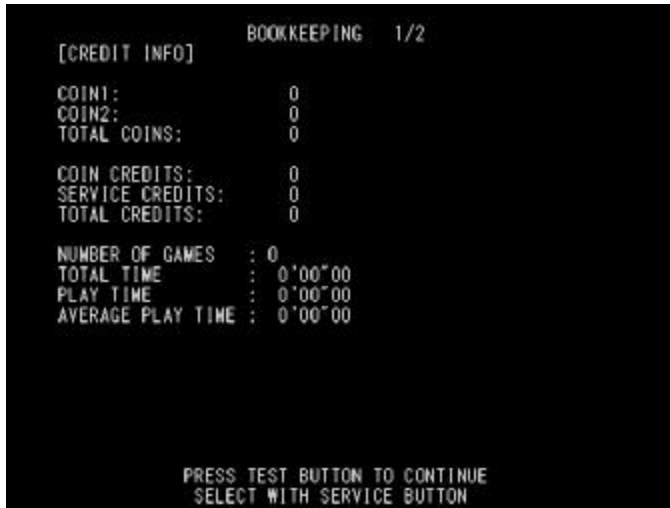

- | | |
|----------------------|--|
| ? COIN CHUTE #1: | The number of coins inserted into Coin Slot 1. |
| ? COIN CHUTE #2: | The number of coins inserted into Coin Slot 2. |
| ? TOTAL COINS: | The total number of coins inserted into the coin slots. |
| ? COIN CREDITS: | The number of credits for the coins inserted. |
| ? SERVICE CREDITS: | The number of credits input by the SERVICE Button. |
| ? TOTAL CREDITS: | Total credits from coins and the SERVICE Button. |
| ? NUMBER OF GAMES: | The total number of games played. |
| ? TOTAL TIME: | The amount of time the unit has been in operation. |
| ? PLAY TIME: | Total playing time. |
| ? AVERAGE PLAY TIME: | Total play time divided by the total number of games played. |

Press the TEST Button to move to screen 2/2 of BOOKKEEPING.

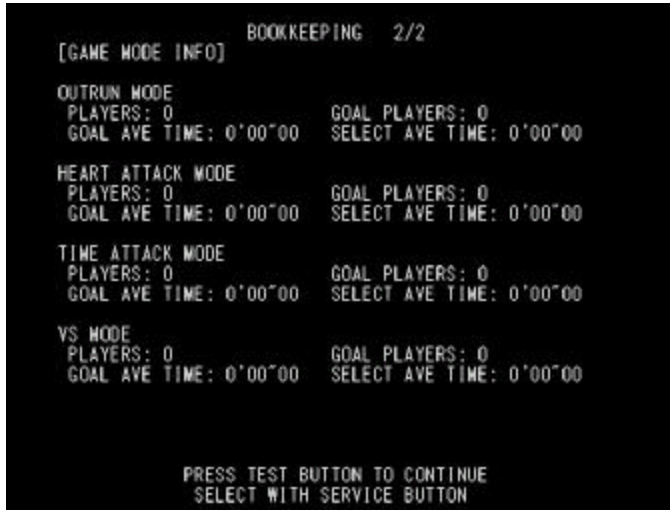

This shows the number of plays and the respective play times. This histogram should be referred to when setting the Game Difficulty.

Press the TEST Button to return to the Game Test Menu screen.

5.3.6. Backup Data Clear

Select BACKUP DATA CLEAR to clear the contents of BOOKKEEPING, ranking data and coin/credit data.

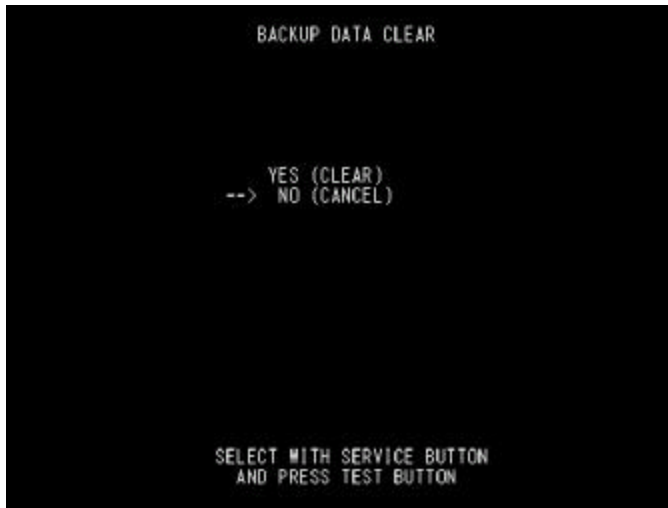

To clear data, use the SERVICE Button to move the cursor to YES (CLEAR) and then press the TEST Button. When the data has been cleared, the message "COMPLETED" will be displayed.

Press the TEST Button again to return to the Game Test Menu screen.

Move the cursor to NO (CANCEL) and press the TEST Button to return to the Game Test Menu screen without clearing the data.

Note that this operation does not affect GAME ASSIGNMENTS or GUN ADJUSTMENT settings.

6. COIN MECH INSTALLATION AND CREDIT BOARD SET UP

6.1. Introduction

Game credits between the Coin Mechanism and the game board for this machine are controlled by a VTS board. This electronic circuit allows the price of play to be set for a range of different countries. These functions are set on Dual In Line (DIL) PCB mounted switches.

SW1 is used to set the currency (or coin ratio) and SW3 the price of play. Refer to the Tables on the following pages for the correct settings for your environment.

The VTS board pictured below is mounted in the Coin Chute Tower.

The VTS board is connected to the coin validator and lamps via a dedicated wiring harness depending upon the coin validator used:

Wiring Harness	Validator
LM1006	Coin Controls (15 way connector)
LM1007	Mars (13 way connector)
LM1008	Mechanical See note 2
N/A	NRI See note 1

Notes

1. If NRI mechanisms are to be used, these should be ordered with the highest denomination coin on coin path #1 and the lowest denomination on coin path #4. The VTS board should be then be set up for either the UK or Switzerland settings. A minimum connecting lead length of 600mm is required.
2. Mechanical coin mechanisms may be connected in parallel allowing two identical mechanisms to be fitted.

The VTS Board

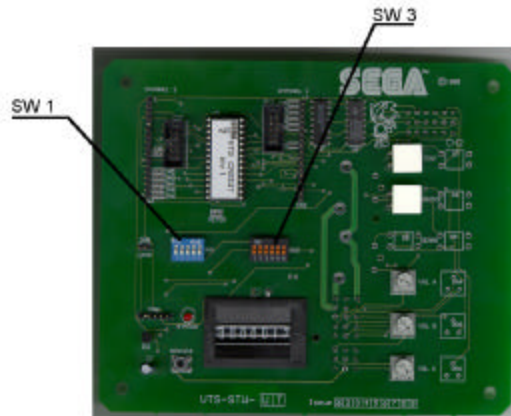

Credit Board Mode Settings Switch 3																				
Country	Setting	Switch 3 Setting						Coin Validator Programming								C120/SR3 Only				
		SW1	SW2	SW3	SW4	SW5	SW6	COIN1	COIN2	COIN3	COIN4	COIN5	COIN6	COIN7	COIN8	COIN9	COIN10	COIN11	COIN12	
UK	Coin Controls C220 Parallel	OFF	OFF	OFF	OFF			£1	50p new	20p	10p	-	50p old	-	-					
UK	Coin Controls C220 Binary	ON	OFF	OFF	OFF			£1	50p new	20p	10p	-	50p old	-	£2					
UK	Coin Controls C220 Binary	OFF	ON	OFF	OFF			£1	50p new	20p	10p	-	£2	-	50p old					
UK	Coin Controls SR3 Parallel	ON	ON	OFF	OFF			£1	50p new	20p	10p	-	£2	-	50p old	-	-	-	-	
UK Euro	Coin Controls SR3 Parallel	OFF	OFF	ON	OFF			£2 €2	£1 €1	50p new 50¢	20p 20¢	10p 10¢	-	-	-	50p old	-	-	-	
UK	Mars ME/MS 111 Parallel	ON	OFF	ON	OFF			£1	£2	20p	10p	50p new	50p old							
UK	NRI Parallel	OFF	ON	ON	OFF			10p	20p	50p	£1	£2	-							
Belgium	Parallel	ON	ON	ON	OFF			-	50BFr	20BFr	5BFr									
Holland	Parallel	OFF	OFF	OFF	ON			-	5NLG	2.5NLG	1NLG									
Austria	SR3 Parallel	ON	OFF	OFF	ON			20Sch	10Sch	5Sch	1Sch									
Spain	Coin Controls C220 Binary	OFF	ON	OFF	ON			500Pta	200Pta	100Pta	50Pta	25Pta	200Pt old	50Pta old	25Pta old					
Spain	SR3/NRI Parallel	ON	ON	OFF	ON			500Pta	200Pta	100Pta	50Pta	25Pta	-	-	200Pta	-	50Pta old	25Pta old	-	
Spain	Coin Controls C220 Parallel	OFF	OFF	ON	ON			100Pta	50Pta new	-	25Pta new	-	50Pta old	-	25Pta old					
Portugal Euro	Parallel	ON	OFF	ON	ON			200Es €1	100Es 50¢	50Es	-	-	-	-	-					
	TBA					OFF		TBA					Please Note The credit board automatically sets the validator for parallel and binary operation through an output on pin 8 of the 17 way pinstrip. For the feature to work it is necessary for the validator interconnecting cable to include at wire at this position							
						ON		TBA												
	Channels						OFF	Direct Mode												
							ON	2 channel Mode												

Note: These switch settings are under constant review and may change due to world currency updates.

- Set SW 1 according to the option settings found in the relevant Price of Play Settings Table on the following pages.
- For Germany (DM), France (Fr) & Switzerland (SFr), use the appropriate existing setting shown above (from another country) that matches the coin ratios programmed into your coin mec

- Set SW 3 on the VTS/Excel board as shown in the table above corresponding to the country required.

6.1.1. Price of Play Settings UK

	Price	Bonus			DIL Switch 1				
					Switch 1	Switch 2	Switch 3	Switch 4	Switch 5
1	10p	No Bonus			OFF	OFF	OFF	OFF	OFF
2	10p	6 = 50p			ON	OFF	OFF	OFF	OFF
3	20p	No Bonus			OFF	ON	OFF	OFF	OFF
4	20p	3 = 50p	6 = £1	12 = £2	ON	ON	OFF	OFF	OFF
5	30p	No Bonus			OFF	OFF	ON	OFF	OFF
6	30p	1.66 = 50p	4 = £1	8 = £2	ON	OFF	ON	OFF	OFF
7	30p	2 = 50p	4 = £1		OFF	ON	ON	OFF	OFF
8	30p	AML *	3 = £1	6 = £2	ON	ON	ON	OFF	OFF
9	40p	No Bonus			OFF	OFF	OFF	ON	OFF
10	40p	1.25 = 50p	3 = £1	6 = £2	ON	OFF	OFF	ON	OFF
11	50p	No Bonus			OFF	ON	OFF	ON	OFF
12	50p		3 = £1	6 = £2	ON	ON	OFF	ON	OFF
13	50p		2 = £1	5 = £2	OFF	OFF	ON	ON	OFF
14	60p	No Bonus			ON	OFF	ON	ON	OFF
15	60p		2 = £1	4 = £2	OFF	ON	ON	ON	OFF
16	80p	No Bonus			ON	ON	ON	ON	OFF
17	80p	1.25 = £1	2 = £1.50	2.5 = £2	OFF	OFF	OFF	OFF	ON
18	£1	No Bonus			ON	OFF	OFF	OFF	ON
19	£1		3 = £2		OFF	ON	OFF	OFF	ON
20	£1		2 = £2	5 = £4	ON	ON	OFF	OFF	ON
21	£1.50	No Bonus			OFF	OFF	ON	OFF	ON
22	£1.50		2 = £2		ON	OFF	ON	OFF	ON
23	£2	No Bonus			OFF	ON	ON	OFF	ON
24	£2			3 = £5	ON	ON	ON	OFF	ON
25	£3	No Bonus			OFF	OFF	OFF	ON	ON
26	£3			2 = £5	ON	OFF	OFF	ON	ON
27	£5	No Bonus			OFF	ON	OFF	ON	ON
28	£5			3 = £10	ON	ON	OFF	ON	ON
29	£7.50	No Bonus			OFF	OFF	ON	ON	ON
30	£7.50			2 = £10	ON	OFF	ON	ON	ON
31	£10	No Bonus			OFF	ON	ON	ON	ON
32	Free Play				ON	ON	ON	ON	ON

6.1.2. Price Of Play Settings Euro

	Price	Bonus			DIL Switch 1				
					Switch 1	Switch 2	Switch 3	Switch 4	Switch 5
1	10¢	No Bonus			OFF	OFF	OFF	OFF	OFF
2	10¢	6 = 50¢			ON	OFF	OFF	OFF	OFF
3	20¢	No Bonus			OFF	ON	OFF	OFF	OFF
4	20¢	3 = 50¢	6 = €1	12 = €2	ON	ON	OFF	OFF	OFF
5	30¢	No Bonus			OFF	OFF	ON	OFF	OFF
6	30¢	1.66 = 50¢	4 = €1	8 = €2	ON	OFF	ON	OFF	OFF
7	30¢	2 = 50¢	4 = €1		OFF	ON	ON	OFF	OFF
8	30¢	AMLD *	3 = €1	6 = €2	ON	ON	ON	OFF	OFF
9	40¢	No Bonus			OFF	OFF	OFF	ON	OFF
10	40¢	1.25 = 50¢	3 = €1	6 = €2	ON	OFF	OFF	ON	OFF
11	50¢	No Bonus			OFF	ON	OFF	ON	OFF
12	50¢		3 = €1	6 = €2	ON	ON	OFF	ON	OFF
13	50¢		2 = €1	5 = €2	OFF	OFF	ON	ON	OFF
14	60¢	No Bonus			ON	OFF	ON	ON	OFF
15	60¢		2 = €1	4 = €2	OFF	ON	ON	ON	OFF
16	80¢	No Bonus			ON	ON	ON	ON	OFF
17	80¢	1.25 = £1	2 = €1.50	2.5 = €2	OFF	OFF	OFF	OFF	ON
18	€1	No Bonus			ON	OFF	OFF	OFF	ON
19	€1		3 = €2		OFF	ON	OFF	OFF	ON
20	€1		2 = €2	5 = €4	ON	ON	OFF	OFF	ON
21	€1.50	No Bonus			OFF	OFF	ON	OFF	ON
22	€1.50		2 = €2		ON	OFF	ON	OFF	ON
23	€2	No Bonus			OFF	ON	ON	OFF	ON
24	€2			3 = €5	ON	ON	ON	OFF	ON
25	€3	No Bonus			OFF	OFF	OFF	ON	ON
26	€3			2 = €5	ON	OFF	OFF	ON	ON
27	€5	No Bonus			OFF	ON	OFF	ON	ON
28	€5			3 = €10	ON	ON	OFF	ON	ON
29	€7.50	No Bonus			OFF	OFF	ON	ON	ON
30	€7.50			2 = €10	ON	OFF	ON	ON	ON
31	€10	No Bonus			OFF	ON	ON	ON	ON
32	Free Play				ON	ON	ON	ON	ON

6.1.3. Price Of Play Settings Austria-Czech-Denmark-Norway-Israel-France2

	Price	Bonus			Switch 1				
					Switch 1	Switch 2	Switch 3	Switch 4	Switch 5
1	1	No Bonus			OFF	OFF	OFF	OFF	OFF
2	1			11 = 10	ON	OFF	OFF	OFF	OFF
3	1		6 = 5		OFF	ON	OFF	OFF	OFF
4	2	No Bonus			ON	ON	OFF	OFF	OFF
5	2			6 = 10	OFF	OFF	ON	OFF	OFF
6	2		3 = 5		ON	OFF	ON	OFF	OFF
7	3	No Bonus			OFF	ON	ON	OFF	OFF
8	3			4 = 10	ON	ON	ON	OFF	OFF
9	3		2 = 5		OFF	OFF	OFF	ON	OFF
10	4	No Bonus			ON	OFF	OFF	ON	OFF
11	4		3 = 10		OFF	ON	OFF	ON	OFF
12	5	No Bonus			ON	ON	OFF	ON	OFF
13	5			3 = 10	OFF	OFF	ON	ON	OFF
14	6	No Bonus			ON	OFF	ON	ON	OFF
15	6			4 = 20	OFF	ON	ON	ON	OFF
16	8	No Bonus			ON	ON	ON	ON	OFF
17	10	No Bonus			OFF	OFF	OFF	OFF	ON
18	10			3 = 20	ON	OFF	OFF	OFF	ON
19	20	No Bonus			OFF	ON	OFF	OFF	ON
20	20			3 = 50	ON	ON	OFF	OFF	ON
21	30	No Bonus			OFF	OFF	ON	OFF	ON
22	30			2 = 50	ON	OFF	ON	OFF	ON
23	50	No Bonus			OFF	ON	ON	OFF	ON
24	50			3 = 100	ON	ON	ON	OFF	ON
32	Free Play				ON	ON	ON	ON	ON

7. DESIGN RELATED PARTS



ITEM	PART NO,	DESCRIPTION
1	ORT-1603-BUK	STICKER SEAT BACK
2	ORT-1502UK	STICKER BASE L
3	ORT-1503UK	STICKER BASE R
4	ORT-1504UK	STICKER BASE LID
5	ORT-0215UK	BILLBOARD PLATE ORT TWIN
6	422-0922UK	PLAY INSTR SH ORT TWIN MULTI
7	422-0923UK	SUB INSTR SH ORT TWIN MULTI
8	ORT-1551-AUK	STICKER COVER PANEL L
9	ORT-1556-AUK	STICKER COVER PANEL R
10	ORT-1551-BUK	STICKER LINE L
11	ORT-1556-BUK	STICKER LINE R

8. PARTS LIST

8.1. Assembly Structure

ORT-00001UK TOP ASSY OTRUN 2 TWIN	
ORT-10001UK (x2) ASSY COCKPIT 1P	
DUT-1120UK ASSY SUB MAIN BASE	
ORT-1550UK ASSY MONITOR COVER L 2P	
APC-1560 ASSY SPEAKER L	
ORT-1550UK ASSY MONITOR COVER R 2P	
APC-1565 ASSY SPEAKER R	
ORT-2000UK ASSY CONTROL PANEL	
SPG-2500 ASSY HANDLE MECHA	
ORT-2100 ASSY SW PLATE	
ORT-1100UK ASSY PEDAL BASE ORT	
SPG-2200 ASSY BRAKE & ACCELL	
ORT-1600UK ASSY SEAT TWIN 1P	
ORT-4500UK ASSY MAIN BD	
ORT-4600UK ASSY ELEC BD	
FRI 1510UK ASSY BASE LID R	
ORT-INST-TW ASSY INSTALLATION KIT ORT TWIN	
ORT-0200UK ASSY BILLBOARD	
FRI-0300UK ASSY COINCHUTE TOWER FRI	
ORT-0500UK ASSY WIRE COVER ORT TWIN	
ORT-0400UK ASSY AC BRKT MAIN	
ORT-0700UK ASSY AC BRKT SUB	
ORT-4560UK ASSY LAN COM2	

8.2. **ORT-00001UK TOP ASSY OTRUN2 TWIN**

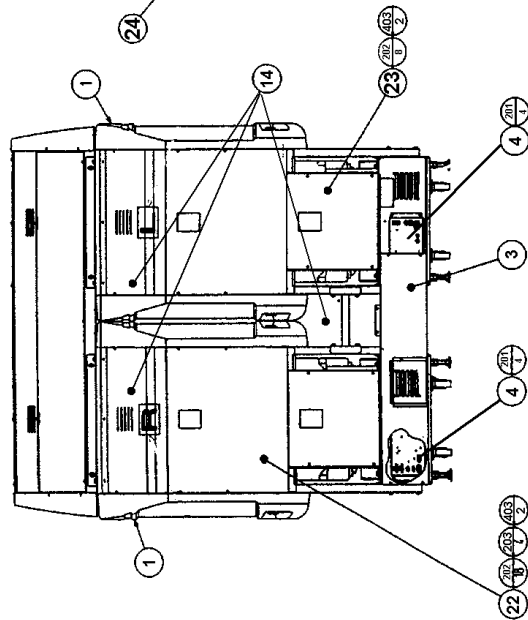
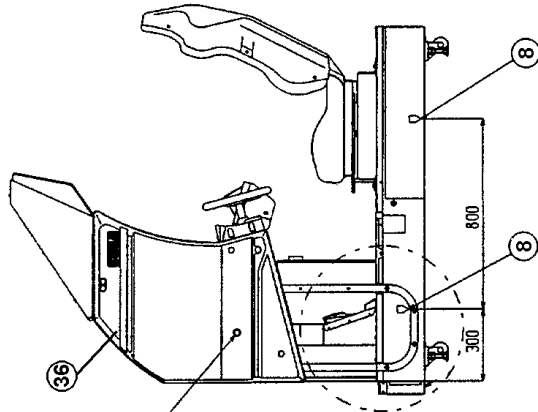
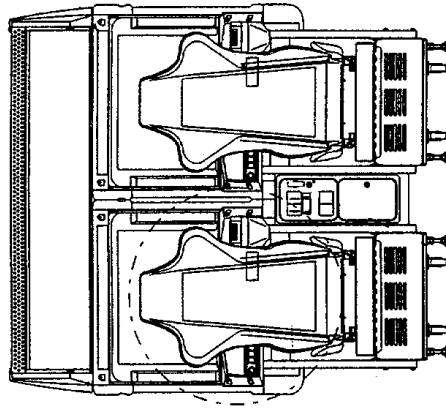

ITEM	PART NO.	QTY	DESCRIPTION	COMPONENT REF.
1	ORT-10001UK	2	ASSY COCKPIT 1P	
3	ORT-INST-TW	1	ASSY INSTALLATION KIT ORT TWIN	
4	ORT-0400UK	1	ASSY AC BRKT MAIN	
5	ORT-0700UK	1	ASSY AC BRKT SUB	
8	421-7020UK	4	STICKER CAUTION FORK	
9	LB1102	6	STICKER DANGEROUS VOLTAGE	BACK LIDS-4, REAR FLOOR-2
10	ORT-4560UK	1	ASSY LAN COM2	PUT IN LEFT HAND UNIT
12	421-7987-ORT-T	1	STICKER ELEC SPEC ORT TW	MAIN CABI, LHS OF MAIN BASE
14	421-7988-91UK	3	STICKER SERIAL NUMBER UK	1P-1,2P-2,CCT INSIDE TOP DOOR
15	421-8543UK	1	STICKER CABINET L UK	1P
16	421-8544UK	1	STICKER CABINET R UK	2P
18	SGM-3863	2	POLY COVER 1800X950X1700	
19	SPG-0005	24	BLIND CAP	1P-LHS-12, 2P-RHS-12
22	INY-0004	2	BACK LID INY	
23	DYN-0008XUK	2	BACK LID B UK	
24	ORT-1551-AUK	1	STICKER COVER PANEL L	
25	ORT-1556-AUK	1	STICKER COVER PANEL R	
27	LB1046	1	LABEL TESTED FOR ELEC. SAFETY	
28	RAL-XXX-13UK	2	LOCK COVER UK	(R.FLOORS)-2
36	ORT-1551-BUK	1	STICKER LINE L	
37	ORT-1556-BUK	1	STICKER LINE R	
101	601-8956-01	1	EARTH OUTLET WK3001W	LEFT UNIT
102	440034	3	FERRITE-TDK-ZCAT-3035-1330	
201	000-P00412-WB	8	M4X12 MSCR PAN W/FS BLK	(4)-4,(5)-4
202	000-P00408-WB	26	M4X8 MSCR PAN W/FS BLK	(22)-18,(23)-8
203	010-P00412	4	M4X12 S-TITE PAN PAS	(22)-4
204	008-T00408-0C	16	M4X8 TMP PRF TH CRM	(28)-8,(F.FLOORS)-8
205	029-B00620-0B	4	M6X20 SKT BH BLK	(R.FLOORS)-4
206	060-S00600-0B	4	M6 WSHR SPR BLK	(R.FLOORS)-4
207	060-F00600-0B	4	M6 WSHR FORM A FLT BLK	(R.FLOORS)-4
212	050-F00400	2	M4 NUT FLG SER PAS	(10)-2
213	068-441616	2	M4 WSHR 16OD FLT PAS	(10)-2
214	012-P03512-F	2	N6X1/2" S/TAP FLG PAS	(101)-2
303	ORT-64001UK	1	WH POWER HUB	
401	PK0342	2	SLEEVE COCKPIT ORT TWIN	
402	PK0034	2	PALLET WOODEN RALLY	
403	PK0342-LID	2	LID ORT TWIN	

8.3. ORT-10001UK ASSY COCKPIT 1P

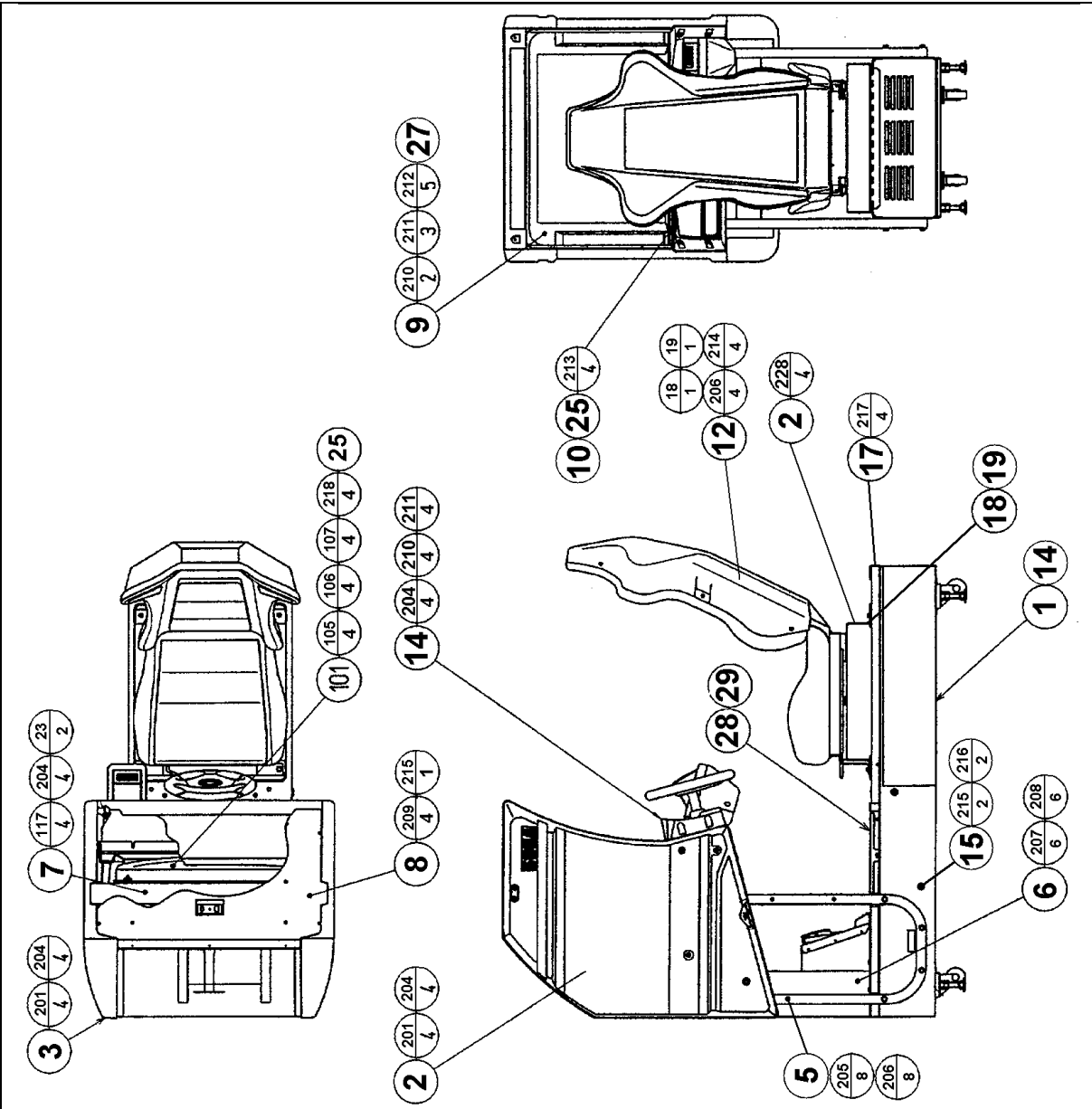

ITEM	PART NO.	QTY	DESCRIPTION	COMPONENT REF.
1	DUT-1120UK	1	ASSY SUB MAIN BASE	
2	ORT-1550UK	1	ASSY MONITOR COVER L 2P	
3	ORT-1555UK	1	ASSY MONITOR COVER R 2P	
4	ORT-2000UK	1	ASSY CONTROL PANEL	
5	POD-1023UK	1	MONITOR STAND	
6	ORT-1100UK	1	ASSY PEDAL BASE ORT	
7	POD-1021UK	1	MONITOR SUPPORT	
8	DUT-1008UK	1	ROOF LID DUT	
9	POD-1022	1	MONITOR MASK	
10	SPG-1005	1	MASK HOLDER	
12	ORT-1600UK	1	ASSY SEAT TWIN 1P	
14	ORT-4500UK	1	ASSY MAIN BD	
15	ORT-4600UK	1	ASSY ELEC BD	
17	FRI-1510UK	1	ASSY BASE LID R	
18	RAL-2007	1	RUBBER HOLDER R TWIN	(12)-1
19	RAL-2008	1	RUBBER HOLDER L TWIN	(12)-1
20	ORT-1502UK	1	STICKER BASE L	
21	ORT-1503UK	1	STICKER BASE R	
22	ORT-1504UK	1	STICKER BASE LID	(17)-1
23	POD-1026UK	4	CRT SPACER (POD)	(5)-2,(7)-2
24	DUT-2031UK	1	FRONT FLOOR UK DUT	FIX DOWN AT NEXT LEVEL UP
25	SRT-1009UK	1	MONITOR SPASHGUARD SRT TW	FIX TO (10)
26	SRT-2031UK	0.9	NEOPRENE RUBBER STRIP 10X3mm	(24)-0.5,(1)-0.4 4X10cm STRIPS
27	OS1004	0.705	DRAFT EXCLDR 4 X7MM BLK x 10M	(9)-705mm ON FRONT LIP
30	440-WS0220UK	1	WARNING STICKER TRAP HAZARD	NEXT TO STEERING GEARS
101	200-5949	1	ASSY CLR DSPL 29 TYPE 31K UK	
105	280-5112	4	BUSH FOR TV	(101)-4
106	280-5113	4	COLLAR FOR TV	(101)-4
107	068-652516	4	M6 WSHR 25OD FLT PAS	(101)-4
108	280-L00716-OS	3	STANDOFF 7OD 4ID 16L	(101)-3 REMOTE BD
109	601-6231-C100	2	EDGING NEW TYPE	TOP OF WIRE COVER -2
110	601-6231-D100	2	EDGING NEW TYPE	INSIDE OF PEDAL BASE -2
111	260-0011-02	1	AXIAL FLOW FAN AC100V 50-60Hz	
112				
113	FN1012	2	MESH GUARD METAL 120mm FAN	(111)-2
114	OS1195	8	RIVET SNAP MOSS SR1811	(113)-8
115	280-A00900-A	20	ROUTER TWIST D9 ADH	
116	280-A00748-PM	4	ROUTER TWIST D7 SO4.8PA	MONITOR STAND HORIZONTAL BAR
117	280-A02048-PM	12	ROUTER TWIST D20 SO4.8PA	WIRE COVER BOX 2X4 CORNER DROP
201	030-000840-SB	12	M8X40 BLT W/S BLK	(2)-4,(3)-4,(7)-4
202	008-B00825-OB	6	M8X25 TMP PRF BH BLK	(4)-6
203	060-S00800-OB	6	M8 WSHR SPR BLK	(4)-6
204	060-F00800-OB	18	M8 WSHR FORM A FLT BLK	(2)-4,(3)-4,(4)-6,(7)-4
205	030-000850-SB	8	M8X50 BLT W/S BLK	(5)-8
206	068-852216-OB	12	M8 WSHR 22OD FLT BLK	(5)-8,(12)-4
207	030-000616-SB	6	M6X16 BLT W/S BLK	(6)-6
208	068-651616-OB	6	M6 WSHR 16OD FLT BLK	(6)-6
209	000-P00408-WB	6	M4X8 MSCR PAN W/FS BLK	(8)-4,(6)-2

Cont.

ITEM	PART NO.	QTY	DESCRIPTION	COMPONENT REF.
210	000-T00530-0B	2	M5X30 MSCR TH BLK	(9)-2
211	000-T00512-0B	3	M5X12 MSCR TH BLK	(9)-3
212	068-552016-0B	5	M5 WSHR 20OD FLT BLK	(9)-5
213	000-F00512	4	M5X12 MSCR CSK PAS	(10)-4
214	030-000820-SB	4	M8X20 BLT W/S BLK	(12)-4
215	032-000425	4	M4X25 W/BLT PAS	(14)-2,(15)-2
216	068-441616	4	M4 WSHR 16OD FLT PAS	(14)-2,(15)-2
217	008-T00512-0B	4	M5X12 TMP PRF TH BLK	(17)-4
218	050-F00600	4	M6 NUT FLG SER PAS	(101)-4
219	000-P00320	3	M3X20 MSCR PAN PAS	(101)-3 REMOTE BD
220	012-HB0512	8	N10X1/2" S/TAP HEX B PAS	(111)-8
221	060-F00500	8	M5 WSHR FORM A FLT PAS	(111)-8
301	TOF-60100UK	1	WH EXT VIEW BUTTON A	
306	600-6373-77-91	1	WIRE HARNESS PLAYER SEL EXT B	
307	TOF-60101UK	1	WH EXT FRONT SP B	
308	FRI-61042UK	1	WIRE HARN EXT VR B	
309	NCR-61011UK	1	WIRE HARN VIEW BUTTON B	
310	600-7009-2500	1	ASSY RGB CA D-SUB 15P 2500MM	
312	FRI-61041UK	1	WIRE HARN EXT MOTOR B	
316	POD-61012UK	1	WIRE HARN 100V EXT COCKPIT	
317	TOF-60015UK	1	WH EXT ENCODER B	
318	NCR-61008UK	1	WH EXT FRONT SP A	
319	POD-61026UK	1	WIRE HARN EXT AC UNIT	
320	TOF-60103UK	1	WH VTS EXT	
323	600-9020-44K	1	WIRE HARN EARTH 200mm M4/M4 K	MON STAND TO WIRE COVER BOX
324	600-9100-44K	2	WIRE HARN EARTH 1000mm M4/M4 K	MON STAND TO MON SUPPORT & C.PNL
325	600-9020-44K	1	WIRE HARN EARTH 200mm M4/M4 K	MON SUPPORT TO ROOF LID
326	600-9060-46K	1	WIRE HARN EARTH 600mm M4/M6 K	MON STAND TO LH BOT OF 101

8.4. DUT-1120UK ASSY SUB MAIN BASE

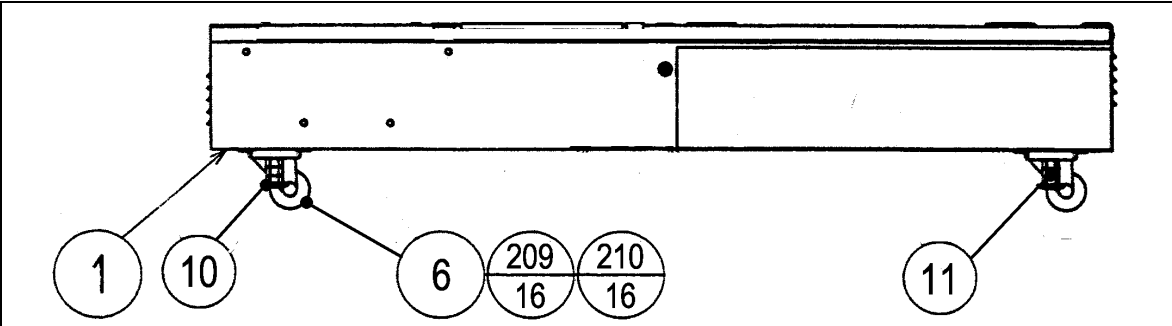

ITEM	PART NO.	QTY	DESCRIPTION	COMPONENT REF.
1	DUT-1121UK	1	MAIN BASE	
6	MA1007	4	CASTOR SWIVEL 63mm NYLON	
10	601-5699UK-01	2	LEG ADJ M16X100 1L/NUT	
11	601-5699UK-03	2	LEG ADJ M16X100 3 L/NUT	
209	030-000816	16	M8X16 BLT PAS	
210	060-S00800	16	M8 WSHR SPR PAS	

8.5. ORT-1550UK ASSY MONITOR COVER L 2P

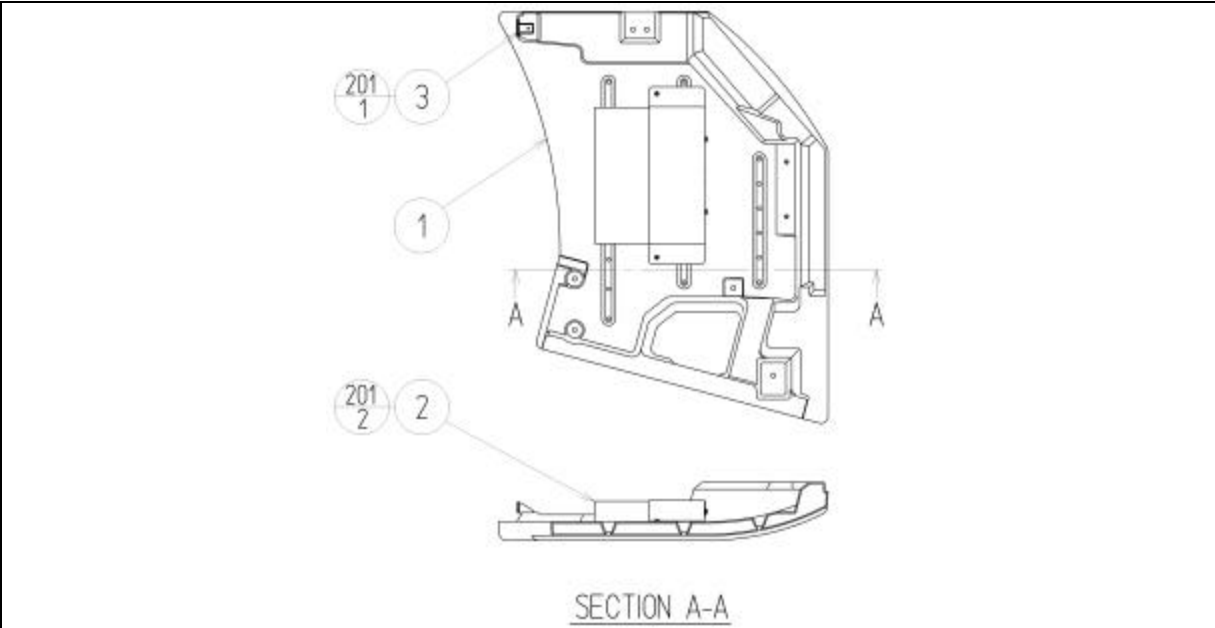

ITEM	PART NO.	QTY	DESCRIPTION	COMPONENT REF.
1	FRI-1035X-A	1	COVER PANEL L BLANK	
2	APC-1560	1	ASSY SPEAKER L	
3	DYN-1032UK	1	MASK BRKT	
201	000-P00408-W	3	M4X8 MSCR PAN W/FS PAS	(2)-2,(3)-1

8.6. APC-1560 ASSY SPEAKER L

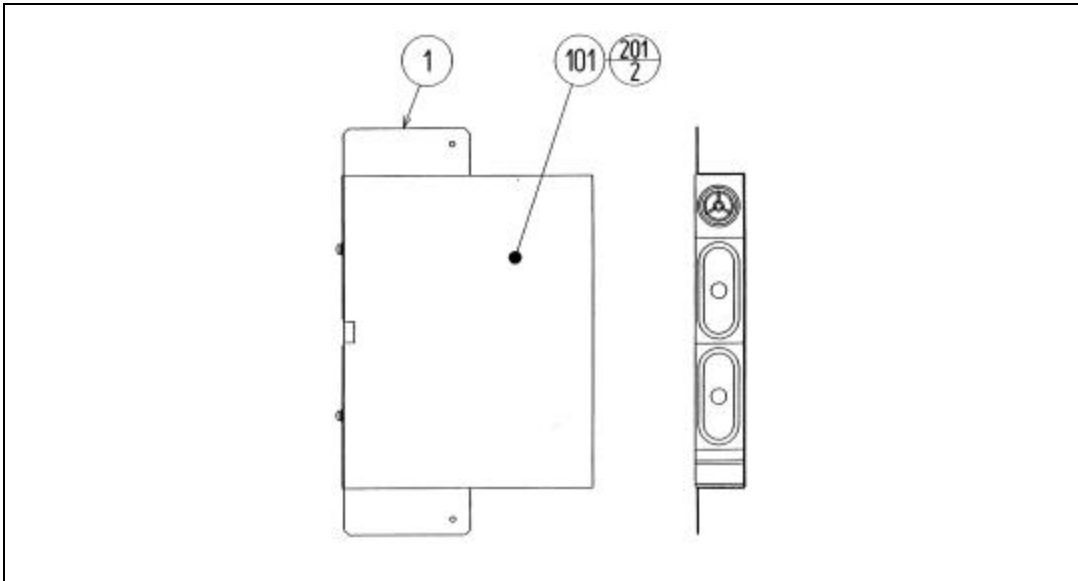

ITEM	PART NO.	QTY	DESCRIPTION	COMPONENT REF.
1	APC-1561	1	SPEAKER BRKT	
101	130-5156	1	SPEAKER BOX 8OHM 20W	TWEETER @ TOP
201	000-P00512-W	2	M SCR PH W/FS M5X12	(101)-2

8.7. ORT-1555UK ASSY MONITOR COVER R 2P

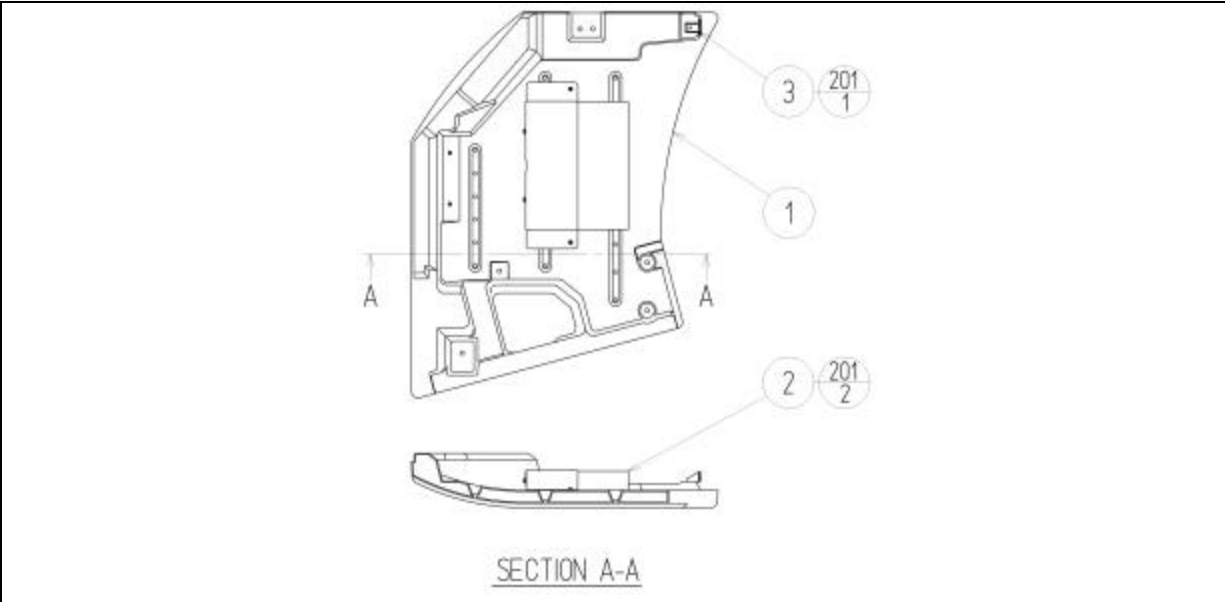

ITEM	PART NO.	QTY	DESCRIPTION	COMPONENT REF.
1	FRI-1036X-A	1	COVER PANEL R BLANK	
2	APC-1565	1	ASSY SPEAKER R	
3	DYN-1032UK	1	MASK BRKT	
201	000-P00408-W	3	M4X8 MSCR PAN W/FS PAS	(2)-2,(3)-1

8.8. APC-1565 ASSY SPEAKER R

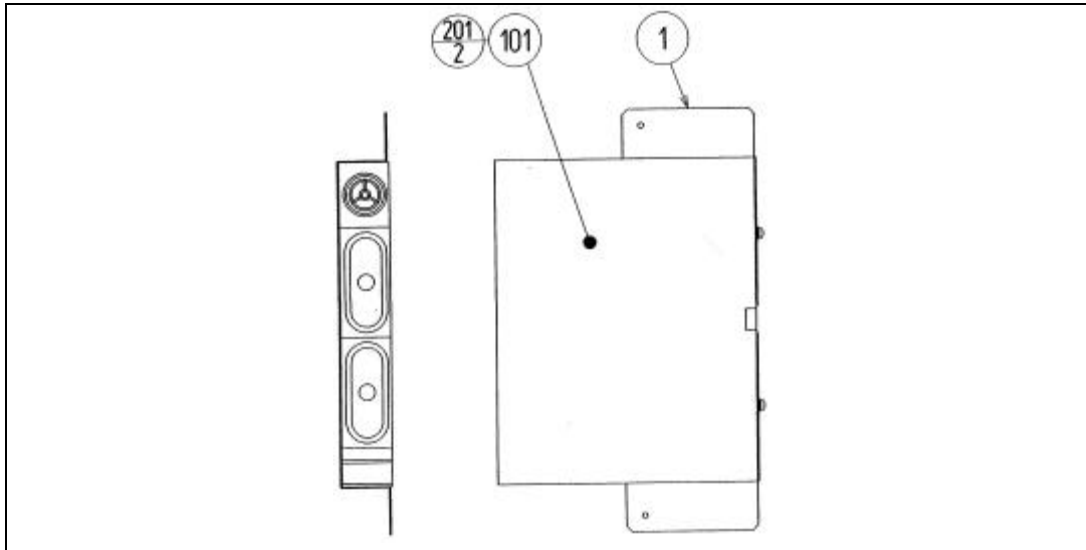

ITEM	PART NO.	QTY	DESCRIPTION	COMPONENT REF.
1	APC-1561	1	SPEAKER BRKT	
101	130-5156	1	SPEAKER BOX 8OHM 20W	TWEETER @ TOP
201	000-P00512-W	2	M SCR PH W/FS M5X12	(101)-2

ITEM	PART NO.	QTY	DESCRIPTION	COMPONENT REF.
1	SPG-2001	1	STEERING WHEEL	
2	DYN-1209X	1	HANDLE COLLAR	
3	FRI-2002	1	STEERING EMBLEM FRI	
4	JBA-2001	1	CONTROL PANEL COVER	
5	FRI-1202UK	1	CONTROL PANEL BRKT TWIN	
6	INY-1204	1	SHIFT COVER INY	
7	DYN-1223X	1	SHIFT COVER B	
8	SRT-1203UK	1	FAN BRKT UK	
9	LMN-1202	1	SHIFT BASE	
10	SPG-2500	1	ASSY HANDLE MECHA	
11	610-0408-91	1	UP/DOWN SHIFTER AL	
12	ORT-2100	1	ASSY SW PLATE	
13	SPG-2039	1	SPACER RING	(1)-1
14	FN1012	1	MESH GUARD METAL 120mm FAN	
15	117-5164UK	1	PLATE START 37x42 UK	
16	DYN-0010UK	1	DENOMI PLATE	
101	260-0011-02	1	AXIAL FLOW FAN AC100V 50-60HZ	AIRFLOW TOWARDS
102	280-A01200-A	4	ROUTER TWIST D12 ADH	
103	280-A02000-A	1	ROUTER TWIST D20 ADH	
104	280-A02048-PM	2	ROUTER TWIST D20 SO4.8 PAN LG	
107	OS1195	5	RIVET SNAP MOSS SR1811	(14)-5
108	509-5440	1	PUSH BTN SW IT GRN W/L DC 14V	(15)-1
201	020-000820	1	M8X20 BLT PAS	(1)-1 (USE ANAEROBIC
202	060-F00800	4	M8 WSHR FORM A FLT PAS	(10)-4
203	060-S00800	5	M8 WSHR SPR PAS	(1)-1,(10)-4
204	050-U00800	4	M8 NUT NYLOK PAS	(10)-4
205	FAS-200013	4	M4X16 SKT CAP CRM	(3)-4
206	000-T00416-0B	3	M4X16 MSCR TH BLK	(4)-3
207	000-P00412-W	6	M4X12 MSCR PAN W/FS PAS	(7)-3,(8)-2,(FAN EARTH)-
208	008-T00516-0B	4	M5X16 TMP PRF TH BLK	(11)-4
209	000-P00312-W	3	M3X12 MSCR PAN W/FS PAS	(101)-3
210	030-000820-S	4	M8X20 BLT W/S PAS	(9)-4
211	050-F00300	2	M3 NUT FLG SER PAS	(15)-2
212	000-T00412-0C	4	M4X12 MSCR TH CRM	(12)-4
215	050-F00400	1	M4 NUT FLG SER PAS	EARTHS - 2
216	000-T00412-0B	4	M4X12 MSCR TH BLK	(16)-4
301	600-6873-043	1	WIRE HARN VIEW BUTTON	
302	TOF-60018UK	1	WH EXT SHIFTER	
303	CKT-62037UK	1	WIRE HARN ENCODER EXT 2	
304	CKT-62036UK	1	WIRE HARN SERVO OUTPUT EXT 2	
305	ORT-61047UK	1	WIRE HARN CONT PNL FAN	
306	TOF-60016UK	1	WH EXT VOLUME C	
308	TOT-61078UK	1	WH PLAYER SELECT SW	

8.10. SPG-2500 ASSY HANDLE MECHA

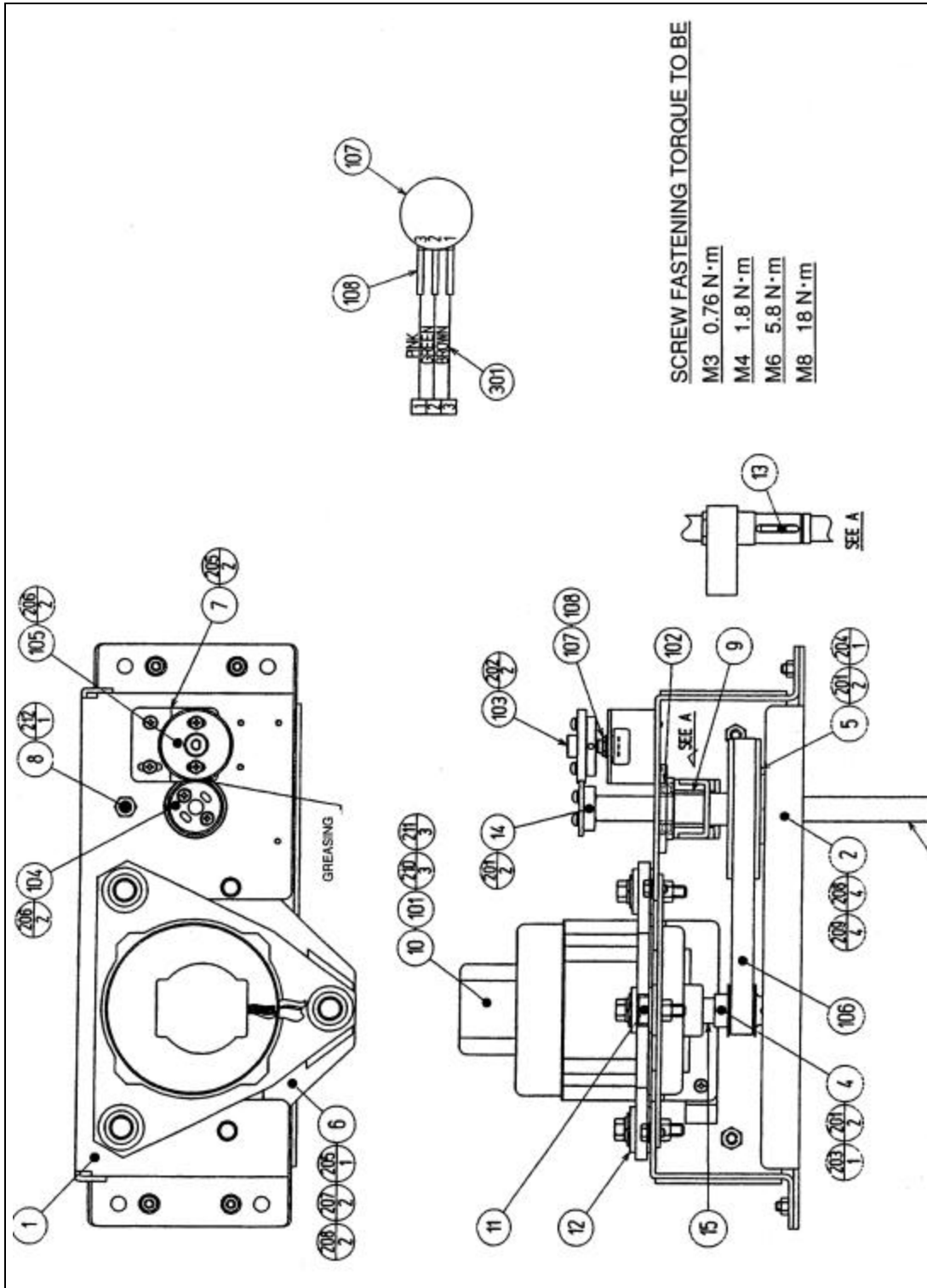

ITEM	PART NO.	QTY	DESCRIPTION	COMPONENT REF.
1	SPG-2500	1	HANDLE BASE	
2	SPG-2500	1	BASE LID	
3	SPG-2500	1	HANDLE SHAFT	
4	SPG-2500	1	PULLEY 20 S5M	
5	SPG-2500	1	PULLEY 60 S5M	
6	SPG-2500	1	MOTOR BRKT	
7	SPG-2500	1	VR BRKT	
8	SPG-2500	1	STOPPER BOLT	
9	SPG-2500	1	STOPPER RUBBER	
10	SPG-2500	1	KEY 4X4X40	
11	SPG-2500	3	MOTOR SPACER	
12	SPG-2500	3	MOTOR COLLAR	
13	SPG-2500	1	STOPPER KEY	
14	SPG-2500	1	ADJUST RING	
15	SPG-2500	1	MOTOR SHAFT COLLAR	
101	SPG-2500	1	SERVO MOTOR 500W NEW	
102	SPG-2500	2	BEARING 17 (NSK 6003ZZ)	
103	SPG-2500	1	GEAR HOLDER	
104	SPG-2500	1	GEAR 48	
105	SPG-2500	1	GEAR 64	
106	SPG-2500	1	TIMING BELT (150 S5M 475)	
107	SPG-2500	1	VOL CONT B-5K OHM	
108	SPG-2500	3	SUMITUBE F F 20MM	
201	SPG-2500	6	SET SCR HEX SKT CUP P M4X8	
202	SPG-2500	2	SET SCR HEX SKT CUP P M3X8	
203	SPG-2500	1	STP RING BLK OZ S12	
204	SPG-2500	1	STP RING BLK OZ S20	
205	SPG-2500	3	M SCR PH W/FS M4X8	
206	SPG-2500	4	M SCR PH W/FS M4X12	
207	SPG-2500	2	HEX BLT W/S M6X12	
208	SPG-2500	6	FLT WSHR M6	
209	SPG-2500	4	U NUT M6	
210	SPG-2500	3	HEX BLT W/S M8X40	
211	SPG-2500	3	FLT WSHR 8.5-22 X1.6	
212	SPG-2500	1	U NUT M8	
301	SPG-2500	1	WIRE HARN ASSY HANDLE MECHA VR	

8.11. ORT-2100UK-ASSY SW PLATE

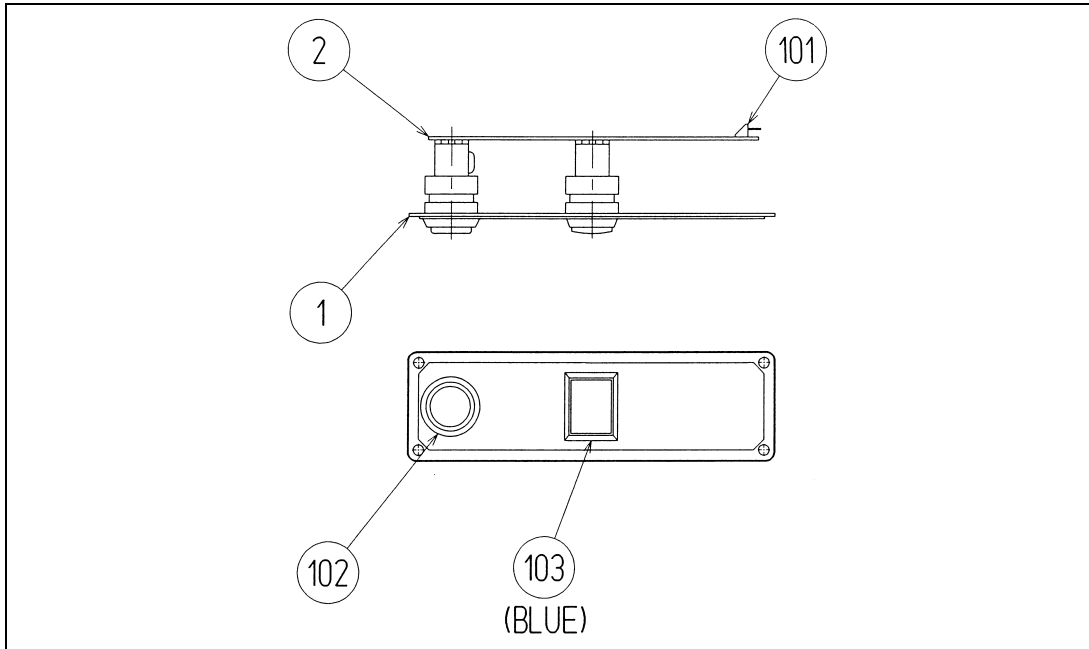

ITEM	PART NO.	QTY	DESCRIPTION	COMPONENT REF.
1	ORT-2101	1	BUTTON PLATE	
2	ORT-2102	1	STICKER START/VIEW	
3	171-6478B	1	PC BD LIGHTING SWX5	
101	212-5205-12	1	CONN JST M 12P RTA	
102	509-5560-Y	1	PB SW W/L 6V 1L Y LW1L-15VY	
103	509-5561-R	1	PB SW W/L 6V 5L R LW5L-15VR	

8.12. ORT-1100UK ASSY PEDAL BASE ORT

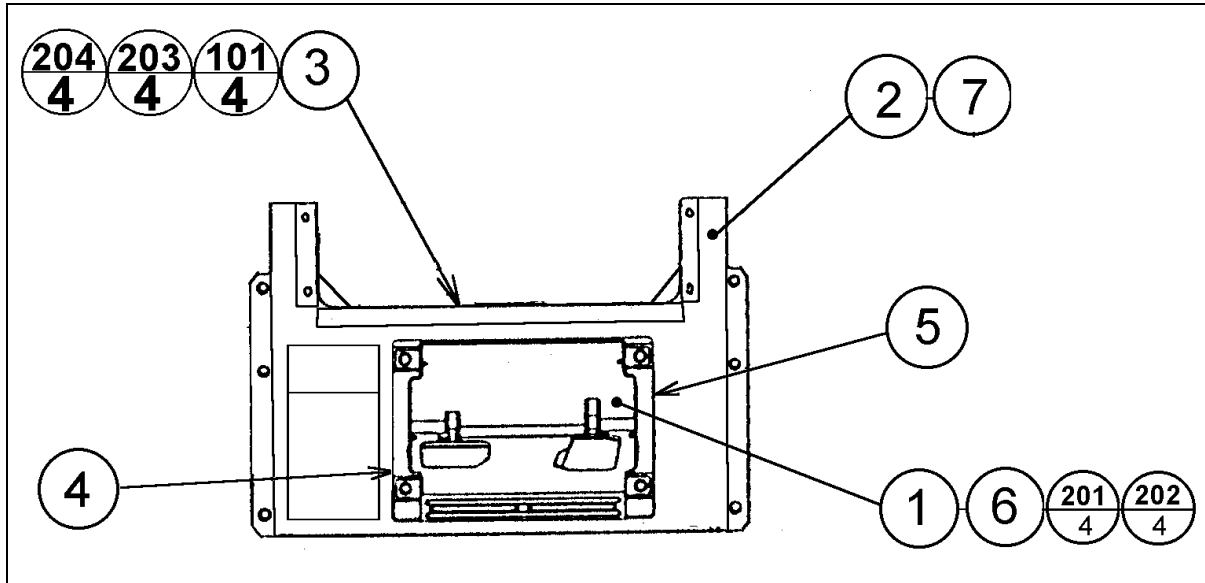

ITEM	PART NO.	QTY	DESCRIPTION	COMPONENT REF.
1	SPG-2200	1	ASSY BRAKE & ACCELL	
2	TOF-1501UK	1	PEDAL BASE	
3	FZR-1021UK	1	WIRE COVER BOX	
4	SPG-2222UK	1	ANTI FINGER TRAP PLATE LEFT	
5	SPG-2223UK	1	ANTI FINGER TRAP PLATE RIGHT	
6	SPG-2224UK	1	PEDAL GASKET	
7	SRT-2031UK	0.52	NEOPRENE RUBBER STRIP 10	(2)-520mm X1 INSIDE FLANGE
101	280-A01200-A	6	ROUTER TWIST D12 ADH	WIRE COVER BOX
201	068-852216-0B	4	M8 WSHR 22OD FLT BLK	(1)-4
202	030-000820-SB	4	M8X20 BLT W/S BLK	(1)-4
203	000-P00408-WB	4	M4X8 MSCR PAN W/FS BLK	(3)-4
204	050-F00400	3	M4 NUT FLG SER PAS	(3)-3 EARTHS
301	600-9050-44K	1	WIRE HARN EARTH 500mm M4/M4 K	WIRE COVER TO MAIN BASE

8.13. SPG-2200 ASSY BRAKE & ACCELL

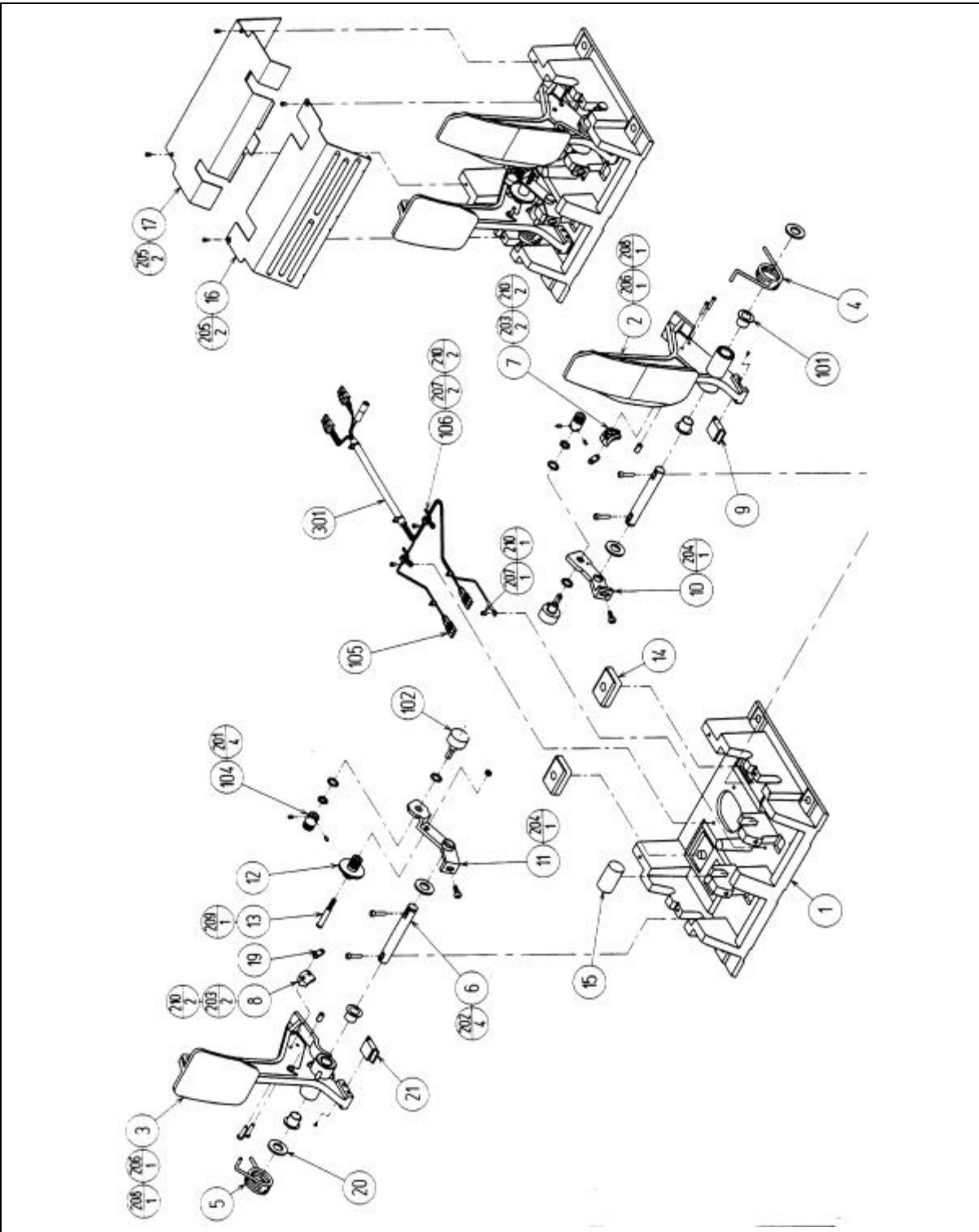

ITEM	PART NO.	QTY	DESCRIPTION	COMPONENT REF.
1	SPG-2201	1	BASE	
2	SPG-2202	1	ACCEL PEDAL	
3	SPG-2203	1	BRAKE PEDAL	
4	SPG-2204	1	ACCEL SPRING	
5	SPG-2205	1	BRAKE SPRING	
6	SPG-2206	2	SHAFT	
7	SPG-2207	1	ACCEL	
8	SPG-2208	1	BRAKE GEAR	
9	SPG-2209	1	NEUTRAL STOPPER	
10	SPG-2210	1	VR PLATE ACCEL	
11	SPG-2211	1	VR PLATE BRAKE	
12	SPG-2212	1	AMPL GEAR	
13	SPG-2213	1	GEAR SHAFT	
14	SPG-2214	2	STOPPER	
15	SPG-2215	1	RUBBER CUSHION	
16	SPG-2216	1	COVER	
17	SPG-2217	1	VR COVER	
19	SPG-2219	2	GEAR STAY	
20	SPG-2220	4	WSHR	
21	SPG-2221	1	NEUTRAL STOPPR D	
101	100-5263	4	BEARING 12 (OILES 80F-1212)	
102	220-5484	2	VOL CONT B-5K OHM	
104	601-7944	2	GEAR 15	
105	310-5029-F15	6	SUNITUBE F F15MM	
106	280-0419	2	HARNESS LUG	
201	028-A00304-P	4	SET SCR HEX SKT CUP P M3X4	
202	020-000516-OZ	4	HEX SKT H CAP SCR BLK OZ M5X16	
203	000-P00420	4	M SCR PH M4X20	
204	000-P00508-W	2	M SCR PH W/FS M5X8	
205	000-T00408-OC	4	M SCR TH CRM M4X8	
206	FAS-450005	2	SPR PIN BLK OZ 6X10	
207	000-P00405	3	M SCR PH M4X5	
208	FAS-000001	2	M SCR TH CRM M3X6	
209	050-H00500	1	HEX NUT M5	
210	060-F00400	7	FLT WSHR M4	

8.14. ORT-1600UK ASSY SEAT TWIN 1P

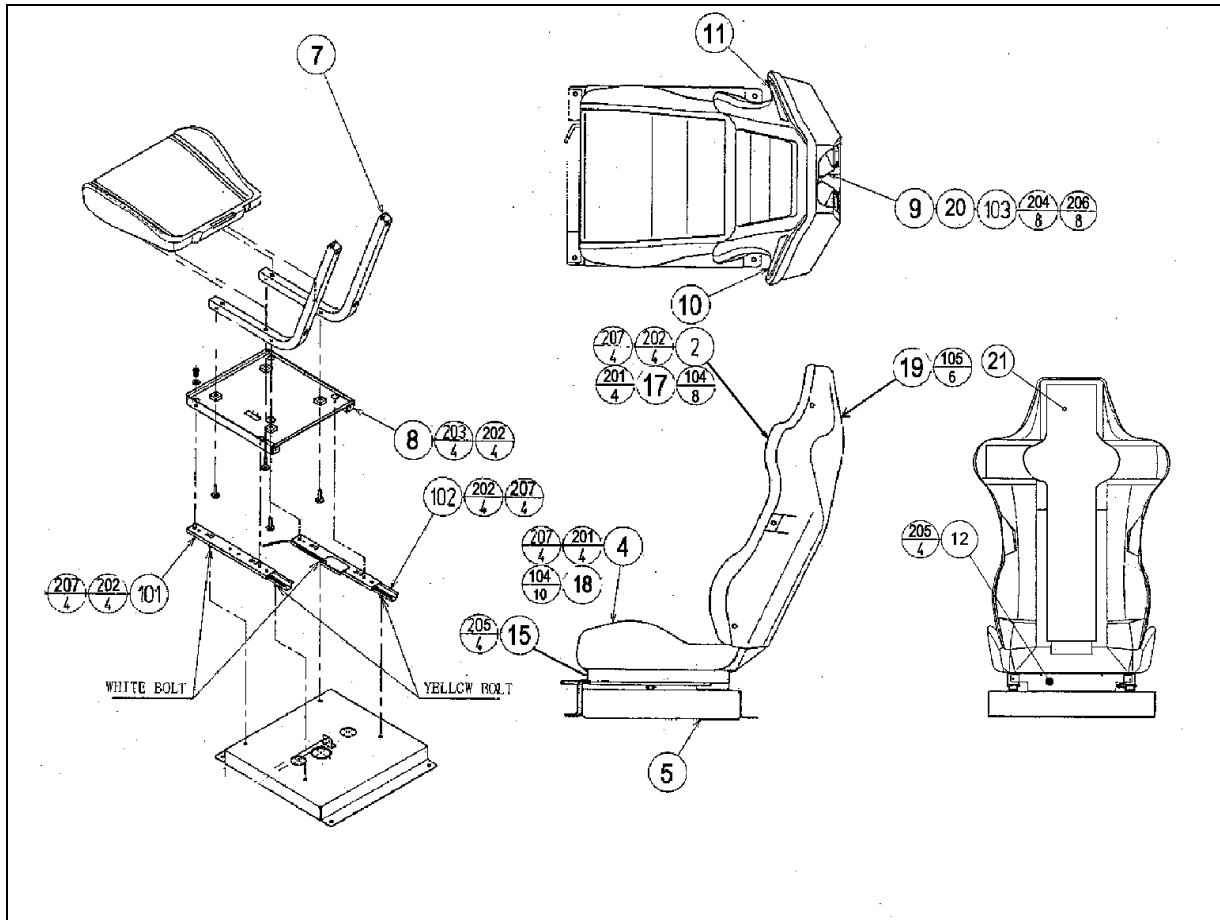

ITEM	PART NO.	QTY	DESCRIPTION	COMPONENT REF.
2	SPG-2401-AUK	1	UPPER SEAT BLANK	
4	SPG-2402-AUK	1	LOWER SEAT BLANK	
5	STC-1603	1	SEAT BASE	
7	STC-1604	2	SEAT FRAME	
8	STC-1606	1	SEAT MOUNT TRAY	
9	STC-1607	2	SP MOUNT BRKT	
10	STC-1608	1	SPEAKER NET L	
11	STC-1609	1	SPEAKER NET R	
12	STC-1610	1	SAFETY GUARD	
14	STC-1612	2	PROTECT RUBBER	
15	STC-1613	1	SAFETY GUARD F	
16	OS1004	0.8	DRAFT EXCLDR 4 X7MM BLK x 10M	(103)-0.8M
17	SPG-2401-BUK	1	UPPER SEAT INSERT	(2)-1
18	SPG-2402-BUK	1	LOWER SEAT INSERT	(4)-1
19	ORT-1601-AUK	1	SEAT REAR COVER BLANK	
20	SRT-2409	2	SHOULDER PAD	INBETWEEN SPKR NETS &
21	ORT-1603-BUK	1	STICKER SEAT BACK	
101	601-9059-91	1	SEAT RAIL L	

Cont.

ITEM	PART NO.	QTY	DESCRIPTION	COMPONENT REF.
102	601-9060-91	1	SEAT RAIL R	
103	130-5186-91	2	DUMMY SPEAKER	
104	280-K02529-WX	18	DRIVE FASTENER 25FH 24L 7.9DIA	(17)-8,(18)-10
105	280-5297	6	SCRIVET 8 1K31	(19)-6
201	030-000850-S	8	M8X50 BLT W/S PAS	(2)-4,(4)-4
202	068-852216	20	M8 WSHR 22OD FLT PAS	(2,4,8,101,102)-4EA
203	030-000816-S	4	M8X16 BLT W/S PAS	(8)-4
204	000-P00410-W	8	M4X10 MSCR PAN W/FS PAS	(9)-8
205	000-T00408-0B	8	M4X8 MSCR TH BLK	(12)-4,(15)-4
206	012-P03512-F	8	N6X1/2" S/TAP FLG PAS	(103)-8
207	050-U00800	8	M8 NUT NYLOK PAS	(101)-4,(102)-4

8.15. ORT-4500UK ASSY MAIN BD

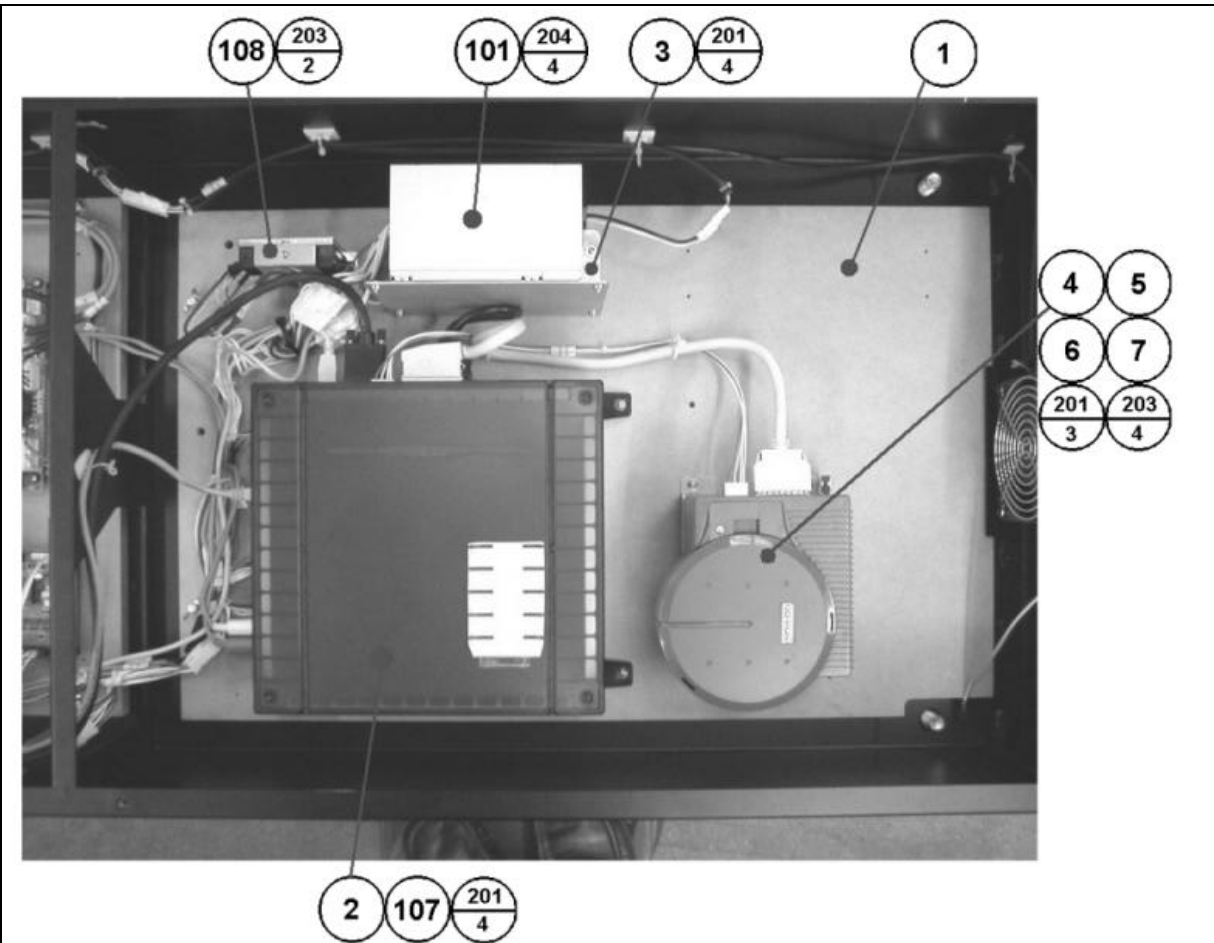

ITEM	PART NO.	QTY	DESCRIPTION	COMPONENT REF.
1	ORT-4501UK	1	MAIN BD BASE	
2	843-0005D-02	1	ASSY CASE BOX ORT EXP	
3	APC-4002	1	SW REG BRKT	
4	105-5435	1	GD DRIVE BRKT STD	
5	LB1111	1	STICKER PLEASE RECYCLE	
6	610-0617	1	GD-ROM DRIVE UNIT NAOMI	SHIP BOX WITH MACHINE
7	610-0652-0004	1	GD SOFT ORT	
8			KEY CHIP	
101	400-5443	1	SW REGU FOR CHIHIRO	
104	354081	4	TWIST LOK BHKL-450-4	
105	354083	4	(A)TWIST N LOK BHKL-750-4	
106	280-A00964-W X	6	ROUTER TWIST D09 SO6.4 WOOD	
107	LB1101	1	STICKER WARNING BATTERY	GAME BD
108	610-0674	1	POWER PROTECT UNIT FOR	
201	000-P00416-W	11	M4X16 MSCR PAN W/FS PAS	(2)-4,(4)-3,(3)-4
203	012-P00410-F	6	N8X3/8" S/TAP FLG PAS	(6)-4,(108)-2
204	000-P00408-W	4	M4X8 MSCR PAN W/FS PAS	(101)-4
307	600-7247-500	1	CABLE SCSI ST-L TYPE2 500MM	
308	ORT-60101UK	1	WH POWER PROTECT UNIT	
309	HDT-60100UK	1	WH POWER GD ROM	

8.16. ORT-4600UK ASSY ELEC BD

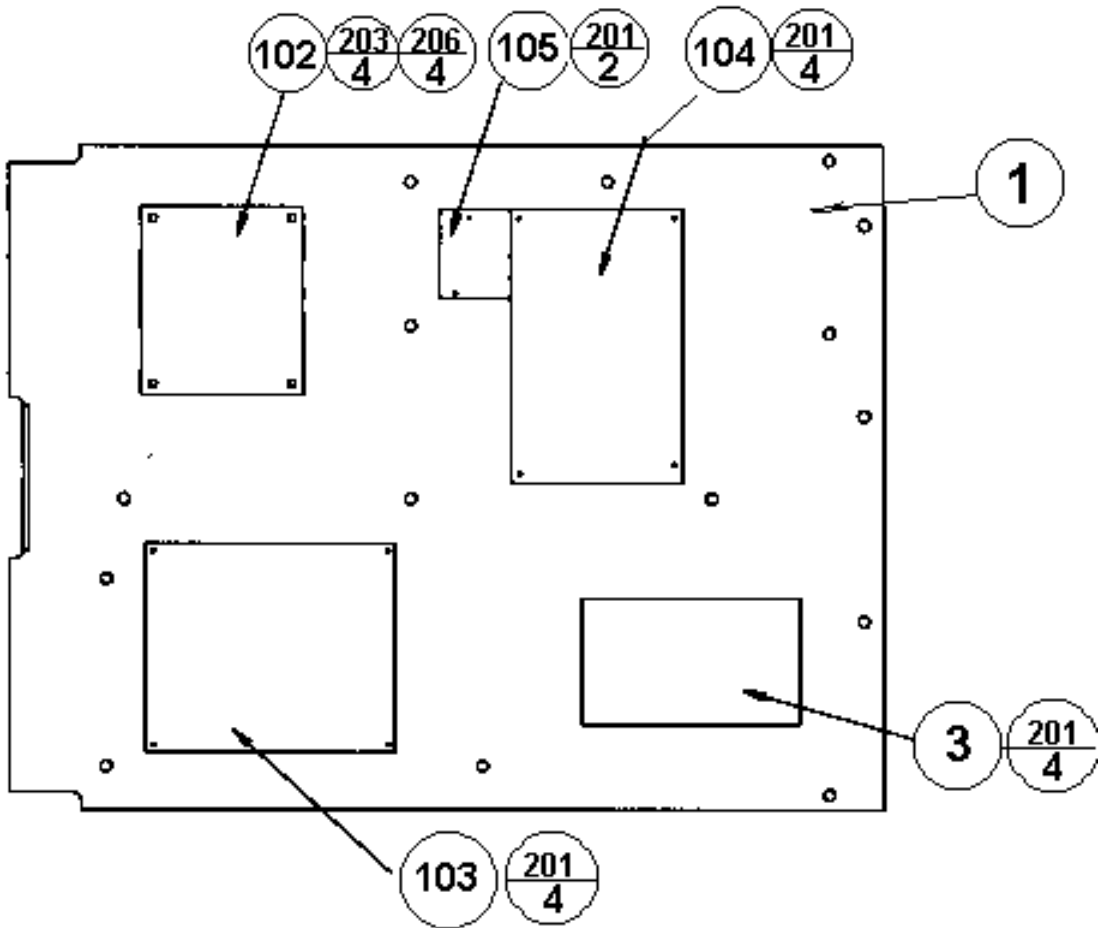

ITEM	PART NO.	QTY	DESCRIPTION	COMPONENT REF.
1	TOF-4601UK	1	WOODEN BASE ELEC	
3	837-13551-92	1	I/O CONTROL BD FOR JVS	
102	560-5394UK	1	TRANSFORMER DUT TW	
103	838-13578	1	PWR AMP 2CH & MIXER	
104	838-14174	1	SERVO MOTOR DRIVE BD MIDI	
105	838-11856CE-02	1	CONNECT BD W/FUSE 6.3A CE	
107	354081	11	TWIST LOK BHKL-450-4	HOLES IN BASE
108	354083	10	(A)TWIST N LOK BHKL-750-4	HOLES IN BASE
109	280-A00964-WX	12	ROUTER TWIST D09 SO6.4 WOOD X	HOLES IN BASE
201	012-P00325	14	N4X1" S/TAP PAN PAS	(3)-4,(103)-4,(104)-4,(105)-2
203	000-P00416-W	4	M4X16 MSCR PH W/FS PAS	(102)-4
206	068-441616	4	M4 WSHR 16OD FLT PAS	(102)-4
301	600-7141-100	1	CABLE JVS TYPE A-B 100CM	
302	600-6985-006UK	1	WIRE HARN 100V OUT	
303	FRI-61003UK	1	WIRE HARN CONN BD B	
305	FRI-61027UK	1	WIRE HARN EXT AC100V A	
306	TOF-60104UK	1	PWR AMP 14V AC IN	
307	NCR-61002UK	1	WH AMP VR	

Cont.

ITEM	PART NO.	QTY	DESCRIPTION	COMPONENT REF.
309	NCR-61004UK	1	WH AMP SP F	
310	ORT-60001UK	1	WH CONN BD OUT A HUB	
311	TOF-60007UK	1	WH MIDI	
312	TOF-60008UK	1	WH ELEC BD I/O PWR	
313	TOF-60009UK	1	WH I/O BD	
314	TOF-60105UK	1	WH I/O BRD A/D	
315	POD-61057UK	1	WH EARTH AC UNIT	
316	FRI-61030UK	1	WIRE HARN EXT MOTOR A	
317	TOF-60011UK	1	WH EXT ENCODER A	
318	TOF-60021UK	1	WH EXT AC100V B	
319	TOF-60006UK	1	WH MAIN BD SOUND	

8.17. FRI-1510UK ASSY BASE LID R

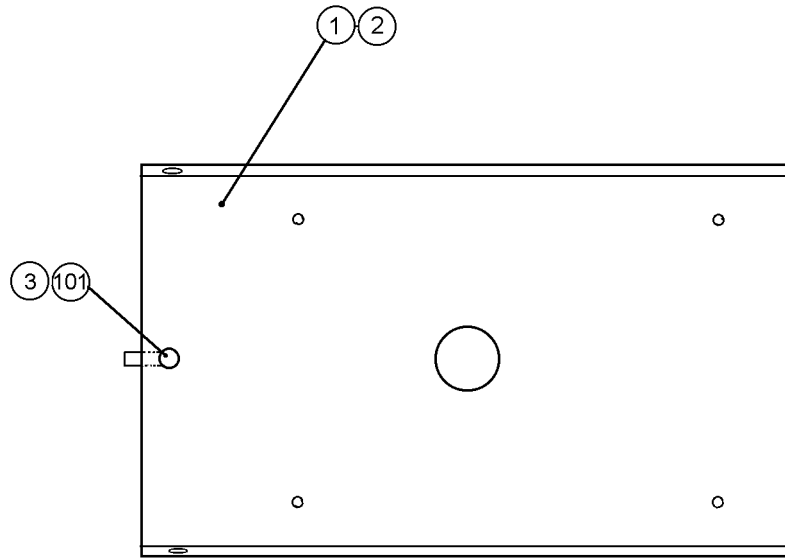

ITEM	PART NO.	QTY	DESCRIPTION	COMPONENT REF.
1	DUT-1511UK	1	BASE LID R	
2	DUT-1511-CUK	1	GASKET STRIP	(1)-1
3	DUT-1511-DUK	1	LOCK TONGUE DUT	(101)-1
101	220-5575UK	1	LOCK	
201	050-F00400	1	M4 NUT FLG	(301)-1
301	600-9020-44K	1	WIRE HARN EARTH 200mm M4/M4 K	R.FLOOR TO MAIN BASE

8.18. ORT-INST-TW ASSY INSTALLATION KIT ORT TWIN

ITEM	PART NO.	QTY	DESCRIPTION	COMPONENT REF.
1	ORT-0200UK	1	ASSY BILLBOARD	
2	FRI-0300UK	1	ASSY COINCHUTE TOWER FRI	
3	ORT-0500UK	1	ASSY WIRE COVER ORT TWIN	
4	DYN-0013	1	JOINT PIPE	
5	DYN-0006XUK	1	AC COVER B	
6	SRT-0018UK	1	AC COVER C	
7	DYN-0019UK	1	AC COVER D	
8	RAL-XXX-14UK	1	TIE BRACKET RALLY	
9	SPG-0008	2	BILLBOARD HOLDER	
10	422-0922UK	1	PLAY INSTR SH ORT TWIN MULTI	
11	422-0923UK	1	SUB INSTR SH ORT TWIN MULTI	
13	PK0344	1	INST KIT BOX ORT TWIN	
18	220-5753	1	VOL CONT B-5K OHM (TOCOS)	spare
19	PK0343	0.5	PALLET INST KIT	
101	440-CS0186UK	2	STICKER C EPILEPSY MULTI	
201	030-000825-SB	20	M8X25 BLT W/S BLK	(1,2,4)-4EA,(9)-8
202	068-852216-0B	20	M8 WSHR 22OD FLT BLK	(1,2,4)-4EA,(9)-8
203	000-P00412-WB	15	M4X12 MSCR PAN W/FS BLK	(3)-5,(5)-4,(6)-2,(7)-4
204	050-F00400	3	M4 NUT FLG SER PAS	(AC UNITS)-1EA, (2)-1
401	420-5827	1	SERVICE MANUAL SANWA 31K	
402	420-6796-02UK	1	SERVICE MANUAL ORT TWIN	
403	OS1019	2	SELF SEAL BAG 9X12.3/4	
404	540-0006-01	1	WRENCH M4 TMP PRF	
405	540-0007-01	1	WRENCH M5 TMP PRF	
406	540-0009-01	1	WRENCH M8 TMP PRF	
407	220-5484	1	VOL CONT B-5K OHM	
408	SAECE-xxx	1	DECLARATION OF CONFORMITY	DECLARATION OF
409	514-5078-5000	2	FUSE 5X20 CERAMIC SB 5000mA	
411	420-6620UK	1	SERVICE MANUAL GD ROM SYSTEM	
416	509-5704	1	SW MICRO TYPE (OMRON K3L13)	

8.19. ORT-0200UK ASSY BILLBOARD

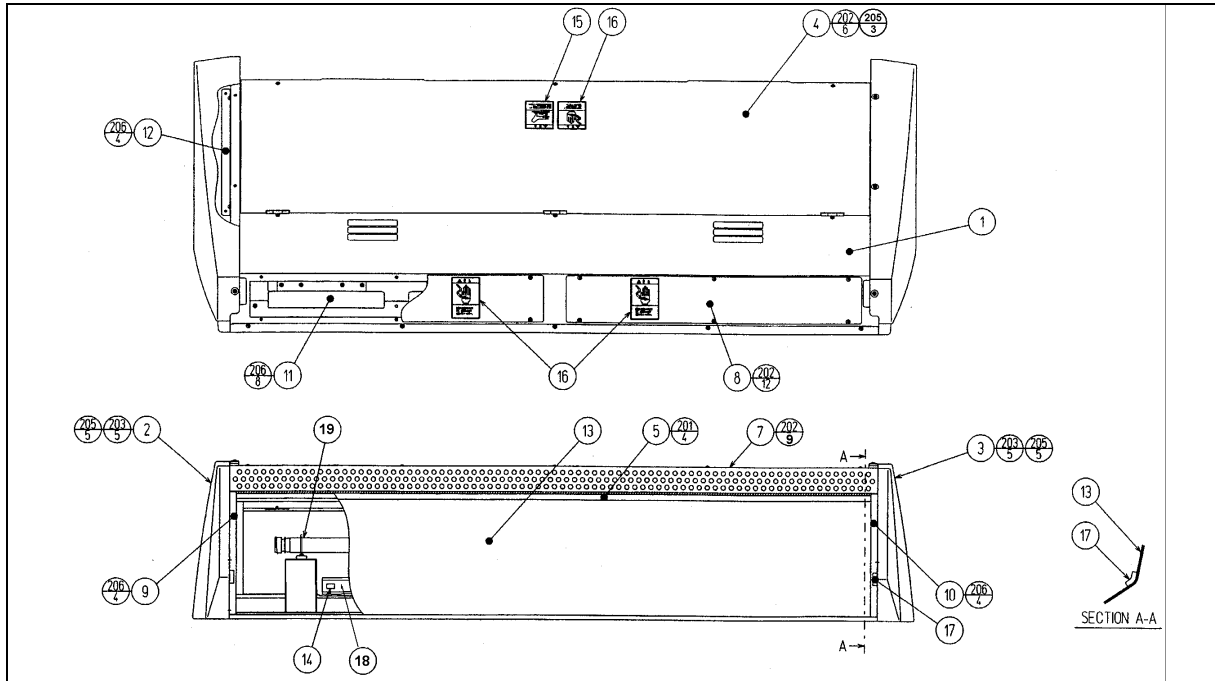

ITEM	PART NO.	QTY	DESCRIPTION	COMPONENT REF.
1	FRI-0201UK	1	BILLBOARD BOX	
2	FRI-0202	1	SIDE COVER L	
3	FRI-0203	1	SIDE COVER R	
4	FRI-0204UK	1	BILLBOARD LID	
5	FRI-0205	1	UPPER SASH	
7	ORT-0207UK	1	UPPER COVER	
8	FRI-0208	2	UPPER LID	
9	FRI-0209	1	SASH SIDE L	
10	FRI-0210	1	SIDE SASH R	
12	VOT-0208	2	SIDE COVER BRKT	
13	ORT-0215UK	1	BILLBOARD PLATE ORT TWIN	
14	421-7501-10	1	STICKER FL 40W	
15	LB1104	1	STICKER CAUTION, HOT SURFACE	ON BACK LID
16	LB1102	3	STICKER DANGEROUS VOLTAGE	BACK LID-1, UPPER LID-1EA
17	FRI-0211	2	CUSHION SPONGE 40	
18	390-5695-40-CUK	1	FL TRAY 110V 40W (T12)	
19	390-5695-40-BUK	1	FL TUBE 40W 4' DIA 1.5" T12	
20	280-A00900-A	7	ROUTER TWIST D9 ADH	
202	000-T00408-0B	27	M4X8 MSCR TH BLK	(4)-6,(7)-9,(8)-12
203	000-T00412-0B	10	M4X12 MSCR TH BLK	(2)-5,(3)-5
205	068-441616-0B	13	M4 WSHR 16OD FLT BLK	(2)-5,(3)-5,(4)-3
206	000-P00408-W	12	M4X8 MSCR PAN W/FS PAS	(9)-4,(10)-4,(12)-4
207	050-F00400	5	M4 NUT FLG SER PAS	(101)-2,(EARTHS)-3
210	000-P00408	2	M4X8 MSCR PAN PAS	(102)-2
302	600-7064-031UK	1	WIRE HARN FL	
303	600-9020-44K	1	WIRE HARN EARTH 200mm M4/M4 K	B/BD BOX B/BD LID

8.20. FRI-0300UK ASSY COINCHUTE TOWER FRI

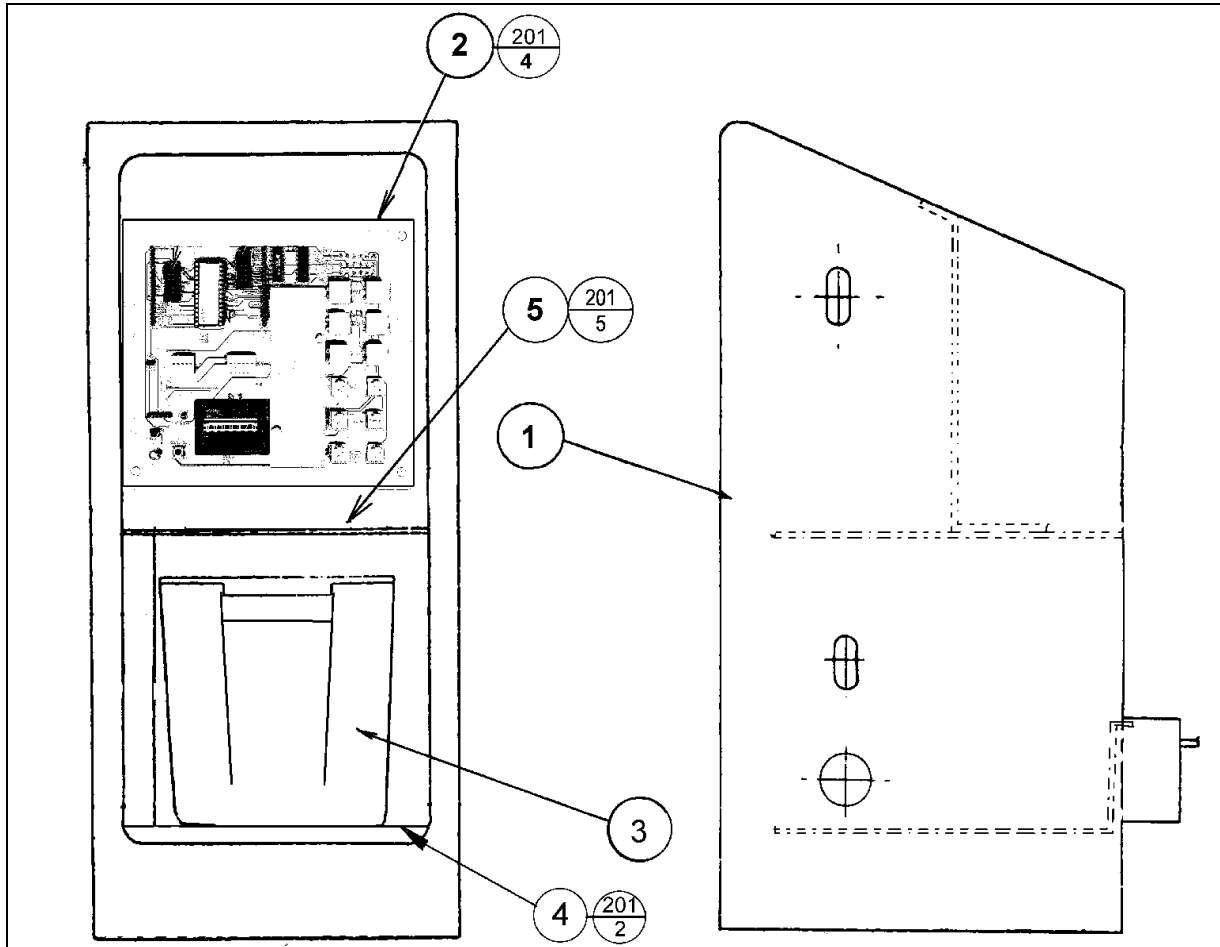

ITEM	PART NO.	QTY	DESCRIPTION	COMPONENT REF.
1	ECA-0301UK	1	COIN CHUTE TOWER ECA	
2	VTS-FRI-T	1	VTS BOARD FRI TWIN	
3	PP1087	1	BOX CASH FOR MINI DOOR	
4	SRT-0302UK	1	CCT FLOOR TWIN	
5	DUT-0302UK	1	COIN PATH PLATE	FIX TO TOP OF VAULT ROOF
201	000-P00410-W	11	M4X10 MSCR POSI PAN W/FS	(2)-4,(4)-2,(5)-5
301	FRI-61056UK	1	WIRE HARN VTS BOARD	

8.21. ORT-0500UK ASSY WIRE COVER ORT TWIN

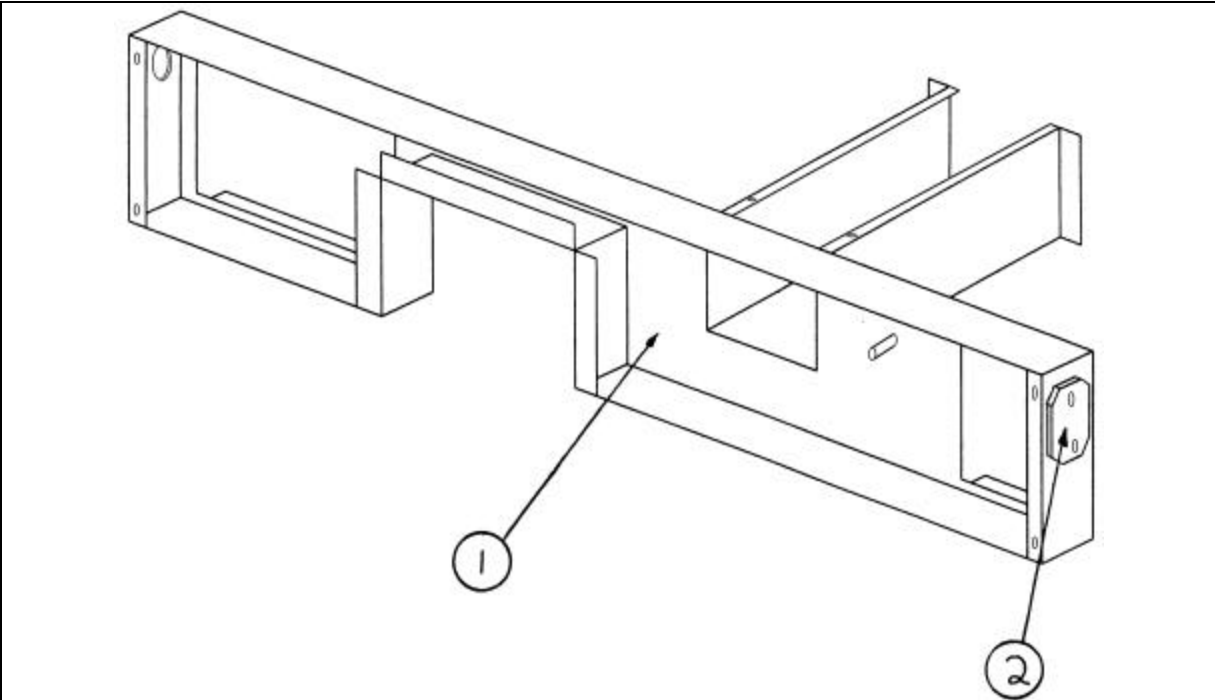

ITEM	PART NO.	QTY	DESCRIPTION	COMPONENT REF.
1	DYN-0005UK	1	AC COVER A	
2	DYN-0009UK	2	HOLE LID	(1)-2
101	600-7269-0500	2	ASSY LAN CABLE 0500CM	
201	000-P00308-WB	4	M3X8 MSCR PAN W/FS BLK	(2)-4
202	050-F00400	1	M4 NUT FLG SER PAS	EARTH - 1
203	280-A02000-A	5	ROUTER TWIST D20 ADH	(1)-5
301	600-6817-104	1	WIRE HARN EXT AC (SPG)	
302	600-6817-102	1	WIRE HARN EXT TOWER L (SPG)	
303	600-6817-103	1	WIRE HARN EXT TOWER R (SPG)	
304	600-6373-76	1	WIRE HARNESS PLAYER SEL EXT A	
305	600-9075-44K	1	WIRE HARN EARTH 750mm M4/M4 K	SUB AC-AC COVER
306	600-9030-44K	1	WIRE HARN EARTH 300mm M4/M4 K	MAIN AC-AC COVER
307	600-9040-45K	1	WIRE HARN EARTH 400mm M4/M5 K	AC COVER - CCT

8.22. ORT-0400UK ASSY AC BRKT MAIN

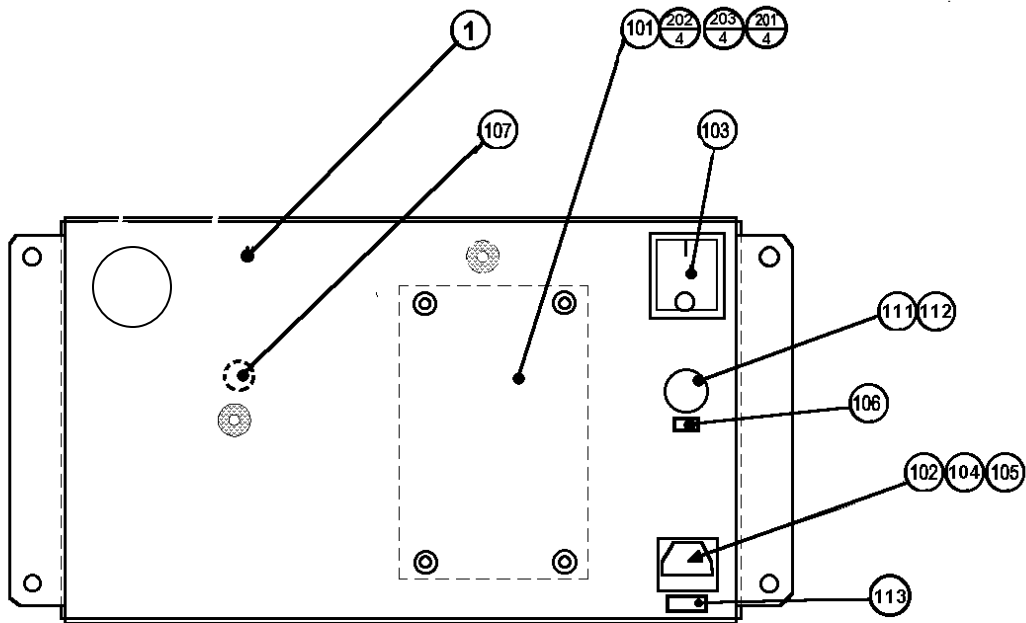

ITEM	PART NO.	QTY	DESCRIPTION	COMPONENT REF.
1	ORT-0401UK	1	AC BRKT UK	
101	EP1379	1	FILTER EMI 10A ARCOTRONICS	
102	EP1302	1	EUROSOCKET FUSED 10A 250Vac	
103	EP1303	1	SWITCH ROCKER DPST 10A 250Vac	
104	514-5078-10000	1	FUSE 5X20 CERAMIC SB 10000mA	IEC INLET
105	310-5029-D508	5	HEAT SHRINK SLEEVING 50.8DIA	OVER ITEM 102(50MM OVER SOCKET)
106	421-6595-5000-T	1	STICKER FUSE 5000mA TYPE T	FUSE HOLDER
107	LB1096	1	STICKER PROTECTIVE EARTH	EARTH POINT INSIDE
111	EP1334	1	FUSE HOLDER 20mm 10A 240Vac	
112	514-5078-5000	1	FUSE 5X20 CERAMIC SB 5000mA	
113	421-6595-10000T	1	STICKER FUSE 10000mA TYPE T	IEC INLET
114	360168	1	SNAP-BUSHING-HEYCO-400 2182	
201	060-S00300	4	M3 WSHR SPR PAS	(101)-4
202	060-F00300	4	M3 WSHR FORM A FLT PAS	(101)-4
203	000-P00310	4	M3X10 MSCR PAN PAS	(101)-4
204	050-F00400	3	M4 NUT FLG SER PAS	(INSIDE EARTH)-2,(OUTSIDE)-1
301	600-6873-001UK	1	WIRE HARN XFMR IN	
303	600-9030-44K	1	WIRE HARN EARTH 300mm M4/M4 K	AC BRKT TO MAIN BASE
304	600-9040-45K	1	WIRE HARN EARTH 400mm M4/M5 K	AC BRKT - XFMR

8.23. ORT-0700UK ASSY AC BRKT SUB

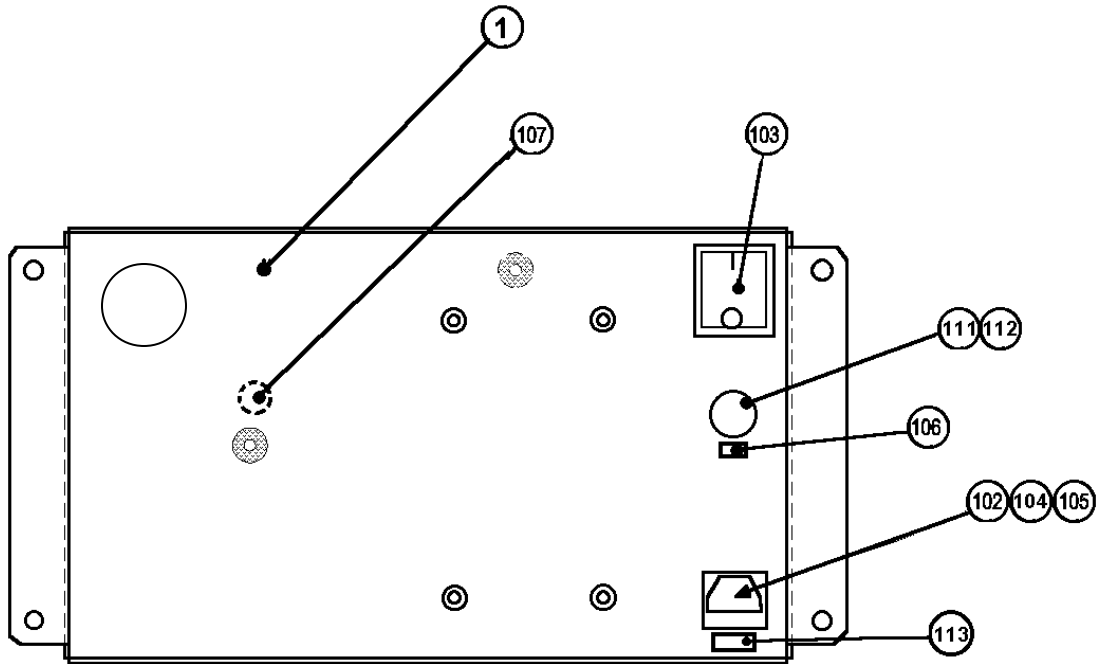

ITEM	PART NO.	QTY	DESCRIPTION	COMPONENT REF.
1	ORT-0401UK	1	AC BRKT UK	
106	421-6595-5000-T	1	STICKER FUSE 5000mA TYPE T	FUSE HOLDER
107	LB1096	1	STICKER PROTECTIVE EARTH	EARTH POINT INSIDE
111	EP1334	1	FUSE HOLDER 20mm 10A 240Vac	
112	514-5078-5000	1	FUSE 5X20 CERAMIC SB 5000mA	
114	360168	1	SNAP-BUSHING-HEYCO-400 2182	
204	050-F00400	3	M4 NUT FLG SER PAS	(INSIDE EARTH)-2,(OUTSIDE)-1
303	600-9030-44K	1	WIRE HARN EARTH 300mm M4/M4 K	AC BRKT TO MAIN BASE
304	600-9040-45K	1	WIRE HARN EARTH 400mm M4/M5 K	AC BRKT - XFMR
305	600-6999-201UK	1	WIRE HARN SUB AC BRKT	

8.24. ORT-4560UK ASSY LAN COM2

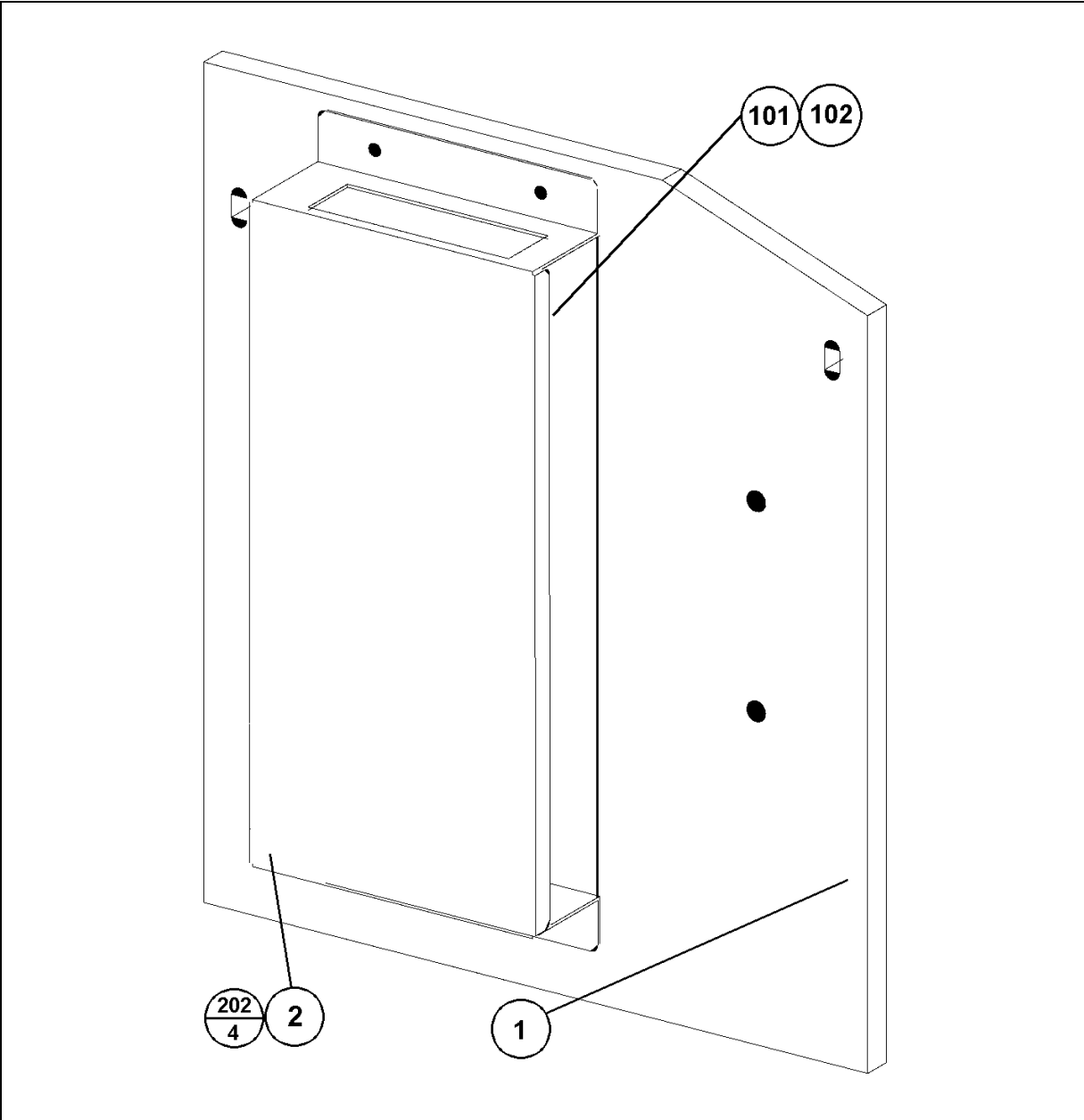

ITEM	PART NO.	QTY	DESCRIPTION	COMPONENT REF.
1	ORT-4561UK	1	WOODEN BASE DRIVE TWIN	
2	ORT-1005	1	HUB HOLDER	
3	VOF-1001	1	BASE HOLDER BRKT	
101	601-11351	1	SW HUB MELCO LSW10/100-8HW	LEFT UNIT
102	290190	24	TAPE-FOAM-20MM X 4.50MM	-101
201	050-F00400	2	M4 NUT FLG SER PAS	(3)-2
202	012-P03512-F	4	N6X1/2" S/TAP FLG PAS	(2)-4
301	600-7269-0200	1	ASSY LAN CABLE 0200CM	

9. APPENDIX A - ELECTRICAL SCHEMATIC

9.1. Wire Colours

THE WIRE COLOUR CODE IS AS FOLLOWS:

A	PINK
B	SKY BLUE
C	BROWN
D	PURPLE
E	LIGHT GREEN

Wires other than those of any of the colours listed above will be displayed by 2 alphanumeric characters:

1	RED
2	BLUE
3	YELLOW
4	GREEN
5	WHITE
7	ORANGE
8	BLACK
9	GREY

If the right hand side numeral of the code is 0, then the wire will be of a single colour shown by the left hand side numeral (see the list above).

Note 1: If the right hand side alphanumeric is not 0, that particular wire has a spiral colour code. The left hand side character shows the base colour and the right hand side one, the spiral colour.

[Example] 51 ----- WHITE/RED = WHITE wire with RED stripes

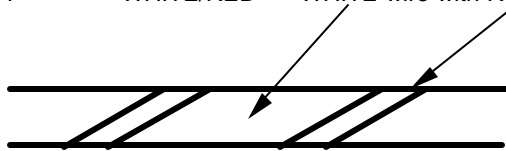

Note 2: The character following the wire colour code indicates the size of the wire.

K:	AWG18, UL1015
L:	AWG20, UL1007
None	AWG22, UL1007

9.2. Electrical Schematic

The following pages contain the electrical schematic for this machine.

Schematic 1 here

Schematic 2 here

Schematic 3 here