

SEGA™

SCUD RACE

TWIN TYPE

OWNER'S MANUAL

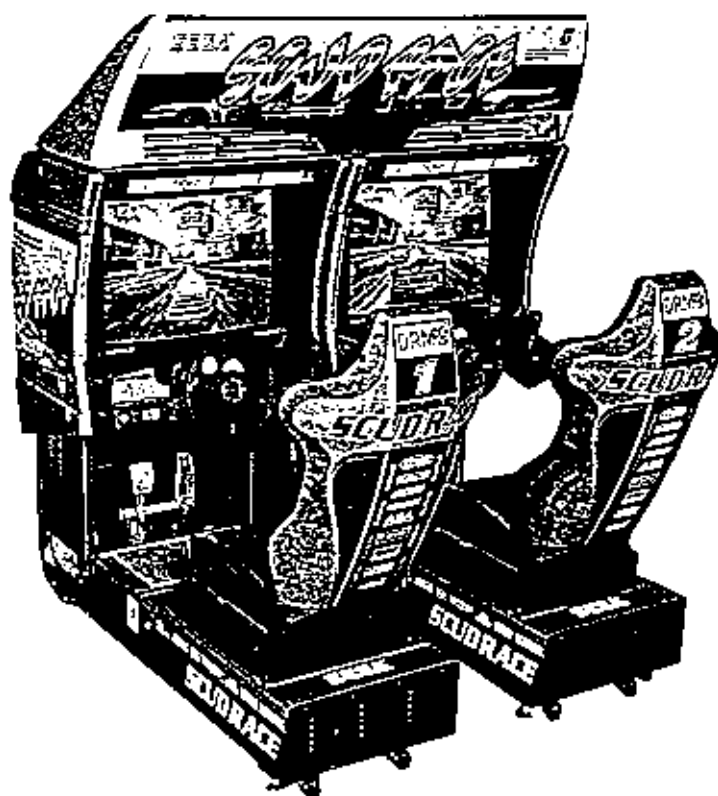

IMPORTANT!

- Before using this product, read this SERVICEMAN MANUAL carefully to understand the contents herein stated.
- After reading this manual, be sure to keep it available nearby the product or elsewhere convenient for referring to it anytime when necessary.

SEGA ENTERPRISES, LTD.

MANUAL NO. 420 - 6289 - 01



BEFORE USING THE PRODUCT, BE SURE TO READ THE FOLLOWING.

To maintain the safety:

To ensure the safe usage of the product, be sure to read the following before using the product. The following instructions are intended for the users, operators and the personnel in charge of the operation of the product. After carefully reading and sufficiently understanding the warning displays and cautions, handle the product appropriately. Be sure to keep this manual nearby the product or elsewhere convenient for referring to it when necessary.

Herein, explanations which require special attention are enclosed with dual lines. Depending on the potentially hazardous degrees, the terms of **WARNING!**, **CAUTION!** and **IMPORTANT!** are used. Be sure to understand the contents of the displays before reading the text.



WARNING!

Indicates that mishandling the product by disregarding this warning will cause a potentially hazardous situation which can result in death or serious injury.



CAUTION!

Indicates that mishandling the product by disregarding this caution will cause a potentially hazardous situation which can result in personal injury and or material damage.



IMPORTANT!

Indicates that mishandling the product by disregarding this display can cause the product's intrinsic performance not to be obtained, resulting in malfunctioning.

For the safe usage of the product, the following symbol marks are used:



Indicates "HANDLE WITH CARE." In order to protect the human body and equipment, this display is attached to places where the Owner's Manual and or Service Manual should be referred to.



Indicates a "Protective Earth Terminal." Before operating the equipment, be sure to connect it to the Ground.

- **Be sure to turn off power before working on the machine.**
To prevent electric shock, be sure to turn off power before starting the work in which the worker touches the interior of the product. If the work is to be performed in the power-on status, the Instruction Manual herein always states to that effect.
- **Be sure to ground the Earth Terminal (this, however, is not required in the case where a power cord with earth is used).**
This product is equipped with the Earth Terminal. When installing the product, Connect the Earth Terminal to the "accurately grounded indoor earth terminal" by using an earth wire. Unless the product is grounded appropriately, the user can be subject to electric shock. After performing repair, etc. for the Control equipment, ensure that the Earth Wire is firmly connected to the Control equipment.
- **Ensure that the Power Supply used is equipped with an Earth Leakage Breaker.**
This product does not incorporate the Earth Leakage Breaker. Using a power supply which is not equipped with the Earth Leakage Breaker can cause a fire when earth leakage occurs.
- **Be sure to use fuses which meet the specified rating.**
Using fuses exceeding the specified rating can cause a fire and electric shock.

- **Specification changes (removal of equipment, conversion and addition) not designated by SEGA are not allowed.**
The parts of the product include warning labels for safety, covers for personal protection, etc. It is very hazardous to operate the product by removing parts and or modifying the circuits. Should doors, lids and protective parts be damaged or lost, refrain from operating the product, and contact the distributor, etc. where the product was purchased from.
 - **Ensure that the product meets the requirements of appropriate Electrical Specifications.**
Before installing the product, check for Electrical Specifications. SEGA products have a nameplate on which Electrical Specifications are described. Ensure that the product is compatible with the power supply voltage and frequency requirements of the location. Using any Electrical Specifications different from the designated Specifications can cause a fire and electric shock.
 - **Install and operate the product in places where appropriate lighting is available, allowing warning labels to be clearly read.**
To ensure safety for the customers, labels and printed instructions describing potentially hazardous situation are applied to places where accidents can be caused. Ensure that where the product is operated has sufficient lighting allowing the warnings to be read. If any label is peeled off, apply it again immediately.
 - **When handling the Monitor, be very careful. (Applies only to the product w/monitor).**
Some of the monitor (TV) parts are subject to high tension voltage. Even after turning off power, some portions are still subject to high tension voltage sometimes. Monitor, repair and replacement should be performed only by those technical personnel who have knowledge of electricity and technical expertise.

In the case where commercially available monitors and printers are used in this product, only the contents relating to this product are explained herein. Some commercially available equipment has functions and reactions not stated in this manual. Read this manual together with the specific Instruction Manual of such equipment.
- Descriptions herein contained may be subject to improvement changes without notice.
 - The contents described herein are fully prepared with due care. However, should any question arise or errors be found, please contact SEGA.

INSPECTIONS IMMEDIATELY AFTER TRANSPORTING THE PRODUCT TO THE LOCATION.

Normally, at the time of shipment, SEGA products are in a status allowing for usage immediately after transporting to the location. Nevertheless, an irregular situation may occur during transportation. Before turning on power, check the following points to ensure that the product has been transported in a satisfactory status.

- Are there any dented portions or defects (cuts, etc.) on the external surfaces of the cabinet?
- Are Casters and Leg Adjusters damaged?
- Do the power supply voltage and frequency requirements meet with those of the location?
- Are all wiring connectors correctly and securely connected? Unless connected in the correct direction, connector connections can not be made accurately. Do not insert connectors forcibly.
- Are all IC's of each IC BD firmly inserted?
- Do power cords have cuts and dents?
- Do the fuses used meet specified rating? Is the Circuit Protector in an energized status?
- Are such units as Monitors, Control equipment, IC BD, etc. firmly secured? Are all Earth Wires connected?
- Are all accessories available?
- Can all Doors and Lids be opened with the Accessory keys? Can Doors and Lids be firmly closed?

TABLE OF CONTENTS

BEFORE USING THE PRODUCT, BE SURE TO READ THE FOLLOWING :

TABLE OF CONTENTS

INTRODUCTION OF THE OWNER'S MANUAL

1. HANDLING PRECAUTIONS	1 ~ 2
2. PRECAUTIONS CONCERNING INSTALLATION LOCATION.....	3 ~ 4
3. OPERATION	5 ~ 6
4. NAME OF PARTS	7
5. ACCESSORIES	8
6. ASSEMBLING AND PRECAUTIONS	9~18
7. PRECAUTIONS TO BE HEEDED WHEN MOVING THE MACHINE	19
8. CONTENTS OF GAME	20~22
9. EXPLANATION OF TEST AND DATA DISPLAY	23~41
9-1 SWITCH UNIT AND COIN METER	24
9-2 TEST MODE	25
9-3 MEMORY TEST	26~27
9-4 BOUNDARY SCAN TEST	28
9-5 INPUT TEST	29
9-6 OUTPUT TEST	30
9-7 SOUND TEST	31
9-8 C.R.T. TEST	32
9-9 DRIVE BOARD TEST	33~34
9-10 GAME ASSIGNMENTS	35
9-11 COIN ASSIGNMENT	36~39
9-12 BOOKKEEPING	40
9-13 BACKUP DATA CLEAR	41
10. HANDLE MECHA	42~44
10-1 REMOVING THE CONTROL PANEL	42
10-2 REPLACING AND ADJUSTING THE HANDLE'S (STEERING WHEEL'S) V. R.	43
10-3 GREASING	44
11. ACCELERATOR & BRAKE	45~46
11-1 ADJUSTING AND REPLACING THE V. R.	45~46
11-2 GREASING	46
12. SHIFT LEVER	47~48
12-1 REMOVING THE SHIFT LEVER	47
12-2 SWITCH REPLACEMENT	48
13. COIN SELECTOR	49
14. MONITOR ADJUSTMENTS	50~53
14-1 CAUTIONS AND WARNINGS CONCERNING THE SAFETY FOR HANDLING THE MONITORS	50~51
14-2 CAUTIONS TO BE HEEDED WHEN CLEANING THE CRT SURFACES	51
14-3 ADJUSTMENT METHOD	52~53
15. REPLACING THE FLUORESCENT LAMP	54~55
15-1 REPLACING THE FLUORESCENT LAMP	54
15-2 REPLACING THE LEADER LAMP	55
16. PERIODIC INSPECTION TABLE	56~57
17. TROUBLESHOOTING	57~59
18. GAME BOARD	60~64
18-1 REMOVING THE BOARD	60
18-2 COMPOSITION OF GAME BOARD	61
18-3 ERROR DISPLAY (DRIVE CONTROL BOARD)	62~63
18-4 DIP SW SETTING	64
19. DESIGN RELATED PARTS	65~66
20. COMMUNICATION PLAY	67~71
20-1 INSTALLATION PRECAUTIONS	67
20-2 CONNECTING THE COMMUNICATION CABLES	67~70
20-3 SETTING FOR COMMUNICATION PLAY	71
20-4 CAUTIONS TO BE HEEDED WHEN USING THE TEST MODE	71
21. PARTS LIST	72~127
22. WIRE COLOR CODE TABLE	128
23. WIRING DIAGRAM	129~134

SPECIFICATIONS

Installation space	: 1,632 mm (W) × 1,700 mm (D) (64.3 in. × 66.9 in.)
Height	: 1,935 mm (76.2 in.)
Weight	: Approx. 507 kg. (1,118 lbs.)
Power, maximum current	: 703W 8.20A (AC 110V 50 Hz AREA) 696W 8.10A (AC 110V 60 Hz AREA) 683W 7.20A (AC 120V 60 Hz AREA) 758W 4.40A (AC 220V 50 Hz AREA) 693W 4.00A (AC 220V 60 Hz AREA) 745W 4.00A (AC 240V 50 Hz AREA) 689W 3.70A (AC 240V 60 Hz AREA)
For TAIWAN	
Power, current	: 720W 8.40A(MAX.) 550W 6.30A(MIN.)
MONITOR	: 29 INCH COLOR MONITOR × 2

INTRODUCTION OF THE OWNER'S MANUAL

SEGA ENTERPRISES, LTD., supported by its high electronic technology of LSIs, microprocessors, etc. and a wealth of experience, has for more than 30 years been supplying various innovative and popular game machines to the world market. This Owner's Manual is intended to provide detailed descriptions together with all the necessary information covering the general operation of electronic assemblies, electromechanicals, servicing control, spare parts, etc. as regards SCUD RACE TWIN TYPE, a new SEGA product.

This manual is intended for those who have knowledge of electricity and technical expertise especially in ICs, CRTs, microprocessors, etc. Carefully read this manual to acquire sufficient knowledge before working on the machine. Should there be a malfunction, non-technical personnel should under no circumstances touch the interior system. Should such a case arise, contact our Main Office or the closest branch office listed as follows:

SEGA ENTERPRISES, INC. (U.S.A.)/CUSTOMER SERVICE
45133 Industrial Drive, Fremont, California 94538, U.S.A.
Phone : (415) 802-3100
Fax : (415) 802-1754

DEFINITION OF LOCATION MAINTENANCE MAN AND SERVICEMAN



Non-technical personnel who do not have technical knowledge and expertise should refrain from performing such work that this manual requires the location's maintenance man or a serviceman to carry out, or work which is not explained in this manual. Failing to comply with this instruction can cause a severe accident such as electric shock.

Ensure that parts replacement, servicing & inspections, and troubleshooting are performed by the location's maintenance man or the serviceman. It is instructed herein that particularly hazardous work should be performed by the serviceman who has technical expertise and knowledge.

The location's maintenance man and serviceman are herein defined as follows:

"Location's Maintenance Man" :

Those who have experience in the maintenance of amusement equipment and vending machines, etc., and also participate in the servicing and control of the equipment through such routine work as equipment assembly and installation, servicing and inspections, replacement of units and consumables, etc. within the Amusement Facilities and or locations under the management of the Owner and Owner's Operators of the product.

Activities of Location's Maintenance Man :

Assembly & installation, servicing & inspections, and replacement of units & consumables as regards amusement equipment, vending machines, etc.

Serviceman :

Those who participate in the designing, manufacturing, inspections and maintenance service of the equipment at an amusement equipment manufacturer.

Those who have technical expertise equivalent to that of technical high school graduates as regards electricity, electronics and or mechanical engineering, and daily take part in the servicing & control and repair of amusement equipment.

Serviceman's Activities :

Assembly & installation and repair & adjustments of electrical, electronic and mechanical parts of amusement equipment and vending machines.

1. HANDLING PRECAUTIONS

When installing or inspecting the machine, be very careful of the following points and pay attention to ensure that the player can enjoy the game safely.

Non-compliance with the following points or inappropriate handling running counter to the cautionary matters herein stated can cause personal injury or damage to the machine.



- Before performing the work, be sure to turn power off. Performing the work without turning power off can cause an electric shock or short circuit.
- To avoid electric shock or short circuit, do not insert or pull out the plug quickly.
- To avoid electric shock, do not unplug with a wet hand.
- Do not expose Power Cords and Earth Wires on the surface, (floor, passage, etc.). If exposed, the Power Cords and Earth Wires are susceptible to damage. Damaged cords and wires can cause electric shock or short circuit.
- To avoid causing a fire or electric shock, do not put things on or damage Power Cords.
- When or after installing the product, do not unnecessarily pull the power cord. If damaged, the power cord can cause a fire or electric shock.
- In case the power cord is damaged, ask for replacement through where the product was purchased from or the office herein stated. Using the cord as is damaged can cause fire, electric shock or leakage.
- Be sure to perform grounding appropriately. Inappropriate grounding can cause an electric shock.
- Be sure to use fuses meeting specified rating. Using fuses exceeding the specified rating can cause a fire or electric shock.
- Completely make connector connections for IC BD and others. Insufficient insertion can cause an electric shock.
- To avoid causing a fire or electric shock, do not make Specification changes by removing, converting and making additions unless otherwise designated by SEGA.
- Be sure to perform periodic maintenance inspections herein stated.



- Also, for the IC board circuit inspections, only the logic tester is allowed. The use of a multiple-purpose tester is not permitted, so be careful in this regard.
- When cleaning the CRT surfaces, use a soft, dry cloth. Do not apply chemicals such as thinner, benzine, etc.
- When you touch the monitor (CRT) at the time the power is turned on or off, you might slightly feel electricity. This, however, is caused by static electricity and would not adversely affect the human body.

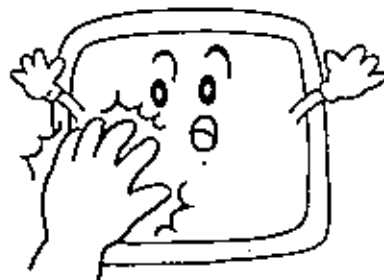

CONCERNING THE STICKER DISPLAY

SEGA product has Stickers describing the product manufacture No. (Serial No.) and Electrical Specifications. Also it has a Sticker describing where to contact for repair and for purchasing parts. When inquiring about or asking for repair, mention the Serial No. and Name of Machine indicated on the Sticker. The Serial No. indicates the product register. Identical machines could have different parts depending on the date of production. Also, improvements and modifications might have been made after the publication of this Manual. In order to meet the above situations, mention the Serial No. when contacting the applicable places.

CONCERNING WARNING DISPLAYS

SEGA product has warning displays on Stickers, Labels and or printed instructions adhered / attached to or incorporated in the places where a potentially hazardous situation can arise. The warning displays are intended for accident prevention for the customers and for avoiding hazardous situation relating to maintenance and servicing work. There are some portions in the Cabinet, which are subject to high tension voltage, etc. where accidents can be caused only by touching. When performing the servicing work, be very careful of the warning displays. Especially, any complex repair and replacement work not mentioned herein, should be performed by those technical personnel who have knowledge of electricity and technical expertise. For the prevention of accidents, caution any customer whose act runs counter to the warnings, as to the effect that he must stop the act.

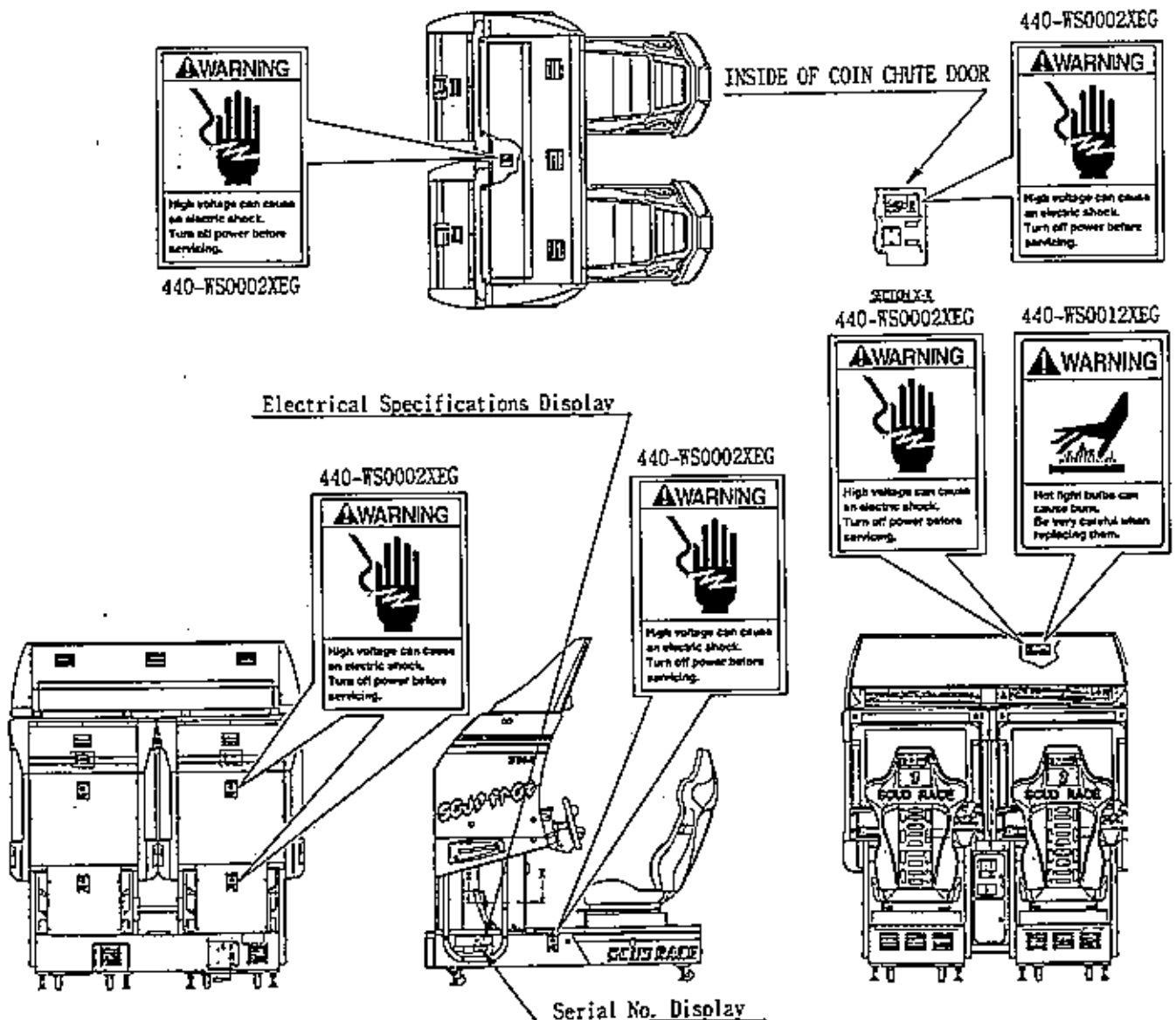

2. PRECAUTIONS CONCERNING INSTALLATION LOCATION



WARNING!

This product is an indoor game machine. Do not install it outside. Even indoors, avoid installing in places mentioned below so as not to cause a fire, electric shock, injury and or malfunctioning.

- Places subject to rain or water leakage, or places subject to high humidity in the proximity of an indoor swimming pool and or shower, etc.
- Places subject to direct sunlight, or places subject to high temperatures in the proximity of heating units, etc.
- Places filled with inflammable gas or vicinity of highly inflammable/volatile chemicals or hazardous matter.
- Dusty places.
- Sloped surfaces
- Places subject to any type of violent impact.
- Vicinity of anti-disaster facilities such as fire exits and fire extinguishers.
- The operating (ambient) temperature range is from 5°C to 40°C. Only in the case a projector is employed, the temperature range is from 5°C to 30°C.

LIMITATIONS OF USAGE REQUIREMENTS



WARNING!

- Be sure to check the Electrical Specifications. Ensure that this product is compatible with the location's power supply, voltage and frequency requirements. A plate describing Electrical Specifications is attached to the product. Non-compliance with the Electric Specifications can cause a fire and electric shock.
- This product requires the Breaker and Earth Mechanisms as part of the location facilities. Using them in a manner not independent can cause a fire and electric shock.
- Ensure that the indoor wiring for the power supply is rated at 10A or higher (AC single phase 100~120V area), and 5A or higher (AC 220~240V area). Non-compliance with the Electrical Specifications can cause a fire and electric shock.
- Be sure to independently use the power supply equipped with the Earth Leakage Breaker. Using a power supply without the Earth Leakage Breaker can cause an outbreak of fire when earth leakage occurs.
- Putting many loads on one electrical outlet can cause generation of heat and a fire resulting from overload.
- When using an extension cord, ensure that the cord is rated at 15A or higher (AC 100~120V area) and 7A or higher (AC 220~240V area). Using a cord rated lower than the specified rating can cause a fire and electric shock.



IMPORTANT!

- Note that for transporting the machine into the location's building, the minimum necessary dimensions of the opening (of doors, etc.) are 0.85m(W) and 1.55m(H).
- For the operation of this machine, secure a minimum area of 2.2m (W) x 2.3m (D). For ventilation, provide an approximately 20cm. space between the rear part of the cabinet and the wall.

Electric current consumption

MAX.	8.20A	(AC 110V	50 Hz)
MAX.	8.10A	(AC 110V	60 Hz)
MAX.	7.20A	(AC 120V	60 Hz)
MAX.	4.40A	(AC 220V	50 Hz)
MAX.	4.00A	(AC 220V	60 Hz)
MAX.	4.00A	(AC 240V	50 Hz)
MAX.	3.70A	(AC 240V	60 Hz)
MAX.	8.40A	(For TAIWAN)	

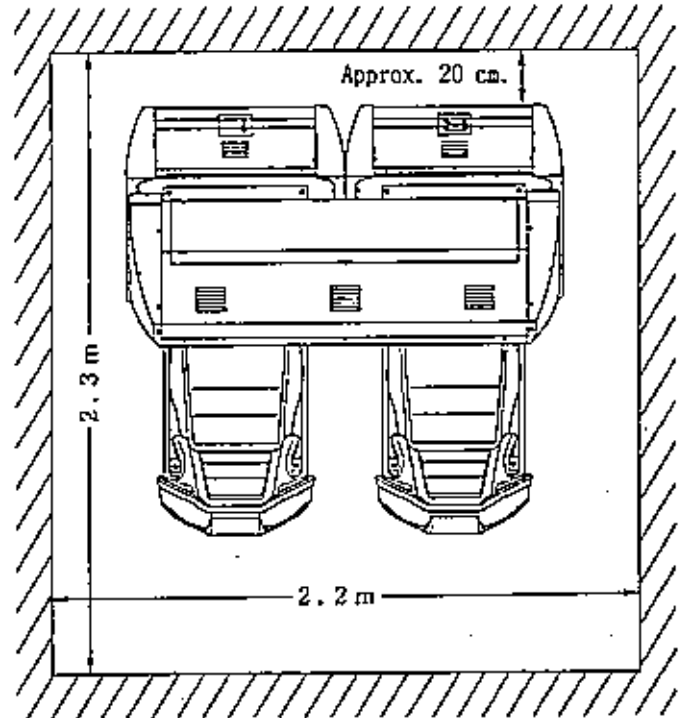

FIG. 2

3. OPERATION

PRECAUTIONS TO BE HEEDED (BY CUSTOMERS) DURING OPERATION

To avoid injury and trouble, be sure to constantly give careful attention to the behavior and manner of the visitors and players.



In order to avoid accidents, check the following before starting the operation:

- Check if all of the adjusters are in contact with the surface. If they are not, the Cabinet can move and cause an accident.

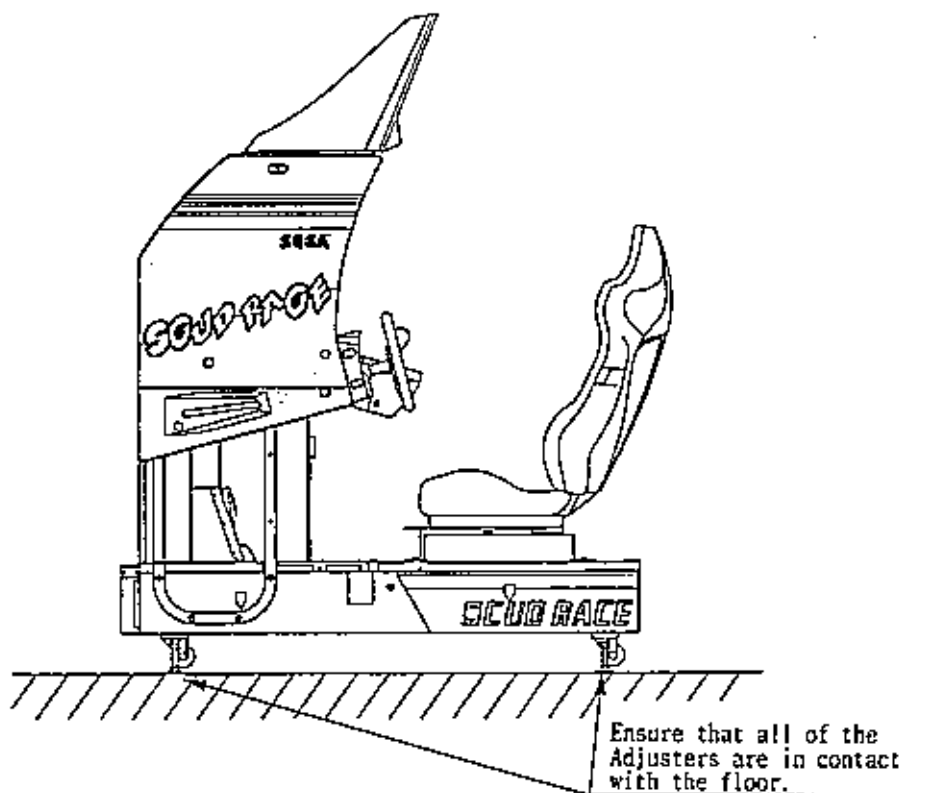

- Do not put any heavy item on this product. Placing any heavy item on the product can cause a falling down accident or parts damage.
- Do not climb on the product. Climbing on the product can cause falling down accidents. To check the top portion of the product, use a step.
- To avoid electric shock, short circuit and or parts damage, do not put the following items on or in the periphery of the product.
Flower vases, flowerpots, cups, water tanks, cosmetics, and receptacles/containers/vessels containing chemicals and water.



To avoid injury, be sure to provide sufficient space by considering the potentially crowded situation at the installation location. Insufficient installation space can cause the player to come into contact with or hit the others and result in injury or trouble.

PAYING ATTENTION TO CUSTOMERS

To avoid injury and trouble, be sure to constantly give careful attention to the behavior and manner of the visitors and players.



- To avoid electric shock and short circuit, do not allow customers to put hands and fingers or extraneous matter in the openings of the product or small openings in or around the doors.
- To avoid falling down and injury resulting from falling down, immediately stop the customer's leaning against or climbing on the product, etc.
- To avoid electric shock and short circuit, do not allow the customers to unplug the power plug without a justifiable reason.
- To avoid injury resulting from falling down, and electric shock due to spilled drinks, instruct the player not to place heavy items or drinks on the product.



Immediately stop such violent acts as hitting and kicking the product. Such violent acts can cause parts damage or falling down, resulting in injury due to fragments and falling down.

4. NAME OF PARTS

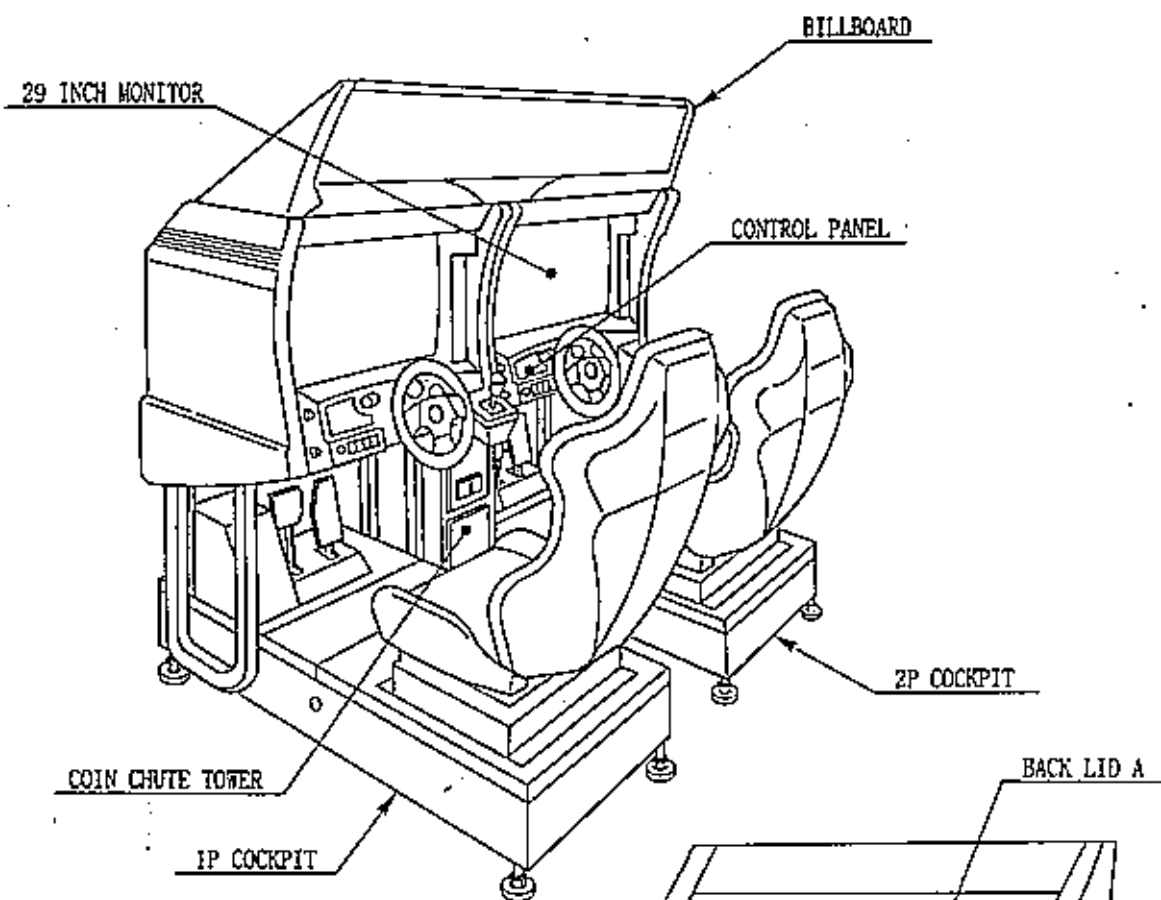

FIG. 4.1 OVERVIEW

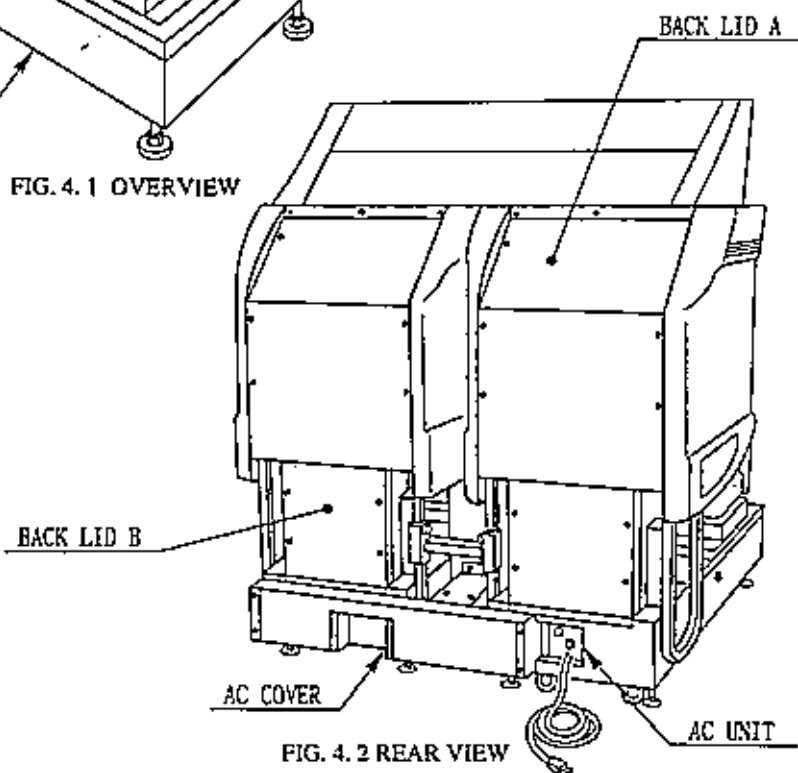

FIG. 4.2 REAR VIEW

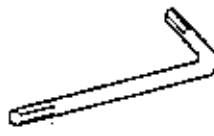
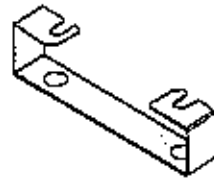
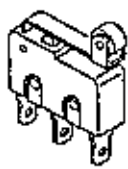
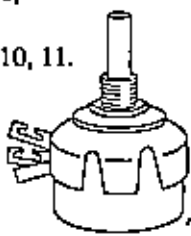
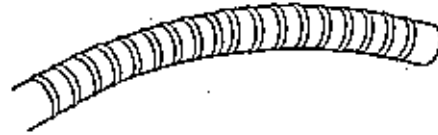
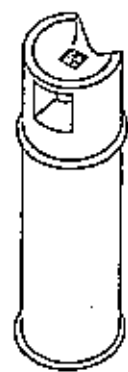

TABLE 4

	Width		Length		Height (mm.)	Weight (kg.)
COCKPIT (per seat)	820	×	1,645	×	1,520	228
COIN CHUTE TOWER	305	×	515	×	570	15
BILLBOARD	1,608	×	568	×	420	31
When assembled	1,632	×	1,700	×	1,935	507

5. ACCESSORIES

When transporting the machine, make sure that the following parts are supplied.

TABLE 5 ACCESSORIES

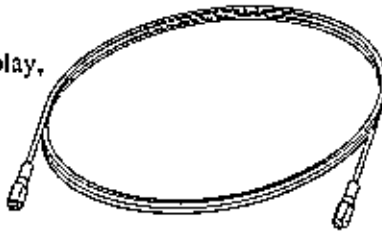
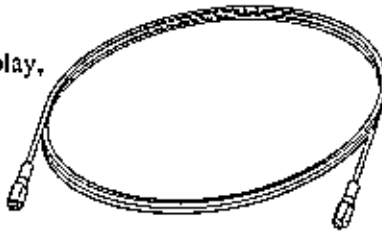
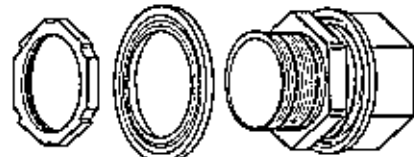
<p>DESCRIPTION Part No. (Qty.) Note Figures If Part No. has no description, the Number has not been registered or can not be registered. Such a part may not be obtainable even if the customer desires to purchase it. Therefore, ensure that the part is in safekeeping with you.</p>	<p>OWNERS MANUAL 420-6289-01 (1)</p>	<p>KEY MASTER 220-5576 (2) For opening/closing the doors</p>	<p>KEY (2) For the CASHBOX DOOR</p>
<p>FUSE 7000mA 125V 514-5036-7000 (2) For spare, refer to Section 17.</p> 	<p>(TAMPERPROOF WRENCH) M8 540-0009-01 (1) TOOL</p> 	<p>JOINT PLATE DYN-0020 (1) Used for installation, refer to Section 6.</p> 	
<p>SW MICRO TYPE 509-5636 (3) For spare, refer to Section 12.</p>  <p>VOL CONT B-5K OHM 220-5373 (1) 220-5484 (1) For spare, refer to Section 10, 11.</p> 	<p>FLEX TUBE 310-5050-220090 (1) For communication play, refer to Section 20.</p> 	<p>STATICIDE (300ML) 090-0074 (1) Articles of consumption see below.</p>  <p>Periodically once every two months as standard, apply the "STATICIDE" (an antistatic spray agent) to the SEATs and wipe with a dry cloth.</p>	
<p>STICKER STC CAR NO. 2~8 421-9464 (1) For communications play, refer to Section 20.</p> 		<p>CONN 22 310-5051-22 (2) For communications play, refer to Section 20.</p> 	
<p>ASSY FIBER CABLE 600-6275-0500 (2) For communications play, refer to Section 20.</p> 		<p>CONN 22 310-5051-22 (2) For communications play, refer to Section 20.</p> 	

6. ASSEMBLING AND PRECAUTIONS



- Perform the assembly work by following the procedure herein stated. Failing to comply with the instructions, for example, inserting the plug into an outlet at the stage not mentioned in this manual can cause an electric shock.
- Assembling should be performed as per this manual. Since this is a complex machine, erroneous assembling can cause damage to the machine, or malfunctioning to occur.
- When assembling, be sure to perform the work by plural persons. Depending on the assembly work, there are some cases in which performing the work by a single person can cause personal injury or parts damage.

When carrying out the assembly work, follow the procedure in the following 7-item sequence:

- 1 ASSEMBLING THE COCKPIT
- 2 SECURING IN PLACE (ADJUSTER ADJUSTMENT)
- 3 INSTALLING THE BILLBOARD
- 4 INSTALLING THE AC COVERS (WIRING CONNECTION)
- 5 POWER SUPPLY, AND EARTH CONNECTION
- 6 TURNING THE POWER ON
- 7 ASSEMBLY CHECK

Note that the master key and the cashbox door key (accessories) in addition to the tools such as a Phillips type plus screwdriver, wrench for M16 hexagon bolt and socket wrench are required for the assembly work.



Perform the tightening of hexagon bolts described in 1 above after adjusting the adjusters as per 2. Make sure that until the adjuster adjustments are made, keep the hexagon bolts tightened temporarily.

1 ASSEMBLING THE COCKPIT

- ① Place the two cockpits side by side. Position the 1P cabinet which has the power cord at the left-hand side as viewed facing the monitor. STICKER "L" is attached on the back of 1P cabinet, and STICKER "R" on the back of 2P cabinet (Fig. 6.1a).

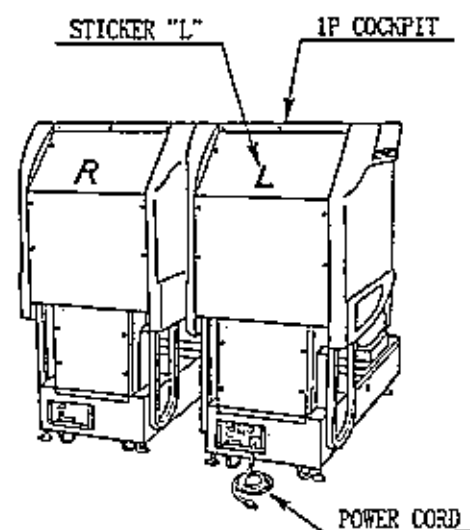

FIG. 6.1a

- ② Install the coin chute tower in between both cabinets. Open the coin chute door and the cashbox door to secure with the 4 hexagon bolts from inside the doors. At this time, make sure that the bolts are fastened temporarily (Fig. 6.1b).

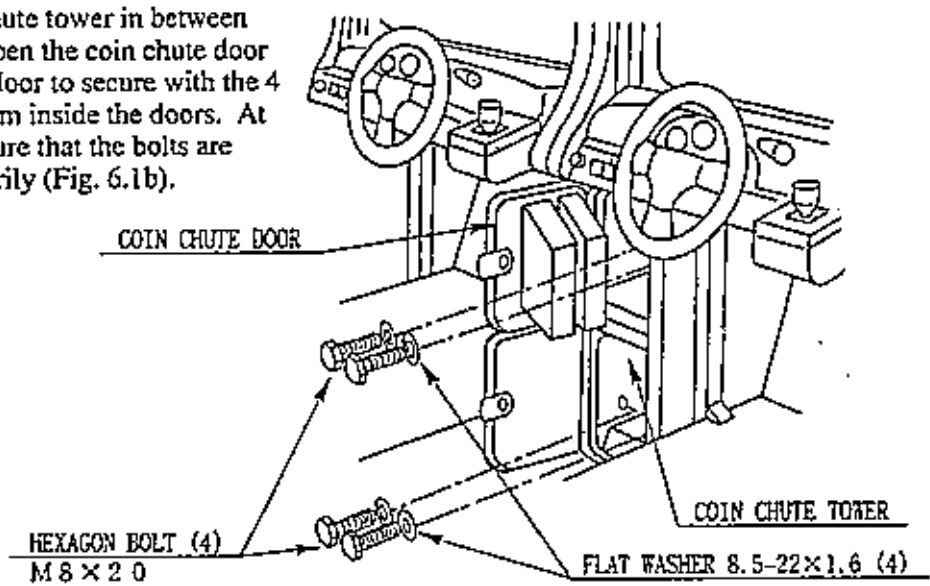

FIG. 6.1 b

- ③ Install the joint pipe on to the backside of both cabinets by securing with 4 hexagon bolts (at this time, temporarily) (Fig.6.1c)

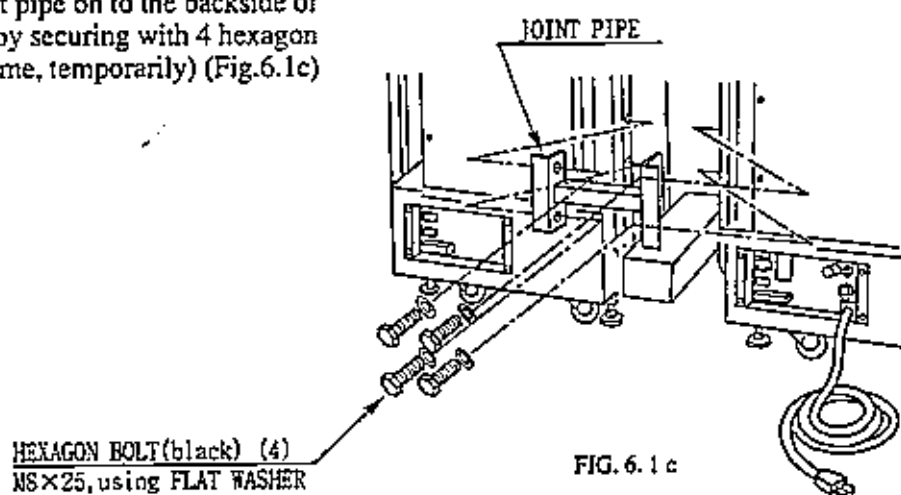

FIG. 6.1 c

- ④ Attach the blind cap to the head of each hexagon bolt (6 bolts on each side of the monitor ... a total of 12) by pressing it in.

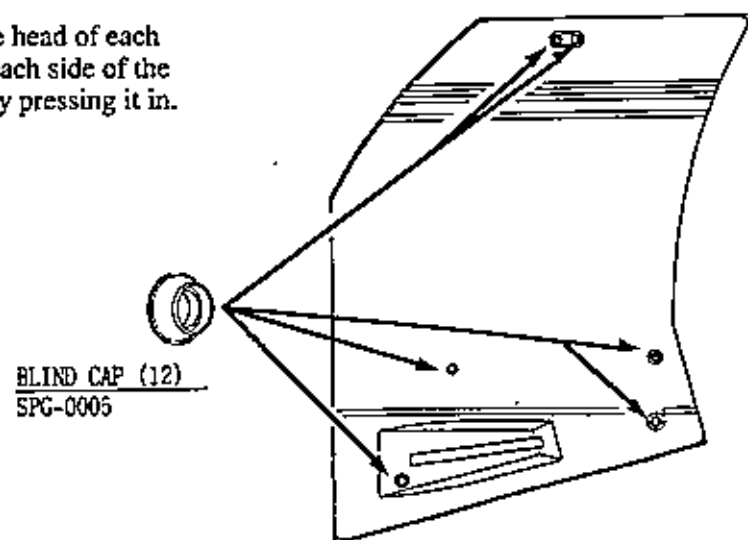

FIG. 6.1 d

2 SECURING IN PLACE (ADJUSTER ADJUSTMENT)



- Make sure that all of the adjusters are in contact with the floor. If they are not, the cabinet may move and cause an accident.
- When assembling, be sure to perform the work by plural persons. Depending on the assembly work, there are some cases in which performing the work by a single person can cause personal injury or parts damage.

This machine has eight casters and eight adjusters (Fig. 6.2a). When the installation position is determined, cause the adjusters to come into contact with the floor directly, make adjustments in a manner so that the casters will be raised approximately 5mm. from the floor and make sure that the machine position is level.

- ① Move the machine to the installation position. When installing the machine against or close to a wall, be sure to secure a passage space to enable the player to take a ride in the machine.
- ② Attach the joint plate for the 2 internal adjusters shown. First, cause the other 6 adjusters to come into contact with the floor. Make adjuster adjustments with a wrench in a manner to ensure the machine's position is level (Fig.6.2b).
- ③ After making adjustments, fasten the adjuster nut upward and secure the height of the adjuster (Fig.6.2b).

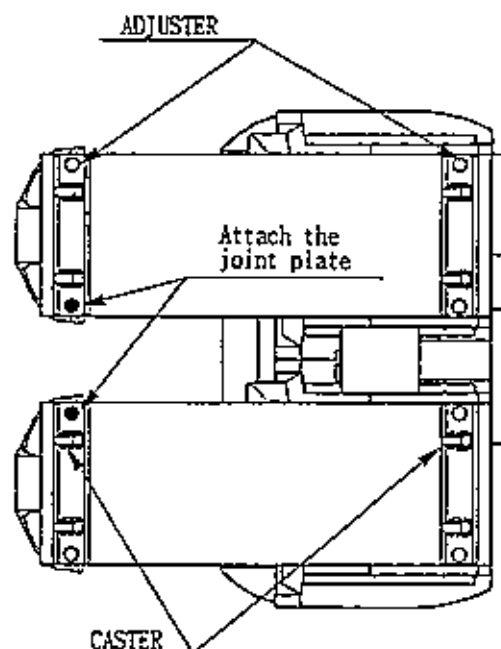

FIG. 6.2 a BOTTOM VIEW

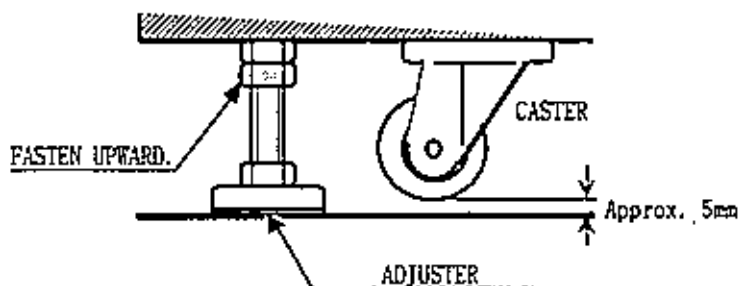
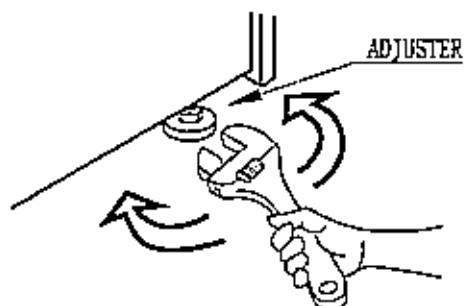

FIG. 6.2 b ADJUSTER

- ④ Insert the notch portions of the joint plate to the 2 adjuster bolt portions.
- ⑤ Lower the adjuster and fasten the nut upward. Secure the joint plate with the nuts and the bottoms of the adjuster (Fig.6.2c).

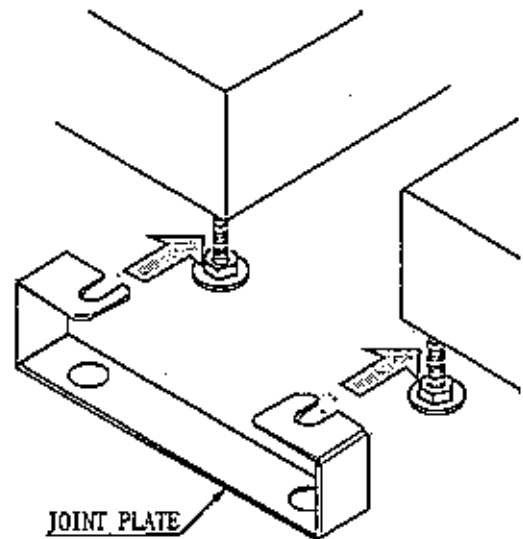
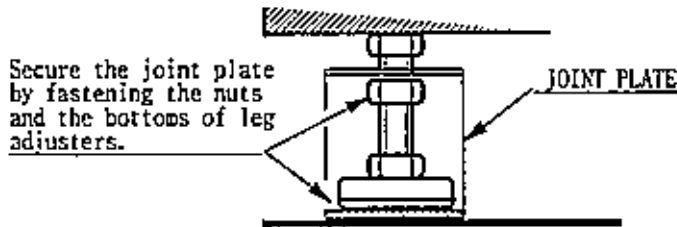

FIG. 6. 2 c JOINT PLATE

After securing the height of the adjusters, tighten all of the hexagon bolts which were fastened temporarily as per **1** above.

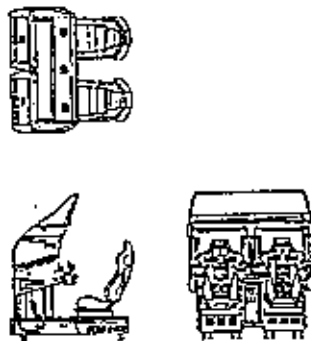

FIG. 6. 2 d
Refer to this Fig. (Scale:1/100)
for the layout of the place of
installation.

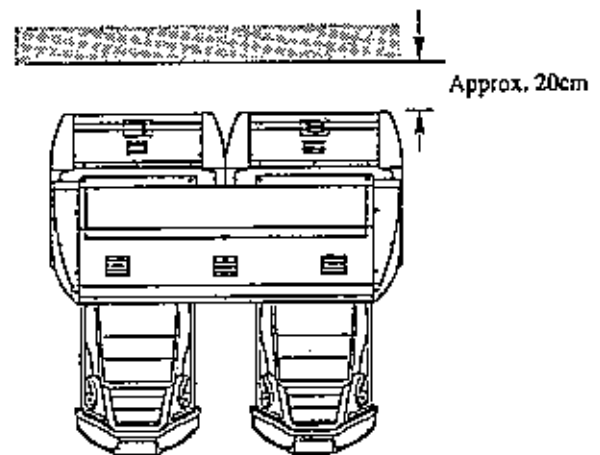

FIG. 6. 2 c
Provide sufficient space so as to
allow for ventilation by the ven-
tilation fan.

3

INSTALLING THE BILLBOARD



It is difficult for one person to perform the billboard installation. Make sure that the work is carried out by plural persons. Performing the work by one person alone can cause an accident.

- ① Remove the 3 Truss Screws to open the Lid.
- ② Mount the Billboard on both cabinets and secure with the 4 hexagon bolts for each cabinet.
- ③ Connect all of the 3 Connectors inside the Billboard Box.
- ④ Install 2 Billboard Holders to the rear side of the Billboard Box and secure with 4 hexagon bolts for each holder.
- ⑤ Close the Lid and secure with the 3 Truss Screws.

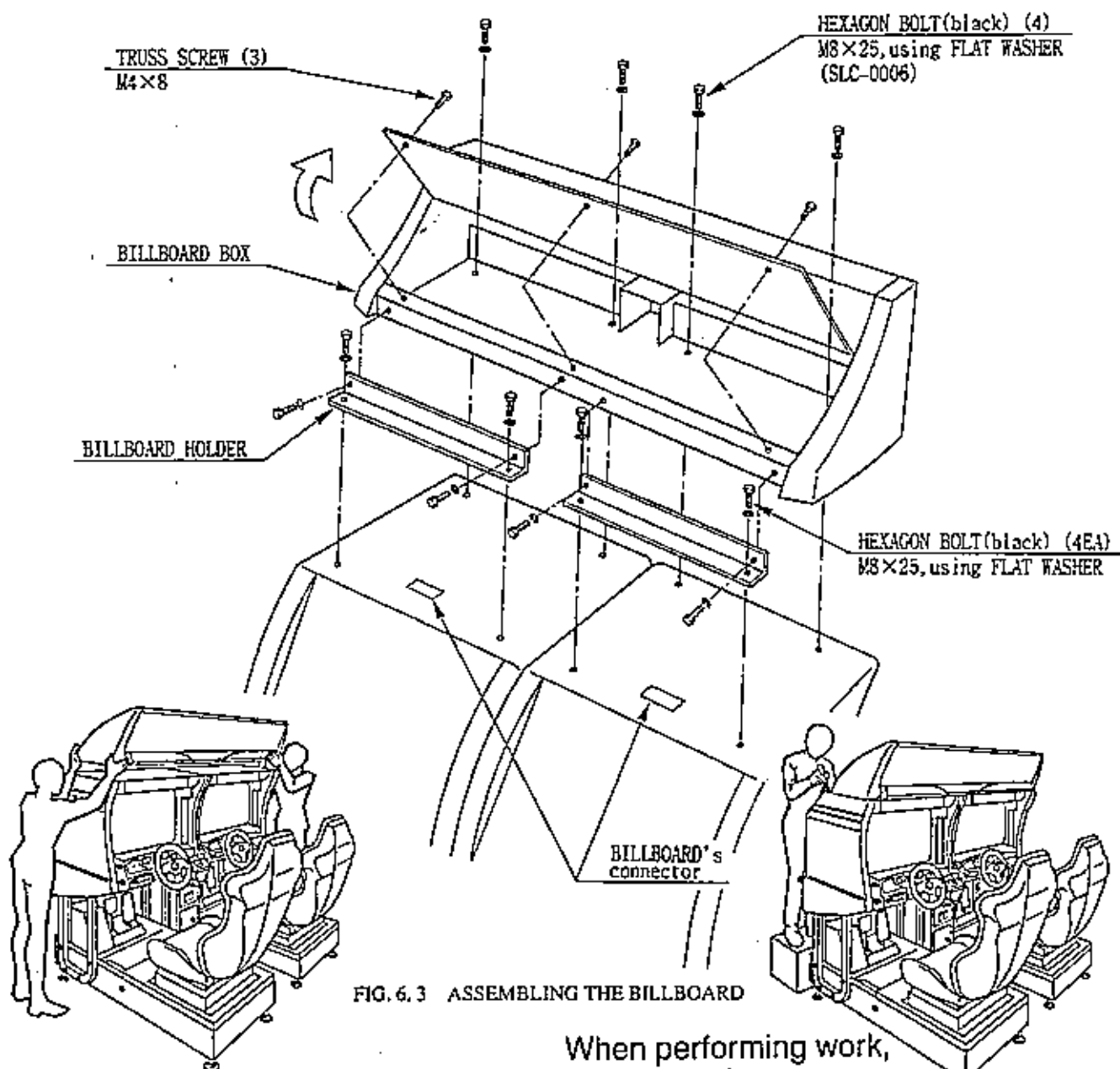

FIG. 6.3 ASSEMBLING THE BILLBOARD

When performing work,
use 2 or more persons.

When performing work,
prepare a step.

4

INSTALLING THE AC COVERS (WIRING CONNECTION)



- In order to prevent an electric shock and short circuit, be sure to turn power off before performing work by touching the interior parts of the product.
- Be careful so as not to damage wirings. Damaged wiring can cause an electric shock or short circuit accident.

The AC cover is used for protecting the wiring and optic fiber cables. When performing the work, be very careful so as not to cause damage by catching them. Pay due attention to handling optic fiber cables in particular. Ensure not to cause breakage to the cables due to excessive bending.

- ① Attach AC COVER A to the back of the cabinet (Fig. 6.4) by securing with 5 screws.
- ② Make wiring connections between both cabinets & the coin chute tower. Insert the supplied wiring connectors to the corresponding ones which have an identical color and the same number of pins.
- ③ Insert the optic fiber cables to the optic fiber connectors in a manner as applicable. There are "TX" and "RX" connectors. Make sure to connect the "TX" connector of one cabinet to the "RX" connector of the other cabinet (see sec. 20).
- ④ Secure the wiring and optic fiber cable with cord clamps in AC COVER A.
- ⑤ Install AC Cover B. Insert AC Cover B to AC Cover A from above and secure with 4 screws.

SCREW(black) (5)
M4×8 w/flat & spring washers

SCREW(black) (4)
M4×8 w/flat & spring washers

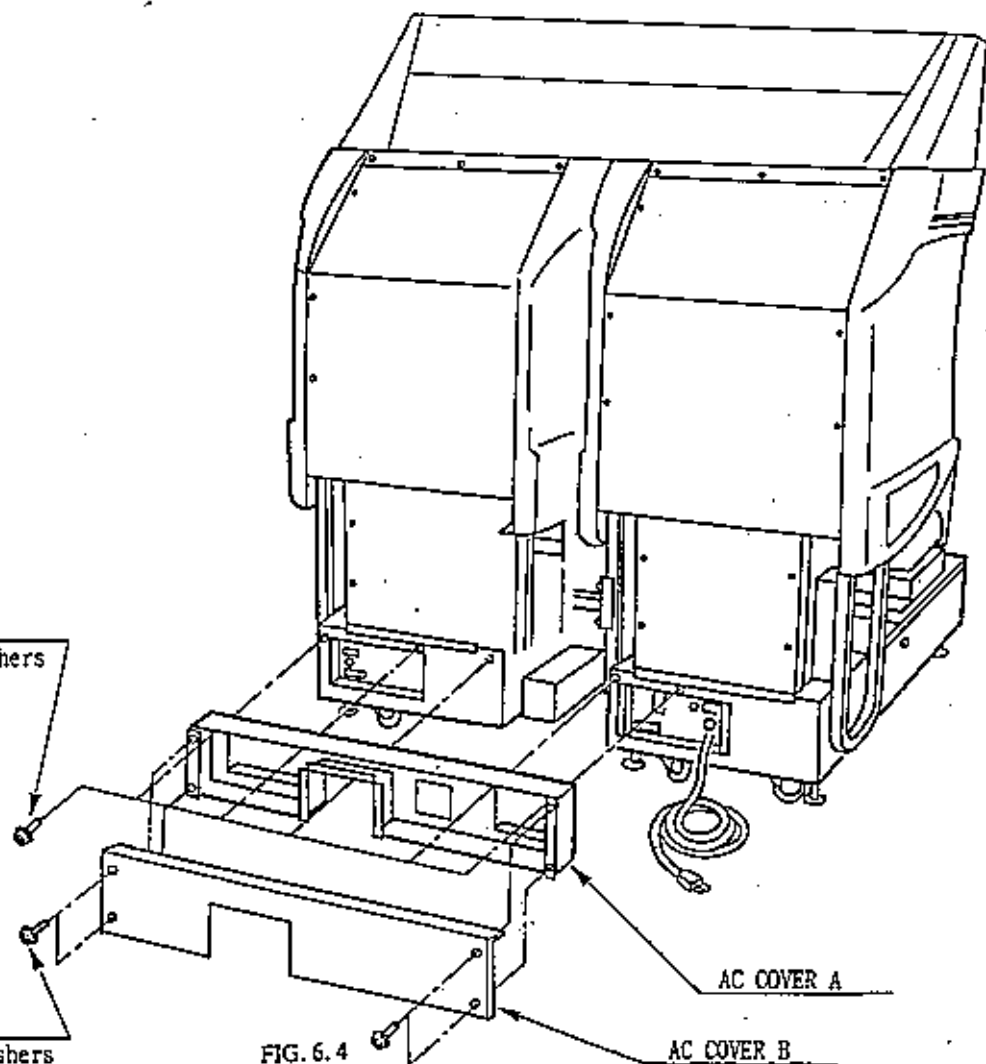

FIG. 6.4

5 POWER SUPPLY, AND EARTH CONNECTION



- Be sure to independently use the power supply socket outlet equipped with an Earth Leakage Breaker. Using a power supply without an Earth Leakage Breaker can cause a fire when the leakage occurs.
- Ensure that the "accurately grounded indoor earth terminal" and the earth wire cable are available (except in the case where a power cord plug with earth is used). This product is equipped with the earth terminal. Connect the earth terminal and the indoor earth terminal with the prepared cable. If the grounding work is not performed appropriately, customers can be subjected to an electric shock, and the product's functioning may not be stable.
- Ensure that the power cord and earth wire are not exposed on the surface (passage, etc.). If exposed, they can be caught and are susceptible to damage. If damaged, the cord and wire can cause an electric shock or short circuit. Ensure that the wiring position is not in the customer's passage way or the wiring has protective covering.

- ① The AC Unit is mounted on the 1P COCKPIT. The AC Unit incorporates the Main SW, earth terminal and power cord. Note that FIG. 6. 5 a shows the AC Unit as per Specifications for the AC 110~120V Area. The AC Unit of the AC 220~240V Area Specifications has a connector called "INLET" to which the Power Cord is to be connected.

- ② Ensure that the Main SW is OFF.

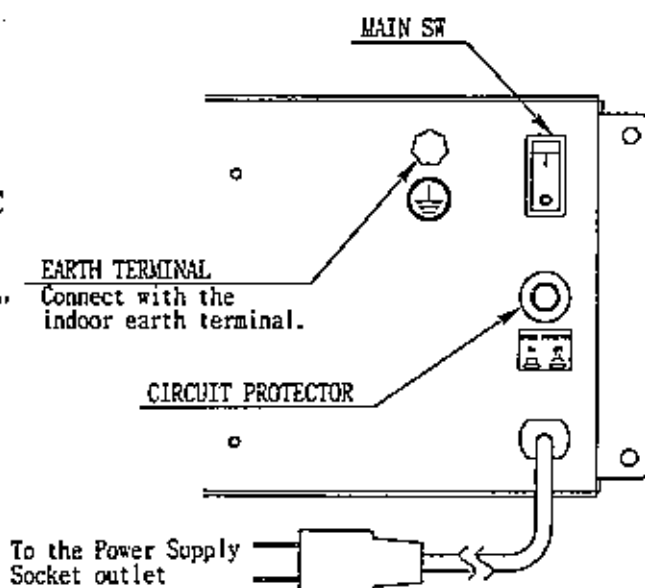

FIG. 6. 5 a AC unit

- ③ Connect one end of the earth wire to the AC Unit earth terminal, and the other end to the indoor earth terminal. The AC Unit earth terminal has a Bolt and Nut combination. Take off the Nut, pass the earth wire through the Bolt, and fasten the Nut. Note that the Earth Wire is incorporated in the Power Cord for the Areas of AC 120V (USA) and AC 220~240V, and therefore, this procedure is not necessary.

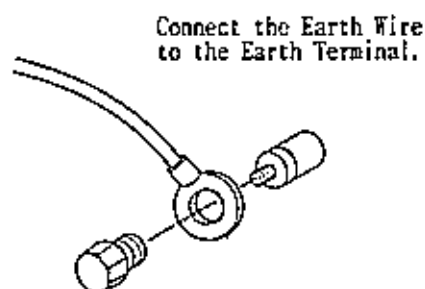

FIG. 6. 5 b Earth Wire Connection

- ④ Firmly insert the power plug into the socket outlet.
For the AC 220~240V Area, insert the opposite side of Power Cord plug to the AC Unit's connector ("INLET").
- ⑤ Perform wiring for the Power Cord and Earth Wire. Install protective covering for the Power Cord and Earth Wire.

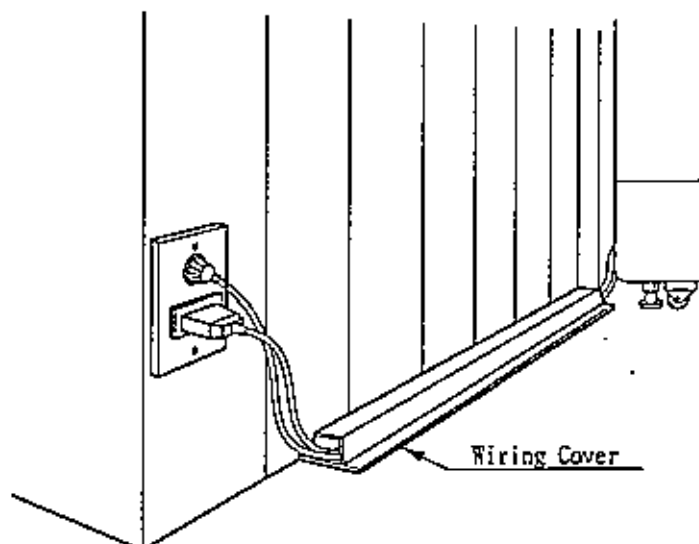

FIG. 6. 5 c Connecting Power Cord and Earth Wire

6 TURNING THE POWER ON

Turning the AC UNIT's MAIN SW on will cause the machine to start the POWER ON check and NETWORK check automatically.

In the POWER ON check, the steering wheel turns left and right, then returns to the centering position and stops. In this check, the values of V. R. inside the control panel are corrected.

Until the check is finished (the steering wheel stops automatically), do not touch the steering wheel or play the game.

If you do, the steering wheel reaction during the game (reaction at the time of a course-out or crashing) can not be obtained correctly.

In a case of a abnormal reaction during the game, turn the power on again from the beginning and complete the power-on check.

Note that turning power on when the Steering Wheel is fully turned right or left may sometimes not allow for performing power on check satisfactorily. Ensure the Steering Wheel is in the centering position, and then turn on power.

During network checking, "NETWORK CHECKING" flashes on the screen. When NETWORK CHECKING is finished, the DEMO mode will appear on the monitor screen.

After 10 seconds, if the network check is not finished, check connections for Communication.

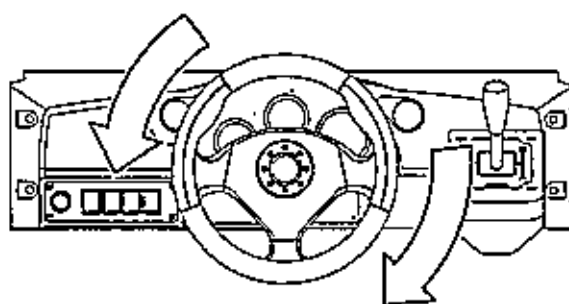

The steering wheel turns left/right automatically.

FIG. 6. 6

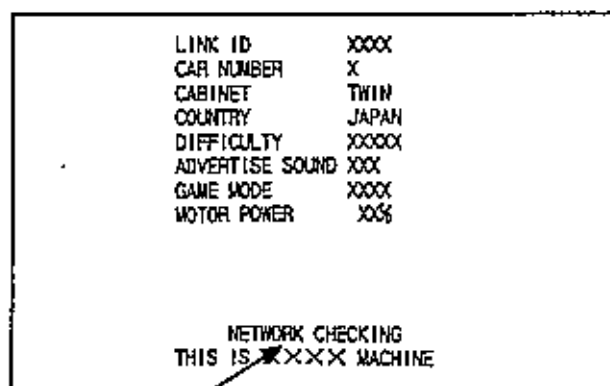

NETWORK CHECKING flashes.

7 ASSEMBLY CHECK

In the TEST MODE, ensure that the assembly has been made correctly and IC BD. is satisfactory (refer to Section 9).

In the test mode, perform the following test:

(1) MEMORY TEST

```
CPU RAM TEST
GOOD (SDRAM)      IC. 13 IC. 15
GOOD (BACKUP SRAM) IC. 21 IC. 22
GOOD (SCROLL SDRAM) IC. 04 or IC. 13 IC. 20
GOOD (SCROLL SRAM) IC. 17 IC. 18
```

PRESS TEST BUTTON TO CONTINUE

Selecting the MEMORY TEST on the test mode menu screen causes the on-board memory to be tested automatically. The game board is satisfactory if the display beside each IC No. shows GOOD.

(2) INPUT TEST

```
INPUT TEST
CHUTE#1 OFF CHUTE#2 OFF
SHIFT1 OFF SHIFT2 OFF
SHIFT3 OFF SHIFT4 OFF
VIEW1 OFF VIEW2 OFF
VIEW3 OFF VIEW4 OFF
START OFF
TEST OFF B TEST OFF
SERVICE OFF B SERVICE OFF
HANDLE 80H
ACCEL 30H
BRAKE 30H
```

PRESS SERVICE+TEST BUTTON TO EXIT

Selecting the INPUT TEST on the test mode menu screen causes the screen (on which each switch and V. R. are tested) to be displayed. Press each switch. For the coin switch test, insert a coin from the coin inlet with the coin chute door being open. If the display beside each switch indicates "ON," the switch and wiring connections are satisfactory. Check the display of V. R. value for the steering wheel and accelerator & brake. If the V. R. values are not satisfactory, refer to Sections 10 & 11.

(3) OUTPUT TEST

```
OUTPUT TEST
START ON
VIEW1 OFF
VIEW2 OFF
VIEW3 OFF
VIEW4 OFF
LEADER OFF
```

PRESS TEST BUTTON TO EXIT

In the output test mode, carry out lamp test to ensure that each lamp lights up satisfactorily.

(4) SOUND TEST

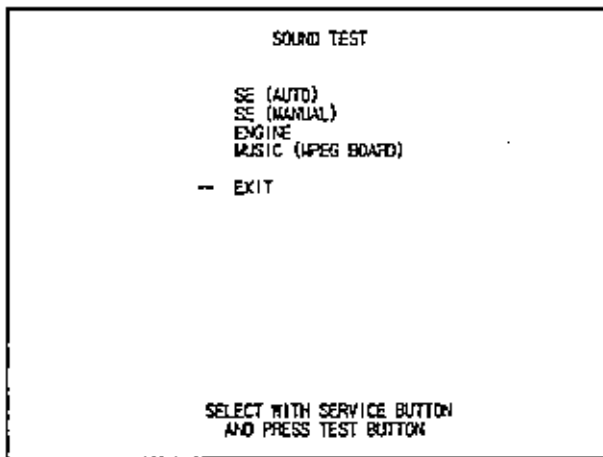

In the TEST mode, selecting SOUND TEST causes the screen (on which sound related BD and wiring connections are tested) to be displayed. Be sure to check if the sound is satisfactorily emitted from each speaker and the sound volume is appropriate.

(5) C.R.T. TEST

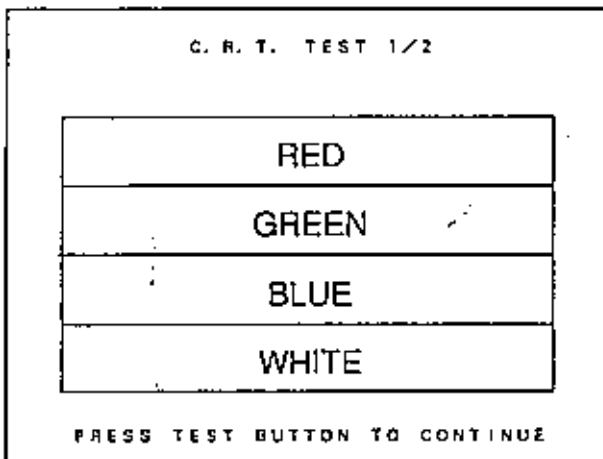

In the TEST mode menu, selecting C.R.T. TEST allows the screen (on which the monitor is tested) to be displayed. Although the monitor adjustments have been made at the time of shipment from the factory, make judgment as to whether an adjustment is needed by watching the test mode screen. If it is necessary, adjust the monitor by referring to Section 14. Use the DEMAGNETIZER SW for the color deviation caused by the monitor's magnetization (refer to Section 9).

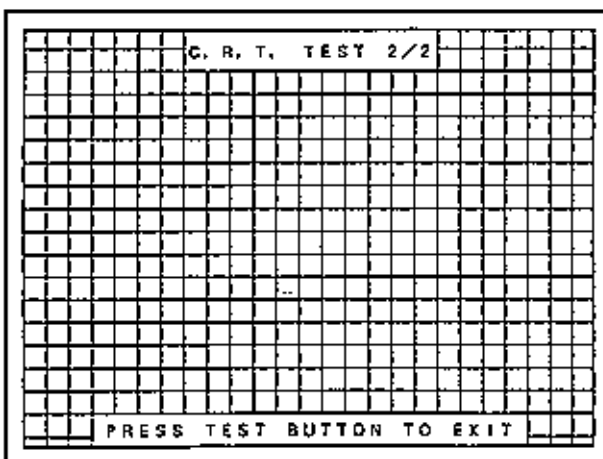

Perform the above inspections also at the time of monthly inspections.

7. PRECAUTIONS TO BE HEEDED WHEN MOVING THE MACHINE



WARNING!

- When moving the machine, be sure to pull out the plug from the power supply. Moving the machine with the plug as is inserted can damage the power cord and cause a fire or electric shock.
- When moving the machine on the floor, retract the Adjusters and ensure that Casters make contact with the floor. During transportation, pay careful attention so that Casters do not tread power cords and earth wires. Damaging the power cords can cause an electric shock and or short circuit.
- When moving the machine, do not push the cabinet from the left/right direction. Pushing the cabinet from the left/right direction can cause the cabinet to fall down, resulting in injury and or parts damage.



IMPORTANT!

When transporting the product in places with step-like differences in grade, disassemble into each unit before transporting. Inclining the product in an as is assembled condition or placing the cabinet in places with step-like grade differences can damage the unit's joining portions.

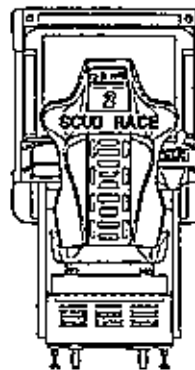
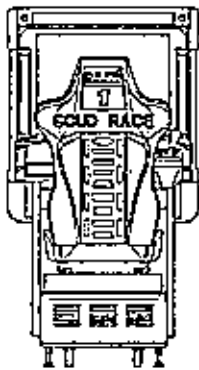

When transporting the product in places with step-like differences in grade, disassemble into each unit before transporting.

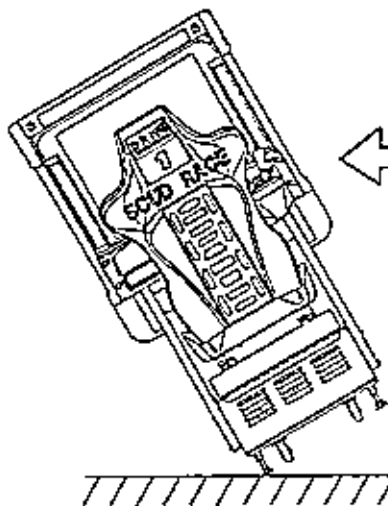

Do not push an independent (detached) cockpit from the left/right direction.

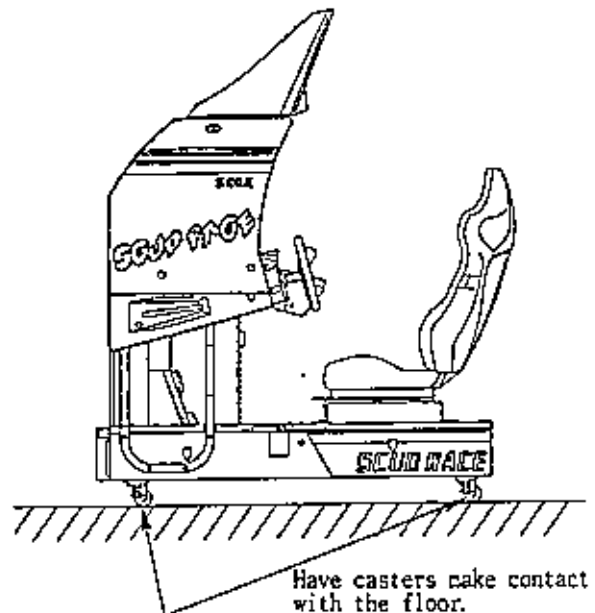

FIG. 7

8. CONTENTS OF GAME

The following explanations apply to the case the product is functioning satisfactorily. Should there be any moves different from the following contents, some sort of faults may have occurred. Immediately look into the cause of the fault and eliminate the cause thereof to ensure satisfactory operation.

During the ADVERTISE mode, the View Change button and Start button Lamp light up periodically. When the product is energized, the Billboard's fluorescent lamp is always lit. The Leader Lamp (below the fluorescent lamp) flashes periodically. During the ADVERTISE mode, sound is emitted from all of the Speakers. Note 1

- ① Get in the Cockpit. The seat can be adjusted in forward and rearward positions. The Lever is located on the lower right (facing the screen) of the Seat. Pull this Lever to make adjustments.
- ② Insert a coin(s). Number of coins is displayed on the lower left of the screen. Inserting one play worth of coin(s) causes the SELECT screen to be displayed.
Up to 9 credits can be counted at one time. Coins inserted after counting 9 credits will neither be counted nor returned. Credits will not be displayed in the SELECT mode and during the game play (credits are displayed only during ADVERTISE).
- ③ When a coin is inserted to one of the machines linked for communication, the other unit's screen will be in the entry accepting mode, and countdown starts. For Entry, the player is to insert a coin(s) during countdown.
- ④ Select sequentially in order of COURSE, CAR, and TRANSMISSION. Turn the Steering Wheel to choose and decide the selection by stepping on the Accelerator Pedal.

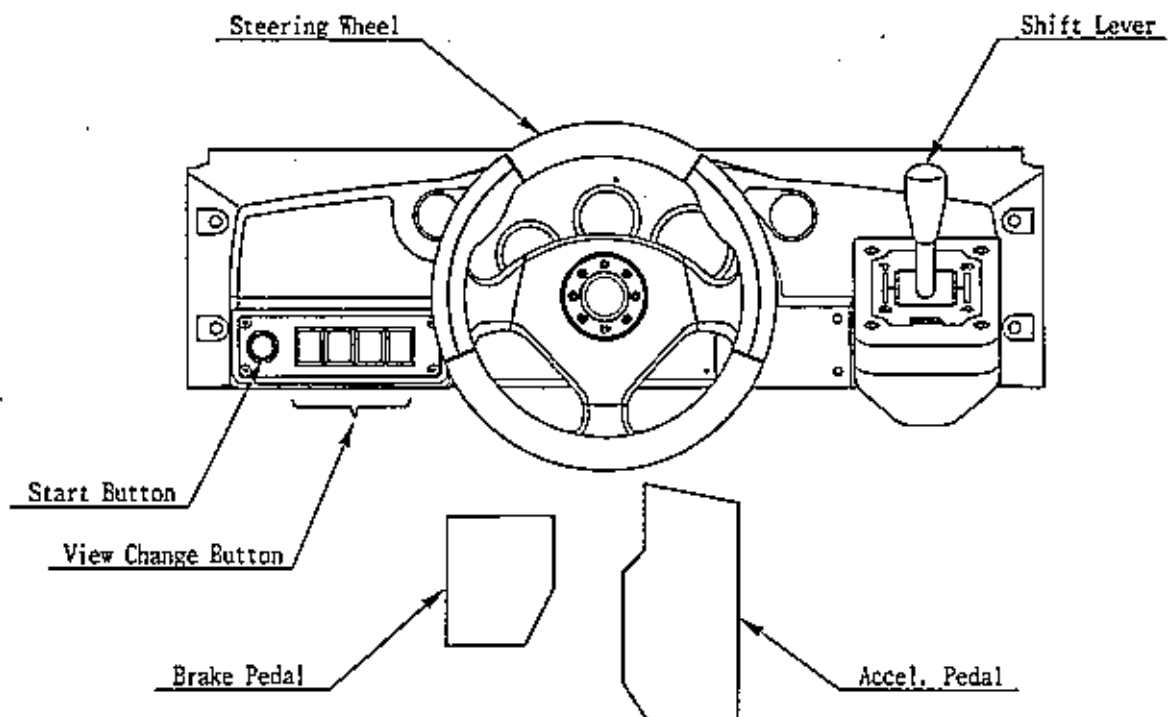
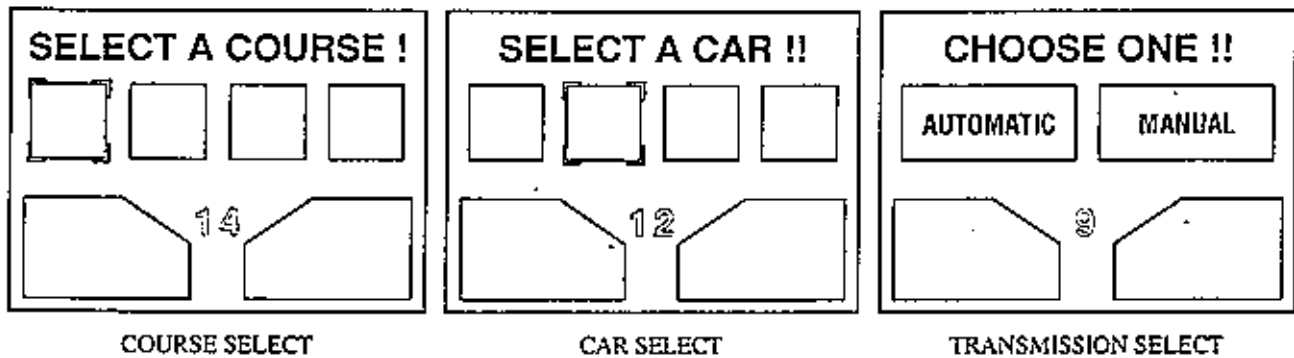

FIG. 8

Displaying the **SELECT** mode starts countdown. When the countdown becomes 0, the **COURSE** and **CAR** being chosen are determined automatically.

Stepping on the **Accel. Pedal** again after stepping on it once will have the present **SELECT** screen, in the middle of counting down, proceed to the next **SELECT** screen.

Course selection is decided by majority. In case of a tie, the left-hand side course on the **SELECT** screen has priority.



- ⑤ Choosing and deciding on either Automatic or Manual (4-shifts) will result in a race start. At this time, while pressing the Start button, step on the **Accel. Pedal** to decide on the selection to play in the **PLAYER ONLY** mode.

Simultaneously with race start, the **Lamps** in the **Control Panel** light up and the **View Change** button being selected lights up. While participating in the race, if the player becomes the leader, that particular seat's **Leader Lamp** flashes. The **Steering Wheel** is subject to the reaction and load depending on the status of the **Course**, **Course Out** and **Crash**. Note 2

- ⑥ The number of **Laps** is displayed on the upper left of the screen, and **Lap Time** is shown below the upper left. **Tachometer** and **Time Limit** (remaining time) as well as **Speed** are shown on the upper center portions. **Position**, **Condition** and **Course Map** are displayed sequentially in order from the upper right portion of the screen downward. If **Manual Transmission** is selected, **Gear Position** will be shown to the right side of **Speed**.

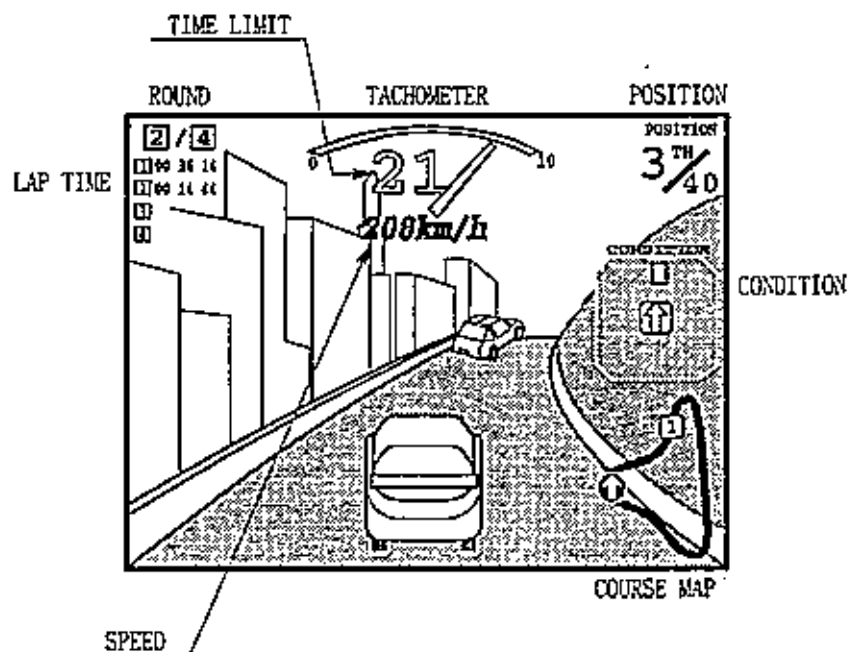

- ⑦ Simultaneously with race start, the **Time Limit** decreases. Passing a **Course's Check Point** allows the game to be continued with the remaining time of the previous section added to the **Time Limit** up to the next **Check Point**. Failing to pass the **Check Point** within the **Time Limit** results in **GAME OVER**.

- ⑧ When the race participants' leader finishes the specified number of laps of each course, the game is over then. Note 3: The game is over also when all of the race participants fail to pass the checkpoint within the time limit.
- ⑨ Upon finishing one game, if one play worth of credits or more credits remain, the SELECT screen will be displayed.
- ⑩ Excellent players can enter his name. Select name characters by turning the Steering Wheel clockwise or counterclockwise and decide by stepping on the Accel. Pedal.

Note 1 During ADVERTISE, setting to No Sound output is possible.

Note 2 The strength (strong or weak) of the Steering Wheel is changeable.

Note 3 The setting of Lap frequency is changeable.

9. EXPLANATION OF TEST AND DATA DISPLAY

By operating the switch unit, periodically perform the tests and data check. When installing the machine initially or collecting cash, or when the machine does not function correctly, perform checking in accordance with the explanations given in this section. The following shows tests and modes that should be utilized as applicable.



CAUTIONS TO BE HEEDED WHEN USING THE TEST MODE:

- In the case where multiple units are linked for communication play, exiting from the test mode causes the unit to perform the network check automatically. During this time, all of the linked units will not allow the game to be played in normal status. Therefore, be sure not to enter the test mode if any one of the units is in play. On the other hand, if even one unit is in the test mode, make sure that other machines are not in play.
- In this product, the power-on check is performed when the Test Mode is exited, as when turning power on. Do not touch the Steering Wheel until it stops automatically. Touching before it stops may not allow for satisfactory reaction of Steering Wheel during game play.

TABLE 9 EXPLANATION OF TEST MODE

ITEMS	DESCRIPTION	REFERENCE SECTIONS
INSTALLATION OF MACHINE	When the machine is installed, perform the following: 1. Check to see that each setting is as per standard setting made at the time of shipment. 2. In the INPUT TEST mode, check each SW and VR. 3. In the OUTPUT TEST mode, check each of lamps. 4. In the SELF-TEST mode, check ICs on the IC Board.	9-9, 9-10 9-5 9-6 9-3, 9-4
MEMORY	Choose MEMORY TEST in the MENU mode to allow the MEMORY test to be performed. In this test, PROGRAM RAMs, ROMs, and ICs on the IC Board are checked.	9-3
PERIODIC SERVICING	Periodically perform the following: 1. MEMORY TEST 2. Ascertain each setting. 3. In the INPUT TEST mode, test the CONTROL device 4. In the OUTPUT TEST mode, check each of lamps.	9-3, 9-4 9-9, 9-10 9-5 9-6
CONTROL SYSTEM	1. In the INPUT TEST mode, check each SW and VR. 2. Adjust or replace each SW and VR. 3. If the problem can not be solved yet, check the CONTROL's moves.	9-5 10, 11, 12
MONITOR	In the MONITOR ADJUSTMENT mode, check to see if the PROJECTOR adjustment is appropriately made.	9-8 14
IC BOARD	1. MEMORY TEST 2. In the SOUND TEST mode, check the sound related ROMs.	9-3, 9-4 9-7
DATA CHECK	Check such data as game play time and histogram to adjust the difficulty level, etc..	9-11

9-1 SWITCH UNIT AND COIN METER



Never touch places other than those specified. Touching places not specified can cause electric shock and short circuit.



- Adjust to the optimum sound volume by considering the environmental requirements of the installation location.
- If the COIN METER and the game board are electrically disconnected, game play is not possible.

SWITCH UNIT

Open the coin chute door, and the switch unit shown will appear. The functioning of each SW is as follows:

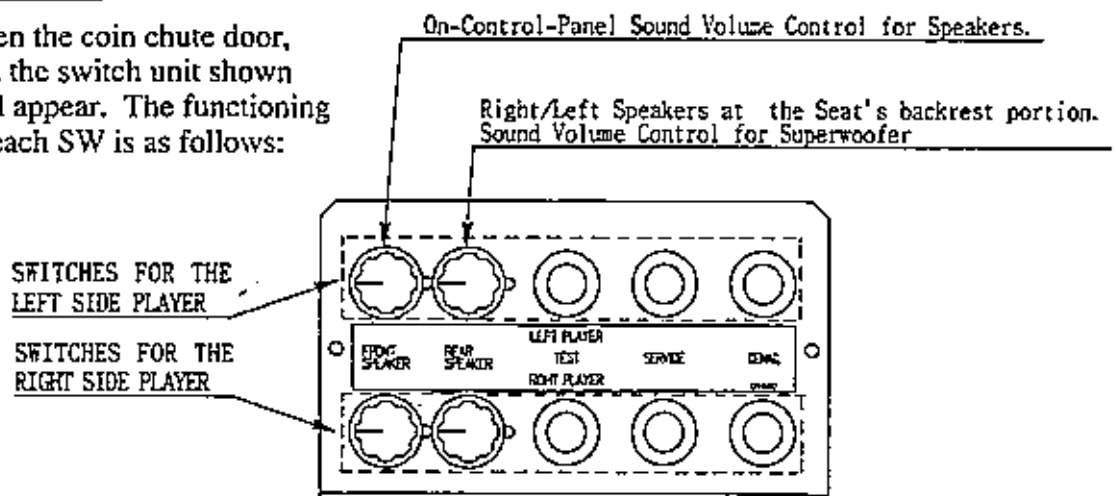

FIG. 9.1 a SWITCH UNIT

TEST BUTTON:
TEST SW

For the handling of the test button, refer to the following pages.

SERVICE BUTTON:
SERVICE SW

Gives credits without registering on the coin meter.

COIN METER

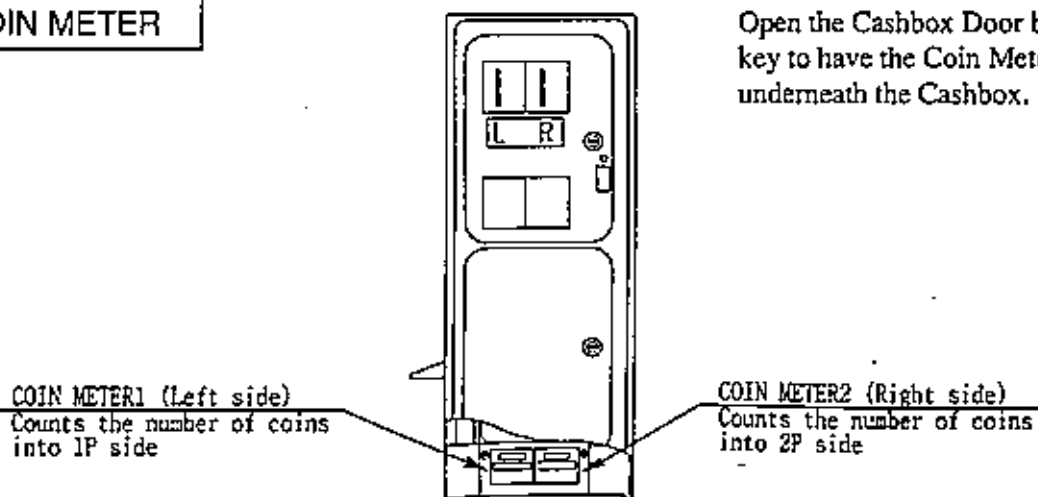

FIG. 9.1 b

Open the Cashbox Door by using the key to have the Coin Meter appear underneath the Cashbox.

9-2 TEST MODE



When changes are made in the settings of GAME ASSIGNMENTS, COIN ASSIGNMENTS and DRIVE BOARD TEST, be sure to exit from the Test Mode to return to the Game Mode. (If the power is turned OFF in the Test Mode, the settings can not be rewritten.)

The Test Menu allows the functioning of each part of the Cabinet to be checked, the monitor to be adjusted, and the coins and game related various settings to be performed.

- Press the test button to have the menu displayed on the screen and enter the test mode (FIG.9.2).
- Press the SERVICE BUTTON until the pointer "→" is moved to the desired item to make a selection.
- Bring the pointer "→" to the desired item and press the TEST BUTTON to enter the selected item's test.
- In the Test mode, View Change button 3 (yellow) instead of the Test button can be used, and View Change buttons 1 (red) & 2 (blue) instead of the Service button (for moving the arrow) can be used.

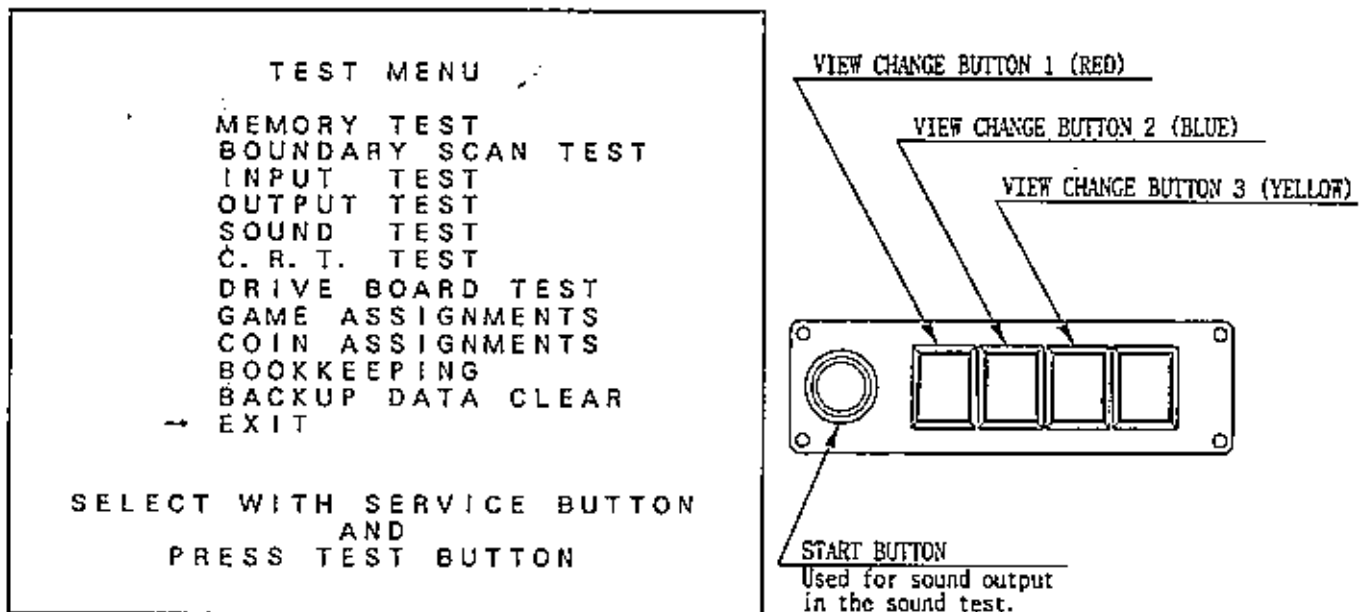

FIG. 9.2 TEST MENU

- Choose EXIT and press the test button to exit from the test mode and return to the game mode.

9-3 MEMORY TEST



When the Memory Test is finished, have the Menu mode return on the screen, turn the power off and turn it back on again. To prevent malfunctioning, the IC Board initialization is performed by turning the power off and then turning it back on again.

The MEMORY TEST mode is for automatically checking the on-BD memory IC functioning. "GOOD" is displayed for normal ICs and "BAD" is displayed for abnormal ICs.

```

CPU RAM TEST
GOOD (SDRAM)          IC. 13 IC. 15
GOOD (BACKUP SRAM)   IC. 21 IC. 22
GOOD (SCROLL SDRAM)  IC. 94 or IC. 19 IC. 20
GOOD (SCROLL SRAM)   IC. 17 IC. 18

PRESS TEST BUTTON TO CONTINUE
    
```

FIG. 9.3 a CPU RAM TEST

- When the test is completed, if the results are shown as above, it is satisfactory.
- During the test, TESTING NOW is displayed on the lower part of the screen. After an elapse of 5 minutes, if the test is not finished, the IC Board may be malfunctioning.
- Upon finishing the test, press the Test button to proceed to "CPU ROM TEST."

```

CPU ROM TEST
GOOD (CROM03MASK)    IC. 1 XXXX
GOOD (CROM02MASK)    IC. 2 XXXX
GOOD (CROM01MASK)    IC. 3 XXXX
GOOD (CROM00MASK)    IC. 4 XXXX
GOOD (CROM13MASK)    IC. 5 XXXX
GOOD (CROM12MASK)    IC. 6 XXXX
GOOD (CROM11MASK)    IC. 7 XXXX
GOOD (CROM10MASK)    IC. 8 XXXX
GOOD (CROM23MASK)    IC. 9 XXXX
GOOD (CROM22MASK)    IC. 10 XXXX
GOOD (CROM21MASK)    IC. 11 XXXX
GOOD (CROM20MASK)    IC. 12 XXXX
GOOD (CROM33MASK)    IC. 13 XXXX
GOOD (CROM32MASK)    IC. 14 XXXX
GOOD (CROM31MASK)    IC. 15 XXXX
GOOD (CROM30MASK)    IC. 16 XXXX
GOOD (CROM3 EPROM)   IC. 17 XXXX
GOOD (CROM2 EPROM)   IC. 18 XXXX
GOOD (CROM1 EPROM)   IC. 19 XXXX
GOOD (CROM0 EPROM)   IC. 20 XXXX

PRESS TEST BUTTON TO CONTINUE
    
```

FIG. 9.3 b CPU ROM TEST

- During the test, the TESTING NOW message is displayed on the lower part of the screen. Upon finishing the test, if the above is displayed, it is satisfactory.
- After finishing the test, press the Test button to proceed to "VIDEO RAM TEST."

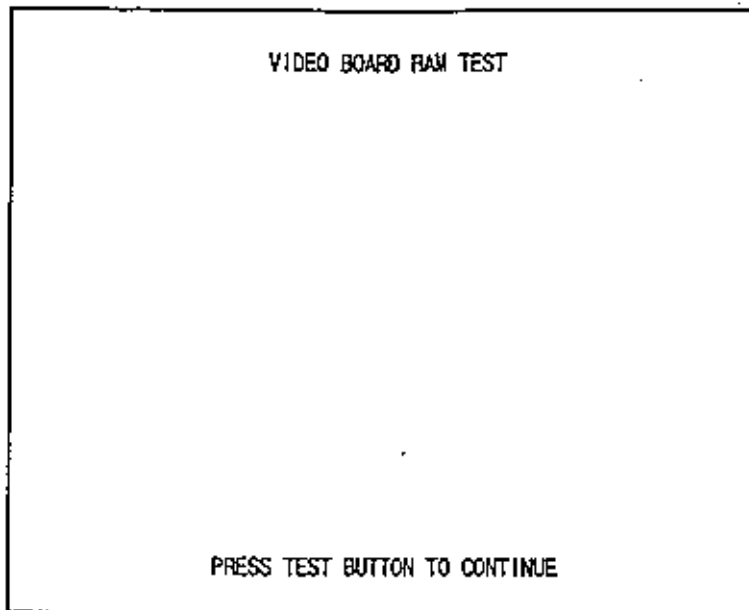

FIG. 9.3 c VIDEO BOARD RAM TEST

- During the test, the TESTING NOW message is displayed on the lower part of the screen. Upon finishing the test, if there is no irregularity, nothing will be shown as above.
- After finishing the test, press the Test button to proceed to "VIDEO BOARD ROM TEST."

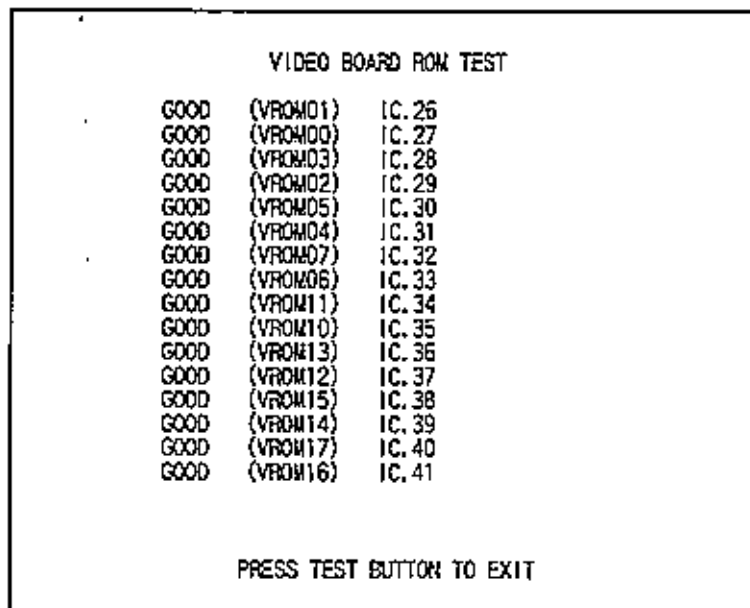

FIG. 9.3 d VIDEO BOARD ROM TEST

- During the test, the TESTING NOW message is displayed on the lower part of the screen. After finishing the test, if the above is displayed, it is satisfactory.
- After finishing the test, press the Test button to return to the Menu screen (FIG. 9.2). Then, turn off power and turn it back on again. IC Board initialization is performed by turning the power off and then turning it back on again. Failing to do this turning off-on procedure can cause malfunctioning.

9-4 BOUNDARY SCAN TEST



Upon finishing the test, cause the Test Menu to return on the screen, turn the power off and turn it back on again. By so doing, the Board initialization is performed to avoid malfunctioning.

Selecting "BOUNDARY SCAN TEST" causes the Game Board's testing in terms of hardware to be performed automatically.

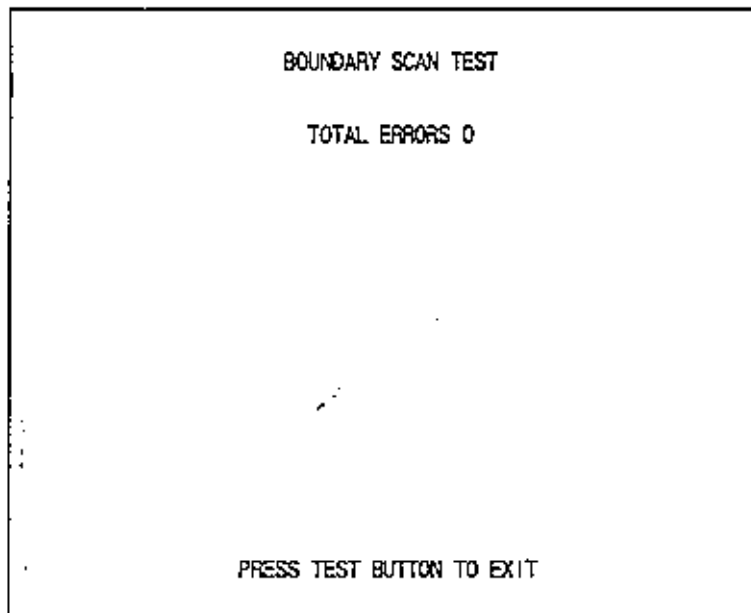

FIG. 9.4 BOUNDARY SCAN TEST

- When the test is completed, if the results are shown as above, it is satisfactory.
- After finishing the test, press the Test button to have the Menu mode return on the screen. Next, turn the power off and then turn it back on again. By so doing, the Board initialization is performed to avoid malfunctioning.
- If there is any hardware problems, error message is displayed. Please contact the offices herein stated or where the product was purchased from.

9-5 INPUT TEST

Selecting INPUT TEST displays the following on the screen and enables you to check the status of each switch and each Volume value of the cabinet.

On this screen, periodically check the status of each switch & V.R.

- By pressing each switch, if the display on the right-hand side of the name of each switch changes to ON from OFF, the SW and the wiring connections are satisfactory.
- To check the Coin SW of "CHUTE #X", open the Coin Chute Door and insert a coin into the Coin Inlet.
- B TEST and B SERVICE are on the Game Board. Normally, they are not used.
- Simultaneously pressing the Service button and the Test button returns the Test Menu on the screen.

CHUTE#1	OFF	CHUTE#2	OFF
SHIFT1	OFF	SHIFT2	OFF
SHIFT3	OFF	SHIFT4	OFF
VIEW1	OFF	VIEW2	OFF
VIEW3	OFF	VIEW4	OFF
START	OFF		
TEST SERVICE	OFF	B TEST	OFF
		B SERVICE	OFF
HANDLE	80H		
ACCEL	30H		
BRAKE	30H		

PRESS SERVICE+TEST BUTTON TO EXIT

FIG. 9.5 a INPUT TEST

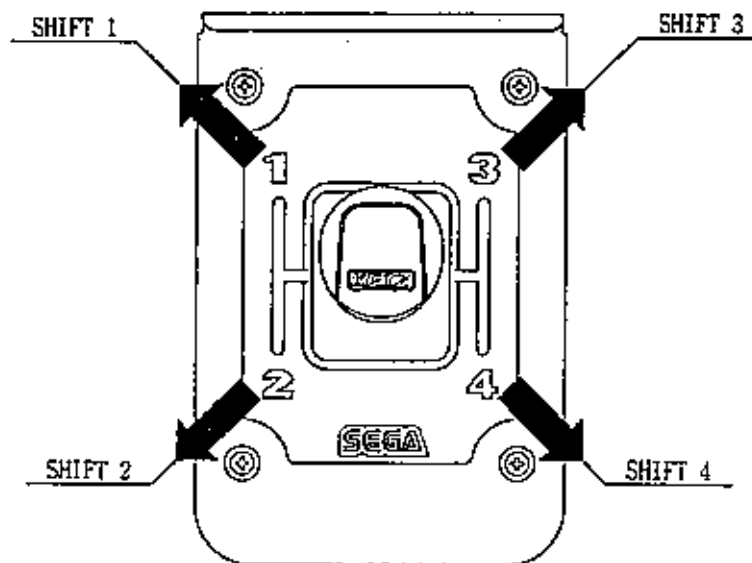

FIG. 9.5 b

The reference values for adjusting each Volume are as follows.

When the Steering Wheel and the Pedal are operated, if the corresponding Volume value varies in a natural manner within the following range, it is satisfactory.

HANDLE : 80H ± 2 (Centering Position)

ACCEL. : When the Pedal is released ← Under 30 H → When the Pedal is stepped on. Over 60H

BRAKE : Under 30 H → Over 60H

If the Volume value is not within the above range, movements are not satisfactory.

By referring to the Owner's Manual, adjust or replace the Volume.

9-6 OUTPUT TEST

This test allows the functioning of the button lamp on the switch panel and the leader lamp to be checked.

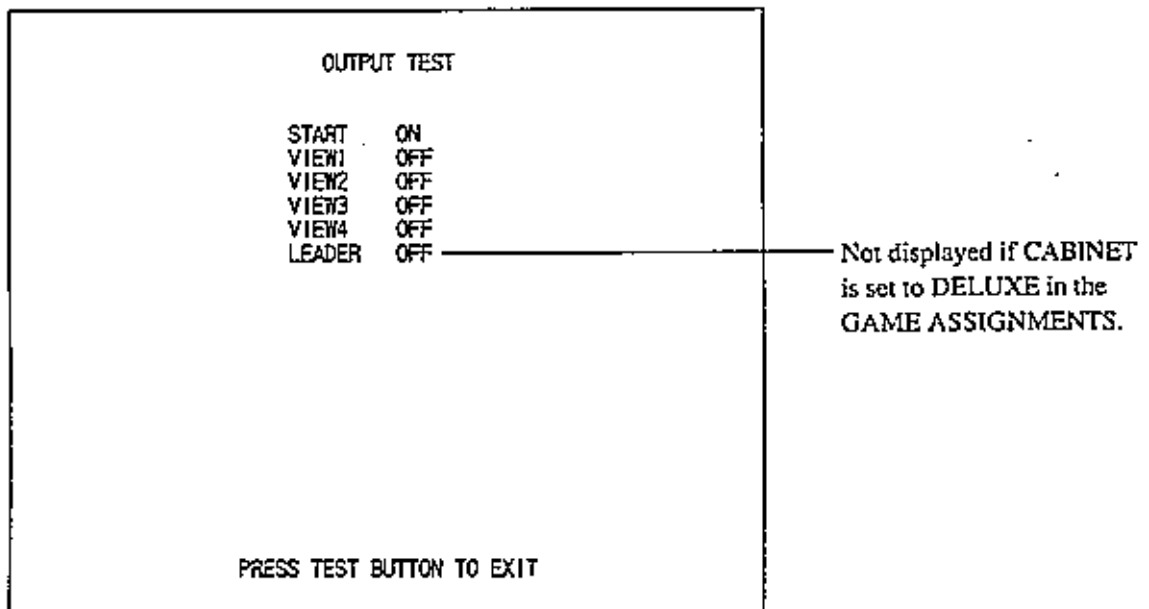

FIG. 9.6 OUTPUT TEST

Selecting OUTPUT TEST displays the above screen. The 4 View Change buttons and Start Button Lamp on the Switch Panel, and the Leader Lamp light up and go off sequentially in order. If the lamp lights up when the display beside the name is ON and goes off when the display is OFF, the wiring connection is satisfactory.

9-7 SOUND TEST

This test mode allows each sound related board and speaker to be checked.

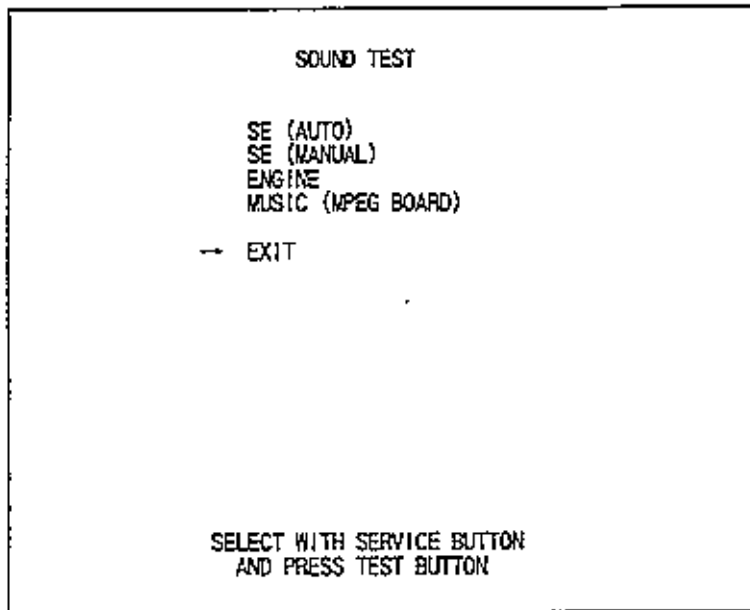

FIG. 9.7 a SOUND TEST MENU

- Press the Service button to select the sound to be tested, and press the Test button to have the selected Sound Test screen appear.
- Select EXIT and press the Test button to return to the Test Menu.

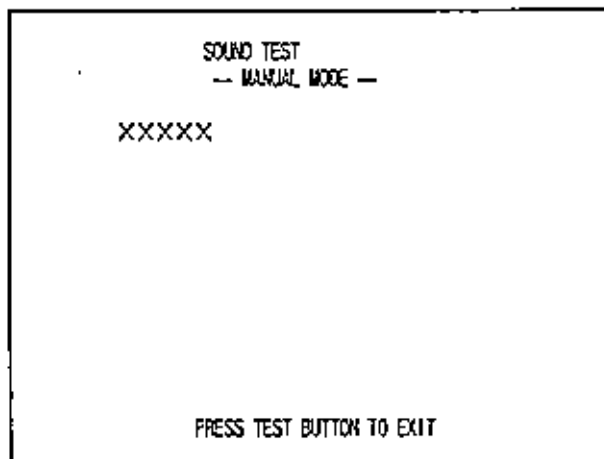

FIG. 9.7 b SOUND TEST

- Press the Service button to select the sound to be tested, and press the Start button to have sound emitted.
- Press the Test button to have Sound Test Menu return on the screen.

9-8 C.R.T. TEST

Choose C.R.T. TEST to have the Monitor Adjustment check screen appear. By watching the screen, periodically check if adjustments are needed. For the adjustment method, read Section 14.

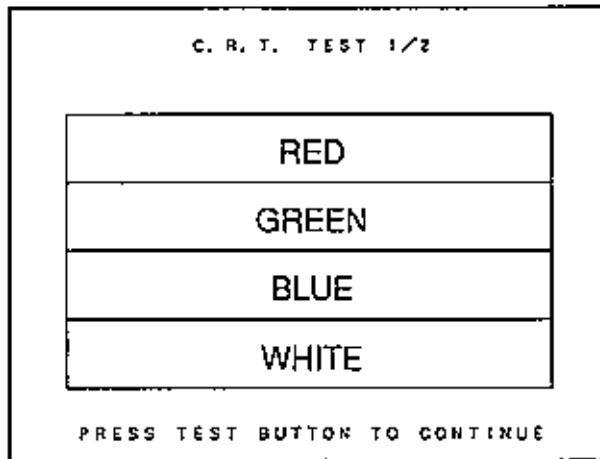

FIG. 9.8 a C.R.T. TEST (1/2)

In the screen as per FIG. 9.8 a, check Monitor color adjustments. By watching this screen, make color adjustments. Each of the R (red), G (green), B (Blue) and White is darkest at the left-hand end and becomes brighter towards the right-hand end.

Press the TEST BUTTON to have the following Crosshatch screen appear.

In the screen as per FIG. 9.8 b, check monitor size and position adjustments. Check size and position adjustments by watching this screen.

Adjust the Monitor to make sure that the crosshatch lines do not go beyond the screen size and crosshatch distortion does not occur.

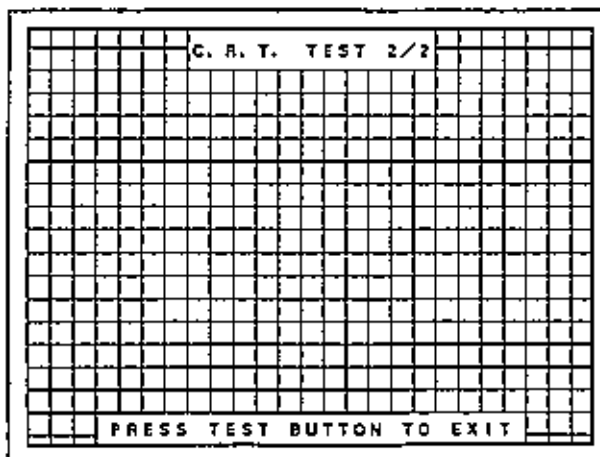

FIG. 9.8 b C.R.T. TEST (2/2)

Press the TEST BUTTON to have the menu return to the screen.

9-9 DRIVE BOARD TEST

Select DRIVE BOARD TEST to have the following screen displayed. This test allows the movement of motor, etc., to be checked and Steering Wheel Volume setting to be performed.

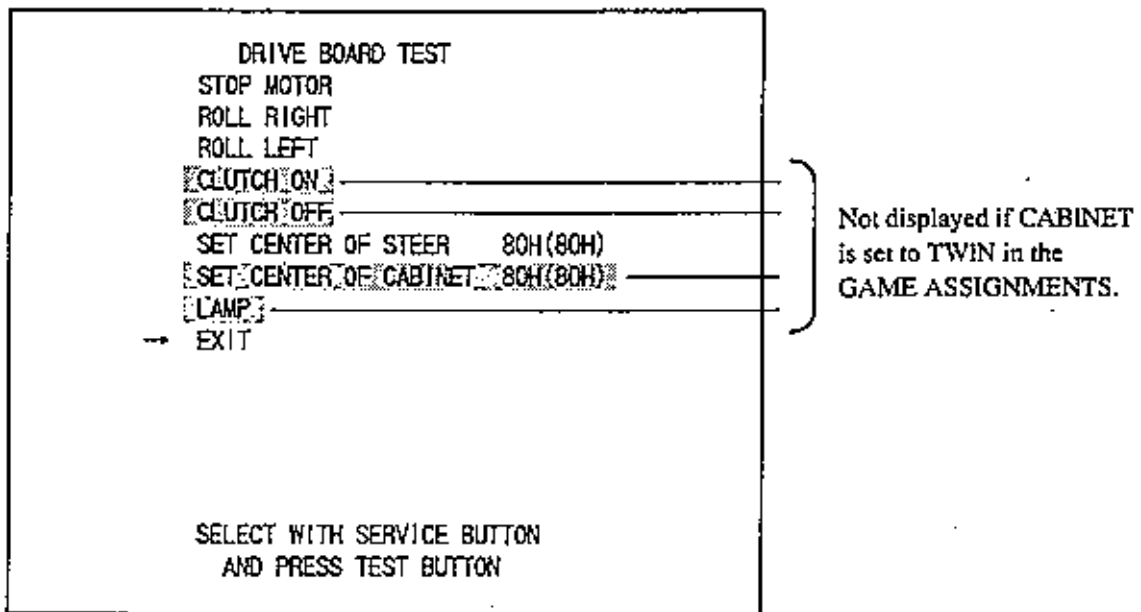

FIG. 9.9 TEST DRIVE BOARD MENU

Press the Service button to select each item and press the Test button to cause the selected item's movements to be performed.

- **STOP MOTOR :** Stops the load subjected to the Steering Wheel and the movements of the Motor for reaction. As such, initially selecting this item and pressing the Test button make no difference superficially. Select ROLL RIGHT or ROLL LEFT below this item, and in the status that the motor is functioning in a certain direction, select the item and press the Test button to stop the movements in that particular direction.
- **ROLL RIGHT :** The motor moves so as to turn the Steering Wheel clockwise.
- **ROLL LEFT :** The motor moves so as to turn the Steering Wheel counterclockwise.

SETTING THE VOLUME

Performs the setting of VOLUME which detects the movements of Steering Wheel as per FIG. 9.9. When the Steering Wheel Volume is adjusted or replaced, perform Volume setting in the following procedure.

◦ SETTING THE STEERING WHEEL VOLUME

- ① Press the Service button to bring the arrow to SET CENTER OF STEER.
- ② Secure the Steering Wheel to the Centering position.
- ③ Press the Test button. Store the Volume value obtained at this time as Steering Wheel's centering value.

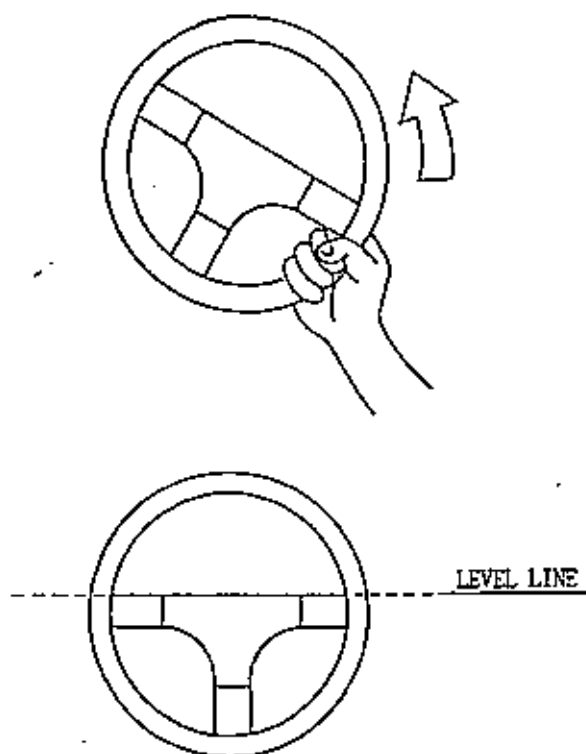

With the Steering Wheel in the centering position, press the Test button.

9-10 GAME ASSIGNMENTS

Selecting **GAME ASSIGNMENTS** in the menu mode causes the following screen to be displayed and also the game difficulty setting, etc. to be performed. Each item displays the following contents.

GAME ASSIGNMENTS	
LINK ID	MASTER
CAR NUMBER	1
CABINET TYPE	TWIN
COUNTRY	XXXX
DIFFICULTY	NORMAL
ADVERTISE SOUND	ON
GAME MODE	NORMAL (SPRINT)
MOTOR POWER	80%
MULTI DISPLAY	OFF
→ EXIT	

SELECT WITH SERVICE BUTTON
AND PRESS TEST BUTTON

FIG. 9.10 GAME ASSIGNMENTS

SETTING CHANGE PROCEDURE

- ① Press the **SERVICE BUTTON** to bring the arrow (→) to the desired setting change item.
- ② Press the **TEST BUTTON** to choose the desired setting item.
- ③ Bring the arrow to **EXIT** and press the **TEST BUTTON** to return to the menu mode.

- **LINK ID:** For communication play (see Section 20), set one seat to "MASTER" and the rest of the seats to "SLAVE." The game setting and coin setting, etc. of the MASTER seat apply to the SLAVE seats also. Note that setting changes made by the SLAVE seats are not effective for the game.
- **CAR NUMBER:** For interactive play between 2 or more machines (cabinets), the cabinets (starting from the left, facing the monitor screen) are numbered in the sequential order of No. 1, No. 2, No. 3, No. 4, If the same number is used for 2 or more cabinets, or cabinets are numbered in an incorrect sequence, on-screen display may be confused. Be careful of this point.
- **CABINET TYPE:** Setting of cabinet. Set to "TWIN" for this machine.
- **COUNTRY:** Set to USA for the United States, and set to EXPORT for other countries. For AUSTRALIA Specifications, this item is not displayed on the screen.
- **DIFFICULTY:** Sets the difficulty level in 4 categories, i.e., EASY, NORMAL, HARD, and HARDEST.
- **ADVERTISE SOUND:** Set this to ON to have sound produced during Demo mode and to OFF for not producing sound.
- **GAME MODE:** Sets the number of Laps.
The number of Laps increases sequentially in order of NORMAL (SPRINT), GRAND PRIX and ENDURANCE.
- **MOTOR POWER:** Sets the steering wheel (reaction motor) strength. When the strength is set to weak, the Cockpit swaying movement will be less. Set to in excess of 80 %.
- **MULTI DISPLAY:** This determines whether the identical scene as that of the player's monitor (in case of 1P play) is to be displayed on the monitors of the unoccupied, right and left seats immediately adjacent to the 1P player (ON) or not (OFF). This setting is effective only when the situation of the linked machinery allows 4 or more persons to play the game simultaneously.

9-11 COIN ASSIGNMENTS

The "COIN ASSIGNMENTS" mode permits you to set the start number of credits, as well as the basic numbers of coins and credits. This mode expresses "how many coins correspond to how many credits."

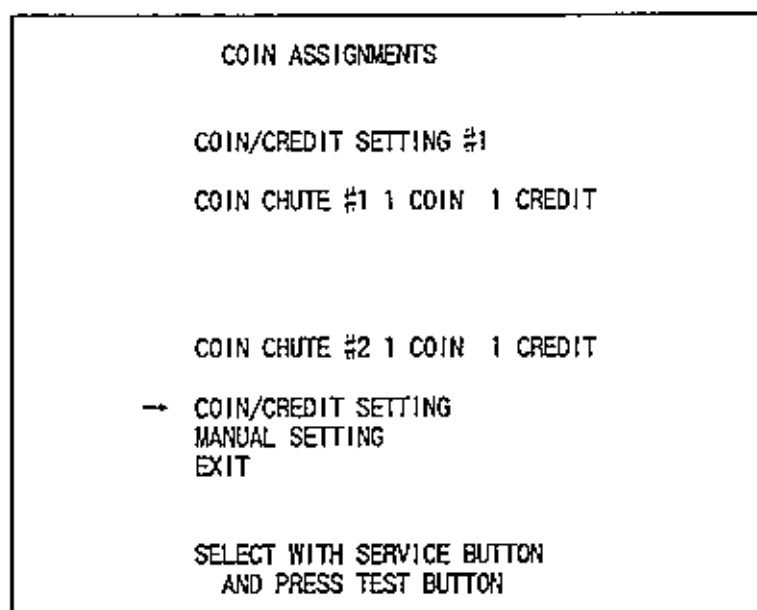

FIG. 9.11 a COIN ASSIGNMENTS

- COIN/CREDIT SETTING "How many coins correspond to how many credits." In this machine, selection as per Table 9. 11a is possible.
- MANUAL SETTING Allows for finer settings. (Table 9. 11b)

SETTING CHANGE PROCEDURE

- ① Press the Service button to bring the arrow to COIN/CREDIT setting.
- ② Press the TEST BUTTON to choose the desired setting item.
- ③ Bring the arrow to EXIT and press the TEST BUTTON to return to the menu mode.

TABLE 9.11 a COIN/CREDIT SETTING

NAME OF SETTING	FUNCTIONING OF COIN CHUTE #1		FUNCTIONING OF COIN CHUTE #2	
SETTING #1	1 COIN	1 CREDIT	1 COIN	1 CREDIT
SETTING #2	1 COIN	2 CREDITS	1 COIN	1 CREDIT
SETTING #3	1 COIN	3 CREDITS	1 COIN	1 CREDIT
SETTING #4	1 COIN	4 CREDIT S	1 COIN	1 CREDIT
SETTING #5	1 COIN	5 CREDITS	1 COIN	1 CREDIT
SETTING #6	1 COIN	2 CREDITS	1 COIN	2 CREDITS
SETTING #7	1 COIN	5 CREDITS	1 COIN	2 CREDITS
SETTING #8	1 COIN	3 CREDITS	1 COIN	3 CREDITS
SETTING #9	1 COIN	4 CREDITS	1 COIN	4 CREDITS
SETTING #10	1 COIN	5 CREDITS	1 COIN	5 CREDITS
SETTING #11	1 COIN	6 CREDITS	1 COIN	6 CREDITS
SETTING #12	2 COINS	1 CREDIT	2 COINS	1 CREDIT
SETTING #13	1 COIN	1 CREDIT	2 COINS	1 CREDIT
SETTING #14	1 COIN	2 CREDITS	2 COINS	1 CREDIT
SETTING #15	1 COIN	1 CREDIT	1 COIN	1 CREDIT
	2 COINS	3 CREDITS	2 COINS	3 CREDITS
SETTING #16	1 COIN	3 CREDIT S	1 COIN	1 CREDITS
			2 COINS	3 CREDITS
SETTING #17	3 COINS	1 CREDIT	3 COINS	1 CREDIT
SETTING #18	4 COINS	1 CREDIT	4 COINS	1 CREDIT
SETTING #19	1 COIN	1 CREDIT	1 COIN	1 CREDIT
	2 COINS	2 CREDITS	2 COINS	2 CREDITS
	3 COINS	3 CREDITS	3 COINS	3 CREDITS
	4 COINS	5 CREDITS	4 COINS	5 CREDITS
SETTING #20	1 COIN	5 CREDITS	1 COIN	1 CREDIT
			2 COINS	2 CREDITS
			3 COINS	3 CREDITS
			4 COINS	5 CREDITS
SETTING #21	5 COINS	1 CREDIT	5 COINS	1 CREDIT
SETTING #22	1 COIN	2 CREDITS	3 COINS	1 CREDIT
			5 COINS	2 CREDITS
SETTING #23	2 COINS	1 CREDIT	2 COINS	1 CREDIT
	4 COINS	2 CREDITS	4 COINS	2 CREDITS
	5 COINS	3 CREDITS	5 COINS	3 CREDITS
SETTING #24	1 COIN	3 CREDIT	2 COINS	1 CREDIT
			4 COINS	2 CREDITS
			5 COINS	3 CREDITS
SETTING #25	1 COIN	1 CREDIT	1 COIN	1 CREDIT
	2 COINS	2 CREDITS	2 COINS	2 CREDITS
	3 COINS	3 CREDITS	3 COINS	3 CREDITS
	4 COINS	4 CREDITS	4 COINS	4 CREDITS
	5 COINS	6 CREDITS	5 COINS	6 CREDITS
SETTING #26	1 COIN	1 CREDIT	1 COIN	1 CREDIT
			2 COINS	2 CREDITS
			3 COINS	3 CREDITS
			4 COINS	4 CREDITS
			5 COINS	6 CREDITS
SETTING #27	FREE PLAY		FREE PLAY	

MANUAL SETTING

COIN ASSIGNMENTS (MANUAL SETTING)	
COIN TO CREDIT	1 COIN 1 CREDIT
BONUS ADDER	NO BONUS ADDER
COIN CHUTE #1 MULTIPLIER	1 COIN COUNTS AS 1 COIN
COIN CHUTE #2 MULTIPLIER	1 COIN COUNTS AS 1 COIN
→ EXIT	

SELECT WITH SERVICE BUTTON
AND PRESS TEST BUTTON

FIG. 9. 11b COIN ASSIGNMENTS

- COIN TO CREDIT Determines conversion coin/credit.
- BONUS ADDER This sets how many conversion coins should be inserted to obtain one SERVICE COIN.
- COIN CHUTE #X MULTIPLIER This sets how many inserted tokens one conversion coin represents.

TABLE 9.11 b MANUAL SETTING

COIN TO CREDIT	1 COIN	1 CREDIT
	2 COINS	1 CREDIT
	3 COINS	1 CREDIT
	4 COINS	1 CREDIT
	5 COINS	1 CREDIT
	6 COINS	1 CREDIT
	7 COINS	1 CREDIT
	8 COINS	1 CREDIT
	9 COINS	1 CREDIT

BONUS ADDER	NO BONUS ADDER	
	2 COINS	GIVE 1 EXTRA COIN
	3 COINS	GIVE 1 EXTRA COIN
	4 COINS	GIVE 1 EXTRA COIN
	5 COINS	GIVE 1 EXTRA COIN
	6 COINS	GIVE 1 EXTRA COIN
	7 COINS	GIVE 1 EXTRA COIN
	8 COINS	GIVE 1 EXTRA COIN
	9 COINS	GIVE 1 EXTRA COIN

COIN CHUTE MULTIPLIER	1 COIN COUNTS AS 1 COIN	
	1 COIN COUNTS AS 2 COINS	
	1 COIN COUNTS AS 3 COINS	
	1 COIN COUNTS AS 4 COINS	
	1 COIN COUNTS AS 5 COINS	
	1 COIN COUNTS AS 6 COINS	
	1 COIN COUNTS AS 7 COINS	
	1 COIN COUNTS AS 8 COINS	
	1 COIN COUNTS AS 9 COINS	

9-12 BOOKKEEPING

Selecting the **BOOKKEEPING** in the menu mode displays the bookkeeping data up to the present on the following 2 pages.

Press the **TEST** button again to proceed to the next page.

BOOKKEEPING PAGE 1/2	
COIN CHUTE #1	0
COIN CHUTE #2	0
TOTAL COINS	0
COIN CREDITS	0
SERVICE CREDITS	0
TOTAL CREDITS	0
NUMBER OF GAMES	0
TOTAL TIME	0D 0H 0M 0S
PLAY TIME	0D 0H 0M 0S
AVERAGE TIME	0H00M00S
LONGEST TIME	0H00M00S
SHORTEST TIME	0H00M00S
PRESS TEST BUTTON TO CONTINUE	

FIG. 9.12 a BOOKKEEPING (1/2)

BOOKKEEPING 2/2					
TIME HISTOGRAM		BEGINNER	BEGINNER	MEDIUM	EXPERT
COURSE		(DAY)	(NIGHT)		
-	1M29S	0	0	0	0
1M30S	- 1M44S	0	0	0	0
1M45S	- 1M59S	0	0	0	0
2M00S	- 2M14S	0	0	0	0
2M15S	- 2M29S	0	0	0	0
2M30S	- 2M44S	0	0	0	0
2M45S	- 2M59S	0	0	0	0
3M00S	- 3M14S	0	0	0	0
3M15S	- 3M29S	0	0	0	0
3M30S	-	0	0	0	0
PRESS TEST BUTTON TO EXIT					

FIG. 9.12 b BOOKKEEPING (2/2)

- **COIN CHUTE# *** Number of coins put in. As seen from the front of the cabinet, the right-hand side is #1 and the left-hand side is #2.
- **TOTAL COINS** Total number of coins inserted in each coin chute.
- **COIN CREDITS** Number of credits registered by inserting coins
- **SERVICE CREDITS** Credits registered by the **SERVICE** button
- **TOTAL CREDITS** Total number of credits (**COIN CREDITS** + **SERVICE CREDITS**)
- **TOTAL TIME** The total energized time.
- **TIME HISTOGRAM** By-playtime play frequency.

9-13 BACKUP DATA CLEAR

The contents of BOOKKEEPING can be cleared. When clearing the BOOKKEEPING contents, bring the arrow to "YES (CLEAR)" by using the Service button, and press the Test button. When clearing is finished, "COMPLETED" will be displayed and then the menu mode returns. Bring the arrow to "NO (CANCEL)" and press the Test button to have the Menu mode return on the screen without clearing the data. Note that this operation does not affect the contents of the game setting.

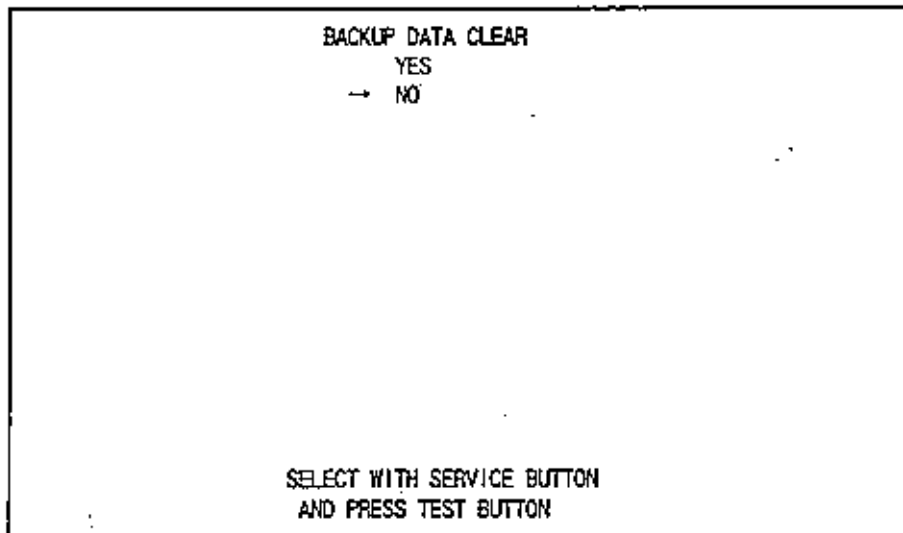

FIG. 9.13 BACKUP DATA CLEAR

10. HANDLE MECHA



- Be sure to turn power off before performing the work.
- This unit is a heavy item weighing approximately 22kg. and therefore, be very careful when performing the work.
- Immediately after the game is finished, the motor may still be very hot. When performing the removal work, wait until the motor cools off.

In the Test mode, if the Steering Wheel's V.R. variations are not within the allowable range, the V.R. installation position adjustments or V.R. replacement is needed. Also, be sure to apply greasing to the V.R. Gear portion once every 3 months.

10-1 REMOVING THE CONTROL PANEL

- ① Turn the power switch off.
- ① Remove a total of 4 Tamperproof Screws from both sides of the Control Panel's front part.
- ② Remove the 2 Tamperproof Screws from the underside of the Control Panel.
- ③ Wiring Connectors are connected inside the Control Panel. Carefully draw the Control Panel in the manner not to damage the wiring.
- ④ Disconnect the wiring connector.

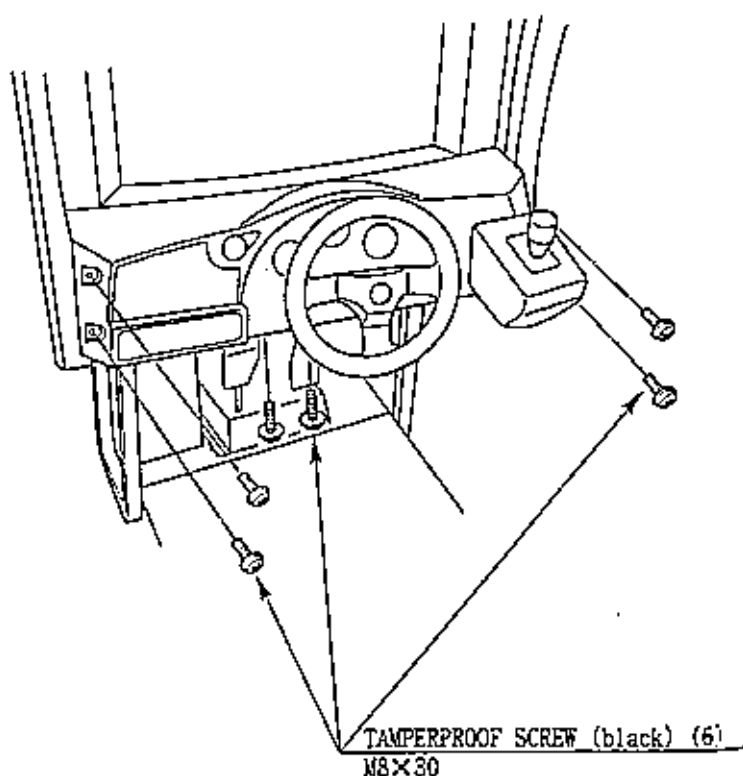

FIG. 10.1

10-2 REPLACING AND ADJUSTING THE HANDLE'S (STEERING WHEEL'S) V.R.



Never touch places other than those specified. Touching places not specified can cause electric shock and short circuit.



After the replacement or adjustment of the V.R., be sure to set the variable value of the V.R. in the Test Mode (refer to 9-9).

REPLACING THE VOLUME

- ① Turn off power.
- ② Disconnect the connector.
- ③ Take out the 2 screws which secure the Volume Bracket and remove the Volume Bracket.
- ④ Take out the 2 screws to remove the Volume Gear and replace the Volume.
- ⑤ After replacing the Volume, perform Volume setting in the Volume setting mode.

ADJUSTING THE VOLUME

- ① In the Test Mode, have the Volume value indicating screen displayed.
- ② Loosen the 2 screws which secure the Volume Bracket to disengage gear mesh.
- ③ With the Steering Wheel in the centering position, cause gears to be engaged in the manner so that the Volume Shaft is in the status shown as per FIG. 10.2.
- ④ Fasten the screws which secure the Volume Bracket.
- ⑤ Perform Volume setting as per the Volume Setting mode.

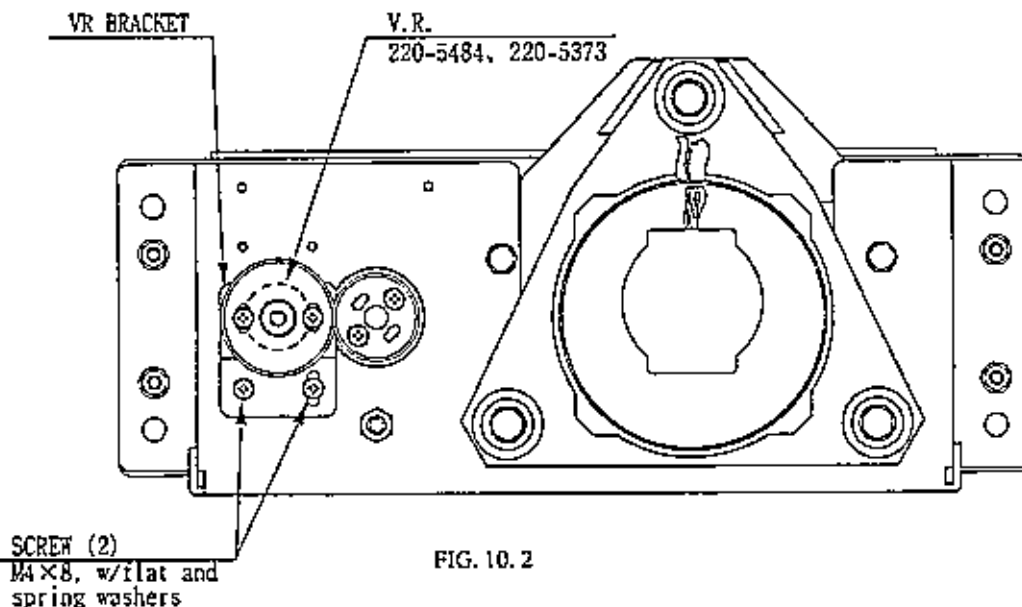

10-3 GREASING



Be sure to use the designated grease. Using undesignated grease can cause parts damage.

Apply greasing to the Volume gear mesh portion once every 3 months.
For spray greasing, use GREASE MATE (PART No. 090-0066).

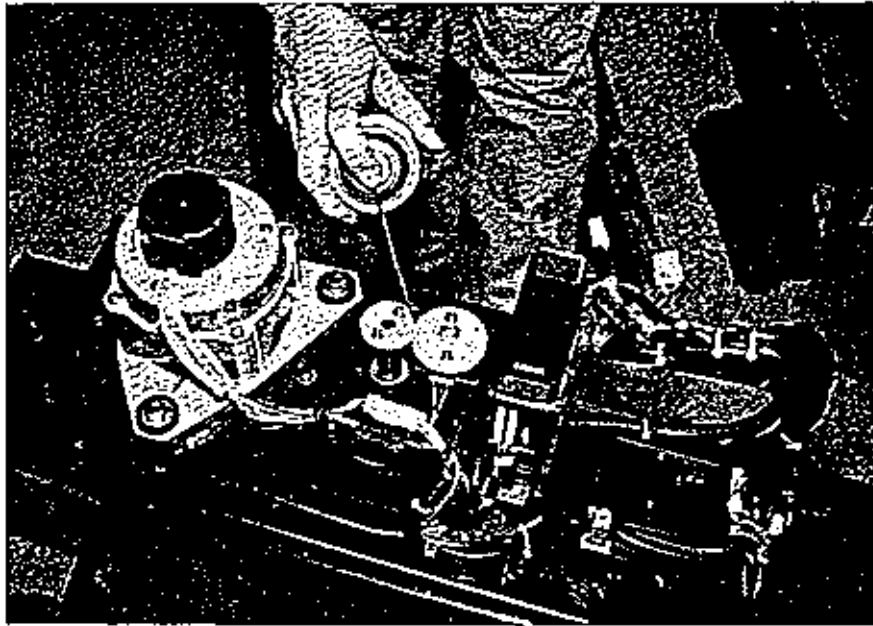

Photo 10.3

11. ACCELERATOR & BRAKE



- In order to prevent an electric shock and short circuit, be sure to turn power off before performing work by touching the interior parts of the product.
- Be careful so as not to damage wirings. Damaged wiring can cause an electric shock or short circuit accident.
- Do not touch places other than those specified. Touching places not specified can cause an electric shock or short circuit accident.

If Accel. and Brake operation is not satisfactory, adjustment of Volume installation position or Volume replacement is needed. Also, be sure to apply greasing to the gear mesh portion once every 3 months.

11-1 ADJUSTING AND REPLACING THE V.R.

The appropriate value of each V.R. is as follows.

	When released:		When stepped on:
ACCEL :	Under 30 H	↔	Over COH
BRAKE :	Under 30 H	↔	Over COH

Check Volume values in the Test Mode. (See Section 9.)

Since work is performed inside the energized cabinet, be very careful so as not to touch undesignated portions. Touching places not specified can cause electric shock or short circuit.

- ① Take out the 2 truss screws and remove the Front Cover from the Accel. & Brake Unit (FIG. 11.1 a).
- ② Loosen the screw which secure the Potentiobase, and adjust the Volume value by moving the Base. (FIG. 11.1 b)
- ③ Secure the Potentiobase.
- ④ Perform Volume setting in the Volume setting mode.

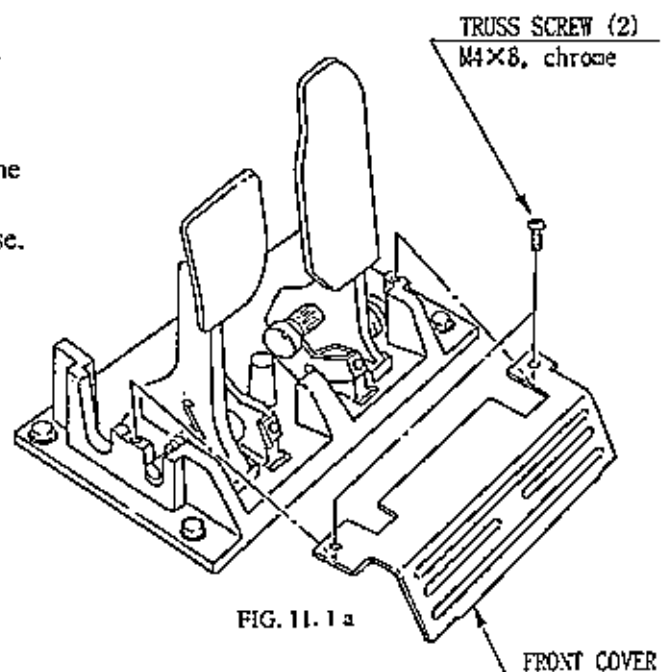
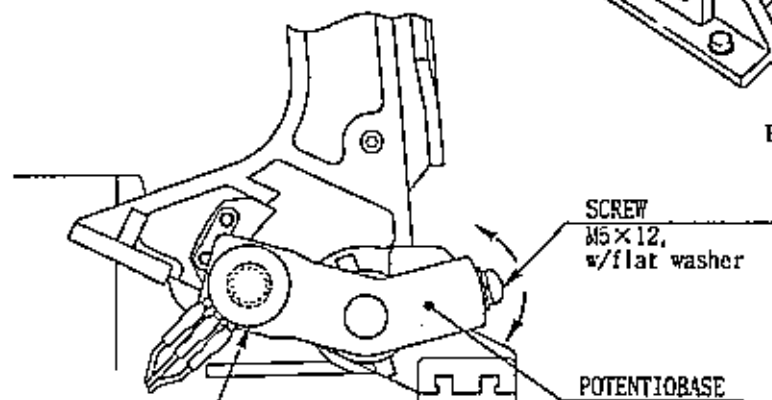

FIG. 11.1 a



V.R.
220-5373, 5484

FIG. 11.1 b

REPLACING THE VOLUME

- ① Turn the power off.
- ② Take out the 2 screws and remove the Potentiocover (FIG. 11. 1 c).
- ③ Disconnect the connector of the Volume to be replaced.
- ④ Remove the screw which secures the Potentiocover (FIG. 11. 1 b).
- ⑤ Remove the Potentiobase together with the Volume as is attached. (FIG. 11. 1. c)
- ⑥ Remove the Base and Gear to replace the Volume.
- ⑦ In the Test Mode, ensure that the Volume value is appropriate.

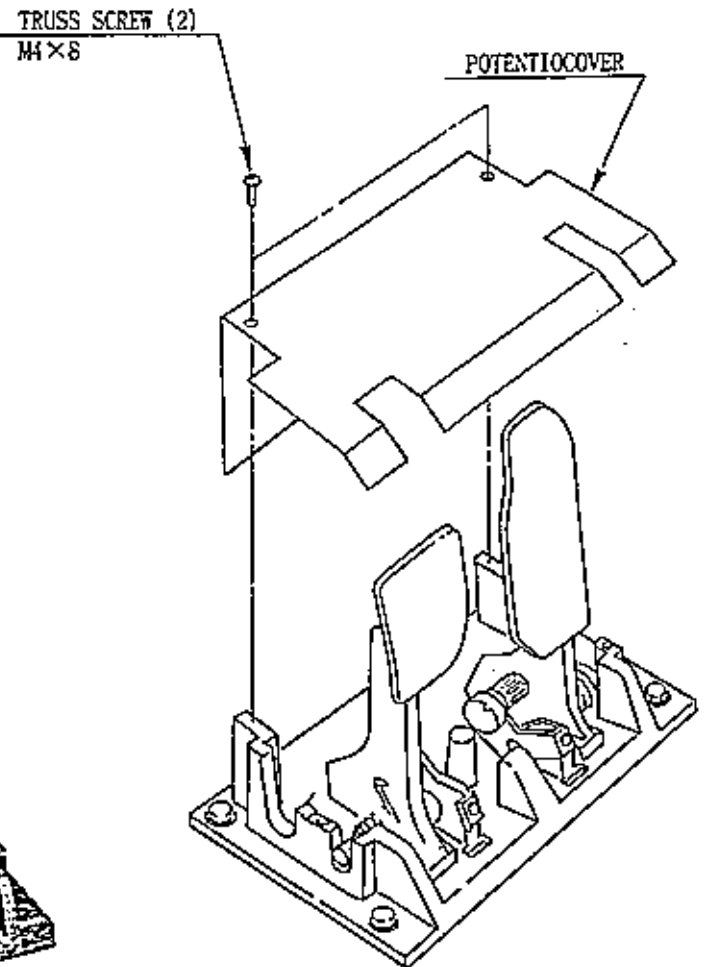
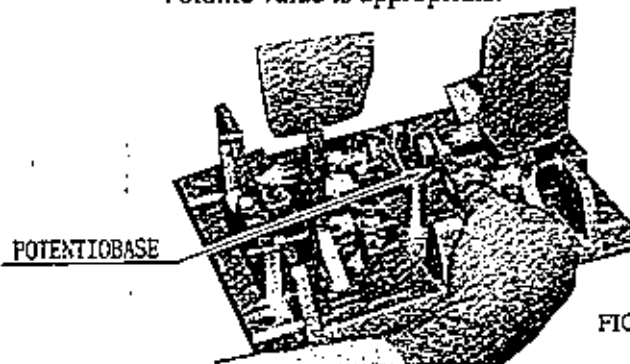

FIG. 11. 1 c

11-2 GREASING



Be sure to use the designated grease. Using undesignated grease can cause parts damage.

Once every 3 months, apply greasing to the Spring and Gear mesh portion. For spray greasing, use GREASE MATE (PART No. 090-0066).

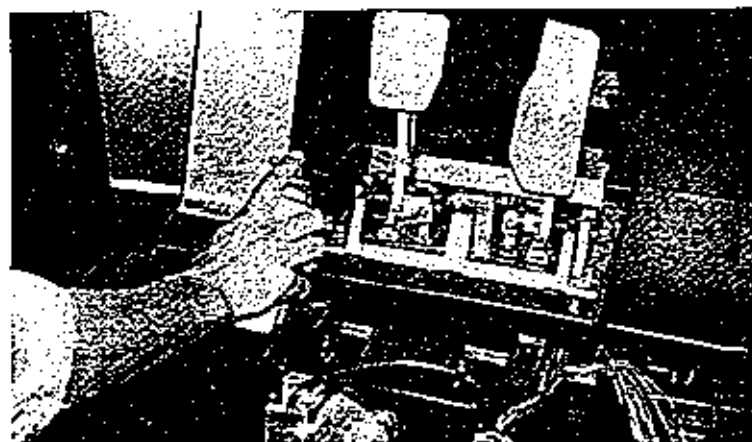

Photo 11.2

12. SHIFT LEVER



- In order to prevent an electric shock and short circuit, be sure to turn power off before performing work by touching the interior parts of the product.
- Be careful so as not to damage wirings. Damaged wiring can cause an electric shock or short circuit accident.
- Do not touch places other than those specified. Touching places not specified can cause an electric shock or short circuit accident.

If the Shift Lever operation is not satisfactory, remove the Shift Lever in the following procedure and replace the microswitch.

12-1 REMOVING THE SHIFT LEVER

- ① Turn the power off.
- ② Take off the 4 screws and remove **SHIFT COVER A**.
- ③ Take out the 4 **SPECIAL BOLTS** and pull the **SHIFT LEVER UNIT** upward by paying careful attention so as not to cause damage to the wiring.
- ④ Disconnect the 2 connectors to allow the unit to be removed.

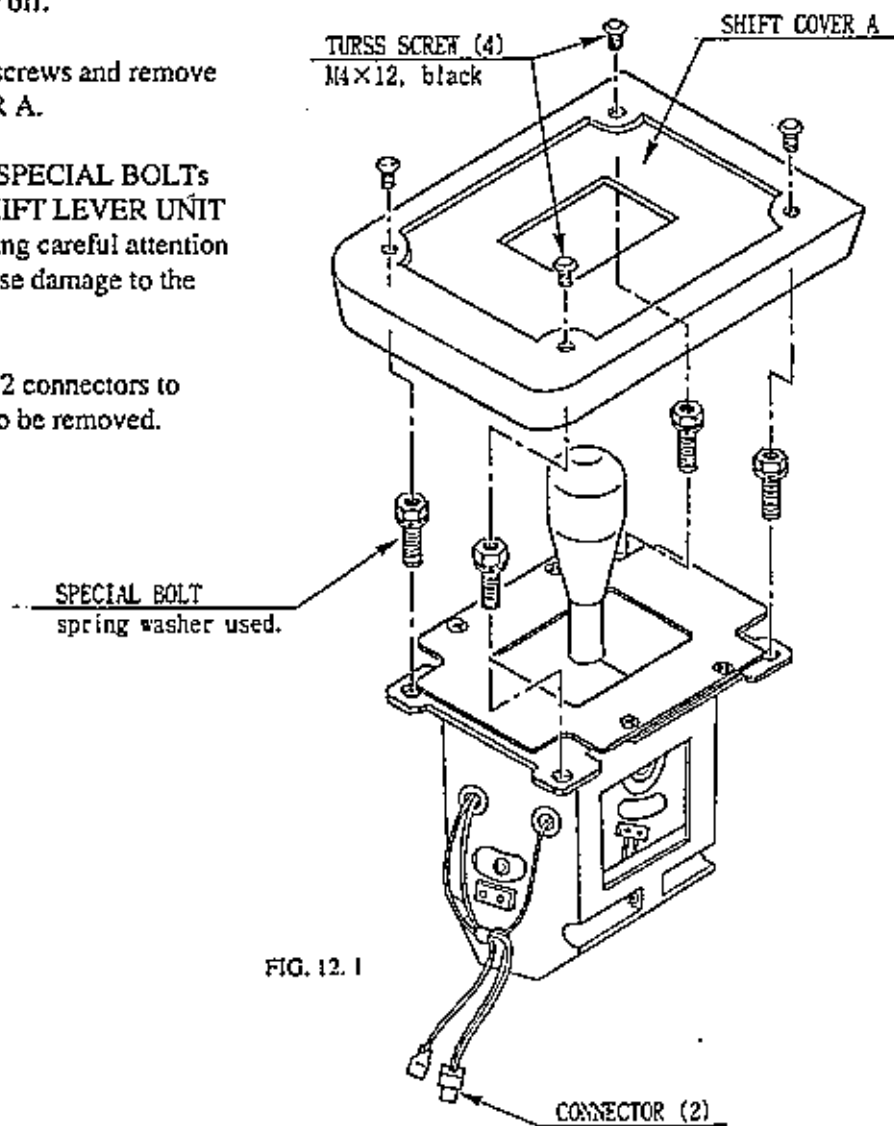

FIG. 12.1

12-2 SWITCH REPLACEMENT

Each Microswitch is secured with 2 screws. Remove the 2 screws and replace the Microswitch.

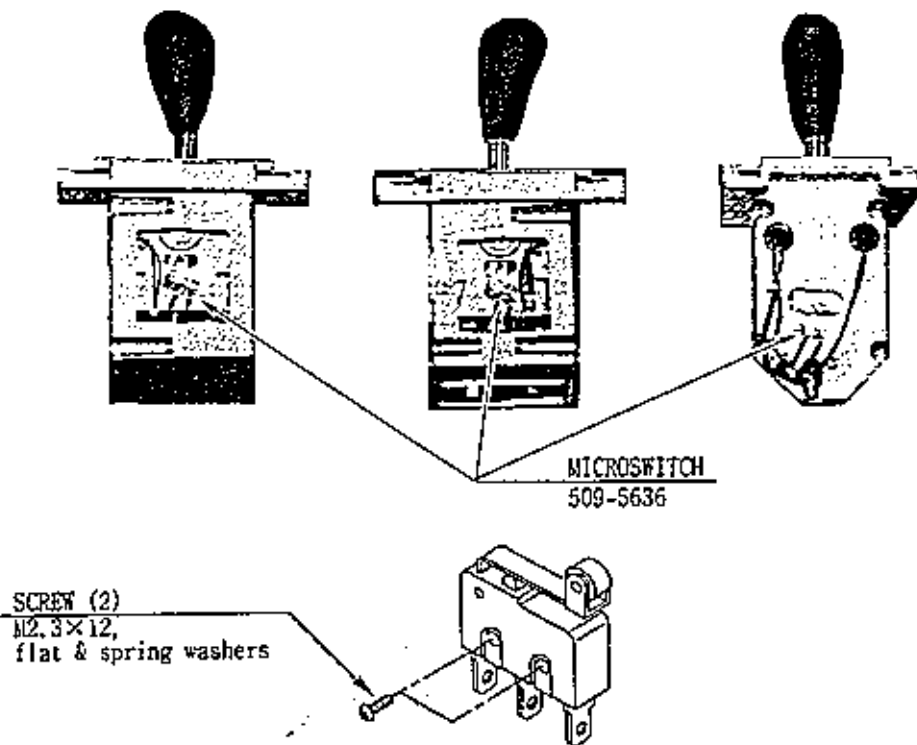

FIG. 12. 2

After replacing the Switch, check to see if the switch is inputted as per Shift Lever operation in the Test Mode.

13. COIN SELECTOR

HANDLING THE COIN JAM

If the coin is not rejected when the REJECT button is pressed, open the coin chute door and open the selector gate. After removing the jammed coin, put a normal coin in and check to see that the selector correctly functions.

CLEANING THE COIN SELECTOR

The coin selector should be cleaned once every 3 months. When cleaning, follow the procedure below:

- ① Turn the power for the machine OFF. Open the coin chute door.
- ② Open the gate and dust off by using a soft brush (made of wool, etc.).
- ③ Remove and clean smears by using a soft cloth dipped in water or diluted chemical detergent and then squeezed dry.
- ④ Remove the CRADLE.

When removing the retaining ring (E ring), be very careful so as not to bend the shaft.

- ⑤ Remove stain from the shaft and pillow portions by wiping off with a soft cloth, etc.
- ⑥ After wiping off as per ⑤ above, further apply a dry cloth, etc. to cause the coin selector to dry completely.



- Never apply machine oil, etc. to the Coin Selector.
- After cleaning the Coin Selector, insert a regular coin in the normal working status and ensure that the Selector correctly functions.

COIN INSERTION TEST

Once every month, when performing the Coin SW Test, simultaneously check the following:

- Does the Coin Meter count satisfactorily?
- Does the coin drop into the Cashbox correctly?
- Is the coin rejected when inserted while keeping the Reject Button pressed down?

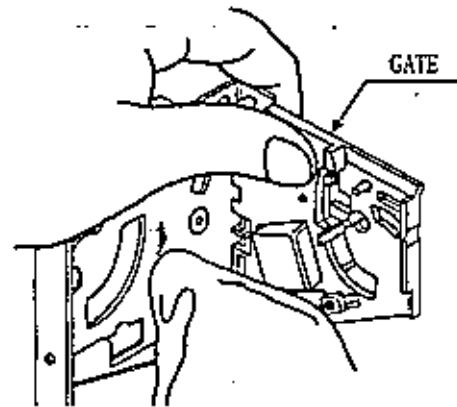

FIG. 13 a

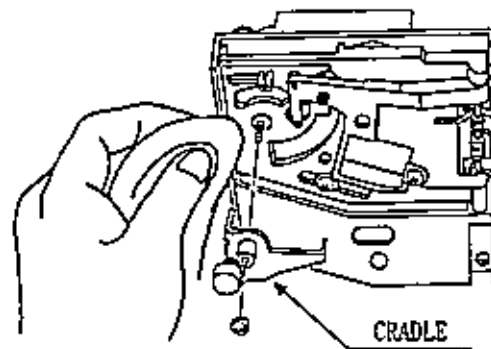

FIG. 13 b

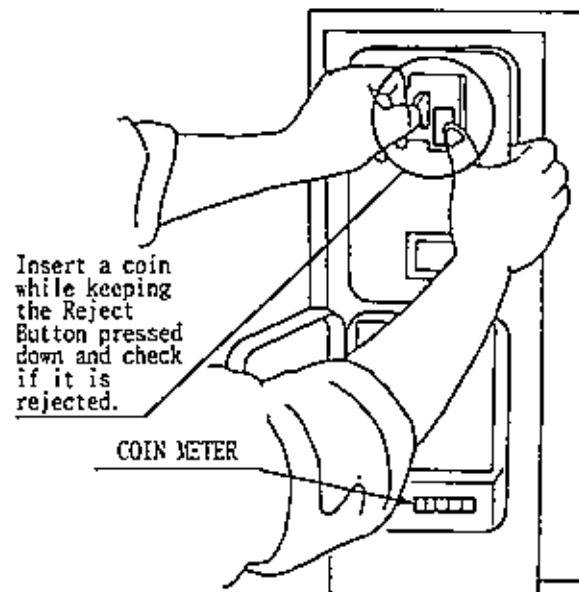

FIG. 13 c

14. MONITOR

14-1 CAUTIONS AND WARNINGS CONCERNING THE SAFETY FOR HANDLING THE MONITORS

Before handling the monitors, be sure to read the following explanations and comply with the caution/warning instructions given below. Note that the caution/warning symbol marks and letters are used in the instructions.



Indicates that handling the monitors erroneously by disregarding this warning may cause a potentially hazardous situation, which could result in death or serious injury.



Indicates that handling the monitors by disregarding this caution may cause a potentially hazardous situation, which could result in personal injury and or material damage.



Indicates that access to a specific part of the equipment is forbidden.



Indicates the instruction to disconnect a power connector or to unplug.



- When performing such work as installing and removing the monitor, inserting and disconnecting the external connectors to and from monitor interior and the monitor, be sure to disconnect the power connector (plug) before starting the work. Proceeding the work without following this instruction can cause electric shock or malfunctioning.
- Using the monitor by converting it without obtaining a prior permission is not allowed. SEGA shall not be liable for any malfunctioning and accident caused by said conversion.



- **Primary side and Secondary side**
The monitor's circuit which is divided into the Primary side and Secondary side, is electrically isolated. Do not touch the primary side, or do not touch both the primary side and the secondary side simultaneously. Failing to observe the instruction can cause electric shock and this is very dangerous. When making monitor adjustments, use a non-conductive driver and make adjustment without touching any part other than the Adjustment V. R. and knob. Also, be sure not to cause a short-circuit to the Primary side and Secondary side. If short-circuited, it can cause electric shock or malfunctioning, which is very dangerous.

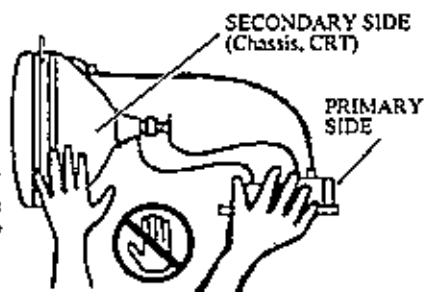

- **High-tension Voltage**

Some of the parts inside monitor are subject to high-tension voltage in excess of 20,000 volts and very dangerous. Therefore, do not touch the monitor interior. Should soldering & paper wastes, etc. be mixed in the monitor interior, turn the power off so as not to cause malfunctioning or fire hazard.

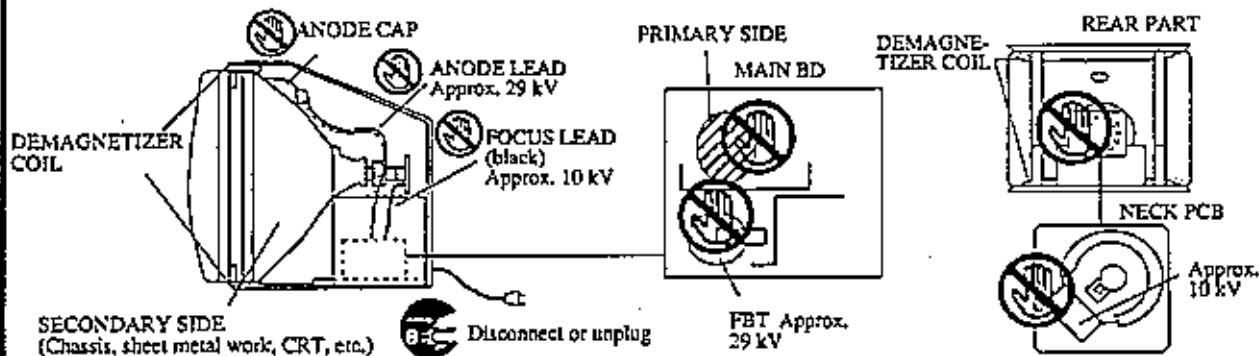

- **Connecting the CRT and PCB**

For combining the CRT and PCB, use the specified part No. to maintain the status of adjustments made at the factory. The anode of the CRT itself will be accumulatively charged as time elapses, generating high-tension voltage which is very dangerous. The monitor should be used with the Chassis, CRT and PCB assembled. When repair, etc. is required at the time of malfunctioning, be sure to send it in an "as is assembled" condition. If these are disassembled, what's charged to said high tension voltage can be discharged, causing a very hazardous situation. Therefore, under no circumstances should it be disassembled.



- **Static Electricity**
Touching the CRT surface sometimes causes you to slightly feel electricity. This is because the CRT surfaces are subject to static and will not adversely affect the human body.
- **Installation and removal**
Ensure that the Magnetizer Coil, FBT (Fly-Back Transformer), Anode Lead and Focus Lead are not positioned close to the sheet metal work's sharp edges, etc. and avoid damaging the insulated portions so as not to cause electric shock and malfunctioning. (For the name of parts, refer to the above Figures).



CAUTION!

For the purpose of static prevention, special coating is applied to the CRT face of this product. To protect the coating, pay attention to the following points. Damaging the coating film can cause electric shock to the customers. For the caution to be heeded when cleaning, refer to the Section of Periodic Inspection Table.

- Do not apply or rub with a hard item (a rod with pointed edge, pen, etc.) to or on the CRT surfaces.
- Avoid applying stickers, seals, etc. on the CRT face.
- Do not remove aluminum foils from the CRT corners. Removing the aluminum foils can cause static prevention effects to be lowered.

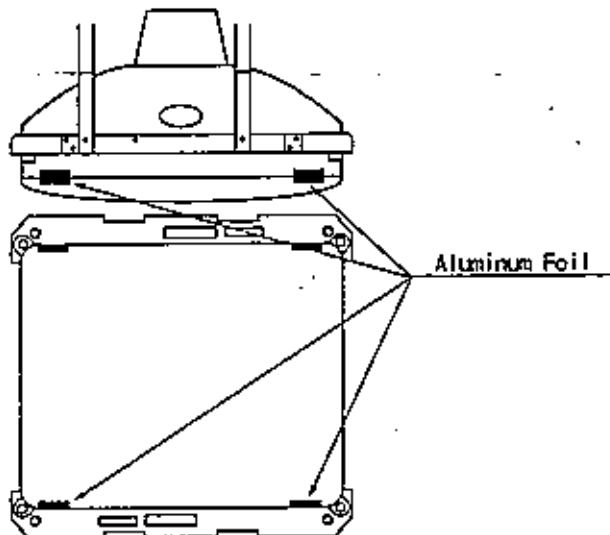

14-2 CAUTIONS TO BE HEEDED WHEN CLEANING THE CRT SURFACES



CAUTION!

Static preventive coating is applied to the CRT surfaces. When cleaning, pay attention to the following points. Peeling off of static preventive coat can cause electric shock.

- Remove smears by using a dry, soft cloth (flannels, etc.). Do not use a coarse gauze, etc.
- For smear removing solvent, alcohol (ethanol) is recommended. When using chemical detergent, be sure to follow instructions below:
 - Dilute chemical detergent with water and dip a soft cloth in and then thoroughly wring it to wipe smears off.
 - Do not use a chemical detergent containing an abradant, powder or bleaching agent.
 - Do not use alkaline chemical detergents such as "glass cleaner" available on the market or solvents such as thinner, etc.
- Do not rub or scratch the CRT face with hard items such as brushes, scrub brush, etc.

Clean the CRT surfaces once a week. When cleaning, pay attention to the above caution so that the antistatic coating will not come off.



- Monitor adjustments have been made at the time of shipment. Therefore, do not make further adjustment without a justifiable reason. Adjusting the monitor which contains high tension parts is a dangerous work. Also, an erroneous adjustment can cause deviated synchronization and projection fault, resulting in malfunctioning.
- When making adjustment, utilize a resinous Alignment Screwdriver. Servicing with bare hand or using conductive tools can cause electric shock.

To make monitor adjustment, take off the 2 Truss Screws from CRT ADJUST PANEL portion. The Adjustment BD appears when the screws are removed. There are 2 Monitor Manufacturers (NANAO and SANWA). The Adjustment Control Layout differs depending on the specific Maker. When performing the adjustment, check the Maker by referring to the following.

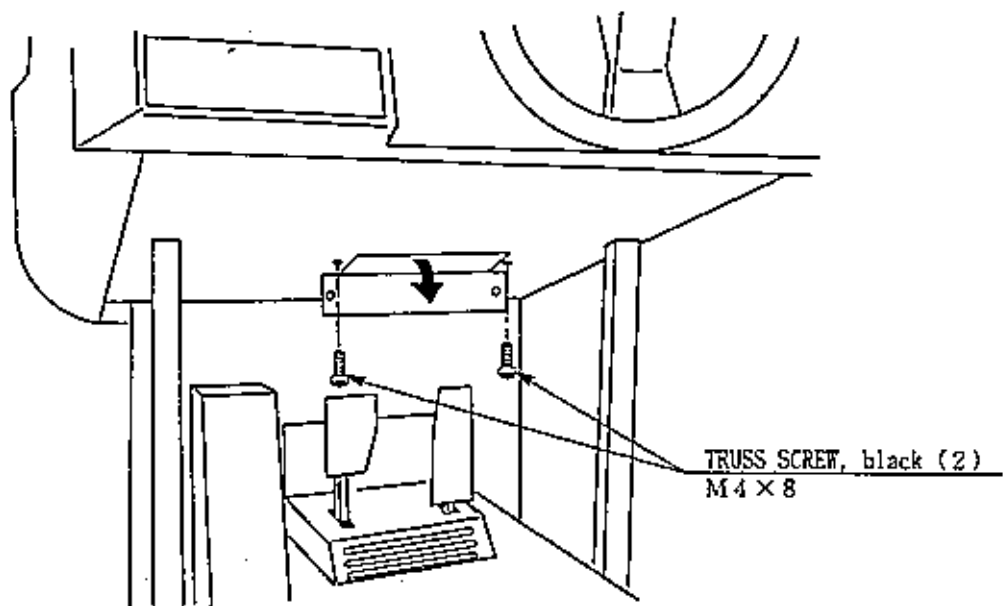
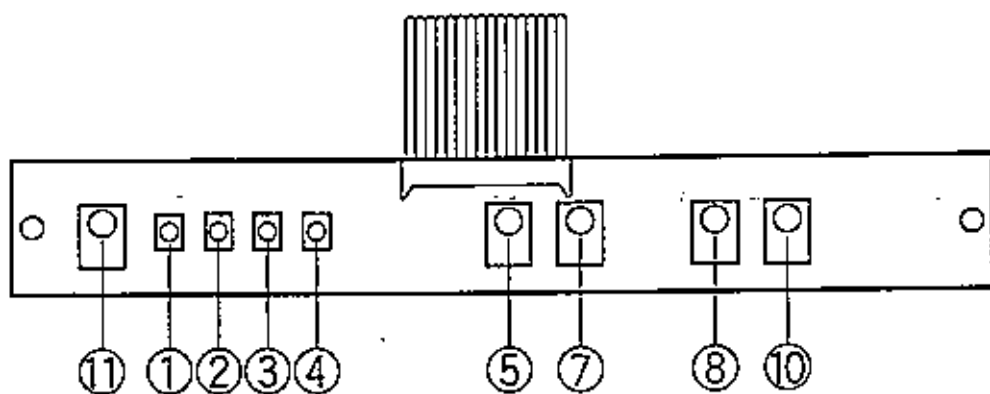
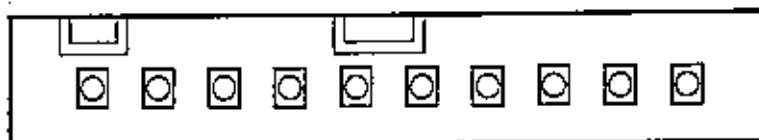

Fig. 14.3

NANAO monitor: 2 0 0 - 5 2 4 2 - 2 4 - 0 4 (24K mode)



SANWA monitor: 2 0 0 - 5 2 4 3 - 2 4 (24K mode)



①	②	③	④	⑤	⑥	⑦	⑧	⑨	⑩
R GAIN	G GAIN	B GAIN	BRIGHT	H SIZE	H HOLD	H POSI	V SIZE	V HOLD	V POSI

- ① R-GAIN.....
- ② G-GAIN Controls colors.
- ③ B-GAIN.....
- ④ BRIGHT Controls screen brightness.
- ⑤ H. SIZE Controls horizontal screen size.
- ⑥ H. HOLD Provides horizontal synchronization, i.e., controls right/left hold.
- ⑦ H. POSI Controls horizontal display position on screen.
- ⑧ V. SIZE Controls vertical screen size.
- ⑨ V. HOLD Provides vertical synchronization, i.e., controls up-down hold.
- ⑩ V. POSI Controls vertical display position on screen.
- ⑪ CONTRAST.... Controls color contrast. (Only applies to Nanao.)

15. REPLACEMENT OF FLUORESCENT LAMP



WARNING!

- When performing the work, be sure to turn power off. Working with power on can cause an electric shock or short circuit accident.
- The Fluorescent Lamp, when it gets hot, can cause burns. Be very careful when replacing the Fluorescent Lamp.



CAUTION!

To perform work safely and securely, be sure to prepare a step which is in a secure and stable condition. Not using a step or using an unstable step can cause a violent falling down accidents.

15-1 REPLACING THE FLUORESCENT LAMP

- ① Remove the 3 screws which secure the upper sash of the Billboard's upper part.
- ② pull out the Billboard upward to replace the Fluorescent Lamp (40W).

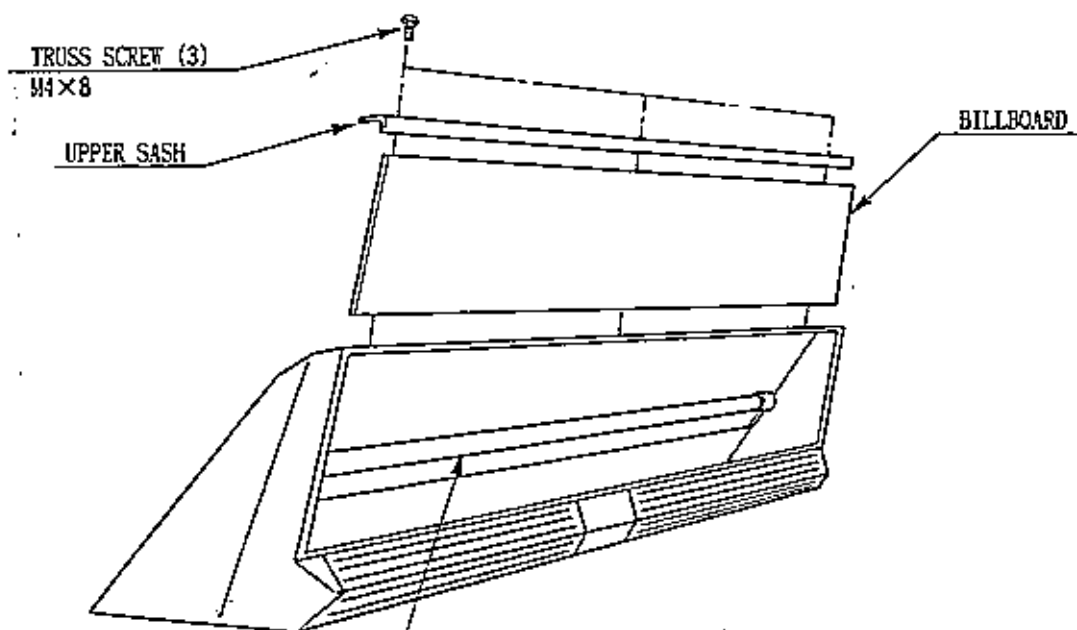

FLUORESCENT LAMP 40W: 390-5251-40-01
GLOW LAMP: 390-5638-4P

FIG. 15.1

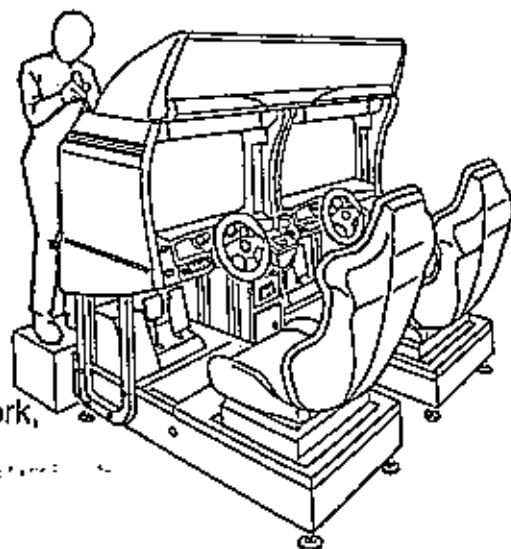

When performing work,
prepare a step.

15-2 REPLACING THE LEADER LAMP

Open the Lid and take out the 2 screws to replace the Leader Lamp.

- ① Take out the 3 screws to open the Lid.
- ② Disconnect the connector.
- ③ Take out the 2 screws to remove the Holder.
- ④ Remove the Cathode Tube to replace the Leader Lamp.

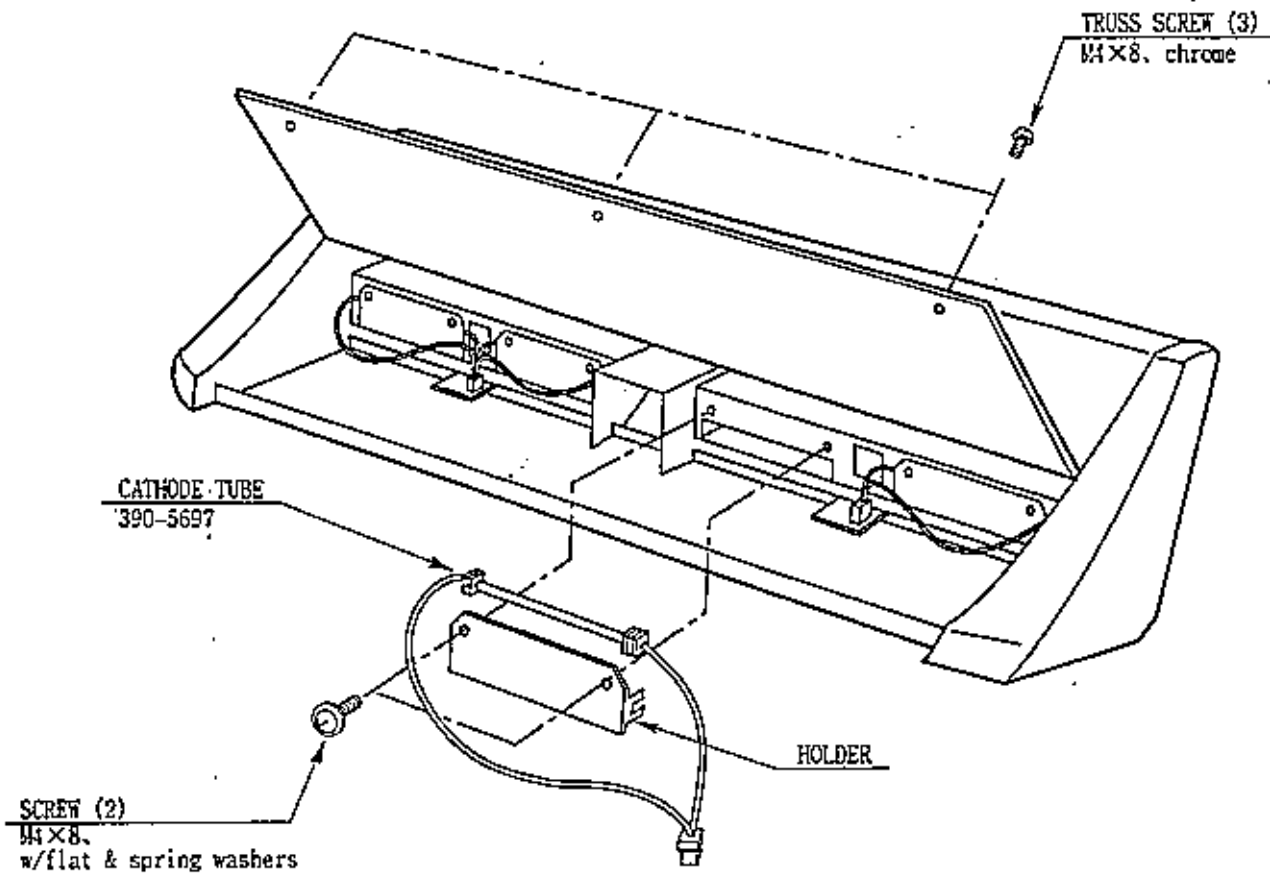
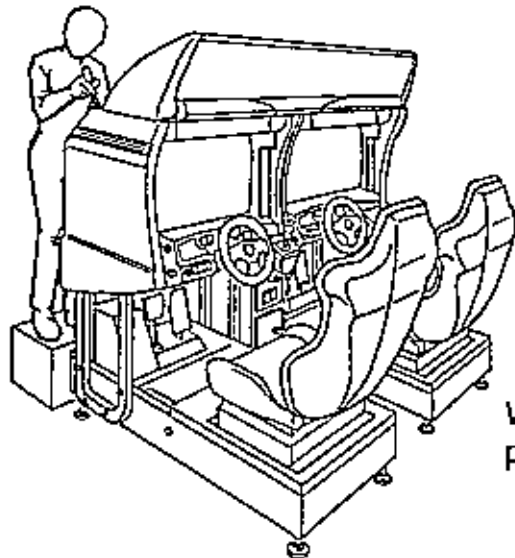

FIG. 15.2



When performing work,
prepare a step.

16. PERIODIC INSPECTION TABLE

The items listed below require periodic check and maintenance to retain the performance of this machine and to ensure safe business operation.



- Be sure to check once a year to see if Power Cords are damaged, the plug is securely inserted, dust is accumulated between the Socket Outlet and the Power Plug, etc. Using the product with dust as is accumulated can cause a fire or electric shock.
- Periodically once a year, request the place of contact herein stated or the Distributor, etc. where the product was purchased from, as regards the interior cleaning. Using the product with dust as is accumulated in the interior without cleaning can cause a fire or accident. Note that cleaning the interior parts can be performed on a pay-basis.

TABLE 16

	Item	Interval	Reference
HANDLE MECHA	Check lamp.	Monthly	9
	Check VOLUME VALUE.	Monthly	9, 10-2
	Check ADJUST GEAR engagement.	Trimonthly	10-2
	Greasing of GEAR.	Trimonthly	10-3
ACCEL. & BRAKE	Check VOLUME value.	Monthly	6, 9
	Check ADJUST GEAR engagement.	Trimonthly	11-1
	Gear and Spring portion greasing.	Trimonthly	11-2
SHIFT LEVER	Check SW.	Monthly	6, 9
COIN CHUTE TOWER	Check COIN SW.	Monthly	9
	Coin insertion test.	Monthly	13
	Cleaning of COIN SELECTOR.	Trimonthly	13
MONITOR	Check adjustments.	Monthly	6, 9, 14
SEAT	Antistatic measures	Bimonthly	5
	Applying grease to Seat Rail	Trimonthly	Next page (FIG.16)
GAME BD	MEMORY TEST.	Monthly	9
	Check settings.	Monthly	9
Cabinet surfaces	Cleaning	As occasion arises.	Next page
INTERIOR	Cleaning	Annually	See above.
POWER SUPPLY PLUG	Inspection and cleaning		

SEAT (Greasing to Seat Rail Portion)

Move the Seat to the rearmost portion and apply spray greasing to the portion shown at the right once every 3 months by using NOK KLUBER L60 or GREASE MATE SEGA PART No. 090-0066. After greasing, move the Seat a few times forward and backward so as to allow the grease to be applied all over uniformly. Be sure to wipe grease which attaches to the surfaces of the PROTECT RUBBER on the Seat Rail, or any excess grease.

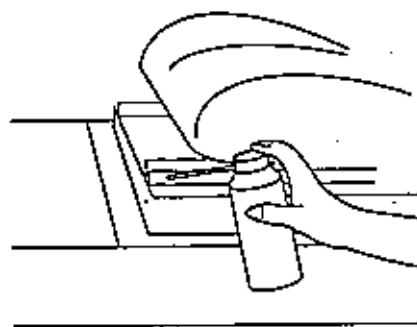

Fig. 16

CLEANING THE CABINET SURFACES

When the cabinet surfaces are badly soiled, remove stains with a soft cloth dipped in water or diluted (with water) chemical detergent and squeezed dry. To avoid damaging surface finish, do not use such solvents as thinner, benzene, etc. other than ethyl alcohol, or abrasives, bleaching agent and chemical dustcloth.

17. TROUBLESHOOTING

In case a problem occurs, first check wiring connector connections.

TABLE 17 a

PROBLEMS	CAUSE	COUNTERMEASURES
When the main SW is turned ON, the machine is not activated.	The power is not ON.	Firmly insert the plug into the outlet.
	Incorrect power source/voltage.	Make sure that the power supply/voltage are correct.
	AC UNIT CIRCUIT PROTECTOR functioned due to instantaneous overcurrent.	First, remove the cause of overcurrent and reinstate the circuit protector to its original status (refer to Sec. 6).
	The Connect BD Fuse is blown due to momentary overload.	Replace fuse (see FIG. 17).
The color of image on MONITOR screen is incorrect.	Incorrect monitor adjustment.	Make appropriate adjustments (see Sec. 14).
The on-screen image of the monitor sways and or shrinks.	The power source and voltage are not correct.	Make sure that the power supply and voltage are correct.
Sound is not emitted.	Sound volume adjustment is not correct.	Adjust the SWITCH UNIT's sound adjustment volume (control) (see Sec. 9).
	Malfunctioning BD. and Amp.	Perform Sound Test to check it (see Sec. 9).
	Connector connection is incorrect.	Check connector connection from Base to Speaker.

TABLE 17 b

PROBLEMS	CAUSE	COUNTERMEASURES
Operation of Accel. and Brake Pedals are not satisfactory.	V.R. position deviated.	Adjust V.R. value in the test mode (see Sec. 9).
	V.R. malfunctioning.	Replace the V.R. (see Sec. 11).
	ADJUST GEAR's engagement is not correct.	Adjust the engagement of ADJUST GEAR (see Sec. 11).
SHIFT LEVER doesn't operate satisfactorily.	Switch malfunctioning.	Replace the Switch (see Sec. 12).
Steering Wheel reaction strength is incorrect. Deviation of Center.	Power ON check not performed correctly.	Turn off power and then turn it back on again. Complete the power on check.
	V.R. position deviated.	Adjust V. R. value in the test mode (see Sec. 9).
	V.R. malfunctioning.	Replace V.R. (see Sec. 10).
Steering Wheel reaction strength is insufficient.	Reaction Mecha's secular change.	Change Drive Control BD DIP SW setting (see Sec. 18).
No Steering Wheel Reaction.	Connector Connection is incorrect.	Check connector connection from Base to Handle.
	The Motor Drive BD fuse is blown due to momentary overload.	Replace the Motor Drive BD Fuse (see Sec. 17).
Fluorescent lamp doesn't light up.	Fluorescent lamp needs replacement.	Replace the fluorescent lamp (see Sec. 15).
	The connector is disconnected.	Check connector connections in the billboard case (see Sec. 6).
The LEADER lamp does not light up.	Cathode Tube needs replacement.	Replace the Cathode Tube (see Sec. 15).
	The connector is disconnected.	Check connector connections in the billboard case (see Sec. 6).
Interactive play is not possible.	Communication cable is disconnected.	Connect the cable.
	Cable connections are not correct.	Connect the cable correctly (see Sec. 20).
	Settings for communication play are not correct.	Ensure that GAME ASSIGNMENTS settings are correct (see Sec. 9).

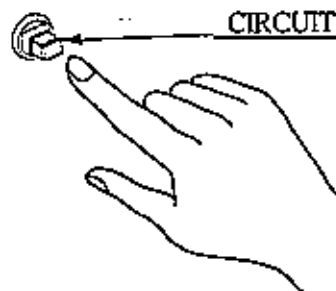

CIRCUIT PROTECTOR

Functions due to the activation of bimetal . . .
To restore the function, wait for approximately one minute or longer until the bimetal cools off.

REPLACEMENT AND ADJUSTMENT OF FUSE



- In order to prevent an electric shock, be sure to turn power off before performing work by touching the interior parts of the product.
- Be careful so as not to damage wirings. Damaged wiring can cause an electric shock or short circuit accident.
- Be sure to use fuses meeting specified rating: Using fuses exceeding the specified rating can cause a fire or electric shock.
- After eliminating the cause of the fuse blowing, replace the fuse. Depending on the cause of fuse blowing, continued use with the fuse as is blown can cause generation of heat resulting in a fire.

Incline the Seat and remove Base Lid F to view the Base interior. The composition of the Base interior is as shown below. (See Section 18-1). There is a fuse on each of the Connect BD. and Motor Drive BD. When replacing the fuse, be sure to use the specified one.

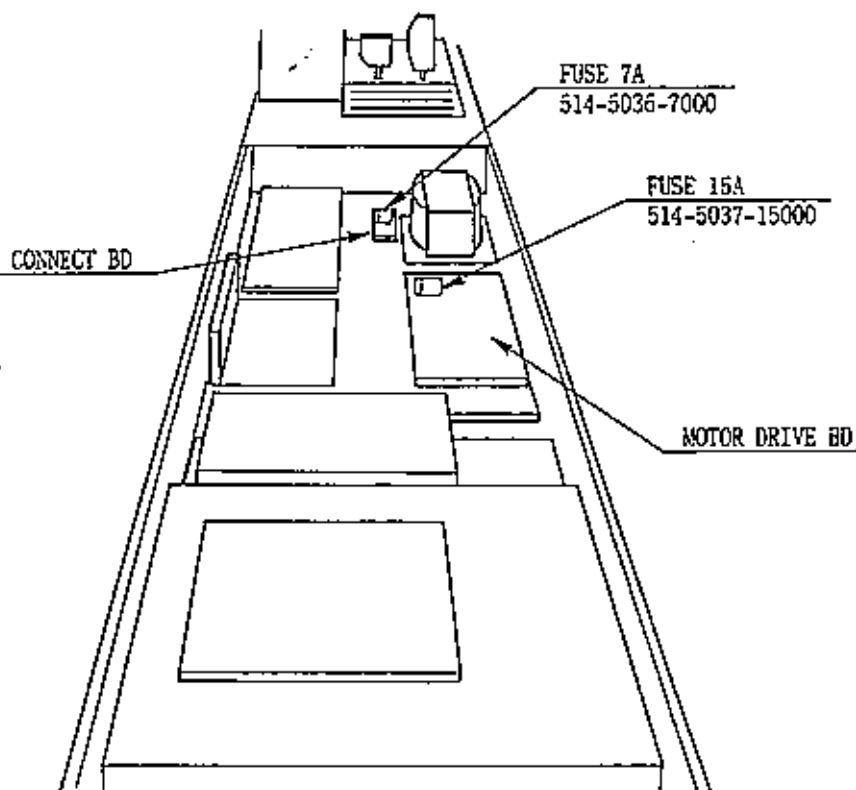

FIG. 17

18. GAME BOARD



WARNING!

- In order to prevent an electric shock, be sure to turn power off before performing work by touching the interior parts of the product.
- Be careful so as not to damage wirings. Damaged wiring can cause an electric shock or short circuit accident.



CAUTION!

Do not expose the Game BD, etc. without a good reason. In this product, setting changes are made during the test mode. The Game BD need not be operated. Use the Game BD, etc. as is with the same setting made at the time of shipment.

18-1 REMOVING THE BOARD

To replace the IC BD (such as Game BD, Drive BD, etc.), or to change DIP SW settings, take out the IC BD by using the following procedure:

- ① Turn the MAIN SW off.
- ② Unlock and take off the 2 truss screws from the side of the base as shown.
- ③ Turn the knob to unlock. The seat can be inclined in the direction shown. When inclining the seat, be careful so as not to damage the seat parts. Carefully cause the backrest portion of the seat to come into contact with the floor.
If the floor has hard surfaces, protect the seat from damage by using a cloth, etc. on the floor surfaces.
- ④ Disconnect all of the connectors connected to the Sound BD on the Case Lid.
- ⑤ Take off the 3 screws to remove the case lid. The Game Board is contained in the Shield Case.
- ⑥ Take off a total of 4 screws from both sides with the seat being in an inclined state and remove BASE LID F. Removing Base Lid F allows ELEC BASE to be viewed.

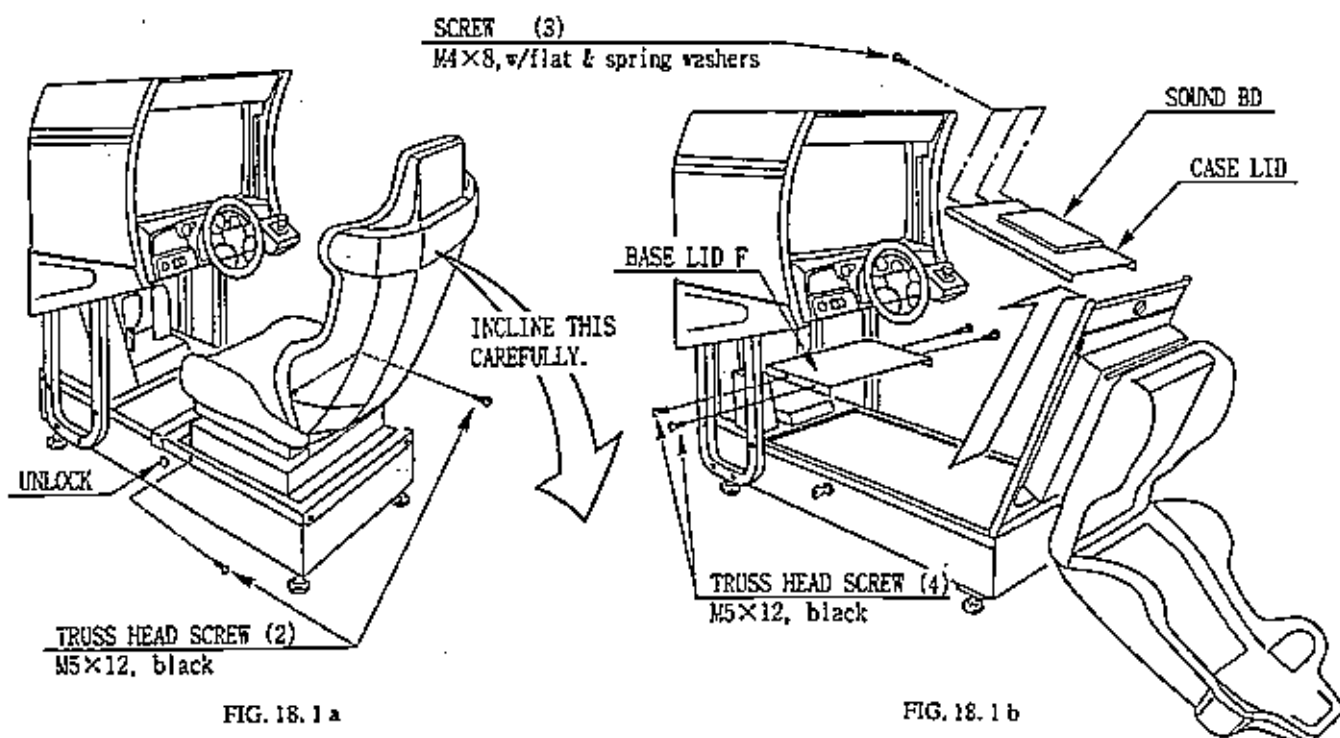

18-2 COMPOSITION OF GAME BOARD
 GAME BD SPG FOR COMMUNICATION

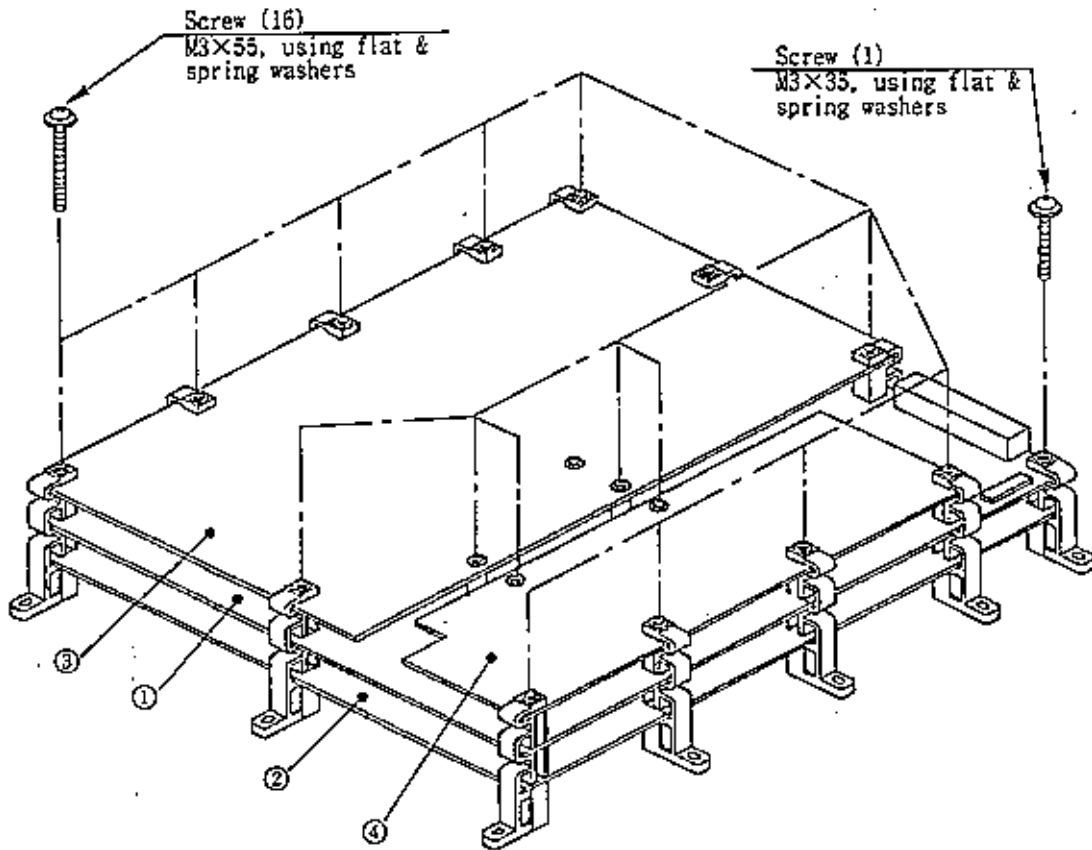

FIG. 18.2

No.	PART No	DESCRIPTION	NOTE
①	837-12874	MODEL3 STEP 1.5 CPU BOARD	
②	837-12875	MODEL3 STEP 1.5 VIDEO BOARD	
③	834-13042	ROM BD SPG FOR COMMUNICATION	OTHERS
	834-13072	ROM BD SPG COMM AUS	AUSTRALIA
④	837-11861	MODEL3 COMM BD COM	

18-3 ERROR DISPLAY (DRIVE CONTROL BOARD)



- Be careful so as not to damage wirings. Damaged wiring can cause an electric shock or short circuit accident.
- Do not touch places other than those specified. Touching places not specified can cause an electric shock or short circuit accident.

If an irregularity occurs in the Drive Control Board, etc., the ERROR message is shown on the screen and the 7-SEG display on the Drive Control BD. Take countermeasures in the manner corresponding to the ERROR message. Note that even at the time of error occurrence, game play is possible without Steering Wheel reaction.

Among the ERROR display as per Table 3, each of Er 01, 02, 20 and 22 is displayed if an irregularity is found during initialization setting movements when power is turned on and at the time the Test Mode is finished.

From among error displays as per Table 1 8. 3, Er 23, 24, and 25 indicate On-Board 7-SEG error display when an irregularity is found during game and ADVERTISE mode. If an irregularity is found during game, game play can be continued without Steering Wheel reaction.

Table 18.3 ERROR DISPLAY

On-screen ERROR display	7-SEG display on Drive Control BD.	ERROR	CAUSE/COUNTERMEASURES
DRIVE BOARD ERROR is displayed for 5 seconds before displaying ADVERTISE mode after initialization setting movement.	Er 01	ROM ERROR	Malfunctioning of Drive Control Board. Replace Drive Control Board.
	Er 02	RAM ERROR	
	Er 20	Initialization setting irregularity of motor	Irregularity during initialization setting movement. Finish initialization setting movement by turning power off and then on. Note that when ERROR is displayed, the malfunctioning relates to the Motor System (Motor, Drive Control BD which controls the Motor, Drive BD., wirings in between, etc.)
No image display on the screen.	Er 22	Steering Wheel's centering error	Malfunctioning during initial setting movement. Finish initialization setting movement by turning power off and then on. Note that when ERROR is displayed, the malfunctioning relates to the Steering Wheel Volume system.
	Er 23	ERROR of the Encoder incorporated in the motor.	Malfunctioning which occurs during operation. First turn the power off and after 10 min., turn it back on again. Note that when this Error is displayed, the malfunctioning relates to the Motor System.
	Er 24	Overcurrent ERROR	
	Er 25	Overheat Overload	

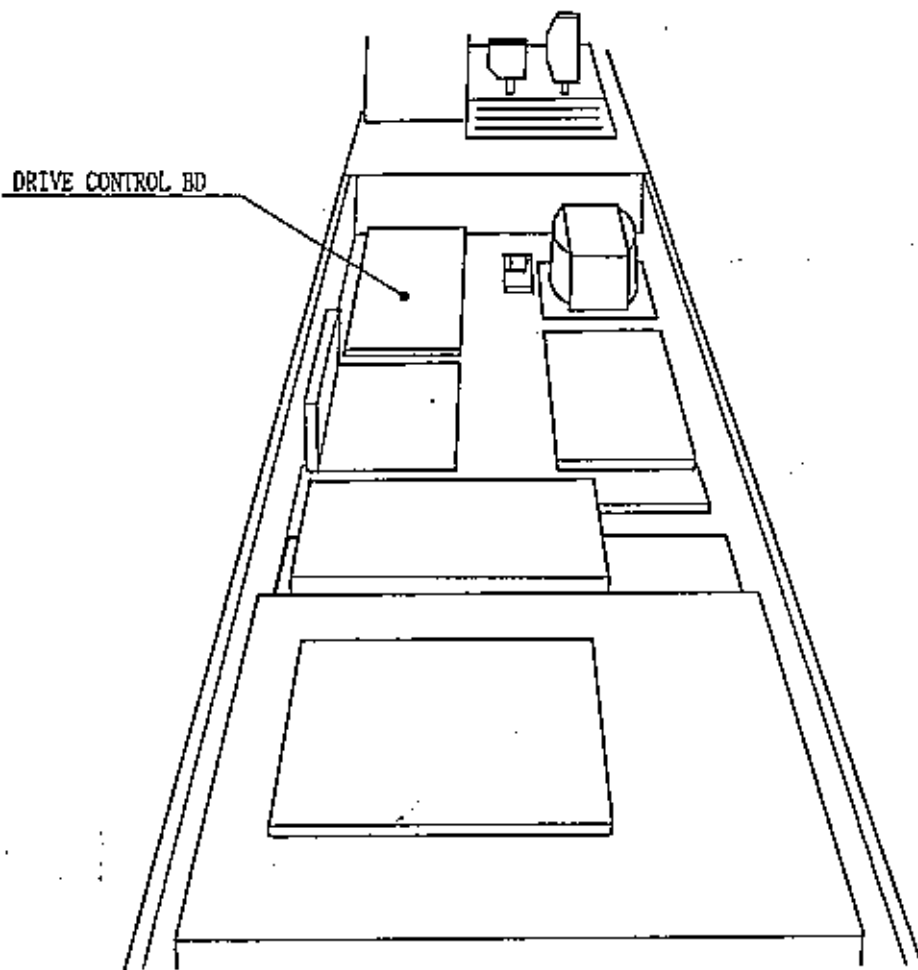

FIG. 18.3

If Error display is shown on the screen, incline the Seat without turning power off, and remove Base Lid F to check the 7-SEG display on the Drive Control Board. At this time, if the power is turned off, each of Er 23, 24 and 25 which could have occurred during operation may not be displayed.

18-4 DIP SW SETTING



- In order to prevent an electric shock and short circuit, be sure to turn power off before performing work by touching the interior parts of the product.
- Be careful so as not to damage wirings. Damaged wiring can cause an electric shock or short circuit accident.



- When changing DIP SW setting, be sure to turn power off. DIP SW setting is not effective unless power is turned off and then on again after the setting changes. Be sure to turn power off before making setting changes for the above-mentioned safety purpose, also.
- In the case where Fixed Setting is designated, be sure to perform DIP SW setting as specified in order to prevent malfunctioning. Among the DIP SW settings designated as Fixed Setting, some relate to factory check functioning and may not be appropriate for actual operation.

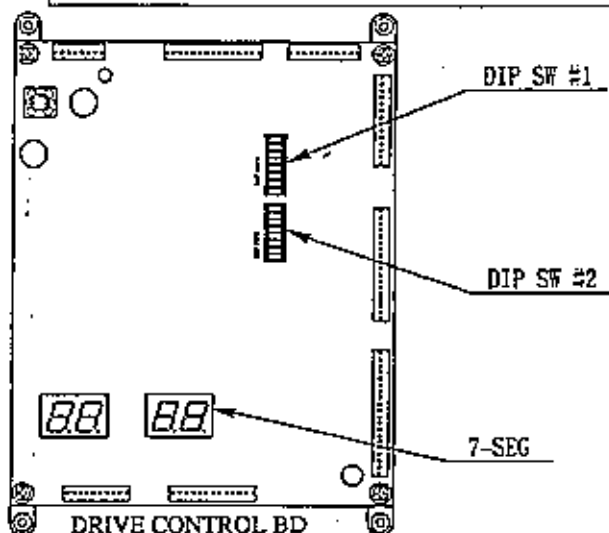

By changing the setting of DIP SW on the Drive Control BD, Steering Wheel strength can be varied. However, use this method only in case Motor Power setting in the Test mode will not do.

DIP SW #1

1	2	3	4	5	6	7	8	Contents of Setting
OFF	OFF	OFF				OFF	OFF	Fixed Setting (be sure to use this setting).
			OFF	OFF	OFF			Steering Wheel strength LEVEL1 Weak
			OFF	OFF	ON			Steering Wheel strength LEVEL2 ↑
			OFF	ON	OFF			Steering Wheel strength LEVEL3 ↑
			OFF	ON	ON			Steering Wheel strength LEVEL4 ↑
			ON	OFF	OFF			Steering Wheel strength LEVEL5 (Standard)
			ON	OFF	ON			Steering Wheel strength LEVEL6 ↓
			ON	ON	OFF			Steering Wheel strength LEVEL7 ↓
			ON	ON	ON			Steering Wheel strength LEVEL8 Strong

DIP SW #2

1	2	3	4	5	6	7	8	Contents of Setting
OFF	OFF	OFF	OFF	OFF	OFF	OFF	OFF	Fixed Setting (be sure to use this setting).

19. DESIGN RELATED PARTS

For the Warning Display stickers, refer to Section 1.

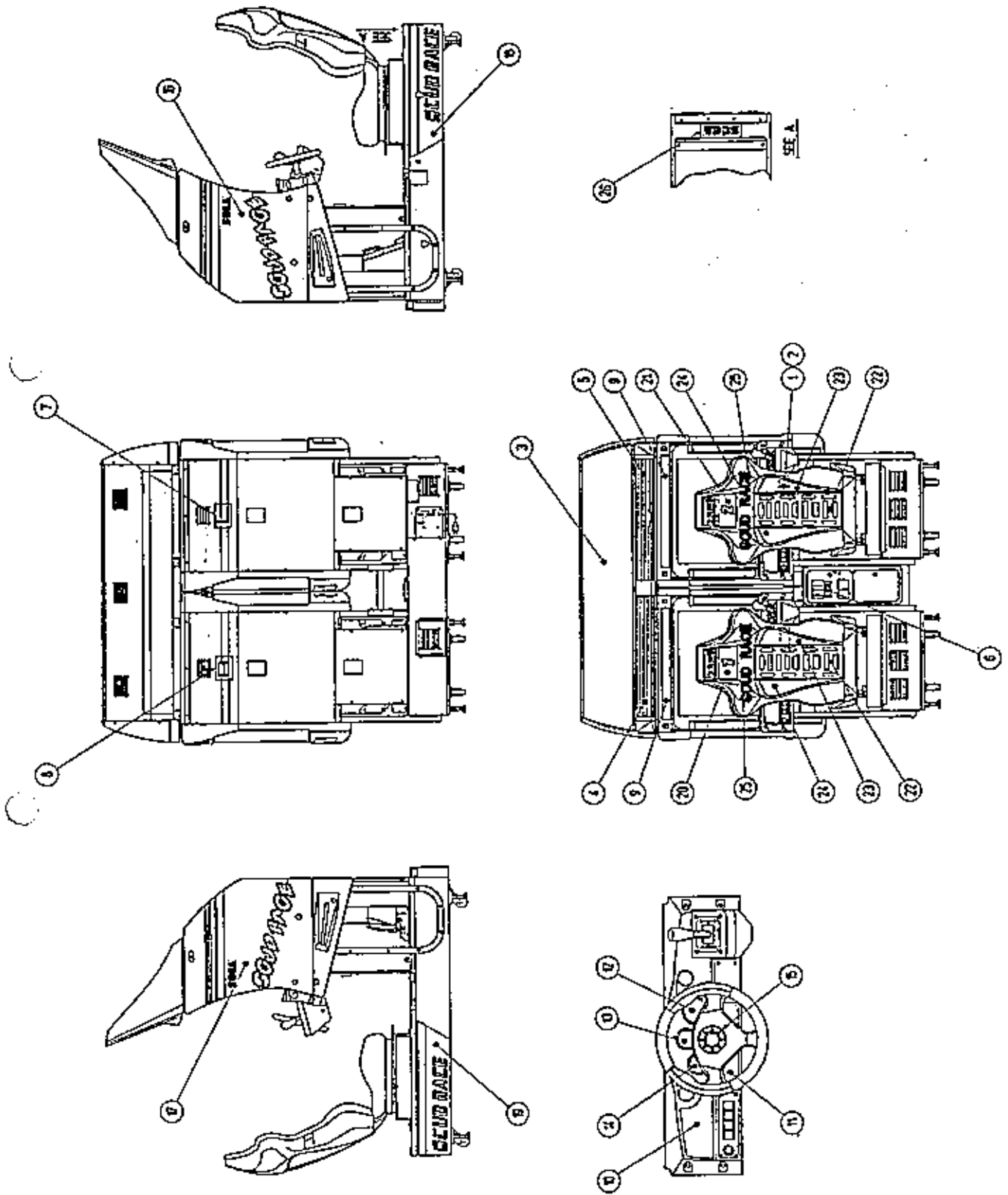

FIG. 19

TABLE 19

No.	PART No.	DESCRIPTION
1	DYN-0011	DENOMI PLATE W/O ORIGINAL
2	421-7308~	DENOMINATION SHEET 1GAME ~
3	423-0293	BILLBOARD PLATE UPPER
4	423-0291	BILLBOARD PLATE LOWER L
5	423-0292	BILLBOARD PLATE LOWER R
6	DYN-0303X	STICKER COIN ENTRY
7	421-8543	STICKER CABINET L
8	421-8544	STICKER CABINET R
9	422-0604-01	SUB INSTR SH SPG ENG
10	422-0608-01	PLAY INSTR SH SPG TWIN ENG
11	SPG-1201-C	METER PANEL
12	DYN-1214-C	DESIGN PL TACO MTR TWIN
13	DYN-1214-D	DESIGN PL OIL MTR TWIN
14	DYN-1214-E	DESIGN PL WATER MTR TWIN
15	SPG-2002	STEERING EMBLEM
16	SPG-1031-B	STICKER SIDE 1P L
17	SPG-1046-B	STICKER SIDE 2P R
18	SPG-1501-A	STICKER BASE L
19	SPG-1501-B	STICKER BASE R
20	SPG-2405-E	STICKER CAR NO. 1
21	SPG-1701-A	STICKER CAR NO. 2
22	SPG-2405-B	STICKER SEAT BACK A
23	SPG-2405-C	STICKER SEAT BACK B
24	SPG-2405-D	STICKER SEAT BACK C
25	SPG-2405-F	STICKER SEAT BACK D
26	SPG-1511-B	STICKER BASE LID R

20. COMMUNICATION PLAY

For this game, 4 machines can be connected to allow up to 8 players to play simultaneously.

20-1 INSTALLATION PRECAUTIONS

- 1) When linking a number of machines, be sure to supply sufficient power for the corresponding number of machines. The per unit standard voltage/ampereage is 100~120V/10A and 220~240V/5A.
- 2) Due to the length of the communications cable, the distance in between the machines will be approximately 0.2 meters or less.

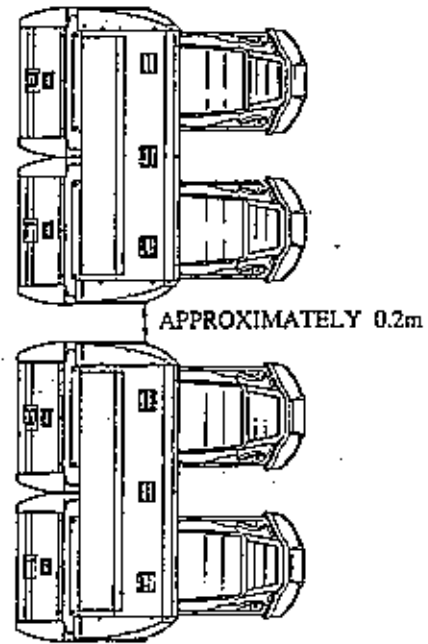

FIG. 20.1

20-2 CONNECTING THE COMMUNICATION CABLES

The PROTECT TUBE is used to link plural machine units and the communication cables are caused to pass through the PROTECT TUBE. Depending on the number of machine units to be linked, connect the communication cables (optic fiber cables) in the manner shown in Figures 20.2 f and 20.2 g.

- ① Take off the 4 screws and remove AC COVER B (Fig. 20.2 a).
- ② The HOLE LID is attached to the AC COVER HOLE into which the PROTECT TUBE is to be installed. By taking off 2 screws, remove the HOLE LID of the side where the PROTECT TUBE is to be installed.

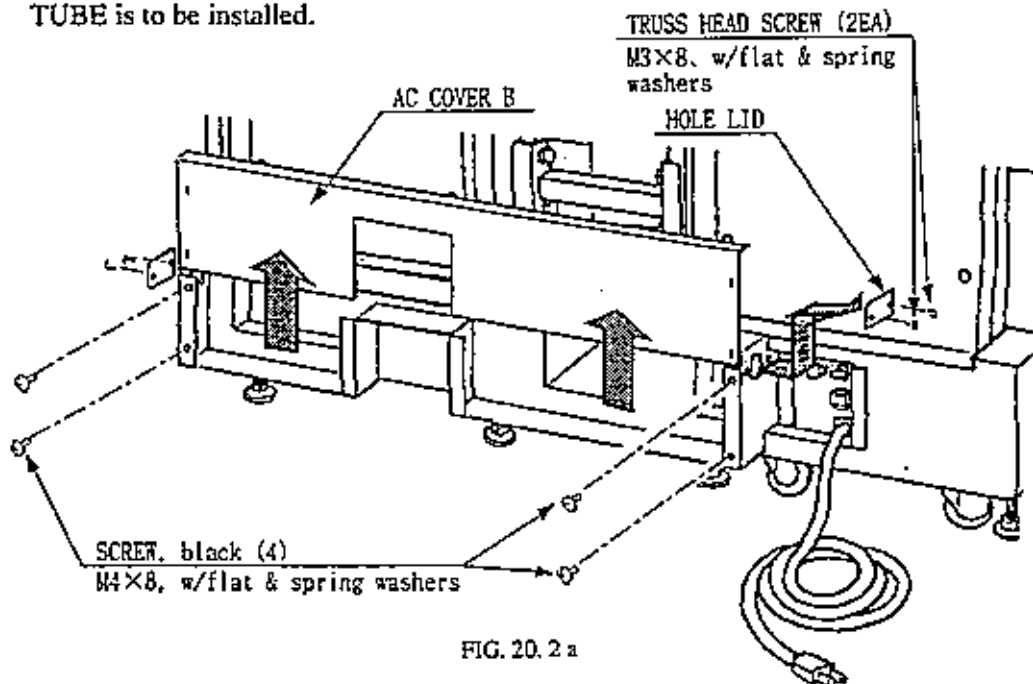

FIG. 20.2 a

- ③ Attach CONNECTOR 22 to the both ends of FLEX TUBE, and assemble the PROTECT TUBE. First, disassemble CONNECTOR 22 (Fig. 20. 2 b).
- ④ First pass the plastic nut through the flex tube. Otherwise, the following work can not be performed and therefore, be very careful of this point.
- ⑤ Install the holder and then the "insert" for both ends of the flex tube by turning them as in bolts and nuts (Fig. 20. 2 c).
- ⑥ Tighten the plastic nut to the connector. At this time, pass the optic fiber cable through the flex tube ahead of time so as to allow the following work to be performed easily (Fig. 20. 2 d).
- ⑦ Install the PROTECT TUBE into the AC COVER HOLE. Insert the connector into the AC COVER HOLE, put the seal washer through and fasten the metal nut (Fig. 20. 2 e).

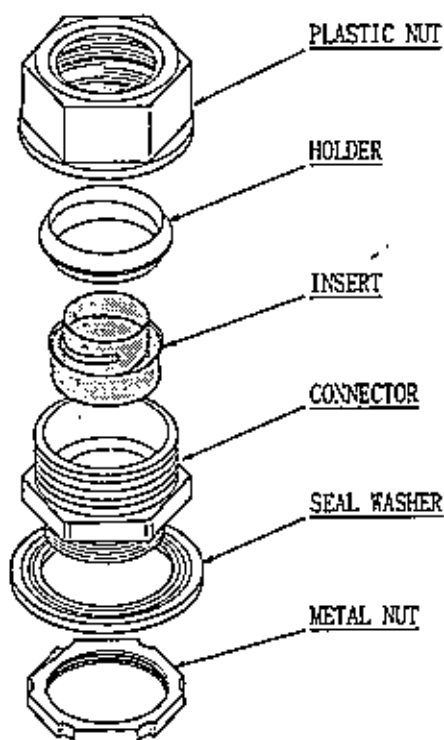

FIG. 20. 2 b

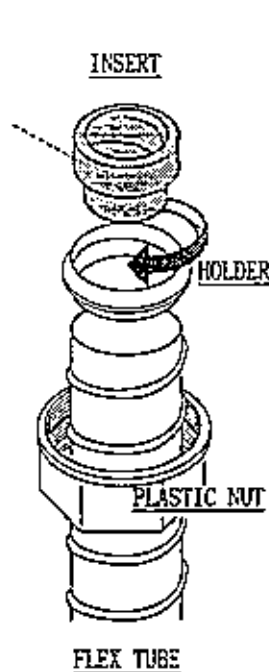

FIG. 20. 2 c

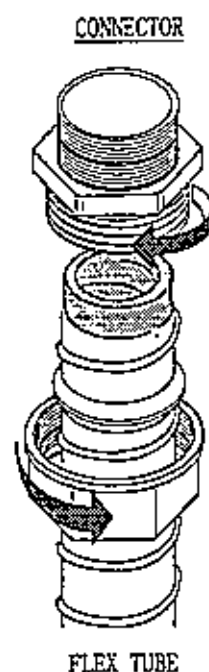

FIG. 20. 2 d

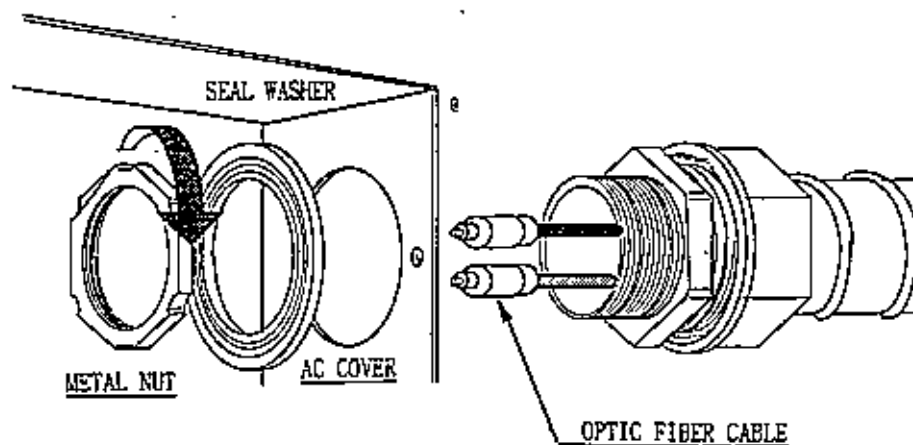

FIG. 20. 2 e

- ⑥ Connect the communication cable. Redo the connection which is currently made for TWIN (for 2P LINK) to change it for usage by 4P or more. Depending on the number of units to be connected, communication connections are different. Make connection correctly as shown below.



The optic fiber cable is used for the communication linkage. Excessive bending may damage the communication cable. Be very careful in this regard.

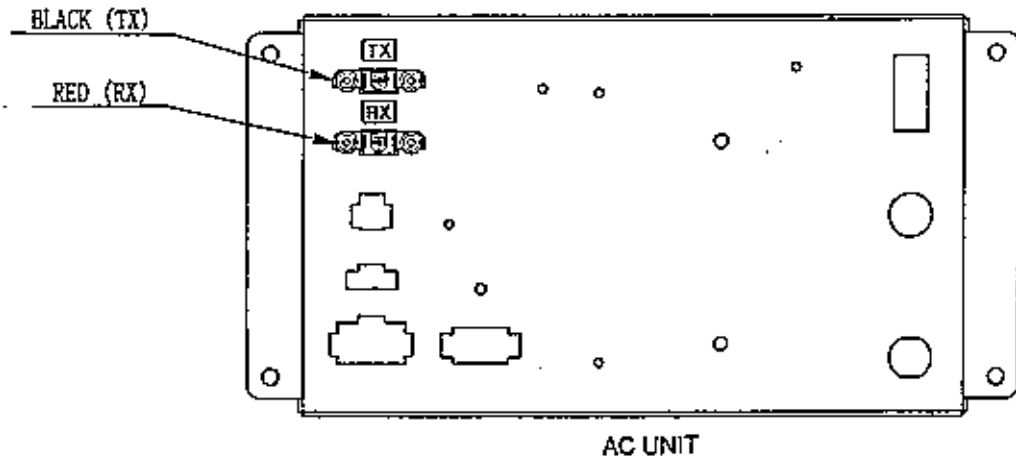
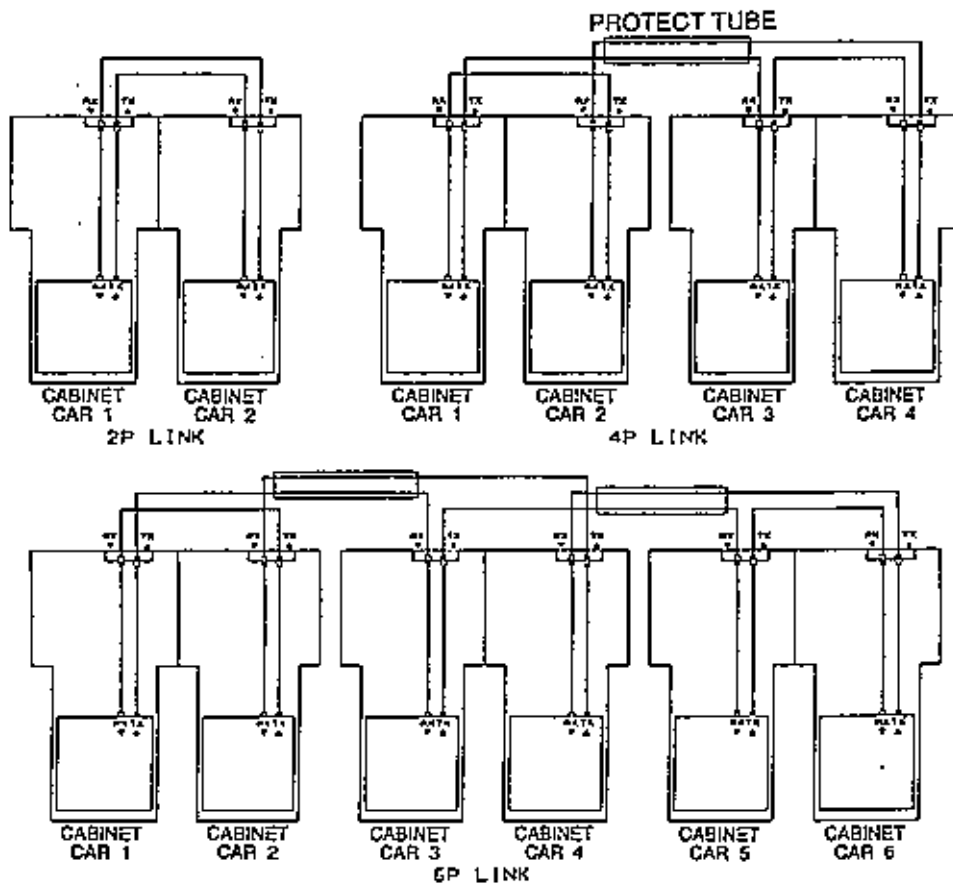

FIG. 20.2 f



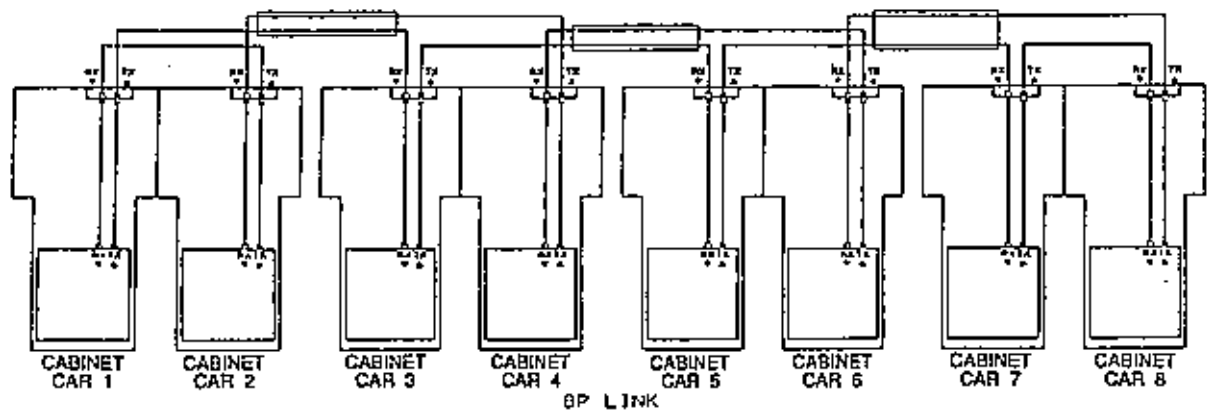

FIG. 20.2 g

- ⑨ Apply Seat No. Stickers in the manner corresponding to applicable seats. The seats are numbered sequentially in order of 1, 2, 3, ... starting from the left facing the front of the Monitor (refer to Section 19).

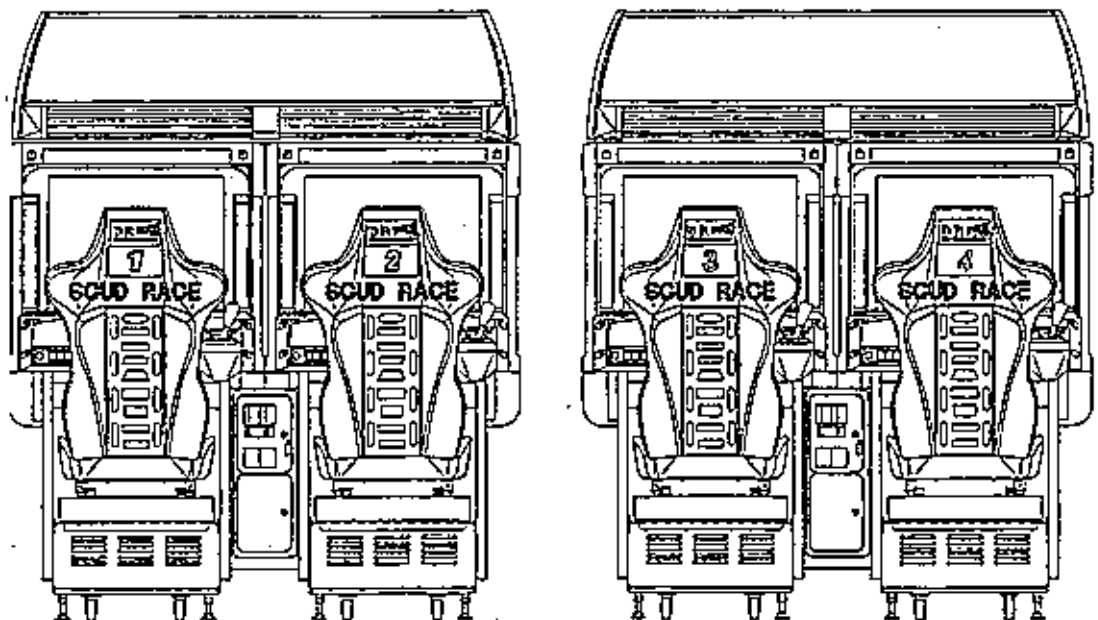

FIG. 20.2 h

20-3 SETTING FOR COMMUNICATION PLAY



During interactive play, if communication is interrupted due to some cause, the Network Check screen appears after finishing the game.

Cause all of the seats to enter the Test Mode and change the GAME ASSIGNMENTS of each seat for communication play. For the changing procedure, refer to the explanations of Section 9.

- ① Press the TEST button to enter the test mode and choose "GAME ASSIGNMENTS."
- ② Move the arrow mark (→) to "LINK ID" and press the TEST button to allow one of the cabinets to be set to "MASTER." Set all other cabinets to "SLAVE."
- ③ Bring the arrow mark (→) to "CAR NUMBER," press the TEST button and set plural number of the machines sequentially to No. 1, No. 2, No. 3 and so on as applicable starting from the extreme left facing the monitor's front side. If the same number is set for 2 or more cabinets, or if the sequential order is incorrect, the game display, etc. will be confused (different from the actual status). Therefore, be careful of this point.

In the case of communication play, only the settings of GAME DIFFICULTY and GAME MODE need to be performed by the "MASTER" seat. All other seats ("SLAVE") are subject to the setting change made by the "MASTER" seat. The above setting change made by any "SLAVE" seat is not effective and will not be reflected on the game. On the other hand, note that other settings such as ADVERTISE SOUND, MOTOR POWER, and COIN are performed by each seat.

GAME ASSIGNMENTS	
LINK ID	MASTER
CAR NUMBER	1
CABINET TYPE	TWIN
COUNTRY	XXXX
DIFFICULTY	NORMAL
ADVERTISE SOUND	ON
GAME MODE	NORMAL (SPRINT)
MOTOR POWER	80%
MULTI DISPLAY	OFF
→ EXIT	

SELECT WITH SERVICE BUTTON
AND PRESS TEST BUTTON

FIG. 20.3 GAME ASSIGNMENTS

20-4 CAUTIONS TO BE HEEDED WHEN USING THE TEST MODE:

Exiting from the test mode causes the unit to perform the network check automatically. During this time, all of the linked units will not allow the game to be played in normal status. Therefore, be sure not to enter the test mode if any one of the units is in play. On the other hand, if even one unit is in the test mode, make sure that other machines are not in play.

21. PARTS LIST

① TOP ASSY SPG TWIN

(D-1/3)

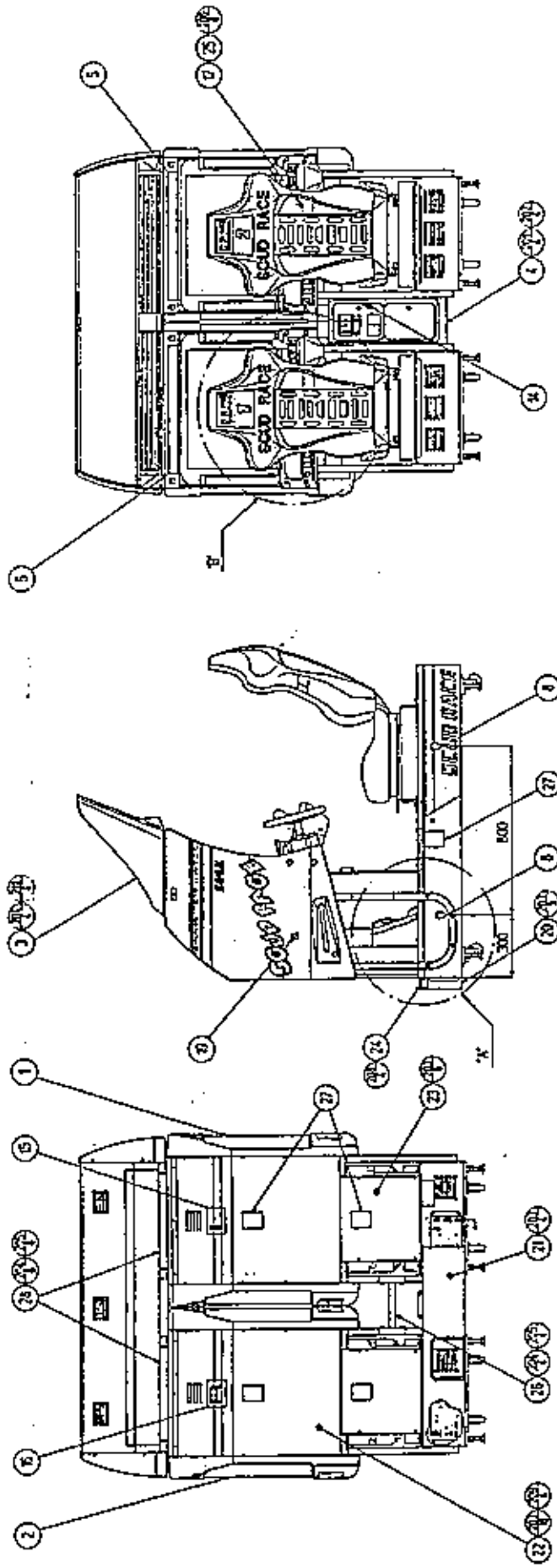

TORQUE: NB 105kgf-cm
 MA(N SCR) 10kgf-cm

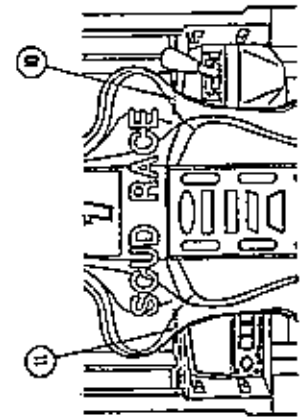

Details of PART B

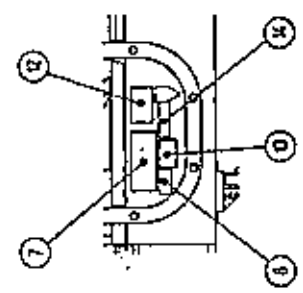

Details of PART A

① TOP ASSY SPG TWIN

(D-2/3)

ITEM NO.	PART NO.	DESCRIPTION	NOTE
1	SPG-10001	ASSY COCKPIT 1P	
2	SPG-11001	ASSY COCKPIT 2P	
3	SPG-0200	ASSY BILLBOARD	
4	SPG-0300	ASSY COINCHUTE TOWER	
5	422-0604-01	SUB INSTR SH SPG ENG	
6	421-6594-91	STICKER CERTIFICATE	
8	421-8885	STICKER CAUTION FORK	
12	421-7987	STICKER ELEC SPEC	OTHERS-
	421-8408	STICKER ELEC SPEC FOR TAIWAN	TAIWAN
14	421-7988-91	STICKER SERIAL NUMBER	
15	421-8543	STICKER CABINET L	
16	421-8544	STICKER CABINET R	
17	421-7308- ~	DENOMINATION SHEET 1GAME ~	
18	SGM-3863	POLYTHN COVER 950×1800×1700	
19	SPG-0005	BLIND CAP	
20	SPG-0006	AC COVER A	
21	DYN-0006X	AC COVER B	
22	INY-0004	BACK LID INY	
23	DYN-0008	BACK LID B	
24	DYN-0009	HOLE LID	
25	DYN-0011	DENOMI PLATE W/O ORIGINAL	
26	DYN-0013	JOINT PIPE	
27	440-WS0002XEG	STICKER W POWER OFF ENG	
28	SPG-0008	BILLBOARD HOLDER	
101	600-6275-0500	ASSY FIBER CABLE 5 0500CM	
102	280-5009-01	CORD CLAMP 21	
103	601-0460	PLASTIC TIE BELT 100 M/M	
201	030-000820-S	HEX BLT W/S M8×20	
202	068-852216	FLT WSHR 8.5-22×1.6	
203	000-P00408-WB	M SCR PH W/FS BLK M4×8	
204	030-000825-SB	HEX BLT W/S BLK M8×25	
205	060-F00800-0B	FLT WSHR BLK M8	
206	000-T00416-0C	M SCR TH CRW M4×16	
207	000-T00512-0B	M SCR TH BLK M5×12	
208	000-P00308-WB	M SCR PH W/FS BLK M3×8	
209	010-P00408-F	S-TITE SCR PH W/F M4×8	
210	008-T00408-0B	TMP PRF SCR TH BLK M4×8	
211	SLC-0006	FLAT WASHER 8.4-25×2	
301	600-6873-071	WIRE HARN EXT AC100V	
302	600-6873-054	WIRE HARN EXT S. VOLUME 1P A	
303	600-6873-055	WIRE HARN EXT S. VOLUME 2P A	
304	600-6873-056	WIRE HARN EXT TOWER 1P A	
305	600-6873-057	WIRE HARN EXT TOWER 2P A	
401	601-6604-70	CARTON BOX 70	
402	420-6289-01	OWNERS MANUAL SPG TWIN ENG	
403	SGM-2675	POLYETHYLENE BAG 240×370	
404	220-5576	KEY MASTER FOR 220-5575	
405	SGM-4111	KEY BAG (SGB-1035X)	

① TOP ASSY SPG TWIN

(D-3/3)

ITEM NO.	PART NO.	DESCRIPTION	NOTE
407	540-0009-01	WRENCH FOR TAMP SCR M8	
408	220-5373	VOL CONT B-5K	
	220-5484	VOL CONT B-5K OHM	
409	310-5050-220090	FLEX TUBE 22-0090CM	
410	310-5051-22	CONN 22	
411	090-0074	STATICIDE (300ML)	
412	509-5636	SW MICRO TYPE SS-5GL2T	
413	DYN-0020	JOINT PLATE	
415	421-9464	STICKER CAR NO 2-8	
416	514-5036-7000	FUSE 6.4×30 7000MA 125V	
/	421-6690-03	STICKER 220V	AC 220V AREA
/	421-6690-05	STICKER 240V	AC 240V AREA
/	421-6690-06	STICKER 110V	AC 110V AREA
/	600-6618	AC CABLE CONNECT TYPE FOR EXP	AC 220V~240V AREA

② ASSY BILLBOARD (SPG-0200)

(D-1/2)

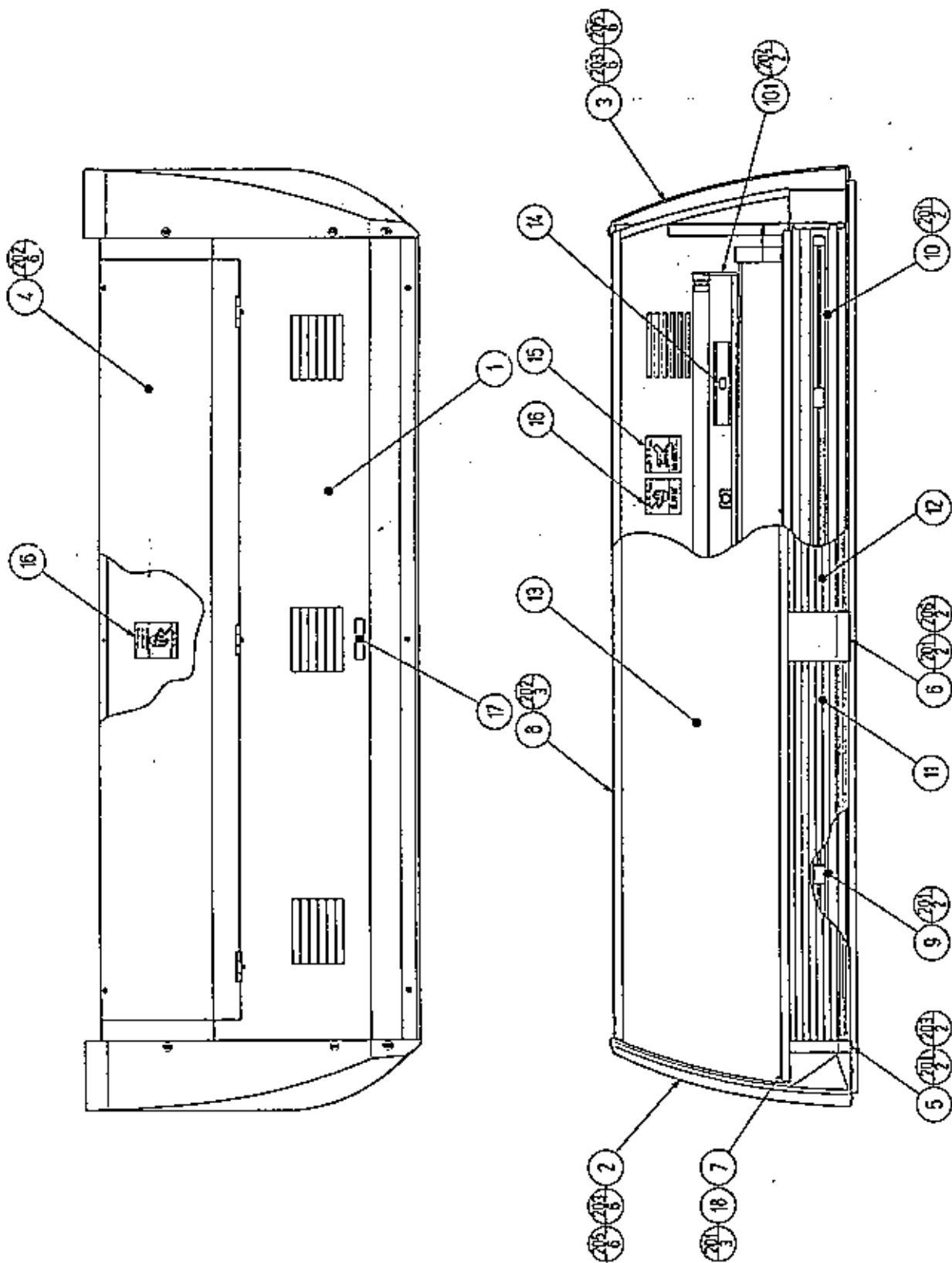

② ASSY BILLBOARD (SPG-0200)

(D-2/2)

ITEM NO.	PART NO.	DESCRIPTION	NOTE
1	SPG-0201	BILLBOARD BOX	
2	SPG-0202	SIDE COVER L	
3	SPG-0203	SIDE COVER R	
4	SPG-0204	BILLBOARD LID	
5	SPG-0205	HOLDER PLATE A	
6	SPG-0206	HOLDER PLATE B	
7	SPG-0207	LOWER SASH	
8	SPG-0208	UPPER SASH	
9	SPG-0210	ASSY REFLECTOR L	
10	SPG-0215	ASSY REFLECTOR R	
11	423-0291	BILLBOARD PLATE LOWER L	
12	423-0292	BILLBOARD PLATE LOWER R	
13	423-0293	BILLBOARD PLATE UPPER	
14	421-7501-10	STICKER FL 40W	
15	440-WS0012XEG	STICKER W HIGH TEMP ENG	
16	440-WS0002XEG	STICKER W POWER OFF ENG	
18	SPG-0209	CENTER CUSHION	
101	390-5538-40EX	ASSY FL40W EX W/CONN HIGH L	
	390-5636-40EX	ASSY FL40W EX W/CONN HIGH S	
	390-5637-40EX	ASSY FL40W EX W/CONN HIGH T	
102	280-5009-01	CORD CLAMP 21	
103	280-5275-SR10	CORD CLAMP SR10	
201	000-P00412-W	M SCR PH W/FS M4×12	
202	000-T00408-0C	M SCR TH CRM M4×8	
203	000-T00412-0C	M SCR TH CRM M4×12	
204	000-P00416-W	M SCR PH W/FS M4×16	
205	068-441616-0C	FLT WSHR CRM 4.4-16×1.6	
206	000-T00412-0B	M SCR TH BLK M4×12	
301	600-6873-067	WIRE HARN INVERTER	
302	600-6873-068	WIER HARN FL	

③ ASSY REFLECTOR L (SPG-0210)

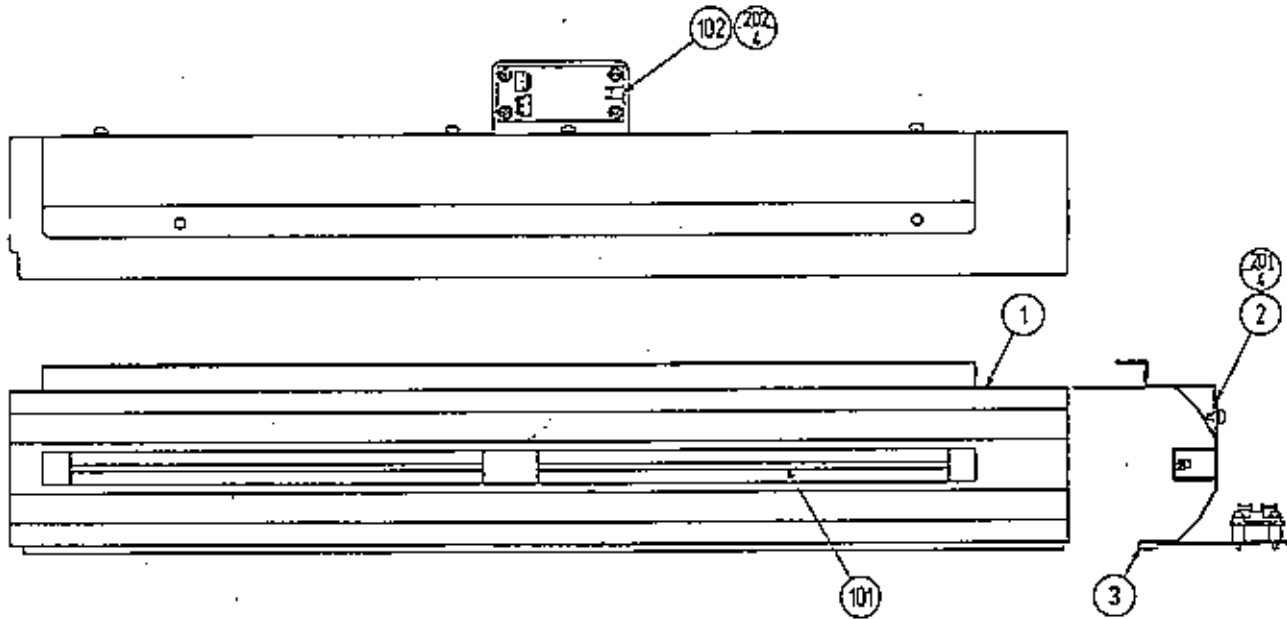

ITEM NO.	PART NO.	DESCRIPTION	NOTE
1	SPG-0211	REFLECTOR L	
2	SPG-0212	HOLDER	
3	SPG-0213	CUSHION	
101	390-5697	CATHODE TUBE GREEN W/CONN	
102	838-13038	CATHODE TUBE INVERTER 12V	
103	280-5275-SR10	CORD CLAMP SR10	
104	601-0460	PLASTIC TIE BELT 100MM	
201	000-P00408-W	M SCR PH W/FS M4×8	
202	000-P00320-W	M SCR PH W/FS M3×20	

④ ASSY REFLECTOR R (SPG-0215)

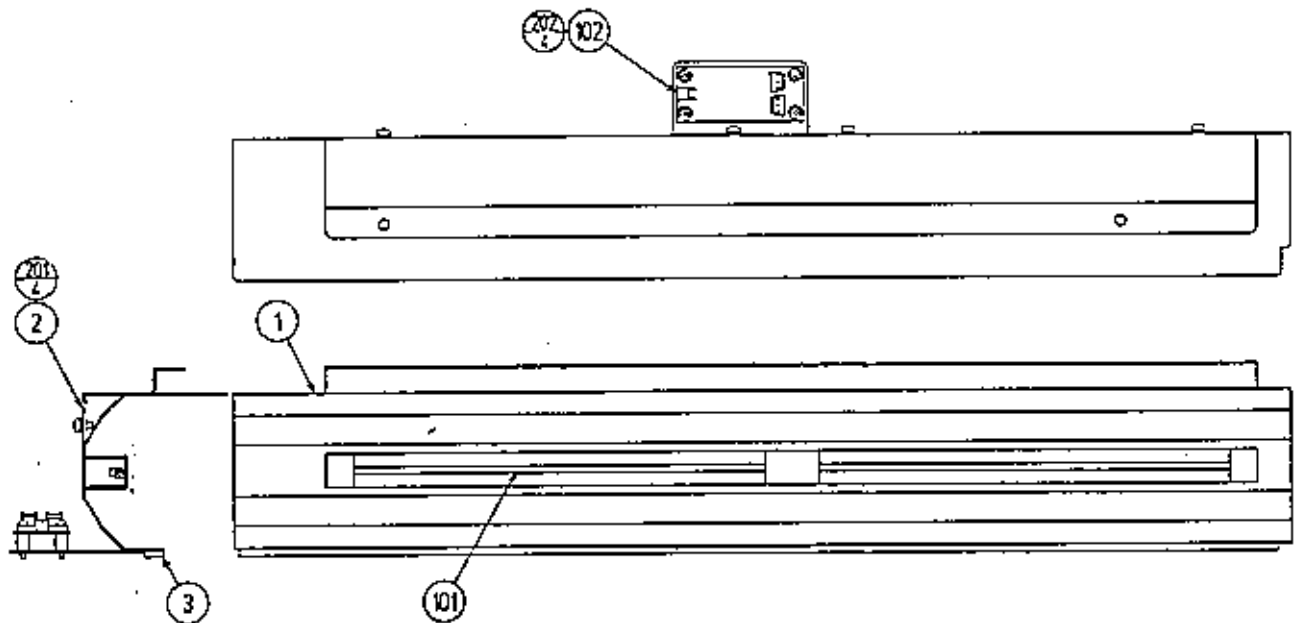

ITEM NO.	PART NO.	DESCRIPTION	NOTE
1	SPG-0216	REFLECTOR R	
2	SPG-0212	HOLDER	
3	SPG-0213	CUSHION	
101	390-5697	CATHODE TUBE GREEN W/CONN	
102	838-13038	CATHODE TUBE INVERTER 12V	
103	280-5275-SR10	CORD CLAMP SR10	
104	601-0460	PLASTIC TIE BELT 100MM	
201	000-P00408-W	M SCR PH W/FS M4×8	
202	000-P00320-W	M SCR PH W/FS M3×20	

⑤ ASSY COINCHUTE TOWER (SPG-0300)

(D-1/2)

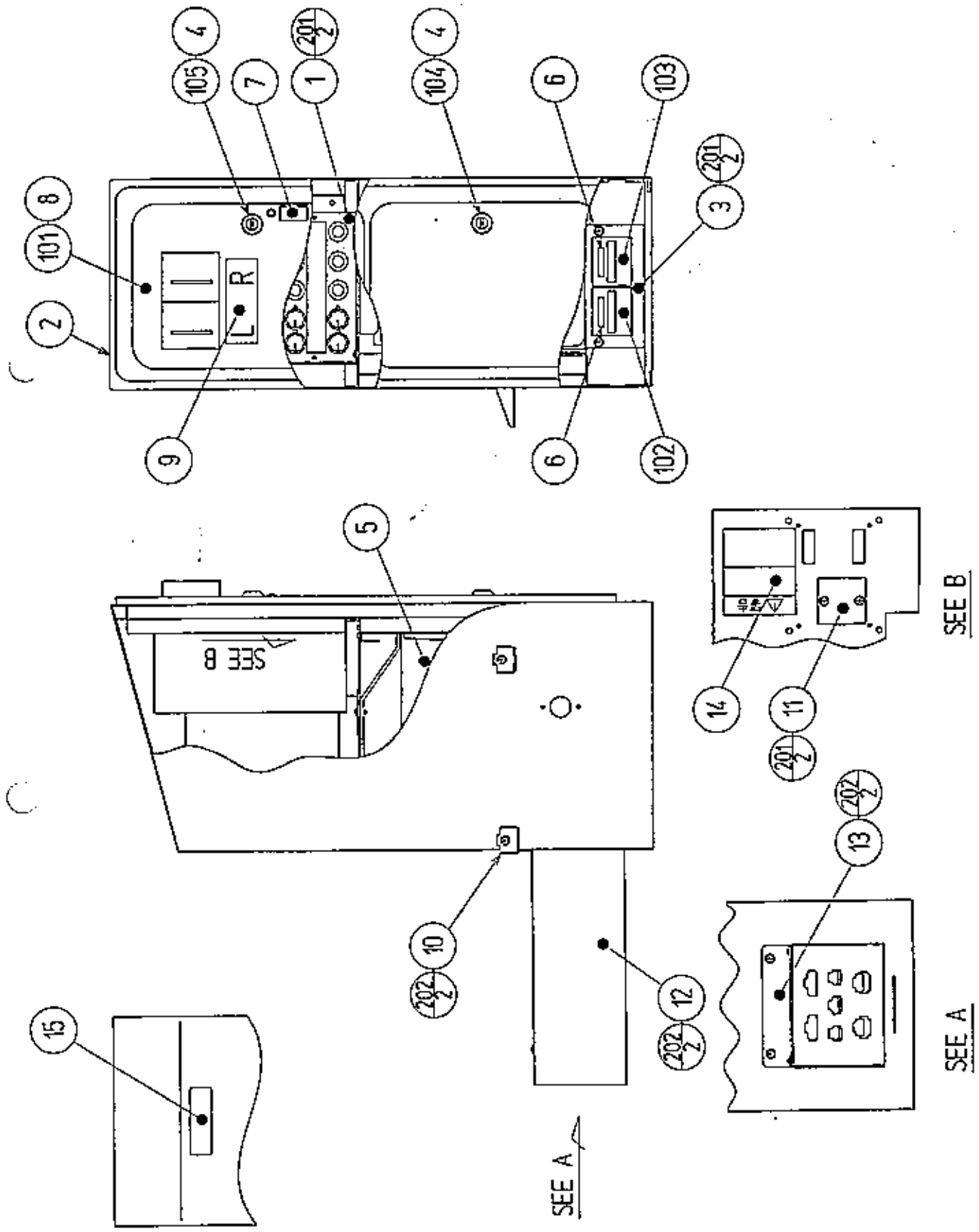

⑤ ASSY COINCHUTE TOWER (SPG-0300)

(D-2/2)

ITEM NO.	PART NO.	DESCRIPTION	NOTE
1	SPG-0350	SW UNIT	
2	SPG-0301	COIN CHUTE TOWER	
3	DYN-0302Y	COIN METER BRKT	
4	DP-1167	TNG LKG	
5	253-5366	CASH BOX	
6	421-6591-01	STICKER COIN METER	
8	421-7501-02	STICKER 6.3V 0.15A	
9	DYN-0303X	STICKER COIN ENTRY	
10	DYN-0305	TOWER BRKT	
11	105-5202	HOLE COVER	
12	SPG-0302	WIER BOX	
13	SPG-0303	WIER BOX LID	
14	440-WS0002XEG	STICKER W POWER OFF ENG	
101	220-5237-92- ~	ASSY C. C 2DR ~	
102	220-5412	MAG CNTR W/CONN	
103	220-5412-01	MAG CNTR W/CONN BLACK	
104	220-5574	CAM LOCK W/KEYS	
105	220-5575	CAM LOCK MASTER W/O KEY	
106	280-5009-01	CORD CLAMP 21	
107	280-5275-SR10	CORD CLAMP SR10	
108	601-0460	PLASTIC TIE BELT 100 M/M	
109	310-5029-F20	SUMI TUBE FF 20MM	
110	601-6231-C045	EDGING NEY TYPE	
201	000-P00412-W	M SCR PH W/FS M4×12	
202	000-T00408-0B	M SCR TH BLK M4×8	
203	010-P00408-F	S-TITE SCR PH W/F M4×8	
301	600-6373-50	WIRE HARN COIN LEFT	
302	600-6373-51	WIRE HARN COIN RIGHT	
303	600-6373-71	WIRE HARN EARTH COINCHUTE	
304	600-6873-058	WIRE HARN EXT S. VOLUME 1P B	
305	600-6873-059	WIRE HARN EXT S. VOLUME 2P B	
306	600-6873-060	WIRE HARN EXT TOWER 1P B	
307	600-6873-061	WIRE HARN EXT TOWER 2P B	
308	600-6873-062	WIRE HARN EXT COIN 1P	
309	600-6873-063	WIRE HARN EXT COIN 2P	
310	600-6873-069	WIRE HARN EXT S. VOLUME 1P C	
311	600-6873-070	WIRE HARN EXT S. VOLUME 2P C	
312	600-6373-48	WIRE HARN COIN METER LEFT	
313	600-6373-49	WIRE HARN COIN METER RIGHT	
314	600-6373-52	WIRE HARN EXT SW UNIT LEFT	
315	600-6373-66	WIRE HARN EXT SW UNIT RIGHT	

⑥ SW UNIT (SPG-0350)

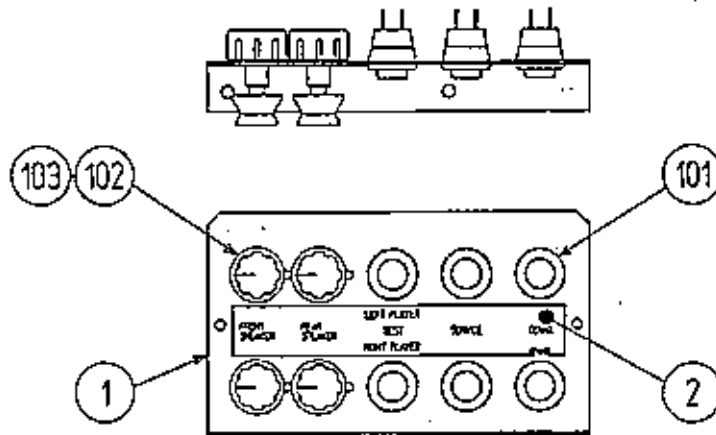

Wire Adjustment

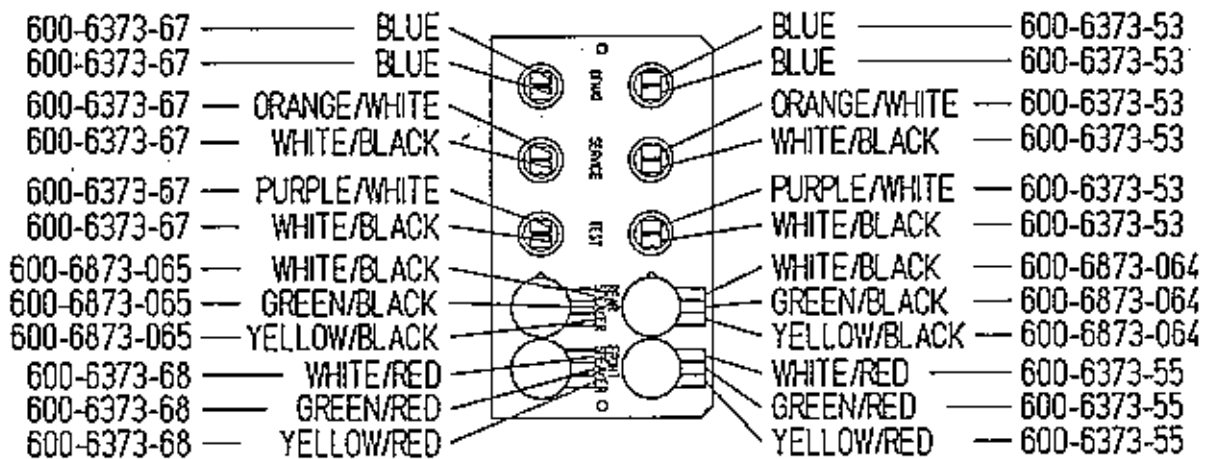

ITEM NO.	PART NO.	DESCRIPTION	NOTE
1	SPG-0351	SW BRKT	
2	421-9482	STICKER SW UNIT 2P	
101	509-5028	SW PB 1M	
102	220-5179	VOL CONT B-5K OHM	
103	601-0042	KNOB 22 MM	
104	601-0460	PLASTIC TIE BELT 100 M/M	
105	310-5029-F20	SUMI TUBE FF 20MM	
301	600-6373-53	WIER HARN TEST & SERVICE LEFT	
302	600-6373-55	WIRE HARN VOL. LEFT	
303	600-6373-67	WIRE HARN TBST & SERVICE RIGHT	
304	600-6373-68	WIRE HARN VOL. RIGHT	
305	600-6873-064	WIRE HARN S. VOLUME 1P	
306	600-6873-065	WIRE HARN S. VOLUME 2P	

⑦ AC UNIT MAIN (SPG-0400)

(0-1/2)

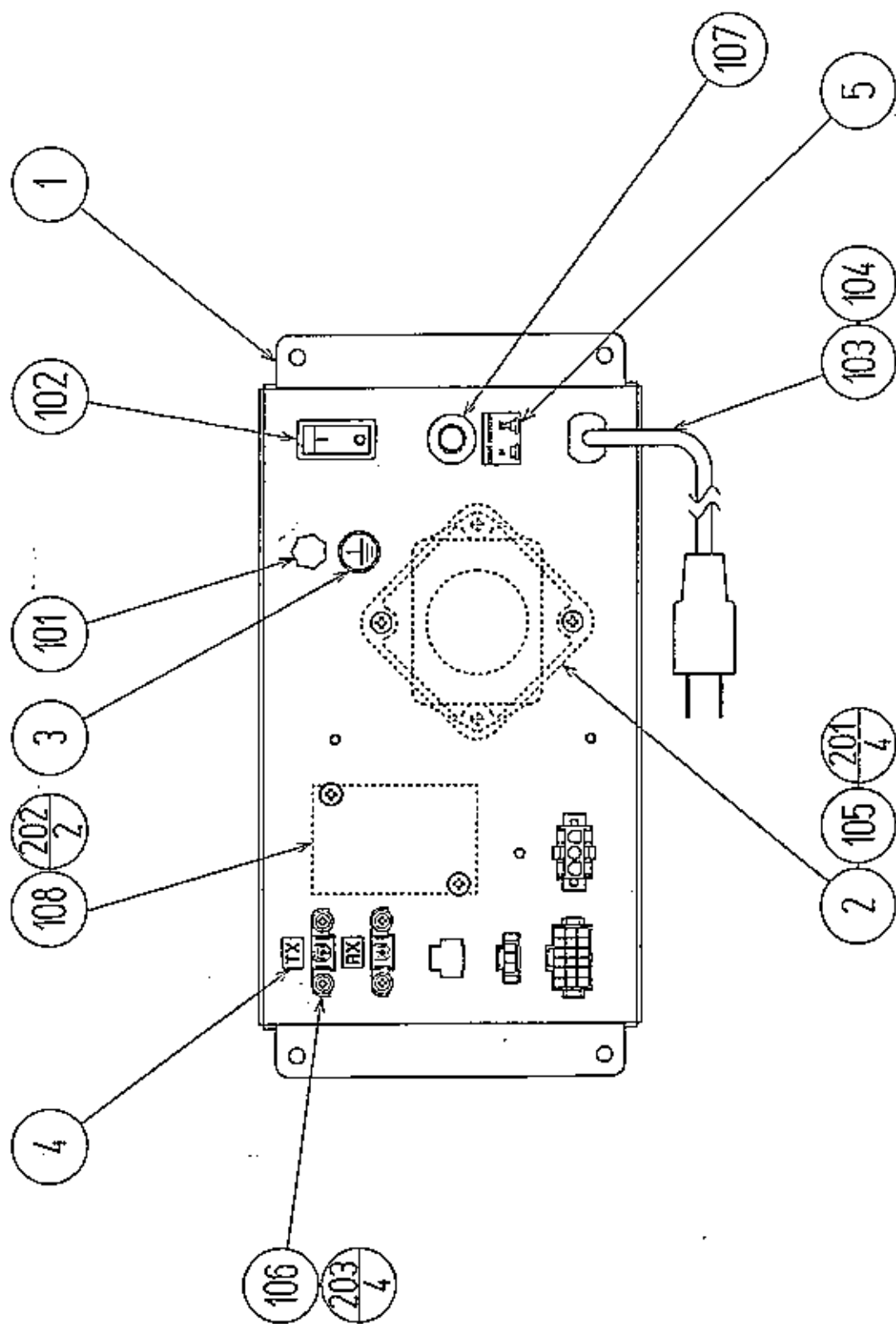

⑦ AC UNIT MAIN (SPG-0400)

(0-2/2)

ITEM NO.	PART NO.	DESCRIPTION	NOTE
1	SPG-0401	AC BRKT	
2	DYN-0402	NOISE FILTER BASE	
3	421-8202	STICKER EARTH MARK	
4	421-7515	STICKER FIBER CABLE TX/RX	
5	421-7468-01	STICKER C. P W/PIC	
101	280-0417	TERMINAL BINDING POST BLACK	
102	509-5453-V-B	SW ROCKER J8 V-B	
103	280-5134-6N34	BUSHING STRAIN RELIEF 6N34	
104	600-5843-25	CA & PLUG ASSY 15A W/F- L=2.5M	
105	270-5115	NOISE FILTER 15A GT-215J	
106	211-5479-01	CONN OPT JOINT	
107	512-5046-15000	C. P 15000MA CE UL	
108	450-5126	MAGNET CONTACT S-NIOCX	
109	209-0032	CONN CLOSED END	
110	310-5029-F20	SUMI TUBE FF 20MM	
111	280-5009-01	CORD CLAMP 21	
112	601-0460	PLASTIC TIE BELT 100 M/M	
201	012-P00408	TAP SCR #2 PH 4x8	
202	000-P00416-WB	M SCR PH W/FS BLK M4x16	
203	000-P00312-W	M SCR PH W/FS M3x12	
301	600-6873-026	WIRE HARN AC UNIT MAIN A	
302	600-6873-027	WIRE HARN AC UNIT MAIN B	
304	600-6873-029	WIRE HARN AC UNIT MAIN D	
305	600-6873-030	WIRE HARN AC UNIT MAIN E	
306	600-6873-031	WIRE HARN AC UNIT MAIN F	
307	600-6873-052-91	WIRE HARN EXT AC UNIT PANEL	

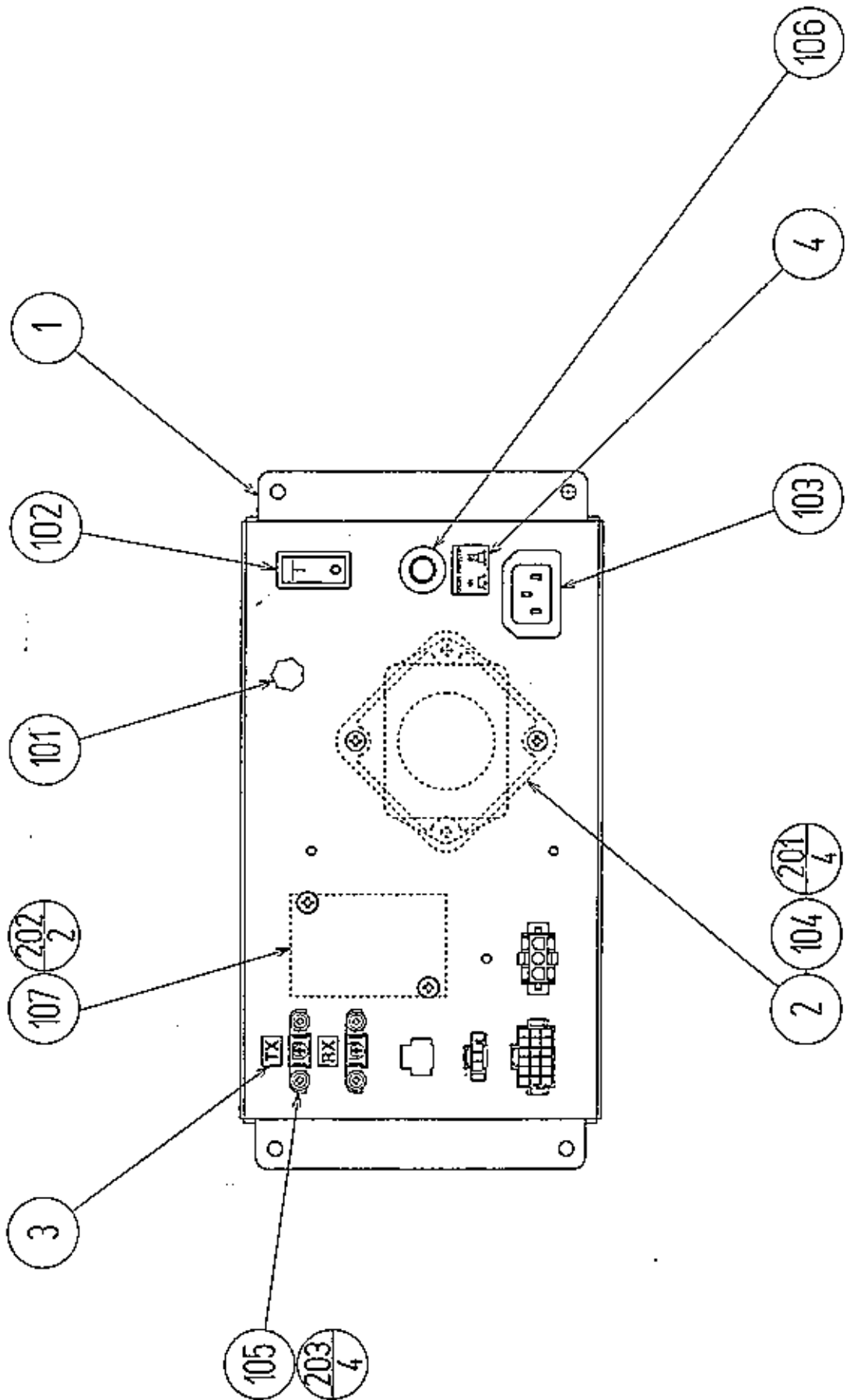

⑦ AC UNIT MAIN EXP (SPG-0400-01)

(D-2/2)

ITEM NO.	PART NO.	DESCRIPTION	NOTE
1	SPG-0401-01	AC BRKT EXP	
2	DYN-0402	NOISE FILTER BASE	
3	421-7515	STICKER FIBER CABLE TX/RX	
4	421-7468-01	STICKER C.P W/PIC	
101	280-0417	TERMINAL BINDING POST BLACK	
102	509-5453-V-B	SW ROCKER JS V-B	
103	214-0202	AC INLET PANEL TYPE	
104	270-5115	NOISE FILTER 15A GT-215J	
105	211-5479-01	CONN OPT JOINT(TOCA150S)	
106	512-5046-8000	C.P 8000MA CE UL	
107	450-5134	MAGNET CONTACT S-NIOCX AC230V	
108	310-5029-K20	SUMITUBE F K20MM	
109	280-5009-01	CORD CLAMP 21	
110	601-0460	PLASTIC TIE BELT 100 M/M	
201	012-P00408	TAP SCR #2 PH 4x8	
202	000-P00416-WB	M SCR PH W/FS BLK M4x16	
203	000-P00312-W	M SCR PH W/FS M3x12	
301	600-6873-027	WIRE HARN AC UNIT MAIN B	
302	600-6873-029	WIRE HARN AC UNIT MAIN D	
303	600-6873-030	WIRE HARN AC UNIT MAIN E	
304	600-6873-031	WIRE HARN AC UNIT MAIN F	
305	600-6873-052	WIRE HARN EXT AC UNIT PANEL	
306	600-6873-072	WIRE HARN AC UNIT MAIN EXP	

⑦ AC UNIT MAIN KOREA (SPG-0400-02)

(D-1/2)

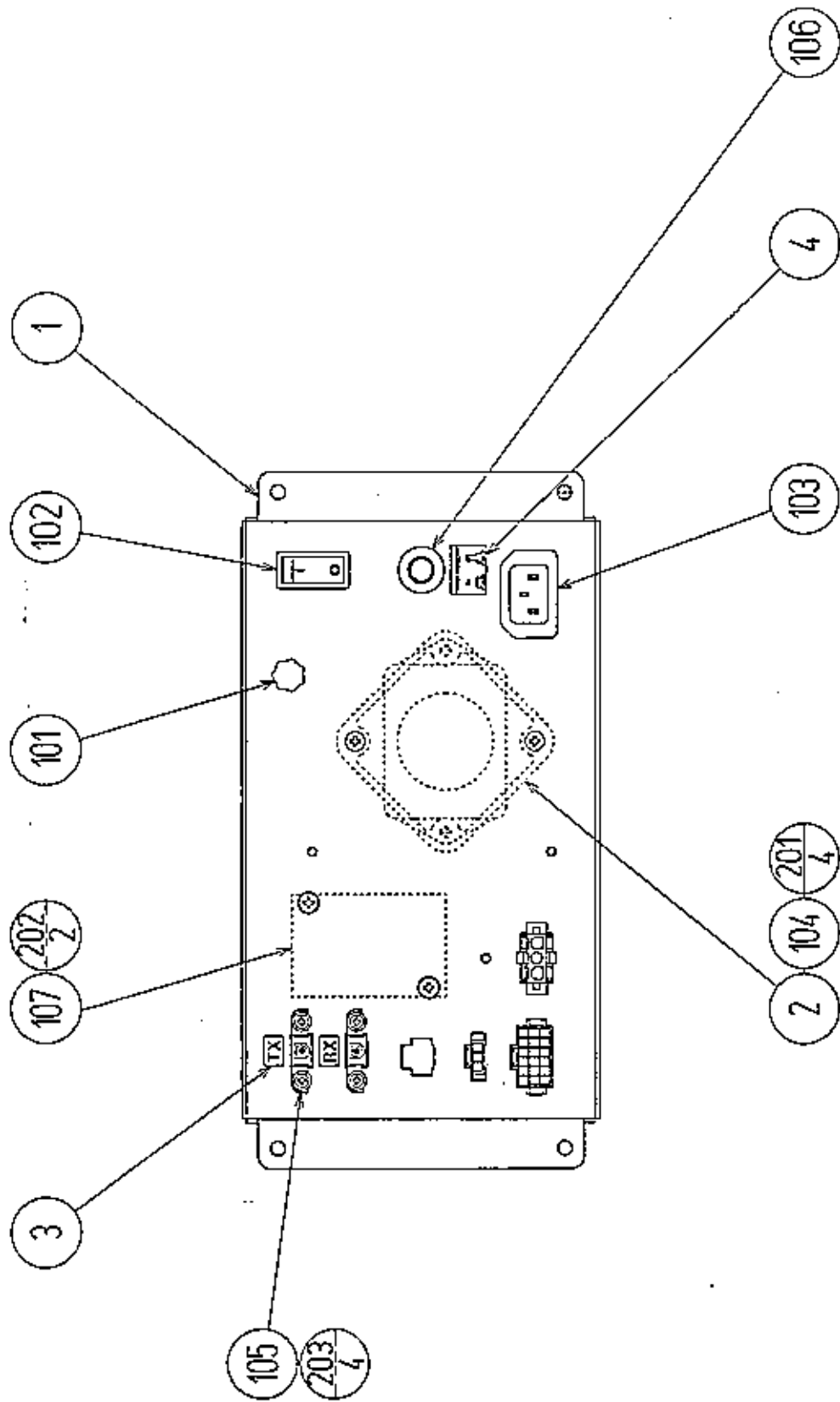

⑦ AC UNIT MAIN KOREA (SPG-0400-02)

(D-2/2)

ITEM NO.	PART NO.	DESCRIPTION	NOTE
1	SPG-0401-01	AC BRKT EXP	
2	DYN-0402	NOISE FILTER BASE	
3	421-7515	STICKER FIBER CABLE TX/RX	
4	421-7468-01	STICKER C. P W/PIC	
101	280-0417	TERMINAL BINDING POST BLACK	
102	509-5453-V-B	SW ROCKER JS V-B	
103	214-0202	AC INLET PANEL TYPE	
104	270-5115	NOISE FILTER 15A GT-215J	
105	211-5479-01	CONN OPT JOINT(TOCA150S)	
106	512-5046-8000	C. P 8000MA CE UL	
107	450-5133	MAGNET CONTACT S-NIOCX AC200V	
108	310-5029-K20	SUMITUBE F K20MM	
109	280-5009-01	CORD CLAMP 21	
110	601-0460	PLASTIC TIE BELT 100 M/M	
201	012-P00408	TAP SCR #2 PH 4×8	
202	000-P00416-WB	M SCR PH W/FS BLK M4×16	
203	000-P00312-W	M SCR PH W/FS M3×12	
301	600-6873-027	WIRE HARN AC UNIT MAIN B	
302	600-6873-029	WIRE HARN AC UNIT MAIN D	
303	600-6873-030	WIRE HARN AC UNIT MAIN E	
304	600-6873-031	WIRE HARN AC UNIT MAIN F	
305	600-6873-052	WIRE HARN EXT AC UNIT PANEL	
306	600-6873-072	WIRE HARN AC UNIT MAIN EXP	

⑦ AC UNIT MAIN AUS (SPG-0400-03)

(0-1/2)

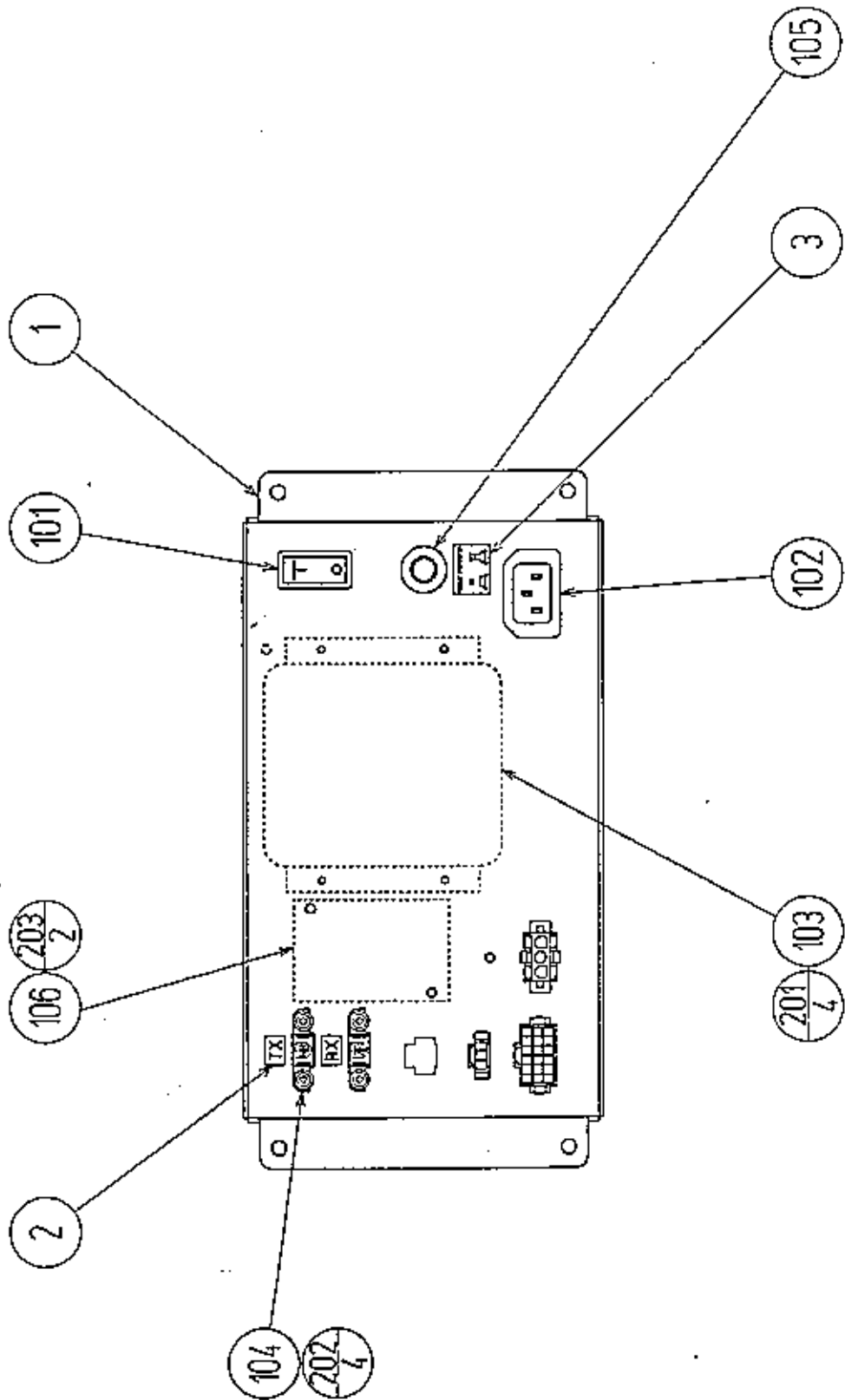

⑦ AC UNIT MAIN AUS (SPG-0400-03)

(D-2/2)

ITEM NO.	PART NO.	DESCRIPTION	NOTE
1	SPG-0401-02	AC BRKT AUS	
2	421-7515	STICKER FIBER CABLE TX/RX	
3	421-7468-01	STICKER C. P W/PIC	
101	509-5453-V-B	SW ROCKER J8 V-B	
102	214-0202	AC INLET PANEL TYPE	
103	270-5120	N. F 10A CB(BELLING LEE SF4220)	
104	211-5479-01	CONN OPT JOINT(TOCA150S)	
105	512-5046-8000	C. P 8000MA CB UL	
106	450-5134	MAGNET CONTACT S-NIOCK AC230V	
107	310-5029-K20	SUMITUBE F K20MM	
108	280-5009-01	CORD CLAMP 21	
109	601-0460	PLASTIC TIE BELT 100 M/M	
201	000-P00308-WB	M SCR PH W/FS BLK M3×8	
202	000-P00312-WB	M SCR PH W/FS BLK M3×12	
203	000-P00416-WB	M SCR PH W/FS BLK M4×16	
204	050-F00400	FLG NUT M4	
301	600-6873-052-91	WIRE HARN EXT AC UNIT PANEL	
302	600-6873-074	WIRE HARN AC UNIT MAIN EXP2 A	
303	600-6873-075	WIRE HARN AC UNIT MAIN EXP2 B	
304	600-6873-076	WIRE HARN AC UNIT MAIN EXP2 C	
305	600-6873-077	WIRE HARN AC UNIT MAIN EXP2 D	
306	600-6873-078	WIRE HARN AC UNIT MAIN EXP2 E	
307	600-6873-079	WIRE HARN AC UNIT MAIN EXP2 F	

⑧ AC UNIT SUB (SPG-0700)

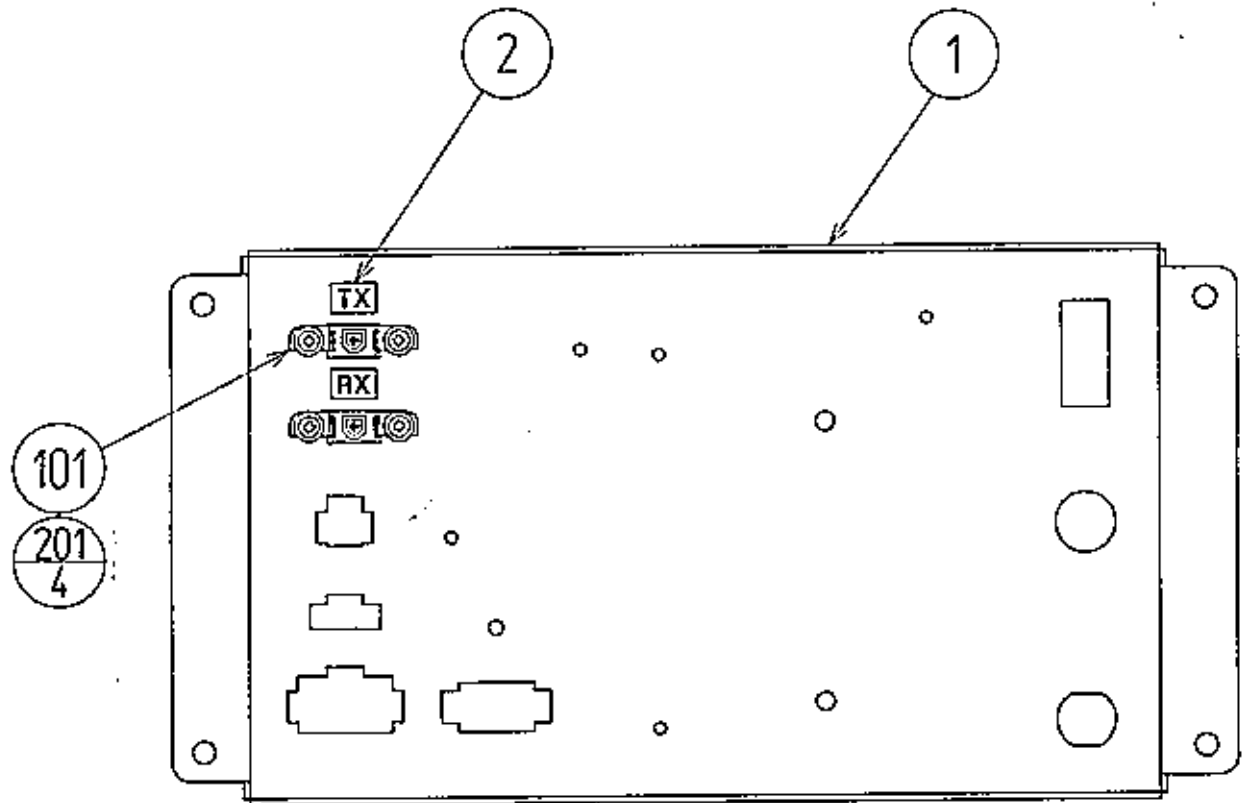

ITEM NO.	PART NO.	DESCRIPTION	NOTE
1	SPG-0401	AC BRKT	
2	421-7515	STICKER FIBER CABLE TX/RX	
101	211-5479-01	CONN OPT JOINT	
201	000-P00312-W	M SCR PH W/FS M3×12	
301	600-6873-052-91	WIRE HARN EXT AC UNIT PANEL	
302	600-6873-066	WIRE HARN AC UNIT SUB	

⑨ ASSY COCKPIT 1P (SPG-10001)

(D-1/2)

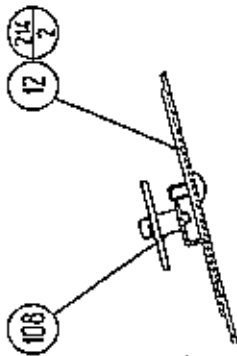

Details of PART B

For ADJUSTMENT

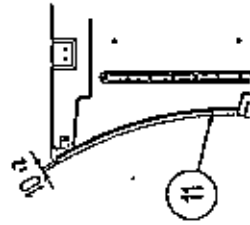
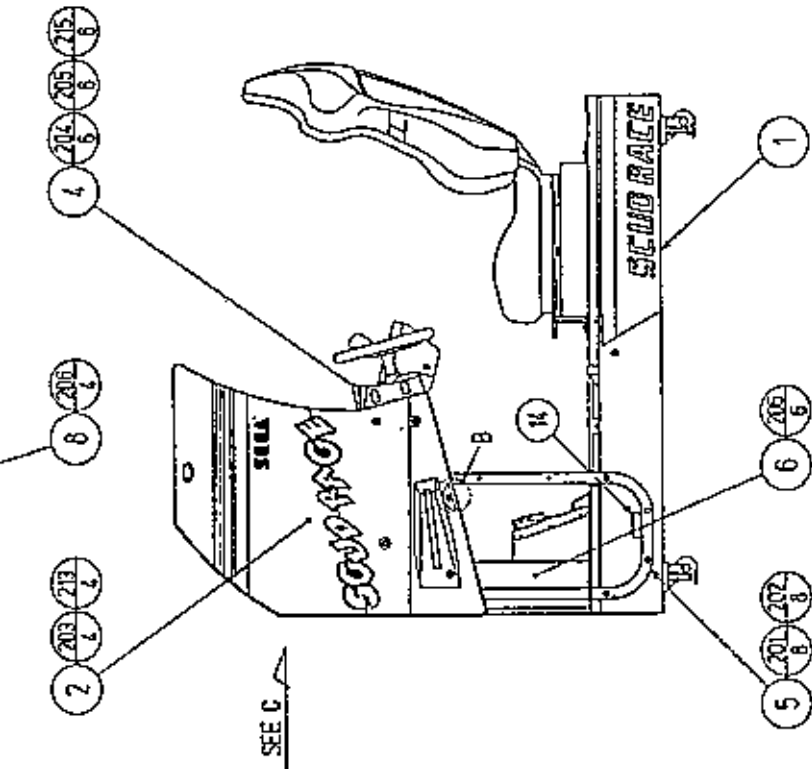
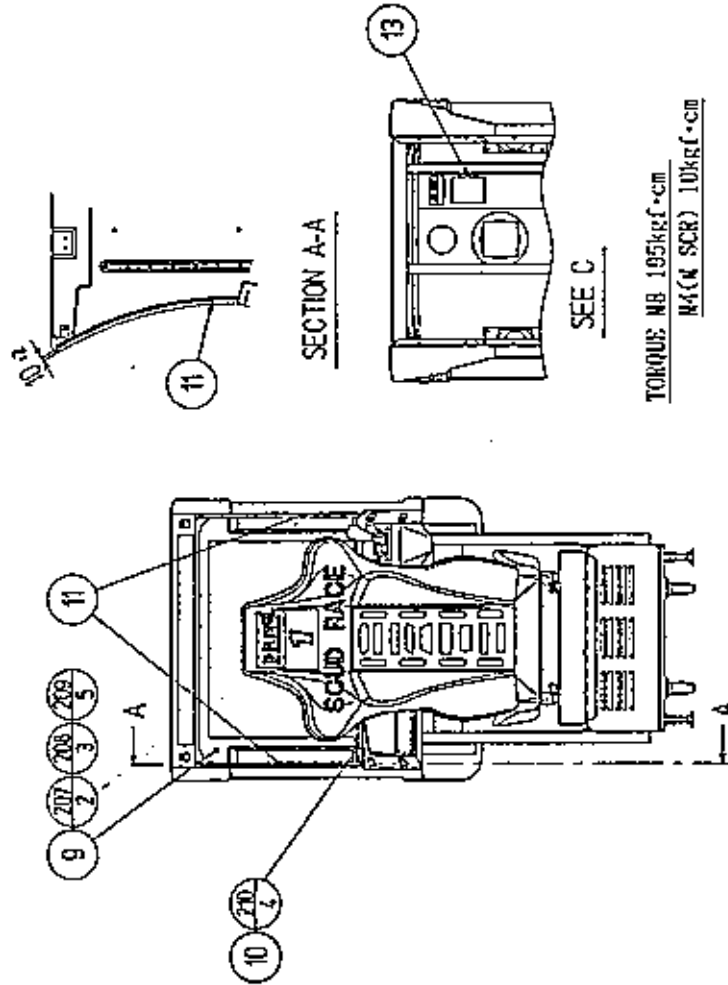
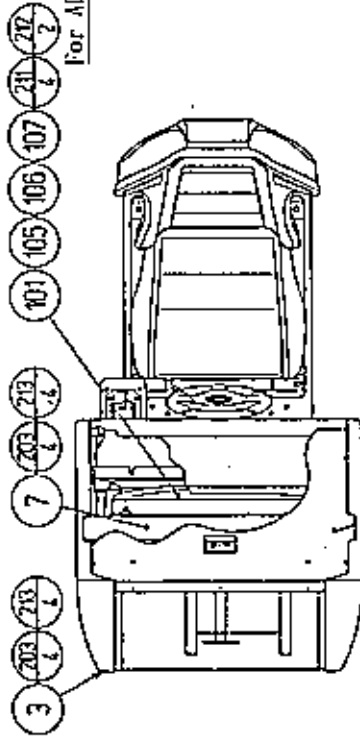

SECTION A-A

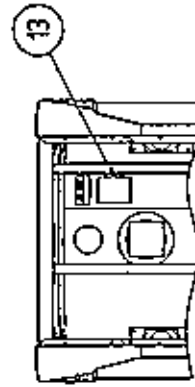

SEE C

TORQUE NB 195kgf·cm
M(4 SCR) 10kgf·cm

⑨ ASSY COCKPIT 1P (SPG-10001)

(0-2/2)

ITEM NO.	PART NO.	DESCRIPTION	NOTE
1	SPG-20001	ASSY MAIN BASE 1P	
2	SPG-1030	ASSY MONITOR COVER L 1P	
3	SPG-1035	ASSY MONITOR COVER R 1P	
4	SPG-12004	ASSY CONTROL PANEL TWIN ENG	
5	SPG-1004	MONITOR STAND	
6	SPG-1007	WIRE COVER BOX	
7	INY-1016	MONITOR SUPPORT	
8	SPG-1008	ROOF LID	
9	TTR-1067X	MONITOR MASK	
10	SPG-1005	MASK HOLDER	
11	DYN-1025	RUBBER CUSHION	
12	INY-1015	CRT ADJUST PANEL	
13	440-DS0013XEG	STICKER D MONITOR ENG	
101	220-5242-24-04	ASSY CLR DSPL 29 TYPE 100V	
	200-5243-24	ASSY CLR DSPL 29 TYPE 24K 100V	
102	280-5009-01	CORD CLAMP 21	
103	280-5275-SR10	CORD CLAMP SR10	
104	601-0460	PLASTIC TIE BELT 100 M/M	
105	280-5112	BUSH FOR TV	
106	280-5113	COLLAR FOR TV	
107	280-5114	SPACER 6.4-25×2	
108	280-5185-6	SPACER TUBE L=6	
109	601-6231-C100	EDGING NEW TYPE	
201	030-000850-SB	HEX BLT W/S BLK M8×50	
202	068-852216-0B	FLT WSHR BLK 8.5-22×1.6	
203	030-000840-SB	HEX BLT W/S BLK M8×40	
204	060-P00800-0B	FLT WSHR BLK M8	
205	008-B00830-0B	TMP PRF SCR BH BLK M8×30	
206	000-P00408-WB	M SCR PH W/FS BLK M4×8	
207	000-T00530-0B	M SCR TH BLK M5×30	
208	000-T00512-0B	M SCR TH BLK M5×12	
209	068-552016-0B	FLT WSHR BLK 5.5-20×1.6	
210	000-P00508	M SCR PH M5×8	
211	050-P00600	FLG NUT M6	
212	000-P00312-WB	M SCR PH W/FS BLK M3×12	
213	DYN-1019	FLT WASHER M8	
214	000-T00408-0B	M SCR TH BLK M4×8	
215	060-S00800-0B	SPR WSHR BLK M8	
301	600-6873-034	WIRE HARN FRONT SPEAKER	
302	600-6873-036	WIRE HARN MONITOR	
303	600-6873-038	WIRE HARN EXT CONT PNL B	
304	600-6873-039	WIRE HARN EXT ENCODER A	
305	600-6873-040	WIRE HARN EXT MOTOR A	
306	600-6873-041	WIRE HARN EXT AC	
307	600-6873-042	WIRE HARN EXT LAMP	
308	600-6873-049	WIRE HARN EXT VOLUME B	

⑩ ASSY MONITOR COVER L 1P (SPG-1030)

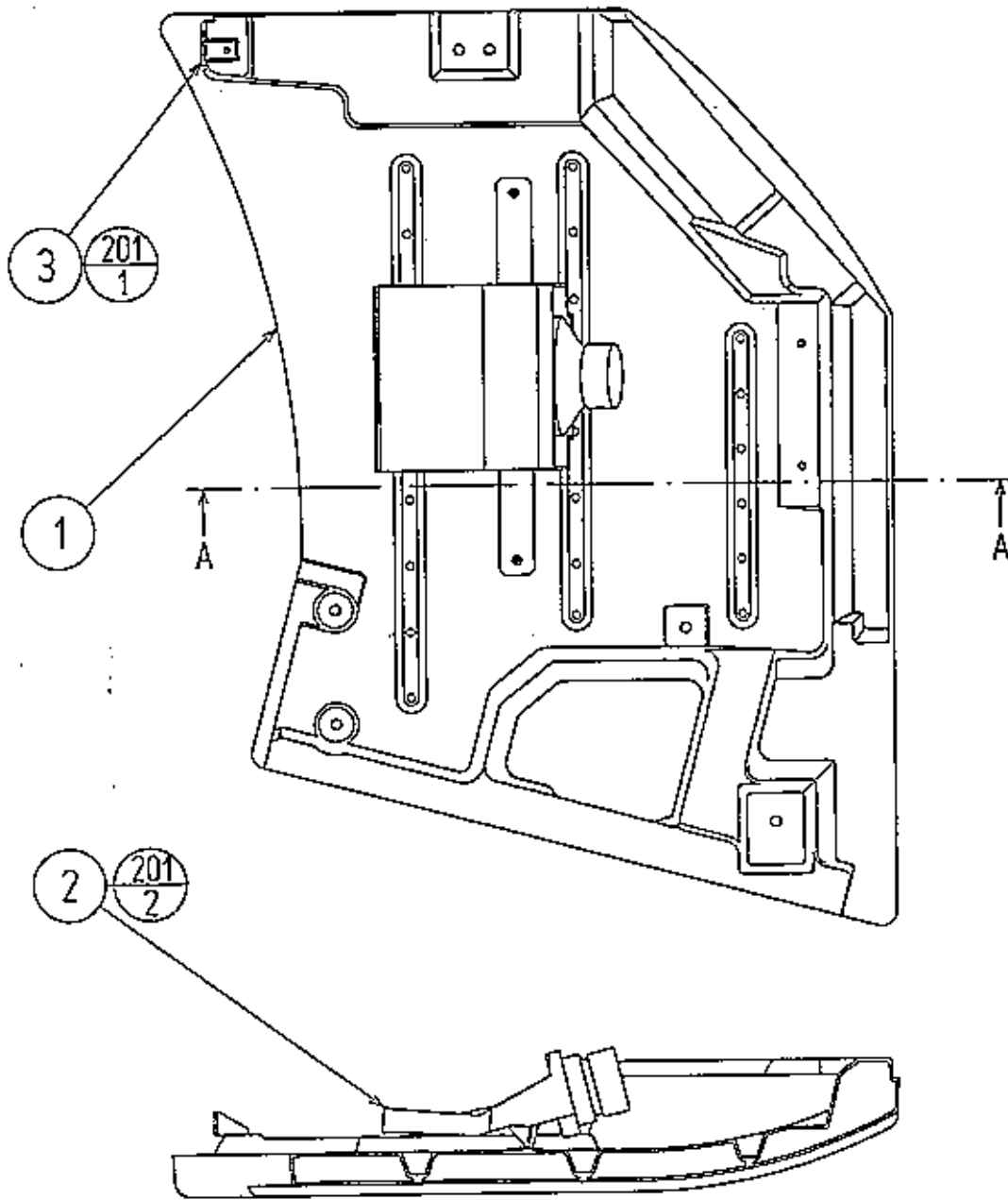

SECTION A-A

ITEM NO.	PART NO.	DESCRIPTION	NOTE
1	SPG-1031	COVER PANEL L 1P	
2	SPG-1100	ASSY SPBAKER	
3	DYN-1032	MASK BRKT	
201	000-P00408-W	M SCR PH W/FS M4×8	

①① ASSY MONITOR COVER R 1P (SPG-1035)

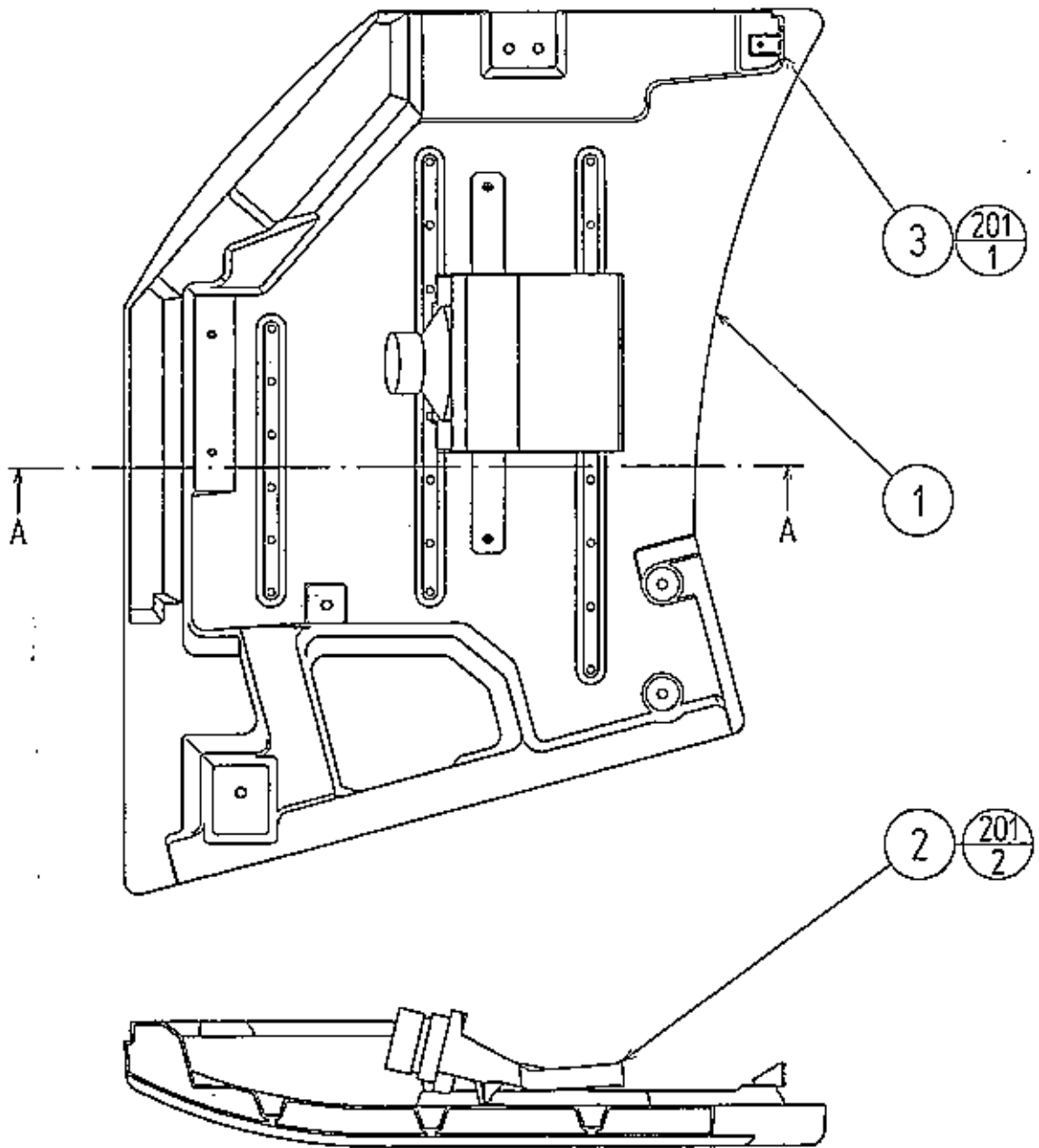

SECTION A-A

ITEM NO.	PART NO.	DESCRIPTION	NOTE
1	SPG-1046-A	COVER PANEL R BLANK	
2	SPG-1100	ASSY SPEAKER	
3	DYN-1032	MASK BRKT	
201	000-P00408-W	M SCR PH W/FS M4×8	

⑫ ASSY MONITOR COVER L 2P (SPG-1040)

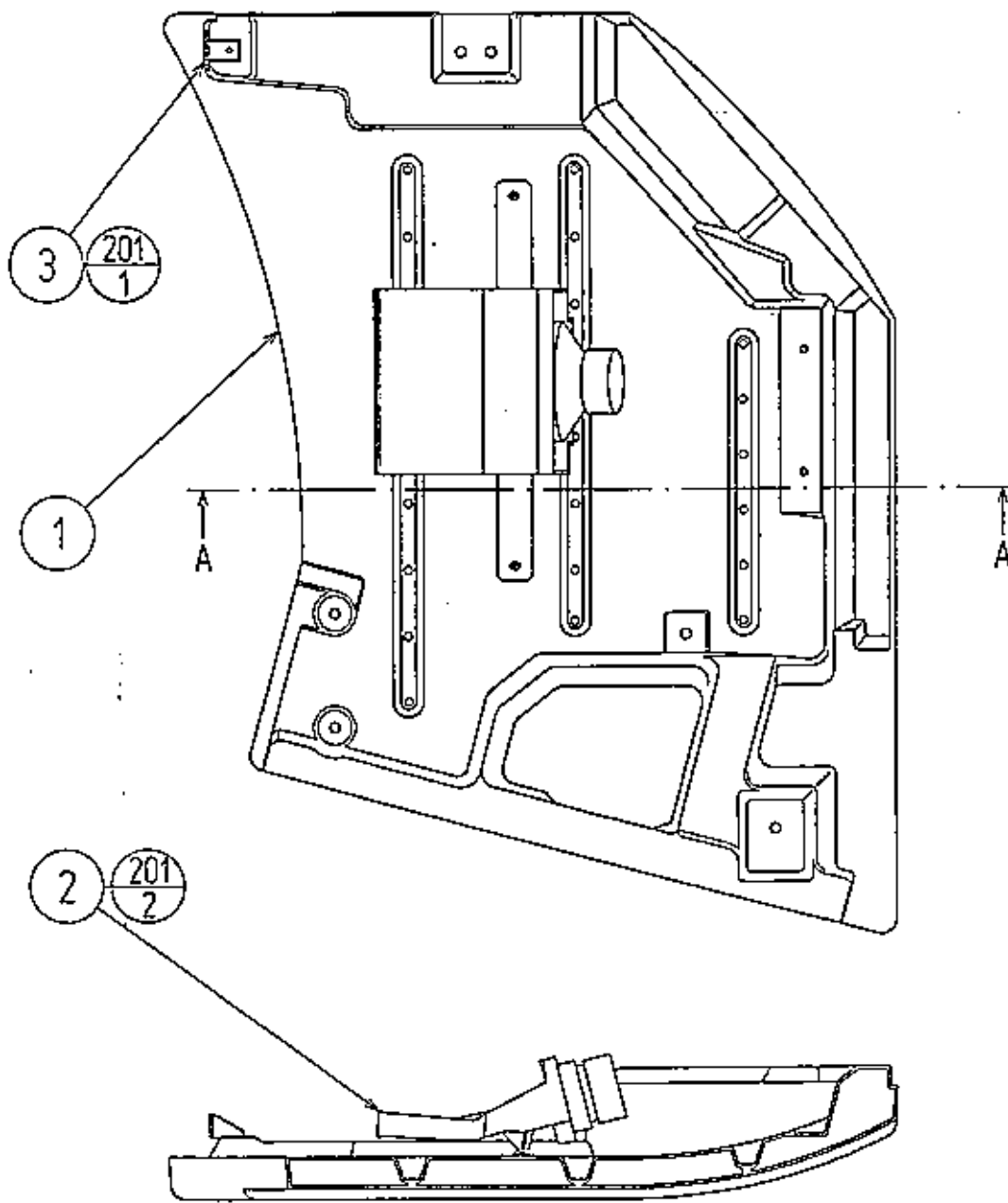

SECTION A-A

ITEM NO.	PART NO.	DESCRIPTION	NOTE
1	SPG-1031-A	COVER PANEL L BLANK	
2	SPG-1100	ASSY SPEAKER	
3	DYN-1032	MASK BRKT	
201	000-P00408-W	M SCR PH W/FS M4×8	

⑬ ASSY MONITOR COVER R 2P (SPG-1045)

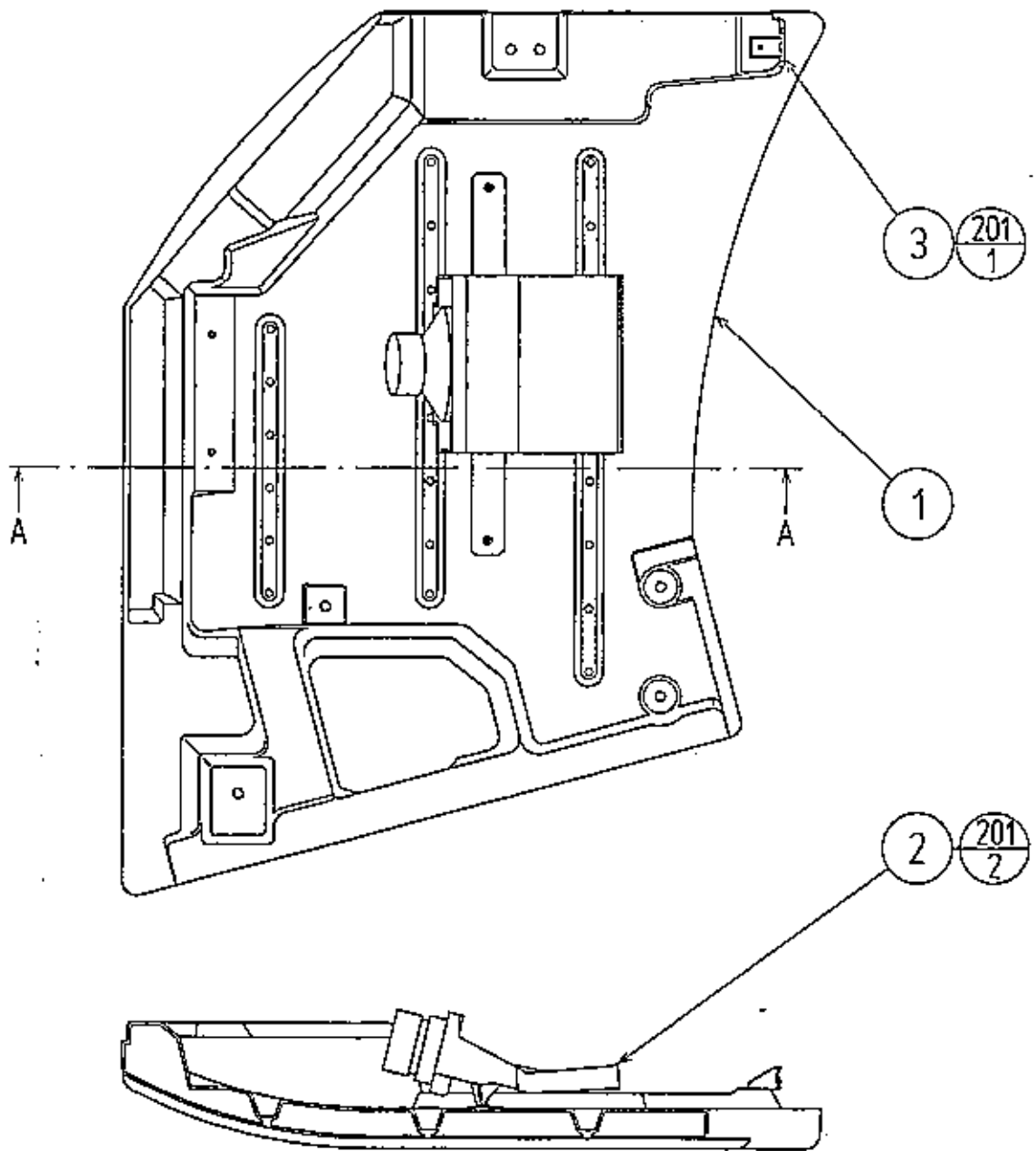

SECTION A-A

ITEM NO.	PART NO.	DESCRIPTION	NOTE
1	SPG-1046	COVER PANEL R 2P	
2	SPG-1100	ASSY SPEAKER	
3	DYN-1032	MASK BRKT	
201	000-P00408-W	M SCR PH W/FS M4×8	

⑭ ASSY SPEAKER (SPG-1100)

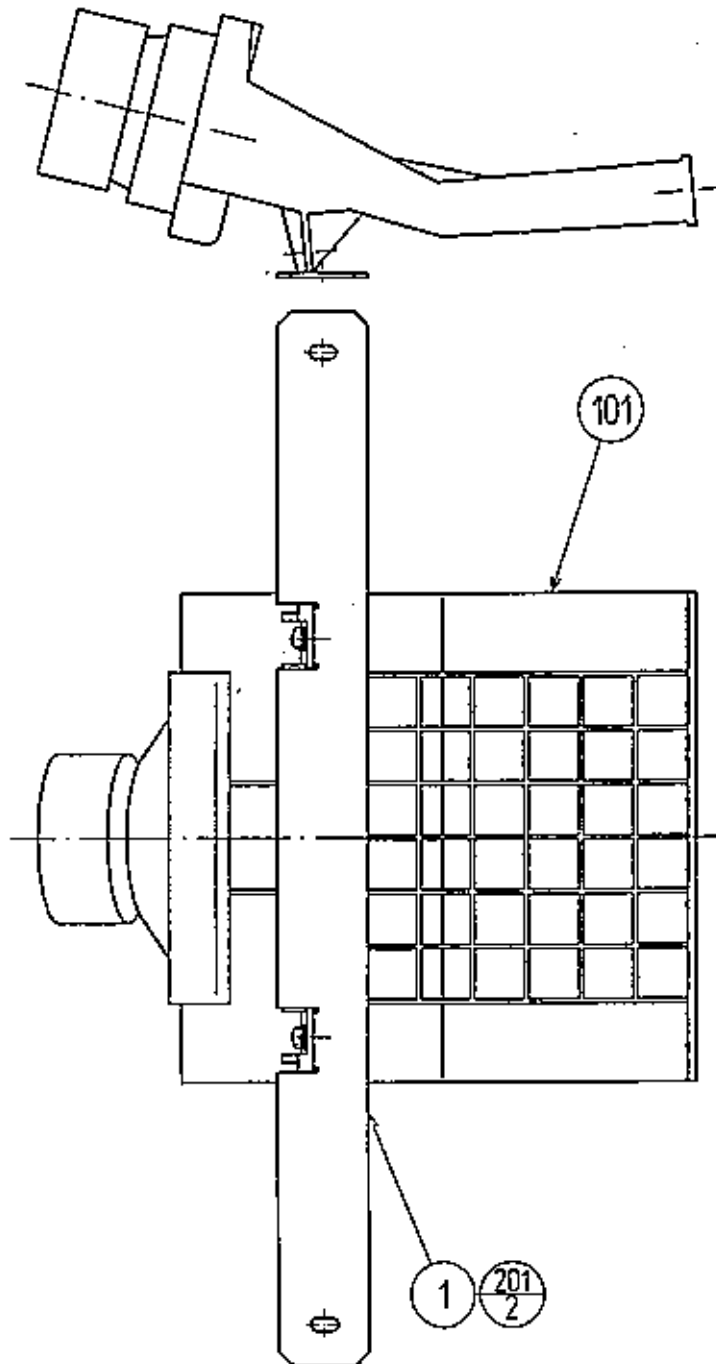

ITEM NO.	PART NO.	DESCRIPTION	NOTE
1	INY-1701	SPEAKER BRKT	
101	130-5152	SPKR BOX MINI DOME 12W	
201	000-P00412-W	M SCR PH W/FS M4×12	

⑮ ASSY COCKPIT 2P (SPG-11001)

(D-1/2)

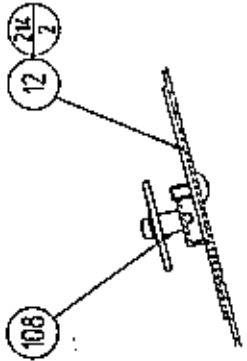
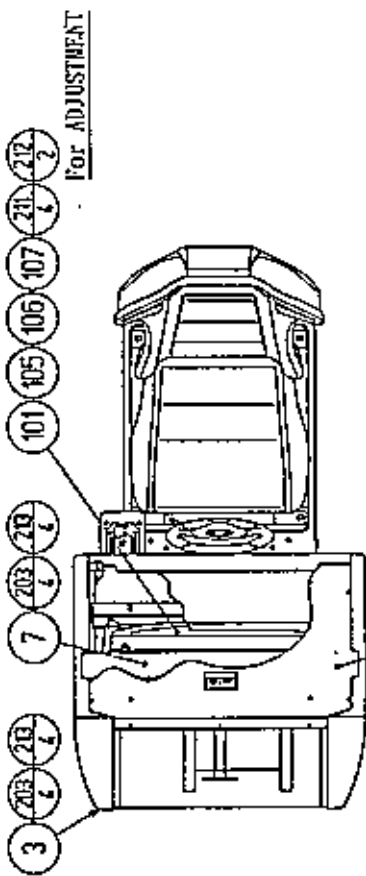

Details of PART B

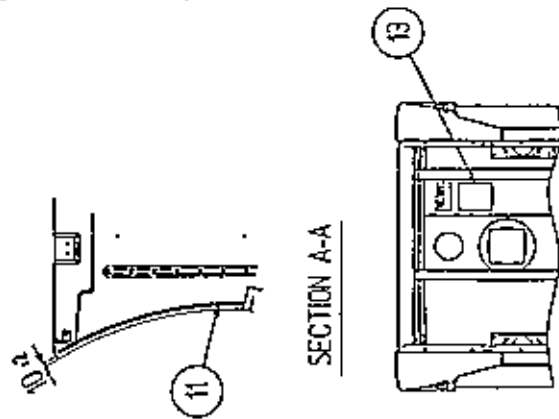

SEE C

TORQUE: MB 195kgf·cm
MA (K SCR) 10kgf·cm

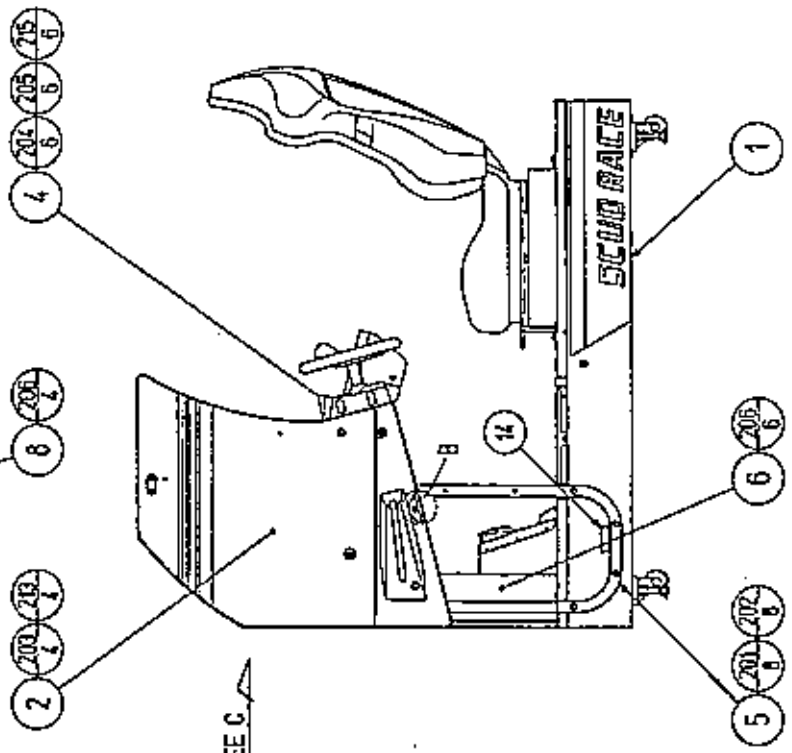
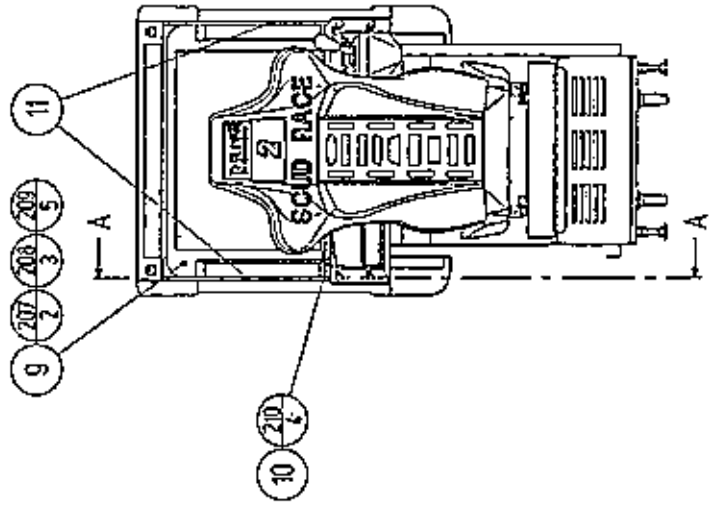

SEE C

⑮ ASSY COCKPIT 2P (SPG-11001)

(0-2/2)

ITEM NO.	PART NO.	DESCRIPTION	NOTE
1	SPG-21001	ASSY MAIN BASE 2P	
2	SPG-1040	ASSY MONITOR COVER L 2P	
3	SPG-1045	ASSY MONITOR COVER R 2P	
4	SPG-12004	ASSY CONTROL PANEL TWIN ENG	
5	SPG-1004	MONITOR STAND	
6	SPG-1007	WIRE COVER BOX	
7	INY-1016	MONITOR SUPPORT	
8	SPG-1008	ROOF LID	
9	TTR-1067X	MONITOR MASK	
10	SPG-1005	MASK HOLDER	
11	DYN-1025	RUBBER CUSHION	
12	INY-1015	CRT ADJUST PANEL	
13	440-DS0013XEG	STICKER D MONITOR ENG	
101	200-5242-24-04	ASSY CLR DSPL 29 TYPE 100V	
	200-5243-24	ASSY CLR DSPL 29 TYPE 24K 100V	
102	280-5009-01	CORD CLAMP 21	
103	280-5275-SR10	CORD CLAMP SR10	
104	601-0460	PLASTIC TIE BELT 100 M/M	
105	280-5112	BUSH FOR TV	
106	280-5113	COLLAR FOR TV	
107	280-5114	SPACER 6.4-25×2	
108	280-5185-6	SPACER TUBE L=6	
109	601-6231-C100	EDGING NEW TYPE	
201	030-000850-SB	HEX BLT W/S BLK M8×50	
202	068-852216-0B	FLT WSHR BLK 8.5-22×1.6	
203	030-000840-SB	HEX BLT W/S BLK M8×40	
204	060-F00800-0B	FLT WSHR BLK M8	
205	008-B00830-0B	TMP PRF SCR BH BLK M8×30	
206	000-P00408-WB	M SCR PH W/FS BLK M4×8	
207	000-T00530-0B	M SCR TH BLK M5×30	
208	000-T00512-0B	M SCR TH BLK M5×12	
209	068-552016-0B	FLT WSHR BLK 5.5-20×1.6	
210	000-F00508	M SCR FH M5×8	
211	050-F00600	FLG NUT M6	
212	000-P00312-WB	M SCR PH W/FS BLK M3×12	
213	DYN-1019	FLT WASHER M8	
214	000-T00408-0B	M SCR TH BLK M4×8	
215	060-S00800-0B	SPR WSHR BLK M8	
301	600-6873-034	WIRE HARN FRONT SPEAKER	
302	600-6873-036	WIRE HARN MONITOR	
303	600-6873-038	WIRE HARN EXT CONT PNL B	
304	600-6873-039	WIRE HARN EXT ENCODER A	
305	600-6873-040	WIRE HARN EXT MOTOR A	
306	600-6873-041	WIRE HARN EXT AC	
307	600-6873-042	WIRE HARN EXT LAMP	
308	600-6873-049	WIRE HARN EXT VOLUME B	

16 ASSY CONTROL PANEL TWIN ENG (SPG-12004)

(D-1/2)

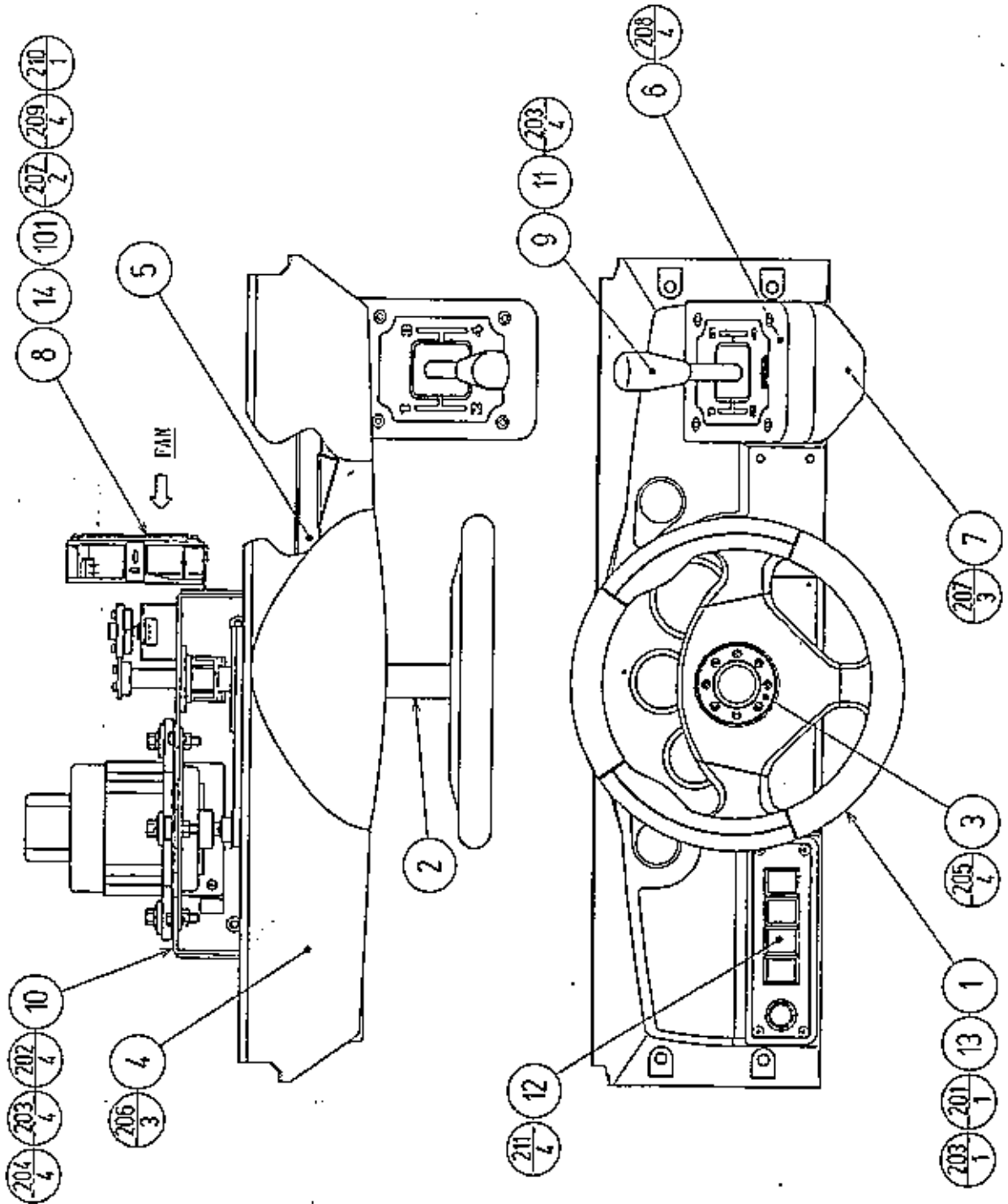

TORQUE 200kgf·cm

① ASSY CONTROL PANEL TWIN ENG (SPG-12004)

(0-2/2)

ITEM NO.	PART NO.	DESCRIPTION	NOTE
1	SPG-2001	STEERING WHEEL	
2	DYN-1209X	HANDLE COLLAR	
3	SPG-2002	STEERING EMBLEM	
4	SPG-1201-01	CONTROL PANEL COVER ENG	
	SPG-1201X-01	CONTROL PANEL COVER ENG	
5	SPG-1205	CONTROL PANEL BRKT	
6	DYN-1222	SHIFT COVER A	
7	DYN-1223X	SHIFT COVER B	
8	SPG-1203	FAN BRKT	
9	SPG-1204	SPL BLT M8	
10	SPG-2500	ASSY HANDLE MECHA	
11	SPG-2150	ASSY 4 SPEED SHIFTER	
12	DYN-1290	ASSY VIRTUAL BUTTON TWIN	
13	SPG-2039	SPACER RING	
14	601-8543	FAN GUARD	
101	260-0011-02	AXIAL FLOW FAN AC100V 50-60HZ	
102	601-0460	PLASTIC TIE BELT 100 M/M	
103	280-5009-01	CORD CLAMP 21	
104	280-0419	HARNESS LUG	
105	280-5275-SR10	CORD CLAMP SR10	
201	020-000820-02	HEX SKT H CAP SCR BLK OZ M8×20	
202	060-F00800	FLT WSHR M8	
203	060-S00800	SPR WSHR M8	
204	050-H00800	HEX NUT M8	
205	FAS-200013	HEX SKT H CAP SCR CRM M4×16	
206	000-T00416-0B	M SCR TH BLK M4×16	
207	000-P00412-W	M SCR PH W/FS M4×12	
208	000-T00412-0B	M SCR TH BLK M4×12	
209	000-P00312-W	M SCR PH W/FS M3×12	
210	050-F00300	FLG NUT M3	
211	000-T00412-0C	M SCR TH CRM M4×12	
212	000-P00408-W	M SCR PH W/FS M4×8	
213	010-P00406-F	S-TITE SCR PH W/F M4×6	
301	600-6873-043	WIRE HARN VIEW BUTTON	
302	600-6873-044	WIRE HARN EXT SHIFTER	
303	600-6873-045	WIRE HARN EXT ENCODER B	
304	600-6873-046	WIRE HARN EXT MOTOR B	
305	600-6873-047	WIRE HARN CONT PNL FAN	
306	600-6873-050	WIRE HARN EXT VOLUME C	
307	600-6873-073	WIRE HARN BARTH MOTOR	

17 ASSY 4 SPEED SHIFTER (SPG-2150)

(D-1/2)

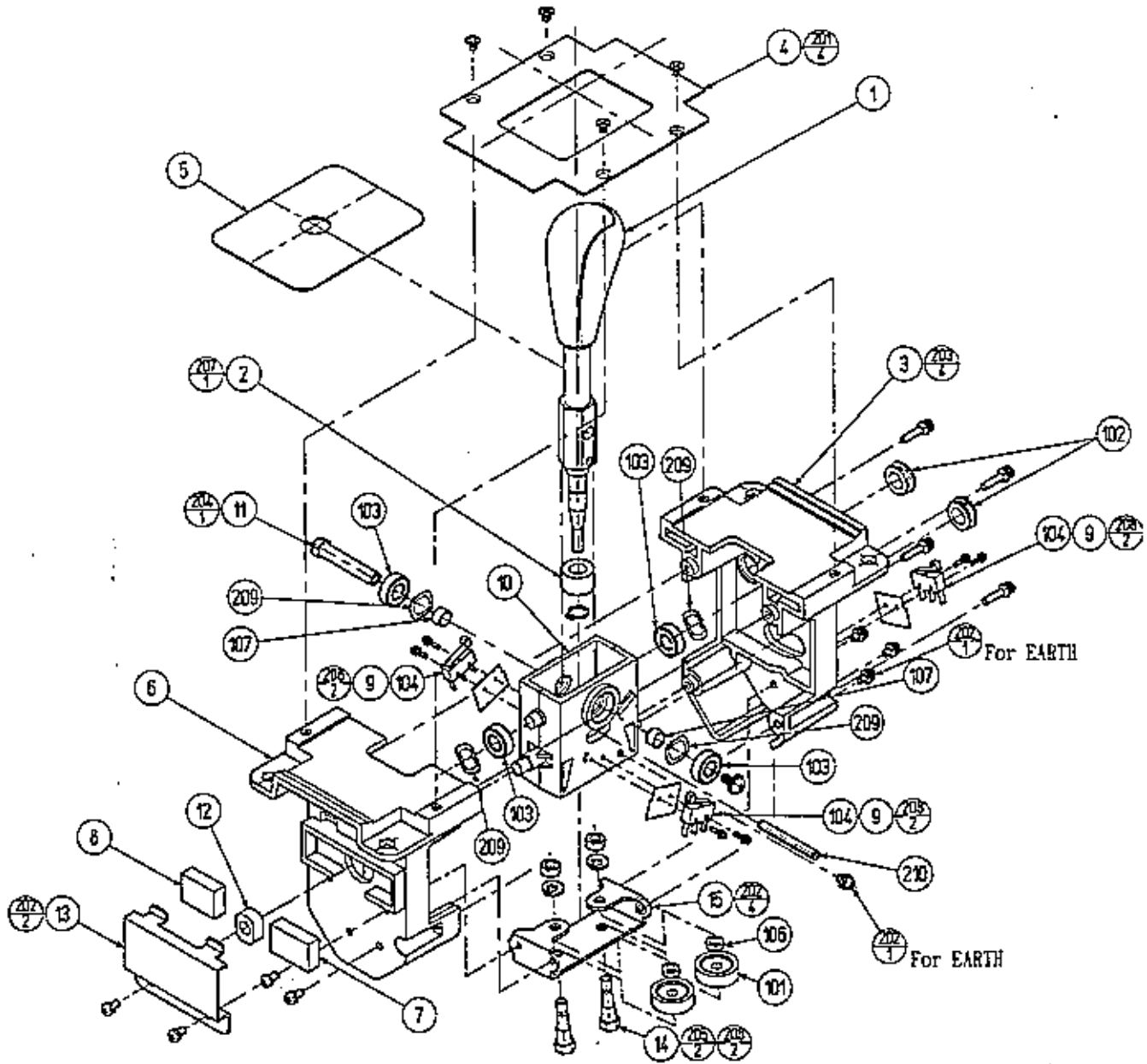

(17) ASSY 4 SPEED SHIFTER (SPG-2150)

(D-2/2)

ITEM NO.	PART NO.	DESCRIPTION	NOTE
1	SPG-2151	SHIFT KNOB	
2	SPG-2152	STOPPER RUBBER	
3	SPG-2153	FRONT BASE	
4	SPG-2154	SLIDE COVER	
5	SPG-2155	SLIDE PLATE	
6	SPG-2156	RBAR BASE	
7	SPG-2157	RUBBER BLOCK 45	
8	SPG-2158	RUBBER BLOCK 65	
9	SPG-2159	INSULATOR SHEET	
10	SPG-2160	SHAFT CASE	
11	SPG-2161	SHAFT BOLT	
12	SPG-2162	CENTERING BLOCK	
13	SPG-2163	RUBBER CASE	
14	SPG-2164	ROLLER BOLT	
15	SPG-2165	ROLLER SUPPORT	
101	100-5252	BEARING ROLLER 25	
102	100-5193	GROMMET 11	
103	100-5170	BEARING 8	
104	509-5636	SW MICRO TYPE SS-5GL2T	
105	601-0460	PLASTIC TIE BELT 100M/M	
106	280-5306	SPACER FAI 6×30	
107	280-5307	SPACER FAI 8×55	
108	280-5251	SELF MOUNT TIE 2.5	
201	000-F00406	M SCR FH M4×6	
202	000-P00410-W	M SCR PH W/FS M4×10	
203	000-P00420-W	M SCR PH W/FS M4×20	
204	000-P00508-W	M SCR PH W/FS M5×8	
205	050-H00600	HEX NUT M6	
206	060-S00600	SPR WSHR M6	
207	065-S01050-Z	STP RING BLK OZ S10	
208	FAS-000033	M SCR PH W/FS M2.3×12	
209	FAS-650008	WAVE WSHR 12.7-18.1×2.5	
210	FAS-450006	SPR PIN WAVE STN 5×45	
301	600-6445-45	WIRE HARN SHIFT MECHA	
302	600-6872	WIRE HARN EARTH SHIFT MECHA	

18 ASSY HANDLE MECHA (SPG-2500)

(D-1/2)

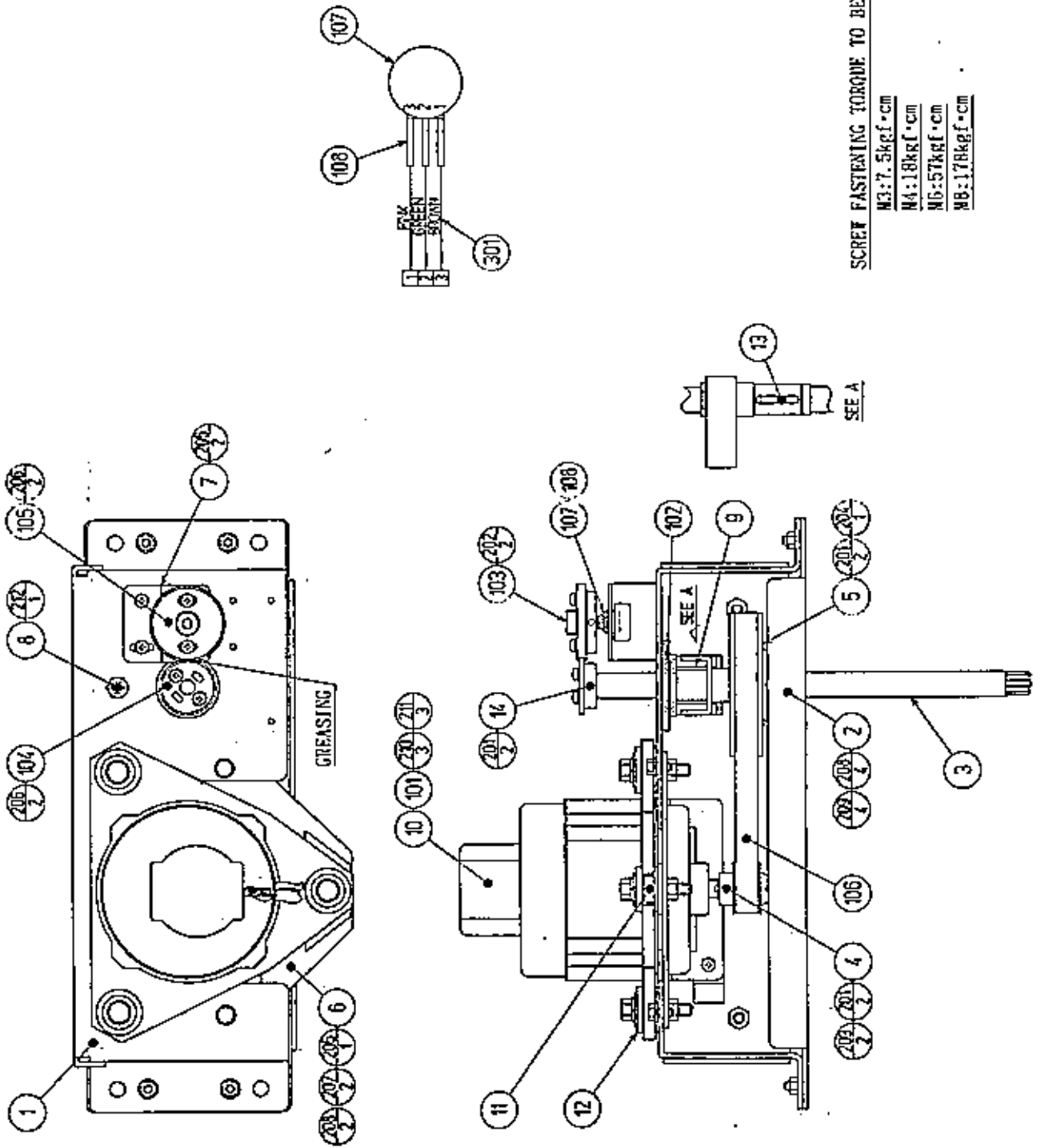

⑱ ASSY HANDLE MECHA (SPG-2500)

(D-2/2)

ITEM NO.	PART NO.	DESCRIPTION	NOTE
1	SPG-2501	HANDLE BASE	
2	SPG-2502	BASE LID	
3	SPG-2503	HANDLE SHAFT	
4	SPG-2504	PULLEY 20 S5M	
5	SPG-2505	PULLEY 60 S5M	
6	SPG-2506	MOTOR BRKT	
7	SPG-2507	VR BRKT	
8	SPG-2108	STOPPER BOLT	
9	SPG-2109	STOPPER RUBBER	
10	SPG-2453	KEY 4×4×40	
11	ASK-3502	MOTOR SPACER	
12	ASK-3503	MOTOR COLLAR	
13	DYN-1270	STOPPER KEY	
14	SLC-1130	ADJUST RING	
101	350-5448	SERVO MOTOR 500W SPG	
102	100-5112	BEARING 17	
103	601-8966	GEAR HOLDER	
104	601-6172	GEAR 48	
105	601-6959	GEAR 64	
106	601-9173	TIMING BELT	
107	220-5484	VOL CONT B-5K OHM	
	220-5373	VOL CONT B-5K	
108	310-5029-F20	SUMITUBE FF 20MM	
201	028-A00408-P	SET SCR HEX SKT CUP P M4×8	
202	028-A00308-P	SET SCR HEX SKT CUP P M3×8	
203	065-S012S0-Z	STP RING BLK OZ S12	
204	065-S020S0-Z	STP RING BLK OZ S20	
205	000-P00408-W	M SCR PH W/FS M4×8	
206	000-P00412-W	M SCR PH W/FS M4×12	
207	030-000612-S	HEX BLT W/S M6×12	
208	060-F00600	FLT WSHR M6	
209	050-U00600	U NUT M6	
210	030-000840-S	HEX BLT W/S M8×40	
211	068-852216	FLT WSHR 8.5-22×1.6	
212	050-U00800	U NUT M8	
301	600-6866	WIRE HARN ASSY HANDLE MECHA VR	

① ASSY VIRTUAL BUTTON TWIN (DYN-1290)

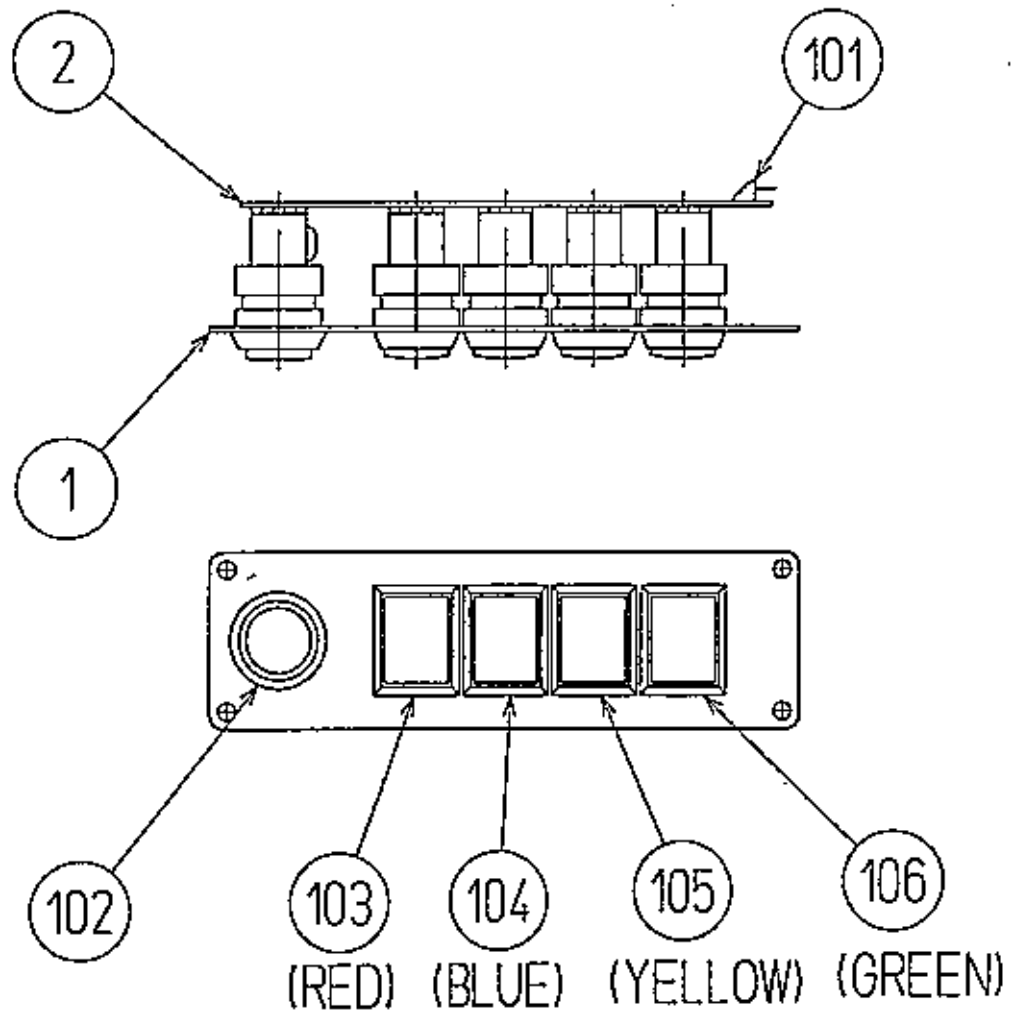

ITEM NO.	PART NO.	DESCRIPTION	NOTE
1	DYN-1291	VR BUTTON BRKT	
2	171-6478B	PC BD LIGHTING SW×5	
101	212-5205-12	CONN JST M 12P RTA	
102	509-5560-Y	PB SW W/L 6V 1L Y	YELLOW
103	509-5561-R	PB SW W/L 6V 5L R	RED
104	509-5561-S	PB SW W/L 6V 5L S	BLUE
105	509-5561-Y	PB SW W/L 6V 5L Y	YELLOW
106	509-5561-G	PB SW W/L 6V 5L G	GREEN

②⑩ ASSY BASE BOX (SPG-1500)

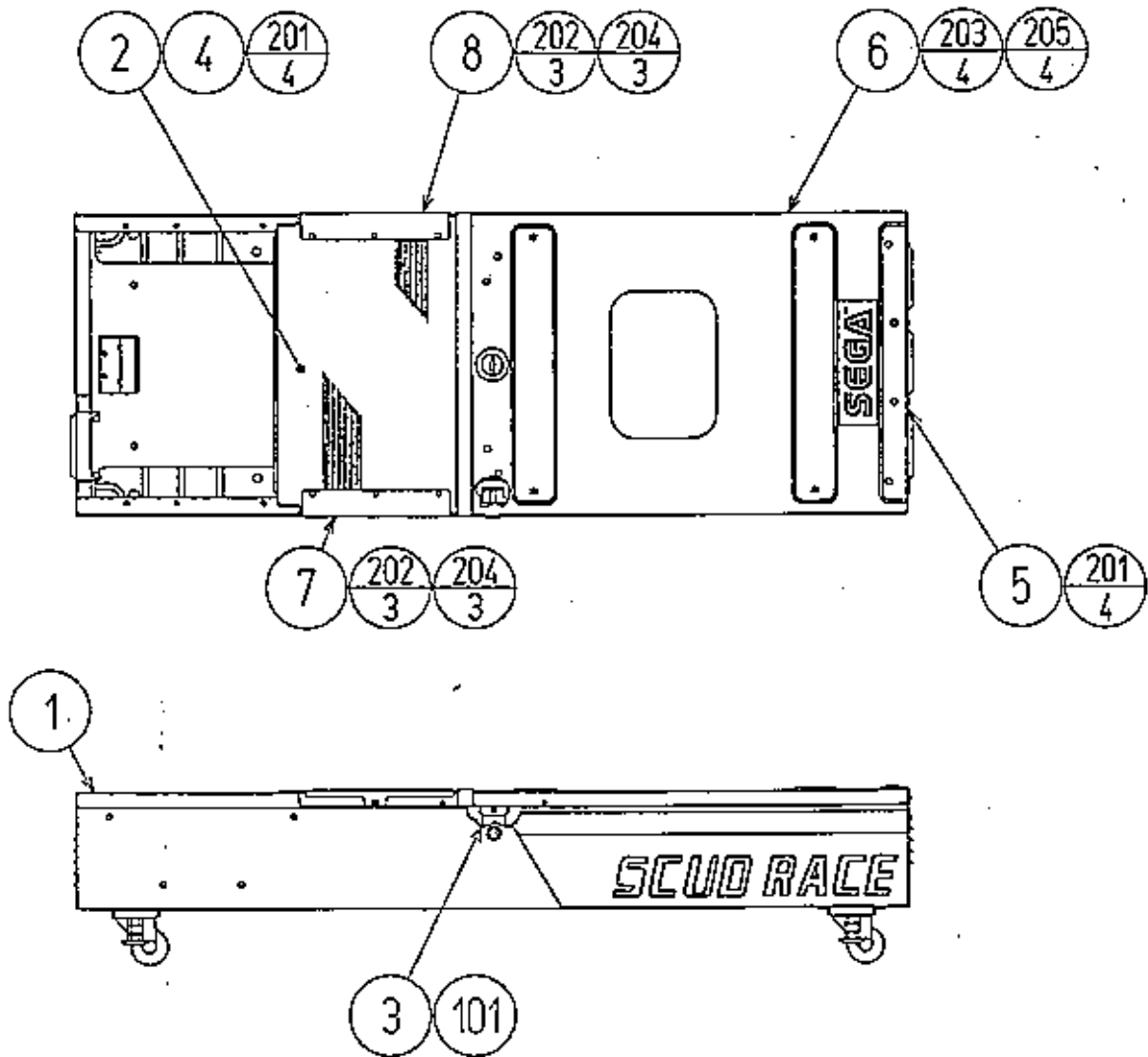

ITEM NO.	PART NO.	DESCRIPTION	NOTE
1	SPG-1501	MAIN BASE	
2	DYN-2003	BASE LID F	
3	DYN-2004	LOCK TNG	
4	DYN-2005X	FLOOR MAT	
5	DYN-2006	HINGE 480	
6	SPG-1510	ASSY BASE LID R	
7	DYN-2007X	LID EDGE L	
8	DYN-2009X	LID EDGE R	
101	220-5575	CAM LOCK MASTER W/O KEY	
201	000-T00512-0B	M SCR TH BLK M5×12	
202	031-000414-0C	CRG BLT CRM M4×14	
203	031-000514-0B	CRG BLT BLK M5×14	
204	050-F00400	FLG NUT M4	
205	050-F00500	FLG NUT M5	

②① MAIN BASE (SPG-1501)

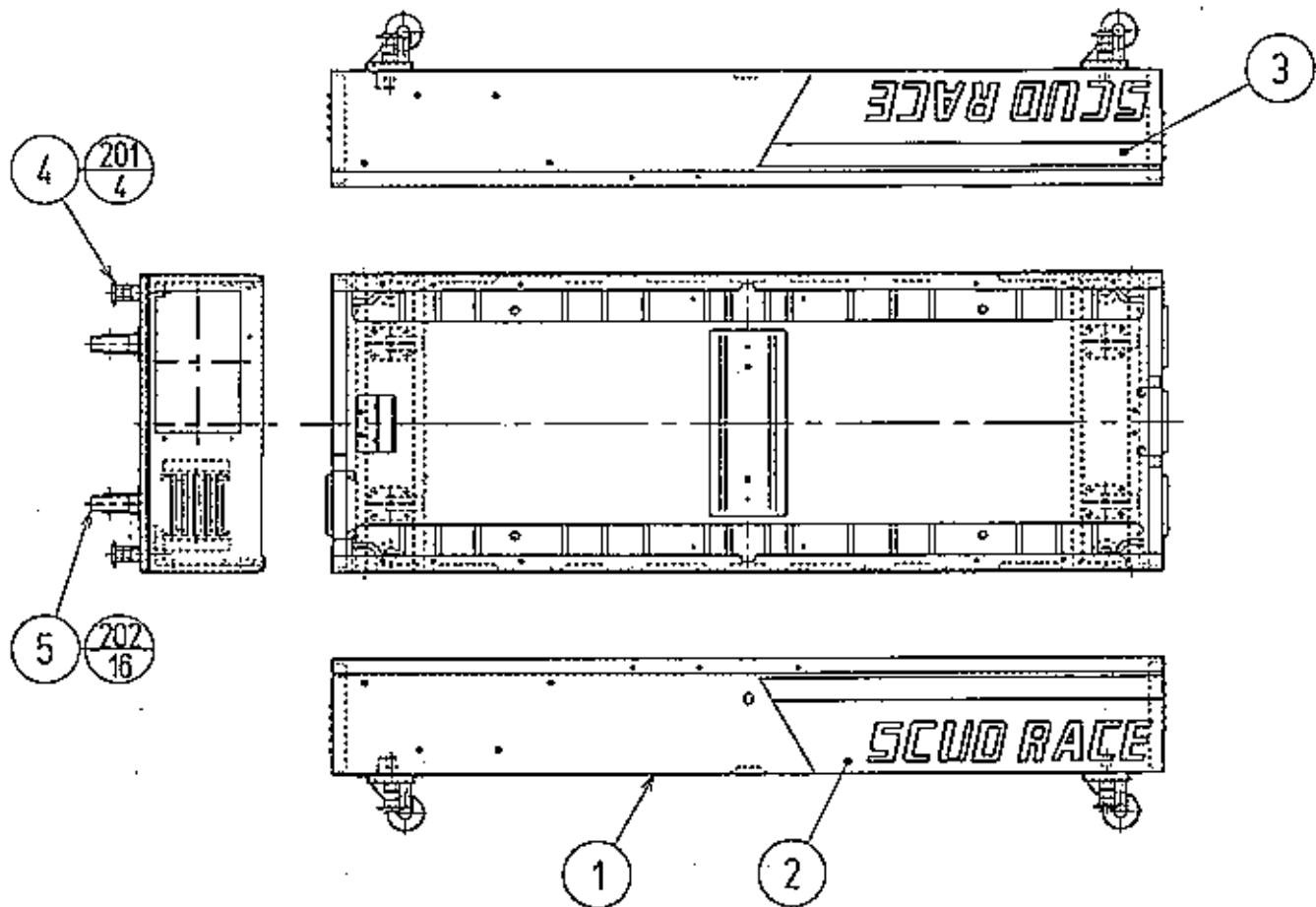

ITEM NO.	PART NO.	DESCRIPTION	NOTE
1	DYN-2002X-A	MAIN BASE BLANK	
2	SPG-1501-A	STICKER BASE L	
3	SPG-1501-B	STICKER BASE R	
4	601-5699X	LEG ADJUSTER BOLT M16×75	
5	601-5471	CASTER	
201	050-H01600-0B	HEX NUT BLK M16	
202	030-000816-S	HEX BLT W/S M8×16	

② ASSY BASE LID R (SPG-1510)

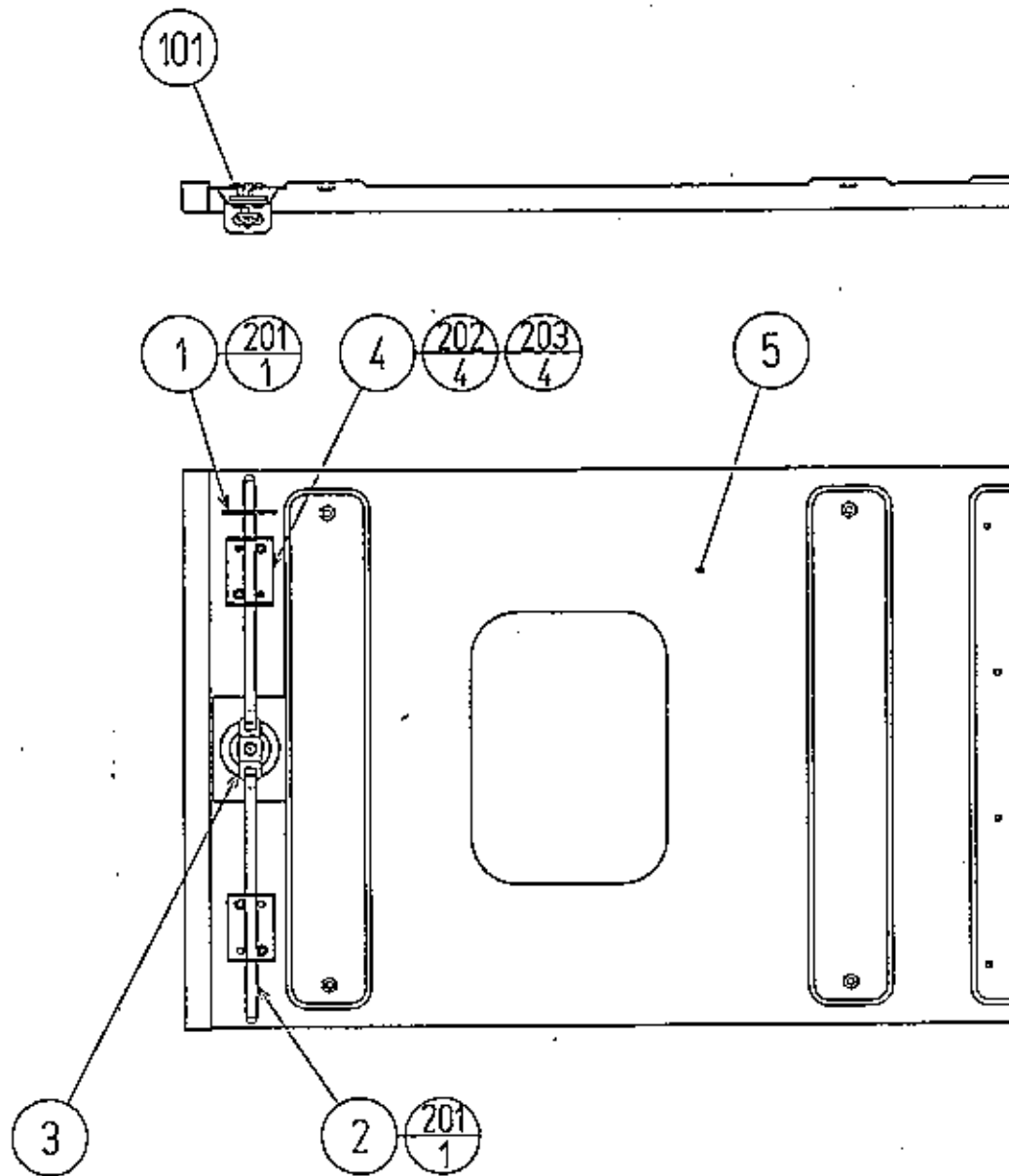

ITEM NO.	PART NO.	DESCRIPTION	NOTE
1	DYN-2011	LOCK ROD A	
2	DYN-2012	LOCK ROD B	
3	DYN-2013	LOCK ARM	
4	DYN-2014	ROD HOLDER	
5	SPG-1511	BASE LID R	
101	601-7551	LOCK HANDLE	
102	601-6231-C170	EDGING NEW TYPE	
103	280-5275-SR10	CORD CLAMP SR10	
201	045-C02520	COT PIN 2.5×20	
202	031-000510-08	CRG BLT BLK M5×10	
203	050-F00500	FLG NUT M5	

②③ BASE LID R (SPG-1511)

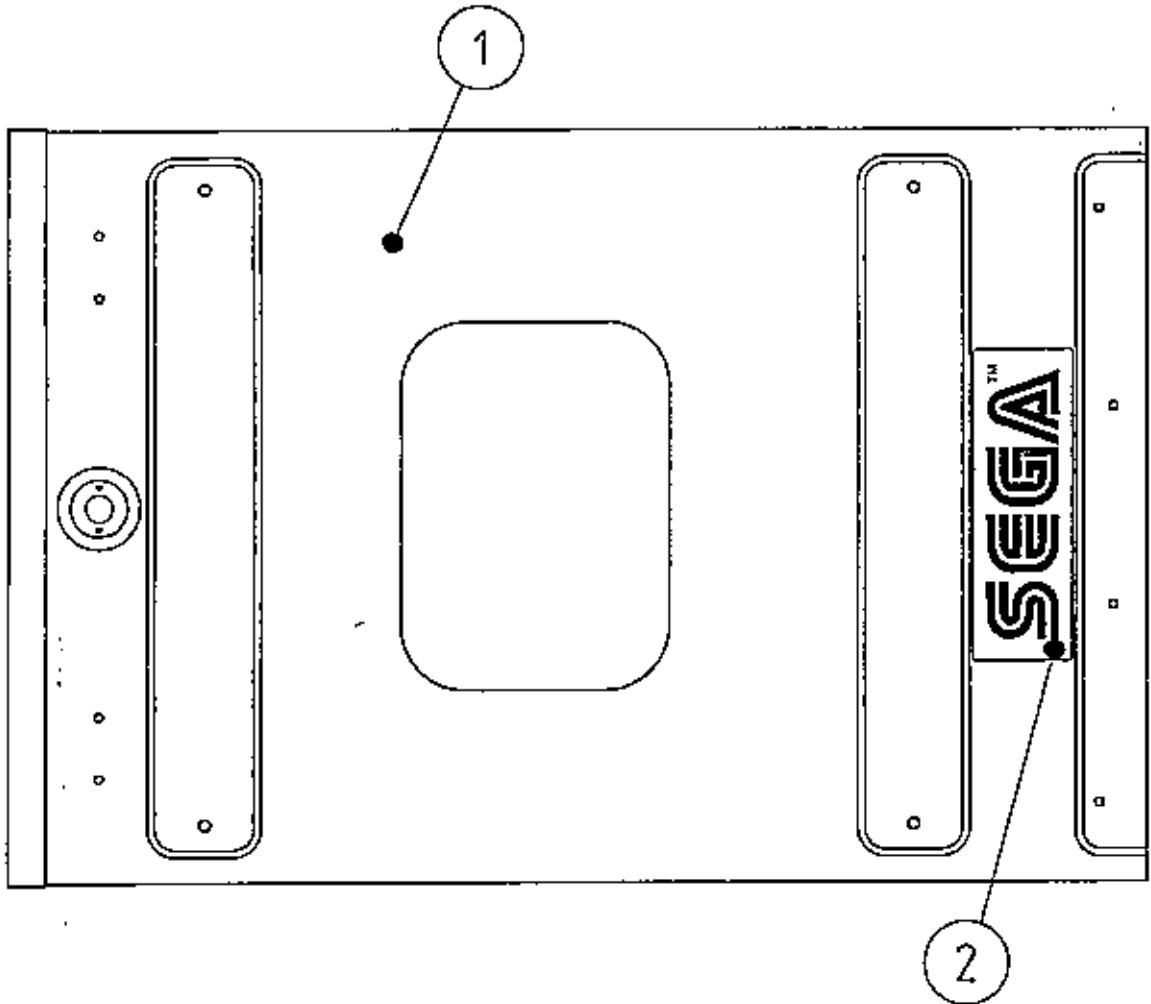

ITEM NO.	PART NO.	DESCRIPTION	NOTE
1	SPG-1511-A	BASE LID R BLANK	
2	SPG-1511-B	STICKER BASE LID R	

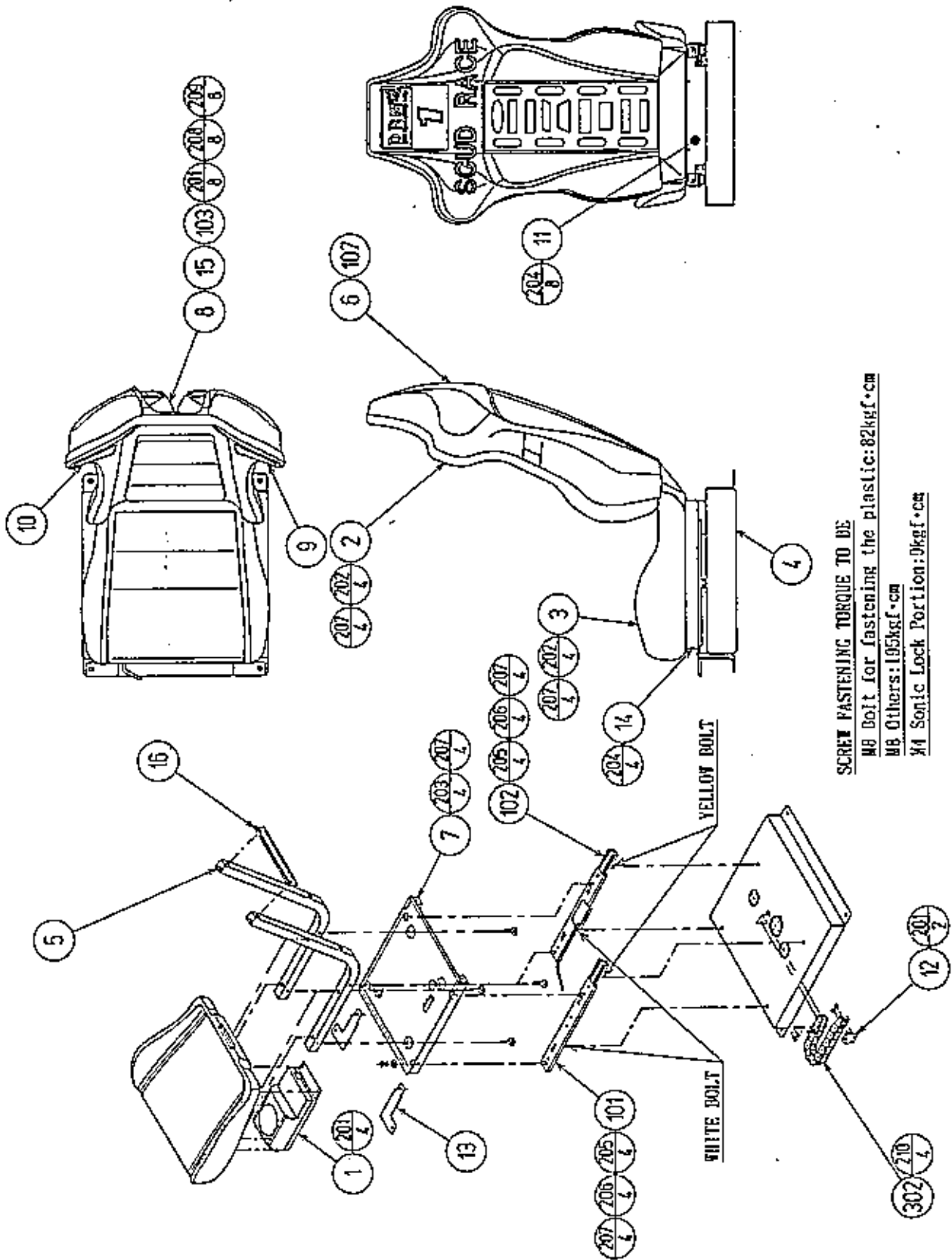

②4 ASSY SEAT TWIN 1P (SPG-1600)

(D-2/2)

ITEM NO.	PART NO.	DESCRIPTION	NOTE
1	STC-1650	ASSY WOOFER	
2	SPG-2401	UPPER SEAT	
3	SPG-2402	LOWER SEAT	
4	STC-2201	SEAT BASE	
5	STC-1604	SEAT FRAME	
6	SPG-2405	SEAT REAR COVER	
7	STC-1606	SEAT MOUNT TRAY	
8	STC-1607	SP MOUNT BRKT	
9	STC-1608	SPEAKER NET L	
10	STC-1609	SPEAKER NET R	
11	STC-1610	SAFETY GUARD	
12	STC-1611	CABLE BEAR BRKT	
13	STC-1612	PROTECT RUBBER	
14	STC-1613	SAFETY GUARD F	
15	INY-1302-B	MASK CUSHION SIDE	
16	SPG-2404	SEAT FRAME BRKT	
101	601-9059	SEAT RAIL L	
102	601-9060	SEAT RAIL R	
103	130-5159	GULL BOX SPEAKER 8OHM 5W	
104	280-5009-01	CORD CLAMP 21	
105	601-6563-188	BUSH 2.4T	
106	601-6563-100	BUSH 2.4T	
107	280-5297	SCRIVET 8 1K31	
108	280-5275-SR10	CORD CLAMP SR10	
201	000-P00410-W	M SCR PH W/FS M4×10	
202	030-000850-S	HEX BLT W/S M8×50	
203	030-000816-S	HEX BLT W/S M8×16	
204	000-T00408-0B	M SCR TH BLK M4×8	
205	050-H00800	HEX NUT M8	
206	060-S00800	SPR WSHR M8	
207	068-852216	FLT WSHR 8.5-22×1.6	
208	012-P00412	TAP SCR #2 PH 4×12	
209	060-F00400	FLT WSHR M4	
210	000-T00616-0B	M SCR TH BLK M6×16	
211	010-P00408-F	S-TITE SCR PH W/F M4×8	
301	600-6774-016	WIRE HARN SPEAKER EXT	
302	600-6774-017	WIRE HARN SEAT EXT	

25 ASSY WOOFER (STC-1650)

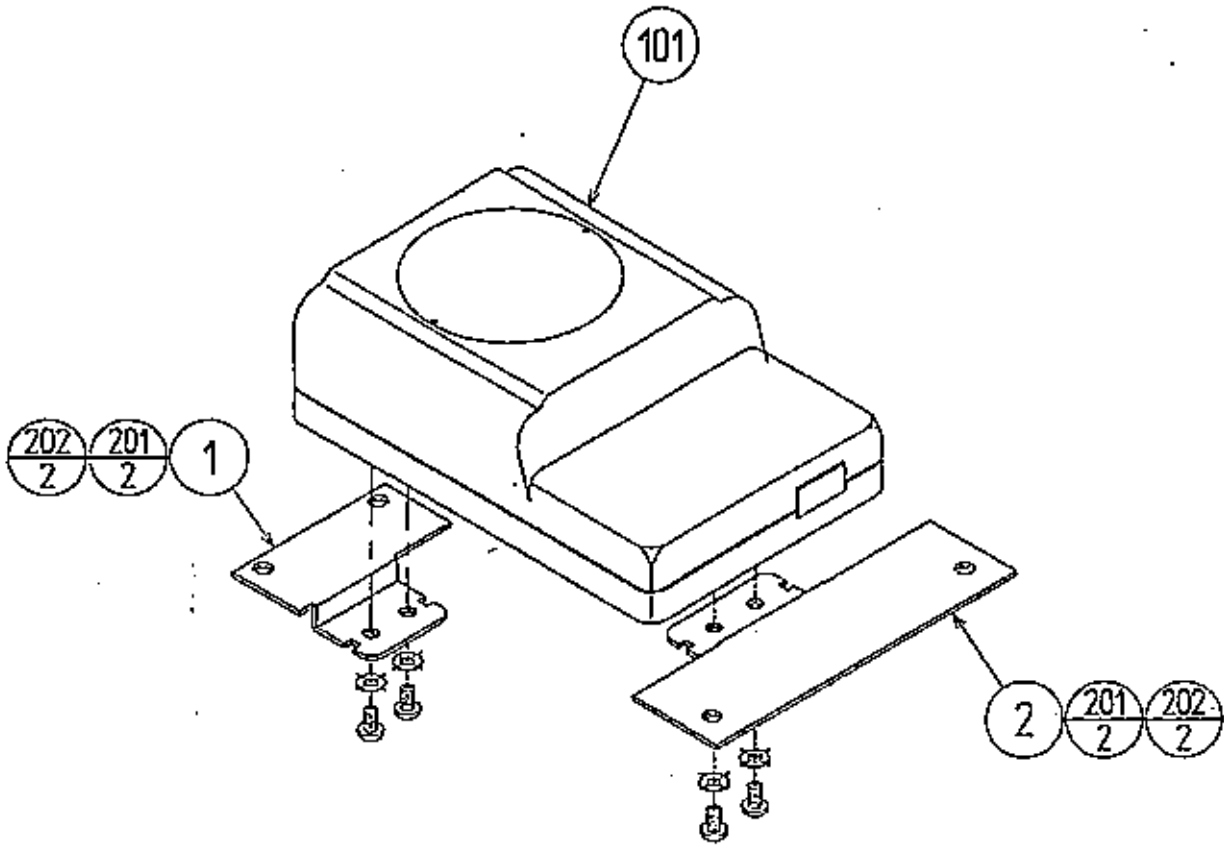

TORQUE: Under 10kgf-cm

ITEM NO.	PART NO.	DESCRIPTION	NOTE
1	STC-1651	WOOFER BRKT F	
2	STC-1652	WOOFER BRKT R	
101	130-5160	SUB WOOFER 4 OHM 30W	
201	012-P00412	TAP SCR #2 PH 4x12	
202	060-F00400	FLT WSHR M4	

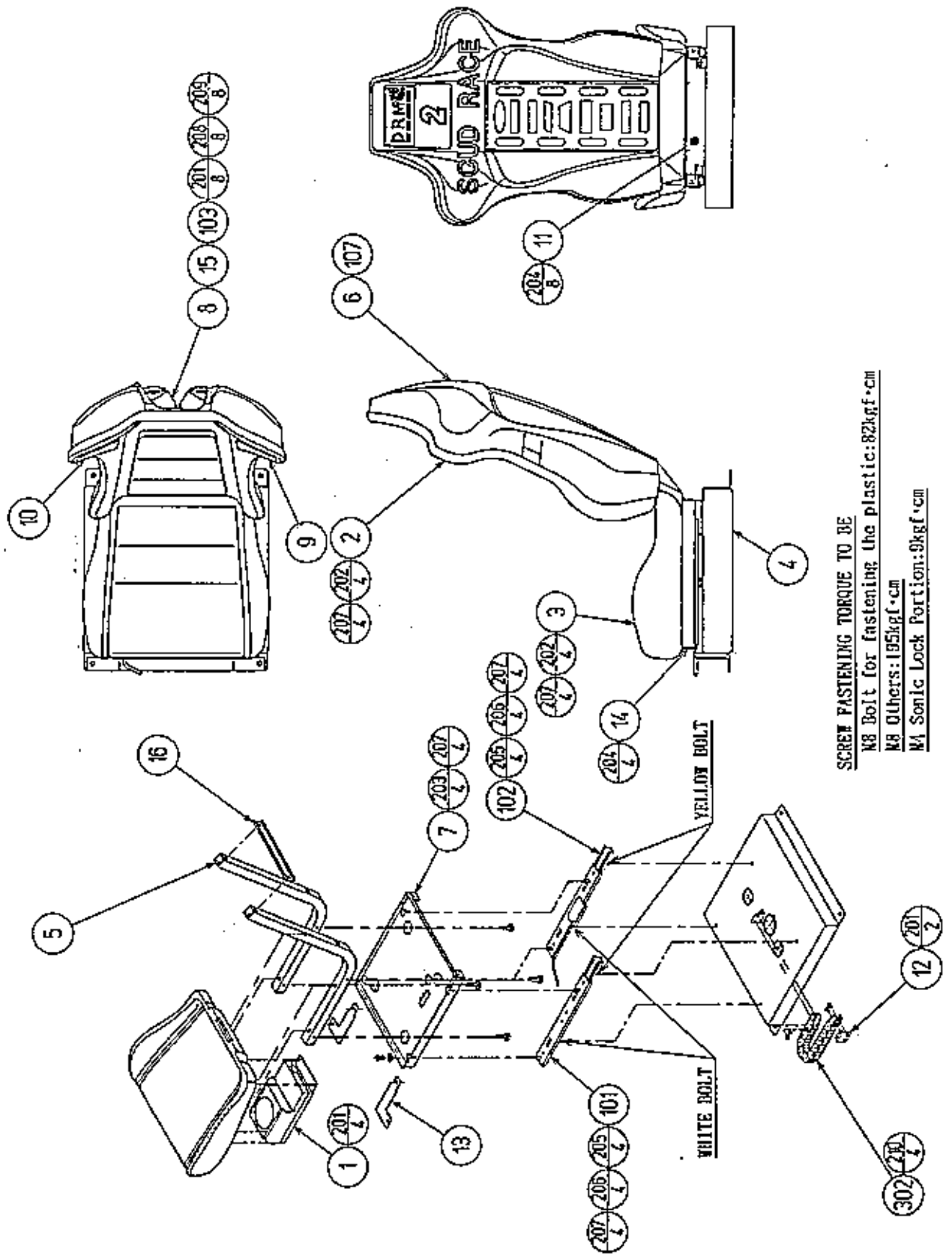

② ASSY SEAT TWIN 2P (SPG-1700)

(D-2/2)

ITEM NO.	PART NO.	DESCRIPTION	NOTE
1	STC-1650	ASSY WOOFER	
2	SPG-2401	UPPER SEAT	
3	SPG-2402	LOWER SEAT	
4	STC-2201	SEAT BASE	
5	STC-1604	SEAT FRAME	
6	SPG-1701	SEAT REAR COVER 2P	
7	STC-1606	SEAT MOUNT TRAY	
8	STC-1607	SP MOUNT BRKT	
9	STC-1608	SPEAKER NET L	
10	STC-1609	SPEAKER NET R	
11	STC-1610	SAFETY GUARD	
12	STC-1611	CABLE BEAR BRKT	
13	STC-1612	PROTECT RUBBER	
14	STC-1613	SAFETY GUARD F	
15	INY-1302-B	MASK CUSHION SIDE	
16	SPG-2404	SEAT FRAME BRKT	
101	601-9059	SEAT RAIL L	
102	601-9060	SEAT RAIL R	
103	130-5159	GULL BOX SPEAKER 8OHM 5W	
104	280-5009-01	CORD CLAMP 21	
105	601-6563-188	BUSH 2.4T	
106	601-6563-100	BUSH 2.4T	
107	280-5297	SCRIVET 8 1K31	
108	280-5275-SR10	CORD CLAMP SR10	
201	000-P00410-W	M SCR PH W/FS M4×10	
202	030-000850-S	HEX BLT W/S M8×50	
203	030-000816-S	HEX BLT W/S M8×16	
204	000-T00408-0B	M SCR TH BLK M4×8	
205	050-H00800	HEX NUT M8	
206	060-S00800	SPR WSHR M8	
207	068-852216	FLT WSHR 8.5-22×1.6	
208	012-P00412	TAP SCR #2 PH 4×12	
209	060-F00400	FLT WSHR M4	
210	000-T00616-0B	M SCR TH BLK M6×16	
211	010-P00408-F	S-TITE SCR PH W/F M4×8	
301	600-6774-016	WIRE HARN SPEAKER EXT	
302	600-6774-017	WIRE HARN SEAT EXT	

27 ASSY MAIN BASE 1P (SPG-20001)

(D-1/2)

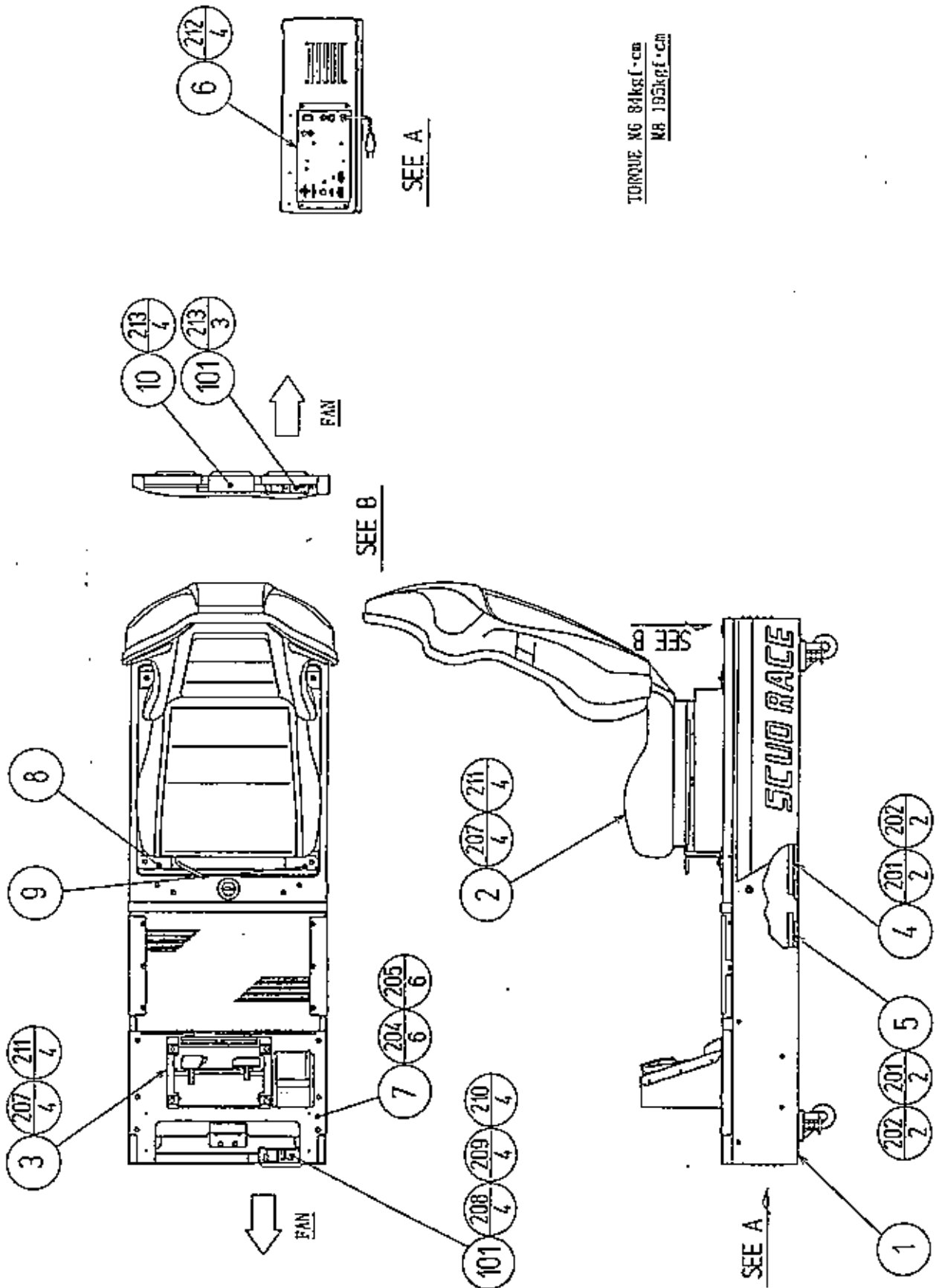

②7 ASSY MAIN BASE 1P (SPG-20001)

(D-2/2)

ITEM NO.	PART NO.	DESCRIPTION	NOTE
1	SPG-1500	ASSY BASE BOX	
2	SPG-1600	ASSY SEAT TWIN 1P	
3	SPG-2200	ASSY ACCEL&BRAKE	
4	SPG-4400	ASSY MAIN BD BASE	
5	SPG-4500	ASSY ELEC BASE	
6	SPG-0400	AC UNIT MAIN	AC 110V 60HZ ARBA
	SPG-0400-01	AC UNIT MAIN EXP	AC 220V 50HZ ARBA
	SPG-0400-02	AC UNIT MAIN KOREA	AC 220V 60HZ ARBA
	SPG-0400-03	AC UNIT MAIN AUS	AUSTRALIA
7	SPG-1502	PEDAL BASE	
8	RAL-2007	RUBBER HOLDER R TWIN	
9	RAL-2008	RUBBER HOLDER L TWIN	
10	SPG-1503	FAN BRKT	
101	260-0011-02	AXIAL FLOW FAN AC100V 50-60HZ	
102	600-6275-0150	ASSY FIBER CABLE 5 0150CM	
103	601-0460	PLASTIC TIE BELT 100 M/M	
104	280-5009-01	CORD CLAMP 21	
105	280-5275-SR10	CORD CLAMP SR10	
106	280-5169	CORD CLAMP TL-20S	
201	000-P00425-W	M SCR PH W/FS M4×25	
202	068-441616	FLT WSHR 4.4-16×1.6	
203	050-F00500	FLG NUT M5	
204	030-000616-SB	HEX BLT W/S BLK M6×16	
205	060-F00600-0B	FLT WSHR BLK M6	
207	060-F00800-0B	FLT WSHR BLK M8	
208	000-P00350	M SCR PH M3×50	
209	060-S00300	SPR WSHR M3	
210	060-F00300	FLT WSHR M3	
211	030-000825-SB	HEX BLT W/S BLK M8×25	
212	000-P00408-WB	M SCR PH W/FS BLK M4×8	
213	000-P00312-W	M SCR PH W/FS M3×12	
301	600-6873-81	WIRE HARN EARTH REAR	
302	600-6873-032	WIRE HARN FRONT FAN	
303	600-6873-033	WIRE HARN REAR FAN	
304	600-6873-035	WIRE HARN EXT RGB	
305	600-6873-037	WIRE HARN EXT CONT PNL A	
306	600-6873-048	WIRE HARN EXT VOLUME A	
307	600-6873-051	WIRE HARN EXT REAR SPEAKER	
308	600-6873-053	WIRE HARN EXT TOWER	

②8 ASSY MAIN BASE 2P (SPG-21001)

(D-1/2)

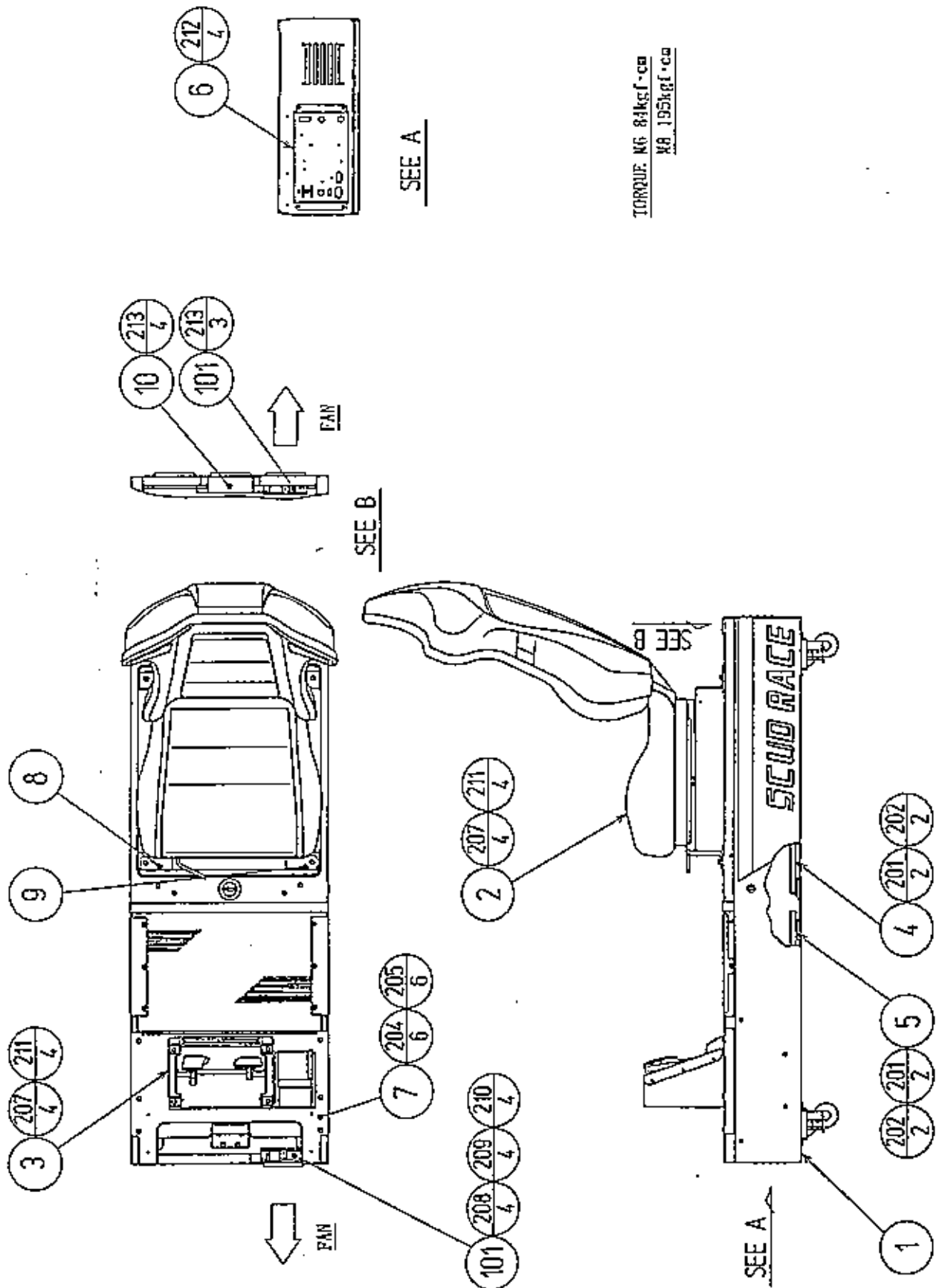

TORQUE: NG 84kgf·cm
 NA 195kgf·cm

②8 ASSY MAIN BASE 2P (SPG-21001)

(D-2/2)

ITEM NO.	PART NO.	DESCRIPTION	NOTE
1	SPG-1500	ASSY BASE BOX	
2	SPG-1700	ASSY SEAT TWIN 2P	
3	SPG-2200	ASSY ACCEL&BRAKE	
4	SPG-4400	ASSY MAIN BD BASE	
5	SPG-4500	ASSY ELEC BASE	
6	SPG-0700	AC UNIT SUB	
7	SPG-1502	PEDAL BASE	
8	RAL-2007	RUBBER HOLDER R TWIN	
9	RAL-2008	RUBBER HOLDER L TWIN	
10	SPG-1503	FAN BRKT	
101	260-0011-02	AXIAL FLOW FAN AC100V 50-60HZ	
102	600-6275-0150	ASSY FIBER CABLE 5 0150CM	
103	601-0460	PLASTIC TIE BBLT 100 M/M	
104	280-5009-01	CORD CLAMP 21	
105	280-5275-SR10	CORD CLAMP SR10	
106	280-5169	CORD CLAMP TL-20S	
201	000-P00425-W	M SCR PH W/FS M4×25	
202	068-441616	FLT WSHR 4.4-16×1.6	
203	050-F00500	FLG NUT M5	
204	030-000616-SB	HEX BLT W/S BLK M6×16	
205	060-F00600-0B	FLT WSHR BLK M6	
207	060-F00800-0B	FLT WSHR BLK M8	
208	000-P00350	M SCR PH M3×50	
209	060-S00300	SPR WSHR M3	
210	060-F00300	FLT WSHR M3	
211	030-000825-SB	HEX BLT W/S BLK M8×25	
212	000-P00408-WB	M SCR PH W/FS BLK M4×8	
213	000-P00312-W	M SCR PH W/FS M3×12	
301	600-6873-81	WIRE HARN EARTH REAR	
302	600-6873-032	WIRE HARN FRONT FAN	
303	600-6873-033	WIRE HARN REAR FAN	
304	600-6873-035	WIRE HARN EXT RGB	
305	600-6873-037	WIRE HARN EXT CONT PNL A	
306	600-6873-048	WIRE HARN EXT VOLUME A	
307	600-6873-051	WIRE HARN EXT REAR SPEAKER	
308	600-6873-053	WIRE HARN EXT TOWER	

29 ASSY ACCEL & BRAKE (SPG-2200)

(D-1/2)

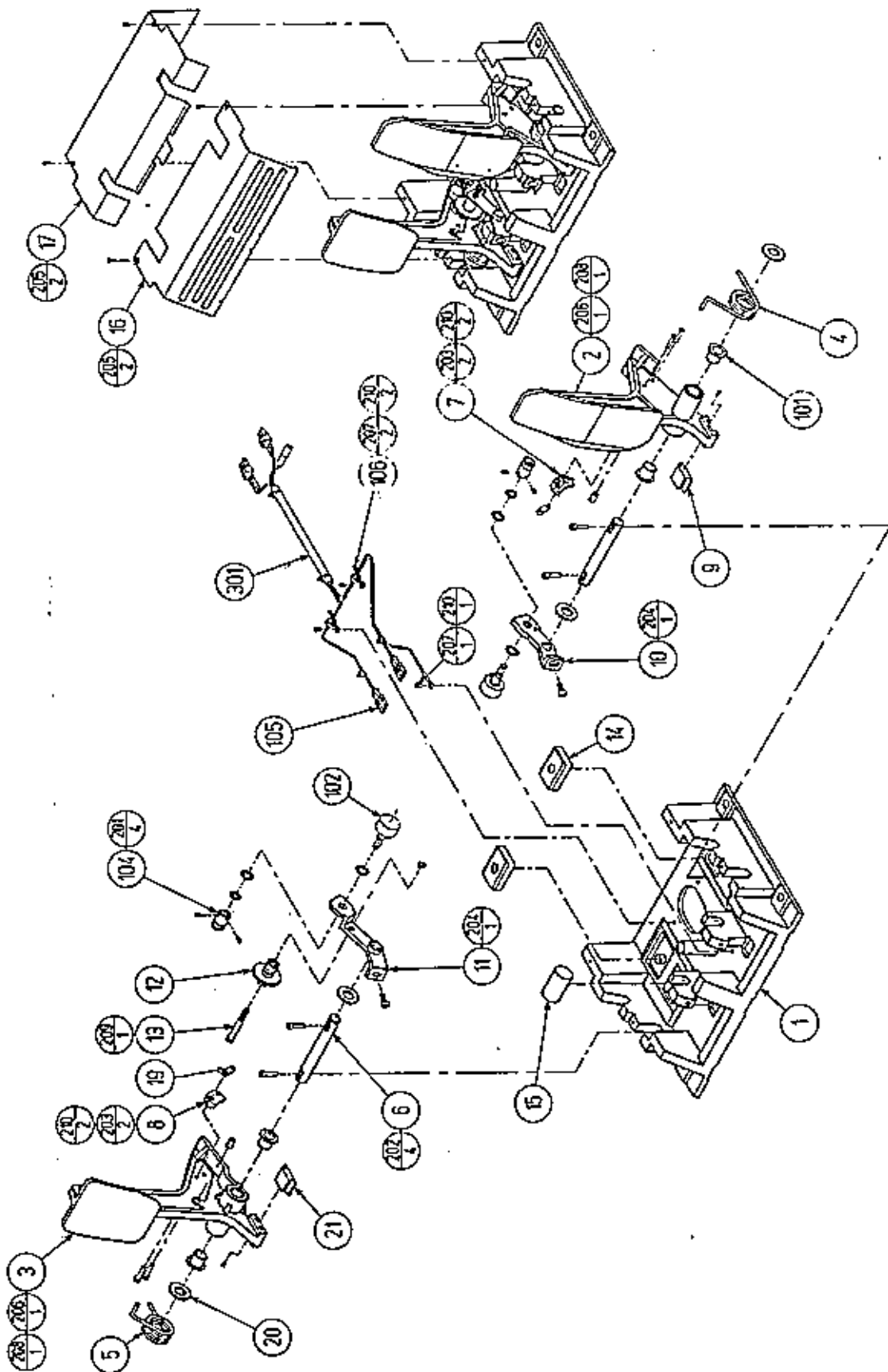

②9 ASSY ACCEL & BRAKE (SPG-2200)

(D-2/2)

ITEM NO.	PART NO.	DESCRIPTION	NOTE
1	SPG-2201	BASE	
2	SPG-2202	ACCEL PEDAL	
3	SPG-2203	BRAKE PEDAL	
4	SPG-2204	ACCEL SPRING	
5	SPG-2205	BRAKE SPRING	
6	SPG-2206	SHAFT	
7	SPG-2207	ACCEL GEAR	
8	SPG-2208	BRAKE GEAR	
9	SPG-2209	NEUTRAL STOPPER	
10	SPG-2210	VR PLATE ACCEL	
11	SPG-2211	VR PLATE BRAKE	
12	SPG-2212	AMPL GEAR	
13	SPG-2213	GEAR SHAFT	
14	SPG-2214	STOPPER	
15	SPG-2215	RUBBER CUSHION	
16	SPG-2216	COVER	
17	SPG-2217	VR COVER	
19	SPG-2219	GEAR STAY	
20	SPG-2220	WSHR	
21	SPG-2221	NEUTRAL STOPPER D	
101	100-5263	BEARING 12	
102	220-5484	VOL CONT B-5K OHM	
104	601-7944	GEAR 15	
105	310-5029-F15	SUMITUBE F F15MM	
106	280-0419	HARNES LUG	
201	028-A00304-P	SET SCR HEX SKT CUP P M3×4	
202	020-000520-OZ	HEX SKT H CAP SCR BLK OZ M5×20	
203	000-P00420	M SCR PH M4×20	
204	000-P00512-W	M SCR PH W/FS M5×12	
205	000-T00408-OC	M SCR TH CRM M4×8	
206	FAS-450005	SPR PIN BLK OZ 6×10	
207	000-P00405	M SCR PH M4×5	
208	FAS-000001	M SCR TH CRM M3×6	
209	050-H00500	HEX NUT M5	
210	060-F00400	FLT WSHR M4	
301	600-6840	WIRE HARN ACCEL & BRAKE	

30 ASSY MAIN BD BASE (SPG-4400)

(D-1/2)

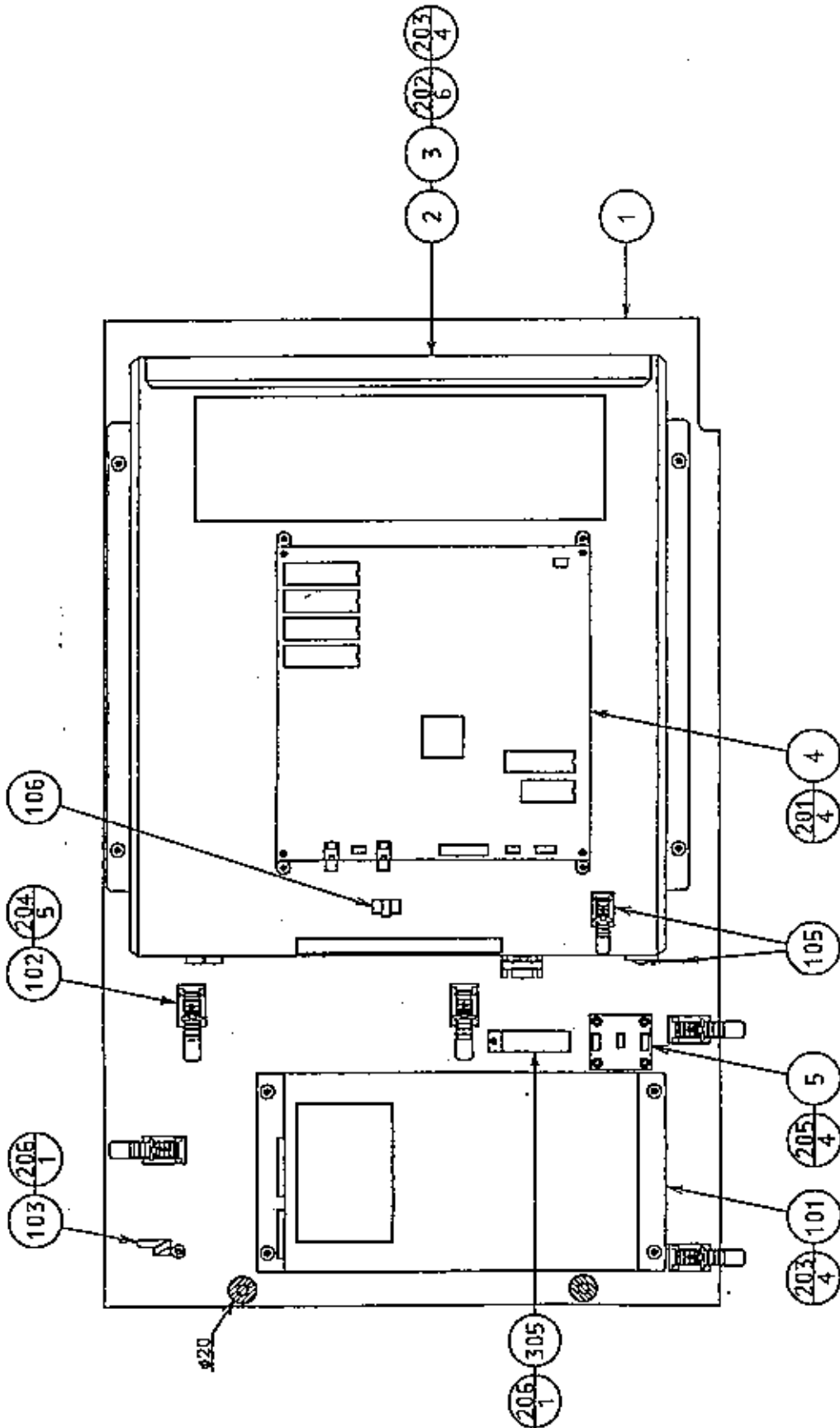

Make sure that there is no wiring, etc. in the slash mark portions.

③ ASSY MAIN BD BASE (SPG-4400)

(D-2/2)

ITEM NO.	PART NO.	DESCRIPTION	NOTE
1	SPG-4401	WOODEN BASE	
2	SPG-4600	ASSY SHIELD CASE	OTHERS
	SPG-4600-01	ASSY SHIELD CASE AUS	AUSTRALIA
3	105-5241	SHIELD CASE BRKT	
4	837-12941	SOUND BD SPG DX	
5	839-0542	AUDIO MIX BD	
101	400-5330-01	SW REGU FOR MODEL3	
102	280-5009-01	CORD CLAMP 21	
103	280-0419	HARNESS LUG	
104	601-0460	PLASTIC TIE BELT 100 M/M	
105	280-5008	CORD CLAMP 15	
106	280-5275-SR10	CORD CLAMP SR10	
201	000-F00308	M SCR FH 3×8	
202	000-P00408-W	M SCR PH W/PS M4×8	
203	000-P00412-W	M SCR PH W/PS M4×12	
204	011-F00310	TAP SCR FH 3×10	
205	011-T00325	TAP SCR TH 3×25	
206	011-T03512	TAP SCR TH 3.5×12	
301	600-6873-017	WIRE HARN GAME BD DC IN	
302	600-6873-018	WIRE HARN MAIN BASE DC	
303	600-6873-019	WIRE HARN GAME BD A/D & TX	
304	600-6873-020	WIRE HARN GAME BD	
305	600-6873-021	WIRE HARN GAME BD RGB	
306	600-6873-022	WIRE HARN SOUND 1	
307	600-6873-023	WIRE HARN SOUND 2	
308	600-6873-024	WIRE HARN MIDI	
309	600-6873-025	WIRE HARN SOUND BD TO MIX BD	

③1 ASSY ELEC BASE (SPG-4500)

(D-1/2)

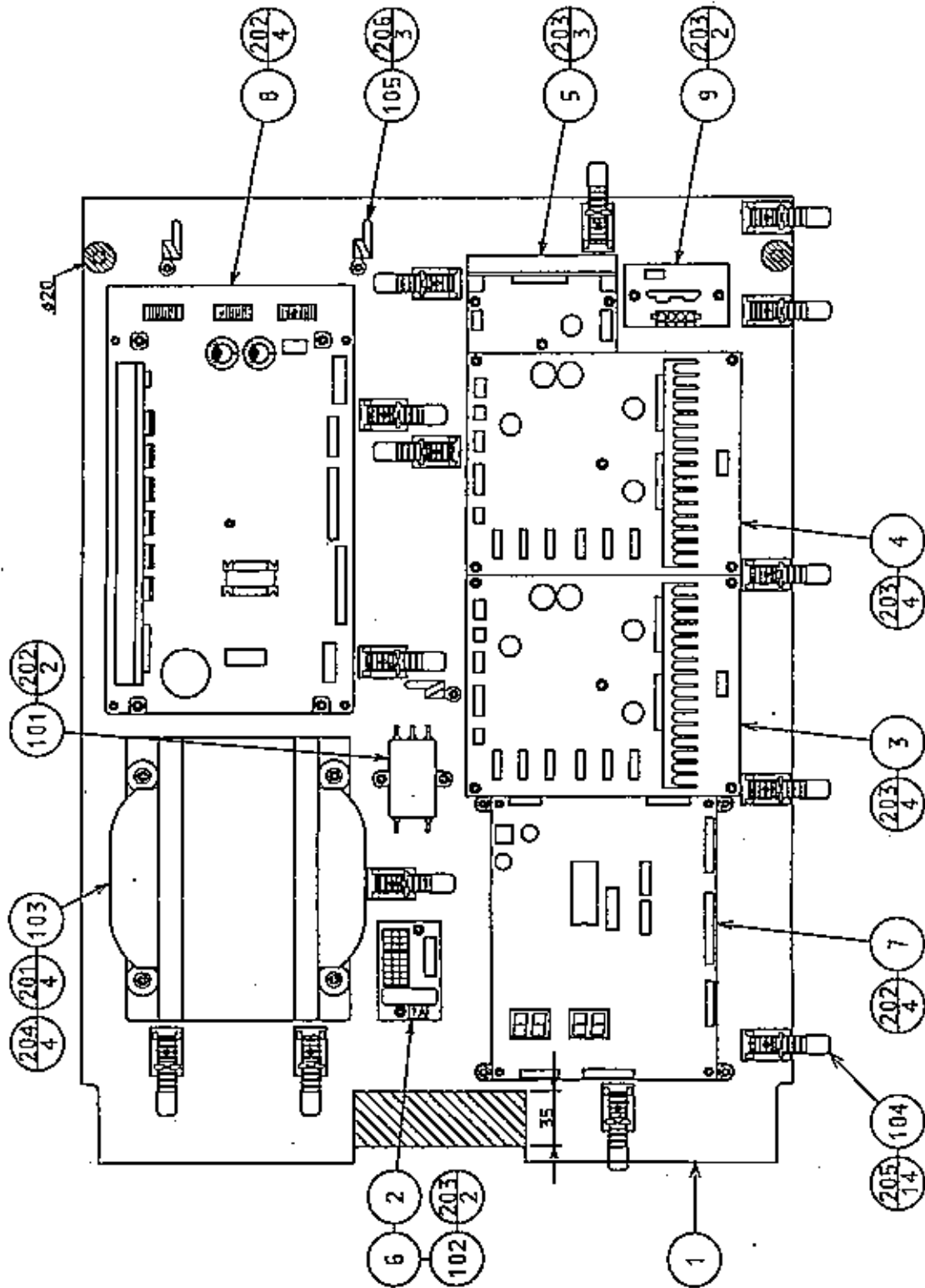

(31) ASSY ELEC BASE (SPG-4500)

(D-2/2)

ITEM NO.	PART NO.	DESCRIPTION	NOTE
1	SPG-4501	WOODEN BASE ELEC	
2	421-6395-11	STICKER 7A	
3	838-11650-22	EQ. PWR AMP SPG TWIN A	
4	838-11650-23	EQ. PWR AMP SPG TWIN B	
5	838-11651	LOWPASS AMP	
6	838-11856-01	CONNECT BD W/FUSE & COVER	
7	838-12898	DRIVE BD SPG DX	
8	838-12912	SERVO MOTOR DRIVE BD SPG	
9	839-0718-01	4A DC SSR BD CONN BROWN	
101	270-5020	NOISE FILTER AC250V 6A	
102	514-5036-7000	FUSE 6.4x30 7000MA 125V	
103	560-5359	PWR XFMR 100V6.5A 12.5V6Ax2	
104	280-5009-01	CORD CLAMP 21	
105	280-0419	HARNES LUG	
106	601-0460	PLASTIC TIE BELT 100 M/M	
201	000-P00416-S	M SCR PH W/S M4x16	
202	011-T00316	TAP SCR TH 3x16	
203	011-T00325	TAP SCR TH 3x25	
204	068-441616	FLT WSHR 4.4-16x1.6	
205	011-F00310	TAP SCR FH 3x10	
206	011-T03512	TAP SCR TH 3.5x12	
301	600-6873-001	WIRE HARN XFMR IN	
302	600-6873-002	WIRE HARN XFMR 100V OUT	
303	600-6873-003	WIRE HARN CONN BD 9P	
304	600-6873-004	WIRE HARN CONN BD 15P	
305	600-6873-005	WIRE HARN N. FILTER TO DRIVE BD	
306	600-6873-006	WIRE HARN XFMR 12.5V OUT	
307	600-6873-007	WIRE HARN AMP AUDIO IN	
308	600-6873-008	WIRE HARN ELEC REAR SPEAKER	
309	600-6873-009	WIRE HARN AMP TO AMP	
310	600-6873-010	WIRE HARN ELEC FRONT SPEAKER	
311	600-6873-011	WIRE HARN ELEC DC IN	
312	600-6873-012	WIRE HARN TX & RX	
313	600-6873-013-91	WIRE HARN DRIVE BD	
314	600-6873-014	WIRE HARN SERVO DRIVE BD 10P	
315	600-6873-015	WIRE HARN ELEC MOTOR	
316	600-6873-016	WIRE HARN SSR BD IN	

③② ASSY SHIELD CASE (SPG-4600)

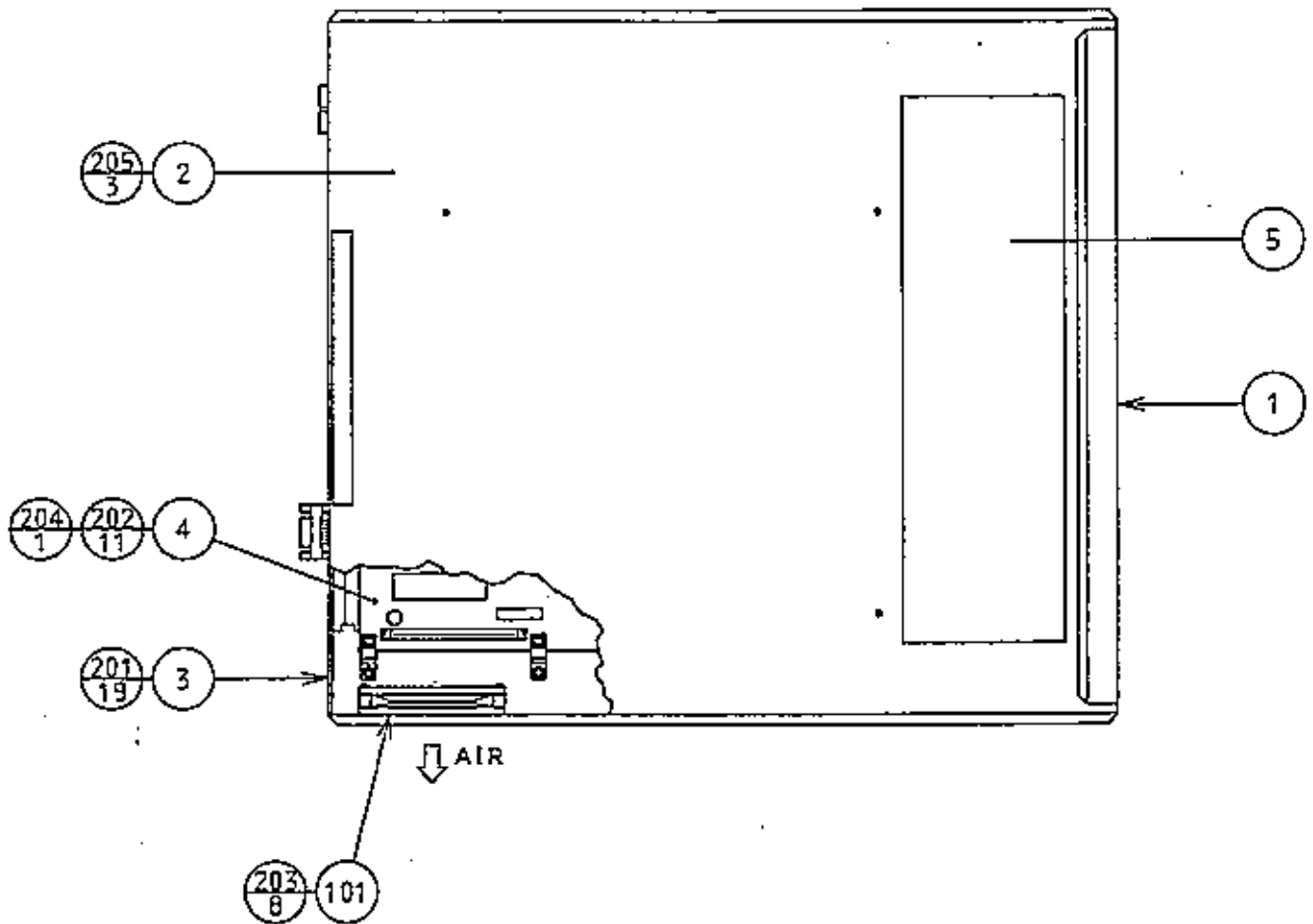

ITEM NO.	PART NO.	DESCRIPTION	NOTE
1	105-5245	SHIELD CASE MODEL3 NVS	
2	105-5242X	SHIELD CASE LID MODEL3	
3	839-0932	FILTER BD MODEL3 SPG	
4	833-13041	GAME BD SPG FOR COMMUNICATION	
5	421-9174-01	STICKER CAUTION ANTISTATIC	
6	421-6510-13041	STICKER 833-13041	
7	601-8928	CARTON BOX MODEL3	
101	260-0064	FAN MOTOR DC12V	
102	280-5275-SR10	CORD CLAMP SR10	
103	601-0460	PLASTIC TIE BELT 100 M/M	
201	010-P00308-F	S-TITE SCR PH W/F M3x8	
202	010-P00310-F	S-TITE SCR PH W/F M3x10	
203	000-P00320-W	M SCR PH W/FS M3x20	
204	010-P00365-F	S-TITE SCR PH W/F M3x65	
205	000-P00408-W	M SCR PH W/FS M4x8	
301	600-6770-018-91	WIRE HARN FAN MOTOR	

③② ASSY SHIELD CASE AUS (SPG-4600-01)

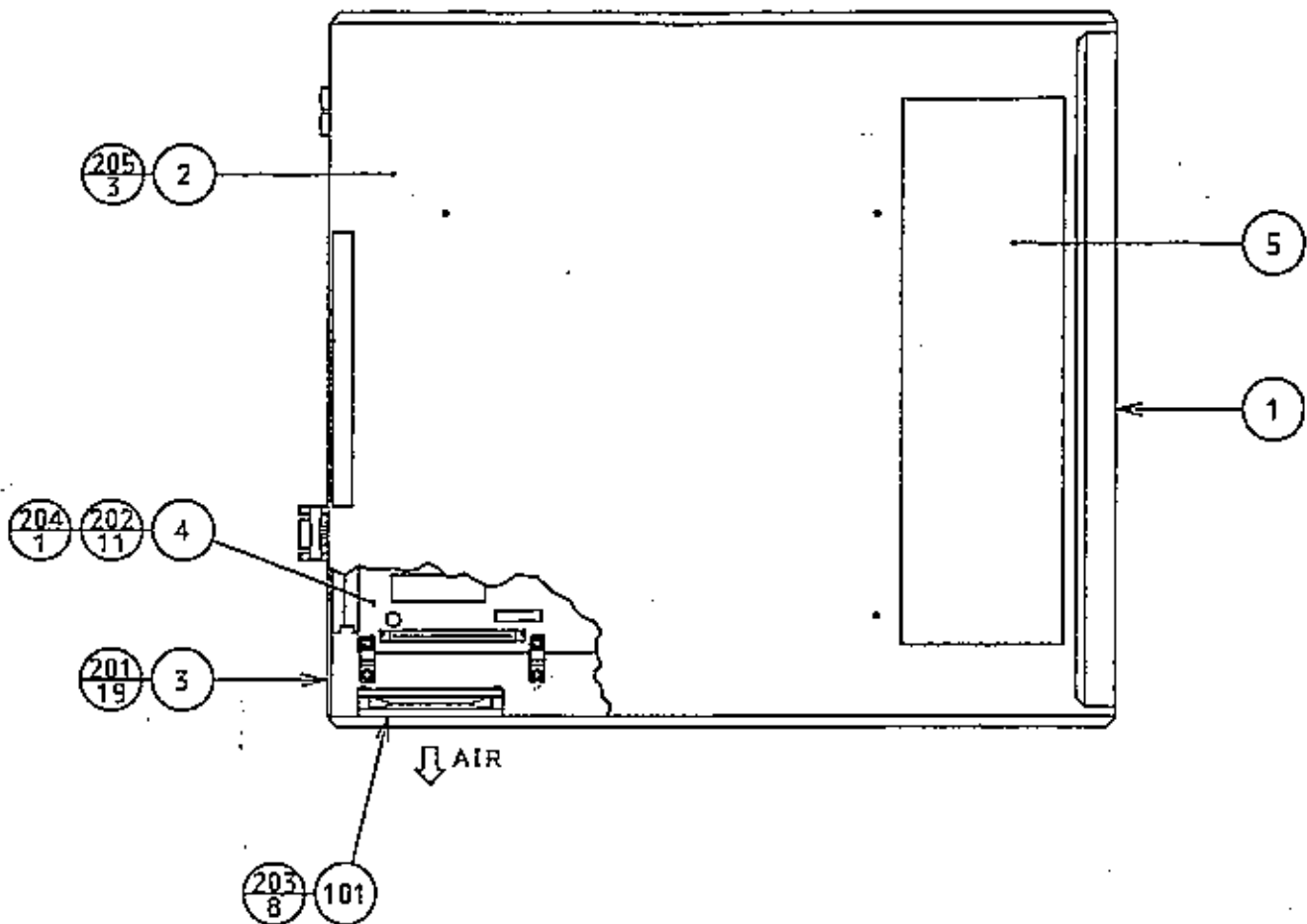

ITEM NO.	PART NO.	DESCRIPTION	NOTE
1	105-5245	SHIELD CASE MODEL3 NVS	
2	105-5242X	SHIELD CASE LID MODEL3	
3	839-0932	FILTER BD MODEL3 SPG	
4	833-13078	GAME BD SPG FOR COMM AUS	
5	421-9174-01	STICKER CAUTION ANTISTATIC	
6	421-6510-13078	STICKER 833-13078	
7	601-8928	CARTON BOX MODEL3	
101	260-0064	FAN MOTOR DC12V	
102	280-5275-SR10	CORD CLAMP SR10	
103	601-0460	PLASTIC TIE BELT 100 M/M	
201	010-P00308-F	S-TITE SCR PH W/F M3×8	
202	010-P00310-F	S-TITE SCR PH W/F M3×10	
203	000-P00320-W	M SCR PH W/FS M3×20	
204	010-P00365-F	S-TITE SCR PH W/F M3×65	
205	000-P00408-W	M SCR PH W/FS M4×8	
301	600-6770-018-91	WIRE HARN FAN MOTOR	

22. WIRE COLOR CODE TABLE

THE WIRE COLOR CODE is as follow:

A	PINK
B	SKY BLUE
C	BROWN
D	PURPLE
E	LIGHT GREEN

Wires other than those of any of the above 5 single colors will be displayed by 2 alphanumeric characters.

1	RED
2	BLUE
3	YELLOW
4	GREEN
5	WHITE
7	ORANGE
8	BLACK
9	GRAY

If the right-hand side numeral of the code is 0, then the wire will be of a single color shown by the left-hand side numeral (see the above).

Note 1: If the right-hand side alphanumeric is not 0, that particular wire has a spiral color code. The left-hand side character shows the base color and the right-hand side one, the spiral color.

<Example> 51 WHITE / RED

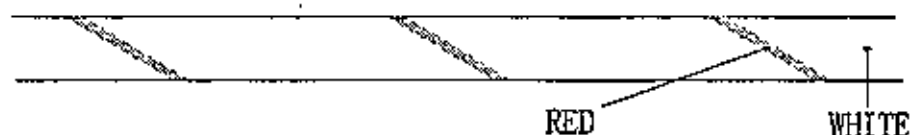

Note 2: The character following the wire color code indicates the size of the wire.

K:	AWG18, UL1015
L:	AWG20, UL1007
None:	AWG22, UL1007