



OWNER'S MANUAL

Ver.2.00



! WARNING

- For safety reasons, please read the manual first before plugging in machine.
- Please keep this manual properly for convenient reference as needed.

About This Manual

Thank you for purchasing this product.

The manual describes how to install, set up, use and maintain the product. The main purpose of the manual is to instruct how to operate the product correctly and safely. Please follow all the safety and warning instructions in the manual to avoid personal injury and product damage.

This product may only be maintained by a technician. A technician mainly refers to a person who has obtained a certificate of senior middle school related to mechanical engineering, electrical engineering or at a level equal to that of technical senior middle school graduates, and is engaged routinely in the maintenance, management, repair of amusement machine.

Please keep this manual properly for easy reference as needed. Moreover, if the operator entrust another party to operate, move, transport, install, maintain and repair the machine, please read relevant content and instruct concerned party to observe all the instructions and precautions in this manual regarding the particular action to be taken.

When transferring the ownership of this product, be sure to provide this manual with the machine.

For further information about the game and repair (including consumables), please contact our company.

© GuangZhou Wahlap Technology Limited All Rights Reserved.

Unauthorized reproduction of this document or any of its contents in any form is strictly forbidden.

Table of Contents

About This Manual

1. Safety Precautions	1
1.1 Warning Stickers	1
1.2 Placing Site	1
1.3 Safety Precautions	2
1.4 Precaution during Play	3
1.5 Transporting and Moving	3
1.6 Installing and Placing	4
1.7 Caution & Warning Stickers	5
2. Product Description	6
2.1 Product Specification	6
2.2 Overview	7
2.3 Spare Parts	8
2.4 Shipment List	9
2.5 Packing List	11
2.6 Install Direction	12
2.7 Warranty	13
3. Game Description	14
3.1 Appearance Design	14
3.2 Game Introduction	14
3.3 How to Play	14
3.4 Multiplayer Description	15
4. Test and Setting	16
4.1 Game Description	16
4.1.1 GAME FEATURE	16
4.1.2 GAME CONTENT	17
4.2 Game FLOW	20
4.2.1 Front-End MENU	20
4.2.2 In-Game MENU	27
4.2.3 Back-End MENU	31
4.3 Operator MENU	34
4.3.1 Arcade Operation Mode	34
4.3.2 Languages	35
4.3.3 Master Volume	35
4.3.4 Idle Volume	36
4.3.5 First Round Coins	36
4.3.6 Second Round Coins	37
4.3.7 Winner Bonus	37
4.3.8 Clock	38
4.3.9 Income	39
4.3.10 Record	39

4.3.11 Sound Testing	40
4.3.12 Light Testing	40
4.3.13 Button Testing	41
4.3.14 Calibration Steering (Auto)	42
4.3.15 Calibration Foot Pedal (Manual)	43
4.3.16 Video Split Number	44
4.3.17 Video ID	44
4.3.18 Patch	45
4.3.19 IO	45
4.3.20 Reset	46
4.3.21 Save	46
5. Maintenance and Service	47
5.1 Maintenance and Service	47
5.2 Part Replacement	48
5.2.1 Replacement of acrylic signboard	48
5.2.2 Replacement of fluorescent plate	48
5.2.3 Replacement of top light box	49
5.2.4 Key replacement	50
5.2.5 Replacement of pick-up head	50
5.2.6 Replacement of coin acceptor	51
6. Assembly	52
6.1 Assembly tree diagram	52
6.2 General assembly	53
6.2.1 Main wooden frame assembly	55
6.2.2 Main frame assembly	57
6.2.3 Motor assembly	58
6.2.4 Power box assembly	59
6.2.5 Transformer board assembly	60
6.2.6 Service board assembly	61
6.2.7 Speaker assembly	62
6.2.8 Right small light assembly	63
6.2.9 Left small light assembly	64
6.2.10 Plastic step box assembly	65
6.2.11 PCB board assembly	66
6.3 Seat assembly	67
6.3.1 Seat wooden crate assembly	68
6.3.2 Upper assembly of seat	69
6.3.3 Mainframe assembly	70
6.3.4 Backrest horn assembly	71
6.4 Plastic console assembly	72
6.4.1 Console keyboard assembly	73

6.5 LCD assembly	74
6.6 LCD glass assembly	75
6.7 Pick-up head assembly	76
6.8 Billboard Assembly	77
6.9 Right side light assembly	78
6.10 Left side light assembly	79
6.11 Push rod assembly	80
6.11.1 Handle assembly	81
6.11.2 Left side plate assembly	82
6.11.3 Right side plate assembly	83
6.11.4 Drive shaft assembly	84
6.11.5 Electromagnet assembly	85
6.11.6 Suction block assembly	86
6.12 Coin door assembly	87
6.13 Stepping cover assembly	88
6.14 Pedal assembly	89
6.15 Upper assembly of back door plate	90
6.16 Intermediate assembly of back door plate	91
6.17 Steeling wheel assembly	92
7. Printing Pattern	93
8. Wiring Diagram	96
9. After-Sales Service.	99

1. Safety Precautions

1.1 Warning Stickers

In order to avoid injury to related people and damage to property, please observe the followings:

PLEASE READ FIRST

- The following marks can be used to indicate the magnitudes of risk and damage caused by ignorance or improper operation:



means “may result in serious injury or death”



means “may result in minor injury or property damage”

Serious Injury: refers to the situations in which hospital treatment or long-term treatment will be accepted because of losing sight, getting hurt, getting burnt, electric shock, fracture or intoxication.

Minor Injury: refers to the cases that there is no need to go to hospital or accept long-term treatment.

Property Damage: refers to the damage of house, facility, or hurt of livestock and pet

1.2 Placing Site

Warning

- please make sure the place line has been grounded before product installation, setup, testing, operation or repair
- This machine is designed for indoor use only. Never install the machine outdoors. Meanwhile, please avoid the following locations indoor:
 - Direct sunlight, water leakage, damp and high temperature places.
 - Near Flammable, volatile, or/and dangerous substance.
 - Slope, unstable places or locations subject to frequent vibration.
 - Near emergency exit, fire extinguisher or similar equipment.
- The rear part has the vent for heat emission from PC or screen. Don't place anything nearby to avoid game failure.
- Provide a space of minimum 30cm between the rear of the machine and the wall for good ventilation and heat emission

1.3 Safety Precautions

The owner shall pay attention to the followings when placing, checking and repairing machine to insure player's security and avoid damage:

Warning

- please check the voltage is 110V or 220V before the machine connects to the power supply, or it may cause a fire or electric shock.
- Make sure to plug the game into 110V or 220V main outlet to avoid fire and electric shock.
- Make sure to turn off the power when performing maintenance and service to avoid electric shock or short circuit.
- Do not unplug or plug the plug instantly.
- Don't touch the power plug with a wet hand to avoid electric shock.
- Don't expose the power cord/grounding line on the passageway. Failure to do this will damage the power cord, causing electric shock or short circuit.
- Don't lay anything near the power cord to avoid fire.
- Do not pull the power cord when unplugging, please hold the plug to avoid power cord damage, causing fire or electric shock.
- In case of power cord damage, please contact the local distributor for replacement
- Only use fuse and spare parts specified by our company
- Connect the connector firmly and tighten the screws.
- Do not dismount, replace or convert the product without our permission in order to avoid damage and human injury due to improper operation.
- Check and maintain the machine regularly.
- Keep "Warning stickers" clean and legible. Replace it immediately when the words are not legible or the dirt can't be removed.
- Please contact our service center when performing any work that is not described in this manual, and follow the instruction provided.

1.4 Precautions during Play

Caution

- In order to avoid injury and accident during play, the following people shall not play the game:
 - People who are injured or less mobile.
 - Person with poor health condition, such as hypertension or heart disease.
 - Person wearing high-heeled or slippery shoes.
 - Person who can't touch the pedal.
 - Pregnant woman, drunk people.
- When a player feels uncomfortable during play, remind the person to have a break, or stop playing.
- Make sure the player reads the warning labels and other indications, and plays in accordance with the instructions to avoid accidents such as electric shock and short circuit.
- Bystander shall not operate any button when the player is playing the game to avoid unnecessary trouble.

1.5 Transporting and Moving

Caution

Transporting

- When transporting the machine with an elevator, be sure to employ "Lift Point" to prevent accident and damage to the machine.
- To prevent movement when transporting the machine on a vehicle, please fix the casters and fully retract the adjusters. Failure to do this may cause damage to the machine.
- When carrying the machine with a forklift, be sure to insert the fork to fork position and lift stably. If not, it may cause accident and damage to the machine.
- The glass and LCD screen are fragile. Avoid violent vibration or shock when transporting.

Moving

- Before moving the machine, unplug the power plug to prevent accident. Don't damage the cord.
- Pay attention to the obstructions and uneven surface when moving the machine to prevent accident and damage to the machine.
- Fully retract all adjusters before moving to prevent accident and hazard.
- Make sure to use at least two persons to conduct the above work to avoid accident and injury
- Pay attention to the moving direction, see fig.



1.6 Installing and Placing

Pay attention to the following when placing the machine.

Caution

- Place the machine on the flat and slip resistant area.
- Use the adjusters to fix the machine (See diagram 1)
 1. Loosen the nuts for the adjusters (clockwise), tighten the bolts with a wrench (clockwise).
 2. Tighten the nut firmly (counter clockwise) and fix it well.

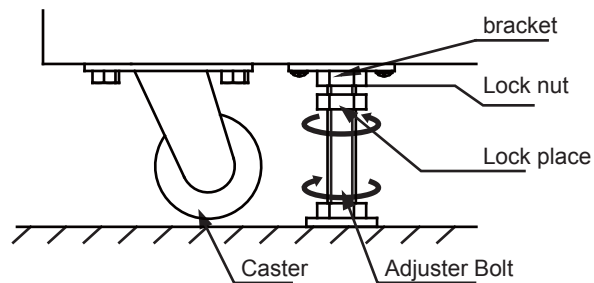

Diagram (1)

- Provide a space of minimum 30cm between the rear of the machine and the wall for good ventilation and heat emission (See diagram 2).

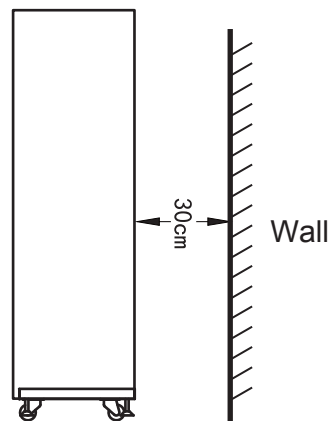
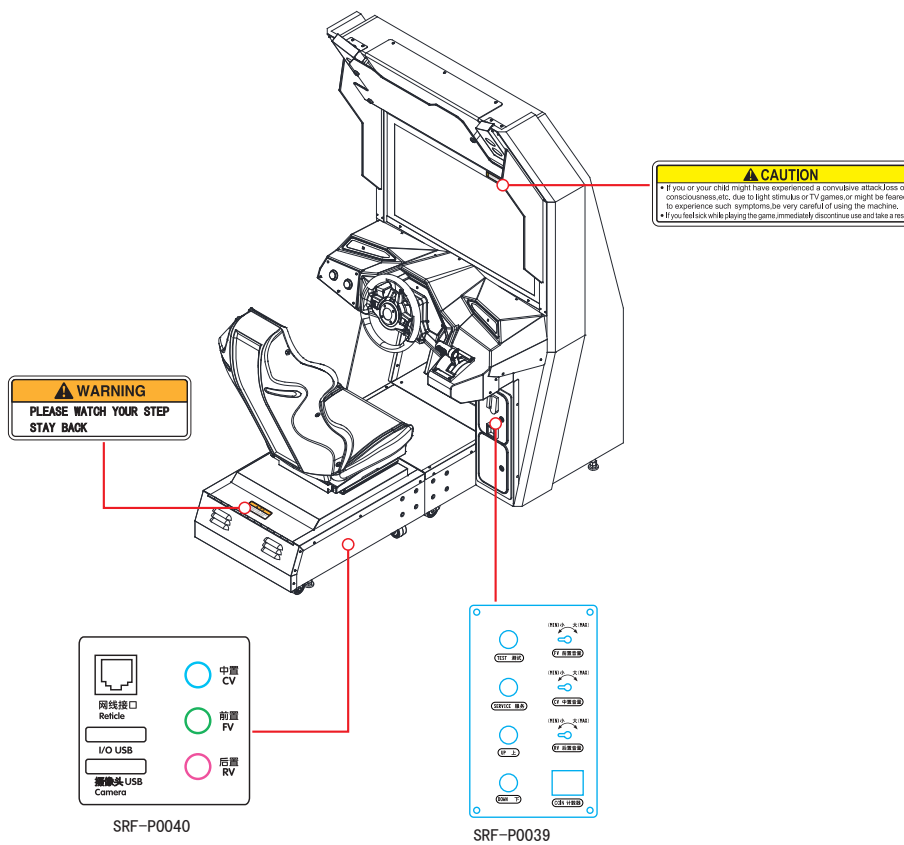
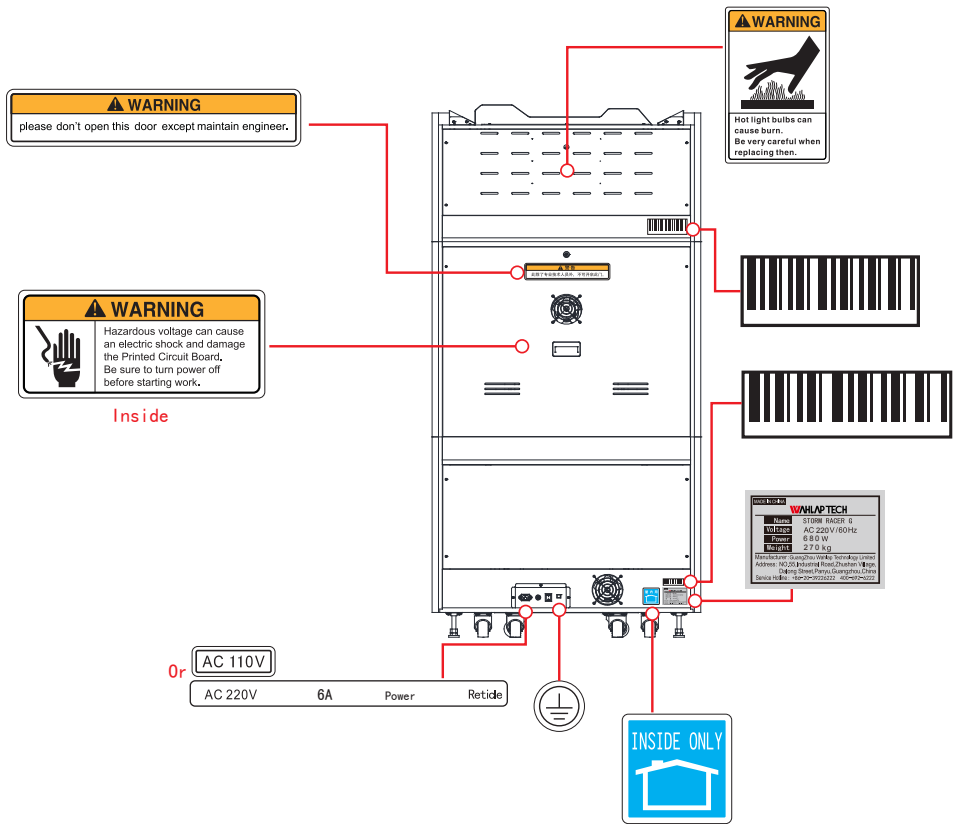

Diagram (2)

1.7 Caution & Warning Stickers



2. Product Description

2.1 Product Specification

■ Location	Indoor Only
■ Dimension	1050(W)×1730(D)×2075(H)
■ Rated Voltage	220V
■ Frequency	50Hz
■ Power Consumption	680W
■ Weight	270kg
■ Temperature Range	5~40 °C

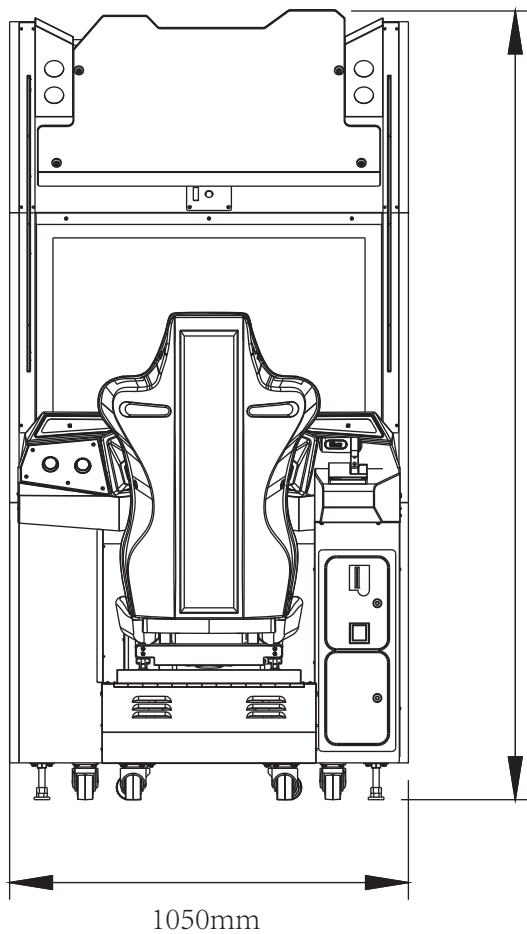

■ Front View

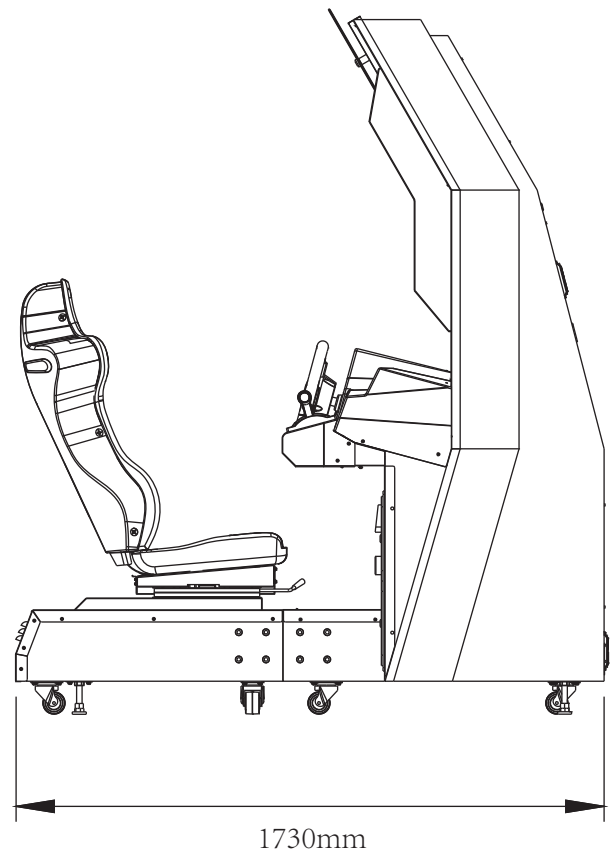

■ Side View

2.2 Overview

■ Side View

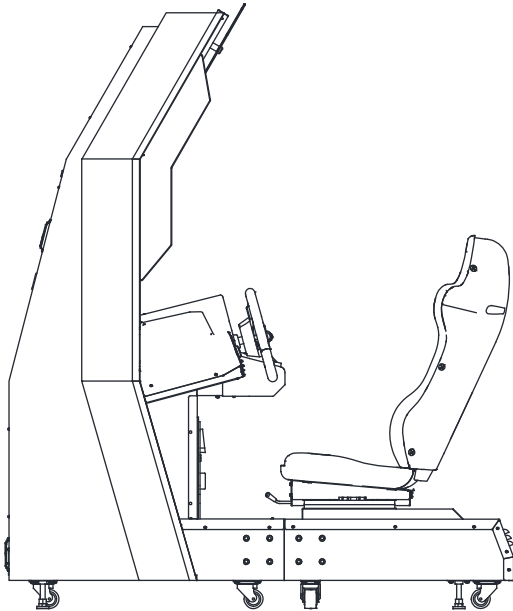

■ Rear View

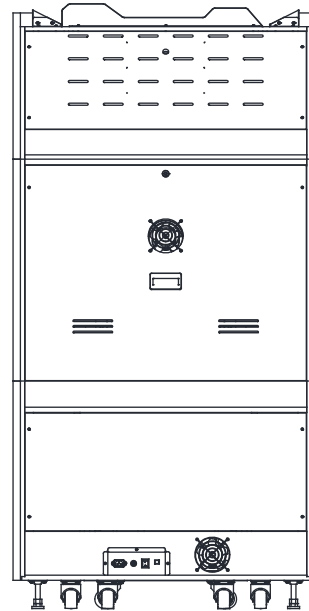

■ Top View

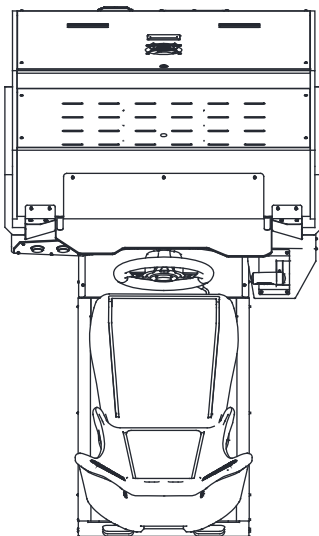

■ Bottom View

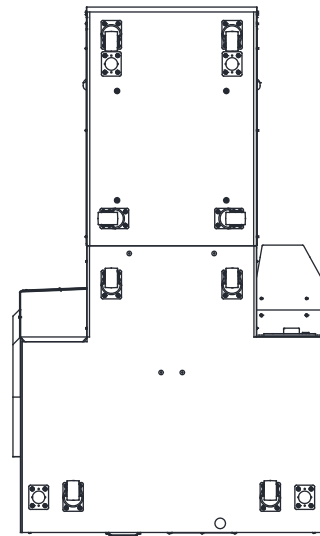

2.3 Spare Parts

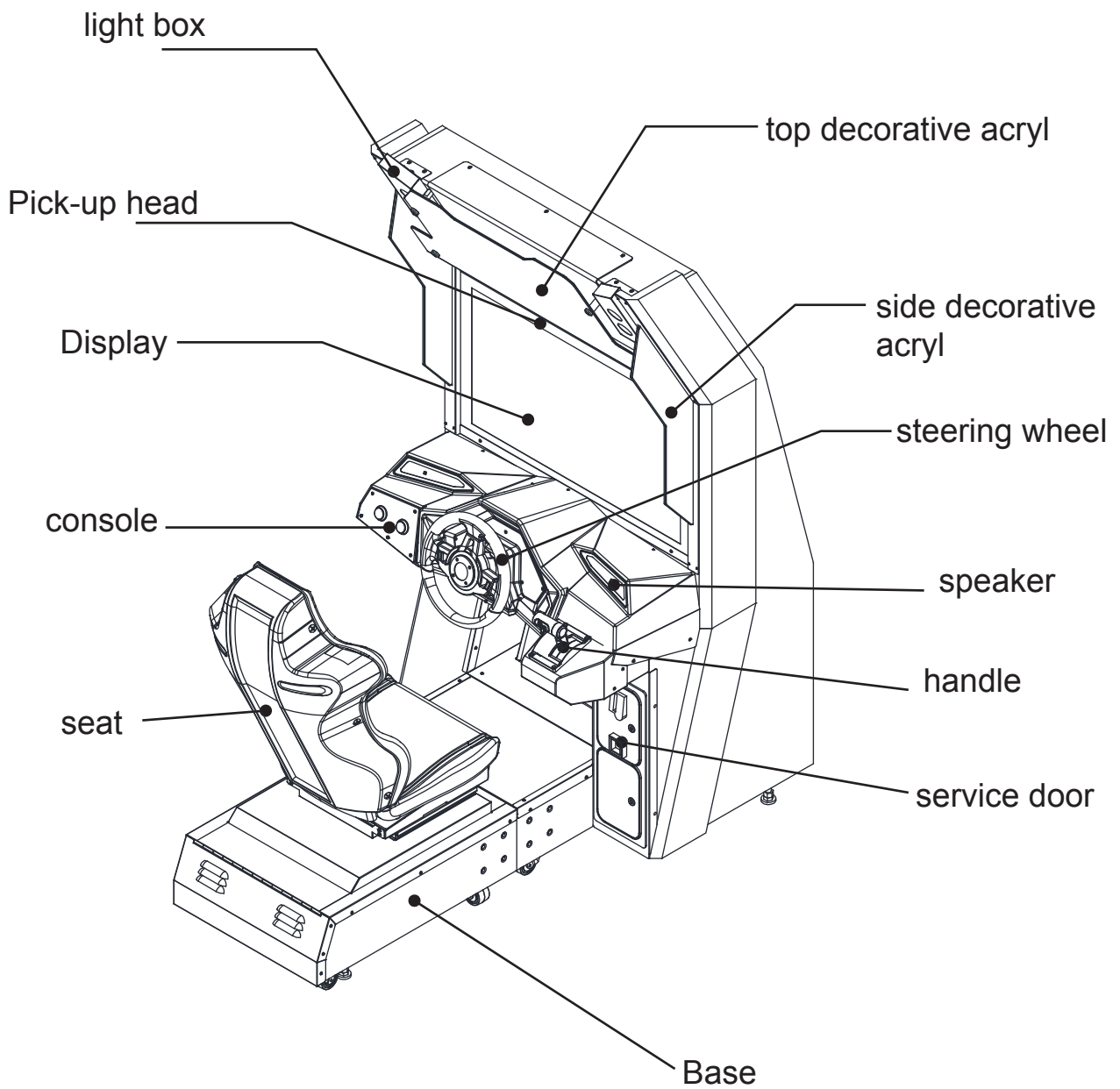

2.4 Shipment List

■ Packing Carton 1

Machine Name	STORM RACER G
Box Weight	270 kg
Box Size (W) (D) (H)	1147 x 1094 x 2240 mm
Note	Complete Unit
C/NO.	1/2

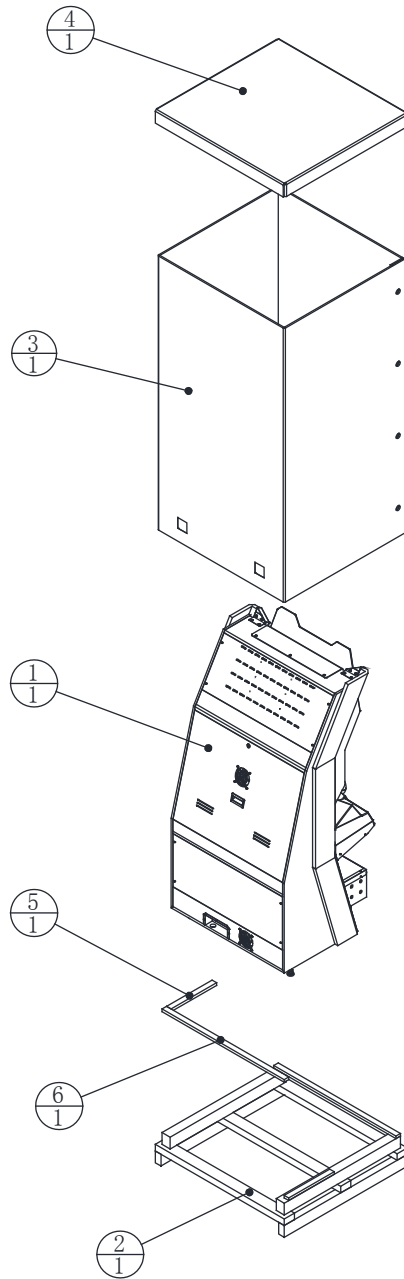

6	SRF-9901E05	框体限位木条02	实木 20*40*1077	1	
5	SRF-9901E04	框体限位木条01	实木 20*40*400	1	
4	SRF-9901E03	框体天盖	耐水3C1100G T-10	1	
3	SRF-9901E02	框体围框	耐水3C1100G T-10	1	
2	SRF-9901E01	框体地台		1	
1	SRF-0100000-A	主框体组件		1	
序号	图 号	名 称	材料/规格	数量	备注

■ Packing Carton 2

Machine Name	STORM RACER G		
Box Weight	85 kg		
Box Size	905	685	1490 mm
	(W)	(D)	(H)
Note	Chair, Accessory Carton		
C/NO.	2/2		

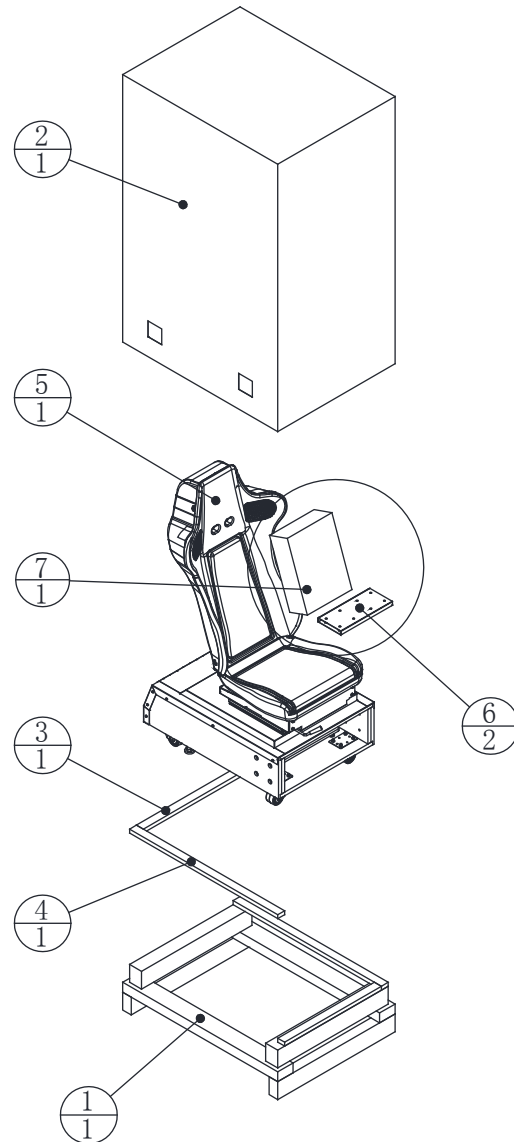

7		附属品箱	345*255*110mm	1	
6	SRF-0000A01	框体连接铁	SPCC-1.5T	2	
5	SRF-0200000	座位组件		1	
4	SRF-9902E04	座位限位木条02	实木 20*40*865	1	
3	SRF-9902E03	座位限位木条01	实木 20*40*565	1	
2	SRF-9902E02	座位无底半页箱	耐水3C1100G T-10	1	
1	SRF-9902E01	座位地台		1	
序号	图号	名称	材料/规格	数量	备注

2.5 Packing List

Please check the following items after purchasing our product. If any part missing or damaged, please contact our sales person!

Description	Specification	Quantity	Remarks
Powerline	3m (1.0m m ²) 250V	1	
Key	5555 key	2	
Flatgasket	Φ6*Φ20*2.0	16	
Spring gasket	M6	16	
Outer hexagon	M6*40	16	
Reticle	AMP gigabit 10M	1	
OWNER'S MANUAL		1	

2.6 Install Direction

■ Steps

- 1、 After opening the packing cartons 1 and 2, find the carton of accessories and outer hexagon M6*40 with flat spring washer shown as following figure.
- 2、 Assemble the machine by using the method shown in following figure.

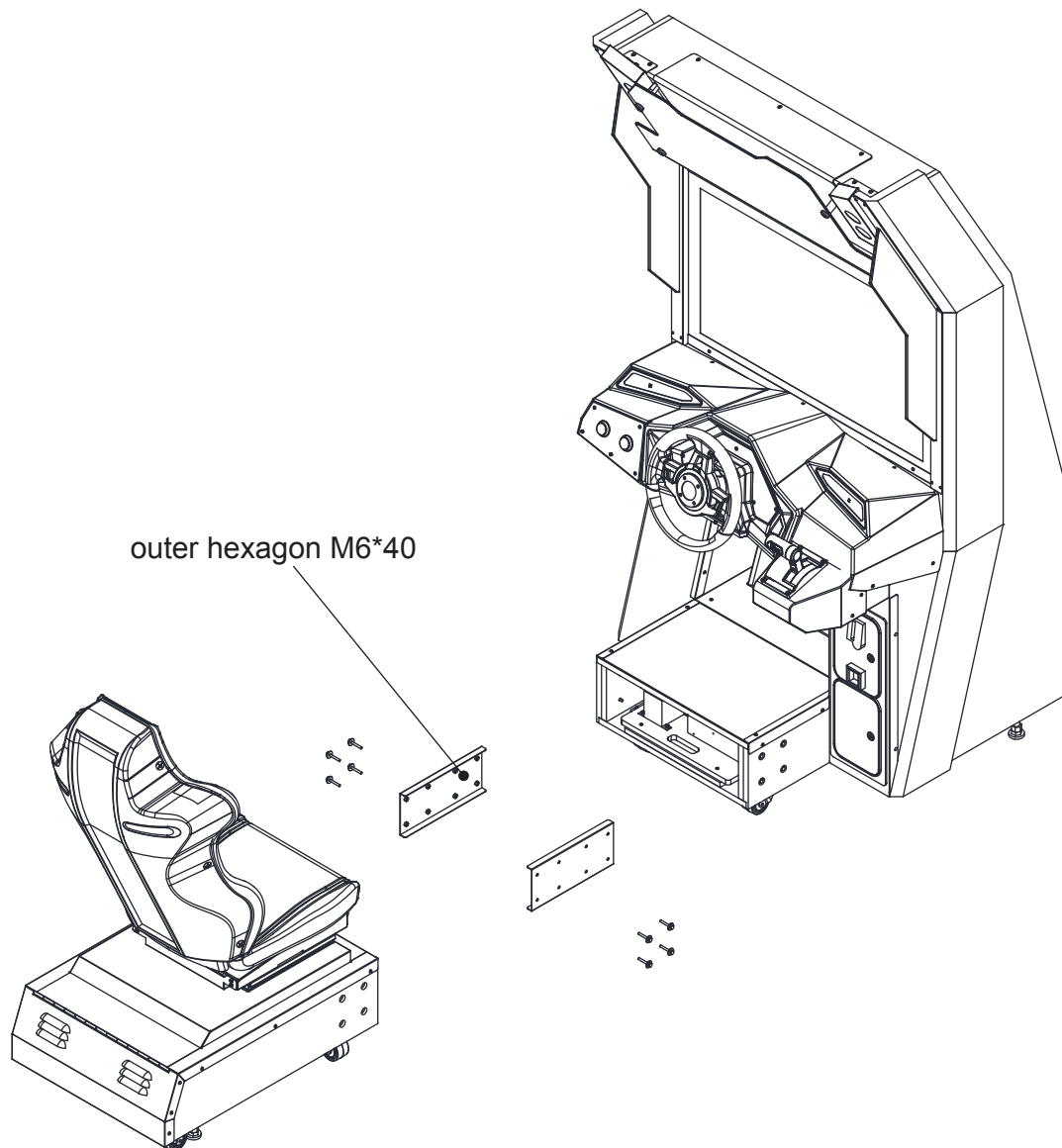

Special attention: when special case occurs in shipment, please check “Installation guide” in attachment box of shipment, and make assembly according to installation guide; special supplement will not be made in this instruction.

2.7 Warranty

■ Scope

- Inquiry regarding product can be assisted for free.
- The warranty scope for consumables and durables may differ from product to product. Please contact our after-sales service center for detailed information. The right of final interpretation is reserved.

■ Exclusive

- Damage caused by force majeure such as god will.
- Failure caused by carelessness, such as water contact, falling down, toppling, knocking.
- Failure caused by disobeying the instructions in this manual.
- Failure caused by operating the machine on inappropriate site.
- Change the original design and configuration for the game without notice.
- Failure to perform regular service and clean.
- Failure to fix the product in line with the manual's requirement.
- Malfunction or part damage caused by electromagnetic interference other electronic equipments generated.

■ Non-warranty Consumables

- Light tube and bulb
- Button lamp and switch
- Fragile items
- Solenoid
- Other spare parts

3. Game Description

3.1 Appearance Design

This machine has fashionable and beautiful appearance. The whole machine uses blue and black color tone and acrylic decoration permeable to light is used on its sides to let the blue light be visible when light is on, while the racing game is shown on the top decorative acrylic, without excessive decoration on the whole machine, so that the machine gives a stylish and elegant feeling. With respect to the operation, continue the usual mode of operation in racing game so that it is easier for the player to use and manipulate it.

3.2 Game introduction

Thunderous racing is a racing game, which uses 37inch LCD display, possesses 720DP HD screen with 60 frames per second; the whole game has six characteristic scenes, 12 race tracks, four difficulty levels of primary, intermediate, higher and extreme; support the multiplayer of at most 8 persons; in game, the sports car has strong individuality, with highly sensitive control performance and new thunderous acceleration system, so that different sports cars possess different operational advantages on different race tracks.

3.3 How to play

- 1、 Use the traditional mode of operation including steering wheel+pedal, at the same time, add the unique accelerator handle;
- 2、 The game rules: after coin, press START (START) key or step on the gas to enter into the screen of selecting the race track, turn the steering wheel for left and right selection, after the race track is determined, select the sports car by using the same method, after pressing START key, the game has begun and the sports car is ready, by stepping on the gas, you can play the game; the condition of accelerometer is shown on bottom right corner of screen, after certain thunderous value is collected, push the manual gear lever forward to enable the acceleration function of sports car.

3.4 Multiplayer Description

if the multiplayer game is played in the store, please refer to the following figure (take the connection of four machines as the example) and connect the network cables of mainframes of all machines to the jacks of broadband router. For broadband router,

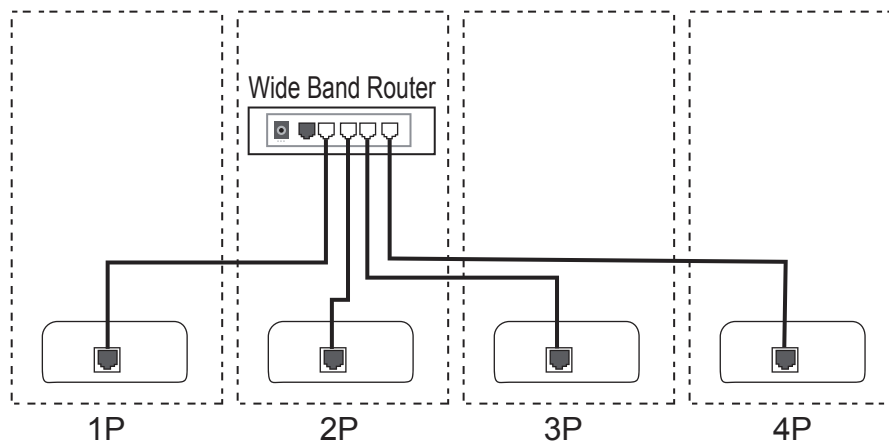

Remarks:

1. Please confirm the model of broadband .
2. This wiring diagram is only for reference and the actual connection method is possibly different due to network environment.

4. Test and Setting

4.1 Game Description

4.1.1 GAME FEATURE

- Up to 8 Players (LAN)
- HD 720p Resolution
- 30”inches screen
- 60 Frames per Second; High Sense of Speed with Fluent Game Play
- Online Patching /Upgrade Support
- Cloud-based Server
 - Advantage: Stable Internet Speed for All Regions
- Classic Arcade Racing Style
- Auto/Manual Drift Mode for Beginner/Expert
- Competitive AI
- Full Force Feedback Steering Wheel
- Unique Throttle for Boost
- 4.1 Sound System
- Vibration Speakers under the Seat simulate Car Response
- Intense Game Play Embedded with Camera Kit
- Compatible Low Maintenance Cost PC with Sandy Bridge Standard
- Total of 12 Tracks with 6 Hidden Tracks; Total of 14 Cars with 7 Hidden Cars

4.1.2 GAME CONTENT

Tracks

There are total of 12 tracks in 4 difficulties: Beginner, Advance, Expert and Extreme (appears in Reverse Tracks)..The game will begin with 6 Tracks –

- Circuits Of Rivers
- Ruin Temple
- The Heights
- Pearl City
- Stone Forest
- Snow Mountain

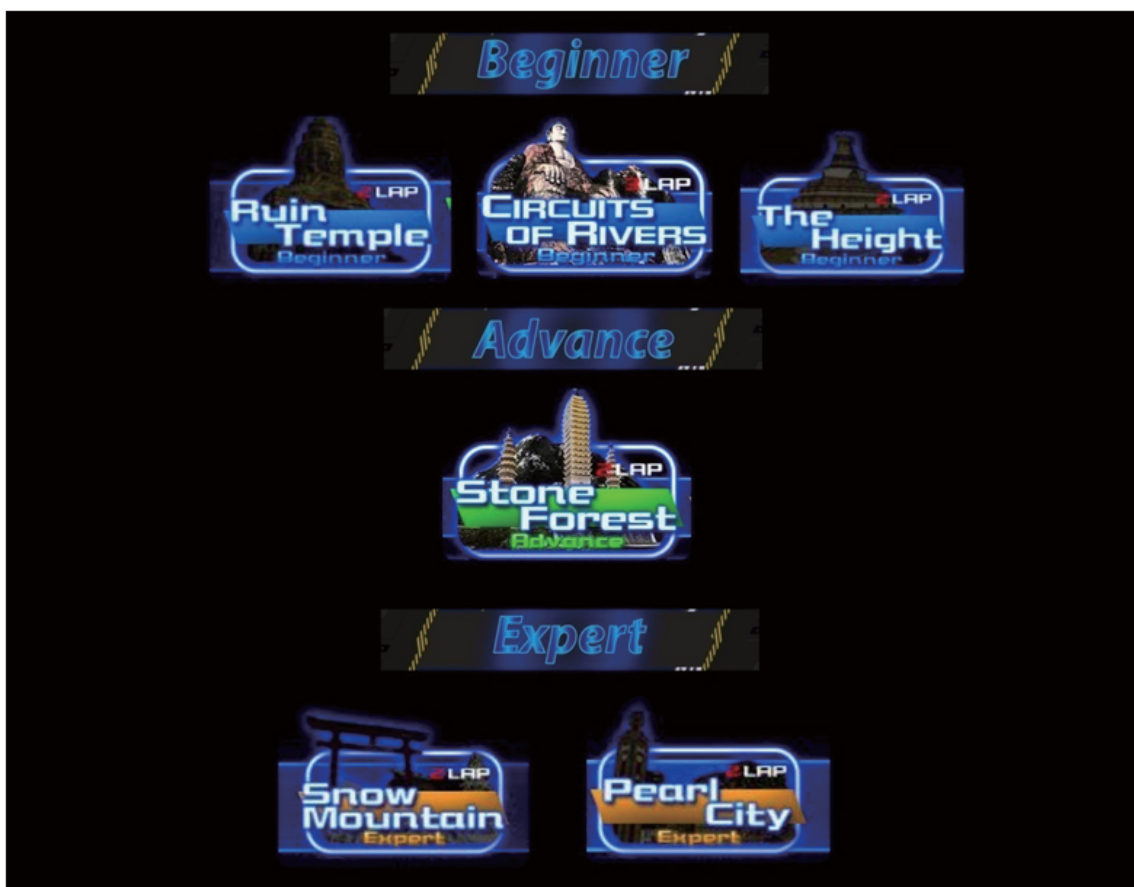

6 Hidden Tracks could be unlocked by counting how many G Coins the player has gained in every game.

How to Unlock Hidden Tracks?

An energy bar is shown to show the player how many G Coins he has gained in the last game and how many more he has to achieve in order to unlock certain hidden tracks.



Single-Play Mode:

- A new hidden track will be unlocked by counting how many G Coins the player has gained in every game.

Multi-Play Mode:

- A new hidden track will be unlocked by counting how many G Coins by all players have gained in every multi-play game.

For example: 4 players finished a game- track Circuits of River

Player	Player 1	Player 2	Player 3	Player 4	Total	Unlock Track
Position	1 st	2 nd	4 th	6 th	110	Circuits of River
G Coins gained	50	30	15	15		

Cars

There are a total of 14 cars. The game will begin with 7 Main Cars.
7 Hidden Cars could be unlocked by random.

7 Main Cars are in different levels: Beginner, Advance and Expert.



How to Unlock Hidden Cars? Single-Play Mode & Multi-Play Mode:

- A new hidden car will be unlocked in every game by random.
- 2 new hidden cars will be unlocked by The Champion in every game by random.



4.2 Game FLOW

4.2.1 Front-End MENU

Scene 1: Logo

Logo of Wahlap and Insoft will be appeared in the beginning.

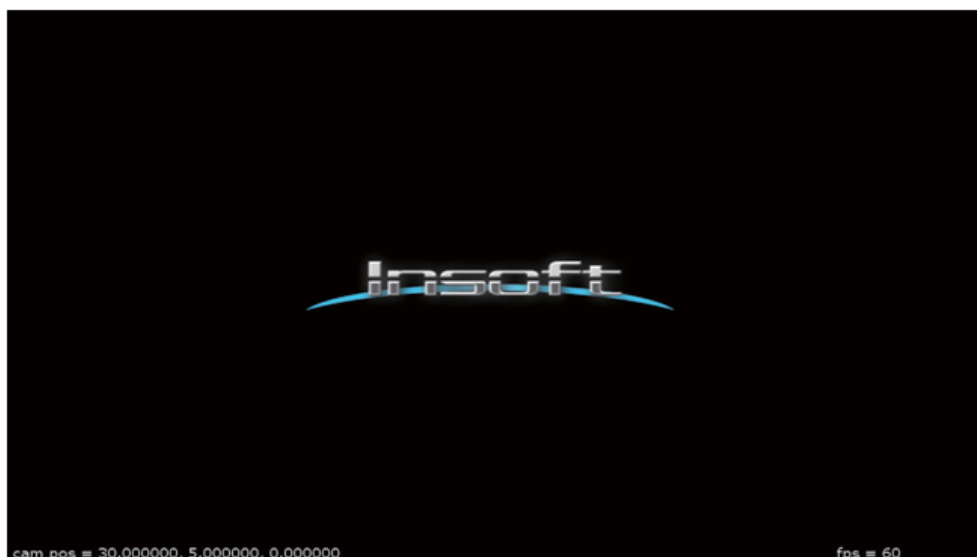

Scene 2: Intro Video (with learning video)

The Game Introduction video will be played. Learning videos will be appeared in between.

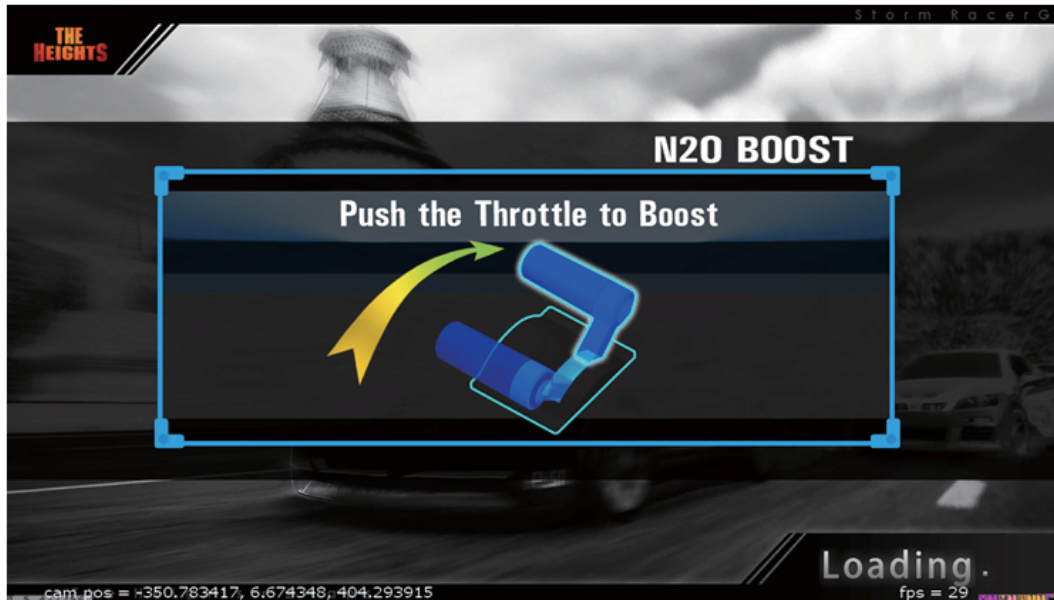

Scene 3: Insert Coins

A screen of insert coins will appear to ask player to start the game.



Scene 4: Selecting Track

In the Track Selection screen, there are a total of 12 tracks with 6 hidden tracks (to be unlocked). Tracks are divided into four difficulty levels: Beginner, Intermediate, Superior and Extreme, allowing players to challenge different difficulty levels.

Please use the steering wheel to turn left and right to select and then press the [START] button or step on the accelerator.



Scene 5: Selecting Car

In the Car Selection screen, there are a total of 14 cars with 7 hidden cars (to be unlocked). Cars are divided into three levels: Entry, Medium and Professional, drift and turn Bay deceleration is different at different levels.



Cars are presented in four different numerical rating to show their unique performance advantages:

- 1: Boost Gauge (that can influence the thunderous value, the value of thunderous acceleration forces)
- 2: Maximum Speed (The maximum speed in the general case)
- 3: Steering (there will be some advantage in a variety of Bay Road on the track)
- 4: Acceleration (speed of accelerate and overcome the rugged track)

Please use the steering wheel to turn left and right to select and then press the [START] button or step on the accelerator.

Scene 6: Camera

Players will be invited to take icon photos which will be displayed in the race. A photo is shot after a count down from 5 to 1.



Scene 7: “Free to Join” Multi-Players Race Status Screen

In a multi-player race, after selecting tracks and cars, a status screen will pop up to show the data of each player of this race (cars selected, own photo icons, level of players).

Players who are still selecting cars will be displayed as “Getting Ready” instead of his own data. The selected track will be displayed in the middle as well.



Scene 8: Loading Screen

Learning Messages will be shown as loading screen.

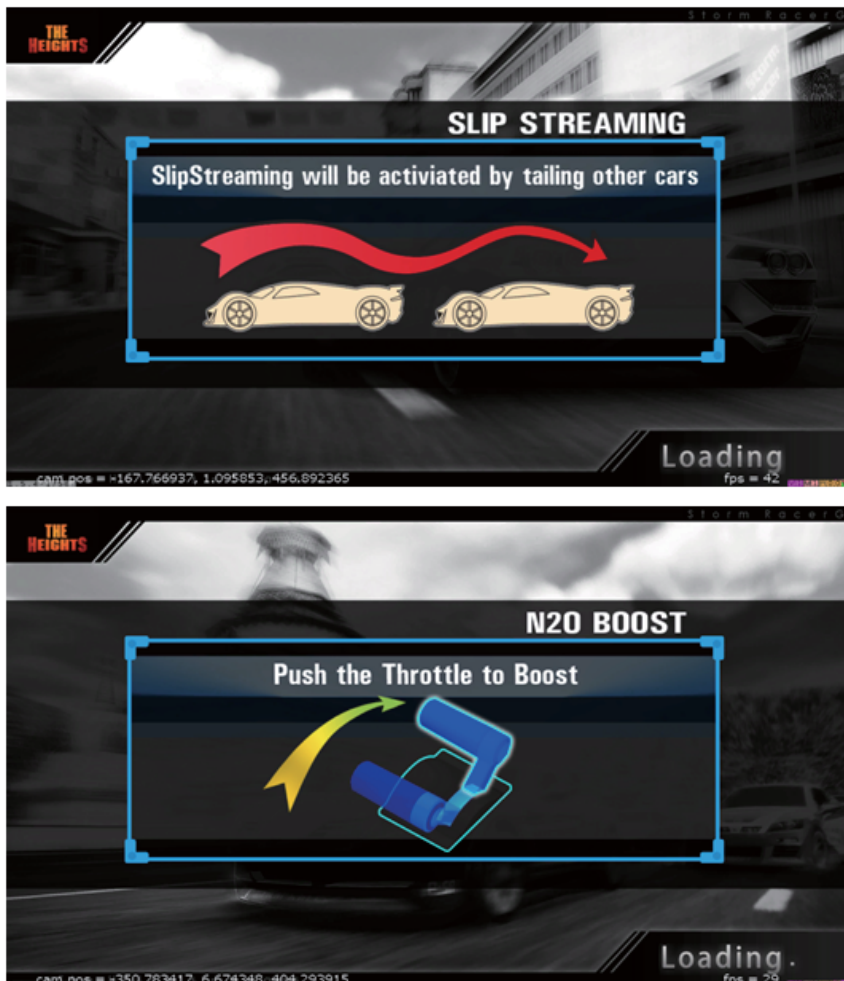

4.2.2 In-Game MENU

Scene 9: In-Game Screen

Game START

Race starts at once right after the loading is finished.



UI Screen (I)

When the Race begins, data of the Race will be displayed around four sides of the screen.



1. LAP: No. of Laps

2. TIME: Count Down (in seconds)

3. POSITION: Ranking of player

1-3 will change to RED in color in the last 60 seconds of the race.



4. Map: ▲ represents Player

● represents other Players

Multi-Play Mode – Free Join

In the first 30 seconds* of the battle, other players can join the race.



Race will start all over again if new player is joined. All players will select tracks and cars again.



Scene 10: FINISH Game

The race is over when time is up.
Position of the player will be shown.



4.2.3 Back-End MENU

Scene 11: Race Ranking

After the race is finished, a Final Ranking of all players will be shown.



1. Ranking of the tournament
 - Levels: S、A、B、C
 - S as the Supreme ranking; C as the lowest ranking
2. Tournament Data
 - a. Photo of player
 - b. Selected Car
 - c. Total Time
 - d. Medals obtained
3. Medals obtained

Scene 12: Unlocked Item

A page of unlocked items will be shown.

Players can show if any cars or tracks have been unlocked successfully in the race they just finished.

New track is unlocked:



New car is unlocked:



Scene 13: Continue

-For Winner: Bonus Round (Discount Game)

Winner of the tournament will be awarded to continue the game with discount.



-For Other Players: Game Over, Continue to Play

Players will be invited to continue the race to challenge and become the Winner.



4.3 Operator MENU

4.3.1 Arcade Operation Mode

1. Under the Demo screen, press the [Test] key of the coin control box to enter the [Arcade Operator], the main menu is shown below.



2. Enter the menu screen, use the arrow keys to select a menu item, press the [Test] key to enter the sub-menu, follow the screen prompt message at the bottom-right side.
3. After the setup is completed, select [Save] in the main menu, then press the [START] button or press the [services] to exit the user interface.



4.3.2 Languages

You can select the operating language in [Language].

1. Enter the [Arcade Operator] > [Language], use the left and right arrow keys to switch to the desired language.



4.3.3 Master Volume

In [Master Volume], you can set the outputs of the volume of sounds by the arcade machine.

1. Enter the [Arcade Operator] > [Master Volume], the inputs of the volume are set between 0-1.



4.3.4 Idle Volume

In [Idle Volume], you can set the outputs of the volume of sounds by the arcade machine.

1. Enter the [Arcade Operator] > [Idle Volume], the inputs of the volume are set between 0-1.



4.3.5 First Round Coins

In [First Round Coins], you can set the number of coins per game need to invest per race.

1. Enter the [Arcade Operator] > [First Round Coins], the inputs of the number of coins inserted set between 0-10.



4.3.6 Second Round Coins

In [Second Round Coins], you can set the number of coins per game need to invest per race.

1. Enter the [Arcade Operator] > [Second Round Coins], the inputs of the number of coins inserted set between 0-10.



4.3.7 Winner Bonus

In [Winner Bonus], you can whether to give a Winner Bonus per race or not.

1. Enter the [Arcade Operator] > [Winner Bonus], choose “Yes” to turn on the Winner Bonus system and “No” to turn it off.



4.3.8 Clock

In [Clock], you can set the system time.

1. Enter the [Arcade Operator] > [Clock].



- Use the arrow keys to select [Clock], and then press the [START] button to expand the options of time setting.
2. Use the arrow keys to select the item you want to set, and then use the left and right arrow keys to switch the setting value, after the setup is complete, select [Settings] save [Clock] is set.
 3. After the setup is saved, select [Clock] again to hide the setting projects, and continue to operate.

4.3.9 Income

In the page [Income], you can go through the revenue-related information of the machine.

1. Enter the [Arcade Operator] > [Income], selection screen is as follows:

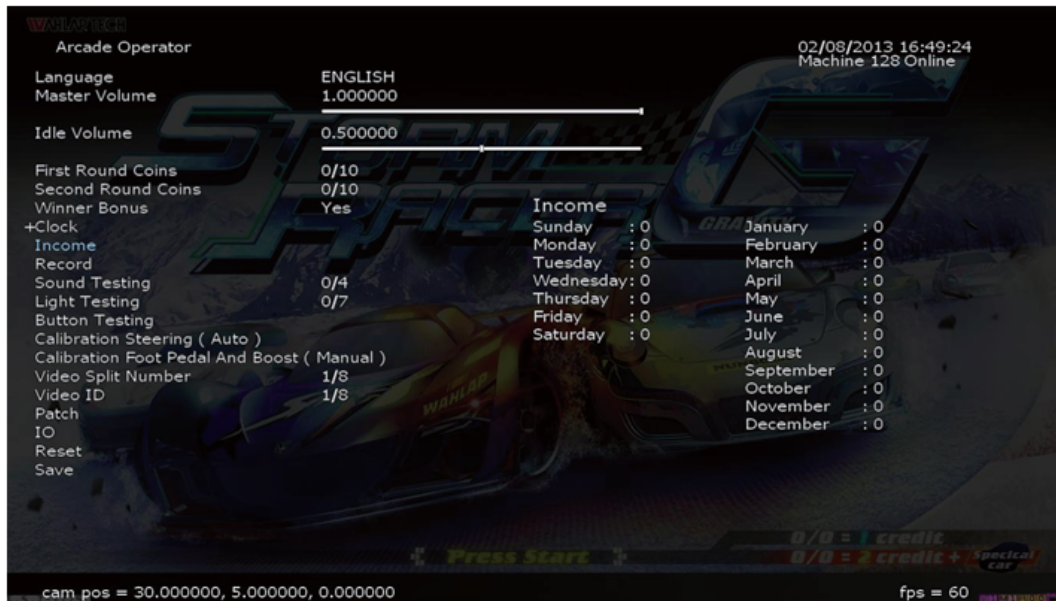

- Left Hand Side: Revenue record of the week, from Sunday to Saturday.
- Right Hand Side: Revenue record of the year, from January to December.

4.3.10 Record

In the page [Record], you can set the machine's operating system settings.

1. Enter the [Arcade Operator] > [Record], selection screen is as follows:



- [Records] records all tournament games which have been completed.
- Left Hand Side: Vehicle models: the frequency of use
- Right Hand Side: Tracks Name: the frequency of selection

4.3.11 Sound Testing

In the page [Sound Testing], you can set the machine's operating system settings.

1. Enter the [Arcade Operator] > [Sound Testing], selection screen is as follows:

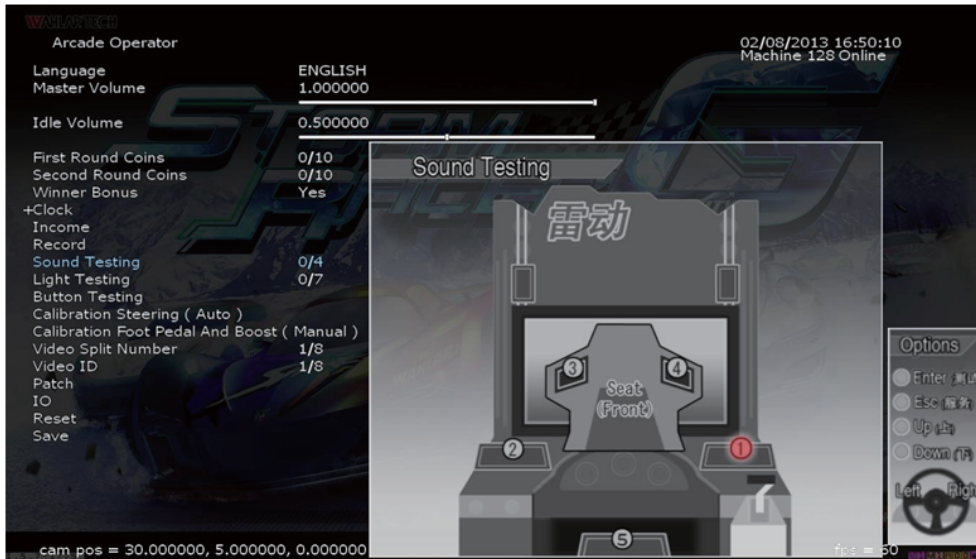

2. In [Sound Testing], use the left and right arrow keys to select the item you want to test, selected speakers (RED light) will play the test automatically and continuously.

- Normal Playback: Use the left and right arrow keys to select the set of speakers (1 to 6) you want to test with.
- If there is no sound, check whether the volume buttons are set at the minimum level, if there is still no sound, please operate the speaker troubleshooting.

4.3.12 Light Testing

In the page [Light Testing], you can test if each set of lights (1 to 7) is in normal condition.

1. Enter the [Arcade Operator] > [Light Testing], selection screen is as follows:

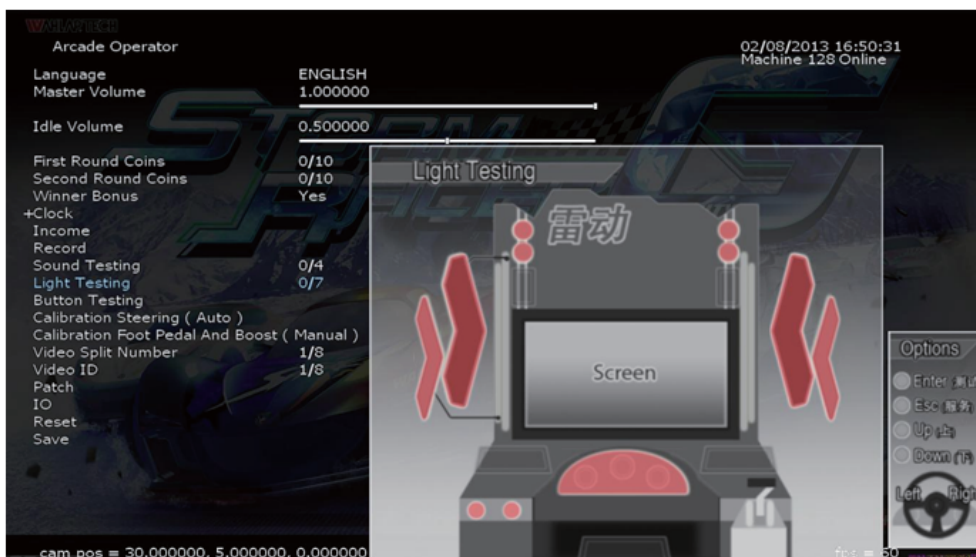

2. In [Light Testing], use the left and right arrow keys to select the item you want to test.

- This test can operate a total of eight options, from 0-7.
- The selected item (RED light) will automatically light for testing.

4.3.13 Button Testing

In the page [Button Testing], you can test if buttons are in normal condition.

1. Enter the [Arcade Operator] > [Button Testing], selection screen is as follows:

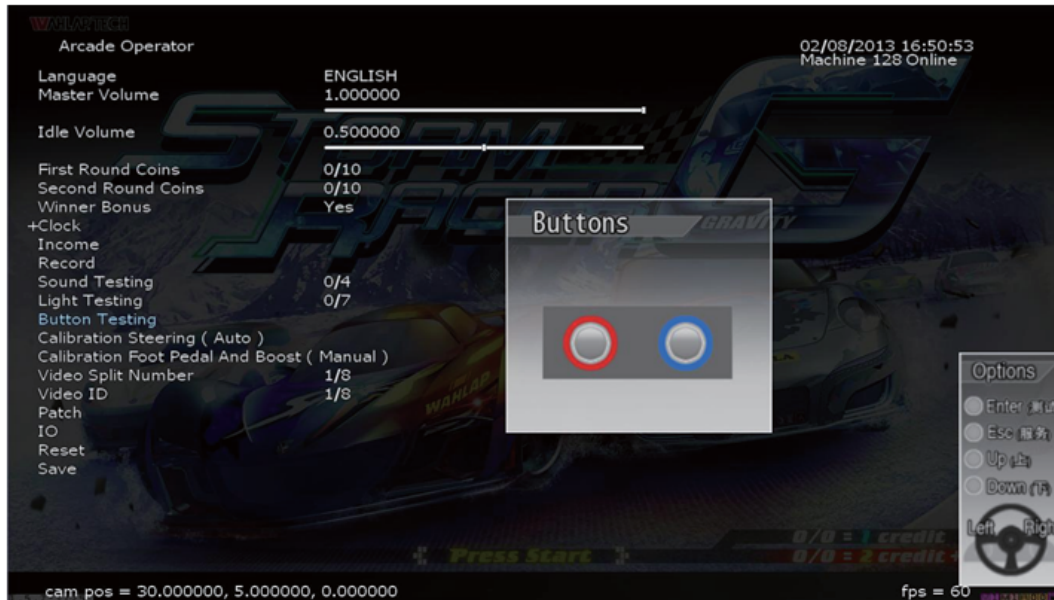

2. In [Button Testing], use the left and right arrow keys to select the item you want to test. This test has a total of four options.

- [START] button y function
- [VIEW] button function
- Accelerator handle - Push function
- Accelerator handle - Pull function

3. Press the button which is needed to be tested, the button displayed on the screen will light up in RED for normal condition.

4.3.14 Calibration Steering (Auto)

In the page [Calibration Steering (Auto)], you can test and proofread the sensitivity of the steering wheel and handling.

1. Enter the [Arcade Operator] > [Calibration Steering (Auto)], selection screen is as follows:

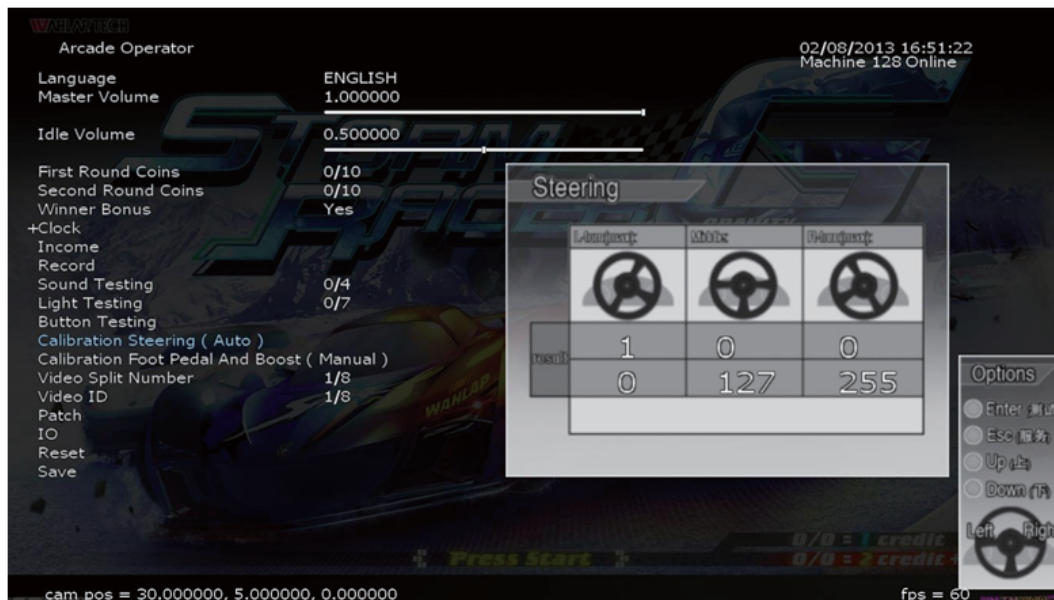

2. In [Calibration Steering (Auto)], the steering wheel will calibrate automatically to show the test value.

- This calibration project is divided into three categories:

Left in Most-Valued: Left-turn torque of the steering wheel

Center: the steering wheel in the median position;

Right in Most-Valued: Right-turn torque of the steering wheel

3. When turning the steering wheel, numerical changes with the rotation rate. When turning to the Most-Right, the indicated value is about 255; 0 when turning to the Most-Left.

4. The value of the steering wheel is displayed in the Calibration Result column. The First column is the Actual-calibrated value; the Second column is the Ideal-calibration value.

5. The calibration value must be in the range of 5% of the ideal value, or criticized as sub-standard.

6. The lowest column will be displaying the Rating Symbol:

“✓” tick as qualified; “X” cross as sub-standard, adjustment is required.

4.3.15 Calibration Foot Pedal (Manual)

In the page [Calibration Foot Pedal (Manual)], you can test and proofread the sensitivity of the foot Pedal.

1. Enter the [Arcade Operator] > [Calibration Foot Pedal (Manual)], selection screen is as follows:

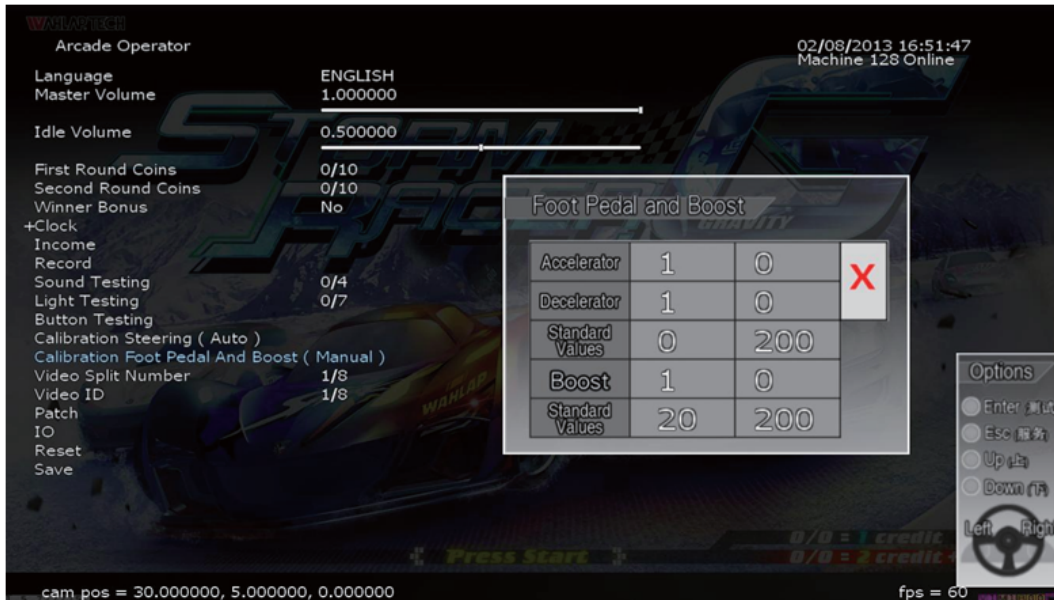

2. There are two projects in this calibration operation:

- Throttle: By stepping the throttle, the value will be changed. By stepping the throttle to the most, the value should be around 255; If the throttle is not be stepped, the value should be around 0.
- Brake: By stepping the brake, the value will be changed. By stepping the brake to the most, the value should be around 255; If the throttle is not be stepped, the value should be around 0.

3. The maximum and minimum values of the throttle and brake should be within 10% of the ideal value.

The lowest column will be displaying the Rating Symbol:

“✓” tick as qualified; " X " cross as sub-standard, adjustment is required.

4.3.16 Video Split Number

In the page [Video Split Number], you can choose how many machines you want to split the video as display.

1. Enter the [Arcade Operator] > [Video Split Number], selection from 1 to 8 machines.



2. There are three displays in this operation:
 - Machine: The machine number.
 - Video: The sequence of video in the machine.
 - Network: The network status: On or Off

4.3.17 Video ID

In the page [Video ID], you can set the video ID of the machine.

1. Enter the [Arcade Operator] > [Video ID], selection from 1 to 8 machines.



2. There are three displays in this operation:
 - Machine: The machine number.
 - Video: The sequence of video in the machine.
 - Network: The network status: On or Off

4.3.18 Patch

In the page [Patch], you can do the patching.

1. Enter the [Arcade Operator] > [Patch], selection screen is as follows:



4.3.19 IO

In the page [IO], you can check if there is any IO device.

1. Enter the [Arcade Operator] > [IO], selection screen is as follows:



4.3.20 Reset

In the page [Reset], you can set up to restore all settings to the original settings.

1. Enter the [Arcade Operator] > [Reset], selection screen is as follows:



2. Select [Reset] and then press the [START] button in the arcade. All settings will be restored to default, all arcade records will be cleared.

4.3.21 Save

In the page [Save], you can save all the settings in the setup.

1. Enter the [Arcade Operator] > [Save], selection screen is as follows:



2. Select [Save] and then press the [START] button, all settings will be saved.

4.3.22 Game-Play Screen Information

In the below of the [Game-Play screen], 2 pieces of information about the game and machine is shown.



1. Down Left-corner.



- Main Version: 1.5.9
- Build Version: 1786

2. Down Right-corner



- V – Video ID: 1
- M – No. of machines connected LAN: 1
- R : (for development purpose)

5. Maintenance and Service

5.1 Maintenance and service

Even though the machine works normally for a long time, the fault will occur. Therefore, please perform routine check and maintenance concerning the following to ensure a long-term use.

■ External Inspection

- Stick “Warning” stickers correctly, keep it legible.
- Firmly tighten the bolt for each adjuster.
- Tighten screws for speaker assembly.
- Tighten the signboard firmly.
- Check if the screws fixing the parts loose.
- Check if the connectors loose or missing.

■ Operation Inspection (With power on)

- Sound is normally emitted from the speakers or not.
- Fluorescent lamps and button lamps light up or not
- Coin acceptor works properly or not.
- Lifting and falling devices work properly or not.
- YZ sensor works properly or not.

After completing all the checks, operate the game again and check the above items with full care!

■ Servicing (conducted by a technician only)

- Cut off the main power supply to avoid injury or electric shock when performing maintenance.
- Please contact our service center when performing any work that is not specified in this Manual, and follow the instruction provided by the service center.
- For consumables and spare parts (including screws), please use products specified by Wahlap Technology.
- Even though the main power is cut off, there is still high temperature and high pressure in the power board and the monitor. The person will be burnt or get an electric shock if he touches such parts. Please pay full attention to avoid contact.
- Be sure to cut off the main power when you alter a spare part or unplug a connector.

5.2 Part Replacement

5.2.1 Replacement of acrylic signboard



1. Remove the screws on the acrylic signboard for replacement.

5.2.2 Replacement of fluorescent plate

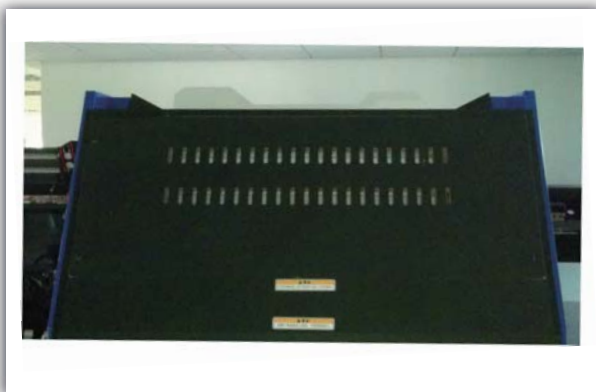

1. Open the back door shown in the figure.
2. Reverse the opened back door and find the fluorescent tube requiring being replaced for replacement.

5.2.3 Replacement of top light box

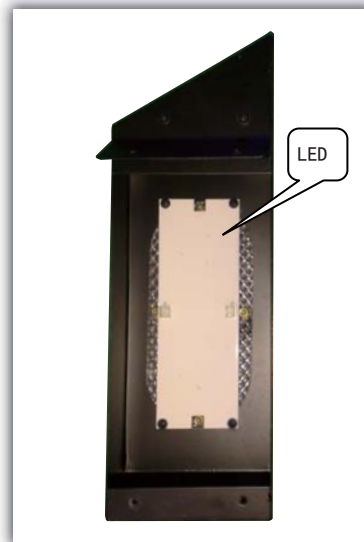
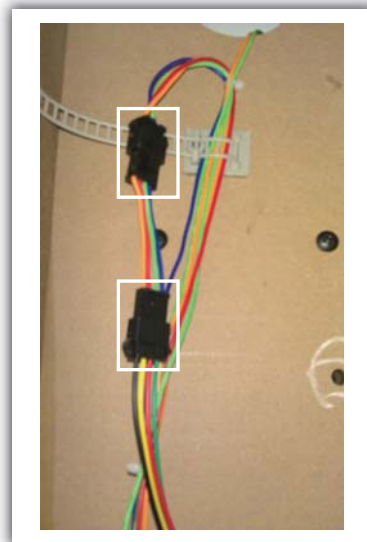

1. After removing the screws used to fix the light box on the top of the machine, open the back door of the machine.
2. Find the connecting wire of the light box, pull out the rubber seat terminals and remove the light box.
3. Remove the fluorescent plate on the light box for replacement.

5.2.4 Key replacement

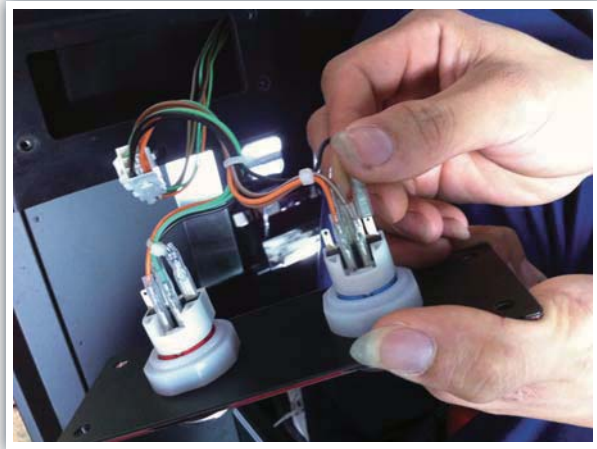
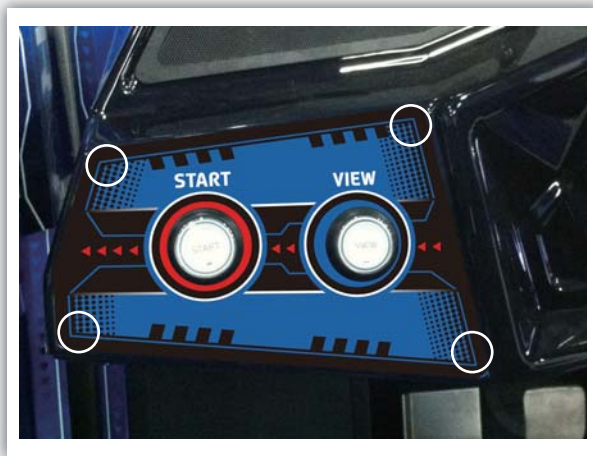

1. Remove the fixing screws of key board.
2. Remove the keyboard, pull out the terminals and replace the key.

5.2.5 Replacement of pick-up head



1. After removing the acrylic panel, remove the fixing screws on the pick-up head.
2. Open the back door and remove the fixing screws on the rear cover of the pick-up head.
3. Remove the pick-up head and fixing components and replace the pick-up head after removing the fixing screws.

5.2.6 Replacement of coin acceptor

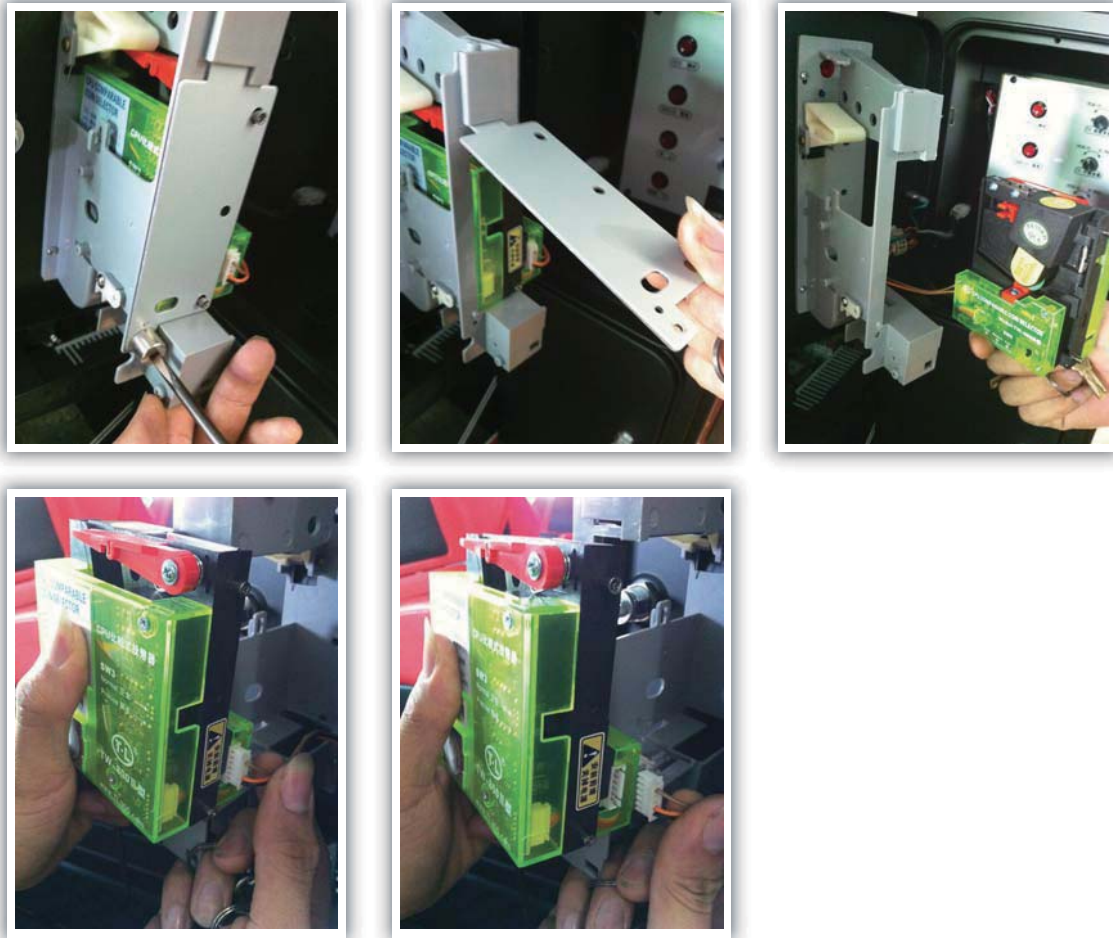

1. Remove the fixing screws with the slotted screwdriver, take out the stop plate, remove the coin acceptor, pull out the terminals and replace the coin acceptor.

6. Assembly

6.1 Assembly tree diagram

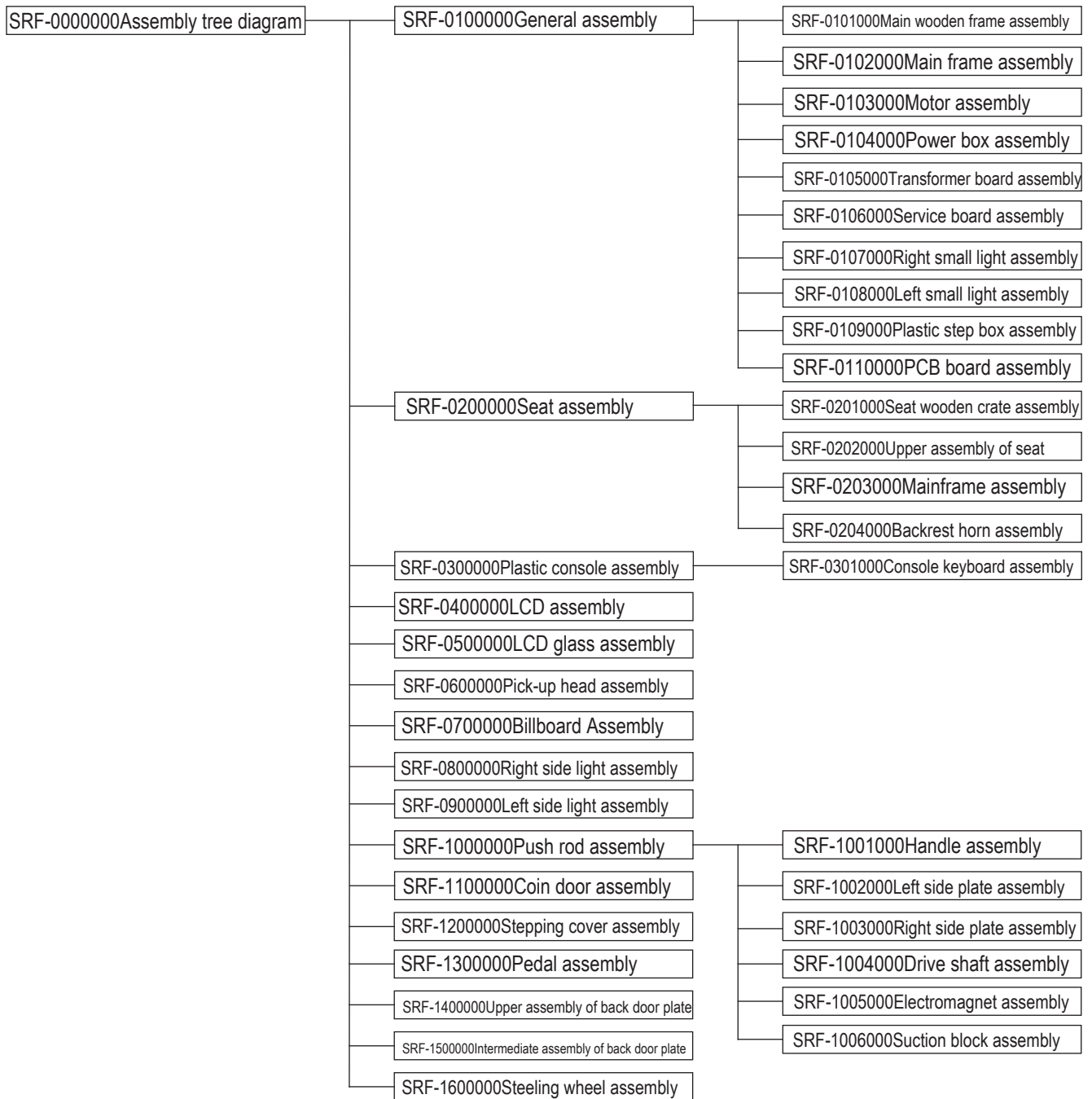

6.2 General assembly(一)

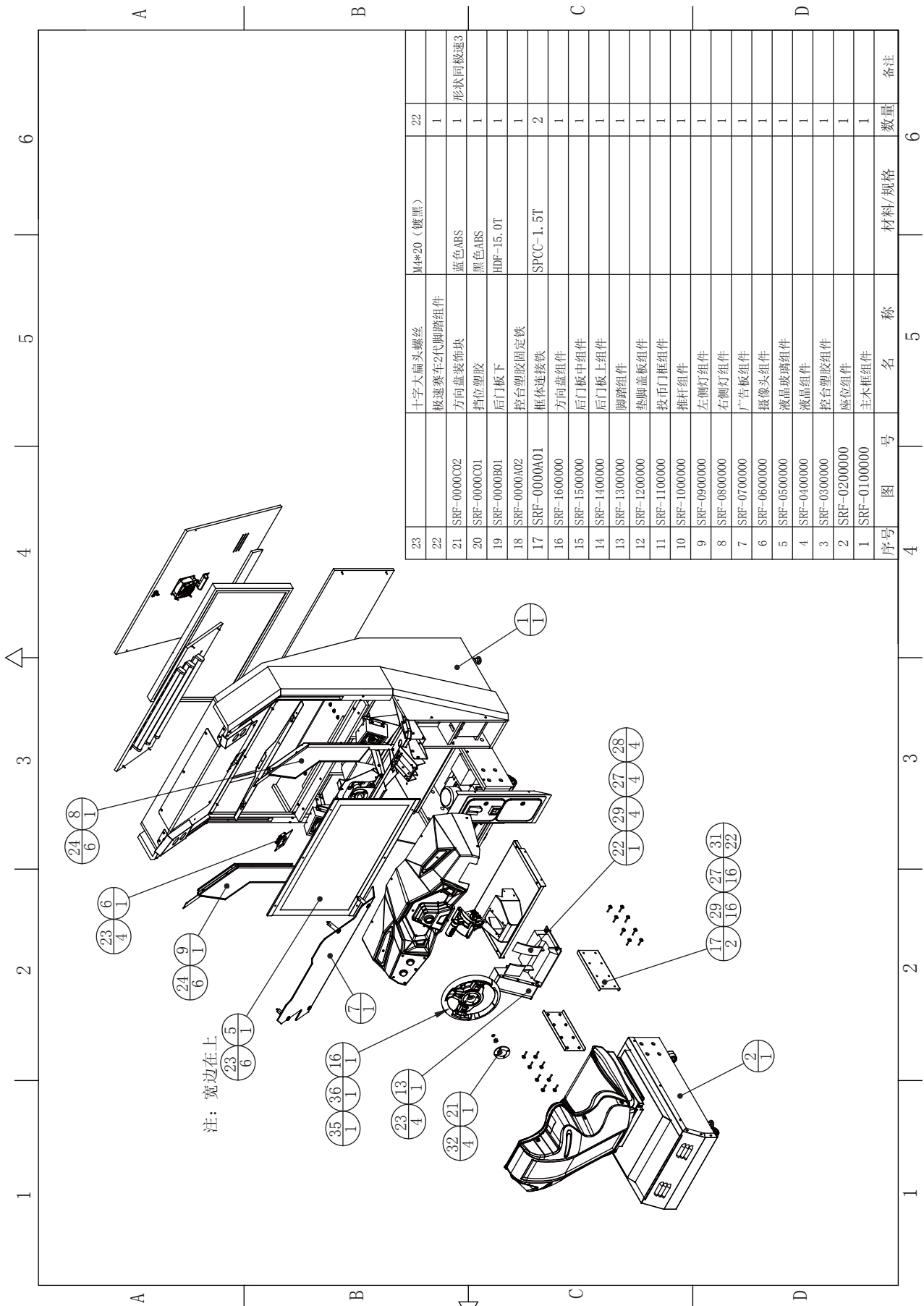

General assembly(二)

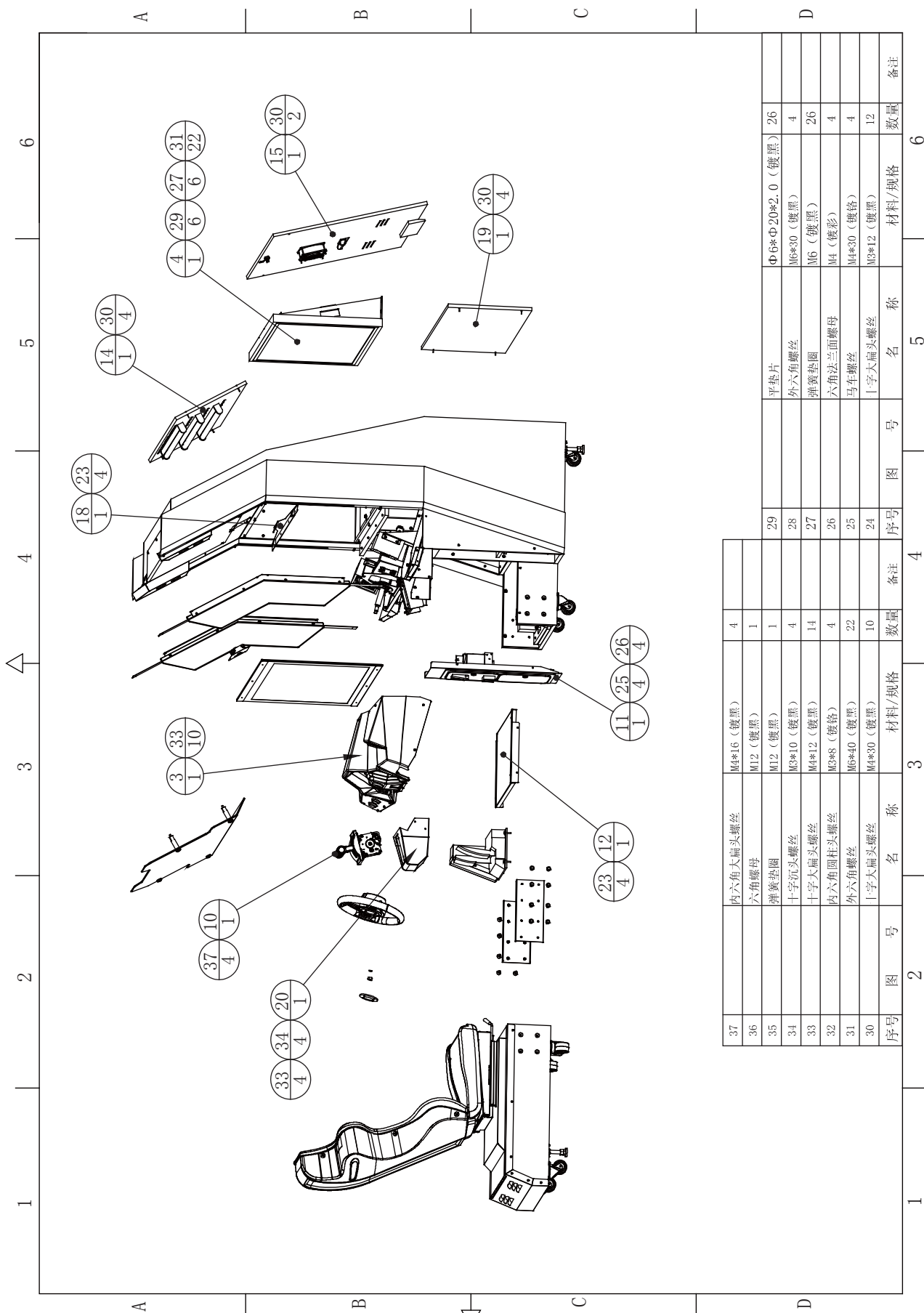

6.2.1 Main wooden frame assembly (一)

序号	图号	名称	材料/规格	数量	备注
27		喇叭组合音箱	6.5吋 低音炮音箱 (极速用)	1	
26	sr1-0000a03	喇叭固定铁	SPCC-1.5	2	
25	SRF-0100D01	灯箱亚克力	PMMA-3.0T	1	
24	SRF-0100A14	控台下盖铁		1	
23	SRF-0100A13	摄像头挡光板	SPCC-1.0T	1	
22	SRF-0100A12	低音喇叭网	SPCC-1.2T	1	
21	SRF-0100A11	脚踏下盖板	SPCC-1.2T	1	
20	SRF-0100A10	塑胶边固定小铁	SPCC-1.2T	1	
19	SRF-0100A09	控台加固铁右	SPCC-2.0T	2	
18	SRF-0100A08	控台加固铁左	SPCC-2.0T	2	
17	SRF-0100A07	控台固定铁		1	
16	SRF-0100A06	玻璃固定横梁	SPCC-1.2T	1	
15	SRF-0100A05	变压器板卡铁	SPCC-1.5T	1	
14	SRF-0100A04	液晶下固定角铁	SPCC-2.0T	2	
13	SRF-0100A03	左侧柱铁	SPCC-1.2T	1	
12	SRF-0100A02	右侧柱铁	SPCC-1.2T	1	
11	SRF-0100A01	护角铁	SPCC-1.2T	1	
10	SRF-0110000	PCB板组件		1	
9	SRF-0109000	挡位塑胶盒组件		1	
8	SRF-0108000	左小灯合组件		1	
7	SRF-0107000	右小灯合组件		1	
6	SRF-0106000	音箱组件		2	
5	SRF-0105000	服务板组件		1	
4	SRF-0104000	变压器板组件		1	
3	SRF-0103000	电源盒组件		1	
2	SRF-0102000	马达组件		1	
1	SRF-0101000	主框架组件		1	

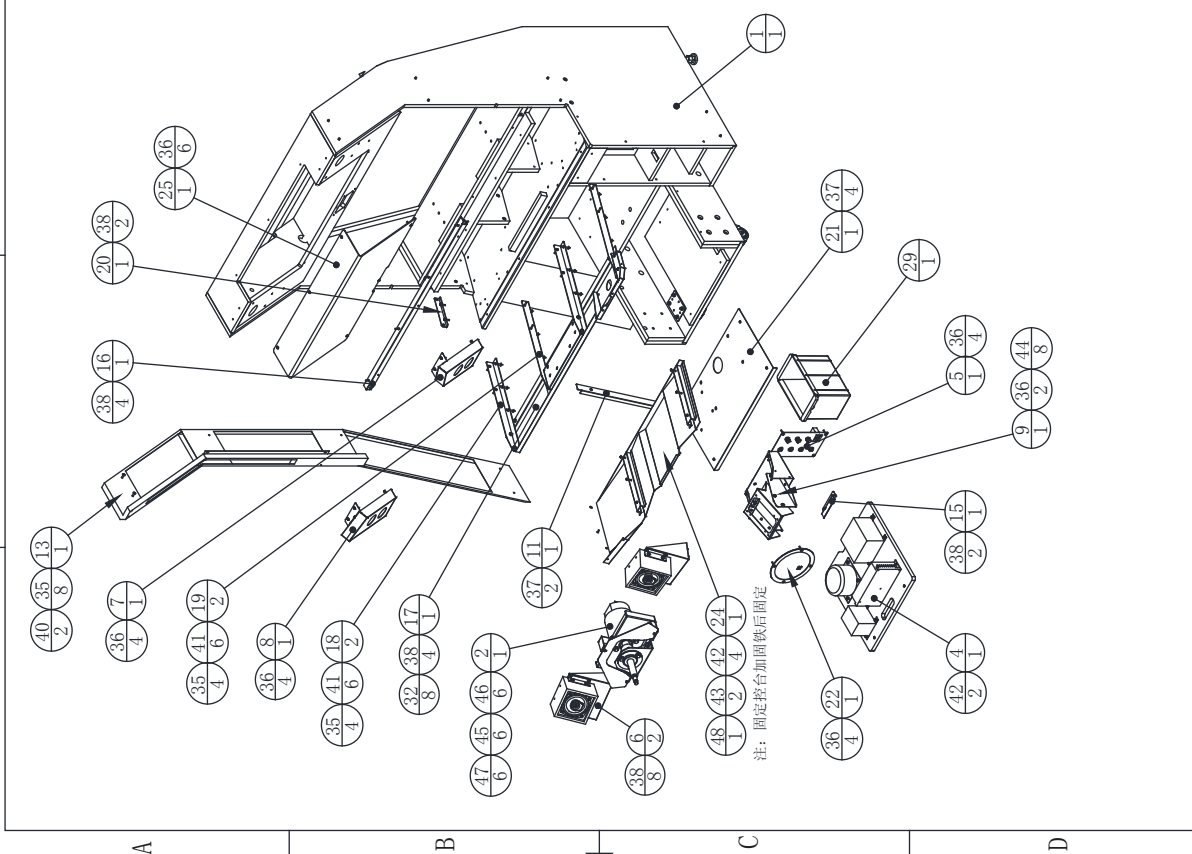

Main wooden frame assembly (二)

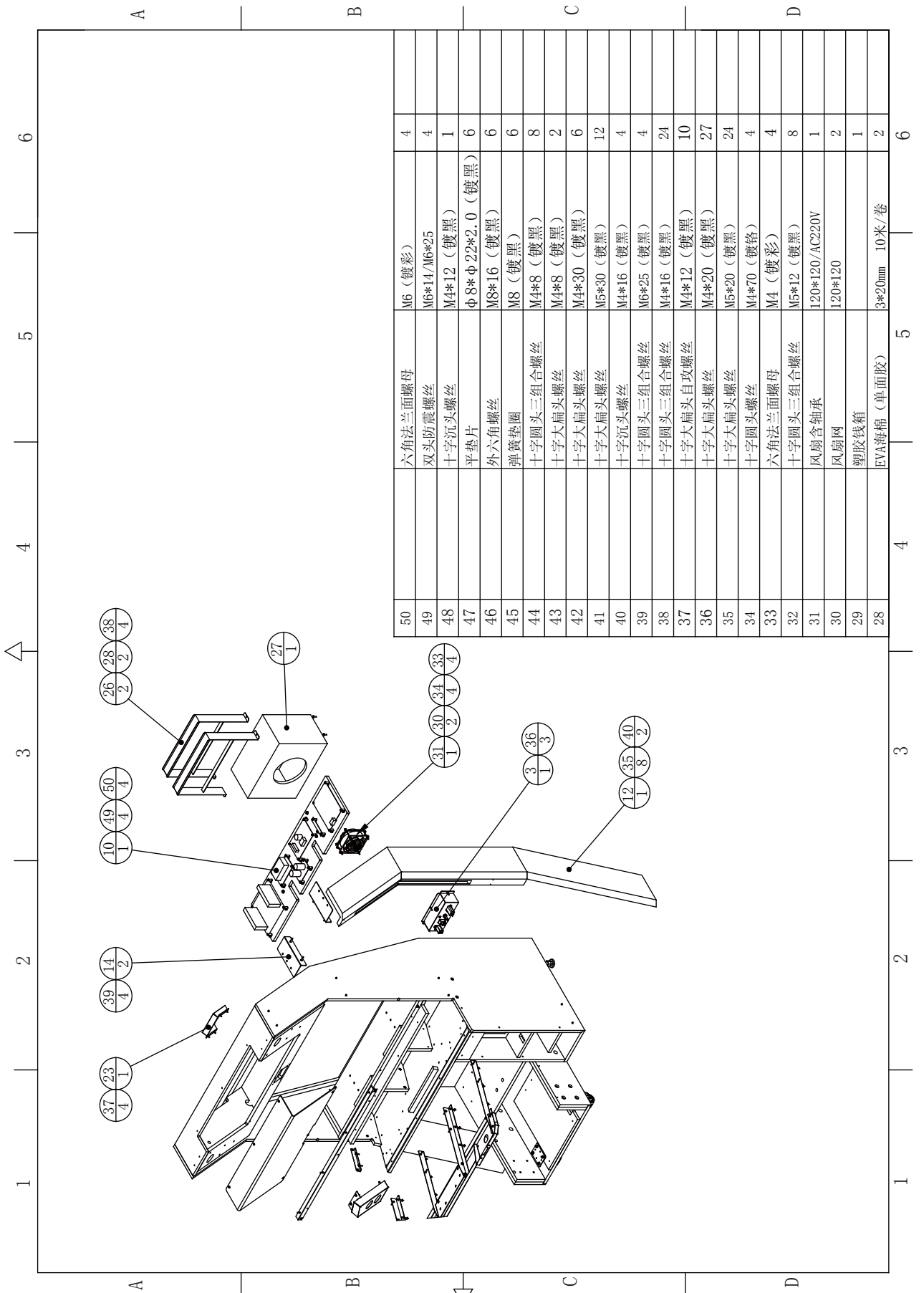

6.2.2 Main frame assembly

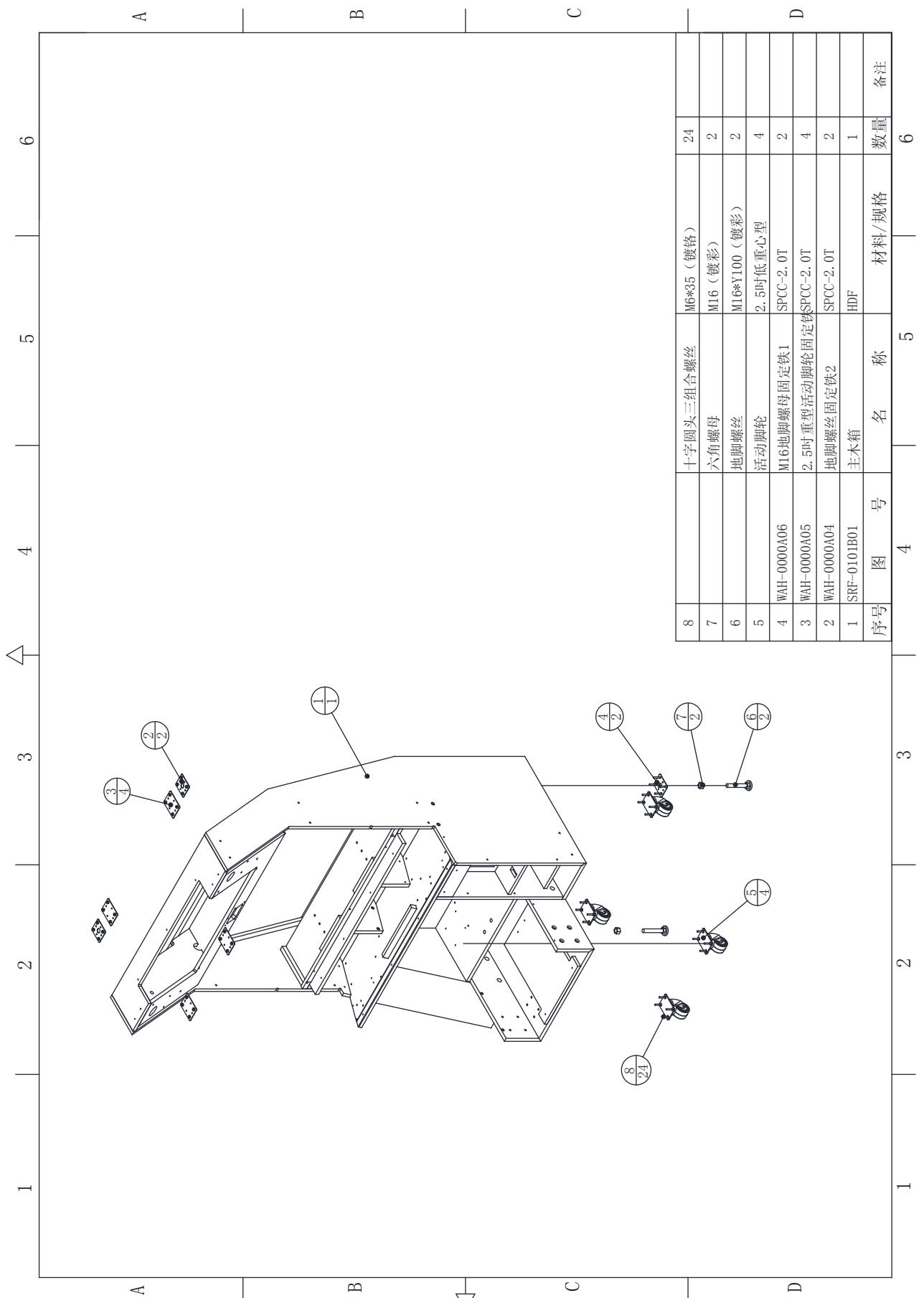

6.2.3 Motor assembly

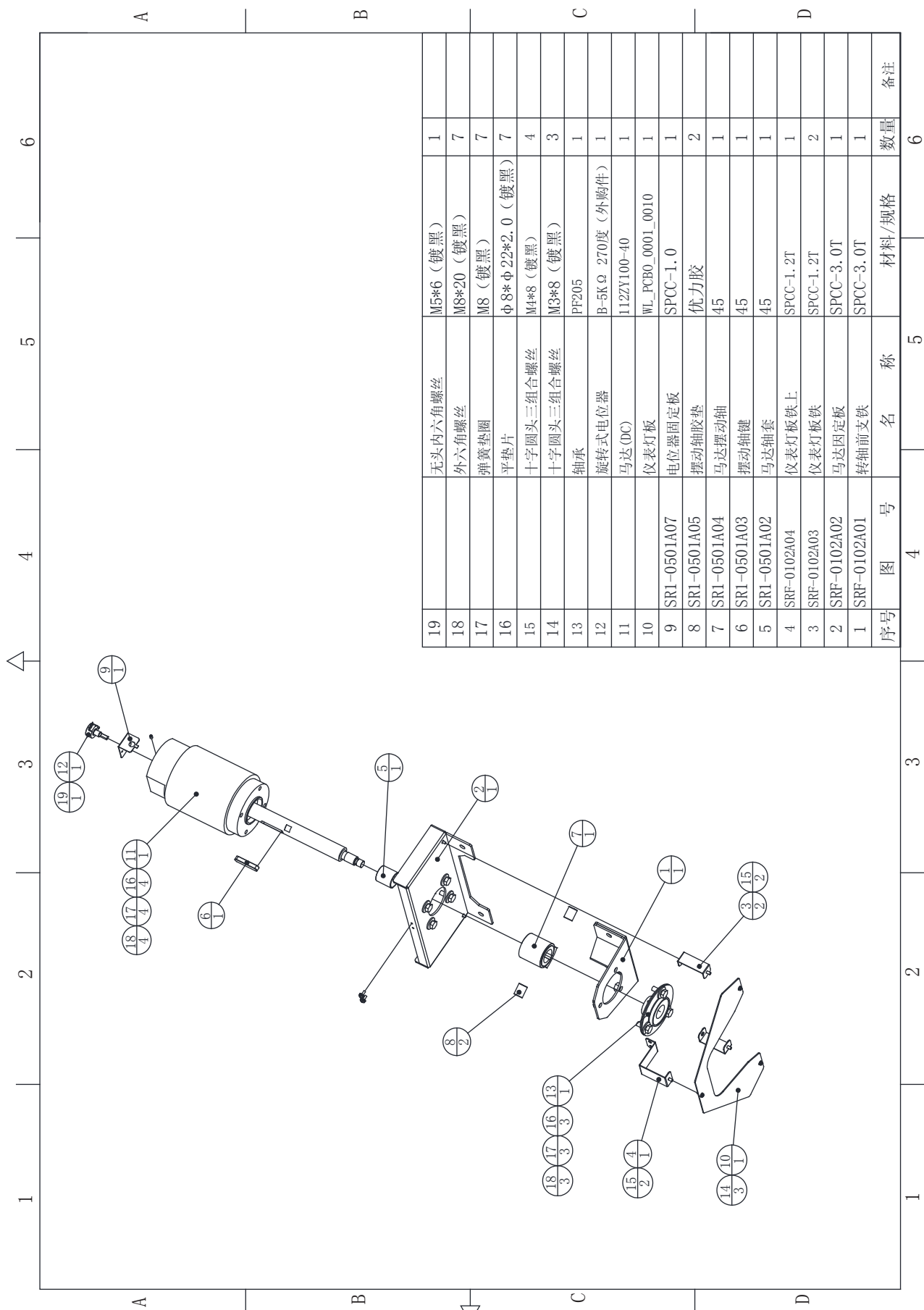

6.2.4 Power box assembly

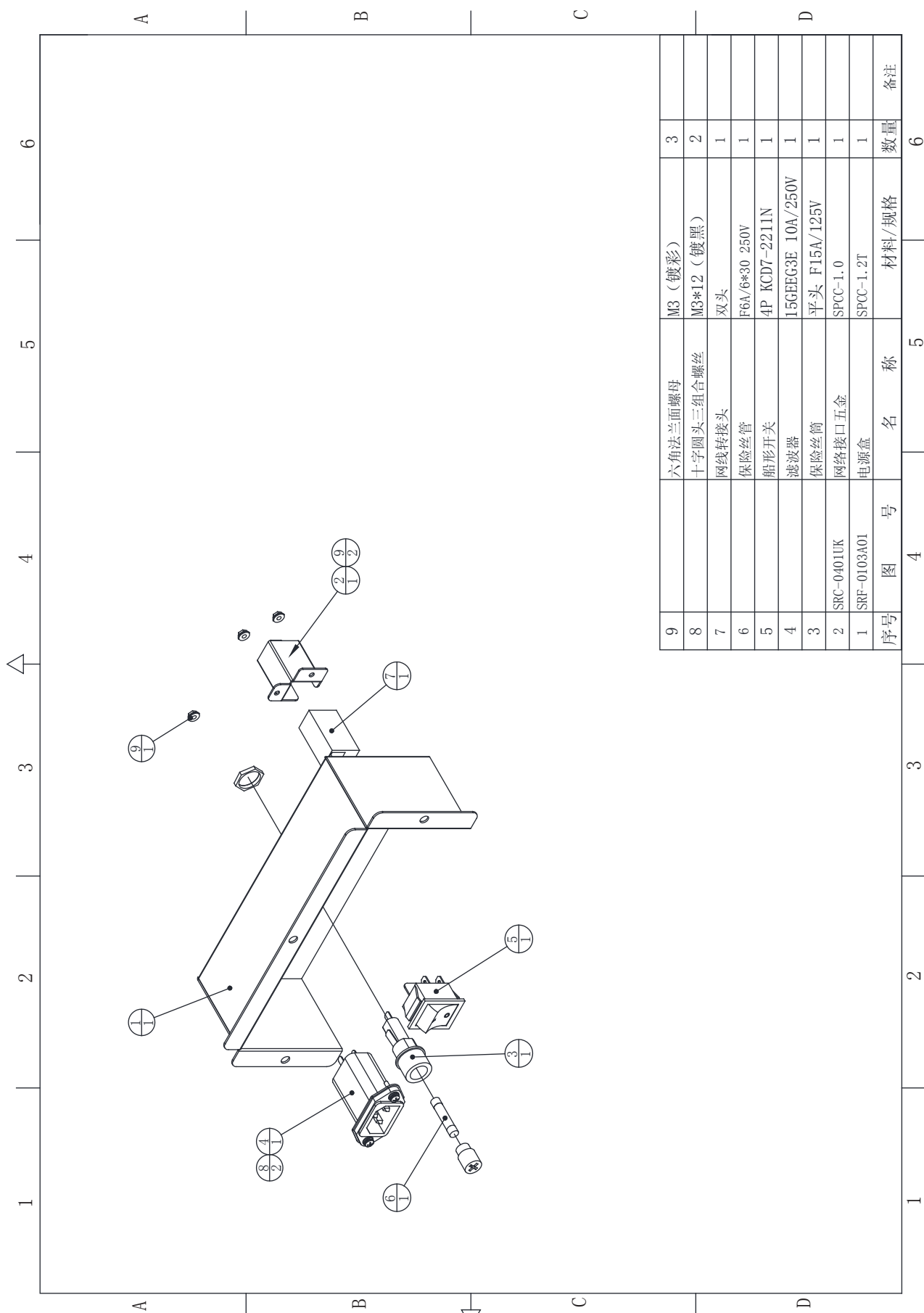

序号	图号	名称	材料/规格	数量	备注
9		六角法兰面螺母	M3 (镀彩)	3	
8		十字圆头三组合螺丝	M3*12 (镀黑)	2	
7		网线转接头	双头	1	
6		保险丝管	F6A/6*30 250V	1	
5		船形开关	4P KCD7-2211N	1	
4		滤波器	15GEEG3E 10A/250V	1	
3		保险丝筒	平头 F15A/125V	1	
2	SRC-0401UK	网络接口五金	SPCC-1.0	1	
1	SRF-0103A01	电源盒	SPCC-1.2T	1	

6.2.5 Transformer board assembly

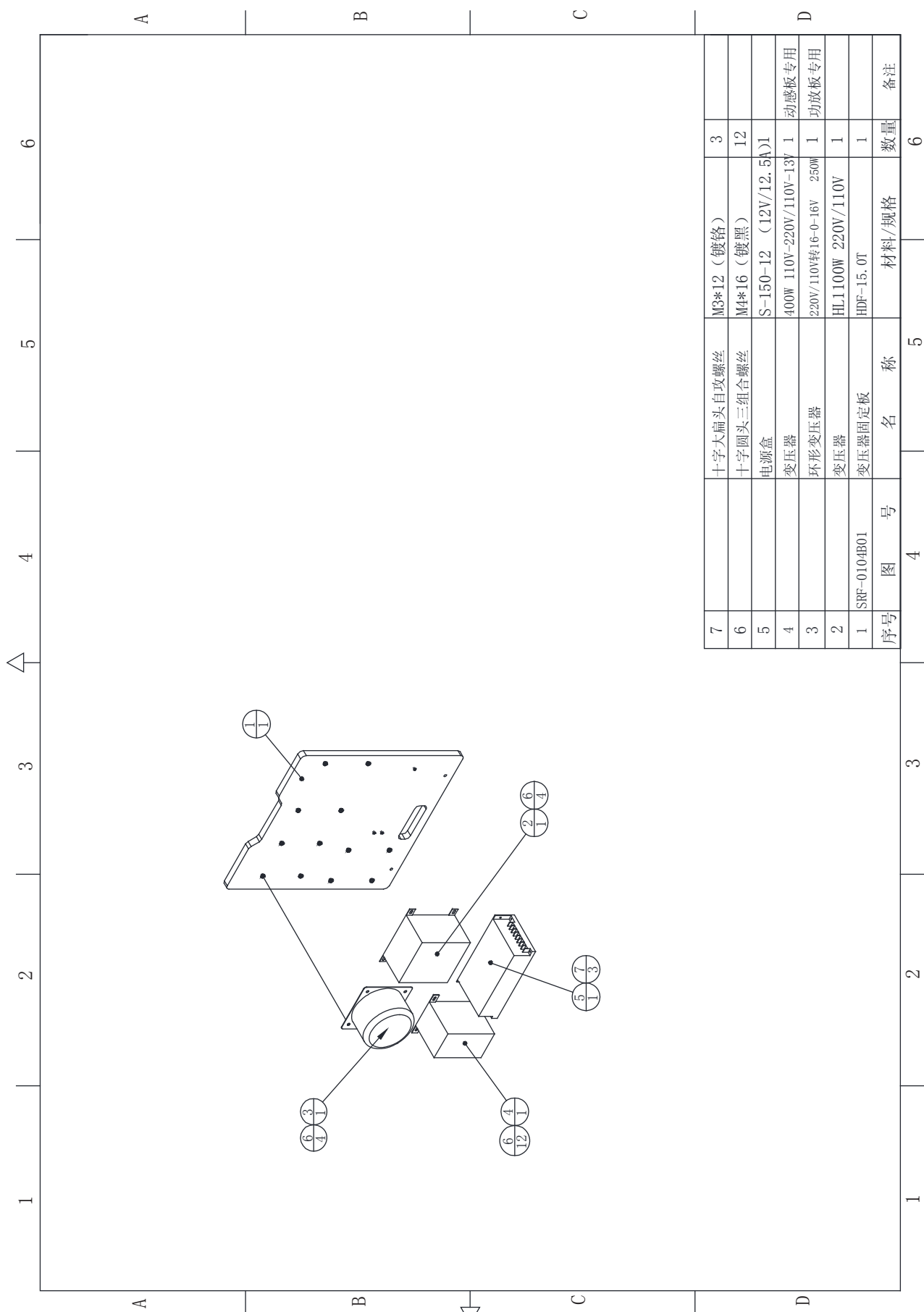

6.2.6 Service board assembly

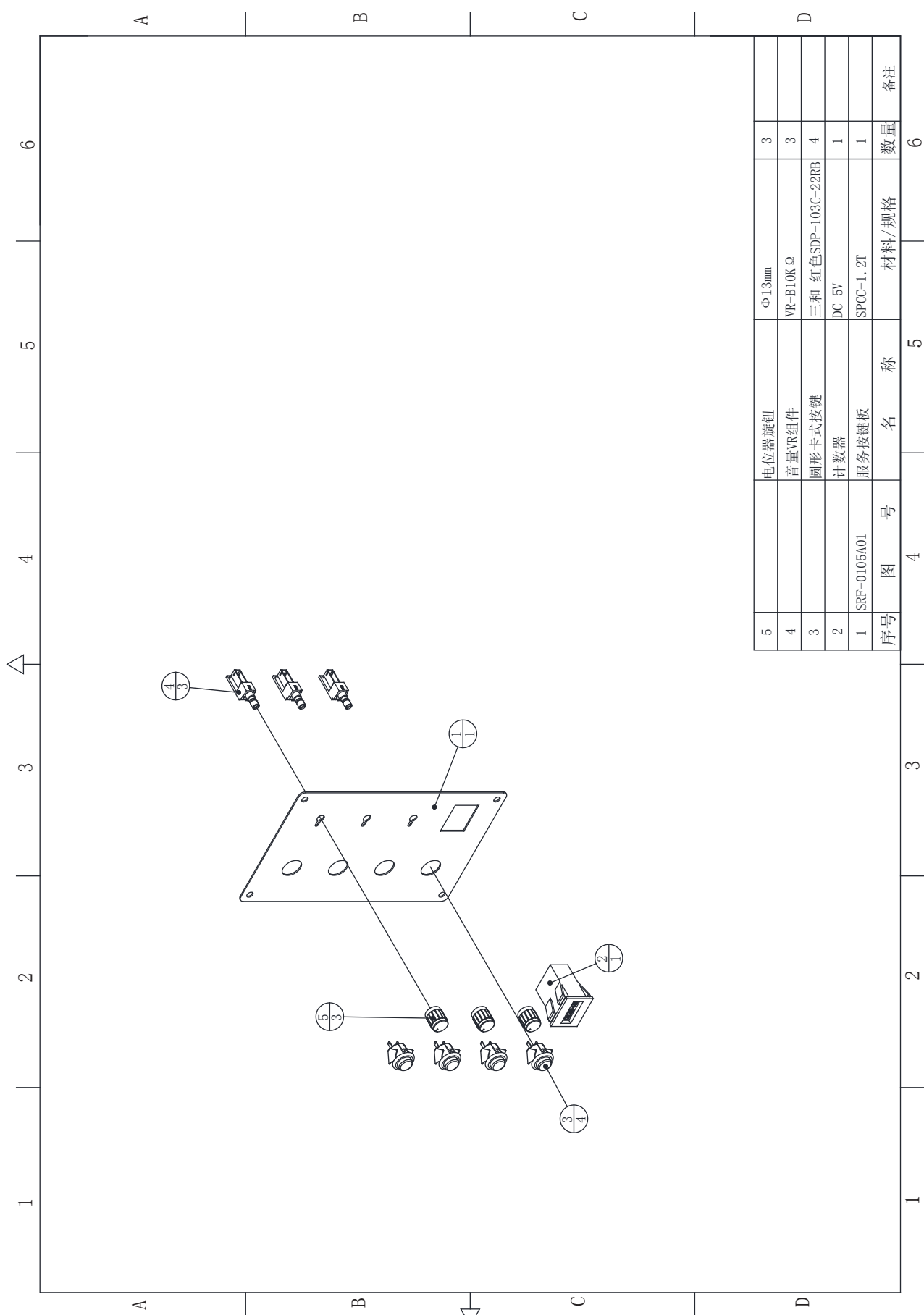

6.2.7 Speaker assembly

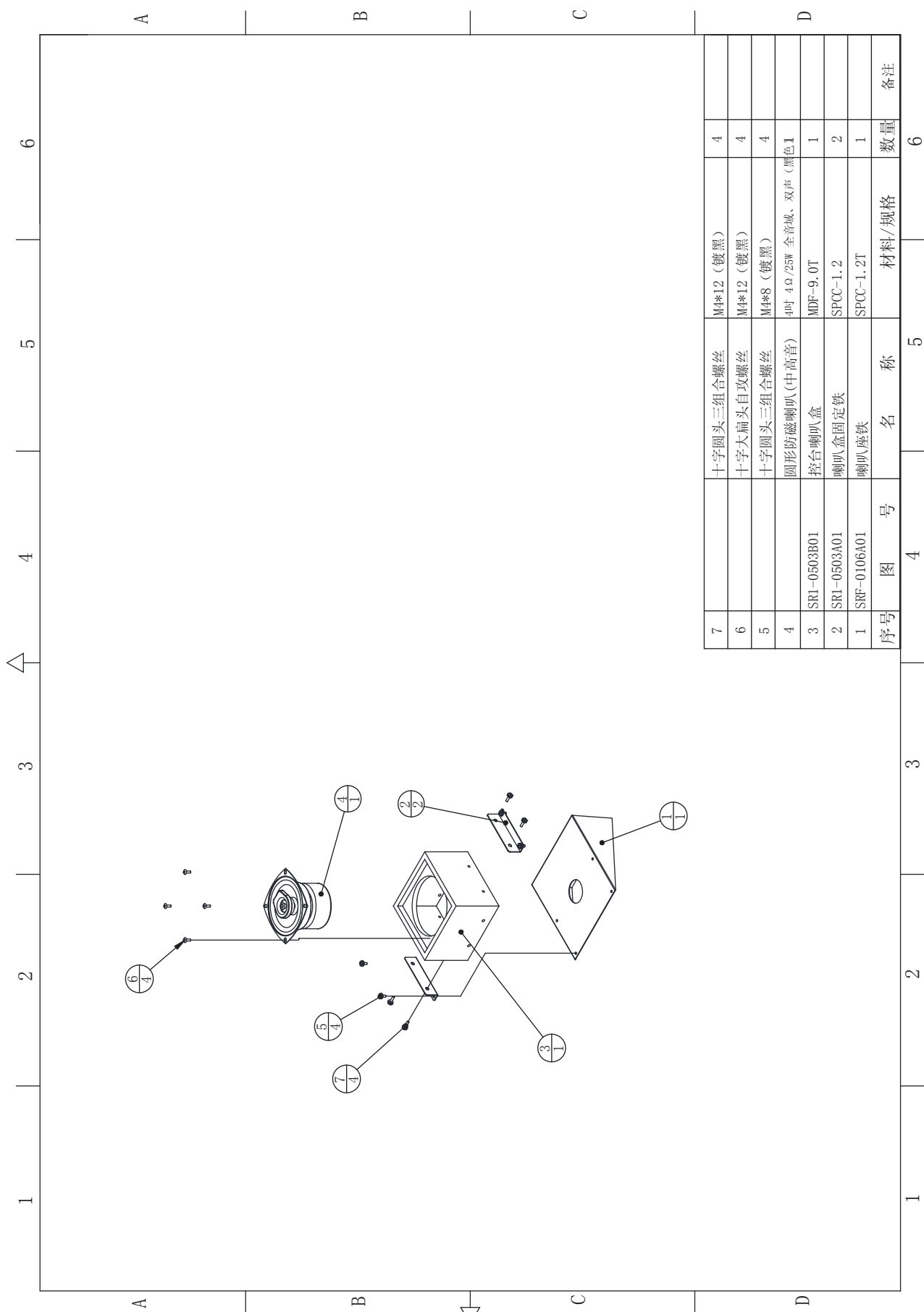

6.2.9 Left small light assembly

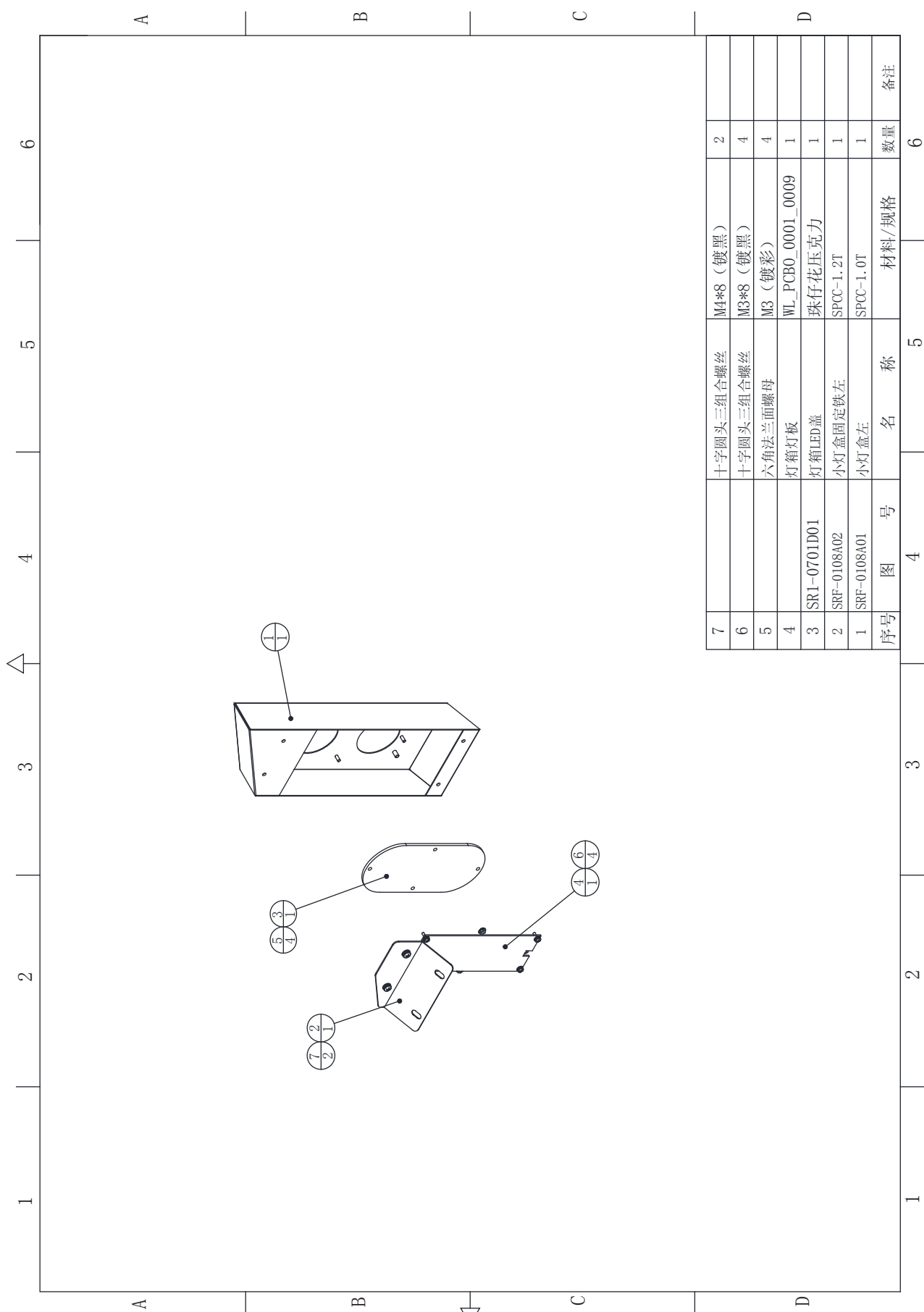

6.2.10 Plastic step box assembly

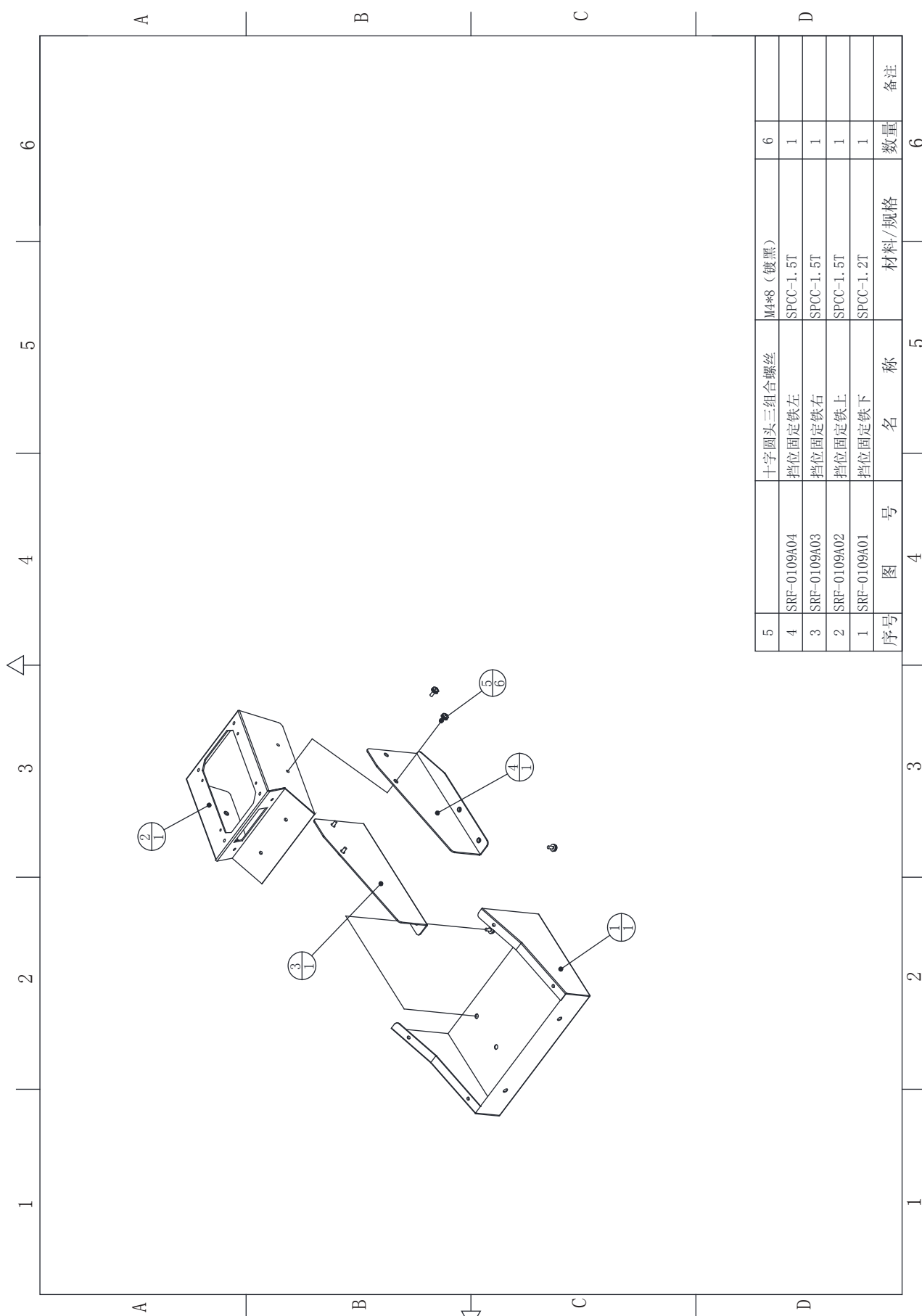

6.2.11 PCB board assembly

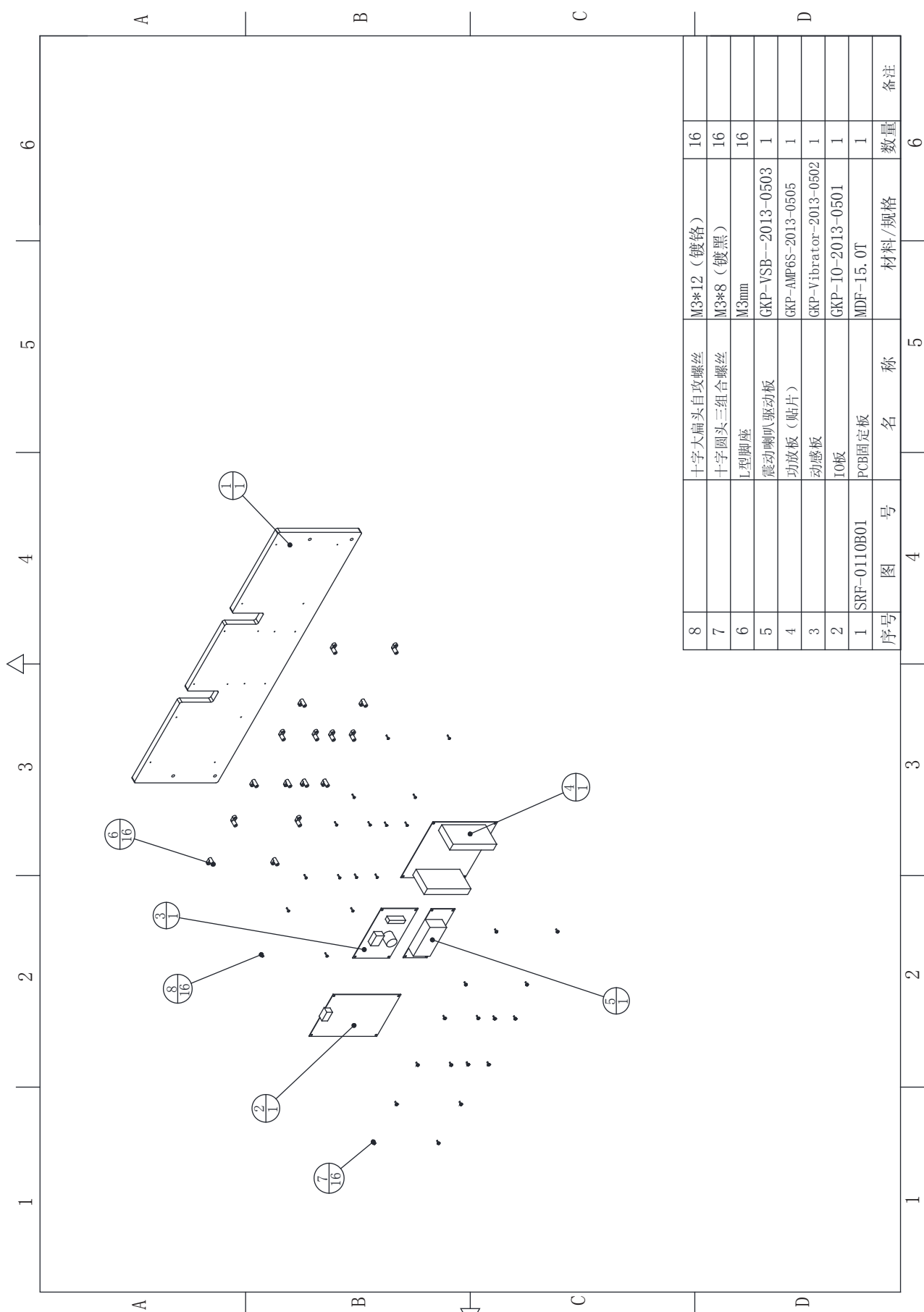

序号	图号	名称	材料/规格	数量	备注
8		十字大扁头自攻螺丝	M3*12 (镀铬)	16	
7		十字圆头三组合螺丝	M3*8 (镀黑)	16	
6		L型脚座	M3mm	16	
5		震动喇叭驱动板	GKP-VSB--2013-0503	1	
4		功放板 (贴片)	GKP-AMP6S-2013-0505	1	
3		动感板	GKP-Vibrator-2013-0502	1	
2		IO板	GKP-IO-2013-0501	1	
1	SRF-0110B01	PCB固定板	MDF-15.0T	1	
		名称	材料/规格	数量	备注

6.3 Seat assembly

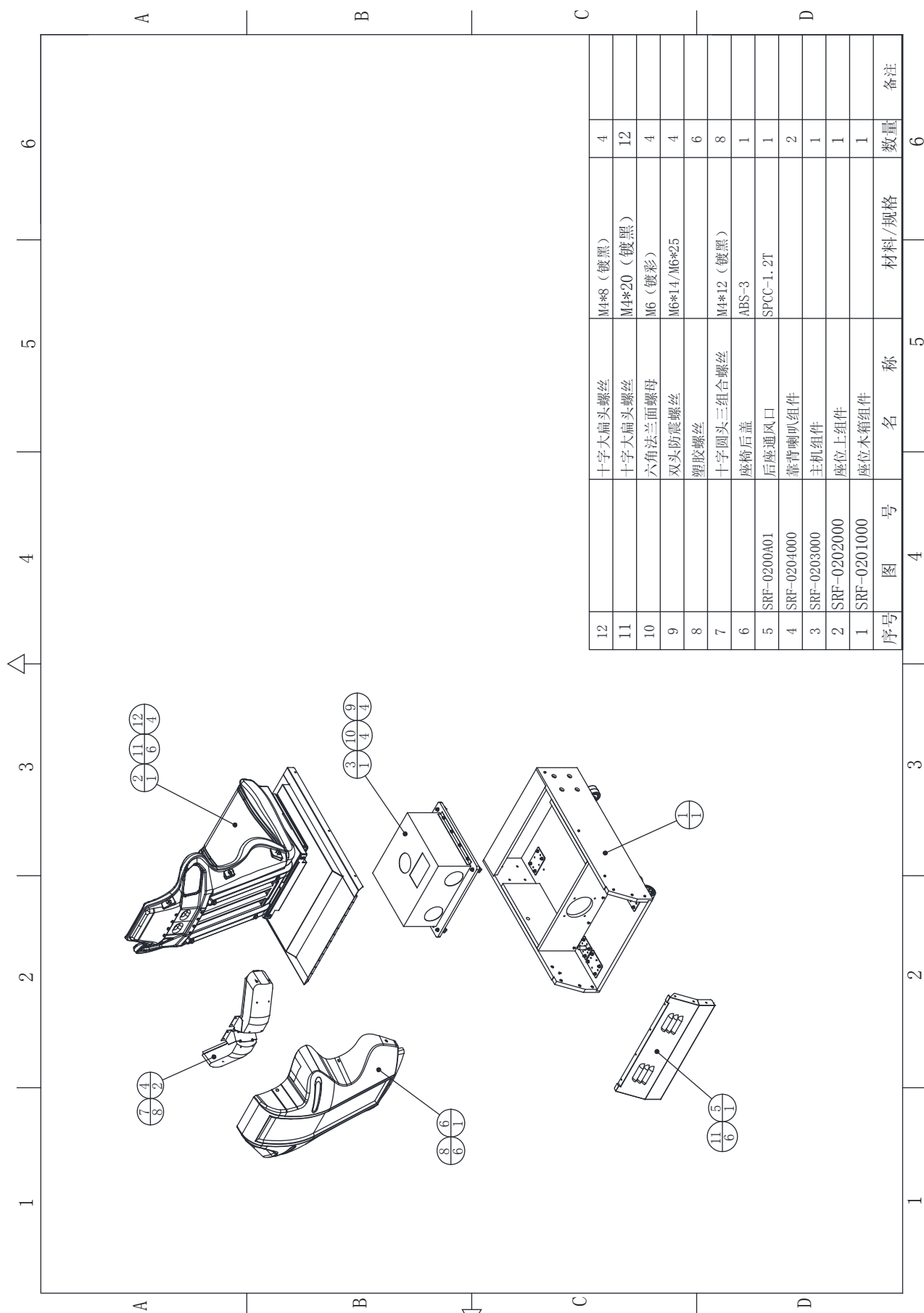

6.3.1 Seat wooden crate assembly

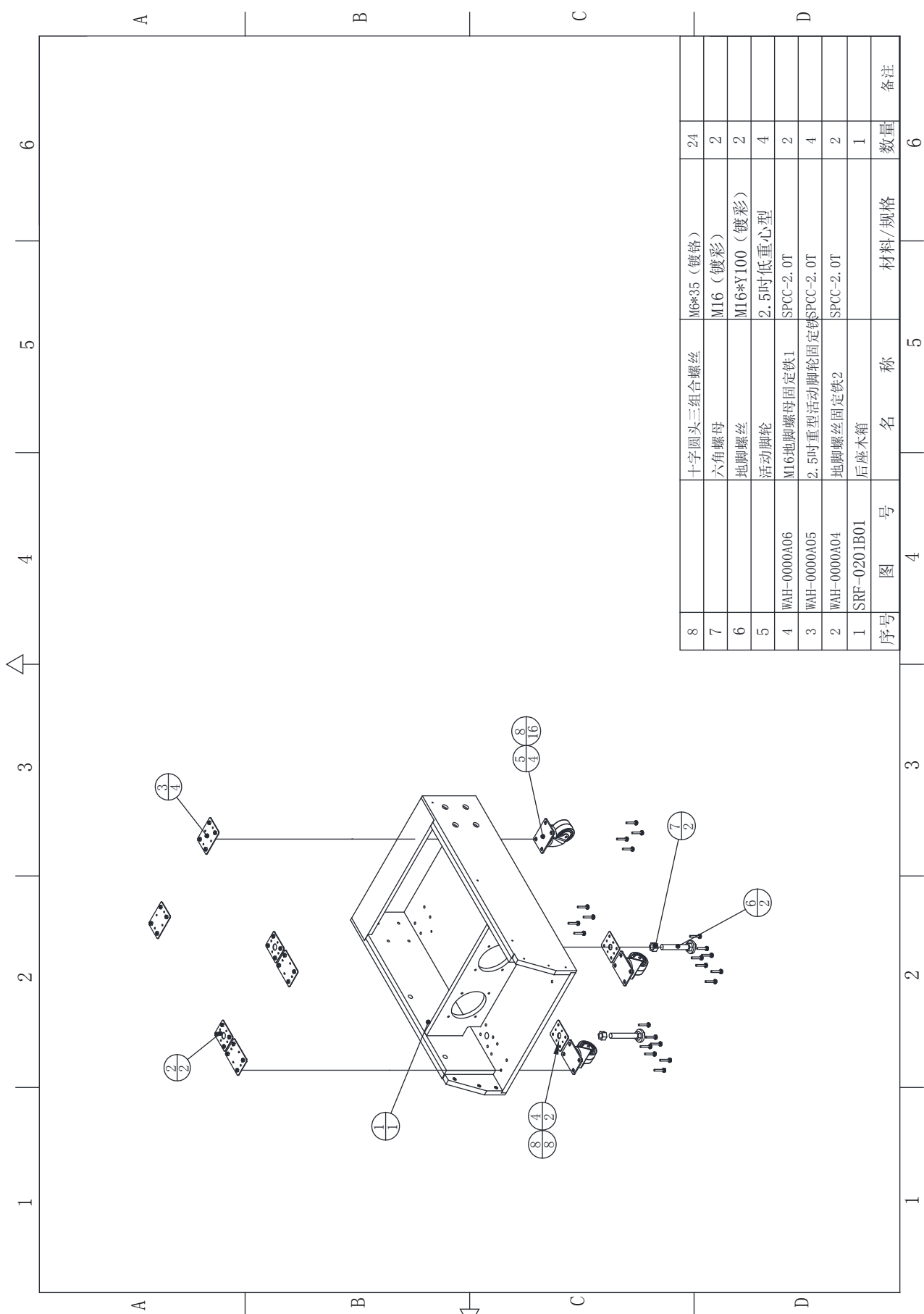

序号	图号	名称	材料/规格	数量	备注
8		十字圆头三组合螺丝	M6*35 (镀锌)	24	
7		六角螺母	M16 (镀锌)	2	
6		地脚螺丝	M16*Y100 (镀锌)	2	
5		活动脚轮	2.5吋低重心型	4	
4	WAH-0000A06	M16地脚螺母固定铁1	SPCC-2.0T	2	
3	WAH-0000A05	2.5吋重型活动脚轮固定铁	SPCC-2.0T	4	
2	WAH-0000A04	地脚螺丝固定铁2	SPCC-2.0T	2	
1	SRF-0201B01	后座木箱		1	

6.3.2 Upper assembly of seat

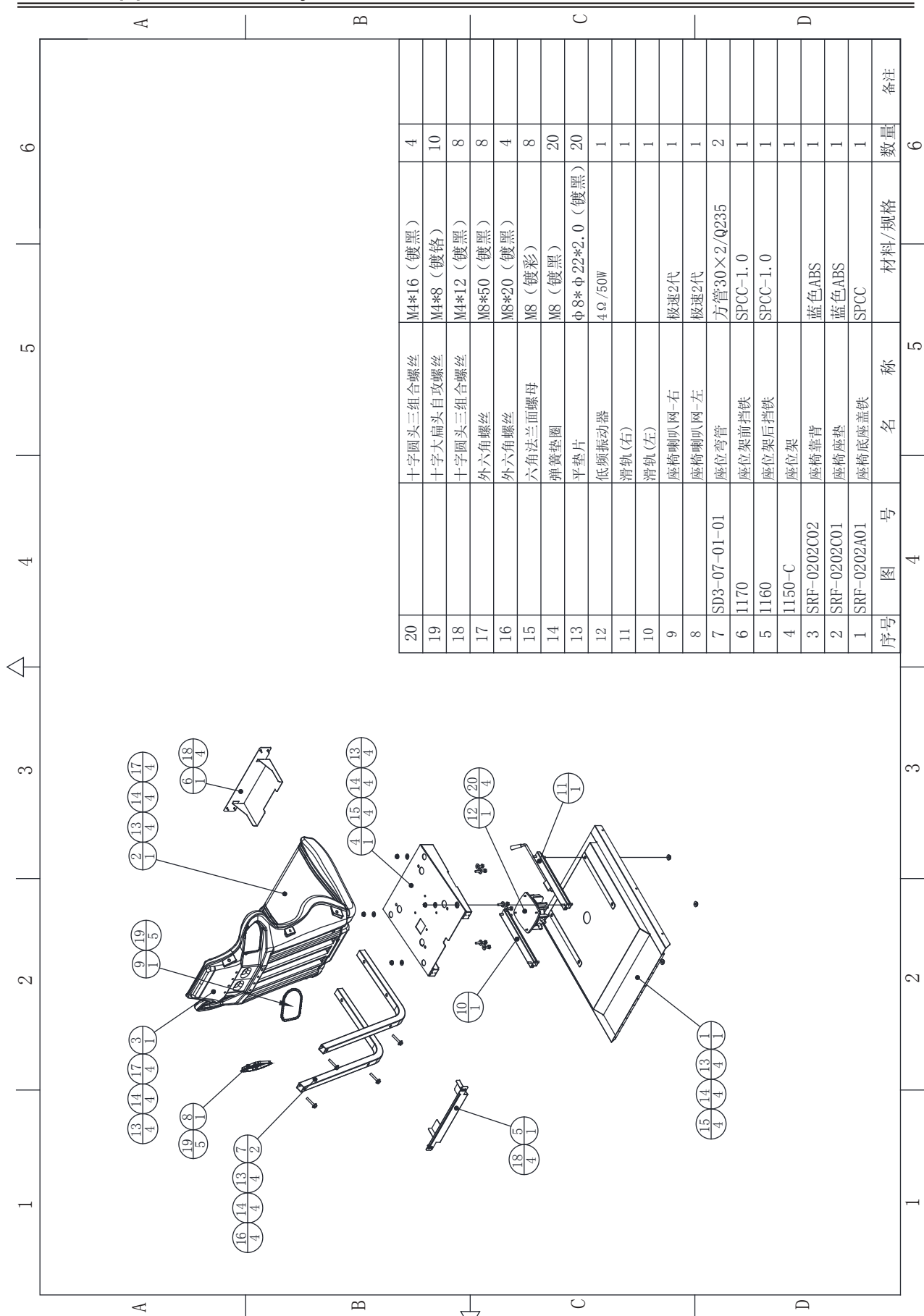

6.3.3 Mainframe assembly

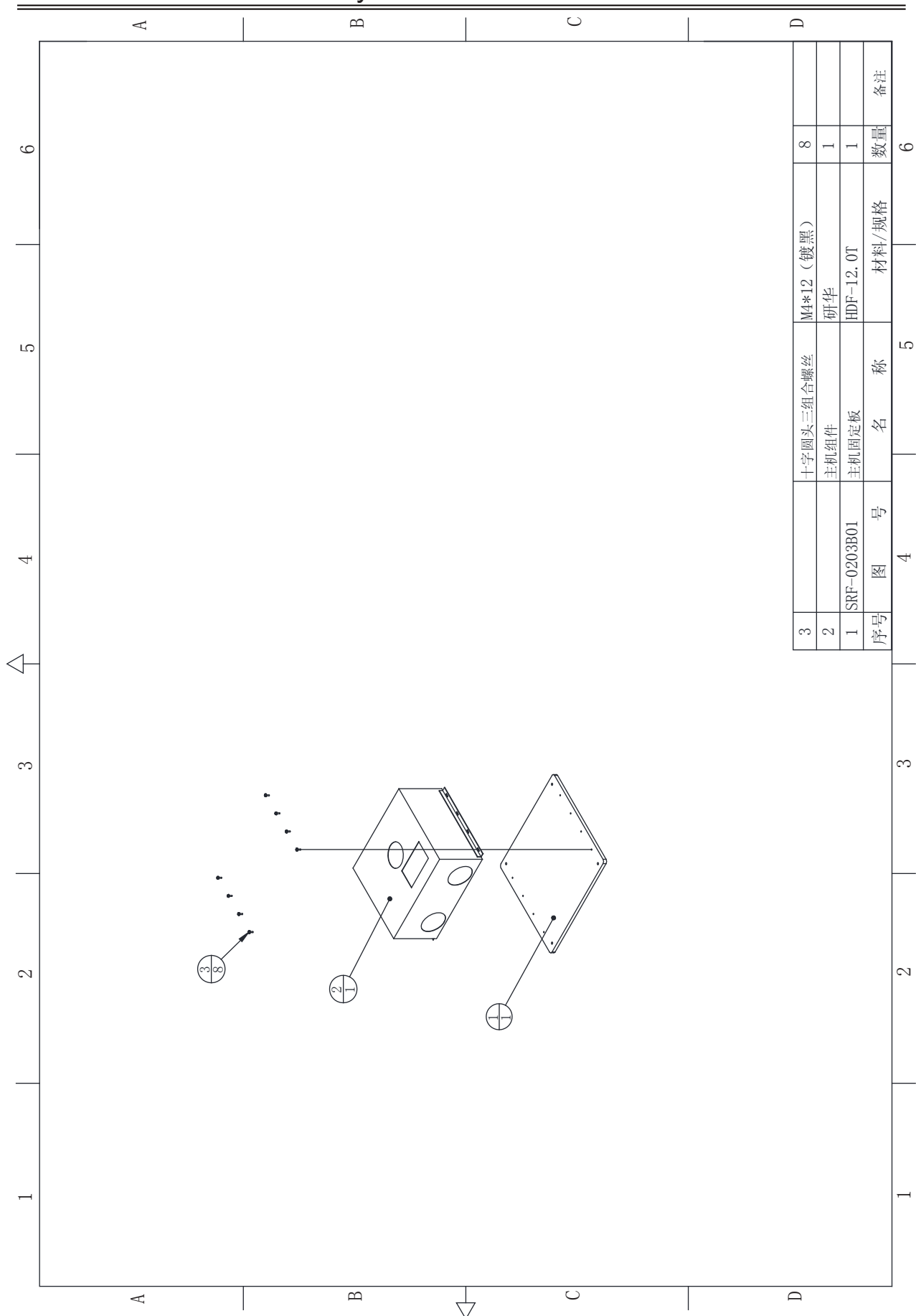

6.3.4 Backrest horn assembly

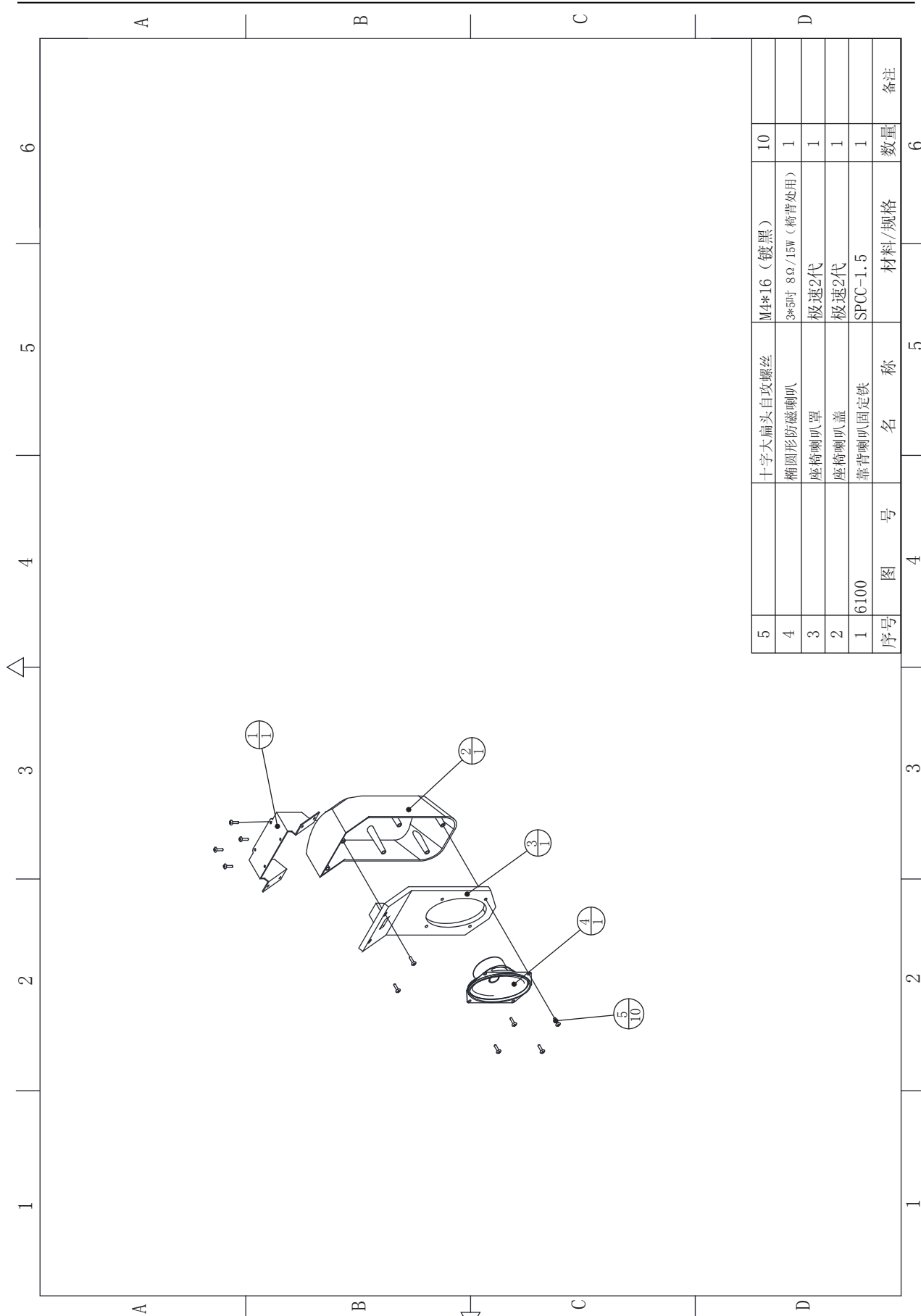

序号	图号	名称	材料/规格	数量	备注
5		十字大扁头自攻螺丝	M4*16 (镀黑)	10	
4		椭圆形防磁喇叭	3*5吋 8Ω/15W (椅背处用)	1	
3		座椅喇叭罩	极速2代	1	
2		座椅喇叭盖	极速2代	1	
1	6100	靠背喇叭固定铁	SPCC-1.5	1	

6.4 Plastic console assembly

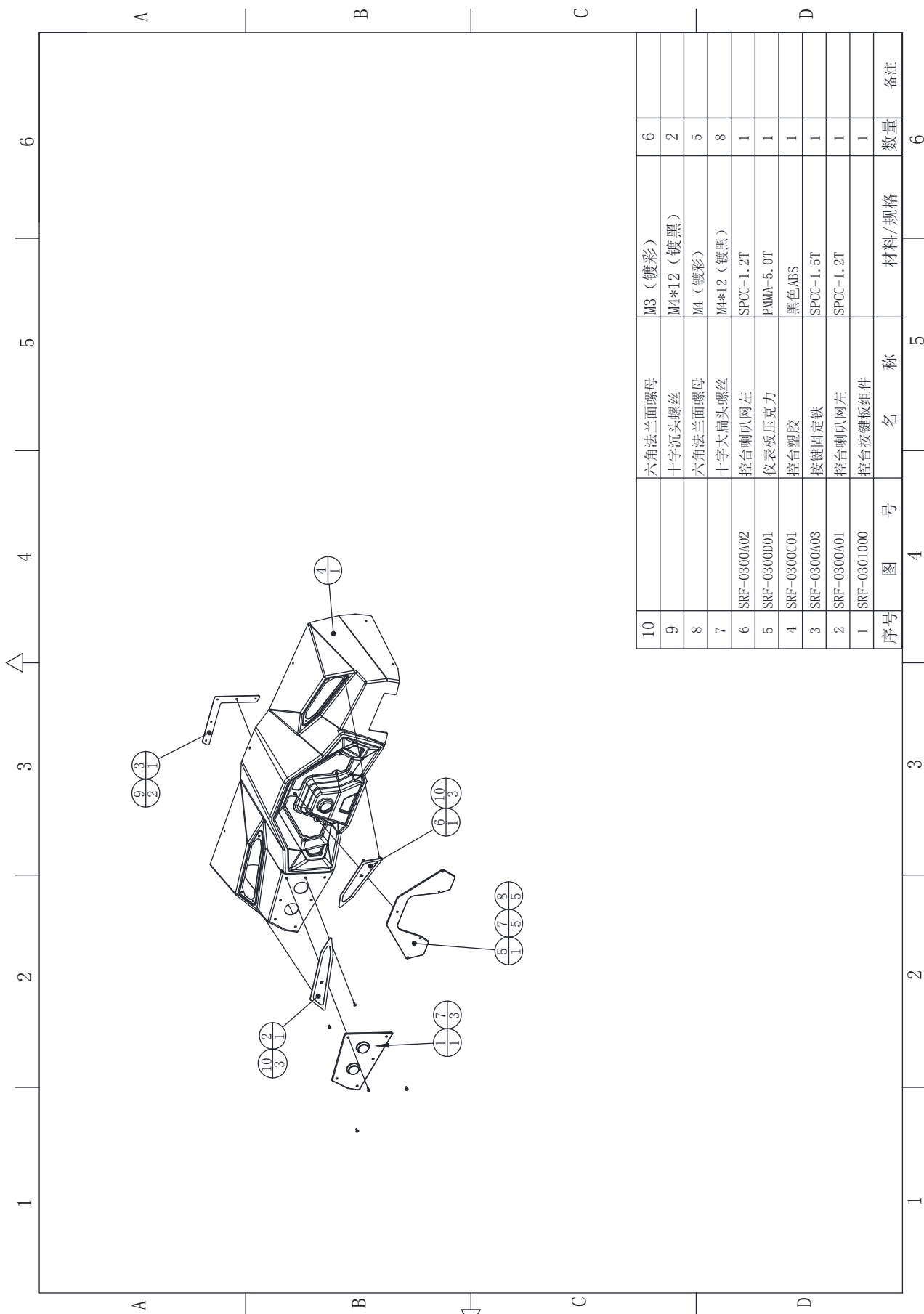

6.4.1 Console keyboard assembly

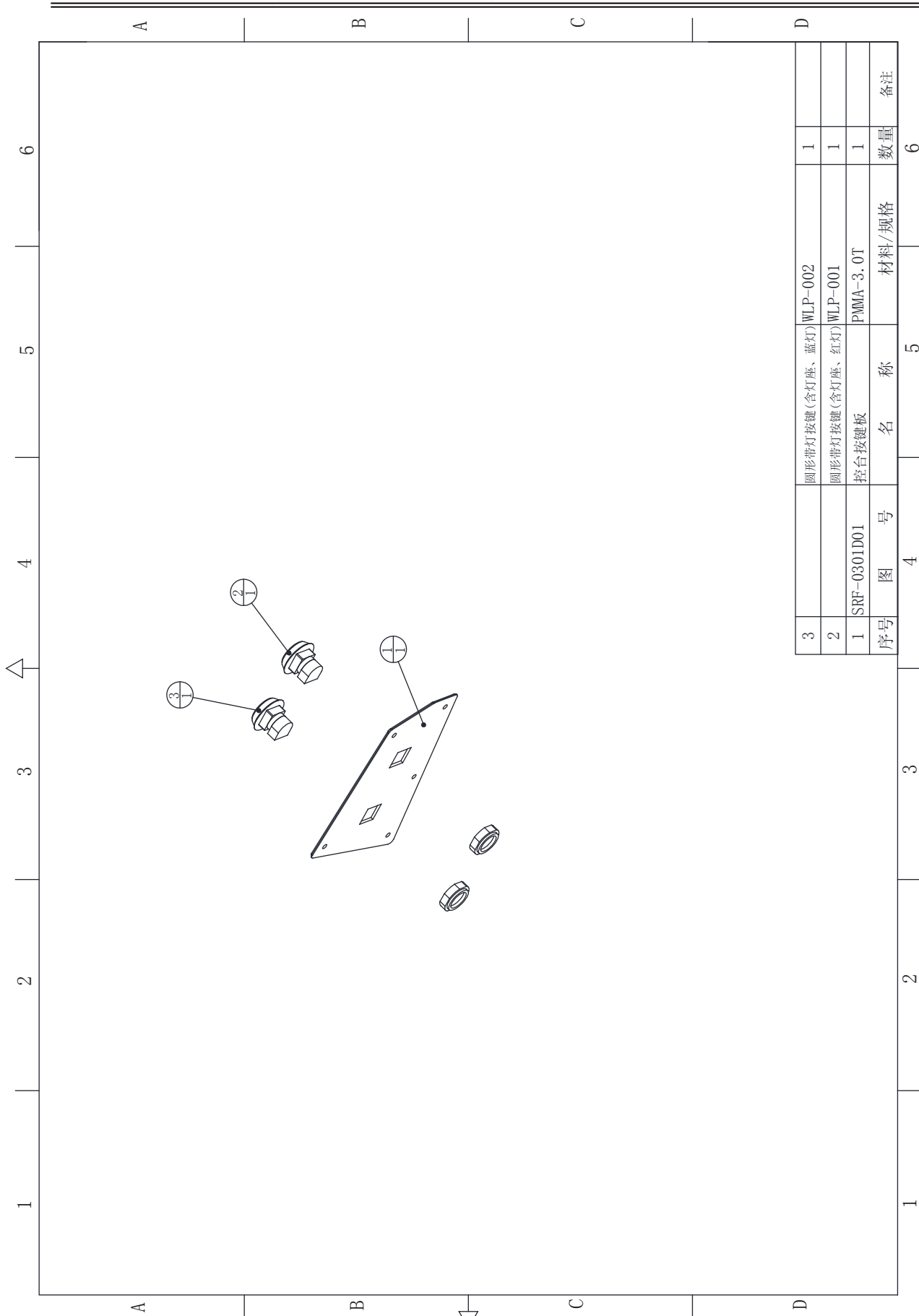

3	圆形带灯按键(含灯座、蓝灯)	WLP-002	1	
2	圆形带灯按键(含灯座、红灯)	WLP-001	1	
1	SRF-0301D01 控台按键板	PMMA-3.0T	1	
序号	图号	名称	数量	备注

6.5 LCD assembly

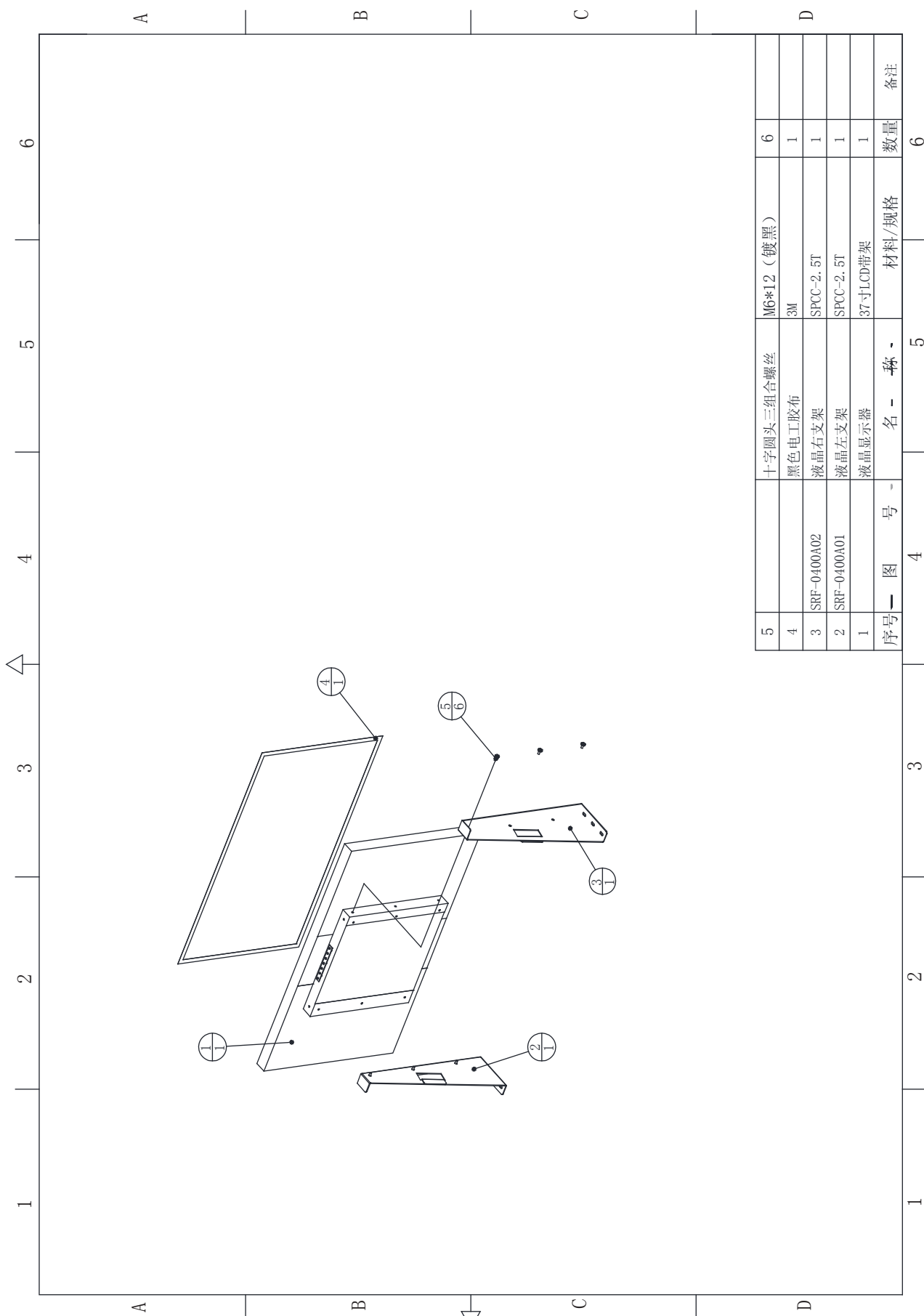

5		十字圆头三组合螺丝	M6*12 (镀黑)	6	
4		黑色电工胶布	3M	1	
3	SRF-0400A02	液晶右支架	SPCC-2.5T	1	
2	SRF-0400A01	液晶左支架	SPCC-2.5T	1	
1		液晶显示器	37寸LCD带架	1	
序号	图号	名称	材料/规格	数量	备注

6.6 LCD glass assembly

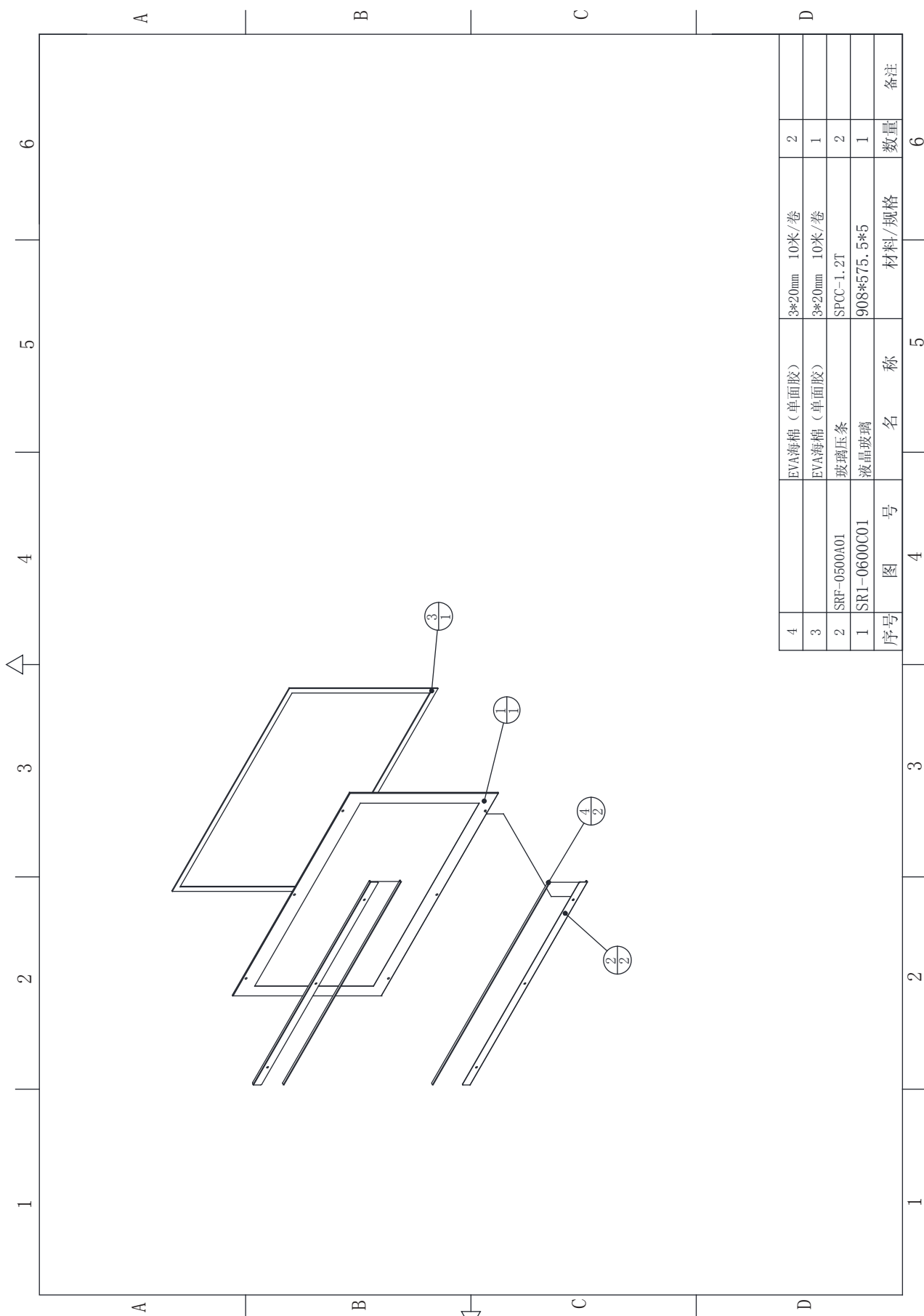

4	EVA海棉 (单面胶)	3*20mm 10米/卷	2	
3	EVA海棉 (单面胶)	3*20mm 10米/卷	1	
2	SRF-0500A01 玻璃压条	SPCC-1.2T	2	
1	SR1-0600C01 液晶玻璃	908*575.5*5	1	
序号	图号	名称	材料/规格	数量
	4	5	6	备注

6.7 Pick-up head assembly

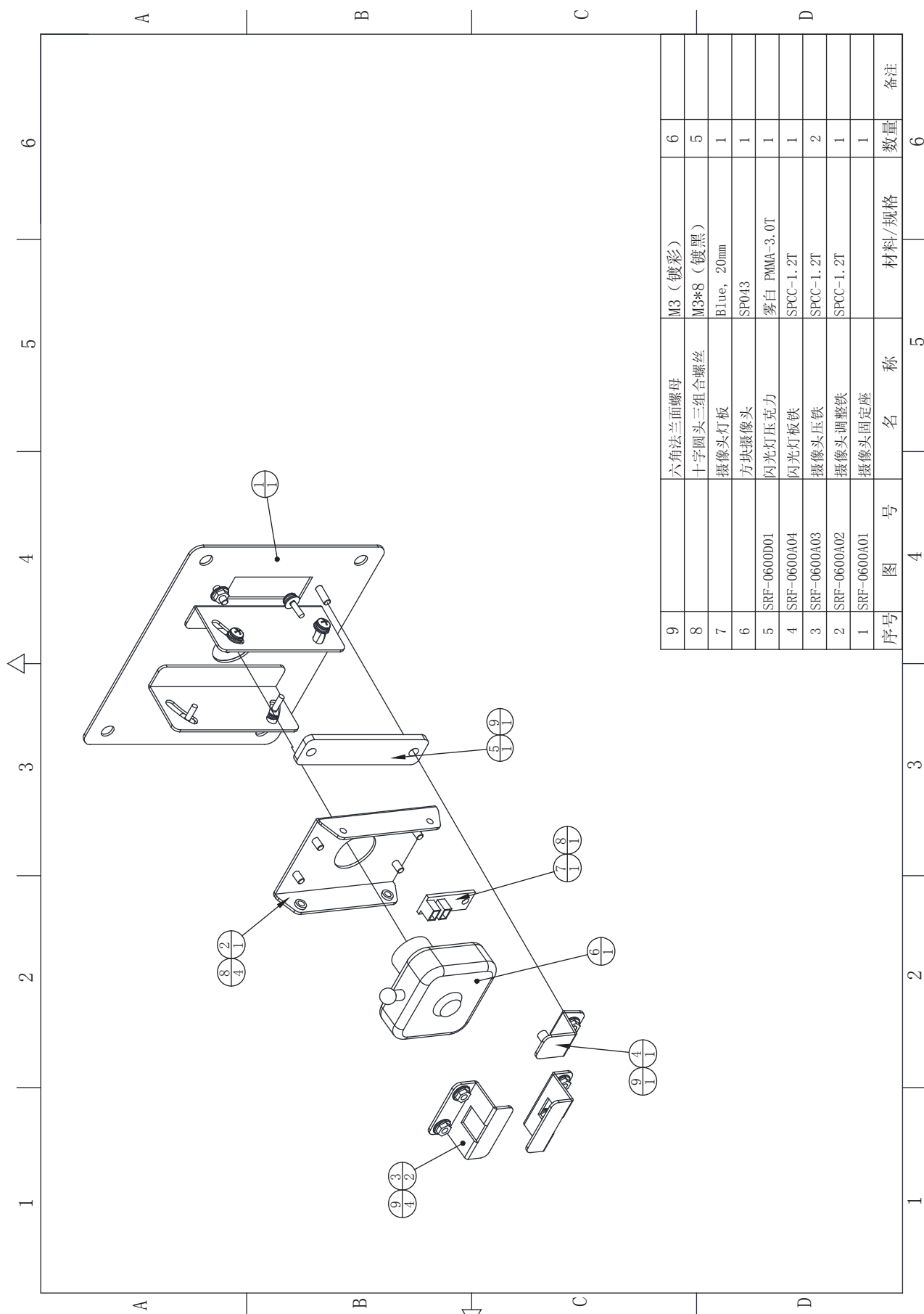

序号	图号	名称	材料/规格	数量	备注
9		六角法兰面螺母	M3 (镀彩)	6	
8		十字圆头三组合螺丝	M3*8 (镀黑)	5	
7		摄像头灯板	Blue, 20mm	1	
6		方块摄像头	SF043	1	
5		闪光灯压克力	雾白 PMMA-3.0T	1	
4		闪光灯板铁	SPCC-1.2T	1	
3		摄像头压铁	SPCC-1.2T	2	
2		摄像头调整铁	SPCC-1.2T	1	
1		摄像头固定座		1	

6.8 Billboard Assembly

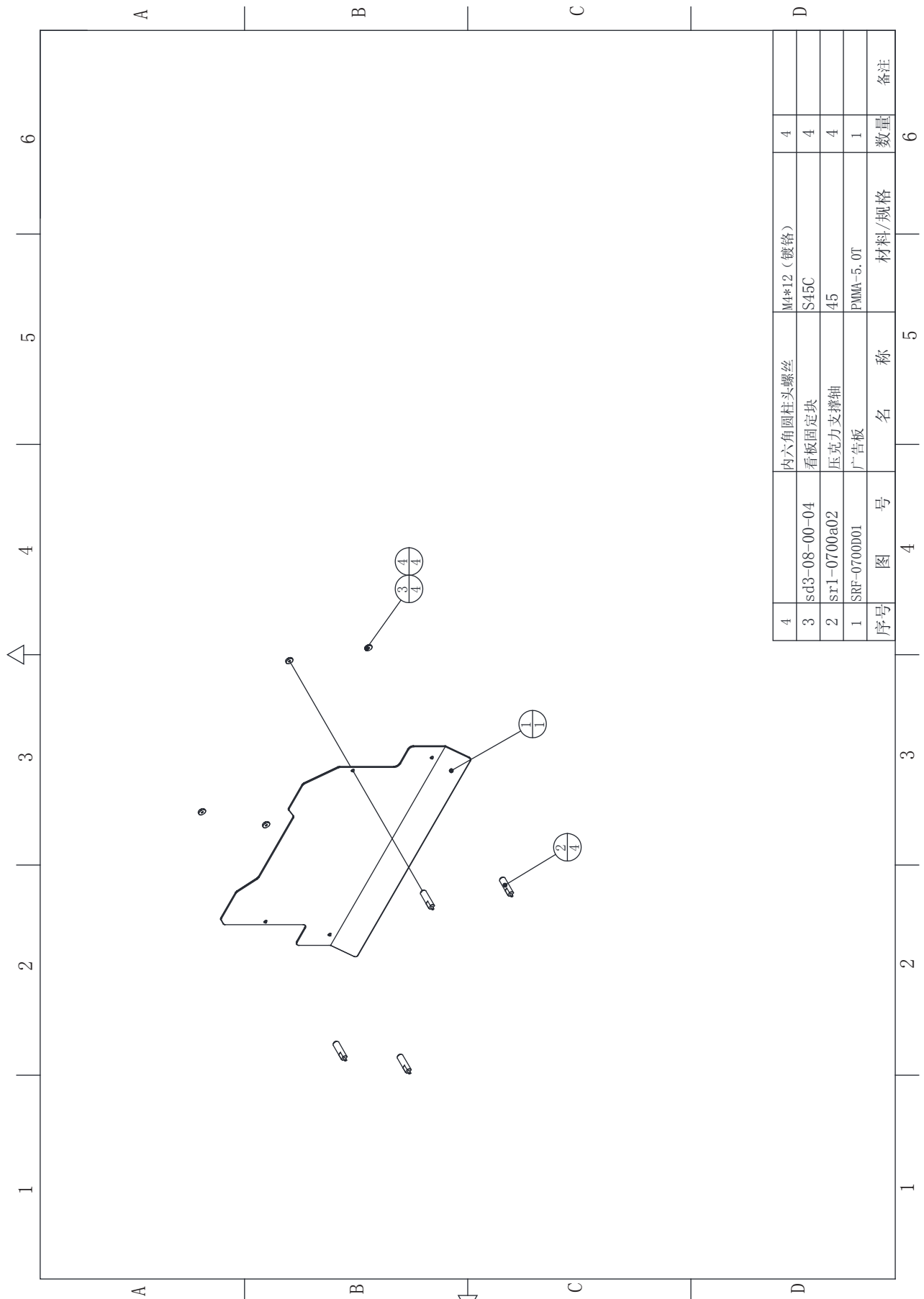

序号	图号	名称	材料/规格	数量	备注
4		内六角圆柱头螺丝	M4*12 (镀锌)	4	
3	sd3-08-00-04	看板固定块	S45C	4	
2	sr1-0700a02	亚克力支撑轴	45	4	
1	SRF-0700D01	广告板	PMMA-5.0T	1	

6.9 Right side light assembly

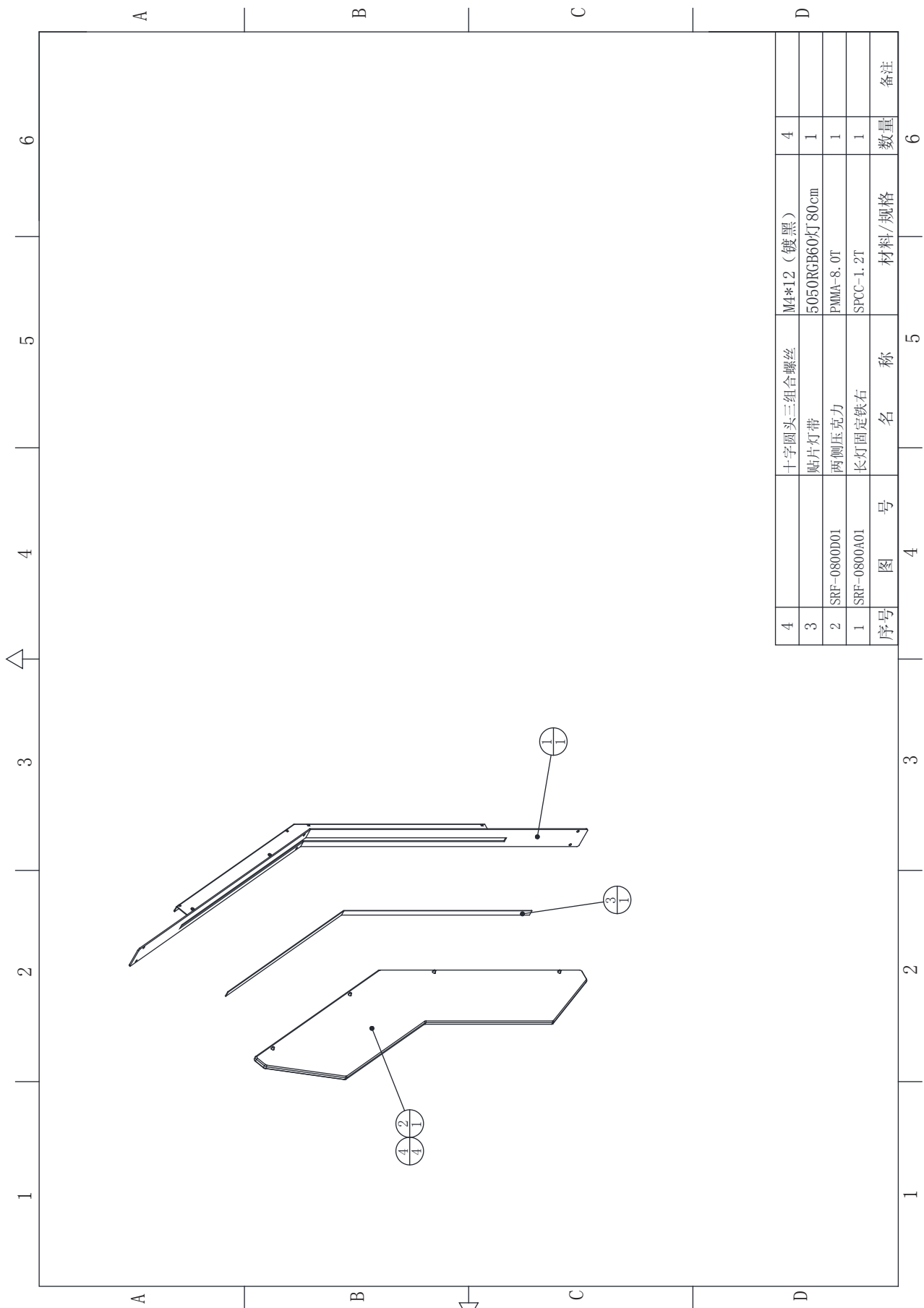

6.10 Left side light assembly

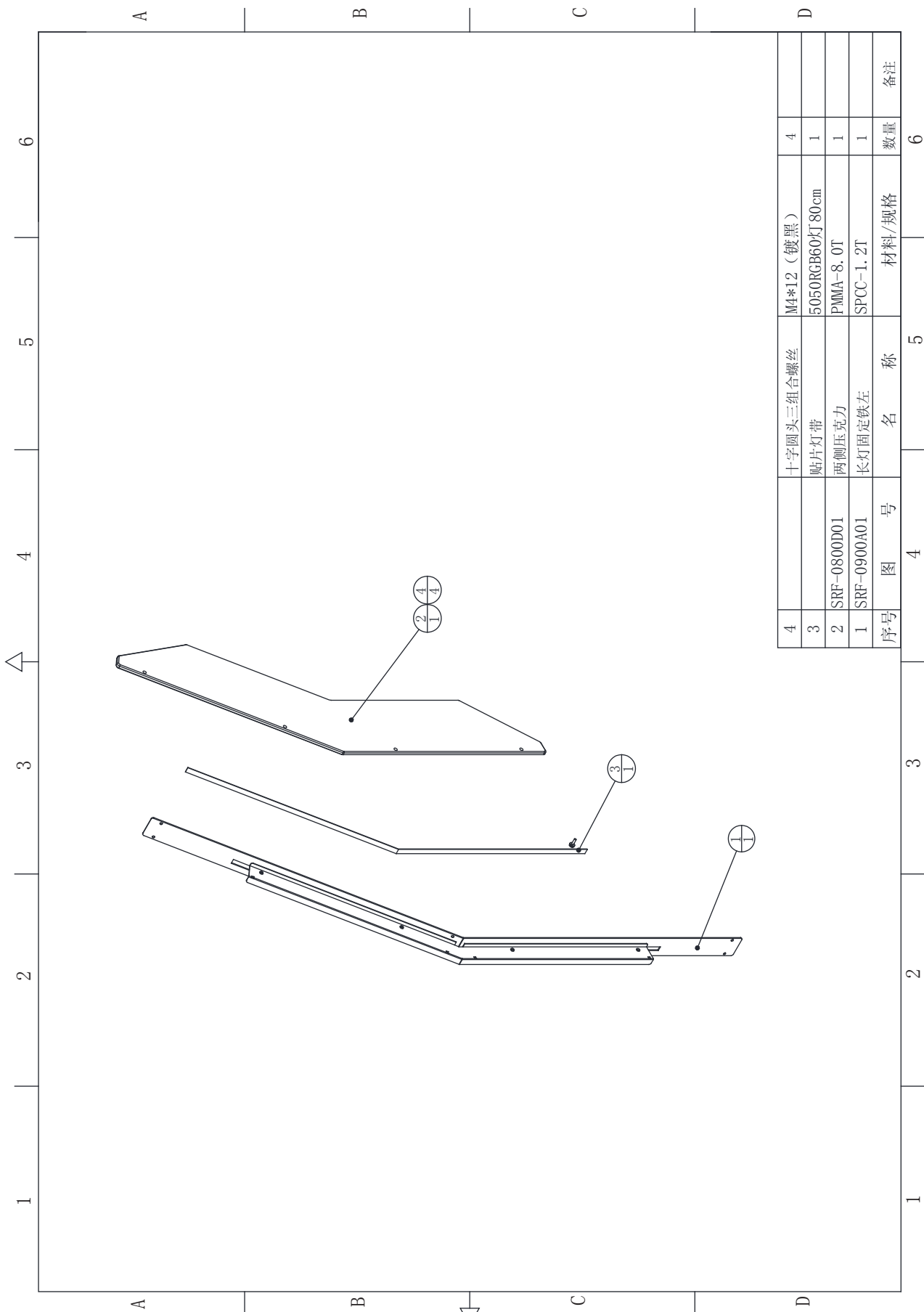

4	十字圆头三组合螺丝	M4*12 (镀黑)	4		
3	贴片灯带	5050RGB60灯80cm	1		
2	SRF-0800D01	两侧亚克力	1		
1	SRF-0900A01	长灯固定铁左	1		
序号	图号	名称	材料/规格	数量	备注
	4	5		6	

6.11 Push rod assembly

序号	图号	名称	材料/规格	数量	备注
23		弹簧垫圈	M6 (镀黑)	2	
22		内六角圆柱头螺丝	M5*16 (镀黑)	2	
21		十字圆头三组合螺丝	M5*12 (镀黑)	4	
20		六角法兰面螺母	M5 (镀彩)	8	
19		十字圆头三组合螺丝	M4*8 (镀黑)	7	
18		平垫片	Φ4*Φ16*1.0 (镀黑)	2	
17		平垫片	Φ4*Φ10*1.0 (镀黑)	1	
16		轴用弹性挡圈	GB/T 894.1-1986 10	2	
15		开口挡圈 (E型扣)	M6 (镀黑)	8	
14	SRF-1000C04	凸轮	白色POM	1	
13	SRF-1000C03	双联齿轮	白色POM	1	
12	SRF-1000C02	主齿轮	白色POM	1	
11	SRF-1000C01	限位套	优力胶	2	
10	SRF-1000A04	钢板弹簧压板	SPCC-2.0T	1	
9	SRF-1000A03	定位轴	45	4	
8	SRF-1000A02	中间轴	45	1	
7	SRF-1000A01	长弹簧轴	45	3	
6	SRF-1006000	吸铁组件		1	
5	SRF-1005000	电磁铁组件		1	
4	SRF-1004000	传动轴组件		1	
3	SRF-1003000	右侧板组件		1	
2	SRF-1002000	左侧板组件		1	
1	SRF-1001000	手把组件		1	

6.11.1 Handle assembly

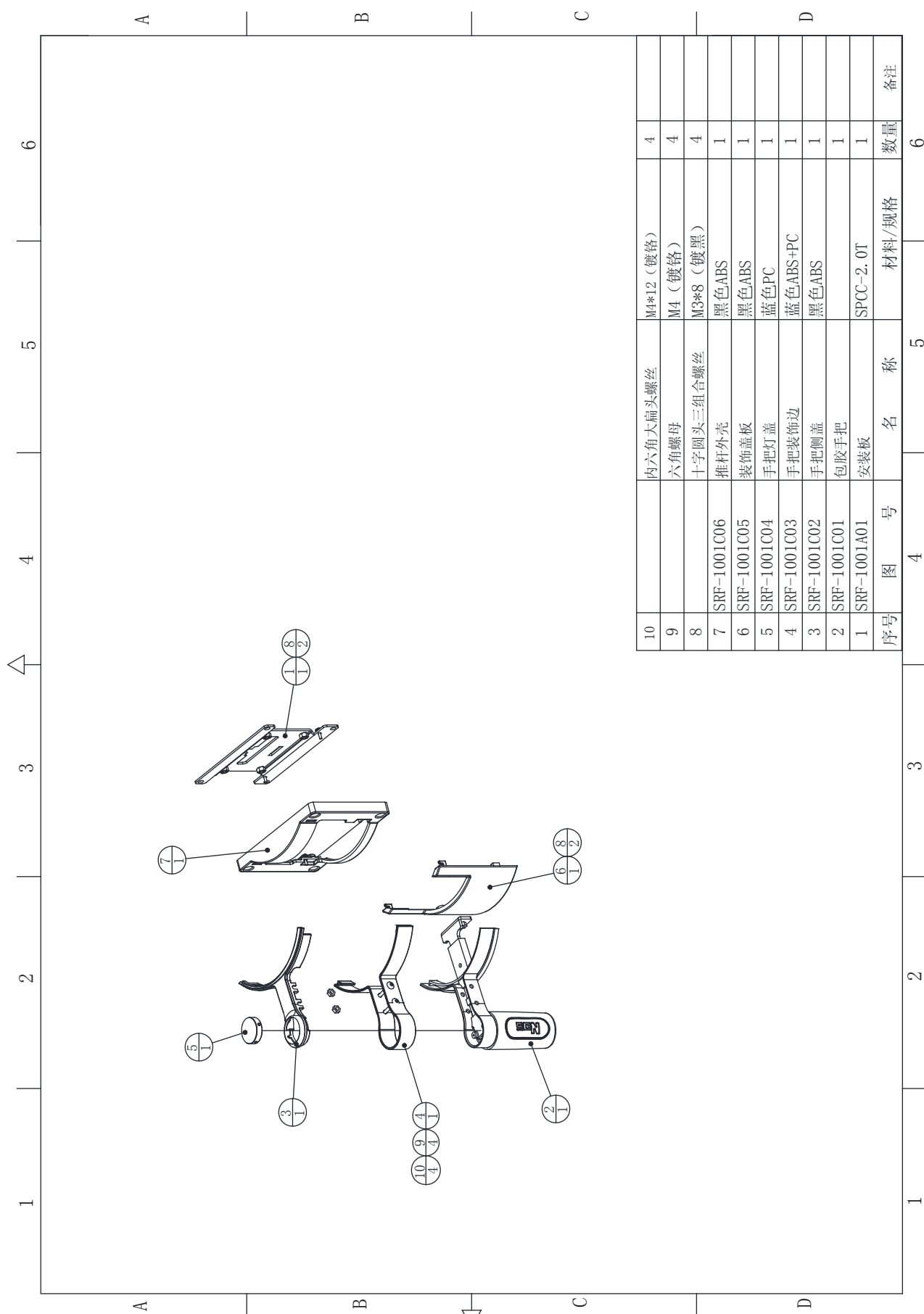

6.11.2 Left side plate assembly

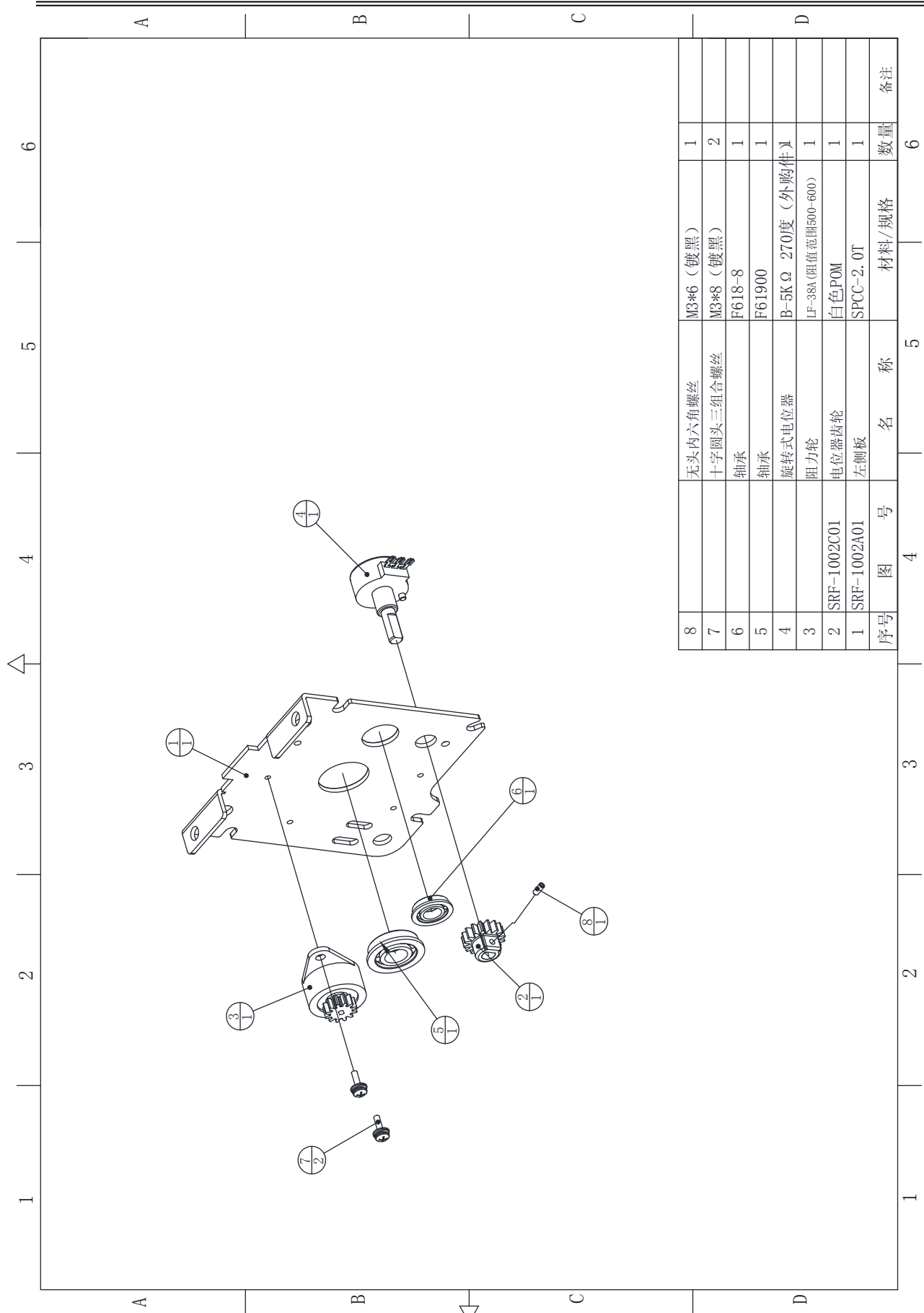

8	无头内六角螺丝	M3*6 (镀黑)	1	
7	十字圆头三组合螺丝	M3*8 (镀黑)	2	
6	轴承	F618-8	1	
5	轴承	F61900	1	
4	旋转式电位器	B-5K Ω 270度 (外购件)	1	
3	阻力轮	LF-38A (阻值范围500-600)	1	
2	SRF-1002C01 电位器齿轮	白色POM	1	
1	SRF-1002A01 左侧板	SPCC-2.0T	1	
序号	图号	名称	材料/规格	数量
	4	5		6
				备注

6.11.3 Right side plate assembly

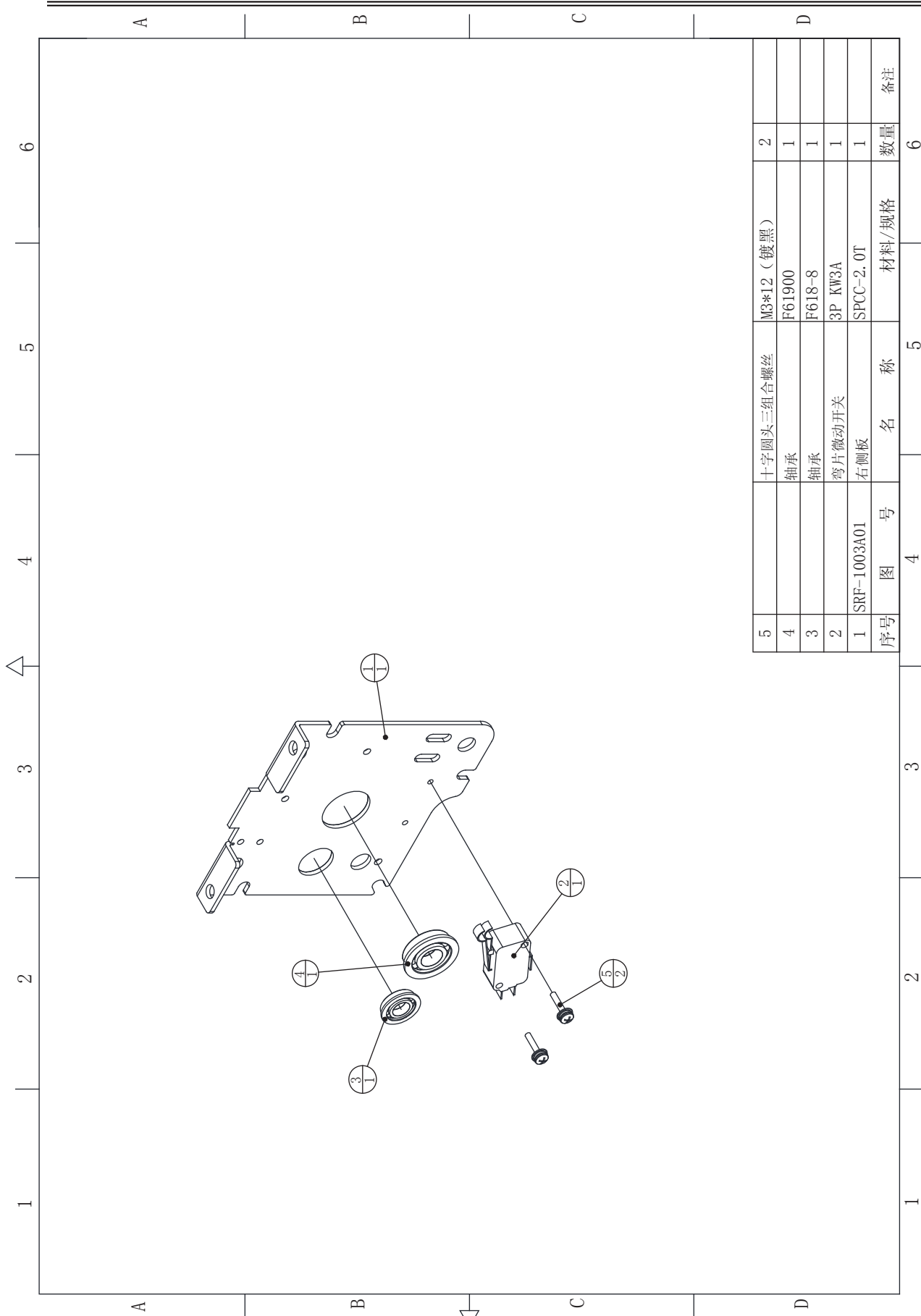

序号	图号	名称	材料/规格	数量	备注
5		十字圆头三组合螺丝	M3*12 (镀黑)	2	
4		轴承	F61900	1	
3		轴承	F618-8	1	
2		弯片微动开关	3P KW3A	1	
1	SRF-1003A01	右侧板	SPCC-2.0T	1	

6.11.4 Drive shaft assembly

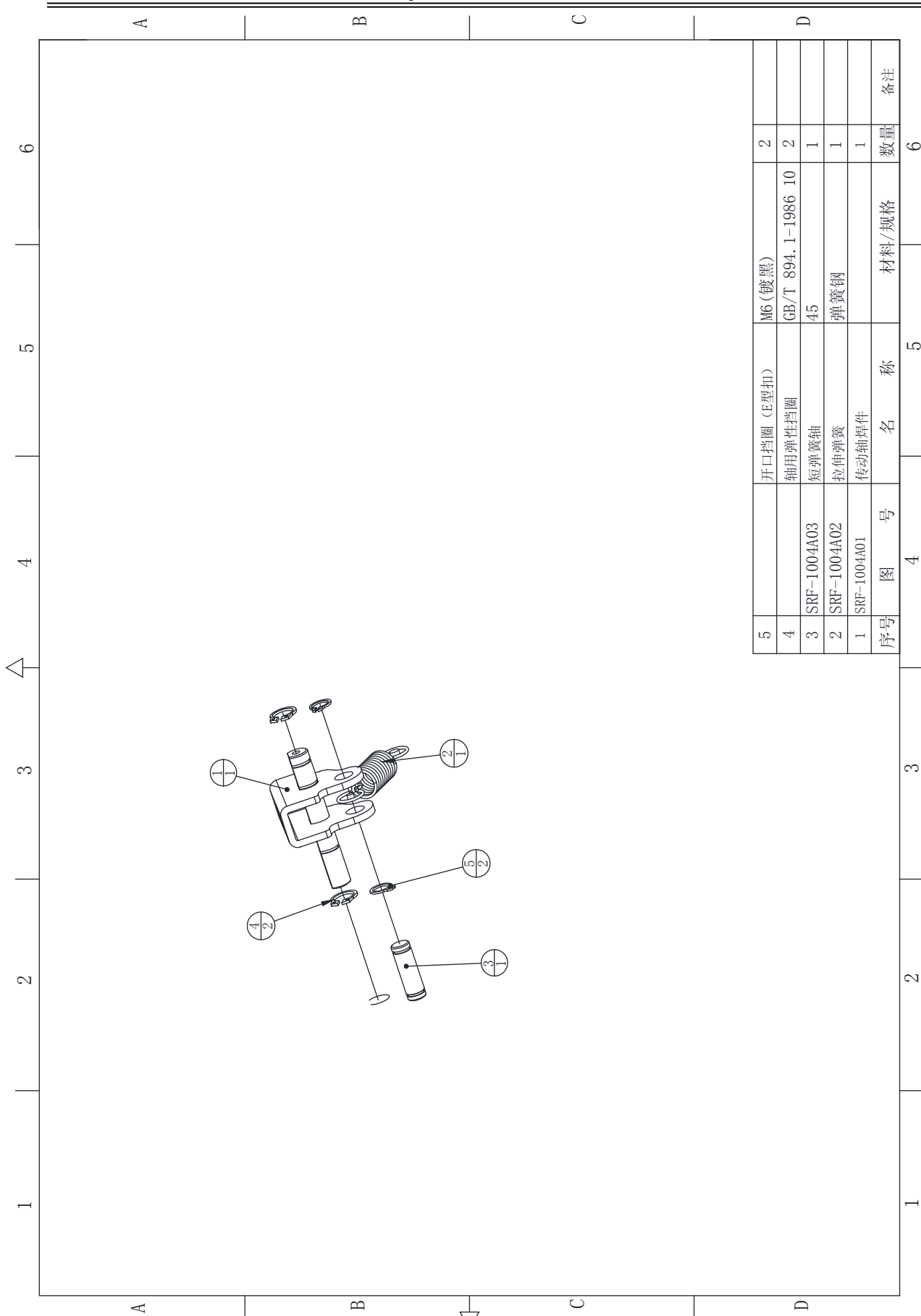

6.11.5 Electromagnet assembly

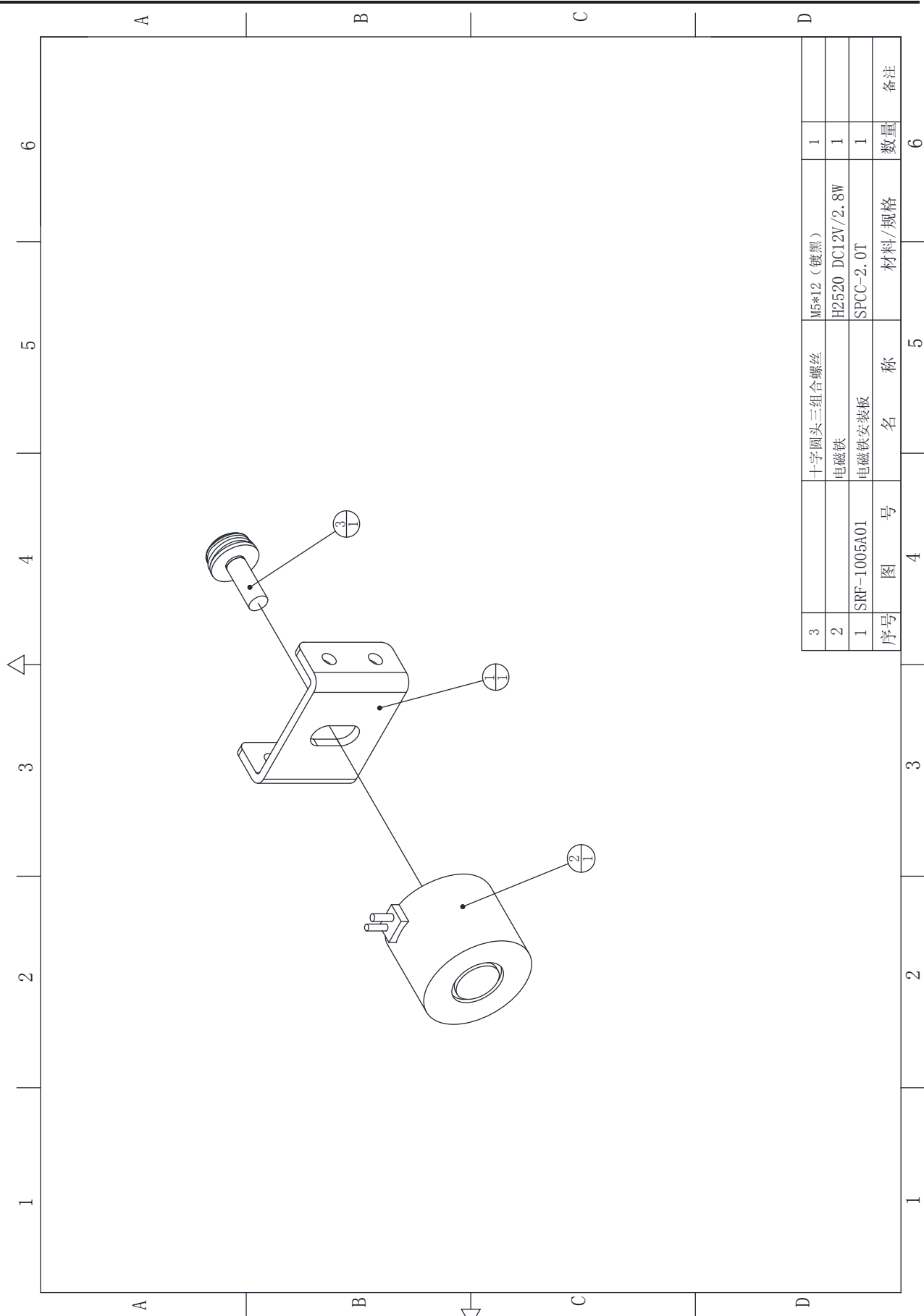

6.11.6 Suction block assembly

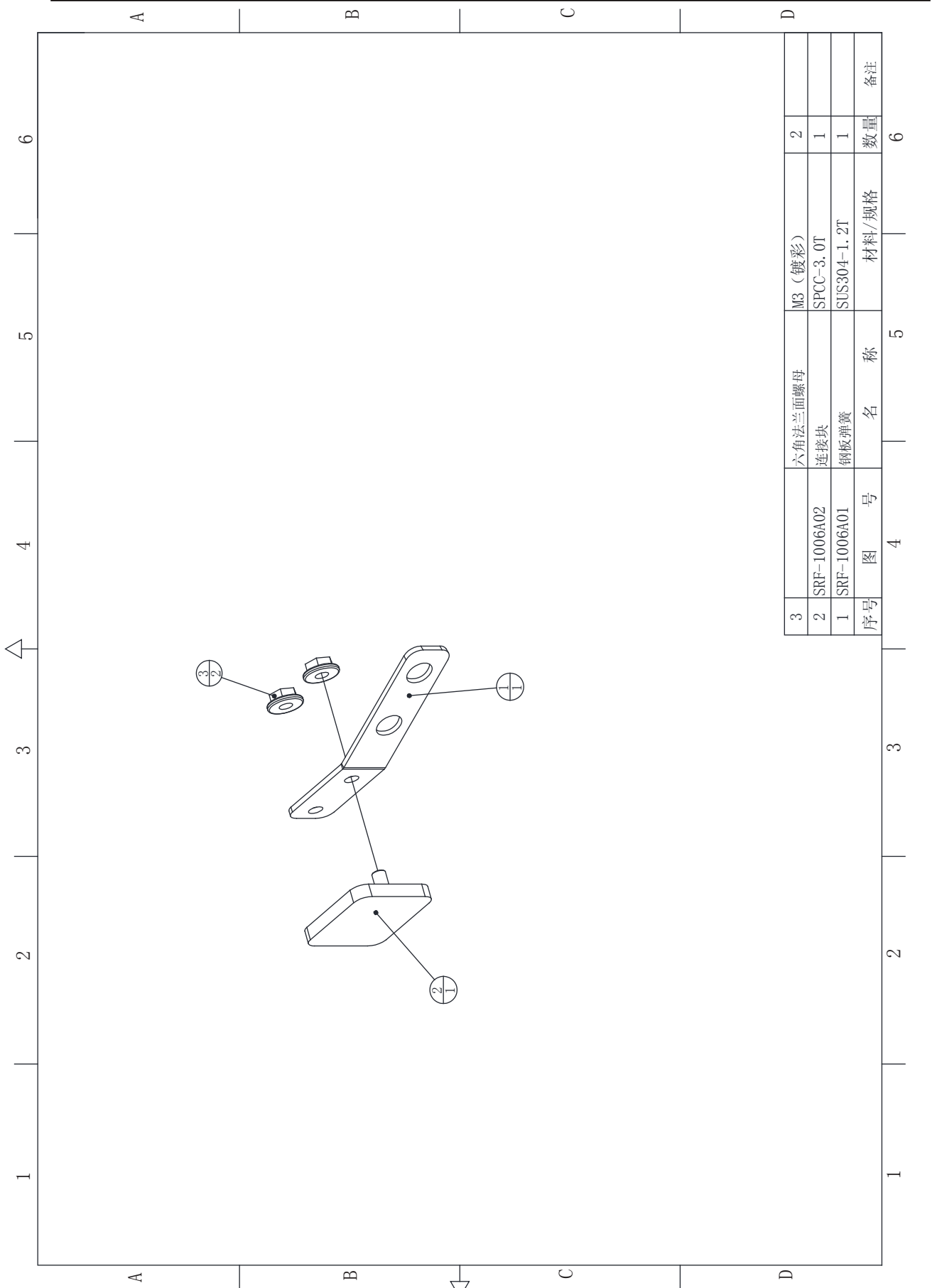

3	六角法兰面螺母	M3 (镀锌)	2	
2	SRF-1006A02	连接块	1	
1	SRF-1006A01	钢板弹簧	1	
序号	图号	名称	材料/规格	数量 备注
	4	5	6	6

6.12 Coin door assembly

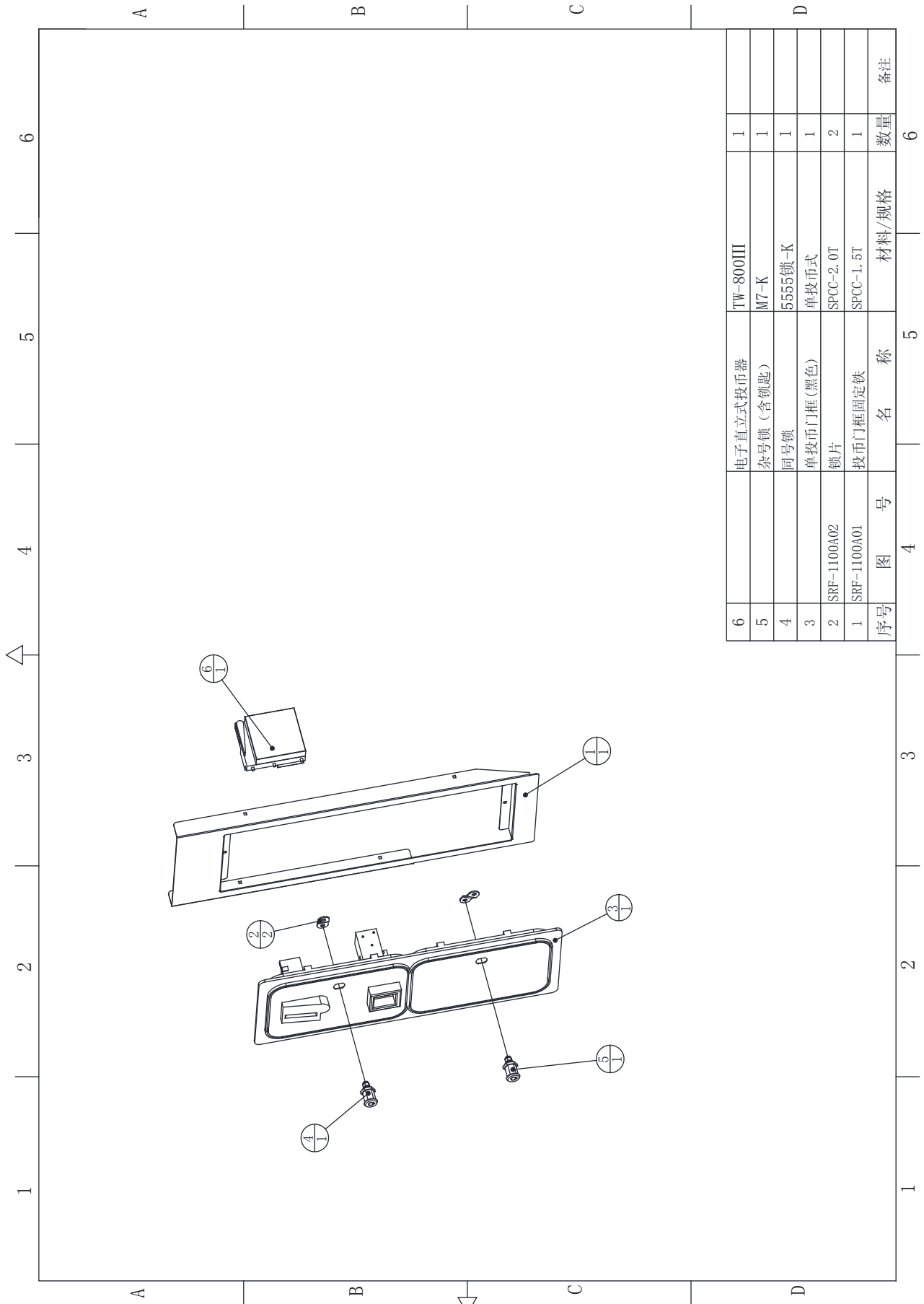

6.13 Stepping cover assembly

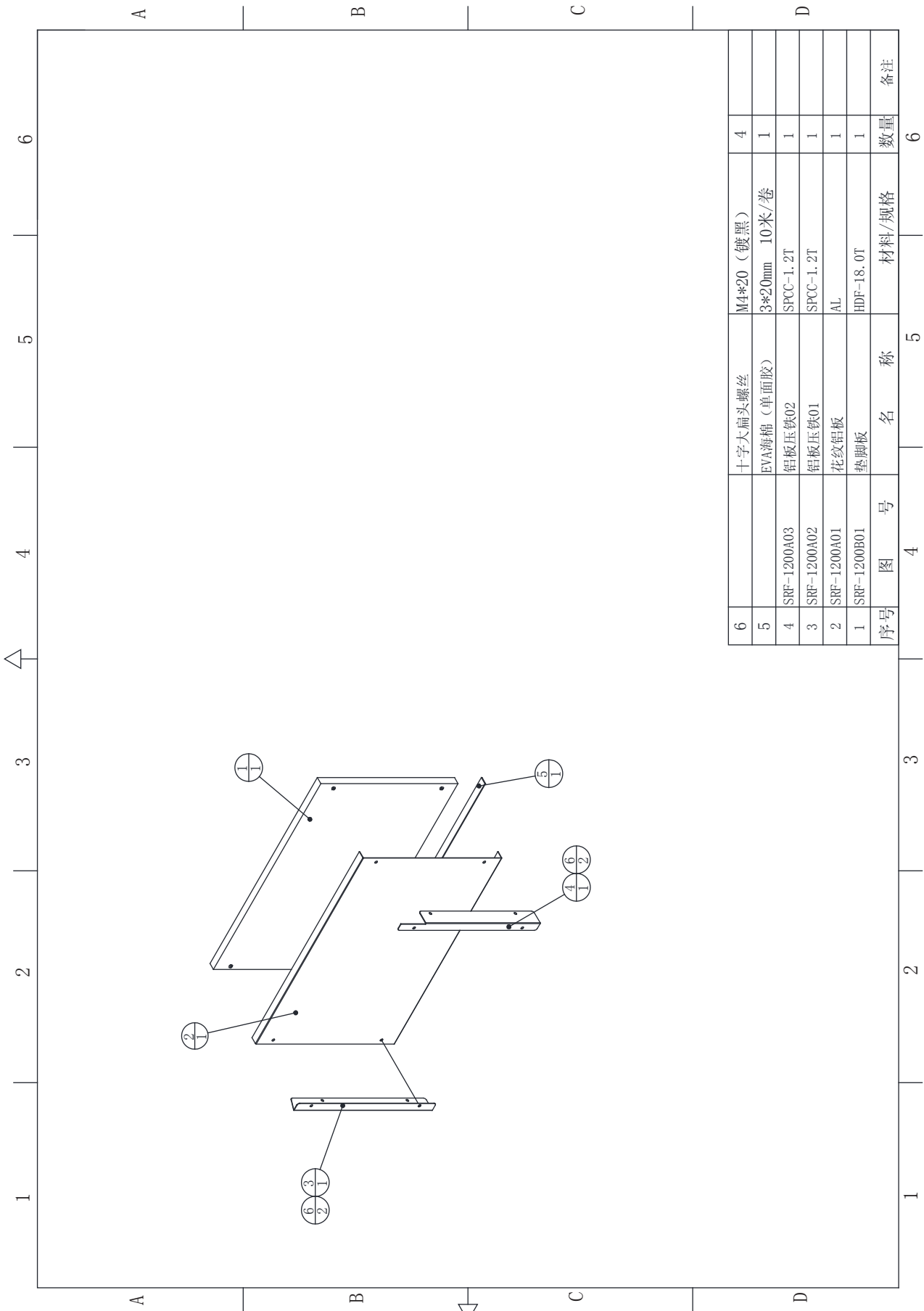

序号	图号	名称	材料/规格	数量	备注
6		十字大扁头螺丝	M4*20 (镀黑)	4	
5		EVA海棉 (单面胶)	3*20mm 10米/卷	1	
4	SRF-1200A03	铝板压铁02	SPCC-1.2T	1	
3	SRF-1200A02	铝板压铁01	SPCC-1.2T	1	
2	SRF-1200A01	花纹铝板	AL	1	
1	SRF-1200B01	垫脚板	HDF-18.0T	1	

6.14 Pedal assembly

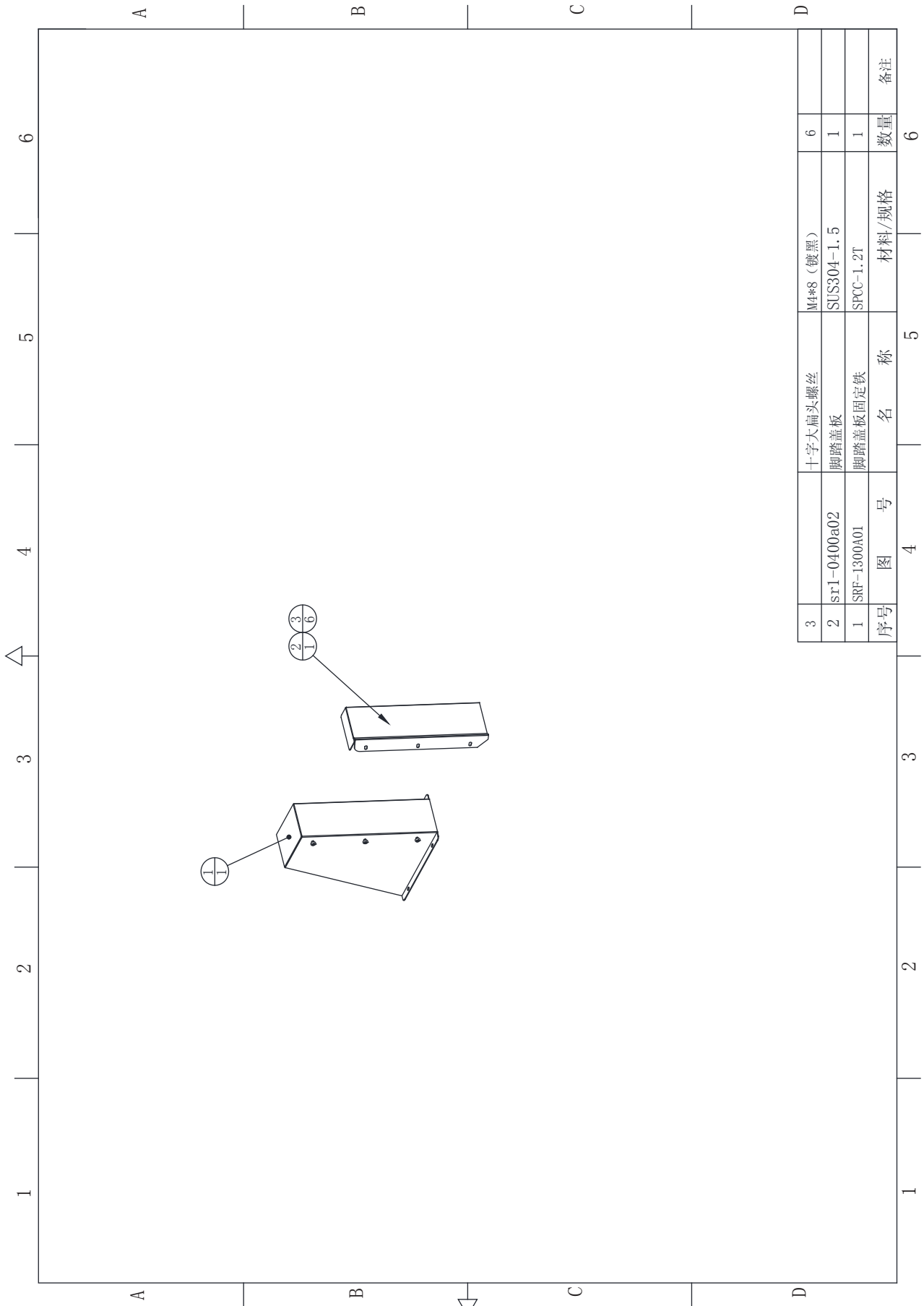

3	十字大扁头螺丝	M4*8 (镀黑)	6
2	sr1-0400a02 脚踏盖板	SUS304-1.5	1
1	SRF-1300A01 脚踏盖板固定铁	SPCC-1.2T	1
序号	图号	名称	数量
	4	材料/规格	备注
			6

6.15 Upper assembly of back door plate

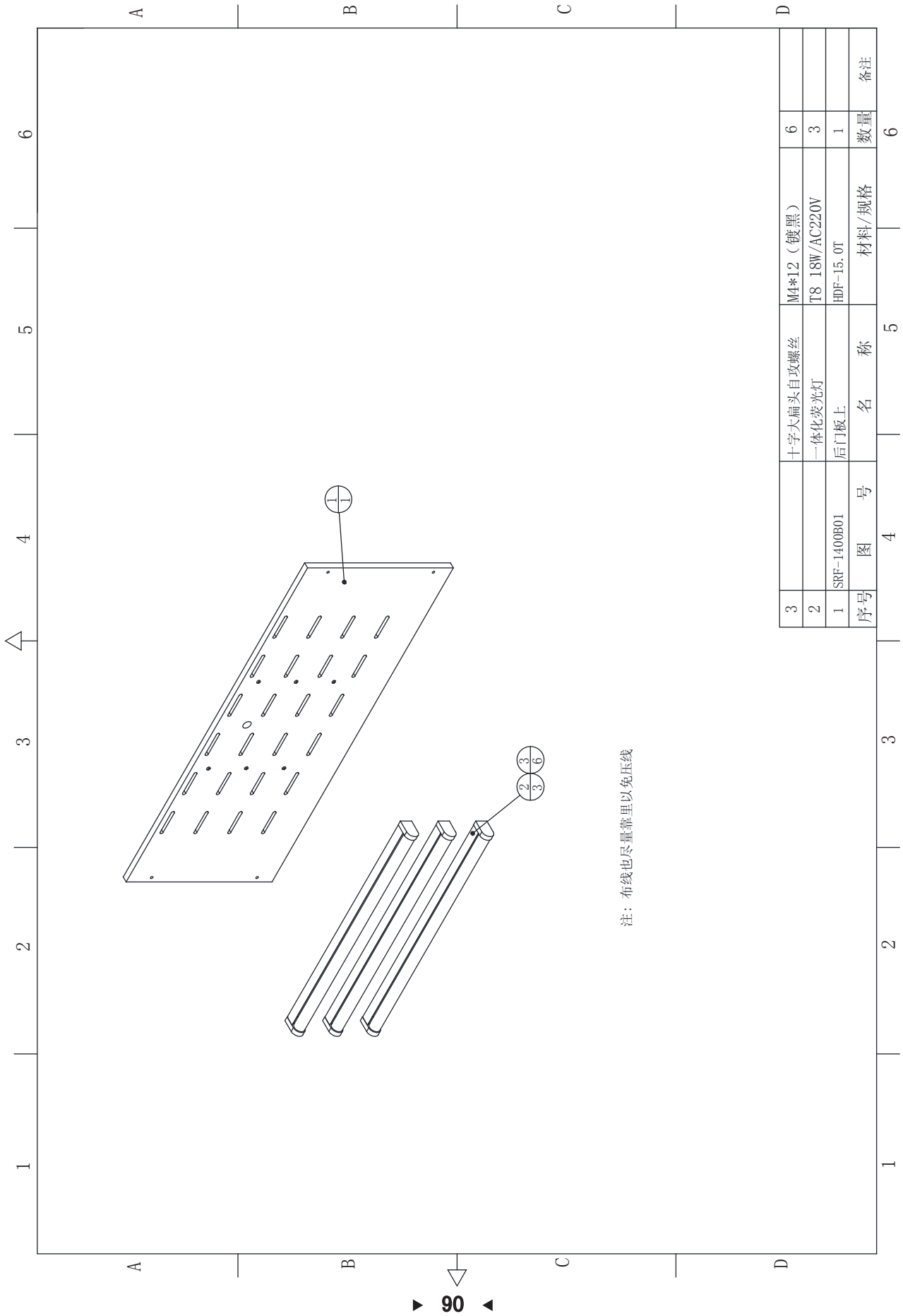

序号	图号	名称	材料/规格	数量	备注
3		十字大扁头自攻螺丝	M4*12 (镀黑)	6	
2		一体化荧光灯	T8 18W/AC220V	3	
1	SRF-1400B01	后门板上	HDF-15.0T	1	

注：布线也尽量靠里以免压线

6.16 Intermediate assembly of back door plate

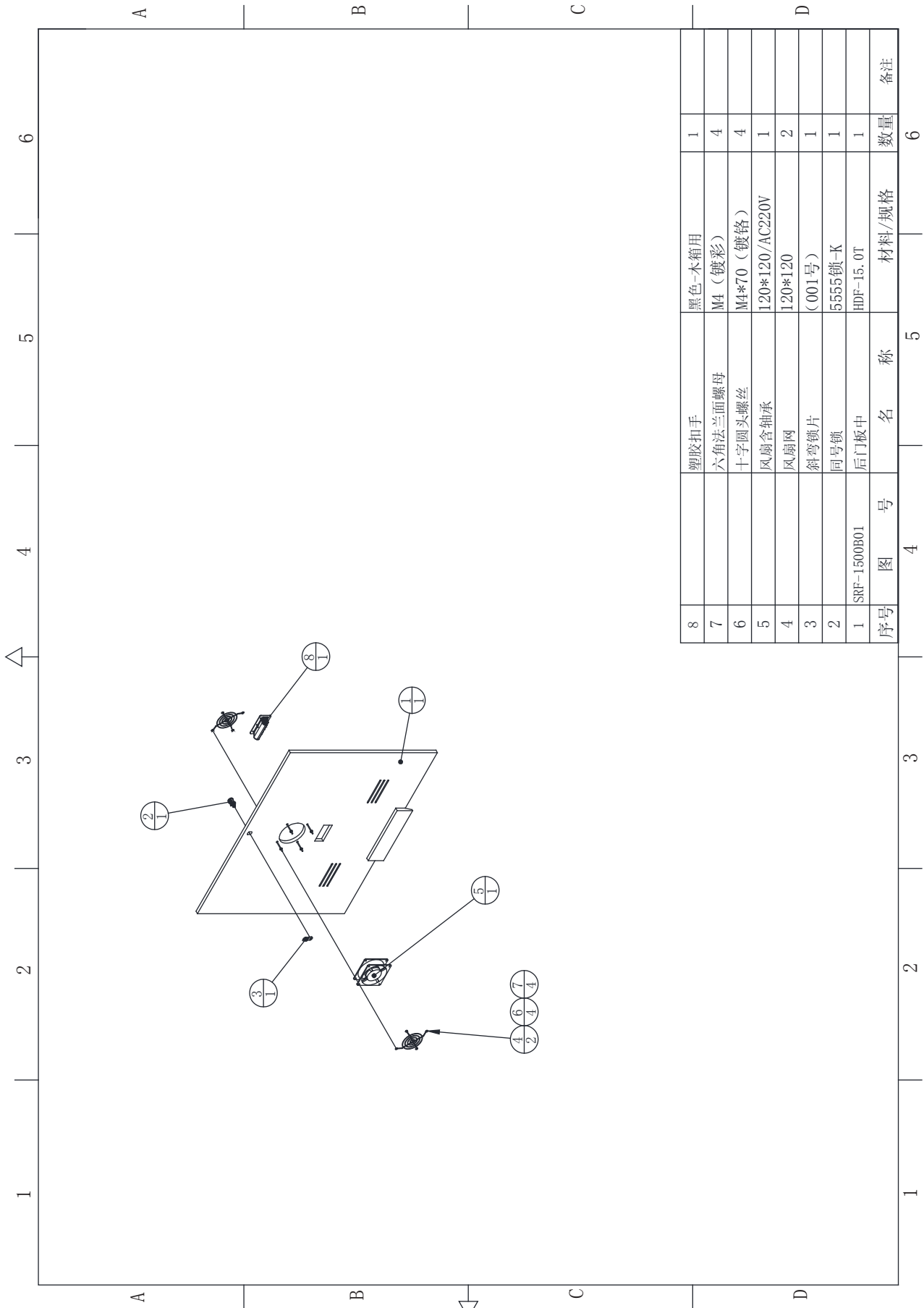

8	塑胶扣手	黑色-木箱用	1	
7	六角法兰面螺母	M4 (镀彩)	4	
6	十字圆头螺丝	M4*70 (镀铬)	4	
5	风扇含轴承	120*120/AC220V	1	
4	风扇网	120*120	2	
3	斜弯锁片	(001号)	1	
2	同号锁	5555锁-K	1	
1	SRF-1500B01 后门板中	HDF-15.0T	1	
序号	图号	名称	材料/规格	数量
	4	5	6	备注

6.17 Steering wheel assembly

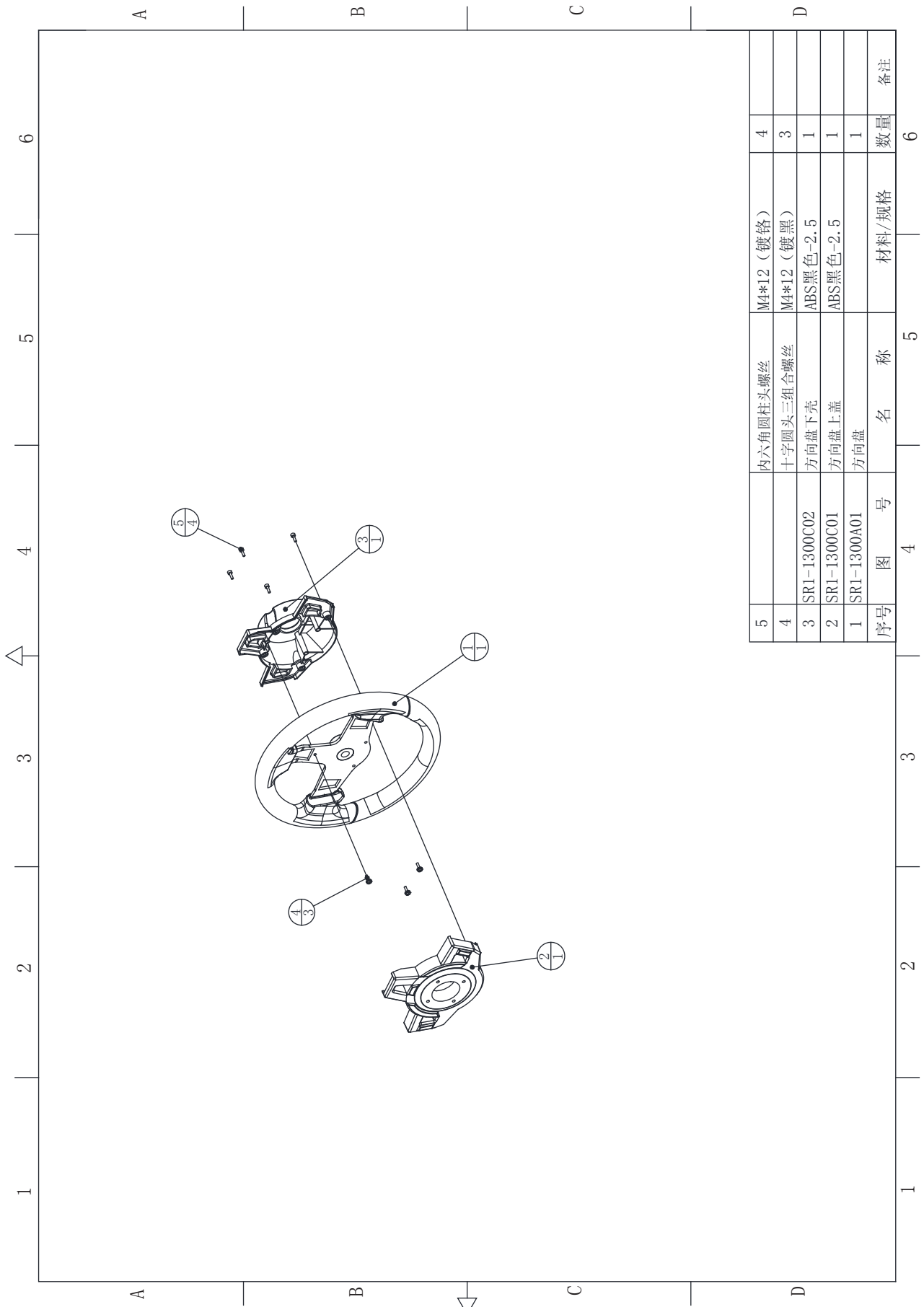



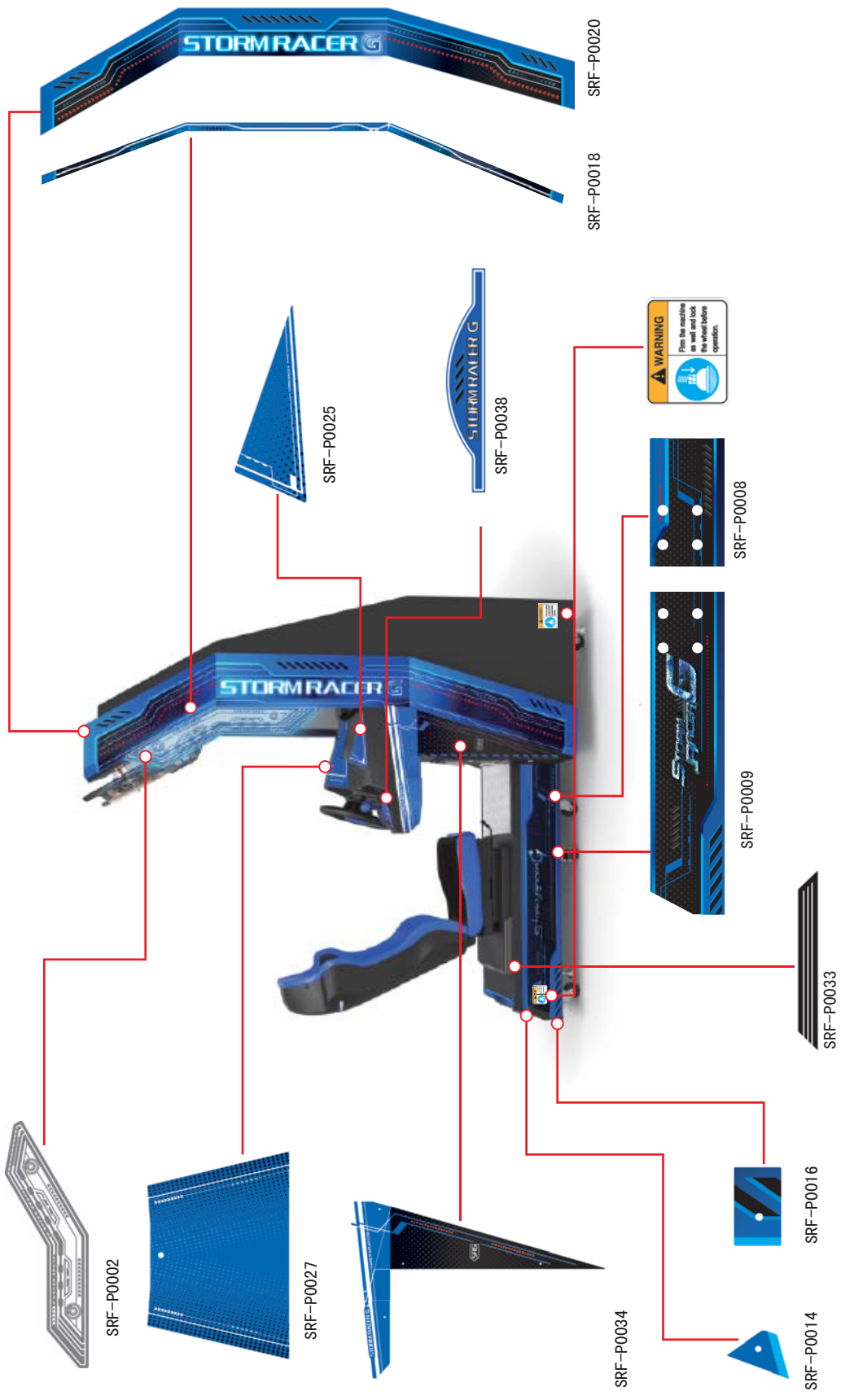

8. Wiring Diagram

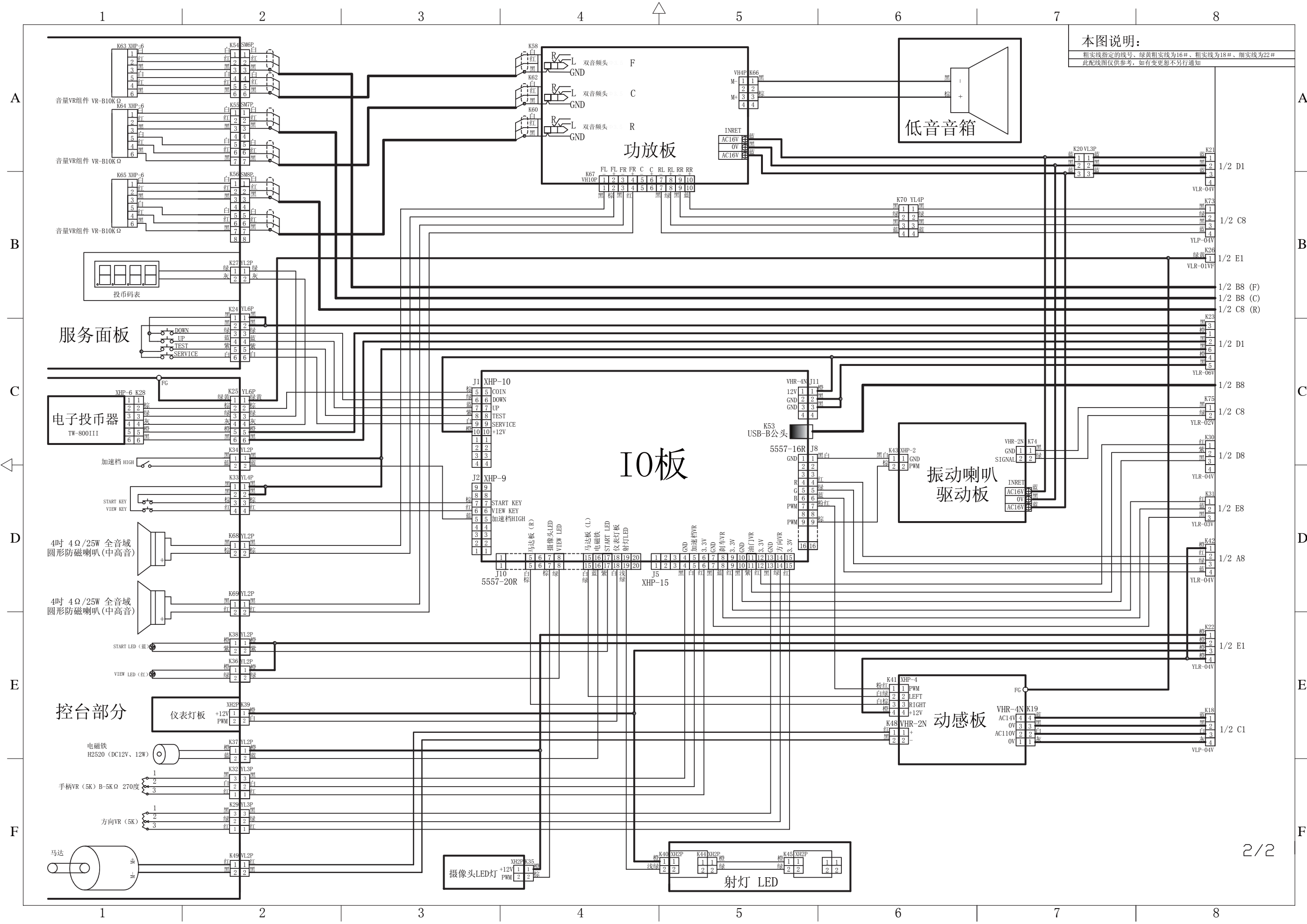

本图说明:
粗实线指定的线号、绿黄粗实线为16#、粗实线为18#、细实线为22#
此配线图仅供参考, 如有变更恕不另行通知

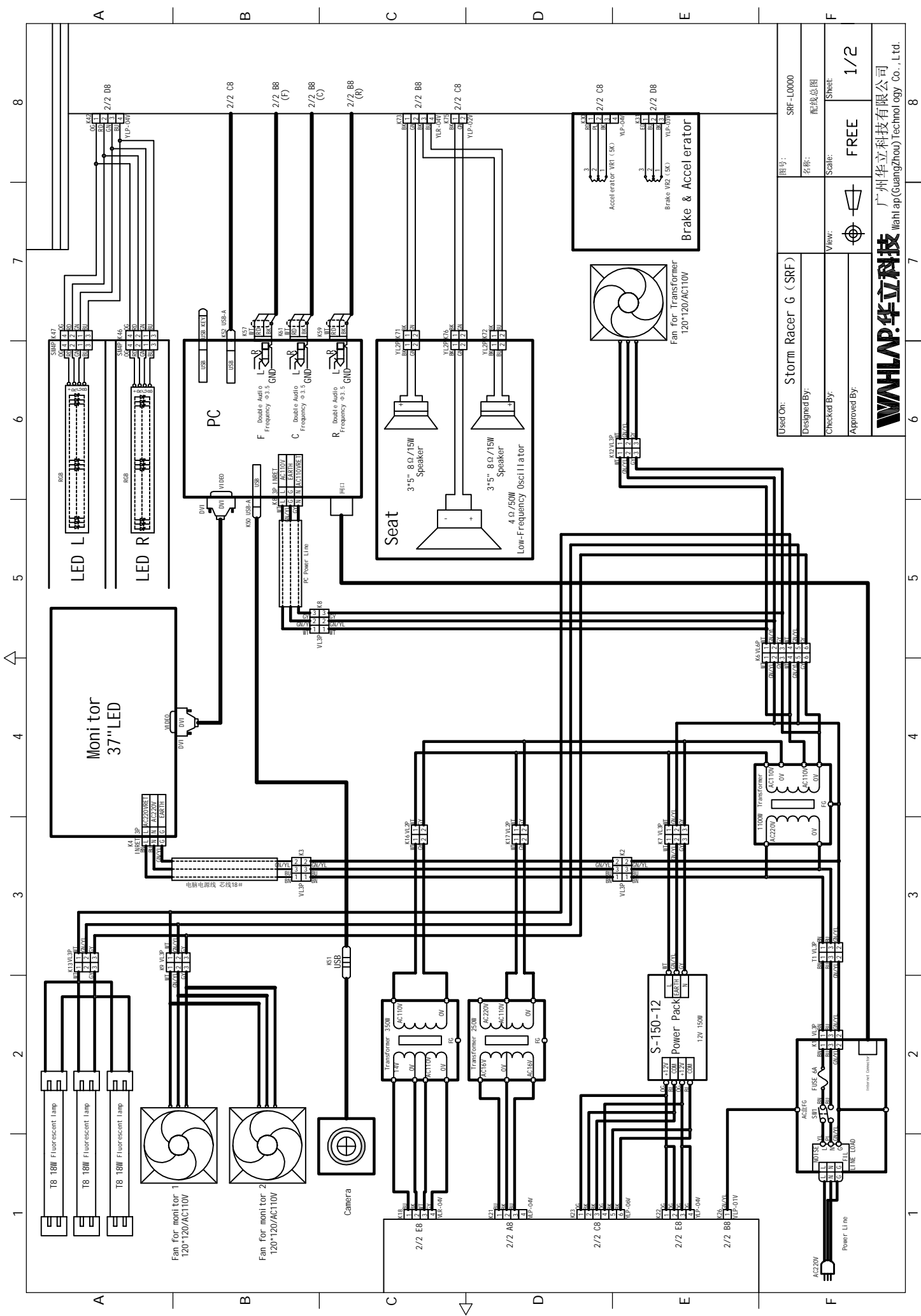

Used On:	S' storm Racer G (SRF)	图号:	SRF-L0000
Designed By:		名称:	配线总图
Checked By:		Scale:	FREE
Approved By:		Sheet:	1/2

WAHLAP.华立科技 广州华立科技有限公司
 Wahlap(Guangzhou) Technology Co., Ltd.

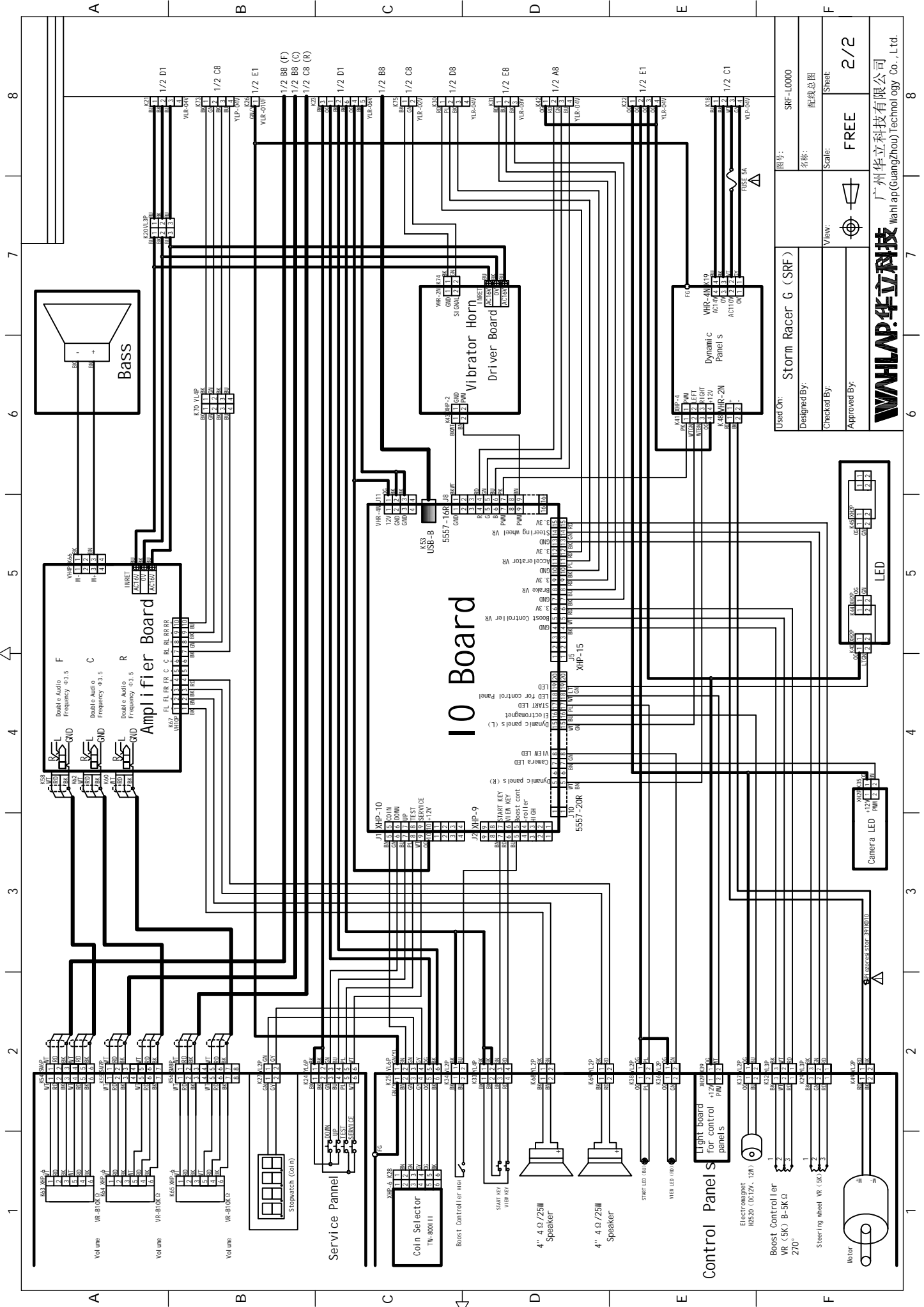

Used On:	Storm Racer G (SRF)	图号:	SRF-L0000
Designed By:		名称:	配线总图
Checked By:		View:	
Approved By:		Scale:	FREE
		Sheet:	2/2

WAHLAP.华立科技 广州华立科技有限公司
 Wahlap(Guangzhou) Technology Co., Ltd.

IO Board

9. After-sales Service

Honorable customer !

Thank you for purchasing our product !
For your benefits, if you find any fault during the operation of the product, please use a technician who obtains a certificate related to mechanical engineering, electrical engineering or who engages in routine maintenance, repair and management of amusement machine to check the machine and inform us the fault in a timely manner. Our company will take corresponding measures to assist you to solve the problem promptly.

NOTICE: Do not dismount or replace any part of the machine without our technician's permission, or you will solely undertake the consequence !

Please pay attention to our contact information as follow:

GuangZhou Wahlap Technology Limited

Add: H1-H6 Startoon city, Yingxing Dong Road, Donghuan Street, Panyu, Guangzhou, China

Tel: +86 20 39226222 Fax: +86 20 39226300

Service Hotline: +86 20 39226222 4006-926-222

E-mail: sales@wahlap.com Postcode: 511490

<http://www.wahlap.com>



Ver. 1.00

WHLAP[®]TECH

※ The specifications and operation instructions in this Manual are subject
to change without notice for reasons such as performance.
