



# **OWNERS AND SERVICE MANUAL**

## **INNOVATIVE CONCEPTS IN ENTERTAINMENT INC.**

10123 MAIN STREET, CLARENCE, NY 14031

SERVICE: 1-716-759-0360

FAX: 1-716-759-0884

E-MAIL: [service@icegame.com](mailto:service@icegame.com)

WEBSITE: [www.icegame.com](http://www.icegame.com)



# Table of Content

Installing the marquee	4
Loading Tickets	
Control Panel Functions	5
Meter Location	
Program Option	6
Error Codes	7
Software Revision	
ACCTNG/RESET function	8
Tilt	
50¢ Payout Wheel Guide	9
\$1 Payout Wheel Guide	10
\$2 Payout Wheel Guide	11
Diagnostic - Repair - Trouble Shooting	12
Diagnostic option 9	
Diagnostic option 8	
Diagnostic option 7	
Diagnostic option 6	
Power supply replacement	13
Wheel Illumination bulbs	14
Assemblies	16 - 22
Spares	25
Warranty	26

Rev C - 6/6/2011

## Installing The Marquee

The marquee is held on top of the game by four Allen bolts that are stored in the cash box during shipping. Place the marquee on top of the cabinet and insert the four Allen bolts from the inside bottom. You will need to open the upper back door to access the mounting holes. The location of the mounting holes are shown below with arrows. Once attached, connect the marquee harness and close the back upper door.

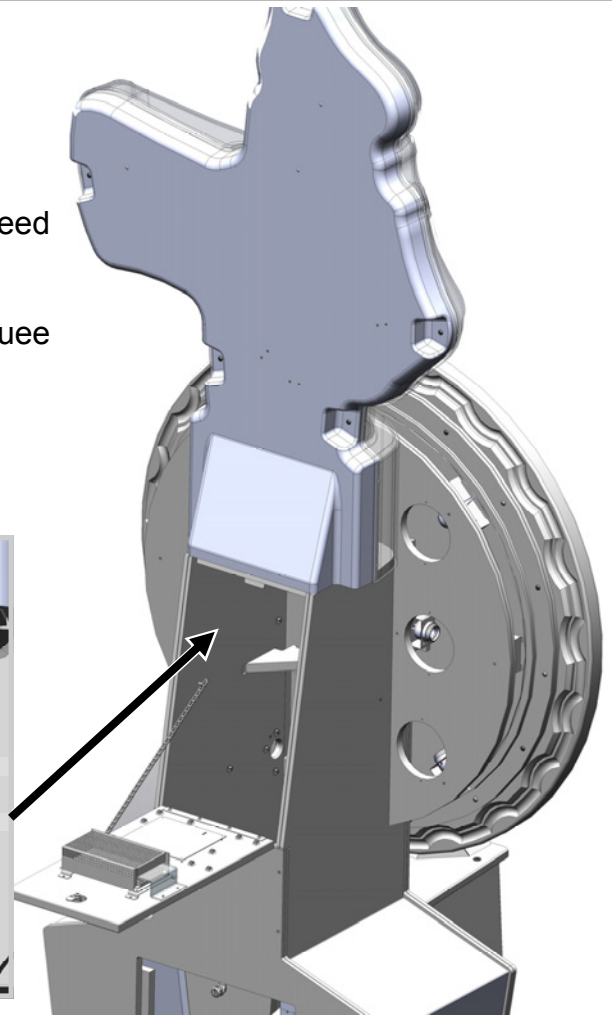
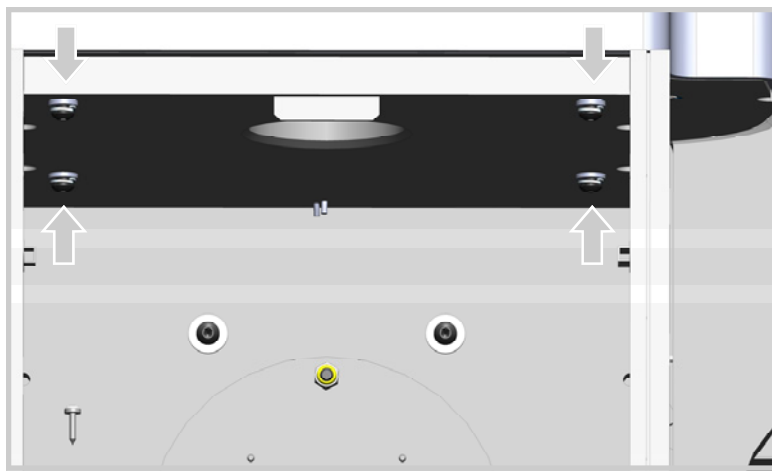

## Loading Tickets

There are two ticket dispensers located in the front drawer. The ticket drawer can hold up to 10000 tickets. To load tickets, loosen the side bracket (labeled 2 below) so that you can move the bracket up or down. Moving the bracket up will decrease the width of a ticket and moving the bracket down will increase the ticket width. Tighten when adjusted for your ticket width. Now slide the ticket through the two guide plates until they reach the rollers. Lift the top level (labeled 1) up to disengage the rollers so that a ticket can be pushed through. Press the ticket advance button located on the backside of the dispenser to test the ticket function.

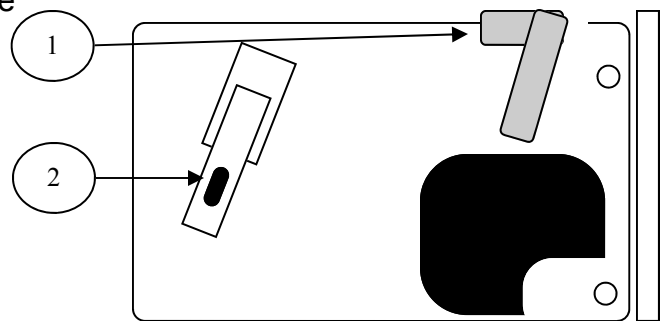

## Control Panel Functions

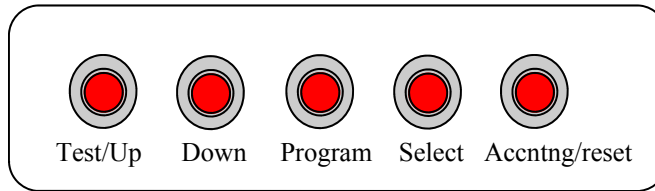

Located in the front drawer is a control panel used to change the game's settings, show accounting, and give a test credit. The Test/Up button has two functions. When the game is in programming mode, this button is used to increase the value for an option. When not in programming, this button will credit the game up without advancing the coin meter. The down button will decrease the value for an option. Pressing the program button will put the game into program mode and pressing it a second time will bring it out of programming mode. The select button is used to advance through each option. The acctng/reset button has two functions. Briefly pressing the button will put the game in accounting mode and pressing the button for 3 seconds will clear the accounting information. See "ACCNTG/RESET FUNCTION" for further details

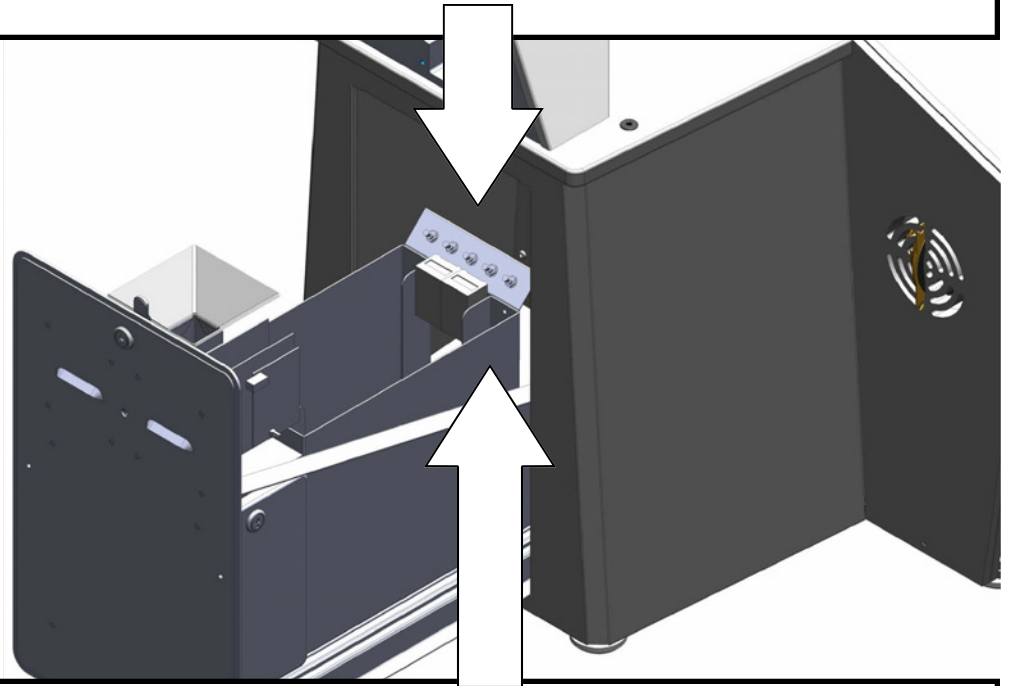

## Meter Location

There are two meters located below the control panel. The left meter will increment for each coin registered and the right meter will increment for each ticket that is paid out.

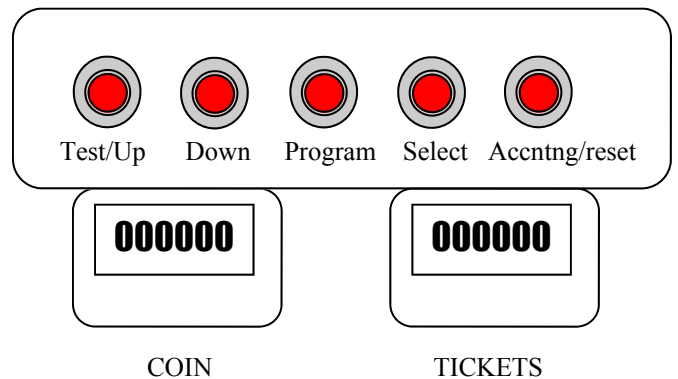

## Program Options

Press the program button to enter program mode. The option number will be displayed in the marquee display and the option value is displayed in the wheel display. Pressing the “Up” and “Down” buttons will increase or decrease the value. The select button will save that value and advance to the next option. When finished press the program button again to exit. The options are as follows:

Option	Description	Default value	Min	Max
0	Volume for music	3	0	7
1	Volume for the Voice & Clicker	6	0	7
2	Cost of game	4	0	10
3	Attract Time	1	1	90
4	1/2 Ticket output	0	0	1
5	Zone 1 value (highest)	1000	25	6375
6	Zone 2 value (left of highest)	100	25	6375
7	Zone 3 value (opposite of highest)	200	25	6375
8	Zone 4 value (right of highest)	100	25	6375
9	Tickets to add for progressive	0	0	25
10	Games lost until ticket add	0	0	10
11	Bonus Value	0	0	9999
12	Factory reset	0	0	1

### Option 0 and 1

These options set the volume level for your game. The lower the setting, the lower the volumes. The music volume and the pirate voice are adjusted separately.

### Option 2

This option tells the game how many coins it takes to start a game. This option should not be adjusted and should only be used when a card swipe system is installed. Your wheel values are based around a predetermined cost per play. Taking less or more money will impact your payout percentage.

### Option 3

Attract time determines

### Option 4

When the value of this option is 1 the game will only pay out half of the tickets owed.

### Option 5, 6, 7, 8

These options set your bonus zones. See “50¢ PAYOUT WHEEL GUIDE” and for further information. These options determines your payout percentage.

## **Program Options**

### **Option 9**

This option is only used when option 10 has a value greater than 0. This option will add the amount of tickets you set this value to. It will add it to zone 1 bonus value depending on the value in option 10. See next option..

### **Option 10**

Setting this option to any other number but zero will turn on the adjustable bonus feature. This option determines how many games must be played without hitting the bonus zones before adding the tickets you specified in option 9..

### **Option 11**

This determines the starting value for zone 1 bonus value when option 9 and 10 are used. When entering this value, the numbers will count in 25. This option is ignored if option 9 is 0.

### **Option 12**

Setting this to 1 and exiting programming will cause the game to display "load" on the wheel display. It will load its factory defaults.

## **Error Codes**

When power is applied the game will go through a brief self check. On the marquee display it will show you the version of software installed in the main board along with a wheel code. The wheel display will show you what software version is installed in the wheel board. If any errors are detected the game will display a E and a number indicating the error it has encountered. The game will also report any errors during game play and attract mode. The errors that you might encounter are:

1 = Ticket 1 error - Out of tickets

2 = Compact Flash error - Flash card cannot be read

4 = Wheel Communication error - Main board has no communication to wheel board

6 = Coin 1 stuck closed - Coin switch 1 is stuck or connected to normally closed.

7 = Coin 2 stuck closed - Coin switch 2 is stuck or connected to normally closed.

## **How To Read Your Software Revision.**

The marquee display's has 4 digits. Digit 1 (starting from the left) is the wheel number. The next three digits is the revision number for the software installed in the main board. The wheel display only displays the revision of software installed in the wheel encoder board.

## **ACCTNG/RESET function**

The “ACCNTNG/RESET” button located on the control panel has two different functions. When you press the button briefly the game will display in the wheel display how many times it has landed on the zone shown above on the marquee. Pressing the “UP” button will cycle through each of the zones showing you how many times it has landed on that zone. If the wheel becomes unbalanced, you will notice it will mostly land on the same zones. There are 50 zones on the wheel.

Zone 51 will inform you how many times the game has tilted.

Holding the “ACCNTNG/RESET” button down for 3 seconds will cause the game to display a “r” and clear all data pertaining to how many times a zone has been landed on.

## **Tilt**

The function of the tilt will only be enabled when the wheel is spinning. Bumping the cabinet while the wheel is spinning will cause the game to play a small jingle to indicate that the cabinet has been tilted. No tickets will be paid and the player will lose their credit. It will not tilt at any other time.



## 50¢ PAYOUT WHEEL GUIDE

The game's payout is based on the four bonus zones values. The values shown below will payout the percentage shown in each wheel's center. The game includes decals to change the zones if a different payout is desired. The zones are numbered counter clockwise starting from the top or highest value. The values between the bonus zones cannot be changed. If you turn on the adjustable bonus option, the numbers listed in the center should be set in option 11 as the starting value. Options 9 and 10 should both be set to 1. This will result in a 2% increase for the payout percentage. Adjusting the values in option 9 and 10 will alter the payout percentage.





# 1\$ PAYOUT WHEEL GUIDE

The game's payout is based on the four bonus zones values. The values shown below will payout the percentage shown in each wheel's center. The game includes decals to change the zones if a different payout is desired. The zones are numbered counter clockwise starting from the top or highest value. The values between the bonus zones cannot be changed. If you turn on the adjustable bonus option, the numbers listed in the center should be set in option 11 as the starting value. Options 9 and 10 should both be set to 1. This will result in a 1% increase for the payout percentage. Adjusting the values in option 9 and 10 will alter the payout percentage.





## 2\$ PAYOUT WHEEL GUIDE

The game's payout is based on the four bonus zones values. The values shown below will payout the percentage shown in each wheel's center. The game includes decals to change the zones if a different payout is desired. The zones are numbered counter clockwise starting from the top or highest value. The values between the bonus zones cannot be changed. If you turn on the adjustable bonus option, the numbers listed in the center should be set in option 11 as the starting value. Options 9 and 10 should both be set to 1. This will result in a 1% increase for the payout percentage. Adjusting the values in option 9 and 10 will alter the payout percentage.



## Diagnostic - Repair - Trouble Shooting

The game has built in error detection and diagnostics tools that help you determine what failure your game is having. See the section “Error Codes” for more information on built in error detection codes. The main circuit board has a rotary switch to enable different diagnostics tools. To access these tools, open the upper back door and locate the main circuit board. There is a small rotary switch that should be set to 0. Rotate this switch to the desired diagnostic tool you wish to use. The arrow indicates what number the switch is on. You will need to cycle power when setting this rotary switch.

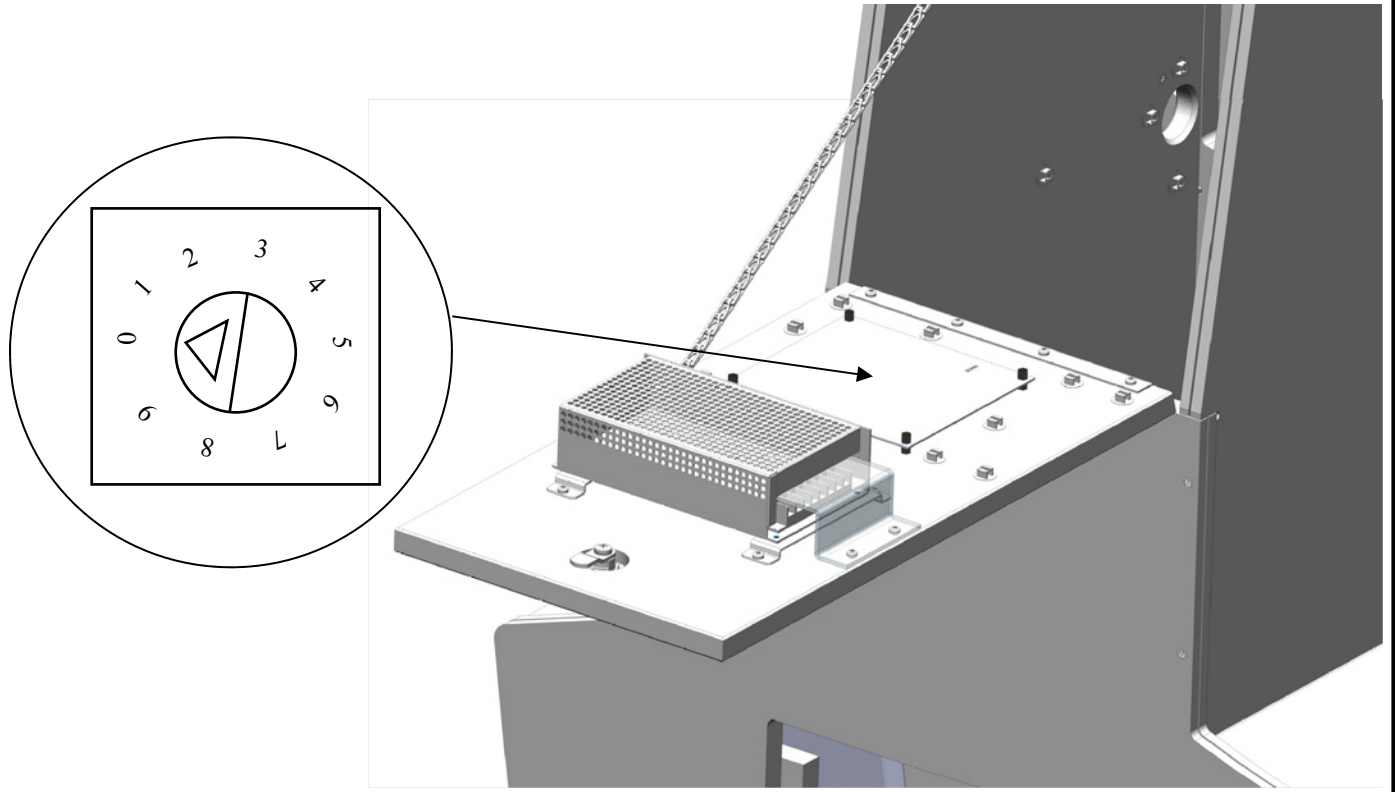

### Diagnostic option 9 - Use when improper amount tickets are paid out.

When this option is enabled the game will allow you to test the function of the game. When you credit the game up and spin the wheel, the wheel display will show you the speed of the wheel. The inner LED will be blue. When the speed of the wheel decreases, the inner LED will turn red to indicate that the speed is slow enough for the sensor to reliably read the position. The wheel display will show what segment it is reading. When the wheel stops, it will show you the amount of tickets that segment is worth. The wheel should match what is displayed.

### Diagnostic option 8 - Use when Error 4 is encountered.

When this option is enabled the game will test the main board's communication circuit. The display on the wheel will show “bad” until the center pins of J23 is shorted. You must unplug J23 on the main board and jumper the center pins. On a good board the display will change and display “good”. On a bad board it will still display “bad”. Replace the main board if the status doesn't change when shorted.

## Diagnostic option 7 - Wrong numbers displayed, verify display segments.

When this option is enabled the game will allow you to test the segments in all the displays. The game will cycle through numbers in order. Numbers should be clear and no segments should be missing. Replace the display if segments are missing.

## Diagnostic option 6 - Sensor errors are encountered.

When this option is enabled the game will display on the wheel display the status of the four sensors used to read the position of the wheel. The first digit starting from the left side is the home sensor status. When you spin the wheel this digital will show a 0 until it sees the home sensor then change to 1. It will go back to 0 when it goes past the home sensor. This should only go to 1 when it sees the home sensor. If it never goes to 1 then the home sensor is defective. The next digit is the optic for the clicker. Each time the clicker hits a pin, the number will go from 0 to 1 and back to 0 when it is past the pin. If this number doesn't change then the clicker optic is defective. The next two digits will tell the direction of the wheel. This tests the encoder wheel sensors which there are two of them. As you SLOWLY spin the wheel, in one direction the display will show on the last two digits 00, 10, 11, and then 01. It will repeat the sequence if you keep spinning it in that direction. Change the direction and the numbers will go 01, 11, 10, and then 00. If these digits do not change as you move the wheel then the encoder sensors are not working.

## Power supply replacement

The power supply is installed on the upper back door. You will need to open the back door to gain access to it. It is attached with four mounting screws shown with arrows.

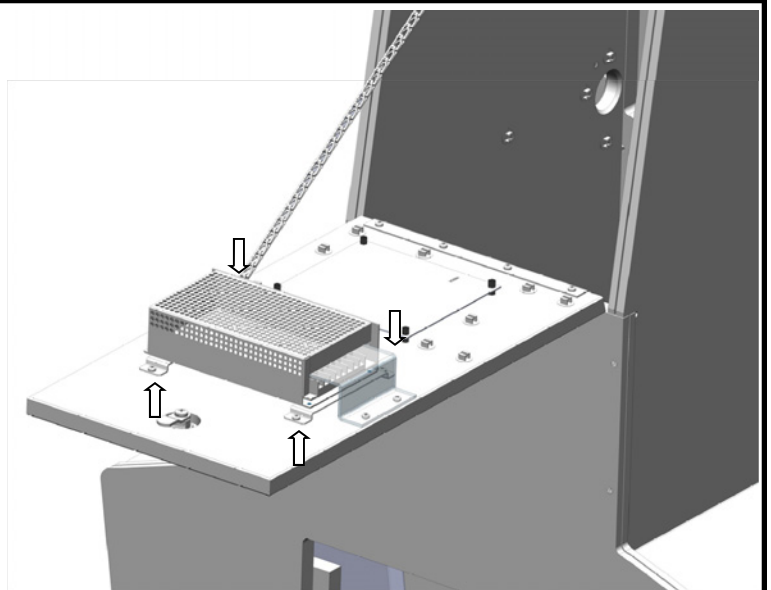



## Wheel Illumination bulbs

The wheel is lighted with 8 curly florescent bulbs. To replace the side bulbs, remove the small circle back cover behind the bulb you wish to replace. The bottom center bulb is replaced by opening the upper back cabinet door and reaching down to access the bulb. The upper center bulb can only be accessed by removing the marquee.

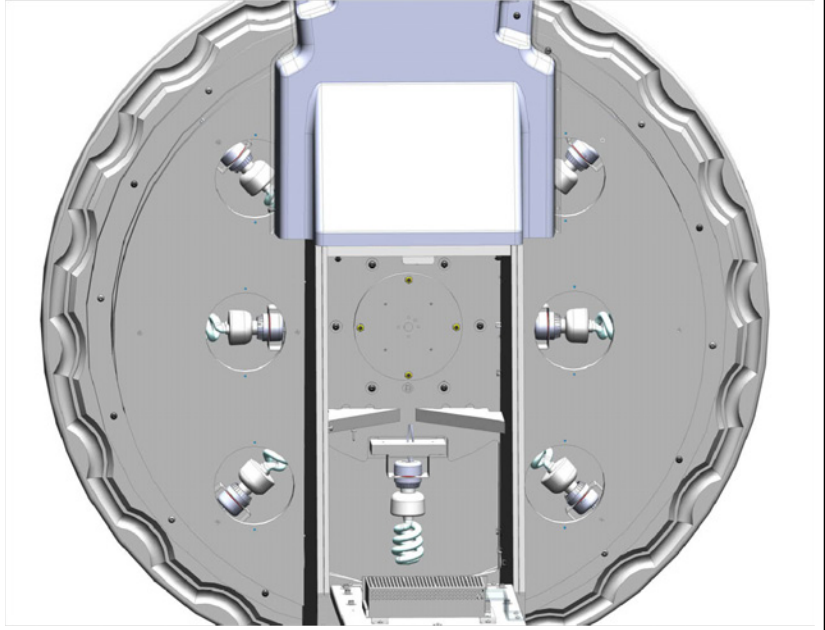

## Front Removal

If it becomes necessary to repair or you wish to change the bonus values' decals you will need to remove the front plastic. Leave a insert at the top until there is only one holding the plastic front onto the wheel. Rotate the wheel to the next insert. Do not remove the top insert until last as the plastic might come out and get damaged. Carefully remove the plastic and put aside.

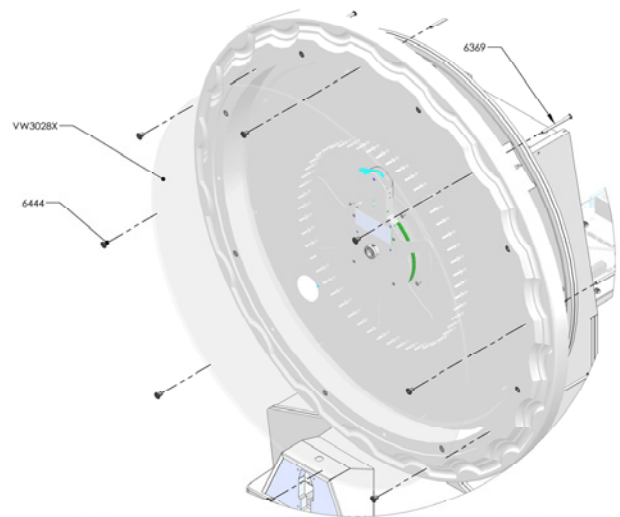

## Wheel Display/Clicker Removal

To gain access to the wheel sensors or to service the clicker assembly, remove the snap ring and its spacer. Then there are four Phillips screws that need to be removed and the assembly will then slide back. Disconnect the wire harness connectors before fully removing.

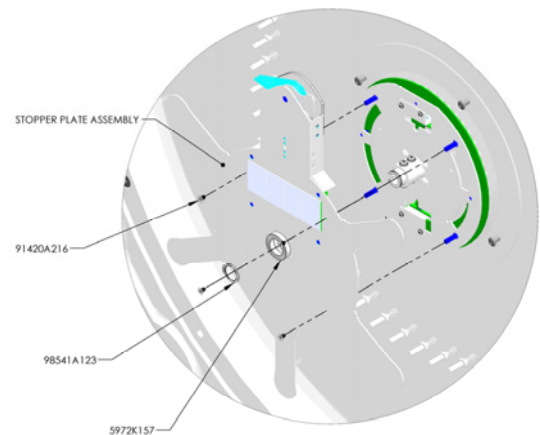

## Wheel encoder removal

There are two sensors used to detect wheel movement. One at the top and one at the bottom. The top sensor is referred to the encoder sensor while the bottom is referred to the point sensor. They are attached by two Phillips mounting screws. See drawing for further information. You will need to remove the front plastic and wheel display assembly to gain access to them.

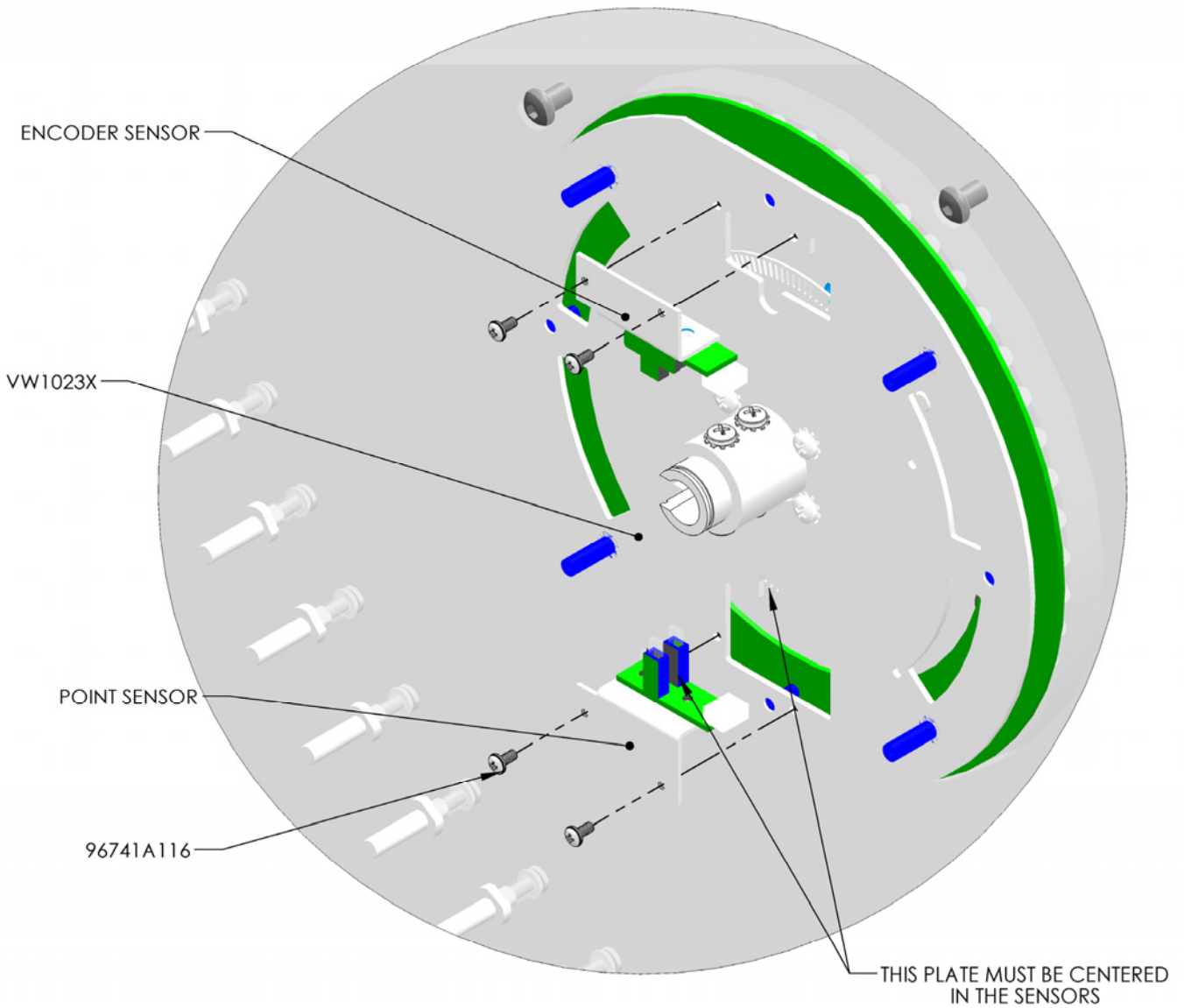

ITEM NO.	PART NUMBER	DESCRIPTION	QTY.
1	VW1007	TICKET DOOR	1
2	301-2590	ACCURIDE DRAWER SLIDE	2
3	VW1010	TICKET / COIN DRAWER	1
4	VW1005X	CASH BOX ASSEMBLY	1
5	5014	LOCK (710-010-01B)	1
6	VW3011X	CASH BOX DOOR ASSEMBLY	1
7	6004a	8-32 KEP NUT	12
8	6097	#6-32 HEX NUT	8
9	VW1019	COIN FUNNEL	2
10	HH5005CL	TICKET DISPENSER	2
11	E02289	BUTTON RESET	5
12	E02289 LOCK WASHER	BUTTON RESET LOCK WASHER	5
13	E02289 NUT	BUTTON RESET NUT	5
14	5014-1 BARREL	CAM LOCK BODY	1
15	5014 NUT	3/4" NUT	1
16	5014-2 CAM	LOCK CAM	1
17	5014 SCREW	PPH SCREW	1

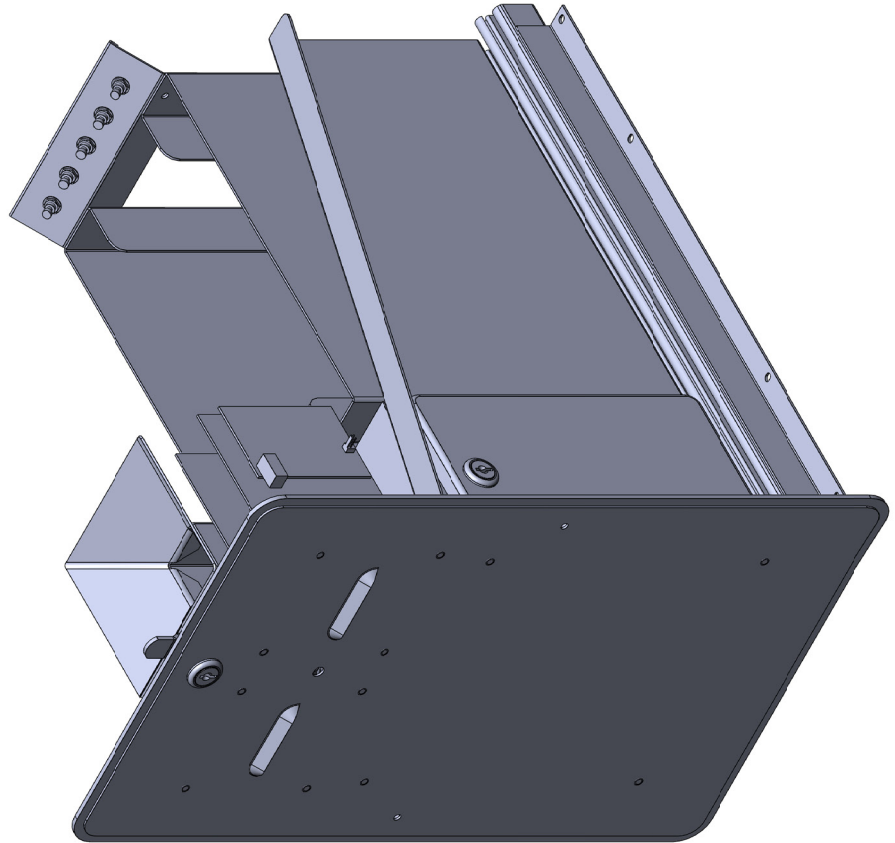



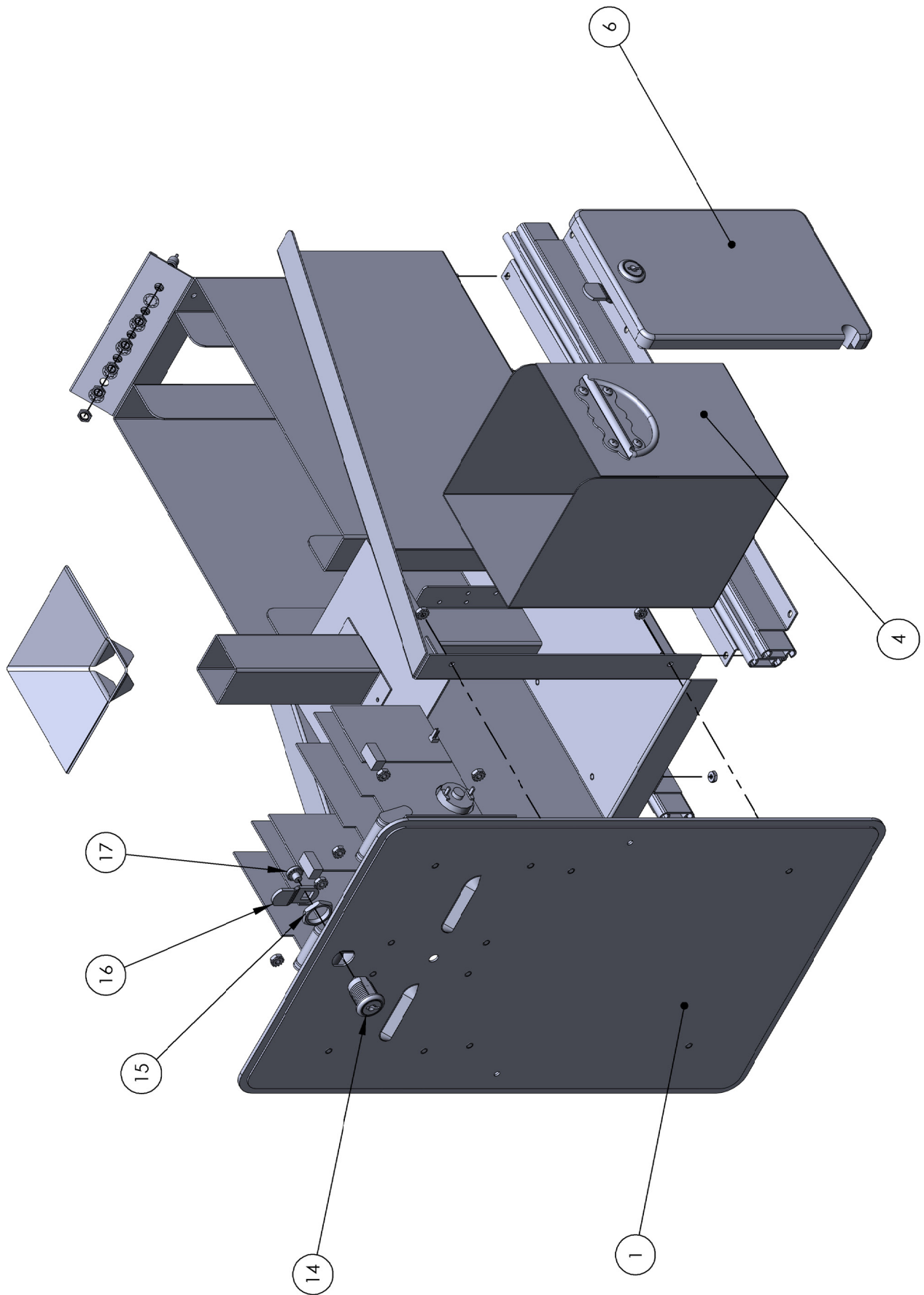

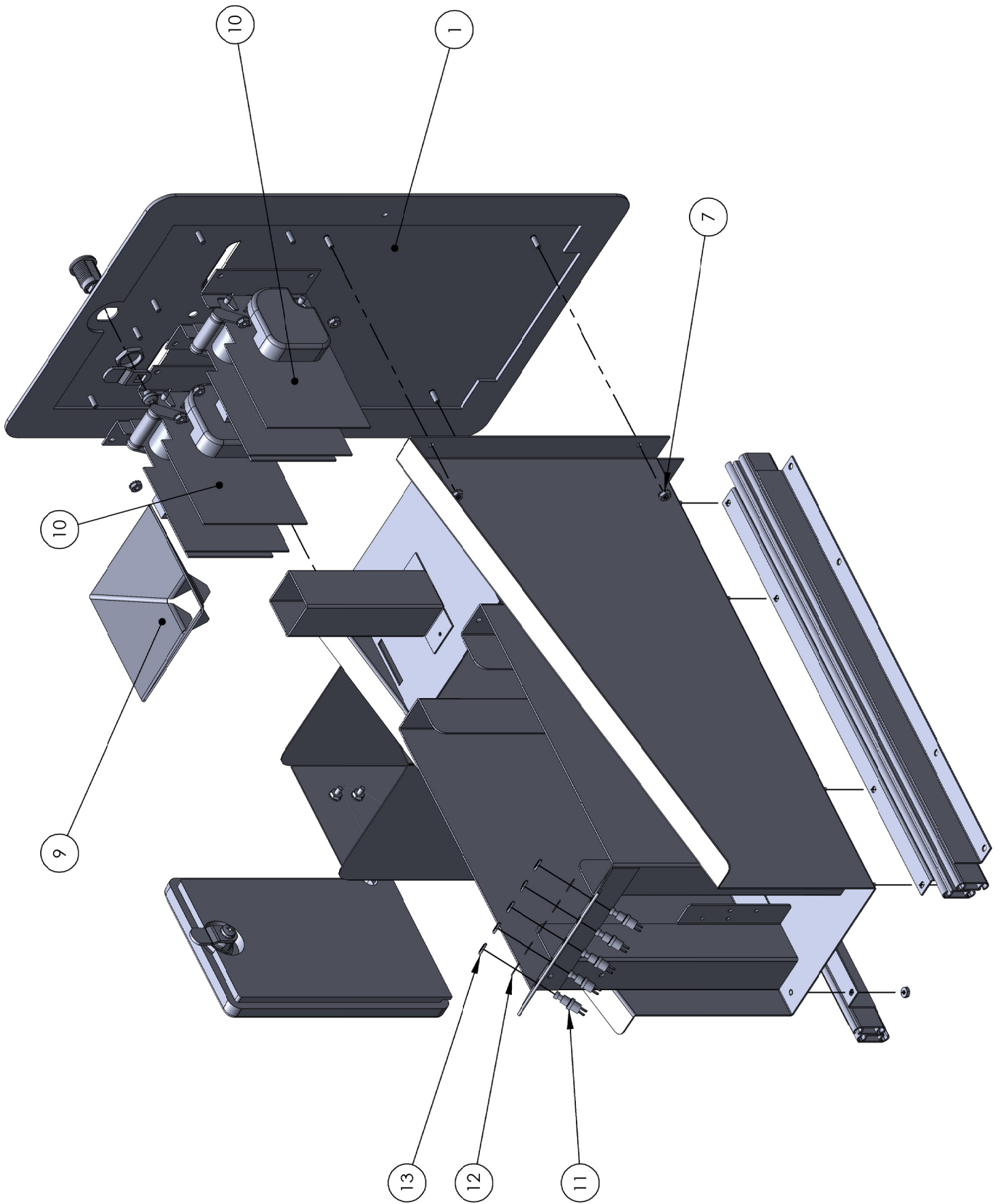

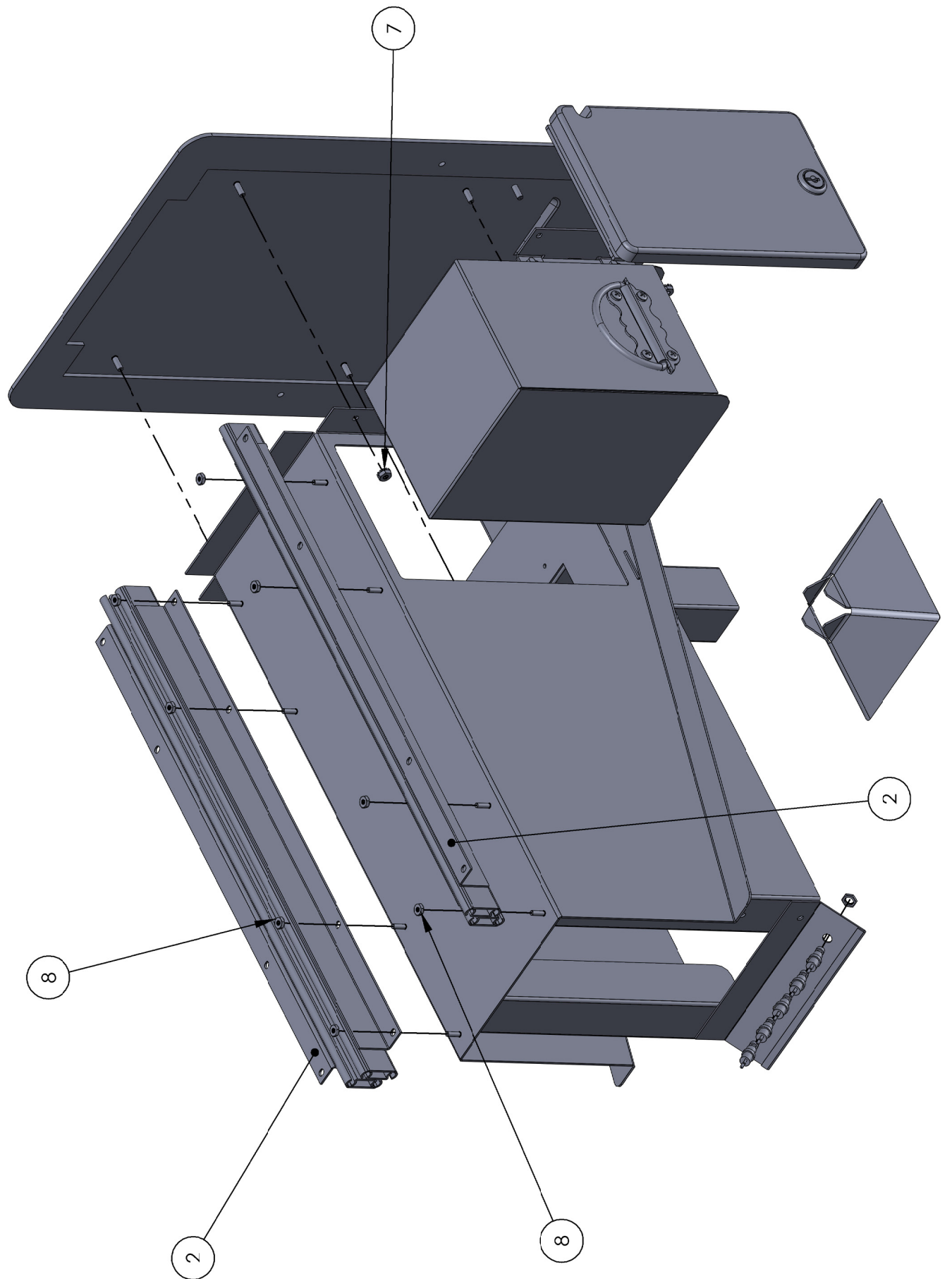

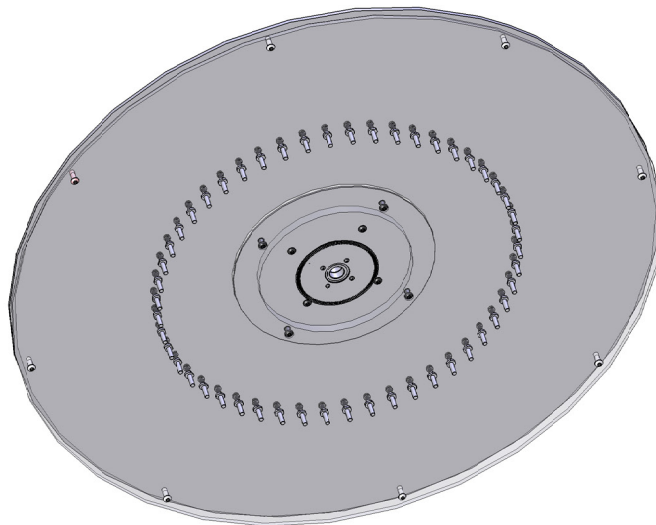

ITEM NO.	PART NUMBER	DESCRIPTION	QTY.
1	VW3080	VALUE WHEEL	1
2	WHEEL PIN	WHEEL PIN	50
3	91166A230	M4 FLAT WASHER	50
4	91202A226	M4 SPLIT WASHER	50
5	92005A222	M4 x 12 MM MACHINE SCREW	50
6	VW1013	WHEEL PLATE	1
7	pc60601	1/4-20 x 5/8 BSHCS (BLACK)	8
8	VW7010	WHEEL VALUE GRAPHIC	1
9	PC60622	1/4-20 x 1.00" LG. BSHCS	8
10	PC60604	NYLOCK NUT, 1/4-20	8
11	CLUTCH PLATE ASSEMBLY	CLUTCH PLATE ASSY	1

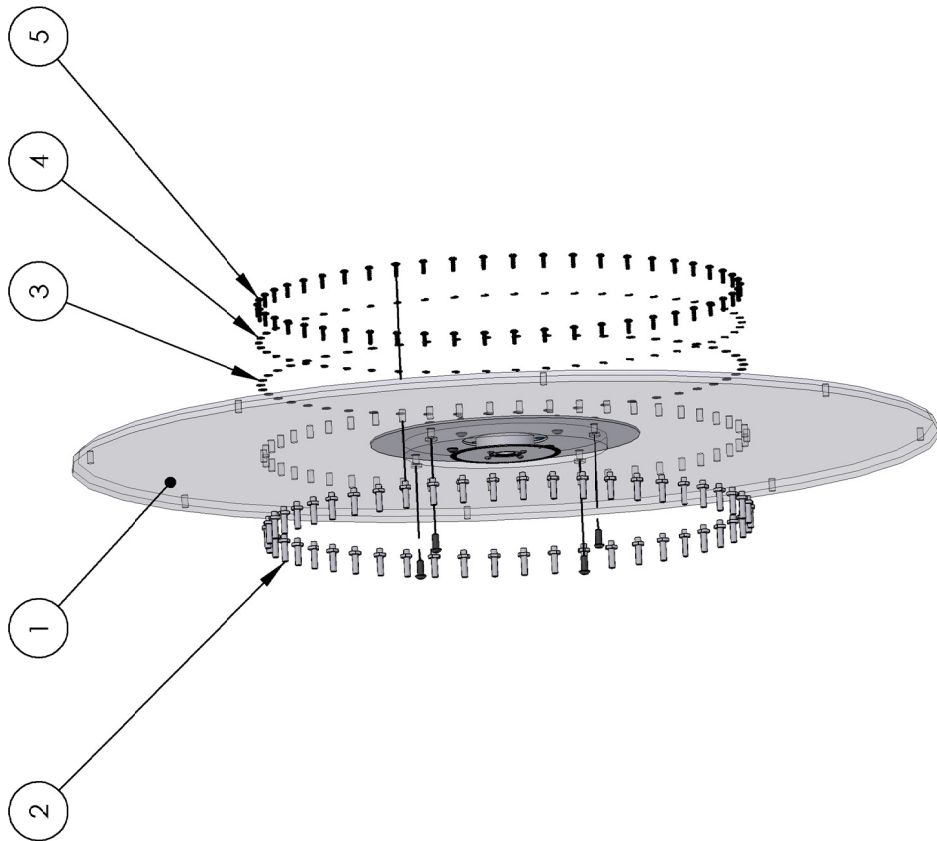
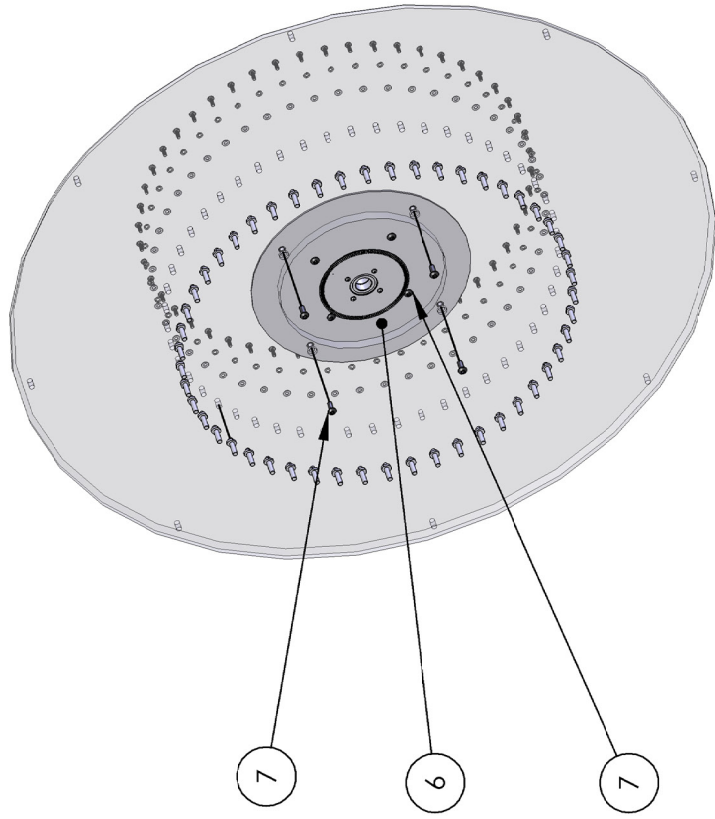

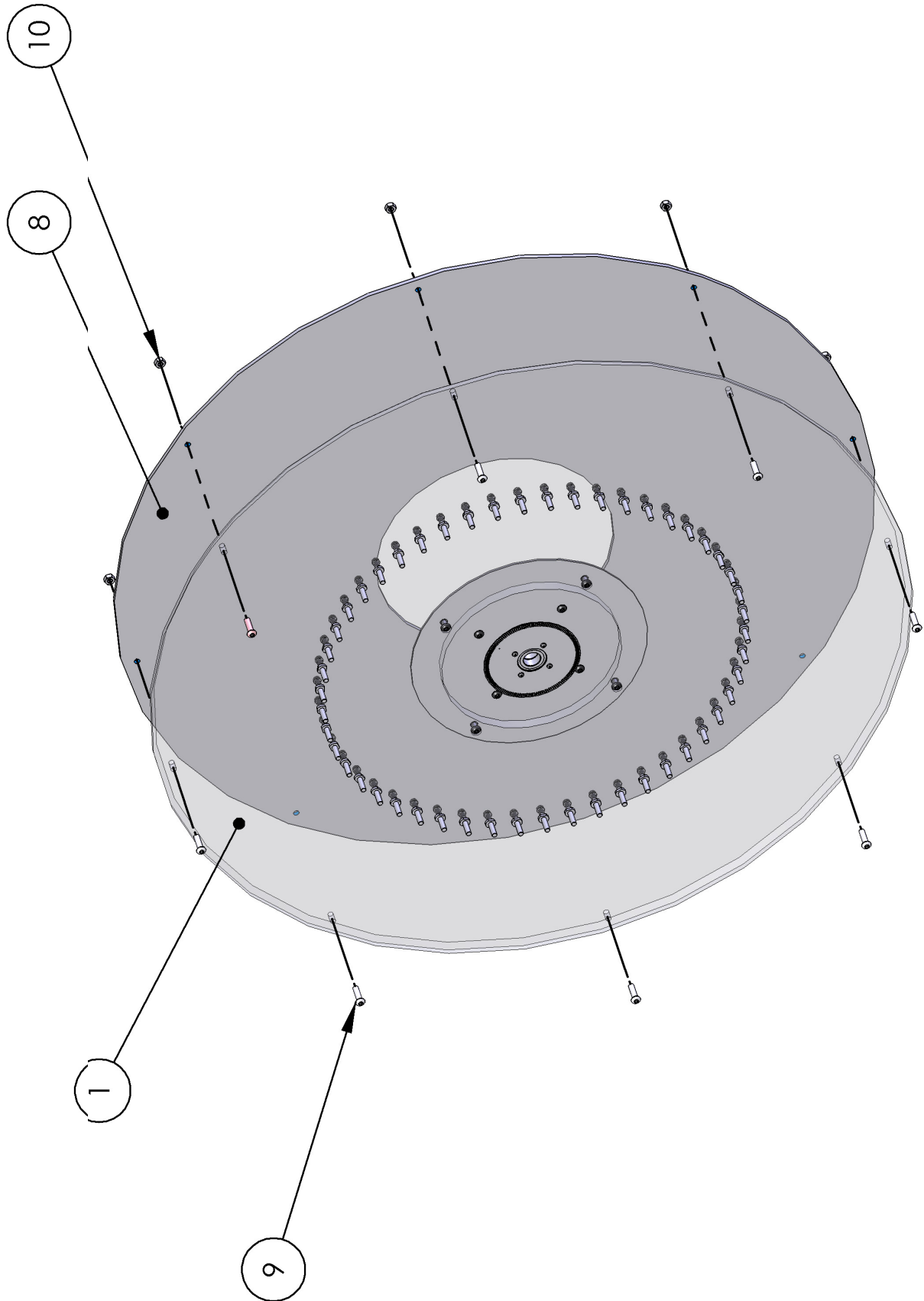

ITEM NO.	PART NUMBER	DESCRIPTION	QTY.
1	VW3158	UPPER BACK DOOR	1
2	VW1006	BACK DOOR HINGE	1
3	5014-1 BARREL	CAM LOCK BODY	1
4	5014 NUT	3/4" NUT	1
5	5014 SCREW	PPH SCREW	1
6	5014-2 CAM	LOCK CAM	1
7	655S	#8 x 5/8 SQ. DRIVE (SILVER)	10
8	6203	FH-632-20	4
9	PC60643	6-32 x 1/4 HH SPACER	8
10	VW MAIN	IO BOARD	1
11	VW2010	POWER SUPPLY	1
12	DN3099	POWER SUPPLY TERMINAL GUARD	1

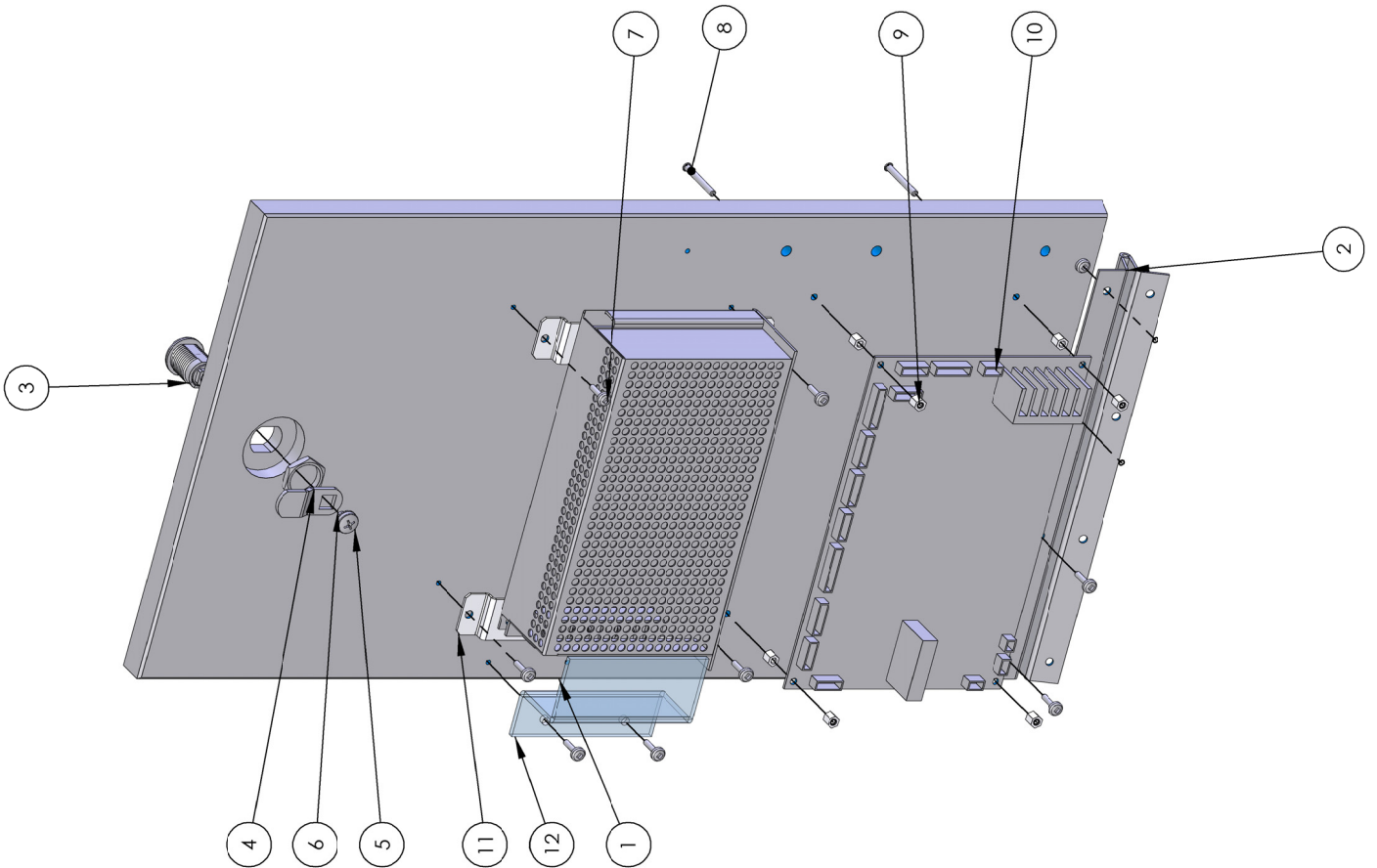
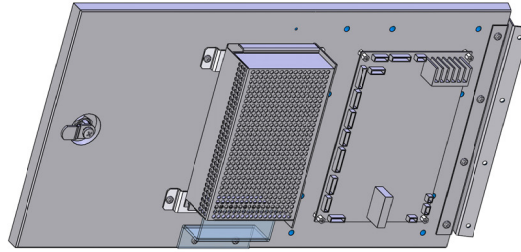



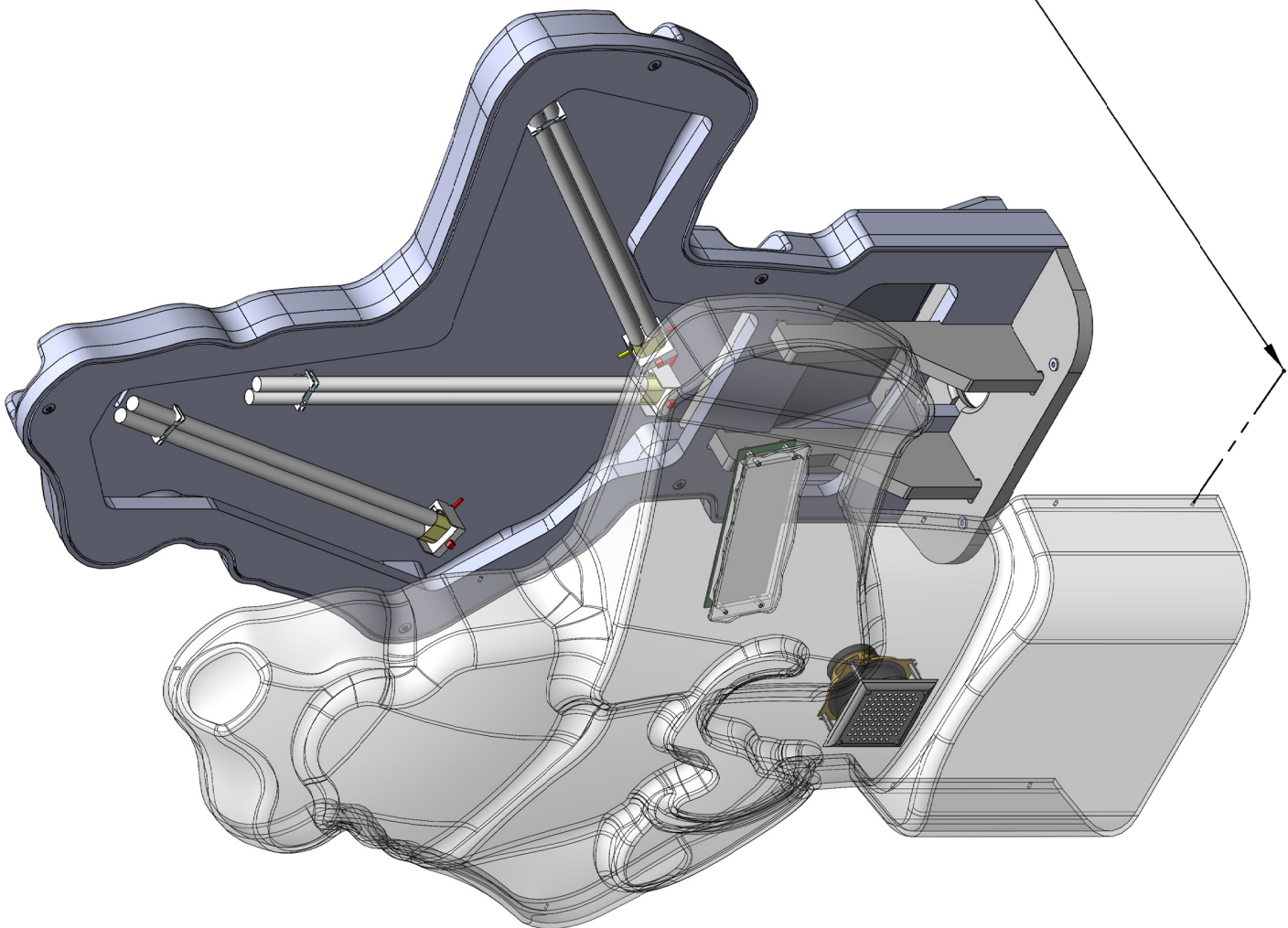

CONNECT FRONT USING (11) 655  
AROUND PERIMETER



## Mech/Electrical Spares

8312	Bulb PL-L 40W Marquee lighting
6792	40MM snap ring
6795	20MM snap ring
E00253	CF bulb 13w 4100k Cool white
E02315	3amp fuse slo-blow
FP2007	4" speakers
VW1005	Cash box
VW2010	Power supply
VW2032X	PCB Jackpot
VW2034X	Main board
HH5005CL	Ticket dispenser
DD2007X	Power module
207	T Molding ½" Black
213	T Molding 25/32"
50C14	7/8 cam lock
5015F	Lock cam
CP1051	Tilt sensor
CR1050	Anti slam switch
DD2007X	Power Module
E2034X	Brain Board
E00253	13W 4100K Cool White CF Bulb
FP2007	4" Speaker
HH5005cl	Ticket Dispenser
PE1350	Drawer Slide 18
VW1007-P800	Ticket Door
VW1019-P800	Coin Funnel
VW1051	Clutch Assembly
VW1053x	Stop Assembly
VW2010	Power supply
VW2034X	Main I/O
VW2050HX	Main harness
VW2053HX	Ticket Drawer harness
VW2060LX	DC Power
VW2061MX	Power supply extension harness
VW2062LX	Ballast extension Harness
VW2063MX	AC Lighting Harness
VW1013-P700	Wheel Plate
VW1023	Hub Rev C
VW1025	Hub Spinner
VW1054	Hub Outer wheel Rev A
VW1056	Hub Inner wheel Rev B
VW1150	20mm Shaft bearing
VW3028	Front Glass
8312	PL-L 40W fluores
BG3002	Grille 4" speaker
CX8384X	Ballast Work Horse 5
VW2032X	Jack Pot Ticket find

VW2080LX	Jack Pot display harnesss
VW1040X	Clicker assembly w/spring
VW2042X	Top sensor
VW2040X	Encoder sensor
VW2041X	Point sensor
VW2035X	LED ring board

## Spares

VW7000	Decal cabinet side
VW7001	Decal cabinet front left
VW7002	Decal cabinet front right
VW7003	Decal ticket door
VW7004	Decal wheel hub
VW7006	Decal steering wheel
VW7011	Decal spin wheel
VW3140	Red Filter Marquee
VW7127	Pirate
VW7140	Marquee Frame overlay



# WARRANTY POLICY

I.C.E. Inc warrants all components in new machines to be free of defects in materials and workmanship for the period listed below:

- 180 days on Main PCB's, Computers & Motors
- 1 year on all LCD monitor panels
- 90 days on all other electronic and mechanical components
- 30 days on all I.C.E. repairs and parts purchases

I.C.E. Inc shall not be obligated to furnish a warranty request under the following conditions:

- Equipment or parts have failed through normal wear and tear
- Equipment has been subjected to unwarranted stress, abuse or neglect
- Equipment has been damaged as a result of arbitrary repair/modification

Products will only be covered under warranty by obtaining an I.C.E. authorized RMA #. To obtain an RMA # please provide I.C.E. tech support with the game serial # or original I.C.E. invoice # and a detailed description of the failure or fault symptoms.

I.C.E. Inc will assume no liability whatsoever for costs associated with labor or travel time to replace defective parts. All defective warranty covered components will be replaced with new or factory refurbished components equal to OEM specifications.

I.C.E. Inc will cover domestic UPS ground, or comparable shipping costs during the warranty period. International or expedited shipments are available for an additional charge. To obtain credit defective parts must be returned to I.C.E. Inc, at the customer's expense, within 30 days. After 30 days a 15% re-stocking fee will apply to all returns.

ICE distributors are independent, privately owned and operated. In their judgment, they may sell parts and/or accessories other than those manufactured by I.C.E. Inc. We cannot be responsible for the quality, suitability or safety of any non-I.C.E. part or modification (including labor) that is performed by such a distributor.

**Innovative Concepts in Entertainment**

**10123 Main St.**

**Clarence, NY 14031**

**Phone #: (716) - 759 – 0360**

**Fax #: (716) – 759 – 0884**

**[www.icegame.com](http://www.icegame.com)**