



DRAFT VERSION

REGISTER YOUR PRODUCT!

ENGLISH

→ On the web at www.archos.com/register

Thank you for choosing this ARCHOS product. We hope that you will enjoy using it and that it will give you satisfaction for many years to come. Once you unpack your ARCHOS product, we recommend that you take a few minutes to register it (www.archos.com/register). This will allow you to get access to ARCHOS technical support (www.archos.com/support).



NEED HELP?



On our Website: See the Frequently Asked Questions section on www.archos.com/faq



Contact our Technical Support Team: Visit www.archos.com/support for e-mail support. *U.S. & Canada: Call 877-300-8879 (toll free). Europe: please register your product before contacting Technical Support (see Register your Product).*

As we are often updating and improving our products, your device's software may have a slightly different appearance or modified functionality than presented in this Quick Start Guide.

P/N: 108710



DRAFT VERSION

DESCRIPTION OF THE DEVICE

- 1 **SD Memory card reader:** Insert an SD card from a camera and view photos on the ARCHOS.
- 2 **USB Host port:** To connect a keyboard, a mouse or a mass storage USB device (for example a USB stick)
- 3 **USB Device port:** to connect your ARCHOS to your computer, using the included USB cable.
- 4 **On/Off:** Pinch* and hold to turn on or to show shutdown options
- 5 **Charging indicator:** Red light: battery charging / Yellow: battery charged.
- 6 **Hardware Reset:** In the event that your ARCHOS freezes operation, you can press the "pinhole reset" button, located on the back the device, by using a narrow object such as a toothpick.
- 7 **Software Update button:** Make sure your device has a connection to the internet. Press this update button and your ARCHOS will check to see if there is a newer firmware available for your device. Follow the screen instructions to update to the latest version.
- 8 **Power connector:** to connect the supplied power cable.
- 9 **Headphone jack**
- 10 **Loudspeakers**

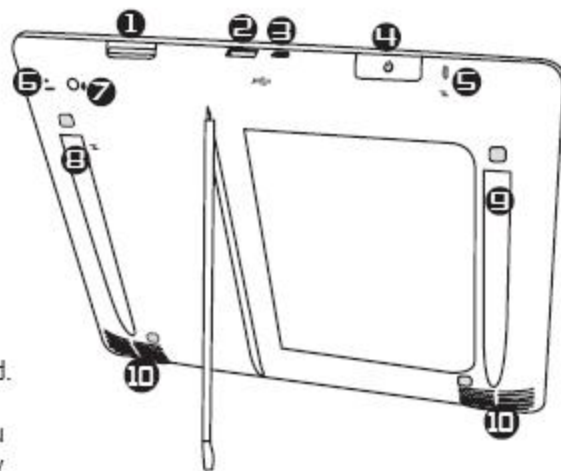

* On/Off/Wake





Before using your ARCHOS for the first time, completely charge the battery!

Charging the Battery

- 1 Connect the supplied power cable to the ARCHOS Power connector and to a wall outlet.
- 2 The ARCHOS device will turn on and start charging. The Power indicator light is red while the battery is charging. It will turn yellow when the battery is fully charged.

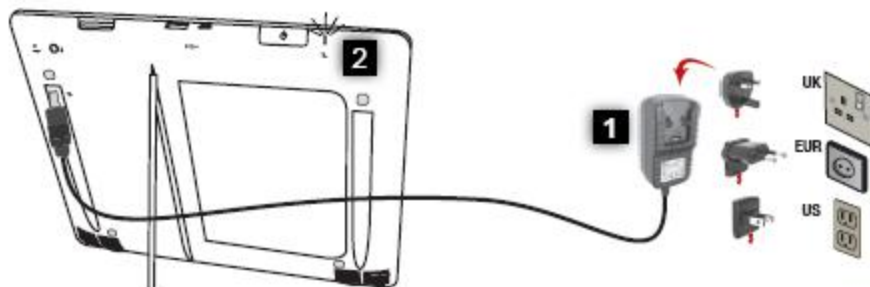

Installation Wizard

The first time you start up your ARCHOS, the installation wizard will bring you through a few screens to help you set up the principal settings: Language, country, time, etc.



THE ARCHOS INTERFACE

Your ARCHOS device is equipped with a touchscreen. Most screen areas will react when you tap on them with your finger.

Home Screen

These are the default Android™ shortcuts (**Web Browser**, **E-Mail**, etc.). Tap on an icon to open the corresponding application. You can customize the Home screen by adding/removing shortcuts and widgets, changing the wallpaper, etc. See next page.



Applications Tab

Tap on this icon to reveal all the Android™ applications installed on your ARCHOS (games, various tools, etc.). You can copy them onto the Home screen. You can get more Android™ applications from the AppsLib which can be found on the Home screen.

Top bar of the Interface (varies according to the screen you are in)





DRAFT VERSION

CUSTOMIZING YOUR PRODUCT



ENGLISH

The extended Home screen

Slide your finger horizontally on the screen to go to the left or right side of the extended Home screen.



Customizing the Home screen items

- To add a Home screen item (shortcuts, widgets, etc.), hold your finger on the screen at an empty location, then choose from the list. You can also tap on the Menu icon  and select **Add** , at the bottom of the screen.
- To move a Home screen item, hold your finger onto it until it gets larger, then drag it to the desired location, and release your finger.
- To remove a Home screen item, hold your finger onto it, drag it onto the recycle bin (while you're holding an item, the **Applications** tab, on the right side of the screen, turns into a recycle bin) and release your finger.



Changing the wallpaper: From the Home screen, tap on the Menu icon . A list of options appears at the bottom of the screen. Tap on **Wallpaper**  then choose from the list.



Adding more applications: With the ARCHOS connected to the Internet, tap on the AppsLib icon  on the Home screen. This online library of free and purchasable applications has hundreds of fun and useful games and applications to download and use.







DRAFT VERSION

CONNECTING TO THE INTERNET



First of all, you need to configure a WiFi network. For this procedure to work, you need to be in a WiFi zone that will allow you to connect to it. Every time the ARCHOS is in range of a network that you have already configured once, it will attempt to make a connection.

1 To configure a new WiFi network, go on the Home screen, tap on the Menu icon  then select **Settings** .

2 In the **Settings** screen, select **Wireless controls**.



3 If the WiFi is off, tap on the **Wi-Fi** line to turn it on. Then select **Wi-Fi settings**. The ARCHOS will scan for available WiFi networks and display them at the bottom of the screen.



4 Tap on the network you want to connect to, enter the required network information* and then tap on **Connect**. Your ARCHOS will now attempt to establish a connection to that WiFi hot spot with the network parameters you entered.

* For free access WiFi points, there is no need to enter any special information. For secured networks, you will need either a key (a series of numbers and/or letters) of the type WEP, WPA, or WPA2. Check with the person who manages the WiFi network to obtain the exact connection parameters required.



PLAYING MULTIMEDIA FILES





- 1 From the Home screen, tap on the video, audio or photo application.
- 2 The ARCHOS will display a list of files or folders corresponding to the selected category.
- 3 Tap on an item to start playing it.



Only in Video and Photo modes: to display/hide the on-screen controls, tap anywhere on the screen.



Video

To pause or resume a video, tap on the icon  /  (bottom of screen). To go to any particular point in the video, slide the progression bar to the desired point.







Music

To play the next or previous song, tap on the icons  / . Use the icons  /  and the progression bar as in the video player screen (see above).



Photo

To start or pause a slide show, tap on the icon  / . To view the next or previous photo, tap on the icons  / .

TRANSFERRING MEDIA TO YOUR ARCHOS

- 1 Connect the supplied USB cable to the ARCHOS and to a running computer.
- 2 The ARCHOS will turn on and ask you if you want to connect it. Tap on "Mount" to connect it. Within a few seconds the ARCHOS will appear as an icon on your computer.
- 3 You can transfer your media files to the ARCHOS either by copy/pasting them into the respective folders using Windows® Explorer (or the Finder on a Mac®), or by using Windows Media® Player. Open Windows Media Player® and then use the **Sync** tab to synchronize your music, videos, and photos onto your ARCHOS. See Windows Media Player®'s Help to learn more about this.
- 4 Once all your file transfers are finished, close Windows® Explorer and any other program that may have read or written to the ARCHOS. Click on the 'safely remove' icon in the system tray, next to the clock. You can now unplug the USB cable.

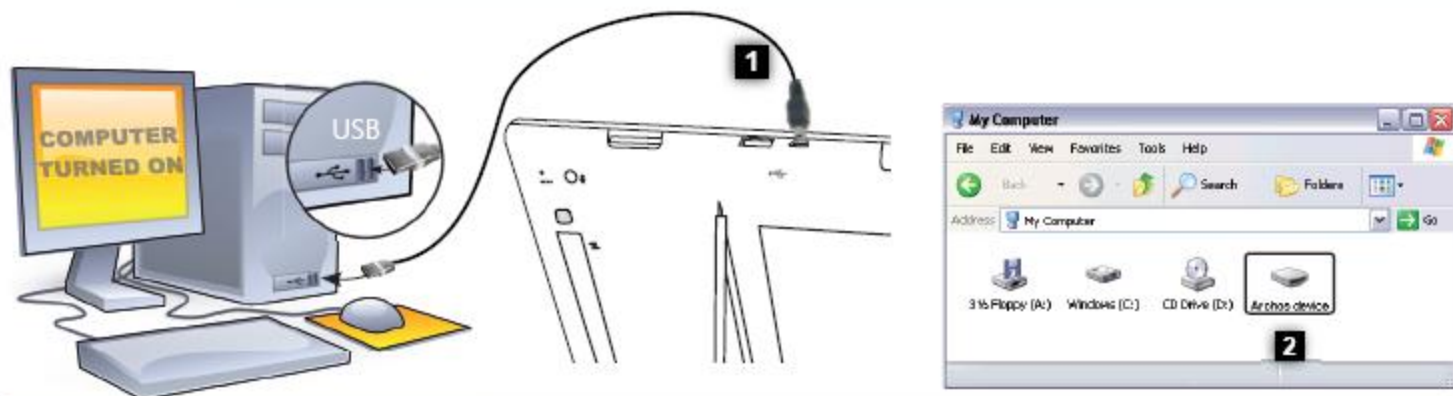

FCC warning statement

This equipment has been tested and found to comply with the limits for a Class A digital device, pursuant to part 15 of the FCC Rules. These limits are designed to provide reasonable protection against harmful interference in a residential installation. This equipment generates, uses and can radiate radio frequency energy and, if not installed and used in accordance with the instructions, may cause harmful interference to radio communications. However, there is no guarantee that interference will not occur in a particular installation. If this equipment does cause harmful interference to radio or television reception, which can be determined by turning the equipment off and on, the user is encouraged to try to correct the interference by one or more of the following measures:

- Reorient or relocate the receiving antenna.
- Increase the separation between the equipment and receiver.
- Connect the equipment into an outlet on a circuit different from that to which the receiver is connected.
- Consult the dealer or an experienced radio/TV technician for help.

Caution: Any changes or modifications to this device not explicitly approved by manufacturer could void your authority to operate this equipment.

This device complies with part 15 of the FCC Rules. Operation is subject to the following two conditions: (1) This device may not cause harmful interference, and (2) this device must accept any interference received, including interference that may cause undesired operation.

RF warning statement:

The device has been evaluated to meet general RF exposure requirement. The device can be used in portable exposure condition without restriction.

CE in which countries where the product may be used freely: Germany, UK, Italy, Spain, Belgium, Netherlands, Portugal, Greece, Ireland, Denmark, Luxembourg, Austria, Finland, Sweden, Norway and Iceland. France: except the channel 10 through 13, law prohibits the use of other channels.