



ARCXtend™ System

Planning and Installation Guide

**A License-Free Point-To-Multipoint
Wireless Cable Plant Extension Solution**

October 2003

© 2001-2003 Arcwave, Inc.

910 Campisi Way, Suite 1F, Campbell, CA 95008 USA, Phone: 408-558-2300

www.arcwaveinc.com

Customer Service: 408-748-7570

techsupport@arcwaveinc.com

PN: 920-20003-001

LIMITED WARRANTY. Arcwave warrants to Buyer at the time of delivery that the equipment will be free from defects in material and workmanship under normal use and service. Arcwave's sole obligation under these warranties is limited to replacing or repairing, at its option, at its factory, any equipment that is returned to Arcwave, transportation, duties, and taxes prepaid, within twelve (12) months after delivery. In the case of products not of Arcwave's own manufacture, the only warranty available is that provided by the original equipment manufacturer. Arcwave shall return the equipment to Buyer freight prepaid. THIS WARRANTY IS EXPRESSED IN LIEU OF ALL OTHER WARRANTIES, EXPRESS, IMPLIED OR STATUTORY, INCLUDING THE IMPLIED WARRANTIES OF MERCHANTABILITY AND FITNESS FOR A PARTICULAR PURPOSE, AND OF ALL OTHER OBLIGATIONS OR LIABILITIES ON THE PART OF Arcwave, AND IT NEITHER ASSUMES NOR AUTHORIZES ANY OTHER PERSON TO ASSUME FOR ARCWAVE ANY OTHER LIABILITIES IN CONNECTION WITH THE SALE OF PRODUCTS. IN NO EVENT WILL Arcwave BE LIABLE FOR CONSEQUENTIAL DAMAGES EVEN IF Arcwave HAS BEEN ADVISED OF THE POSSIBILITY OF SUCH DAMAGES. This Warranty does not apply to any of such products, which shall have been repaired or altered, except by Arcwave, or which shall have been subjected to misuse, negligence, or accident or operation outside the environmental specifications. Repairs or replacements of Equipment made during the warranty period or thereafter will be warranted, as provided above, for the remainder of the original warranty period or for ninety days from the date of return, as applicable, whichever is longer.

RETURN OF EQUIPMENT UNDER WARRANTY: If an item of Equipment malfunctions or fails in normal intended usage and maintenance within the applicable Warranty Period:

- (a) The Customer shall promptly notify Arcwave of the problem and the serial number of the defective item;
- (b) Arcwave shall, at its sole option, either resolve the problem over the telephone or provide the Customer with a Returned Materials Authorization number (RMA #) and the address of the location to which the Customer may ship the defective item;
- (c) If the problem is not resolved over the telephone, the Customer shall attach a label to each returned item describing the fault and the Customer's return address. The Customer shall, at its cost, properly pack the item to be returned, prepay the insurance and shipping charges, and ship the item to the specified location;
- (d) If the Arcwave product shall prove to be defective in material or workmanship upon examination by Arcwave, Arcwave shall either repair or replace the returned item at its sole option. The replacement item may be new or refurbished; if refurbished, it shall be equivalent in operation to new Equipment. If Arcwave replaces a returned item, the Customer agrees that the returned item shall become the property of Arcwave.
- (e) Arcwave shall ship the repaired item or replacement to the Customer's return address by carrier and method of delivery chosen by Arcwave at its cost. If Customer has requested some other form of conveyance, such as express shipping, then the Customer shall pay the cost of return shipment.

NOTE: This publication may include technical inaccuracies or typographical errors. Changes are periodically made to the information herein; these changes will be incorporated in new editions of this publication. Arcwave may make improvements and/or changes in the product(s) described in this publication at any time without notice.

FCC NOTICE: This device complies with Part 15 of the FCC Rules. Operation is subject to the following two conditions: (1) this device may not cause harmful interference, and (2) this device must accept any interference received, including interference that may cause undesired operation.

TM: ARCell, ARCxtend and DBWA are Trademarks of Arcwave, Inc. DOCSIS is a registered trademark of Cable Television Laboratories, Inc. Other product and company names mentioned herein may be the trademarks of their respective owners.

FCC Requirements for Operation in the United States

Radio Frequency Interference Warnings & Instructions

This equipment has been tested and found to comply with the limits for a Class B digital device, pursuant to Part 15 of the FCC Rules. These limits are designed to provide reasonable protection against harmful interference in a residential installation. This equipment uses and can radiate radio frequency energy and, if not installed and used in accordance with the instructions, may cause harmful interference to radio communications.

However, there is no guarantee that interference will not occur in a particular installation. If this equipment does cause harmful interference to radio or television reception, which can be determined by turning the equipment off and on, the user is encouraged to try to correct the interference by one or more of the following methods:

- Reorient or relocate the receiving antenna
- Increase the separation between the equipment and the receiver
- Connect the equipment into an electrical outlet on a circuit different from that which the radio receiver is connected
- Consult the dealer or an experienced radio/TV technician for help

Modifications made to the product, unless expressly approved by Arcwave, Inc. could void the user's right to operate the equipment.

RF Exposure

CAUTION: To ensure compliance with FCC RF exposure requirements, the antenna used for this device must be installed to provide a separation distance of at least 20 cm from all persons and must not be located or operated in conjunction with any other antenna or radio transmitter.

Declaration Of Conformity

We,
Arcwave, Inc.
910 Campisi Way, Suite 1F,
Campbell, CA 95008

declare under our sole responsibility that this product complies with Part 15 of FCC Rules. Operation is subject to the following two conditions:

- This device may not cause harmful interference, and
- This device must accept any interference received, including interference that may cause undesired operation.

Table of Contents

Table of Contents.....	iii
1 System Description.....	1-1
1.1 System Overview.....	1-1
1.2 Frequency Band of Operation.....	1-2
1.3 Range.....	1-3
1.4 CPE Installation.....	1-4
1.5 Access Point Installation.....	1-5
2 Subscriber Installation Details.....	2-1
2.1 Transceiver.....	2-1
2.2 Cable Connection and Grounding.....	2-6
2.3 DC Power Supply.....	2-7
2.4 Wireless Cable Modem.....	2-8
2.5 Frequency Channel.....	2-9
2.6 Modem http Interface.....	2-9
2.7 Installations Close to Access Point.....	2-10
3 Access Point Installation.....	3-1
3.1 Site Survey.....	3-1
3.2 Antenna Patterns.....	3-1
3.3 Frequency Planning – Downstream.....	3-2
3.4 Frequency Planning – Upstream.....	3-7
3.5 Example of Frequency Plan.....	3-9
3.6 Power.....	3-10
3.7 Pipe Mount Installation.....	3-11
3.8 Pole Mount.....	3-13
3.9 Strand Mount.....	3-19
3.10 Verify Service Area.....	3-22
4 Command Line Interface.....	4-1
4.1 Physical Interface.....	4-1
4.2 Command Line Characteristics.....	4-1
4.3 TX Command Line Interface.....	4-2
4.4 RX Command Line Interface.....	4-8

4.5	DX Command Line Interface	4-13
5	Multiples Access Points	5-1
5.1	Frequency Planning.....	5-1
5.2	Mounting & Site Planning	5-1
6	Fault Localization.....	6-1
6.1	Only one user impacted.....	6-1
6.2	Multiple Users Impacted	6-2
6.3	Entire Sector.....	6-2
7	Replacing Failed Access Point	7-1
7.1	Access Point - Strand Mount	7-3
8	Replacing a Failed Subscriber Unit.....	8-1
9	Specifications.....	9-1
9.1	AX1255 ARCXtend Access Point	9-1
9.2	AX3155 Customer Premise Antenna/Transceiver Specifications	9-2
10	Appendix A: Radio Frequency Basics	10-1
10.1	The Electromagnetic Spectrum	10-1
10.2	FCC Rules for use of ISM band.....	10-3
10.3	Line of Sight.....	10-4
10.4	Link Budgeting.....	10-6
10.5	Availability.....	10-7
10.6	Antennas	10-8
10.7	Rain Fade	10-9
10.8	Lightning Strikes	10-11
11	Reader Feedback.....	11-1

1 System Description

The new ARCXtend™ Wireless Plant Extension Solution is the first solution designed from the ground up to seamlessly integrate into a cable operator's network and support infrastructure and cost effectively deliver transparent cable modem service over the air. It is a wireless point-to-multipoint cable plant extension solution operating in the 5GHz license-free band. ARCXtend allows a cable operator to quickly, cost effectively, and reliably satisfy demand for cable modem service in areas where it is too far, difficult, time consuming or expensive to reach with their existing HFC (Hybrid Fiber Coax) network. Cable system operators can now quickly and profitably reach uncovered business, education, government, and commercial customers using Arcwave's field proven, high reliability wireless technology.

ARCXtend is fully interoperable with DOCSIS® compliant Cable Modem Termination Systems (CMTS), Operation Support Systems (OSS), and cable modems enabling cable operators to leverage their existing investment to target the \$200B small and medium business (SMB) services market with a wide range of IP-based services, including IP Telephony, multimedia conferencing, telecommuter services and other multimedia applications without a costly expansion of their HFC plant.

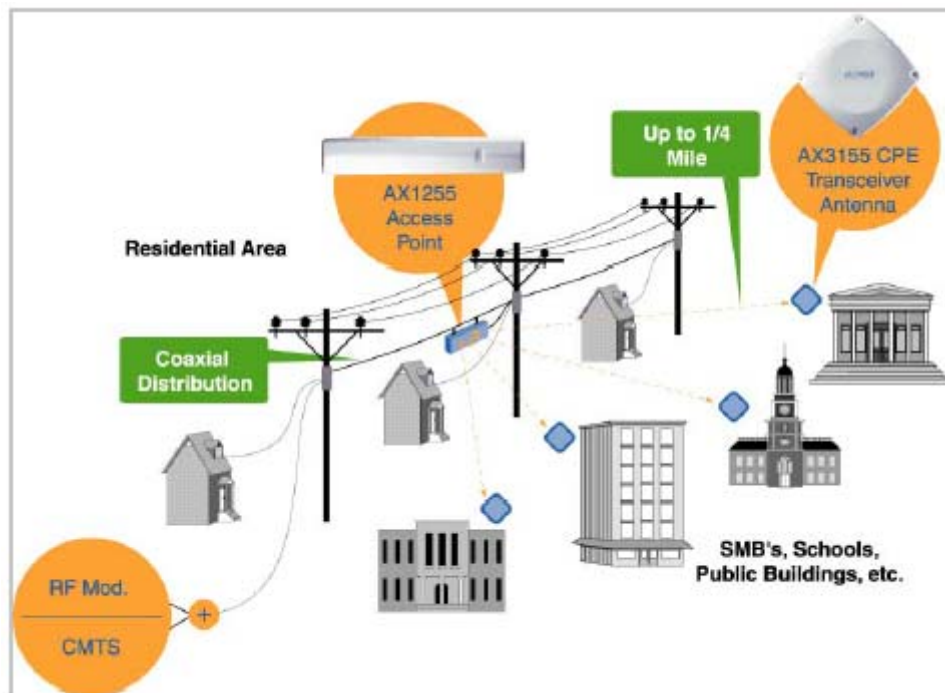

Figure 1-1: ARCXtend System.

Figure 1-1 demonstrates how the ARCXtend system fits into the typical cable system, and delivers service to buildings unreachable by the cable plant.

1.1 System Overview

The ARCXtend 5GHz solution consists of an AX1255 Access Point and one or more AX3155 Subscriber Transceiver/Antennas, as in Figure 1-2.

The AX1255 is a self-contained, weather-protected unit that connects directly to an existing cable plant. It can be pole, wall, or strand mounted, and line or locally powered. It provides up to 2-mile coverage over a 90-degree sector, supports over 30Mbps of downstream bandwidth and can support hundreds of cable modems.

The AX3155 Subscriber Transceiver is a small footprint radome that can be easily mounted on a building or home. It supports delivery of up to 30Mbps of downstream bandwidth to a customer premise. The radome is weather protected and connects directly to a DOCSIS compliant cable modem located at the customer premise.

ARCXtend operates in the un-congested license-free 5.3 GHz and 5.8 GHz bands.

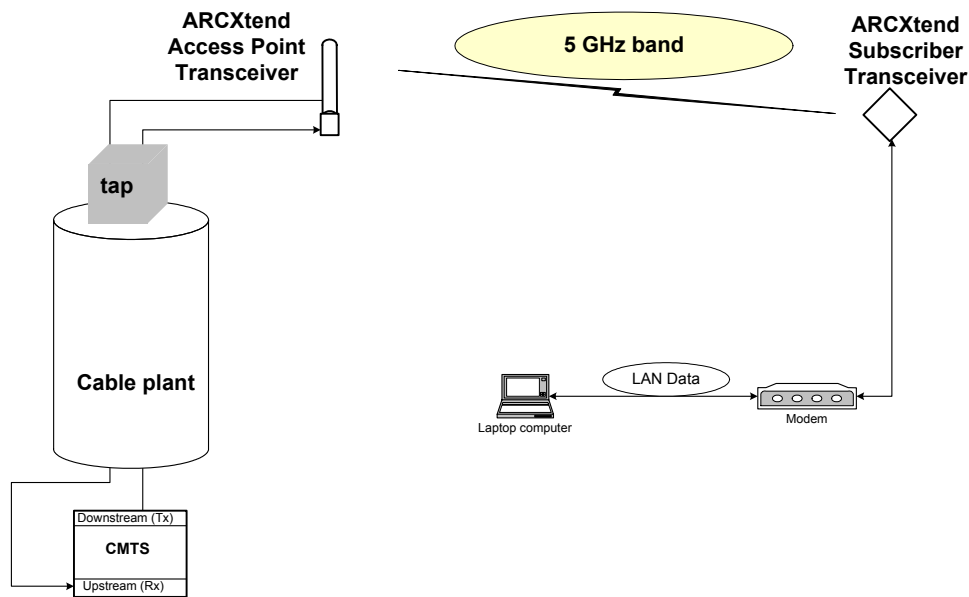

Figure 1-2: Overview of ARCXtend wireless link.

1.2 Frequency Band of Operation

This system operates in the frequency band designated by the FCC as unlicensed and is governed by Part 15 of the FCC Rules and Regulations¹. The components that Arcwave sells comply with these Rules.

This device complies with Part 15 of the FCC Rules. Operation is subject to the following two conditions: (1) this device may not cause harmful interference, and (2) this device must accept any interference received, including interference that may cause undesired operation.

Briefly, the unlicensed rules for digital devices are:

¹ Available at <http://ftp.fcc.gov/oet/info/rules/>.

- Lower band is 5.15-5.35 GHz
 - Transmitted power in the band 5.25 – 5.35 GHz cannot exceed 250 mW.
 - The band 5.15 – 5.25 GHz is for indoor use, and is not used by ARCXtend.
- Upper band is 5.725-5.850 GHz
 - Transmitted power in the band 5.725-5.850 GHz cannot exceed 1 Watt².

Figure 1-2 shows the maximum allowable power out of an amplifier to illustrate the above. Each band has complex rules covering other RF parameters.

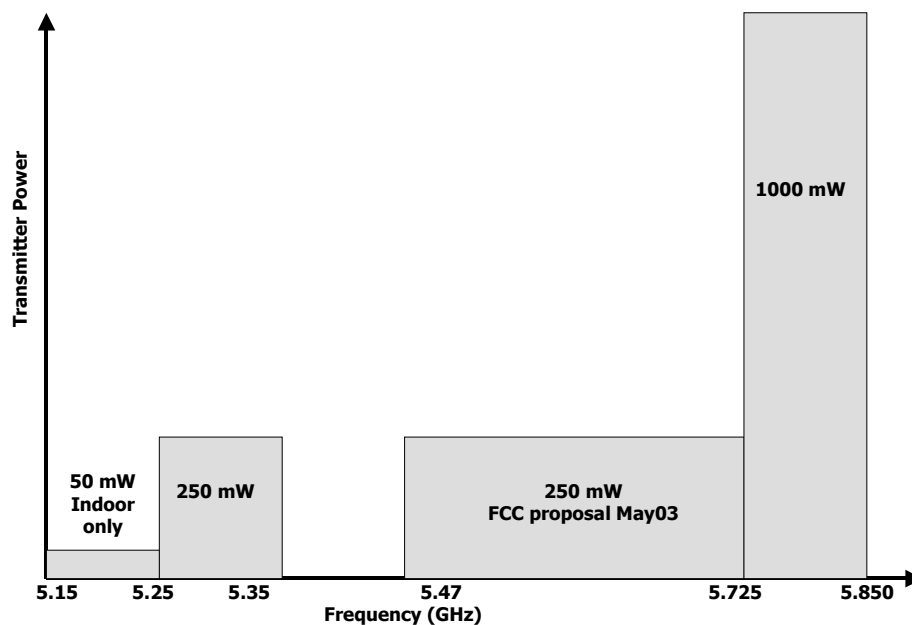

Figure 1-2: Transmitter power limitations set by FCC.

1.3 Range

The ARCXtend's Point-To-Multipoint architecture provides up to 2-mile line-of-sight coverage over a 90-degree sector and supports up to 30Mbps of downstream and 10 Mbps of upstream bandwidth.

² In May 2003 the FCC issued a Notice of Proposed Rule Making (NPRM) to enhance the 5 GHz band. Arcwave is following that NPRM activity and will enhance products as the Rules are finalized.

1.4 CPE Installation

The ARCXtend License-Free, Point-to-Multipoint Wireless Broadband Solution subscriber installation consists of the AX3155 Integrated Subscriber Transceiver mounted on the exterior of the subscriber facility and the Wireless Cable Modem (CM) located inside the structure. A single power and signal cable is run between the Subscriber Transceiver and the modem location. See Figure 1-3.

The Subscriber Transceiver is mounted on a short pipe or bent-arm mounting arrangement similar to a small satellite TV dish, or a light duty non-penetrating flat roof mount. It must be in a position with line of sight to the Access Point Transceiver location. At the time of installation the Subscriber Transceiver is carefully aimed to transmit and receive to/from the Access Point Transceiver.

Later Sections of this manual provide mounting information and grounding recommendations for the Subscriber Transceiver.



Figure 1-3: Photo Subscriber Transceiver.

Inside the Subscriber Location, the CM is connected to the PC by means of a standard Ethernet/LAN cable. Alternatively a LAN hub or switch may be employed between the CM and the PC(s), as the CM has a gateway function that will support up to 75 PCs sharing the modem. A small DC inserter device is connected between the CM and the lead to the outdoor unit. The inserter and most modems each have cord mounted power supplies.

1.5 Access Point Installation

The multipoint Access Point has two installation options: pole mount and strand mount.

The pole mount option is designed to be placed on a utility pole, as in Figure 1-4, connected to the cable system tap. It is normally powered from the tap as well, but other options are available.

The strand-mount option is designed to be suspended from a wire strand between two utility poles, as in Figure 1-5. It is also normally powered from the tap.



Figure 2-4: Pole-mounted Access Point.

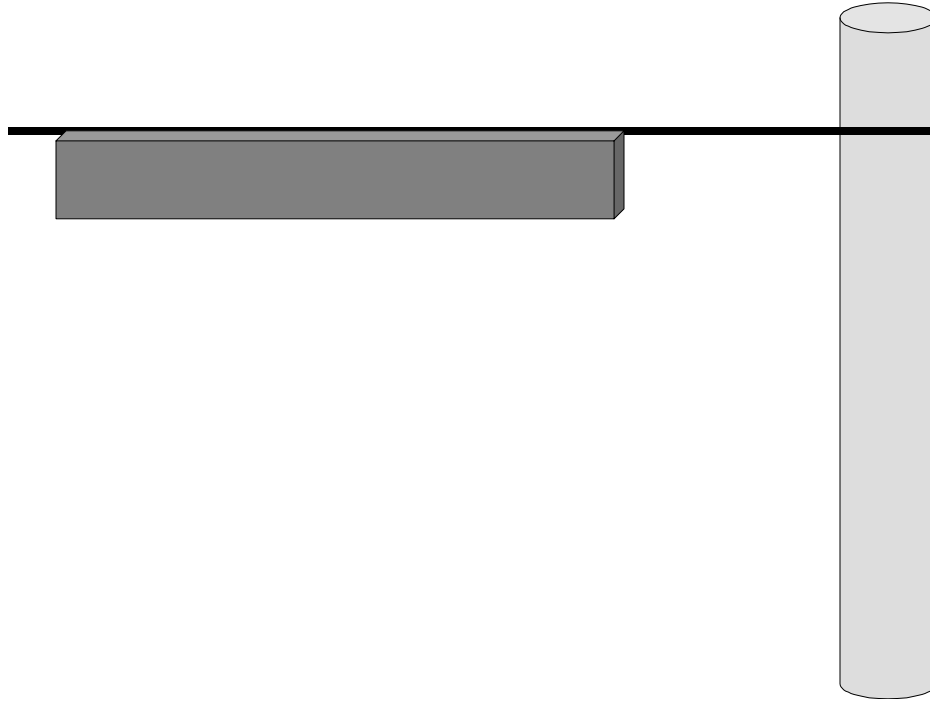

Figure 1-5: Strand-mounted Access Point.

2 Subscriber Installation Details

Installation at the subscriber's site is very simple – one small outdoor unit (the transceiver) and one cable modem indoors. Power for the outdoor unit is carried over the TV-type coaxial cable between the two units.

Frequency of operation, RF power, etc. are all determined automatically. There are no settings to be made on site. The installation diagram is in Figure 2-1.

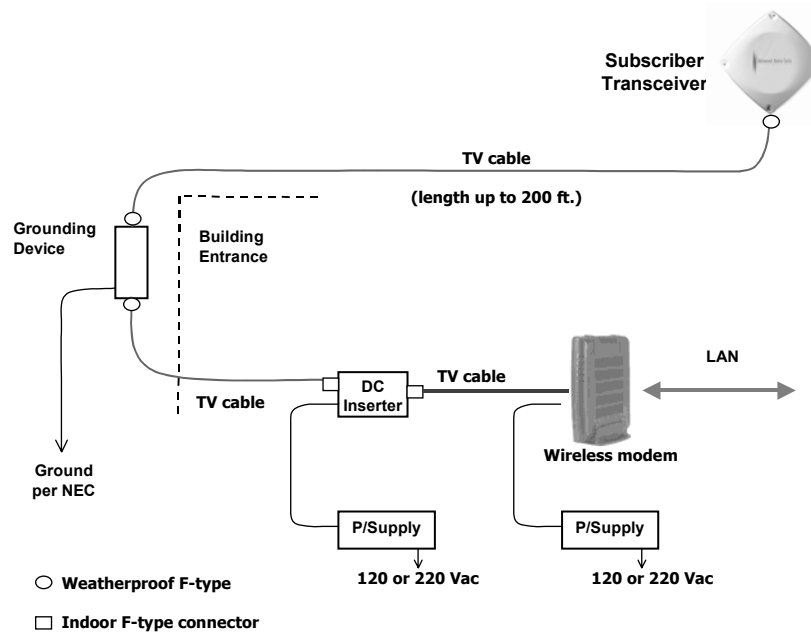

Figure 2-1: Schematic diagram subscriber installation.

2.1 Transceiver

The Subscriber Transceiver contains a transmitter, a receiver and the antenna, all in one integrated weatherized unit that is about 1x1 foot square, as in Figure 2-2.

2.1.1 Mounting

Mount the Subscriber Transceiver on a vertical pipe with at least 12 inches clear of any hardware or other impediments. The mounting brackets will accommodate pipe outside diameter (OD) from 1.25 to 2 inches. The front face of the antenna must point in the direction of the Access Point.



Figure 2-2: Subscriber Transceiver pointing towards Access Point.

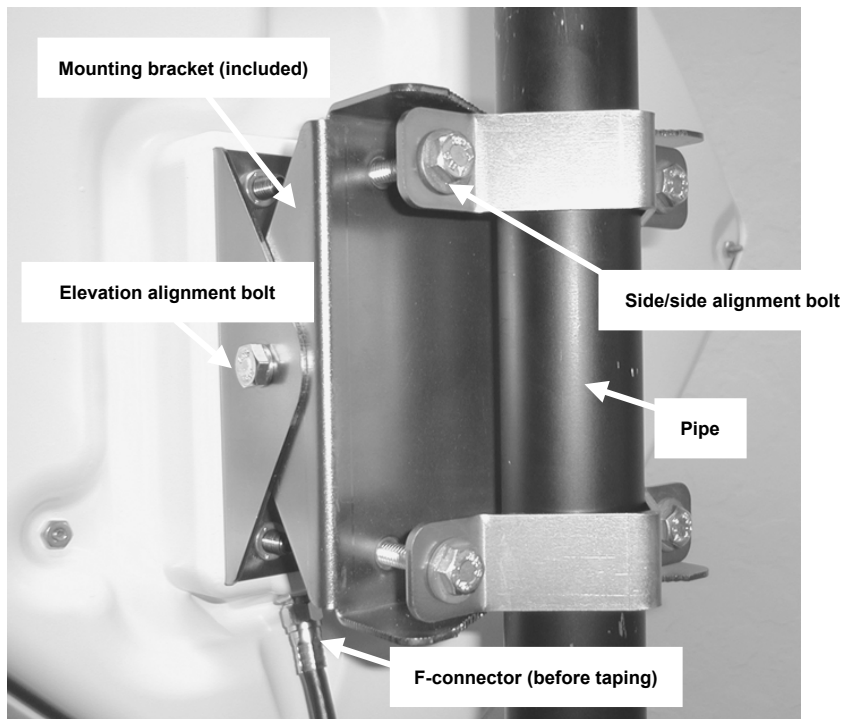

Figure 2-3: Subscriber Transceiver mounted on pipe.

2.1.2 Subscriber Transceiver Alignment Methods

There are three recommended methods for aligning the Subscriber Transceiver for maximum performance:

1. Arcwave Signal Strength Meter
2. Dedicated modem signal meter
3. Spectrum analyzer
4. Channel-selectable cable-TV meter.

They are described below.

All devices are used to measure the downstream signal level received from the base station. By optimizing the downstream, the upstream is optimized automatically.

Once the particular alignment equipment is chosen, and connected to measure the downstream signal level (receive), the Subscriber Transceiver is peaked as follows:

1. Using a 7/16" wrench (open end, box or socket), loosen the two elevation alignment bolts until the Transceiver can be tilted up or down by hand, but will hold its position.
2. Observe the display of the alignment device being employed and orient the Transceiver up and down to achieve a maximum peak signal. There may be other smaller peaks, but the main one should be evident.
3. Tighten the elevation alignment bolts slightly.
4. Using the same wrench loosen the four mounting bolts so the transceiver can be oriented side to side by hand.
5. Observe the display of the alignment device being employed and orient the transceiver side to side to achieve a maximum peak signal. There may be other smaller peaks, but the main one should be evident.
6. Tighten the elevation alignment bolts slightly.
7. Repeat the elevation (up or down) adjustment, and then the azimuth (side by side) adjustment once again.
8. Tighten the elevation alignment (tilt) bolts, taking care not to over tighten.
9. Tighten the mounting bolts firmly, but do not over tighten as that simply bends the mounting brackets.
10. Remove the measurement equipment and connect the modem cable.
11. Tape the F-type connector to protect it from weather.
12. Verify the modem's link to the CMTS is operating properly.

The three pieces of measurement equipment are discussed below.

2.1.3 AR100 Signal Strength Meter

The Arcwave AR100 Signal Strength Meter (SSM), shown in Figure 2-4, is a small hand held device that is temporarily inserted between the Transceiver end of the coaxial cable down lead and the Transceiver itself, as in Figure 2-5.



Figure 2-4: AR100 Signal Strength Meter (SSM).

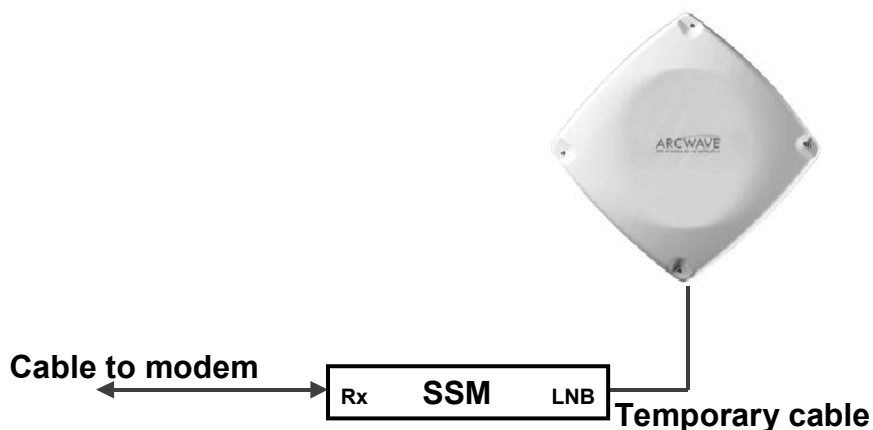

Figure 2-5: AR100 Signal Strength Meter (SSM) at transceiver.

Connect the coax cable from the indoor power inserter to the SSM "Rx" port and a temporary short coax jumper from the SSM "LNB" port to the Transceiver. The SSM and the Transceiver will then be powered from the power inserter³.

Align the Transceiver by peaking the signal on the SSM's meter, adjusting the sensitivity control on the SSM as needed.

Note that the AR100 SSM is a very broadband device that responds to energy below 500 MHz. It will "see" all energy from few hundred MHz to at least 1900 MHz, and

³ The external power jack on the SSM is unused.

thus can be spoofed by a stray signal near the Transceiver and SSM. The AR100 is a modified Triplet SatAlign SSM.

2.1.4 Sencore DSL757

The Sencore DSL757 Digital Director (www.sencore.com) is a dedicated test device to meter cable signal levels. One of its basic modes is to display on its LCD screen the received signal level.

Connect a temporary 2-way splitter to the Subscriber Transceiver and then connect the Sencore meter to the splitter.. Align the Transceiver by peaking the signal on the display.

Remove the splitter and connect the modem's cable to the transceiver. Tape the F-connector to protect it from the weather.

2.1.5 Spectrum Analyzer

Connect the spectrum analyzer, such as Anritsu MS2711B of Figure 2-6, via a temporary 2-way splitter at the transducer.



Figure 2-6: Anritsu MS2711 portable spectrum analyzers.

Adjust the spectrum analyzer to display the downstream IF signal from the Subscriber Transceiver (which will be between 425 and 550 MHz). Reduce the frequency span and adjust the amplitude to achieve a trace similar to the one in Figure 2-7.

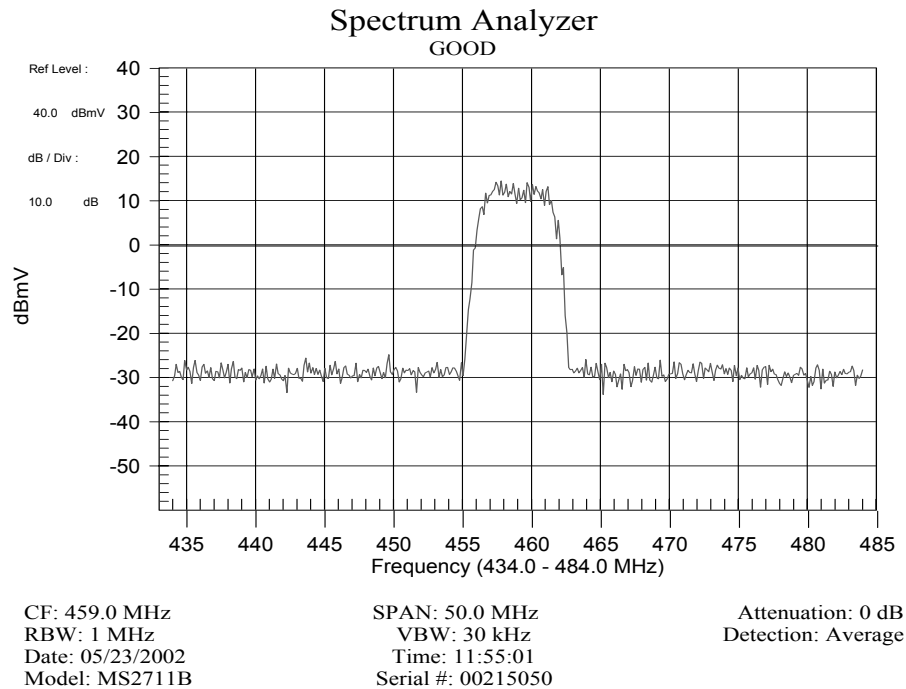

Figure 2-7: Proper Downstream IF input to subscriber's modem.

The spectrum analyzer settings for Figure 2-7 are shown in Table 2-1:

Table 2-1: Typical spectrum analyzer settings.

Parameter	Setting
Center Frequency	459 MHz
Span	50 MHz
RBW	1 MHz
VBW	30 kHz
Vertical Scale	linear, 10 dB / division
Reference Level	+40 dBmV
Attenuation	20 dB
Detection Mode	Averaging

Align the subscriber Transceiver antenna as described above, adjusting for maximum signal amplitude.

2.2 Cable Connection and Grounding

Attach the single RG-6 coaxial cable to the F connector on the rear of the Subscriber Transceiver. See Figure 2-8. Waterproof the connection using a suitable method such as taping with Scotch #88. Be sure to leave sufficient slack to allow the

antenna to be oriented and that the cable runs directly downward from the connector to avoid water running down the cable and into the F connection.

Route the coaxial cable to the building entry point utilizing UV-resistant tie-wraps and staples or cable clamps as required.

UV-rated cable should be used outdoors, and Riser-rated cable can be used indoors. In some buildings, a Plenum-rated or riser-rated cable is required. Consult the local codes.

Mount the grounding device in Figure 2-8 (e.g. Radio Shack 15-909C) as near as practicable to the point of cable entry to the structure. Connect the grounding device to a suitable “grounding electrode” following local code.⁴ Connect the RG-6 coaxial cable from the Subscriber Transceiver to the grounding device and waterproof all outdoor-rated F connectors, such as by wrapping them with tape.

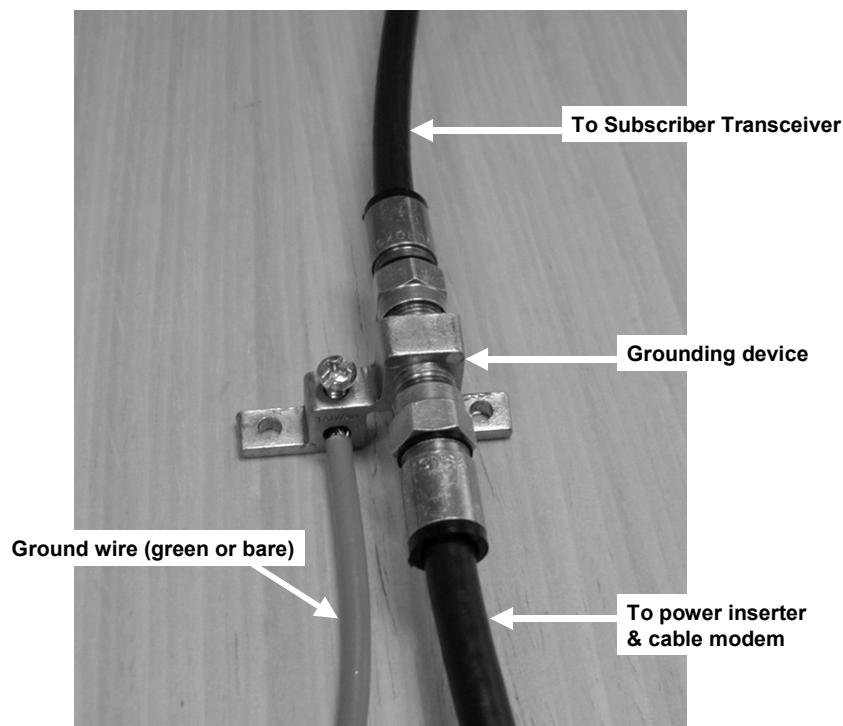

Figure 2-8: Typical grounding device at subscriber premises.

2.3 DC Power Supply

The Transceiver is powered over the coaxial cable via a Power Inserter (Figure 2-9) provided with the Transceiver.

Inside the CPE building, route the RG-6 from the building entrance point to the wireless cable modem location. Install an F connector on the cable. Connect the transceiver cable to the “To Antenna” F-type female connector of the Power Inserter.

⁴ For example, the National Electric Code, sections 820-33 and 820-40, describes this requirement in detail.

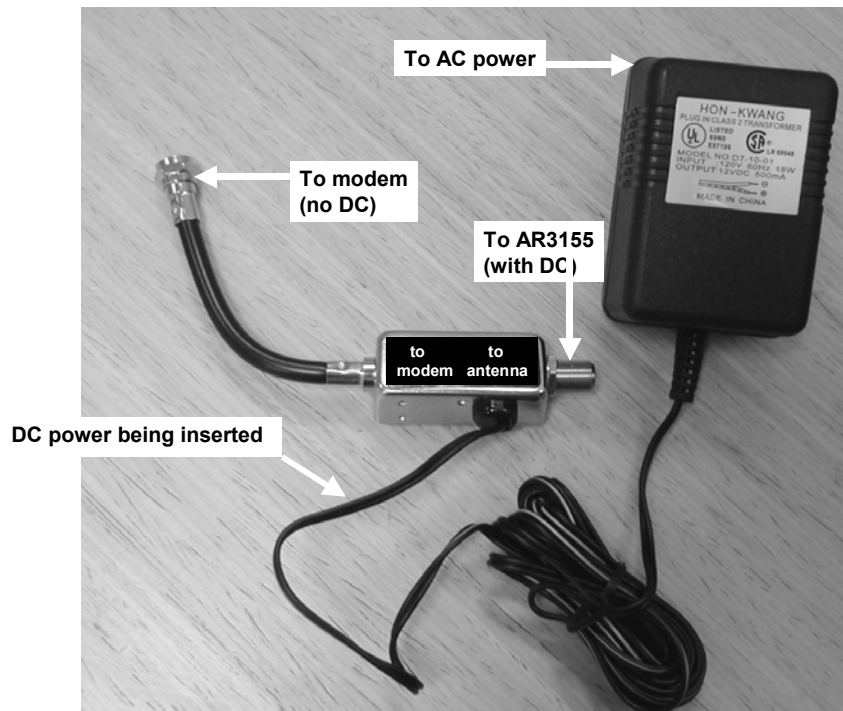

Figure 2-9: Power Inserter and AC/DC converter.

2.4 Wireless Cable Modem

Place the wireless cable modem where it will be used and attach the short cable on the power inserter (labeled “To Modem” in Figure 2-9) to the F connector on the rear of the modem. Connect the (separate) modem wall-mounted power supply (included with the wireless cable modem) to the power connector on the rear of the modem. Plug both wall mounted power supplies into suitable AC power sources – preferably a UPS or surge protected power strip. Connect a straight-through 10/100BaseT LAN cable between the RJ-45 jack on the modem and the user hub, router or personal computer.

Figure 2-10 illustrates the modem connections at the back of a typical modem. The DB-9 connector is a maintenance port for the modem shown.

The CM, when it is first powered up or when it has lost the downstream signal, will “step” through the standard EIA channel list looking for the downstream signal. Alternatively, the CM may be optioned through its administrator interface to lock onto a specific downstream frequency.

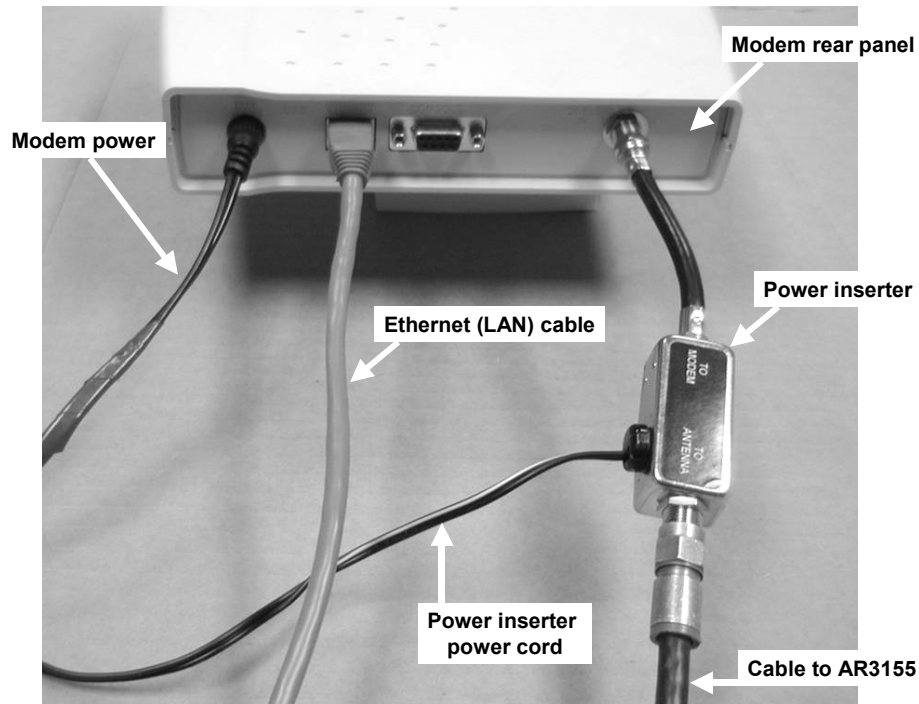

Figure 2-10: Rear view of typical wireless cable modem.

2.5 Frequency Channel

The cable modem will automatically search for the active channels, will go through a handshake with the CMTS, will be told all the parameters it will need to join the wireless network and will be authenticated/authorized to join.

2.6 Modem http Interface

The modem status can be determined by the LEDs and by a browser interface.

The typical modem LEDs and their use are:

Power: ON = power OK

Cable: ON = ranged & registered with CMTS, blinking= in process

LAN: ON = connected

USB: ON = connected [some modems have both USB & LAN connectors]

Activity: blinking = data (transmit or receive)

The browser interface is available on some modems and contains more information.

The typical instructions in the user manual are to follow these steps:

Connect a PC to either the modem's USB or the Ethernet interface

Launch the PC's browser, such as Microsoft's Internet Explorer

Address: <http://192.168.100.1>

User: (leave this blank)

Password: cable

The typical modem screen looks like Figure 2-11.

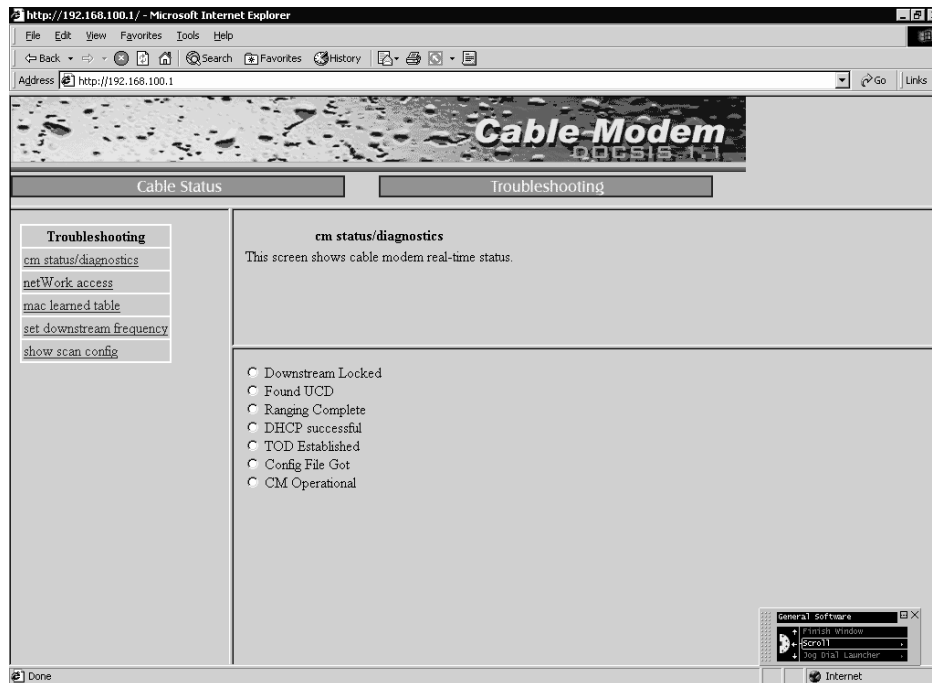

Figure 2-11: Screen for cable modem status.

2.7 Installations Close to Access Point

Subscriber installations that are very close to the Access Point may have a situation where the input to the cable modem is overloaded. An overloaded input usually causes lack of synchronization and/or a high error count. If this is suspected, try a 6, 10 or 20 dB pad/attenuator at the modem input and see if the modem starts to lock and be error free. If so, leave the pad in place.

The subscriber installation Schematic Diagram (Figure 2-13) shows a “Pad” installed between the power inserter and the wireless cable modem (the “dry” side of the power inserter). Small pads of many values are available with F-type connectors to screw in-line with the coaxial cable connection, such as Channel Visions #3000-10. Figure 2-12 also shows the recommended UPS that most customers already have for their router and other LAN equipment.

At the time of system set-up it may be determined that such pads are required in subscriber installations extremely close (less than a mile) from the Access Point site to reduce excess downstream signal.

A spectrum analyzer is another way to check symptoms of overloading.

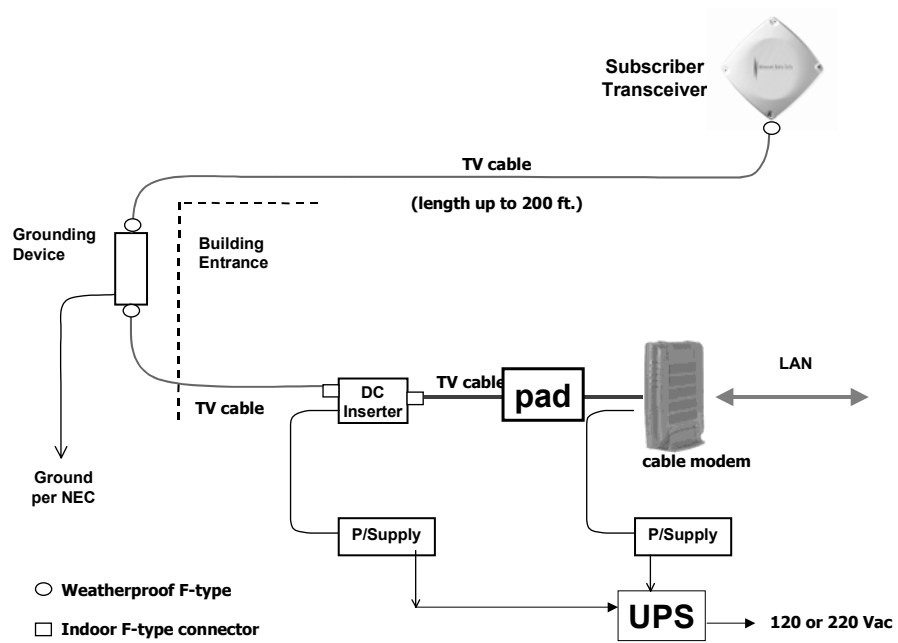

Figure 2-12: Adding pad to eliminate overload.

3 Access Point Installation

The Access Point is installed at a point on the cable system plant where it can reach a number of customers.

3.1 Site Survey

Paper records of what is at a specific site are notoriously poor, so it is always best to preview the installation by visiting the site.

3.1.1 Physical plant

A decision has to be made about mounting the Access Point Transceiver. It can be mounted on a utility pole or on a wire strand.

Another factor to plan is the powering – will it be powered from the coaxial cable tap, or from the local utility AC.

The tap has to be found that will serve the Access Point. Some coaxial cable may be needed to extend the tap a few feet to reach the Access Point's planned location.

The Access Point should be located so it has the best line-of-sight coverage of the desired customer area.

Grounding the Access Point must be planned to minimize damage from lightning surges and accidental power crosses to the coaxial cable plant.

3.1.2 5 GHz Usage

The RF must also be planned. Usually the 5 GHz band is lightly used, since microwave ovens, cordless phones, etc. do not generally use this band. If, however, the band is already heavily used, then a survey with a spectrum analyzer is the best way to determine which channel to use to reach the customers.

3.2 Antenna Patterns

Each Access Point Transceiver has a built-in antenna, with the strongest power straight out from the antenna's axis. The antenna's axis is perpendicular to the radome covering it.

Elevations above straight out from the front of the antenna (up into the sky) receive less power, as do elevations below straight out. Therefore, the antenna is normally pointed at the furthest subscriber to be served, with the lower elevations providing appropriately less power to closer subscribers. This pointing is usually referred to as "downtilt". Most installations do not require a downtilt.

The Access Points are available in two basic models, one designed for vertical mounting and the other for horizontal mounting. They differ in antenna polarization and mounting hardware. The descriptive model name is Strand Mount and Pole Mount. In both mounts, the resulting transmitted signal is vertically polarized when it leaves the Access Point.

3.3 Frequency Planning – Downstream

This Section describes some of the issues involved in planning a wireless network deployment.

The ARCell wireless system uses different frequencies for Downstream (Access Point to subscriber) and Upstream (subscriber to Access Point) communications, which is referred to as a Frequency Division Duplex (FDD) system.

The Downstream uses a channel within the unlicensed 5 GHz “high” band, 5.725-5.850 GHz. Upstream uses a channel within the “low” band, 5.250-5.350 GHz.

To cover a large metropolitan area, some pre-planning is needed for the use of the right channels at each location.

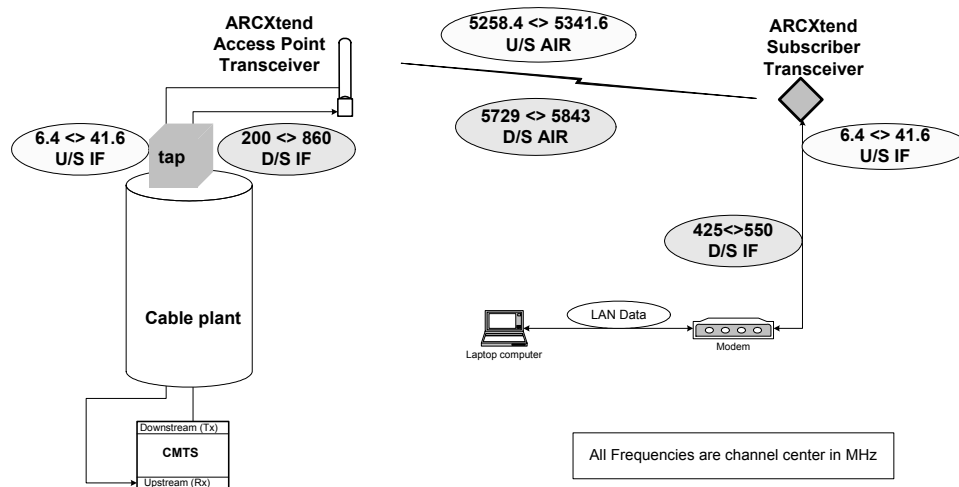

Figure 3-1: Frequency Plan.

Figure 3-1 illustrates the range of frequencies:

- The Figure shows that Downstream be any frequency in the range 200 to 860 MHz. This is usually the frequency used by the wired modems.
- The Access Point Transmitter modulates this channel to the 5.8 GHz band..
- The Subscriber Receiver Downconvert 5.8GHz signal to the 425-550 MHz IF, which is a standard CATV channel the modem can detect.
- The modem hunts for this channel and the DOCSIS protocol. This IF frequency is often different from the CMTS downstream frequency.

- e) Going in the Upstream, the modem output (transmit) upstream is whatever the CMTS configuration has instructed, which is in the range of 6.4 to 41.6 MHz.
- f) The Subscriber Transmitter (inside the CPE Transceiver) up-converts this IF channel to the 5.3 GHz band, which goes over the air to the Access Point Receiver. The RF transmission is scheduled by the DOCSIS protocol, so that it does not interfere with other modem transmission on this channel.
- g) The Access Point Receiver tuned to 5.3 GHz band, down-converts this to the upstream channel 6.4 to 41.6 MHz.
- h) The CMTS Upstream port detects the 6.4-41.6 MHz upstream signal.

Table 3-1: EIA Channel numbers and Downstream Center Frequency

EIA CATV Channel	CATV Video Edge	AX Center 6MHz	EIA CATV Channel	CATV Video Edge	AX Center 6MHz	EIA CATV Channel	CATV Video Edge	AX Center 6MHz
23	217.25	219	59	433.25	435	102	661.25	663
24	223.25	225	60	439.25	441	103	667.25	669
25	229.2625	231	61	445.25	447	104	673.25	675
26	235.2625	237	62	451.25	453	105	679.25	681
27	241.2625	243	63	457.25	459	106	685.25	687
28	247.2625	249	64	463.25	465	107	691.25	693
29	253.2625	255	65	469.25	471	108	697.25	699
30	259.2625	261	66	475.25	477	109	703.25	705
31	265.2625	267	67	481.25	483	110	709.25	711
32	271.2625	273	68	487.25	489	111	715.25	717
33	277.2625	279	69	493.25	495	112	721.25	723
34	283.2625	285	70	499.25	501	113	727.25	729
35	289.2625	291	71	505.25	507	114	733.25	735
36	295.2625	297	72	511.25	513	115	739.25	741
37	301.2625	303	73	517.25	519	116	745.25	747
38	307.2625	309	74	523.25	525	117	751.25	753
39	313.2625	315	75	529.25	531	118	757.25	759
40	319.2625	321	76	535.25	537	119	763.25	765
41	325.2625	327	77	541.25	543	120	769.25	771
42	331.275	333	78	547.25	549	121	775.25	777
43	337.2625	339	79	553.25	555	122	781.25	783
44	343.2625	345	80	559.25	561	123	787.25	789
45	349.2625	351	81	565.25	567	124	793.25	795

46	355.2625	357	82	571.25	573	125	799.25	801
47	361.2625	363	83	577.25	579	126	805.25	807
48	367.2625	369	84	583.25	585	127	811.25	813
49	373.2625	375	85	589.25	591	128	817.25	819
50	379.2625	381	86	595.25	597	129	823.25	825
51	385.2625	387	87	601.25	603	130	829.25	831
52	391.2625	393	88	607.25	609	131	835.25	837
53	397.2625	399	89	613.25	615	132	841.25	843
54	403.25	405	90	619.25	621	133	847.25	849
55	409.25	411	91	625.25	627	134	853.25	855
56	415.25	417	92	631.25	633			
57	421.25	423	93	637.25	639			
58	427.25	429	94	643.25	645			
			100	649.25	651			
			101	655.25	657			

3.3.1 Available Channels

There are 18 available downstream 6 MHz channels in the ARCXtend standard 5.725-5.850 GHz band.

Table 3-1: Downstream Air Center Frequencies

Downstream Air Transmit Center Frequency (MHz)
5729
5735
5741
5747
5759
5765
5771
5777
5783
5789
5795
5807

5813
5819*
5825*
5831*
5837*
5843*

NOTE: 5753 and 5801 MHz are not used.

At the CPE, the downstream 5.8 GHz frequency is translated into an intermediate frequency (IF) that the cable modem hunts to and locks on, as in Table 3-2.

Table 3-2: Downstream Frequency Plan at CPE

Downstream Receive (from the air)	Modem IF Input (from CPE transceiver)	Modem Channel
Center freq. (MHz)	Center freq. (MHz)	EIA TV Channel #
5729	429	58
5735	435	59
5741	441	60
5747	447	61
5753	453	62
5759	459	63
5765	465	64
5771	471	65
5777	477	66
5783	483	67
5789	489	68
5795	495	69
5801	501	70
5807	507	71
5813	513	72
5819*	519	73
5825*	525	74
5831*	531	75
5837*	537	76
5843*	543	77

Downstream air frequencies 5819 MHz through 5843 MHz are not yet FCC approved.

3.3.2 Downstream Adjacent 90-degree Sectors

The 90-degree-Sector Transceiver has a half-power horizontal beam width of 90 degrees, i.e., 45 degrees each side of center, call the “bore sight” of the antenna. But, the energy of the antenna does not simply cut off at 45 degrees in horizontal pattern from the centerline of the antenna. Rather, the energy falls off as the angle from the centerline increases. A typical antenna pattern is shown in Section on Basic RF.

This means that a subscriber in the vicinity of 45 degrees clockwise from antenna A will also be in the vicinity of 45 degrees counterclockwise from adjacent antenna B. Subscribers in the overlap zone – especially if they are relatively close to the Access Point – will receive downstream signals from both adjacent Access Point Transceivers. This will cause unacceptable interference if both Access Point Transceivers are transmitting on the same frequency, even though the subscriber is receiving nominally the same signal from both Access Point Transceivers.

The solution for this is to ensure that adjacent Access Point Transceivers are never transmitting on the same frequency. Two downstream frequencies (A & B) are required for an omnidirectional system employing 4x90-degree Access Point Transceivers. Figure 3-2 shows the recommended ABAB pattern.

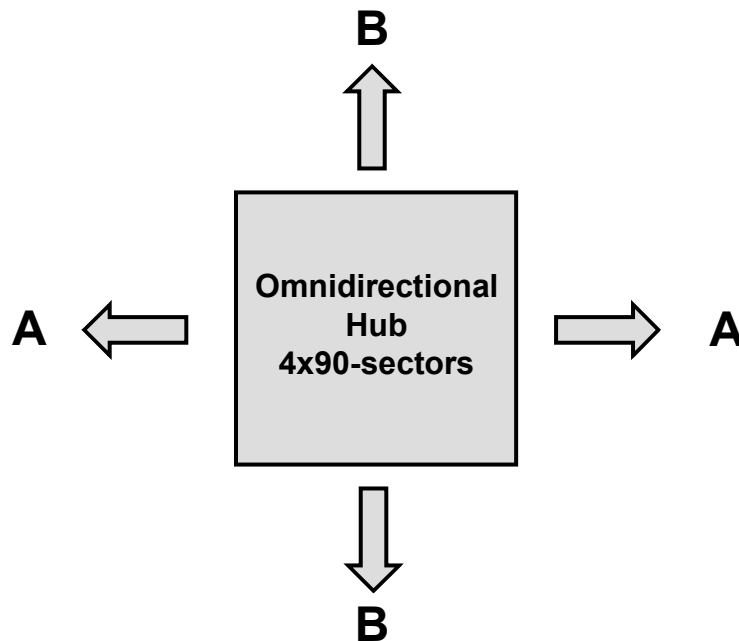

Figure 3-2: Downstream Channel Example of ABAB.

3.3.3 Downstream Logical Channels

It is important to note the distinction between “downstream frequencies” and “downstream logical channels”. The “downstream frequencies” (A & B) discussed above refer to the actual RF carrier frequencies transmitted over the air. “Downstream logical channel” refers to the downstream data stream at the output of a base station CMTS downstream module. In the examples here, the frequencies employed may be driven from one to two downstream logical channels. The difference lies in the traffic capacity of the Access Point.

For example, Figure 3-3, below, illustrates a 4-sector system that utilizes the ABAB downstream frequency pattern for one downstream logical channel, which is split ultimately to all four sectors. This system has an aggregate raw downstream capacity of 31 Mbps downstream using 64QAM modulation.

The same Figure 3-3 has two Upstream air frequencies in an XYXY pattern which can be mapped into one or two upstream cable channels discussed in the next section.

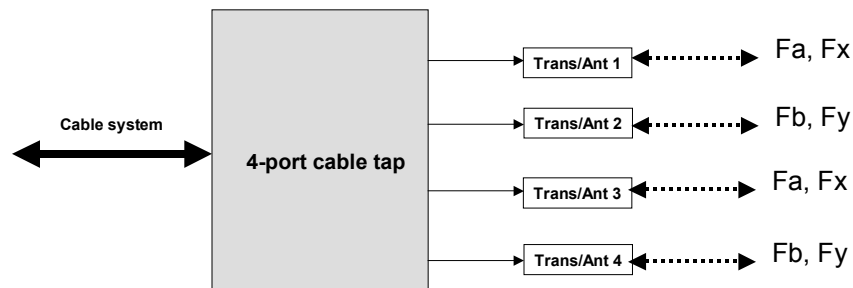

Figure 3-3: Four-Sector ABAB System with 1 downstream data stream.

3.4 Frequency Planning – Upstream

This Section discusses several issues related to planning the use of the frequency band for Upstream communications.

3.4.1 Upstream Logical Channels

It is important to recall that any given downstream logical channel may have a large number of upstream logical channels associated with it, and that any given upstream

is always associated with one and only one downstream. The association of one or more upstream logical channel with a downstream logical channel is made in the CMTS configuration. Upstream logical channels from one or more Access Point Transceivers may not be combined into a single upstream input to the CMTS.

3.4.2 Upstream Frequencies

The cable modem at the customer site obeys the various protocols within the cable plant. One of these determines the frequency that the cable modem operates on for both upstream and downstream.

The CPE Transceiver modulates the modem upstream output and puts it over the air in the 5.3 GHz ISM band as a double-sideband signal. The Access Point Receiver is tuned to one of the carriers. The AP Receiver demodulates the received frequency down into the same cable frequency the modem transmitted, and places it on the cable system.

3.4.3 Available Frequencies

All wireless modems in the same Access Point sector must transmit upstream on the same frequency, and each wireless modem can operate on only one upstream channel.

The Upstream data rate is 5.12 Mbps with Channel Bandwidth of 3.2 MHz.

Table 3-2 shows the modem Upstream frequencies, and the corresponding Upstream Air frequency used by the subscriber transducer.

The CMTS commands the wireless modem to its Upstream Transmit Carrier frequency during the wireless modem registration process. These are configuration parameters that are set in the CMTS network management system. See the software installation guide for that product.

Some operators combine multiple Upstreams from different nodes. This may dictate the upstream channel for the wireless modems. Combining Upstreams tends to save on capital equipment, but will limit the traffic that can be carried. This balance of cost/performance tradeoff is usually different for business customers than residential customers.

Table 3-2: Upstream Frequency Plan⁵

Modem US & Cable System US Channel	Upper Carrier CPE air Tx & Access Point Rx	Lower Carrier CPE air Tx & Access Point Rx
center (MHz)	center (MHz)	center (MHz)
f_{ch}	$5300 + f_{ch}$	$5300 - f_{ch}$
6.4	5306.4	5293.6
9.6	5309.6	5290.4
12.8	5312.8	5287.2
16.0	5316.0	5284.0
19.2	5319.2	5280.8
22.4	5322.4	5277.6
25.6	5325.6	5274.4
28.8	5328.8	5271.2
32.0	5332.0	5268.0
35.2	5335.2	5264.8
38.4	5338.4	5261.6
41.6	5341.6	5258.4

This mapping of the modem upstream channel to the over-the-air 5.3 GHz channels (double sideband modulation) is fixed. Should interference or other factors force the choice of a specific 5.3 GHz channel, the Access Point Receive Frequency should be flipped to the alternate frequency. This is done through the Access Point control interface.

3.5 Example of Frequency Plan

The system in Figure 3-4 is an example of a frequency plan at one Access Point.

The CMTS Downstream is EIA Channel 93 (639 MHz) for wired and wireless modems.

The ARCxtend Access Point is programmed to convert this into a Downstream air frequency of 5777 MHz (the programming is covered in a later Section).

⁵ A spectrum analyzer looking at the subscriber's transmitted RF will see two frequencies. The two carriers are 5300 MHz +/- the upstream IF frequency. The Hub receiver is tuned to only one of these two frequencies.

The ARCXtend CPE Transceiver converts the 5777 MHz to 477 MHz.

The cable modem locks onto the 477 MHz DS signal, handshakes with DOCSIS, and it is instructed to use an upstream of 12.8 MHz.

The CPE Transceiver converts the 477 MHz to 5287.2 & 5312.8 MHz and transmits these over the air to the Access Point.

The Access Point is configured to receive only the 5287.2 MHz and is configured to convert it to 12.8 MHz Upstream, which goes into the tap.

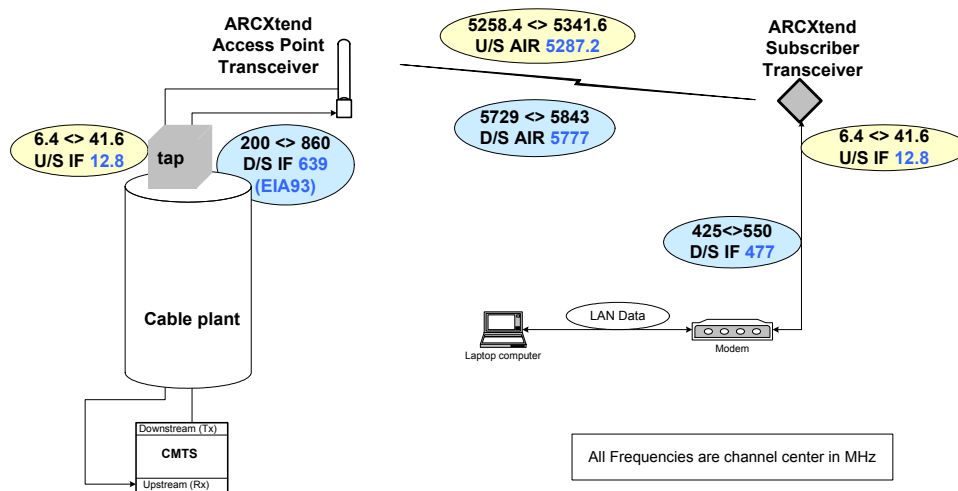

Figure 3-4: Example of a frequency plan.

3.6 Power

The Access Point has a few power options. The choice is usually made during the site survey. The choices are:

- Cable powered
- Local utility power

3.6.1 Cable Powered

The most common powering is via the power on the coaxial cable itself.

The CATV industry AC power is normally square-wave 60-90 Vac, 60 Hz.

Another Access Point model can be powered from DC on the coax. It can be powered with 8-24 Vdc. If the cable system doesn't have the dc, a coaxial DC inserter can be used.

3.6.2 Local Utility Powered

Other powering is possible, using external converters from whatever the local utility provides, into DC, 8-24 Vdc. This is connected to the Access Point power connector.

In this application, the cable system tap passes only RF.

3.7 Pipe Mount Installation

The Access Point Mast Mount Kit is designed to mount the AP on a pipe.

The pipe size should be between 1.5 and 2.25 inches, outside diameter (OD).

The cable goes out the bottom of the Access Point.

The pipe can be mounted on a building roof, side of a building, side of a tower, or on a utility pole.

Figure 3-5 shows the weather cover as a rear view of the Access Point on a pipe.

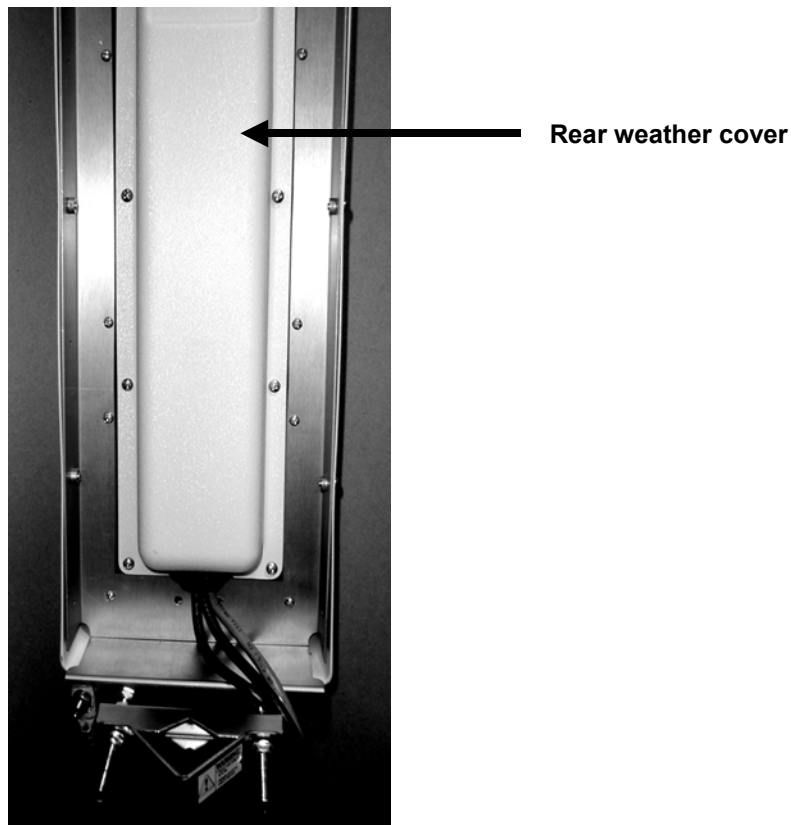

Figure 3-5: Access Point mounted on pipe.

Figure 3-6 shows the pipe mounting kit pieces. There are two such bracket pairs in the Mounting Kit.

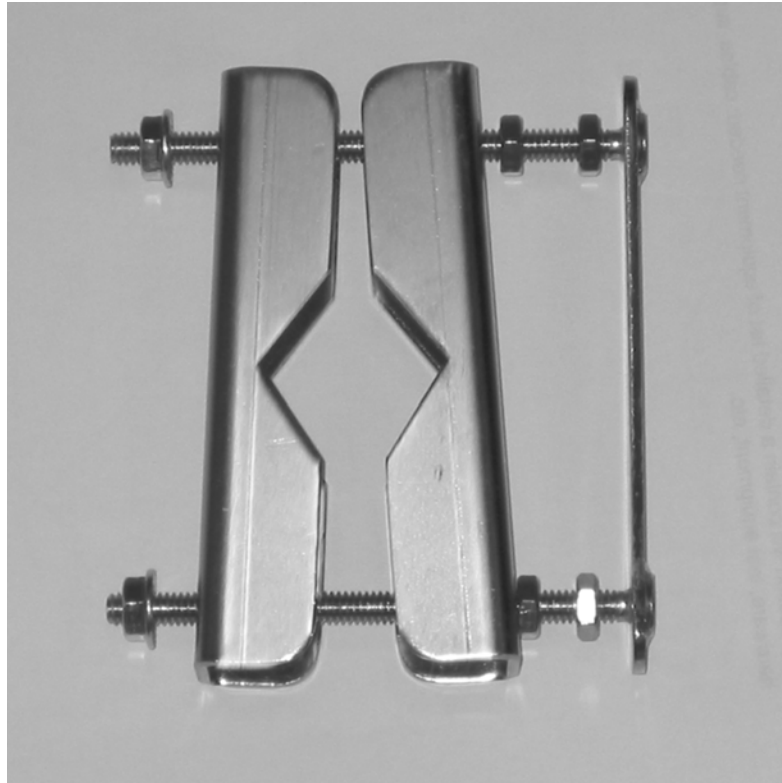

Figure 3-6: Pipe mounting kit (1 of 2)

Figure 3-7 shows the detail of the cable coming out of the bottom of a pipe-mounted Access Point.

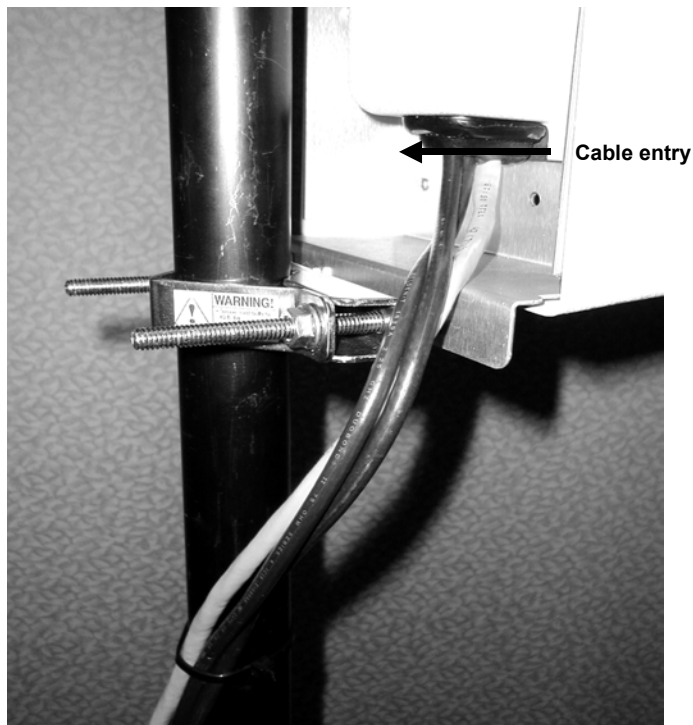

Figure 3-7: Access Point Cable Installation detail.

3.8 Pole Mount

The decision of pole mount vs. strand mount is totally governed by local practices. Some administrations prefer one over the other based on cost, tariffs, access, etc. Figure 3-8 and 3-9 show the pole details of the Pole Mount Kit.

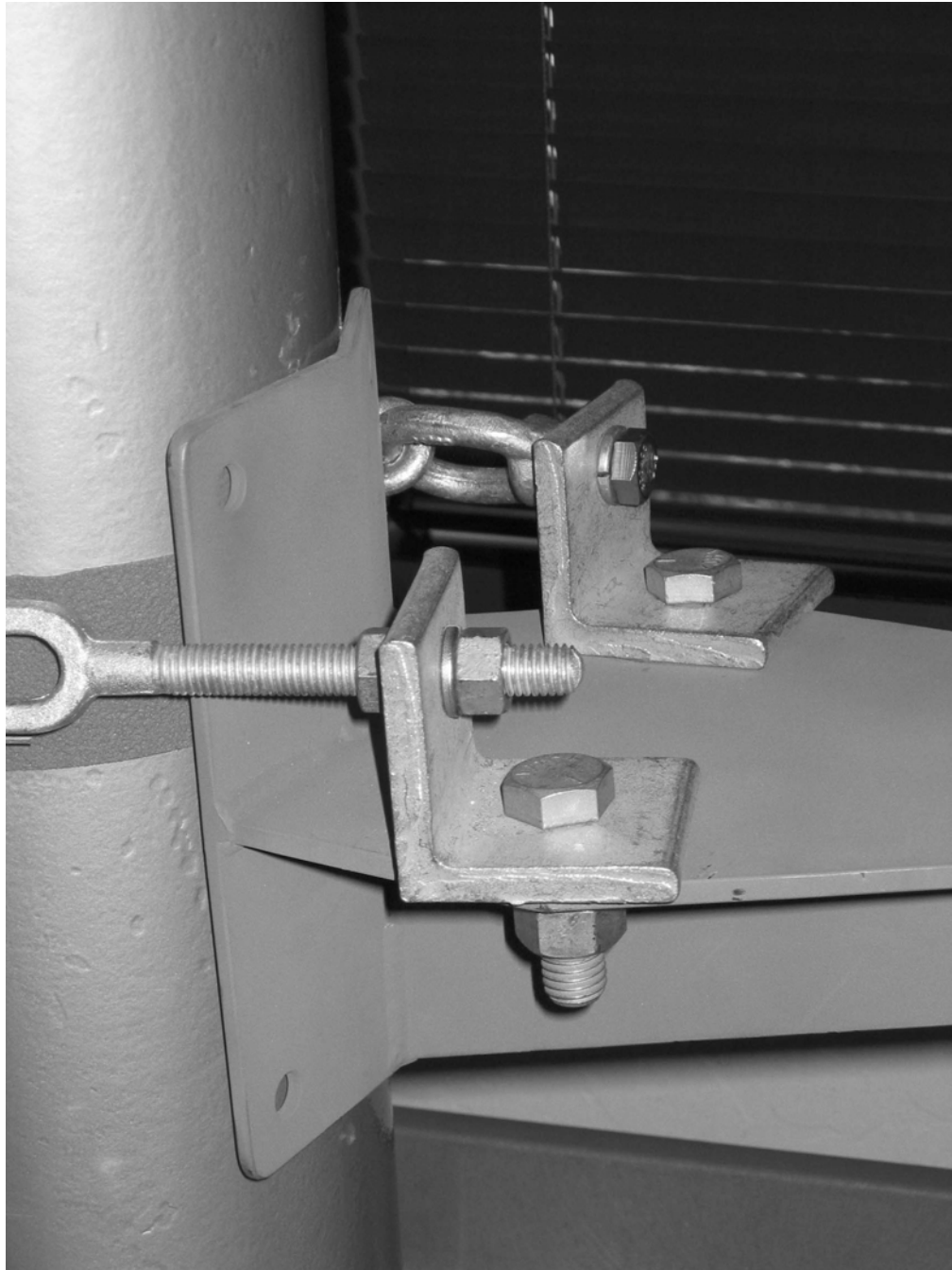

Figure 4-8: Pole-mount kit detail.



Figure 3-9: Pole Mount Kit and pipe mounted AP detail.