

Hellenbrand



H-125 SERIES™

WATER CONDITIONING SYSTEM
WITH HP ELECTRONICS

Owner's Manual

©2008

Manufactured by:
HELLENBRAND, INC.

404 Moravian Valley Road • Waunakee, Wisconsin 53597
Phone: 608-849-3050 • Fax 608-849-7398
Web: www.hellenbrand.com • Email: info@hellenbrand.com

This owner's manual is designed to assist owners and installers with the operation, maintenance and installation of your new water softener. It is our sincere hope that this manual is clear, concise and helpful to both owner and installer. We have included detailed instructions on general operating conditions, pre-installation and installation instructions, start-up, and timer and meter programming. We have included a troubleshooting guide, service instructions and parts diagrams to assist you.

Owners will appreciate the simplified, illustrated format for operation, programming and troubleshooting. **In the event that you need professional assistance for servicing your water softener, please contact the dealer who installed this system.**

TABLE OF CONTENTS

Job Specification Sheet.....	3
Soft Water Basics	4
Operating Conditions.....	4
Pre-Installation Check List.....	5
Installation Instructions.....	6
Programming.....	7-17
Water Softener Disinfection.....	18
Water Softener Draining Procedure	18
Trouble Shooting	19-21
Conditioner and Salt Assemblies.....	22
Parts Diagrams.....	23-28
Wrench	29
Flow Diagrams.....	30-32
Specifications	33
Programing Options.....	34
Operation Specifications.....	34
Service Instructions	35-37
Pressure Drop Charts.....	38-39
Warranty	40

Dealer Name _____ Phone _____

Address _____

JOB SPECIFICATION SHEET

MODEL NO. _____

*WATER TEST AT TIME OF INSTALLATION

_____ Hardness CaCo₃ (gpg) _____ Other _____
_____ Iron (ppm) _____ Other _____
_____ pH _____ Other _____
_____ Reclamation mode enabled
_____ No Hard By-pass enabled
_____ Alternator system enabled

OPTIONAL RELAY SETTINGS

_____ Off

Relay 1

On Time

_____ Relay 1 Set Point
_____ Start Time, Minutes into Regeneration
_____ Relay 1 Duration
_____ Run Time

On Gallons

_____ Relay 1 Set Point
Pulse per _____ Gallons
_____ Relay 1 Duration
_____ Minutes Relay Closed
_____ Relay 1 Set Point

On Regen Gallons

_____ Relay 1 Set Point
Pulse per _____ Gallons
_____ Relay 1 Duration
_____ Minutes Relay Closed
_____ Relay 1 Set Point

Relay 2

On Time

_____ Relay 2 Set Point
_____ Start Time, Minutes into Regeneration
_____ Relay 2 Duration
_____ Run Time

On Gallons

_____ Relay 2 Set Point
Pulse per _____ Gallons
_____ Relay 2 Duration
_____ Minutes Relay Closed
_____ Relay 2 Set Point

On Regen Gallons

_____ Relay 2 Set Point
Pulse per _____ Gallons
_____ Relay2 Duration
_____ Minutes Relay Closed
_____ Relay 2 Set Point

*SIZING INFORMATION

All Water is Softened Except:

_____ Rear Hose Bib _____ Front Hose Bib _____ Kitchen Cold _____ Toilets _____ All Cold
_____ Other _____

The average family uses 75 gallons per person daily for all water uses in the home, about 50 gallons per person daily if soft water is not supplied to the toilets, and about 30 gallons per person daily if only hot water is softened.

_____ Daily Water Usage (Gallons/Person)
x _____ Family Size (Number of people in family)
= _____ Total Gallons Per Day
x _____ Grains Per Gallon of Hardness
(Note: Add 3 grains per gallon of hardness for each ppm iron for total compensated hardness)
= _____ Total Grains Per Day

*INSTALLATION DATE _____

*SERIAL NUMBER _____

NOTES _____

SOFT WATER BASICS

Hardness

Hardness in water is the amount of calcium and magnesium present. A water softener removes the majority of calcium and magnesium to produce softened water.

Hardness is measured in units of grains per gallon. When your water is tested the hardness is calculated and expressed as grains per gallon (gpg). This calculation, as well as the number of people in your household will help determine what type and size of water softener will most efficiently soften your water.

Your water softener contains an ion exchange media (sometimes called resin) which removes the hardness from water as it flows through the softener tank. Eventually so much hardness collects on the exchange media that the softener can no longer soften water. At this point it is considered "exhausted". Regeneration is now necessary.

Regeneration

When ion exchange resin is saturated with calcium and magnesium (hard water ions) it must be recharged. This is accomplished by rinsing the resin with a salt solution. The salt solution removes the hardness and replaces it with sodium. The exchange media is then ready to remove hardness from water. The hardness minerals and excess brine solution are rinsed down the drain.

During the regeneration cycle the softener is also backwashed. This reversing of the normal flow of water serves to remove sediment which may have accumulated during the softening process due to the filtering action of the exchange media. Backwashing also loosens and fluffs up the bed of exchange media to insure that during regeneration the brine solution will come into contact with all the ion exchange media.

Maintenance of Your Softener

Salt: Salt to a softener is what gasoline is to a car. Not only must a softener have salt, but it should be the proper type to insure efficient recharging of the unit. Ask your dealer what type of salt may best suit your needs. Always have an adequate supply of salt on hand. Check the salt level of your brine tank every couple of weeks initially to determine how much salt you use - this will depend on how much water you use. As a rule of thumb, with 20 gpg hard water, about a 1/2 lb. of salt per person per day is used. In other words, a family of four uses 60 lbs. of salt a month. If your household does not use much water, do not fill your brine tank over 1/2 full, salt bridging may occur in the brine tank. This may result in hard water due to ineffective regeneration. Fill the tank approximately three-fourths full, with a minimum of 12" of salt. DO NOT USE block salt when the H-125 control is programmed with a brine tank prefill. Block salt does not dissolve quick enough to provide a good regeneration.

Cleaning Brine Tank: Salt tank may require periodic cleaning. Inspect the brine tank at least once a year for buildup of insoluble materials. It is recommended to periodically clean the brine tank no matter what kind of salt you are using. See page 15, Miscellaneous #2 for details on cleaning.

REMEMBER: Salt is the fuel to run your water softener. Buy the **best clean salt available.**

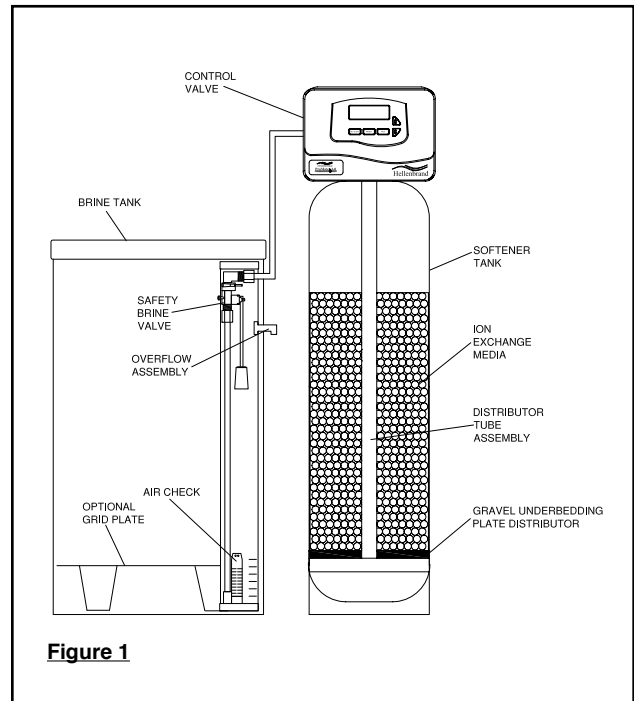

Figure 1

OPERATING CONDITIONS

Your water conditioner has been designed to adequately handle up to 100 grains per gallon of hardness that might be encountered as well as up to 2 ppm of Ferrous Bicarbonate Iron. This is iron that is dissolved in an oxygen-free water supply. It is not visible to the eye in a freshly drawn sample because the water appears clear. But upon standing in contact with air, the ferrous iron will become oxidized to the ferric state and start to precipitate as a reddish brown floc. It can then be seen and if allowed to remain in the supply will cause discolored water. In order for your conditioner to remove the iron, air (oxygen) must

be kept from coming in contact with water until after it has been passed through the water conditioner. In some cases, additional equipment may be required to treat water supplies having special characteristics, such as: ferric hydroxide iron, iron bacteria, low pH, taste and odors, etc. If any question should exist, contact your dealer.

This water softener is not intended to be used for treating water that is microbiologically unsafe or of unknown quality without adequate disinfection before or after treatment.

PRE-INSTALLATION CHECK LIST

(All electrical & plumbing should be done in accordance to all local codes)

Water Pressure: A minimum of 25 pounds of water pressure (psi) is required for regeneration. Maximum 125 psi.

Water Quality: On rural water supplies there is often a problem with sand or sediment in the water. (This problem occasionally occurs in public water supplies.) If the water is not filtered before being softened, the sand and sediment will plug up the water softener restricting the flow through the resin bed. This problem often requires rebedding of the mineral tank. **Note:** Well and/or pump problems affecting the operation of the softener are repairs that are not covered under warranty. To prevent these unnecessary, and expensive repairs not covered under warranty, we recommend the installation of an in-line filter system ahead of the softener.

Electrical: A continuous 110 volt, 60 cycle current supply is required. Make certain the current supply is uninterrupted and cannot be turned off with another switch. All electrical connections must be connected per local codes. **Surge protection is recommended with all electric controls.**

Existing Plumbing: Condition of existing plumbing must be free from lime and iron build-up. Piping that is built-up heavily with lime and/or iron must be replaced. If piping is blocked with iron, additional equipment must be installed ahead of the water conditioner to correct the problem.

Drain Line: The conditioner should be located close to a drain. Avoid overhead drain lines if possible to prevent back pressure on the brine injector. Overhead drains are not to exceed 8 feet above the floor and no more than 20 feet in length. The pipe size for the drain line should be a minimum of 3/4". Backwash flow rates in excess of 7 gpm or length in excess of 20' require 1" drain line.

Bypass Valves: Always provide for the installation of a bypass valve.

Softening: It is recommended that the conditioner be installed to soften both the hot and cold water supply. A separate hard water faucet may be plumbed for drinking purposes if you desire. Outside faucets should be left on hard water.

Caution: Water temperature is not to exceed 110°F; the conditioner cannot be subject to freezing conditions, or to a vacuum due to loss of pressure (such as a water main break).

BYPASS VALVE OPERATION

NORMAL OPERATION

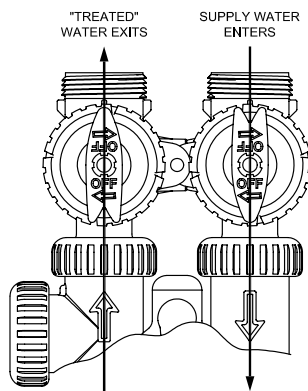

Figure 2

BYPASS OPERATION

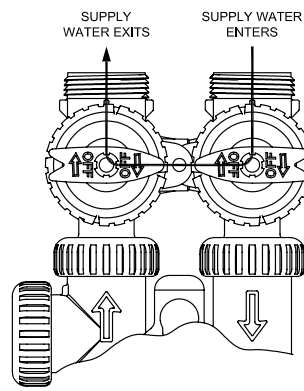

Figure 3

DIAGNOSTIC MODE

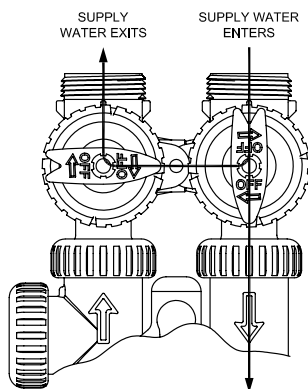

Figure 4

SHUT OFF MODE

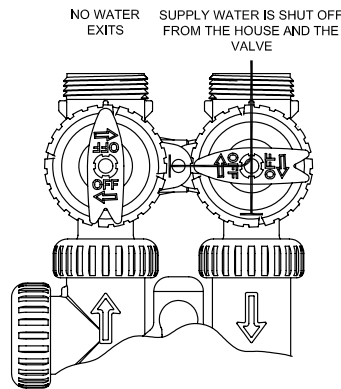

Figure 5

INSTALLATION INSTRUCTIONS

(All electrical & plumbing should be done in accordance to all local codes)

- Do not use vaseline, oils, other hydrocarbon lubricants or spray silicone anywhere. A silicon lubricant may be used on black o-rings but is not necessary. **Avoid any type of lubricants, including silicone, on red or clear lip seals.**
 - Do not use pipe dope or other sealants on threads. Only teflon tape may be used on threads. Teflon tape is not necessary on the nut connection or caps because of o-ring seals.
 - The pipe size for the drain line should be a minimum of 3/4". Backwash flow rates in excess of 7 gpm or length in excess of 20' require 1" drain line.
1. Place the conditioner where you want to install it, making sure it is on a clean, level and firm base.
 2. Do all necessary plumbing (inlet to inlet, outlet to outlet and drain line to drain). The control valve, fittings and/or bypass are designed to accommodate minor plumbing misalignments but are not designed to support the weight of a system or the plumbing.
 3. When assembling the installation fitting package (inlet and outlet), connect the fitting to the plumbing system first and then attach the nut, split ring and o-ring. Heat from soldering or solvent cements may damage the nut, split ring or o-ring. Solder joints should be cool and solvent cements should be set before installing the nut, split ring and o-ring. Avoid getting primer and solvent cement on any part of the o-rings, split rings, bypass valve or control valve.
 4. **A jumper ground wire should be installed between the inlet and outlet pipe whenever the metallic continuity of a water distribution piping system is interrupted. Install jumper ground wire on metal pipes.**
 5. The drain connection may be made using either 5/8" polytube (See figure 6a, page 6) or a 3/4" female adapter. If soldering, joints near the drain must be done prior to connecting the

drain line flow control fitting. Leave at least 6" between the drain line control fitting and solder joints when soldering pipes that are connected on the drain line control fitting. Failure to do this could cause interior damage to the drain line flow control fitting.

6. The brine refill flow control assembly is installed in an easy to access refill elbow located on top of the control valve. The refill flow control assembly is attached to the control valve with a locking clip. The locking clip allows the elbow to rotate 270 degrees so the outlet can be orientated towards the saltkeeper.
7. Connect the brine line found in the brine tank to the brine connection on the control valve. The control valve has a standard refill elbow which a 3/8" flexible tube can be connected, see figure 6a, page 6. (An optional elbow can be ordered which accommodates a 1/2" flexible tube for a high regenerant draw rate situation). Both elbows use the same refill flow control and retainer. Do not connect the other end of the brine line to the safety brine valve in the brine tank at this time. Make sure the floor is clean beneath the salt tank and that it is level and smooth.
8. A 1/2" (inside diameter) gravity drain line should be connected to the overflow elbow on the side of the brine tank and run to a drain below the level of the elbow. This overflow drainage system provides protection from water damage in the event of a brine shut-off malfunction. Tubing is not provided to do this.

In all cases where an overflow could result in water damage for various reasons, this overflow protection must be used. Do not connect the tubing to the drain line on the control valve discharge line and do not run this line above the overflow elbow height at any point. Provide air gap.

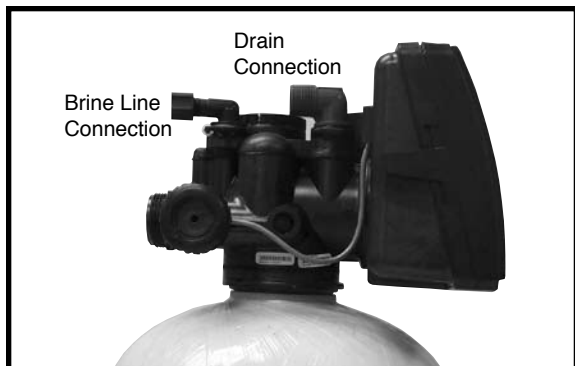
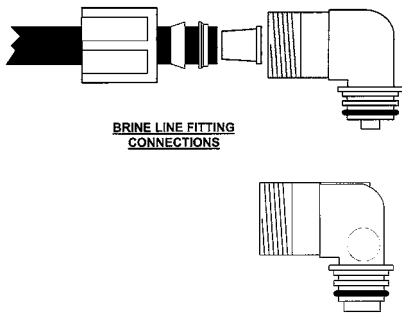

Figure 6a

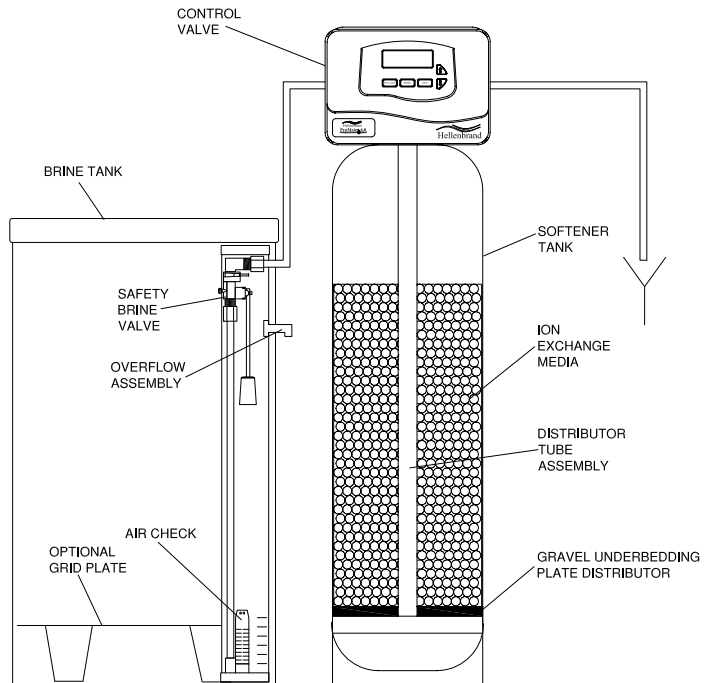

Figure 6b

PROGRAMMING

General Information

The H125 control valve is the “brain” of your water softener. It consists of the valve body and powerhead with solid state microprocessor.

The display panel (see Figure 7) consists of the LCD display and five push buttons which are used in displaying and programming the water softener settings.

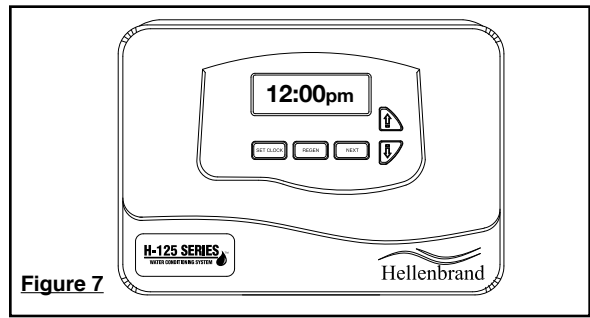

Initial Start Up

The initial start up will probably be done by the technician installing the softener system. If not, the following instructions will step you through the process.

1. Complete all plumbing connections: inlet, outlet, drain line and brine line. Do not add salt at this time.
2. Place the bypass valve in the bypass position. (See figure 3 page 5) Turn on the main water supply. Open a cold soft water faucet to flush the piping of any air and/or foreign material. Run until the water is clear.
3. Manually add 6 inches of water to the brine tank.
4. Now plug the transformer into a 110-volt receptacle. (Be certain the outlet is uninterrupted.) Within 5 seconds the control will automatically align itself into the softening mode and display will automatically alternate between time of day, gal/min and gallons remaining. (Figure 8, page 7).
5. Set the time of day by pushing clock button (figure 9, page 8) and using ▲ and ▼ buttons.
6. Push REGEN button and hold it down for 3 seconds. The system will advance to the “First” position. (Note: Depending on how the system is programmed it could read backwash, rinse, brine or fill). Keep pushing REGEN button until “Rinse” shows in the lower right hand corner of display. Slowly place the by-pass into the “diagnostic mode” (see fig 4, page 5). Run water to the drain until it runs clear. Return the by-pass valve to the by-pass position (fig 3, page 5). Push REGEN button until “unit is back to softening mode.”
7. Once again, push REGEN button and hold down for 3 seconds. Keep pushing REGEN button until “Back-

wash” appears. Slowly place the by-pass valve into the “Diagnostic Mode” 1/2 way. Allow water to slowly fill the mineral tank. When a solid stream of water starts coming out of the drain line, open the by-pass inlet valve all the way and allow to run out the drain until water clears. Then slowly place the by-pass into the “normal operation” mode by opening the outlet side of by-pass valve, figure 2, page 5.

8. Press the REGEN button until LED display says “REGENERANT DRAW-DN”. Loosen the brine line from the control valve. Place finger over the end of brine connection on valve to check for suction. If no suction, see trouble-shooting guide. (See #11, Page 20) If proper suction, attach brine tube to control valve, and allow it to draw water down to the bottom of the air check, (figure 6b, page 6).
9. Press REGEN button again until LED once again displays “BACKWASH”. Keep in backwash until water once again runs clear at the drain.
10. Press REGEN button again until “RINSE” is displayed. Allow rinse cycle to run its full course. While the rinse cycle is finishing, this would be a good time to load your brine tank with salt. **If utilizing brine recovery, add full volume of water to brine tank for the 1st REGENERATION.**
11. Once the rinse cycle has finished, the softener control will return to the softening cycle. The LED screen will scroll between “TIME/GPM/GALLONS REMAINING”.
12. Next set your softeners water hardness, days override and regeneration time settings (see figure 10a, page 8).

Your programming is now complete.

General Operation

When the system is operating, one of three displays may be shown. Pressing NEXT will alternate between the displays. One of the displays is the current time of day. The second display is one of the following: days to a regen or gallons remaining. Days To A Regen is the number of days left before the system goes through a regeneration cycle. Capacity remaining is the number of gallons that will be treated before the system goes through a regeneration cycle. The third display is current flow in gal/min. The user can scroll between the displays as desired by pushing NEXT or display will scroll automatically.

When water is being treated (i.e. water is flowing through the system) the word "GPM" flashes on left side of display when other than flow rate is displayed.

USER DISPLAYS/SETTINGS

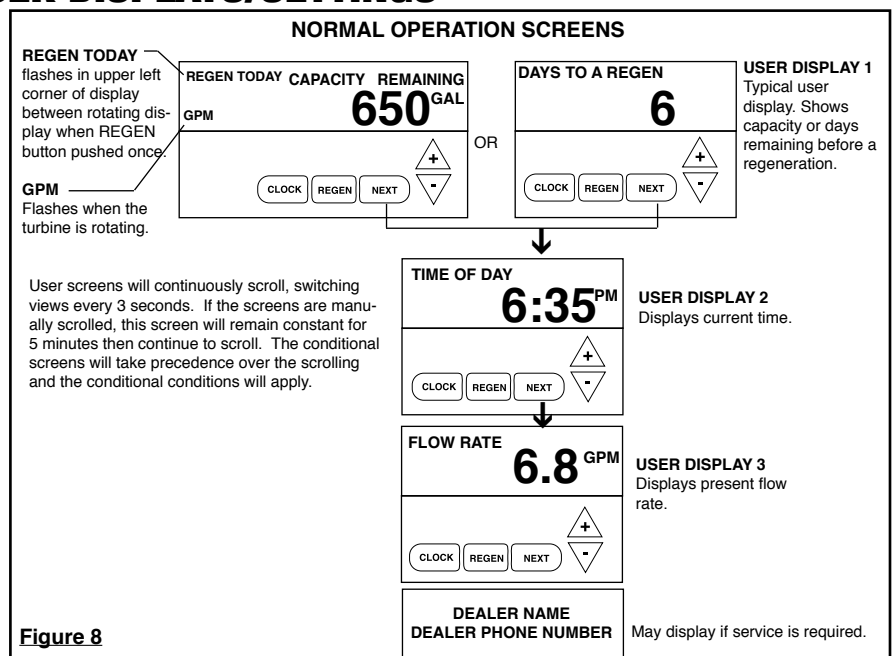

Figure 8

SET TIME OF DAY

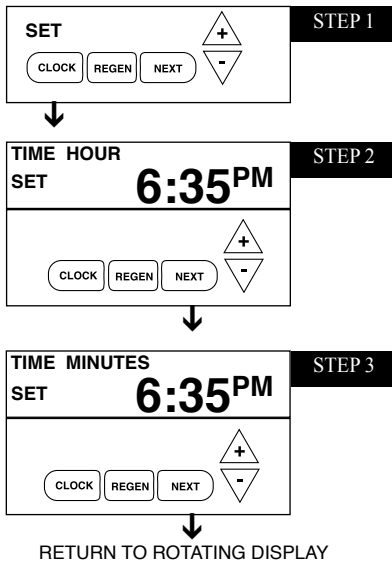

Figure 9

▲ = ▲ Up Arrow ▼ = ▼ Down Arrow

Step 1 - Press SET CLOCK.

Step 2 - Current Time (**hour**): Set the hour of the day using ▲ or ▼ buttons. AM/PM toggles after 12. Press NEXT to go to step 3.

Step 3 - Current Time (**minutes**): Set the minutes of day using ▲ or ▼ buttons. Press NEXT to exit Set Clock. Press REGEN to return to previous step.

Power Loss - Lithium battery on circuit board provides up to 2 years of time clock backup during power outages. If the power is out when battery is depleted, only time of day needs to be reset, all other values are stored in non-volatile memory. When time of day is flashing, replace lithium coin type 2032 battery.

Battery back-up feature will be activated after 24 hours of power.

Do not forget to reset for daylight savings time.

INSTALLER DISPLAYS/SETTINGS

▲ = ▲ Up Arrow ▼ = ▼ Down Arrow

Step 1 - Press NEXT and ▲ simultaneously for 3 seconds.

Step 2 - Hardness: Set the amount of total compensated hardness in grains (hardness as calcium carbonate) per gallon using ▲ or ▼ buttons. **The factory setting is 20** with value ranges from 1 to 150 in 1 grain increments. Note: The grains per gallon should be increased if soluble iron needs to be reduced. Add 3 grains of hardness for each ppm of iron present. If this display shows nA -, then system is set-up in "filter" mode or "AUTO" is not selected in softener system setup. (See page 34). Press NEXT to go to Step 3. Press REGEN to exit Installer Displays/Settings.

Step 3 - Day Override: This sets the number of days between regenerations. If value set to "oFF" regeneration initiation is based solely on gallons used. If value is set as a number (allowable range from 1 to 28) a regeneration initiation will be called for on that day even if sufficient number of gallons were not used to call for a regeneration. Set Day Override using ▲ or ▼ buttons: **Factory setting is 14 days.**

- number of days between regeneration (1 to 28); or
- "oFF"

See figure 12a & b, page 11-12, for more detail on softener setup. Press NEXT to go to step 4. Press REGEN to return to previous step.

Step 4 - Regeneration Time (hour): Set the hour of day for regeneration using ▲ or ▼ buttons. AM/PM toggles after 12. The factory setting time is 2:00 a.m. This display will show "REGEN" "IMMEDIATE ON ZERO GAL" if "Immediate" is selected on Step 12 of softener set-up. See page 34. Press NEXT to go to step 5. Press REGEN to return to previous step.

Step 5 - Regeneration Time (minutes): Set the minutes of day for regeneration using ▲ or ▼ buttons. This display will not be shown if system is set for immediate regeneration. Press NEXT to exit Installer Displays/Settings. Press REGEN to return to previous step.

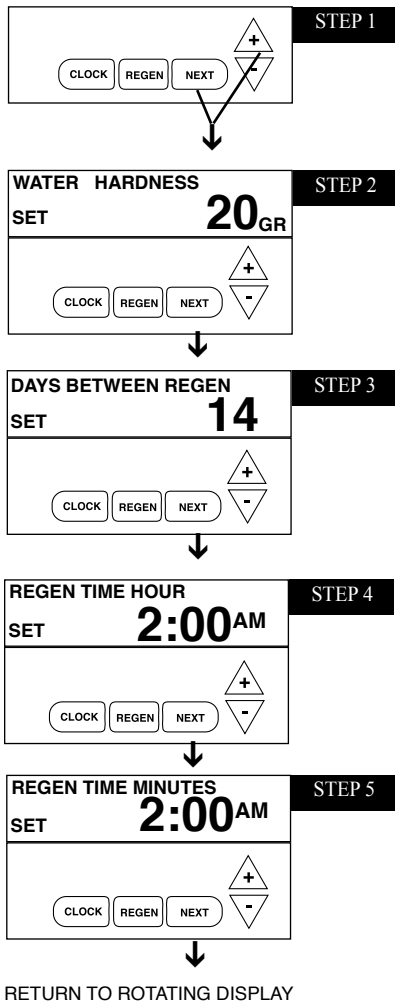
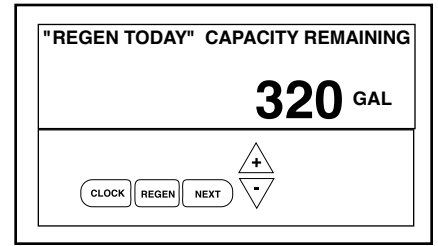

Figure 10a

Manual Regeneration

Sometimes there is a need to regenerate the system, sooner than when the system calls for it, usually referred to as manual regeneration. There may be a period of heavy water usage because of guests or a heavy laundry day.

To initiate a manual regeneration at the preset delayed regeneration time, press and release "REGEN". The words "REGEN TODAY" will flash in left corner of display as it scrolls through displays to indicate that the system will regenerate at the preset delayed regeneration time. If you pressed the "REGEN" button in error, pressing the button again will cancel the request.



To initiate a manual regeneration immediately, press and hold the "REGEN" button for five seconds. The system will begin to regenerate immediately. The request cannot be cancelled. You must cycle all the way through the cycles to make it stop. PLEASE NOTE: This will reset the meter.

Note: If the salt tank does not contain salt, fill with salt and wait at least two hours before regenerating. If two regenerations are desired within 24 hour period, press /release REGEN button. REGEN TODAY will flash on screen. Press and hold REGEN button until valve initiates regeneration.

Regeneration Mode

Typically a system is set to regenerate at a time of low water usage. An example of a time with low water usage is when the household is asleep. If there is a demand for water when the system is regenerating, untreated water will be supplied.

When the system begins to regenerate, the display will change to include information about the step of the regeneration process and the time remaining for that step to be completed (see figure 11). The system runs through the steps automatically and will reset itself to provide treated water when the regeneration has been completed.

Regeneration Step
(shows time remaining in regen step
is 8 minutes, 22 seconds)

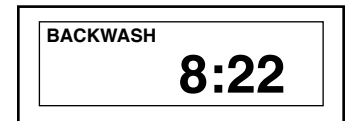

Figure 11

CYCLE TIME ADJUSTMENTS

Normally it is not recommended to adjust the lengths of the cycle times. However, certain water conditions may dictate adjustments. This should only be done from the recommendation of a water conditioning professional. The following chart shows the upper and lower limits of each cycle.

Cycle Options	Units	Lower/Upper Limit	Factory Setting
Fill	Lbs.	0.1 to 200	See Page 33
Softening (Service)	Minutes	1 to 480	120
Backwash	Minutes	1 to 120	8
Regenerant Draw DN	Minutes	1 to 180	60
Backwash	Minutes	1 to 120	8
Rinse-Fast	Minutes	1 to 120	4

SOFTENER SETUP

▲ = ▲ Up Arrow ▼ = ▼ Down Arrow

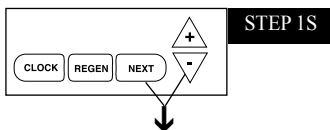

STEP 1S – Press NEXT and ▼ simultaneously for 3 seconds. If screen in Step 2S does not appear in 5 seconds the lock on the valve is activated.

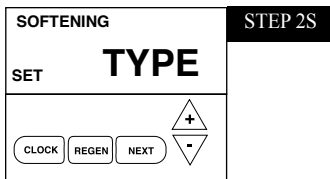

STEP 2S – Select between softening or filtering. A flashing "SOFTENING" or "FILTERING" will appear. Choose SOFTENING using ▼ or ▲ button. **Factory setting is Softening.** Press NEXT to go to Step 3S. Press REGEN to exit Softener System Setup.

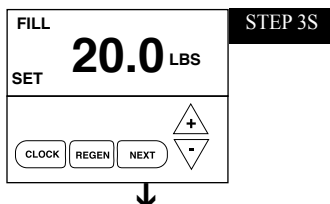

STEP 3S – Select the time for the first cycle (which in this example is FILL, setting is changed by lbs. of salt entered) using the ▼ or ▲ button. **Factory setting is Medium Salting,** See page 33. Press NEXT to go to Step 4S. Press REGEN to return to previous step.

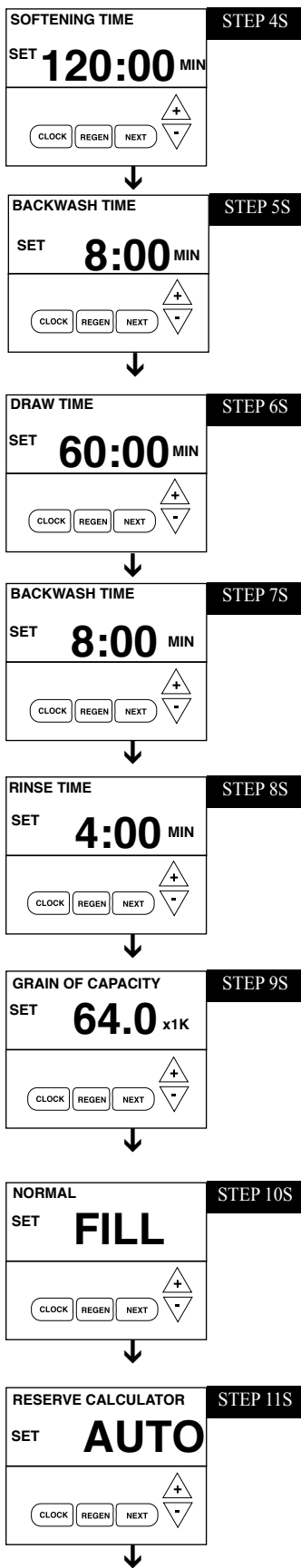

Figure 12a

STEP 4 S – Select the time for the second cycle (which in this example is SOFTENING) using ▼ or ▲ button. Press NEXT to go to Step 5S. Press REGEN to return to the previous step.

STEP 5 S – Select the time for the third cycle (which in this example is BACKWASH) using the ▼ or ▲ button. Press NEXT to go to Step 6S. Press REGEN to return to the previous step.

STEP 6 S – Select the time for the fourth cycle (which in this example is dn BRINE) using the ▼ or ▲ button. Press NEXT to go to Step 7S. Press REGEN to return to the previous step.

STEP 7 S – Select the time for the fifth cycle (which in this example is BACKWASH) using the ▼ or ▲ button. Press NEXT to go to Step 8S. Press REGEN to return to the previous step.

STEP 8 S – Select the time for the sixth cycle (which in this example is RINSE) using the ▼ or ▲ button. Press NEXT to go to Step 9S. Press REGEN to return to the previous step.

STEP 9 S - Set Grain Capacity using the ▼ or ▲ button. The ion exchange capacity is in grains of hardness as calcium carbonate for the system based on the pounds of salt that will be used. The allowable grains capacity range varies from 5,000 to 500,000 grains. The increment increase is 500 for the range from 5000 to 50,000; 1000 for the range of 50,000 to 200,000; and 2000 for the range of 200,000 to 500,000. Grains capacity is affected by the fill time. The grains capacity for the selected lbs. salting should be confirmed by testing. The capacity and hardness levels entered are used to automatically calculate reserve capacity when gallon capacity is set to AUTO. **Factory setting is the capacity of the softener at medium salting.** See Page 33. Press NEXT to go to Step 10S. Press REGEN to return to previous step.

STEP 10 S – Select between proportional or normal brining. Use ▼ or ▲ buttons to select. **Proportional brining is only available if configured as prefill/upflow softener or screen will not appear.** Proportional brining will divide the actual gallons used by calculated volumetric capacity then multiply fill volume by this percentage. This option requires a functioning meter. **Factory Setting = Normal brining.** Press NEXT to go to Step 11S. Press REGEN to return to previous step.

STEP 11 S – Set Gallons Capacity using ▼ or ▲ button. If value is set to:

- “AUTO” gallon capacity will be automatically calculated and reserve capacity will be automatically estimated;
- “oFF” regeneration will be based solely on the day override set (see Installer Display/Settings Step 3, page 8 / proportional brining will not fuction if OFF selected); or
- as a number of gallons (allowable range 20 to 250,000) regeneration will be based on the value specified.

Increment increase is 20 for the range 20 to 2000, 100 for the range of 2000 to 10,000 and 500 for the range of 10,000 to 50,000 and 2000 for range of 50,000 to 250,000.

If “oFF” or a number is used, hardness cannot be set in Installer Displays/Settings Step 2, page 8. See page 34 for more detail. **Factory Setting is AUTO.** Press NEXT to go to Step 12 S. Press REGEN to return to previous step.

DELAY + IMMEDIATE **STEP 12S**

SET **REGEN**

CLOCK REGEN NEXT

+/-

STEP 12 S – Set Regeneration Time Options using the ▼ or ▲ button. If value is set to:

- “DELAY” means regeneration will occur at the preset time; (page 8, step 4)
- “IMMEDIATE” means regeneration will occur immediately when the gallons capacity reaches 0 (zero); or
- “DELAY + IMMEDIATE” means regeneration will occur at one of the following:
 - the preset time when the gallons capacity falls below the reserve or the specified number of days between regenerations is reached, whichever comes first; or
 - immediately after 10 minutes of no water usage when the gallon capacity reaches 0 (zero).

See page 34 for more options. **Factory Setting is DELAY + IMMEDIATE.** Press NEXT to go to Step 13S. Press REGEN to return to previous step.

RELAY 1 TRIGGER **STEP 13S**

SET **TIME**

CLOCK REGEN NEXT

+/-

STEP 13 S – Set Relay to activate by Time or Gallons, REGEN GALLONS or OFF by using ▼ or ▲ buttons. A relay can be used to operate a chemical feed pump or solenoid. The choices are:

- **Relay Triggered on Time** - Relay activates after set number of minutes after start of regeneration. Start of regeneration is defined by first backwash cycle, dn brine or up brine, whichever is first. Relay deactivates after set time.
- **Relay Triggered on Gallons** - Relay activates every set number of gallons while in service and deactivates after set time.
- **Regen Gallons** - Relay activates after set number of gallons in service and if any water is used during regeneration and de-activates after set time or when meter stops registering flow, whichever comes first.
- **Off** - If off is selected, Steps 14S or 15S will not be shown. **Factory setting = OFF.** Press NEXT to go to step 14S or 15S for relay settings, or 20S if OFF selected.

RELAY 1 SET POINT **STEP 14S**

SET **10 MIN**

CLOCK REGEN NEXT

+/-

STEP 14 S – If off was selected in previous step, this screen does not appear.

If Time chosen to Activate Relay, use up and down arrows to set # of minutes AFTER START OF REGEN to activate relay. Press NEXT.

Start of regeneration is defined as first Backwash or Regenerant Draw.

RELAY 1 DURATION **STEP 15S**

SET **3:00 MIN**

CLOCK REGEN NEXT

+/-

STEP 15 S – Use Up and Down arrows to set duration of relay activation in minutes. Time Range = 1 second - 500 minutes. Press NEXT to go to Step 20S. Press REGEN to return to previous step.

RELAY 1 TRIGGER

SET **GALLONS**

CLOCK REGEN NEXT

+/-

Gallons Chosen to Activate Relay, This screen indicated gallons chosen to activate relay. If Off or Time was selected in previous steps, this screen does not appear. Press NEXT to select number of gallons per relay activation.

RELAY 1 SETPOINT **STEP 16S**

SET **1 GAL**

CLOCK REGEN NEXT

+/-

STEP 16 S – use up and down arrows to set # of gallons per relay activation. Range = 1-100 gallons. Press NEXT to select duration of relay activation.

RELAY 1 DURATION **STEP 17S**

SET **0:01 MIN**

CLOCK REGEN NEXT

+/-

STEP 17 S – Use up and down arrows to set duration of relay activation in minutes. Range = 1 second - 500 minutes. Press NEXT to go to Step 20S. Press REGEN to return to previous step.

Figure 12b

RELAY 1 SETPOINT
SET **REGEN** GAL

CLOCK REGEN NEXT

▲
▼

If **REGEN gallons chosen to activate relay**. Relay activates after set number of gallons have been used in service and if any water is used during regeneration and then deactivates after set period of time or after flow stops, whichever comes first. Press NEXT to select number of gallons per relay activation.

RELAY 1 SETPOINT **STEP 18S**
SET **1** GAL

CLOCK REGEN NEXT

▲
▼

STEP 18 S – Use up and down arrows to set number of gallons per relay activation. Range 1-100 gallons. Press NEXT to select duration of relay activation.

RELAY 1 DURATION **STEP 19S**
SET **0:01** MIN

CLOCK REGEN NEXT

▲
▼

STEP 19 S – Use up and down arrows to set duration of relay activation in minutes. Range: 1 second - 500 minutes. Press NEXT to go to Relay 2 Trigger.

RELAY 2 TRIGGER
SET **TIME**

CLOCK REGEN NEXT

▲
▼

Relay 2 programming includes identical options as Relay 1.

RETURN TO ROTATING DISPLAY

SERVICE REMINDER

SERVICE ALARM **STEP 20S**
SET **BOTH**

CLOCK REGEN NEXT

▲
▼

STEP 20S – Set scheduled service alarm using ▲ or ▼ buttons. Available options are OFF, TIME, ON GAL or BOTH. Selecting OFF disables this feature. If OFF is selected press NEXT to exit System Setup. If TIME, ON GAL or BOTH is selected press NEXT to select the TIME and/or ON GAL values. See Steps 21S and/or 22S. Press REGEN to return to the previous step.

SCHEDULED SERVICE **STEP 21S**
SET **0.25** YR

CLOCK REGEN NEXT

▲
▼

STEP 21S – Service alarm for TIME ranges from 0.25 to 9.75 years. Use ▲ or ▼ buttons to select value. Press NEXT to either exit System Setup or if BOTH was selected go to Step 22S. Press REGEN to return to the previous step.

SCHEDULED SERVICE **STEP 22S**
SET **80000** GAL

CLOCK REGEN NEXT

▲
▼

STEP 22S – Service alarm for ON GAL ranges from 100 to 9,999,900 gallons. Use ▲ or ▼ buttons to select value. Press NEXT to exit System Setup. Press REGEN to return to the previous step.

RETURN TO ROTATING DISPLAY

DIAGNOSTICS

▲ = ▲ Up Arrow ▼ = ▼ Down Arrow

Reset Diagnostic Values: Hold  ▼ NEXT/DOWN buttons for 3 seconds, then hold ▲ UP/DOWN buttons for 3 seconds.

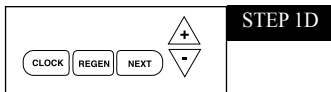

STEP 1D

STEP 1D – Press ▼ or ▲ simultaneously for three seconds. If screen in step 2D does not appear in 5 seconds the lock on the valve is activated.

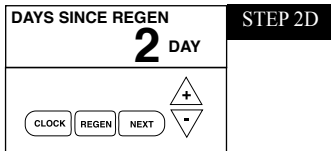

STEP 2D

STEP 2D – Days, since last regeneration: This display shows the days since the last regeneration occurred. Press the NEXT button to go to Step 3D. Press REGEN to exit Diagnostics.

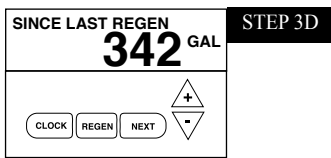

STEP 3D

STEP 3D – Volume, since last regeneration: This display shows gallons of water that has been treated since the last regeneration. This display will equal zero if a water meter is not installed. Press the NEXT button to go to Step 4D. Press REGEN to return to previous step.

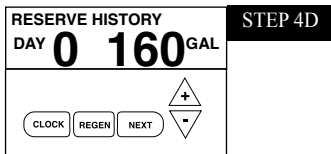

STEP 4D

STEP 4D – Volume of reserve capacity used for last 7 days: If the unit is set up as a softener, a meter is installed and Set Volume Capacity is set to "Auto", this display shows 0 day (for today) and the reserve capacity. Pressing the ▲ button will show day 1 (which would be yesterday) and displays the reserve capacity. Pressing the ▲ button again will show day 2 (the day before yesterday) and the reserve capacity. Keep pressing the ▲ button to show the capacity for days 3, 4, 5 and 6. The ▼ button can be pressed to move backwards in the day series. Press NEXT button at any time to go to Step 5D. Press REGEN to return to previous step.

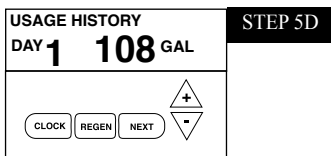

STEP 5D

STEP 5D – Volume of water used, 63-day usage history: This display shows day 0 (for today) and 1 (for yesterday) will show day 2 (which would be the day before yesterday) and flashes the volume of water treated on that day. Continue to press the ▲ button to show the volume of water treated for the last 63 days. If a regeneration occurred on the day the "letter R" will also be displayed. This display will show dashes if a water meter is not installed. Press the NEXT button at any time to go to Step 6D. Press REGEN to return to the previous step.

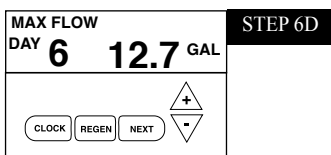

STEP 6D

STEP 6D – Flow rate, maximum of each of last seven days: The maximum flow rate in gallons per minute that occurred in each of the last seven days will be displayed. Press ▲ arrow to display maximum flow rate today = 0, yesterday = 1. This display will equal zero if a water meter is not installed. Press the NEXT button to exit Diagnostics. Press REGEN to return to the previous step.

To reset diagnostic data push "Next" and ▼ button until TYPE appears in window, then press "▲ & ▼" button simultaneously for 3 seconds.

RETURN TO NORMAL MODE

VALVE HISTORY

(Can not be reset)

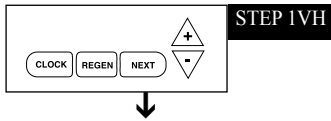

STEP 1VH – Press ▼ and ▲ simultaneously for three seconds and release, then press ▼ and ▲ simultaneously and release. If screen in step 2VH does not appear in 5 seconds the lock on the valve is activated.

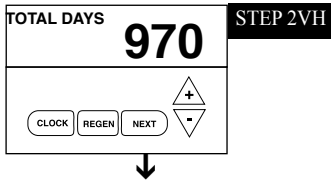

STEP 2VH – Days, total since start-up: This display shows the total days since startup. Press the NEXT button to go to Step 3VH. Press REGEN to return to previous step.

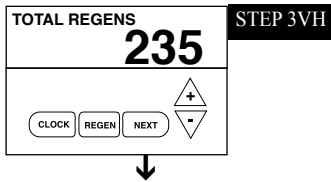

STEP 3VH – Regenerations, total number since start-up: This display shows the total number of regenerations that have occurred since startup. Press the NEXT button to go to Step 4VH. Press REGEN to return to previous step.

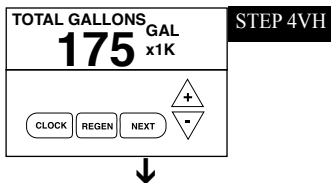

STEP 4 VH – Volume, total used since start-up: This display shows the total gallons treated since startup. This display will equal zero if a water meter is not installed. Press NEXT button to exit Valve History. Press REGEN to return to previous step.

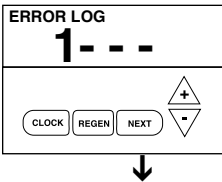

Use ▼ and ▲ arrows to display sequential error codes.

RETURN TO ROTATING DISPLAY

CYCLE SEQUENCE

Anytime cycle sequence is modified, softener set-up will revert to manufacturer setting and must be reprogrammed as desired.

Cycle Sequence instructions allows the operator to set the order of the cycle. The Softener System Setup allows the operator to set how long the cycles will last. The operator may choose up to 9 cycles in any order.

Cycle Options		
BACKWASH	REGENERANT DRAW-DN	FILL
RINSE	SOFTENING	END

END must be used as the last cycle option. The SERVICE cycle should only be used in brine prefill applications to allow salt to dissolve.

The following is an example of how to set a valve so that when regeneration is initiated, BACKWASH occurs first, REGENERANT DRAW DN occurs second, RINSE occurs third, and FILL occurs fourth.

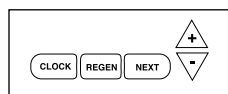

STEP 1 CS – Press NEXT and ▼ simultaneously for five seconds or until display changes and release. Then press NEXT and ▼ simultaneously again for 5 seconds and release. If screen in step 2CS does not appear in 5 seconds the lock on the valve is activated.

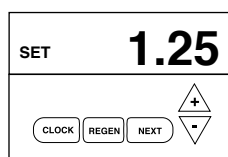

STEP 2 CS – Meter Size. Use the ▲ or ▼ to select from 1.0", 1.25", 1.50", 2.0" meter. H125 is a 1.25" meter. It is necessary to select meter size to coincide with control valve size used. Press NEXT to go to Step 3C.

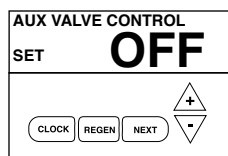

STEP 3CS – Use the ▲ or ▼ to select on of the following:

- OFF; or
- Brine Reclaim – Step 4CS; or
- Twin Alternating System – Step 6CS; or
- No Hard Water Bypass During Regeneration – Step 7CS.
- **Factory Setting is OFF**

Brine Reclaim: When Reclamation Mode is ENABLED, a portion of the unused brine is diverted after it has passed through the resin bed. Brine discharge contains unused salt that can be used for brine make-up for the next regeneration. A motorized alternator valve (MAV) must be connected to the two-pin connector labeled ALTERNATOR DRIVE located on the circuit board or error code 106 will result. The MAV diverts the brine discharge to brine tank. A-Port discharges to brine tank. B-Port discharges to drain. Start time and duration settings are for specified pressures, if variation occurs on site, elution study can be done to provide settings that optimize salt savings without sacrificing capacity. For detailed instructions, see Brine Recovery instructions (73-355-BR).

Programming needed for Brine Recovery:

1. Start Time
2. Duration
3. Lower Salt Setting

BRINE RECLAIM

Water Pressure	start time / duration / salt setting - 10 lbs./ft ³		
	H125-32-10	H125-48	H125-64
35 PSI	40:00/10:00/2.0	40:00/12:00/3.3	46:00/11:00/4.2
45 PSI	36:00/8:45/2.0	38:00/11:00/3.3	44:00/11:00/4.3
55 PSI	33:00/8:30/2.0	36:00/11:00/3.3	41:00/8:30/4.0
65 PSI	32:00/7:45/2.0	35:00/9:45/3.0	40:00/7:40/4.0

Water Pressure	start time / duration / salt setting - 10 lbs./ft ³			
	H125-96	H125-128	H125-160	H125-192
35 PSI	46:00/13:00/6.0	48:00/12:00/8.0	50:00/12:00/10.3	50:00/10:00/12.0
45 PSI	44:00/11:00/6.5	46:00/11:00/8.0	48:00/10:00/10.3	48:00/9:30/12.0
55 PSI	41:00/10:40/6.0	43:00/9:45/8.0	45:00/9:40/10.0	45:00/8:30/12.0
65 PSI	40:00/10:00/6.0	42:00/8:55/8.0	44:00/8:55/10.0	44:00/7:50/12.0

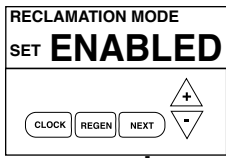

Only displays if reclamation of brine is enabled in Step 3CS. Selection requires that a connection to a MAV is made to the two-pin connector labeled DRIVE on PC Board.

Press NEXT to go to Step 4CS. Press REGEN to return to previous step.



STEP 4CS – Use the ▲ or ▼ buttons to select the number of minutes after the start of the draw cycle before the MAV will divert the brine waste water from the plumbing drain receptacle to the brine tank. Press NEXT to select duration of brine reclaim.

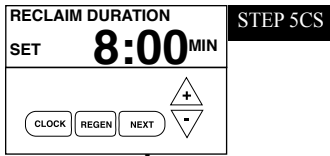

STEP 5CS – Only displays if reclamation of brine is enabled in Step 3CS. Use the ▲ or ▼ buttons to select the number of minutes to divert the brine waste water to the brine tank. After the minutes count down to zero the waste water will once again be diverted to the plumbing drain receptacle.

Press NEXT to go to Step 6CS. Press REGEN to return to previous step.

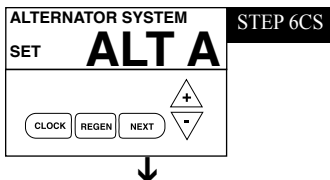

STEP 6CS –Twin Alternating System – Allows automatic alternation between two units to provide softened water 24 hours a day. Use ▲ or ▼ buttons to select ALT A or ALT B. Selection requires connection to a MAV is made. Select ALT A for the control valve that has the two pin connector labeled DRIVE connected to the MAV (motorized alternator valve). Select ALT B for the control valve that will not be connected to the alternator valve motor.

Must do one of the following:

- If set up for a softener, Volume Capacity in GALLONS, select Regeneration Time Option “IMMEDIATE” and select DAYS BETWEEN REGEN “OFF”.
- For additional programming information, refer to MAV manual.

Press NEXT to go to Step 7CS. Press REGEN to return to previous step.

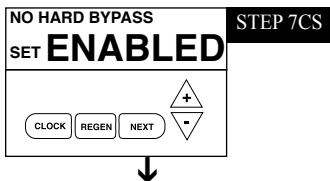

STEP 7CS – No Hard Water Bypass Enabled - Use ▲ or ▼ buttons to select NO HARD WATER BYPASS ENABLE. Selection requires that a connection to a Motorized Alternator Valve (MAV) is made to the two pin connector labeled ALTERNATOR DRIVE located on the printed circuit board. The MAV will be driven closed before the first regeneration cycle that is not FILL or SOFTENING or FILTERING, and be driven open after the last regeneration cycle that is not FILL.

Press NEXT to go to Step 8CS. Press REGEN to return to previous step.

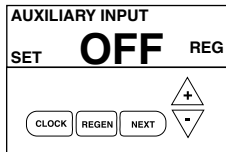

STEP 8CS

STEP 8CS – If Twin Alternating capability is selected, auxiliary input option is not available. This display will be available to select the use of an outside signal to control the initiation of a regeneration. Selection only matters if a connection is made to the two pin connector labeled DP SWITCH located on the printed circuit board. Following is an explanation of the options:

- ON 0 REG – If the dP switch is closed for an accumulative time of 2 minutes, a regeneration will occur immediately.
- DELAY REG – If the dP switch is closed for an accumulative time of 2 minutes, a regeneration will occur at the schedule regeneration time.
- HOLD REG – If the dP switch is closed a regeneration will be prevented from occurring.
- **OFF**

Press NEXT to go to Step 9CS. Press REGEN to return to previous step.

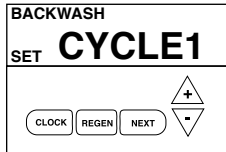

STEP 9CS

STEP 9CS – Press the ▲ or ▼ buttons until selection of first cycle appears in left upper corner, in this example BACKWASH is selected. Press NEXT to go to Step 10CS. Press REGEN to return to previous step.

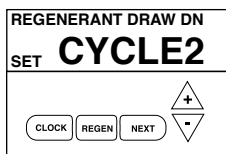

STEP 10CS

STEP 10CS – Press the ▲ or ▼ buttons until selection of second cycle appears in left upper corner, in this example Regenerant Draw DN is selected. For a PM6 control valve prior to selecting DN or UP or not selecting a regenerant flow cycle, verify the correct valve body, main piston, regenerant piston and stack are being used and the injector or injector plug(s) are in the correct location. Press NEXT to go to Step 11CS. Press REGEN to return to previous step.

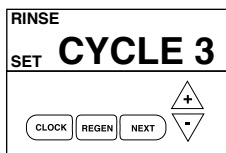

STEP 11CS

STEP 11CS – Press the ▲ or ▼ buttons until selection of third cycle appears in left upper corner, in this example RINSE is selected. Press NEXT to go to Step 12CS. Press REGEN to return to previous step.

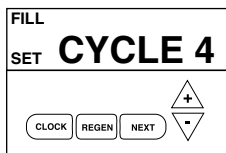

STEP 12CS

STEP 12CS – Press the ▲ or ▼ buttons until selection of fourth cycle appears in left upper corner, in this example FILL is selected. Press NEXT to go to Step 13CS. Press REGEN to return to previous step.

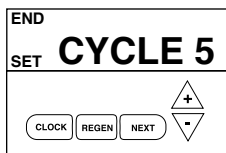

STEP 13CS

STEP 13CS – Press the ▲ or ▼ buttons until last regeneration cycle; END appears. (Up to 9 regeneration modes are possible). **END MUST BE SELECTED AS LAST CYCLE.**

RETURN TO ROTATING DISPLAY

WATER SOFTENER DISINFECTION

The materials of construction of your water softener will not support bacterial growth nor will these materials contaminate a water supply. However, the normal conditions existing during shipping, storage, and installation indicate the advisability of disinfecting a softener after installation, before the softener is used to treat potable water. In addition, during normal use a softener may become fouled with organic matter or in some cases, with bacteria from the water supply.

Therefore, every water softener should be disinfected after installation, some will require periodic disinfection during their normal life. Disinfect as follows:

SODIUM HYPOCHLORITE (household bleach)

5.25% SODIUM HYPOCHLORITE solutions are available under such trade names such as Clorox, Linco, Bo Peep, White Sail and Eagle Brand Bleach. If stronger solutions are used, such as those sold for commercial laundries, adjust the dosage accordingly.

1. Dosage:
 - a. Softening resin; 1.2 fluid ounce per cubic foot of mineral (see page 33).
2. Add the required amount of hypochlorite solution to the brine well of the brine tank.
 - a. Proceed with the normal regeneration. Press regen and allow the water softener to go through a normal regeneration.

WATER SOFTENER DRAINING PROCEDURE

In cold weather climates it is common for plumbing systems that are not in use to be "winterized" or drained of all water to prevent any damage that may be caused by the excessive expansion of water when it freezes. To prevent damage to a water softener it must be **properly** drained also. A simple way to properly drain or winterize a water softener is to use compressed air to force all of the water out of the softener mineral tank. The following procedure will explain the process:

- 1) Initiate the softener into a manual regeneration cycle. Advance control to backwash and allow it to complete the backwash cycle (this will clean the media) and start into the brine-draw cycle. Note: Be sure there is salt in the brine tank and water has been in contact with salt at least 20 minutes. Allow the regeneration to continue in the brine draw cycle until the brine is drawn out of the salt keeper and the air check at the bottom of the brine pick-up tube shuts off. At this time no more brine is introduced into the softener and the slow rinse process begins.
- 2) Turn the water supply inlet and outlet valves off to the water softener as soon as the air check shuts off and no more brine is being drawn into the softener (at the beginning of the slow rinse process).
- 3) Unplug the electric power leaving the softener control valve in the brine draw cycle.
- 4) Remove the brine refill elbow assembly from the control valve. Remove the refill flow control retainer assembly from the elbow. Reinstall the elbow assembly and secure with the locking clip. Disconnect the brine tube at the top of the salt keeper and force air into the brine tube toward the softener mineral tank and control valve. The air will force the brine/water solution that was drawn into the mineral tank out to drain through the control valve drain line. (An air compressor blow gun attachment with a portable air compressor works well.) Reinstall the brine line flow control retainer in side of the refill elbow assembly. Reinstall the brine refill elbow assembly and secure with locking clip.

CAUTION: You do not want to apply any more pressure than necessary to force the brine/water out of the mineral tank.

The small amount of brine/water that may be left in the mineral tank will not expand enough to cause any damage to the softener when it freezes.

If your softener is equipped with an optional bottom drain on the mineral tank, you will have to follow all of the same procedures with the exception of the need for compressed air. With the brine tube disconnected from the salt keeper, raise it to a level above the softener control valve and temporarily secure it in this position. Now open the drain valve at the bottom of the mineral tank and allow all brine/water to drain from the mineral tank.

CAUTION: If a hose is connected to the drain valve to direct the brine/water to a floor drain be sure it runs downward and is unobstructed. When brine/water quits running at the drain, be sure to leave the drain valve open until you start the system up again.

- 5) At this time the salt keeper has very little water left in it. What liquid is left in the salt keeper is saturated brine, provided that there is still salt left in the tank. Saturated brine will not freeze solid and cause any damage and does not have to be drained any further from the brine tank.

If there is no salt left in the salt keeper when the system is drained we recommend dumping all of the water out of the brine tank at this time. See brine tank cleaning instructions. (#2 in miscellaneous section, below)

- 6) **CAUTION:** It is important at this time to be assured that the inlet/outlet water supply piping is properly drained. Depending on how the water supply piping was routed to the water softener control valve, a water loop or trap may have been created.

Sometimes drain valve(s) are installed at the bottom of the loop to assure all water can be drained out. If not it may be necessary to disconnect the control valve from the piping system and open the inlet/outlet valve(s) to allow all the water to drain from the piping. This should be done when the rest of the plumbing system is drained.

- 7) Draining or winterizing of your softener is complete. Refer to the start-up procedures on page 8 when you are ready to start your softener.

MISCELLANEOUS

1. Salt Usage: See your water conditioning professional for a recommendation on the best type of salt for your application.
2. Brine Tank Cleaning:
 - a. Remove brine tank cover.
 - b. Scoop out as much old salt as possible.
 - c. Disconnect brine tubing from safety brine valve at brine well.
 - d. Remove safety brine valve from brine well.
 - e. Place one hand in brine well to hold overflow nut and remove 2 piece overflow.
 - f. Remove optional brine well and grid plate, if used, from brine tank.
 - g. Remove any remaining salt and/or impurities from brine tank.
 - h. Using clean water and a brush or rag, wipe and rinse inside of brine tank. Also wipe and rinse the grid plate and brine well.
 - i. Reassemble brine tank reversing steps c - f. Note: If grid plate is used and it is damaged or cracked, replace with new one.
 - j. Put brine tank in place making sure there is no debris or foreign material beneath it.
 - k. Reconnect brine tubing to safety brine valve.
 - l. Manually add 6 inches of water to the brine tank (or to approximately 1" above the grid plate, if used).
 - m. Add new salt. Important: Do not add the old salt which was removed earlier unless it is clean and not mushy. We recommend using new salt.
 - n. Follow the disinfection instructions found at the top of this page.
 - o. Put on brine tank cover.

TROUBLE SHOOTING

PROBLEM	CAUSE	CORRECTION
1. ERROR followed by code number		
Error Code 101 - Unable to recognize start of regeneration	A1. Not reading piston position, valve has been recently serviced A2. Incorrect Assembly	A1. Resynchronize software with piston position, Press NEXT & REGEN for 3 seconds or until display is blank A2. Disassemble drive bracket, verify wires are in guides & reassemble. Verify motor is plugged into PC board
Error Code 102 - Unexpected stall	B. Mechanical Binding	B. Check piston and spacer stack assembly for foreign matter
Error Code 103 - Motor ran too long, timed out trying to reach next cycle position	C. High drive forces on piston	C. Loosen drive cap gear 1/4 turn or replace Address high drive forces.
Error Code 104 - Motor ran too long, timed out trying to reach home position	D1. Control valve piston not in home position D2. Motor not inserted fully to engage pinion, motor wires broken or disconnected, motor failure D3. Drive gear label dirty or damaged, missing or broken gear D4. Drive bracket incorrectly aligned to back plate D5. PC board is damaged or defective D6. PC board incorrectly aligned to drive bracket	D1. Press NEXT and REGEN for 3 seconds or until display is blank. D2. Check motor and wiring. Replace motor if necessary D3. Replace or clean drive gear D4. Reseat drive bracket D5. Replace PC board D6. Ensure PC board is correctly snapped on to drive bracket
If other Error Codes display contact the factory	E. Incorrect programming. If programmed for any MAV use, MAV must be connected to PC board prior to powering up. F. MAV Stalled	E. Verify MAV drive cable and/or interconnect cable is connected to PC. If no auxilliary valve required, program auxilliary control valve as off. F. Check MAV piston/stack for foreign matter, incorrect assembly, motor not fully inserted or damaged gears
MAV Error Codes: Error Code 106		
Error Code 107		
2. Control valve stalled in regeneration	A. Motor not operating B. No electric power at outlet C. Defective transformer D. Defective PC board E. Broken drive gear or drive cap assembly F. Broken piston retainer G. Broken main or regenerant piston	A. Replace Motor B. Repair outlet or use working outlet C. Replace transformer D. Replace PC board E. Replace drive gear or drive cap assembly F. Replace drive cap assembly G. Replace main or regenerant piston
3. Control valve does not regenerate automatically when REGEN button is depressed and held	A. Transformer unplugged B. No electric power at outlet C. Broken drive gear or drive cap assembly D. Defective PC board	A. Connect transformer B. Repair outlet or use working outlet C. Replace drive gear or drive cap assembly D. Replace PC board
4. Control valve does not regenerate automatically but does when REGEN button is depressed	A. Bypass valve in bypass position B. Meter connection disconnected C. Restricted/stalled meter turbine D. Defective meter E. Defective PC board F. Set-up error	A. Put control valve in service position B. Connect meter to PC board C. Remove meter and check for rotation or foreign matter D. Replace meter E. Replace PC board F. Check control valve set-up procedure
5. Time of day flashes on and off	A. Battery back-up maintains time-of-day up to 2 years in event of power outage and battery is not depleted. Time of day flashes when battery is depleted. B. Prior to 2/2007, PC board did not have battery back-up - capacitor held time of day up to 2 hours. Power outage > 2 hours.	A. Reset time of day and replace battery on PC Board (Lithium coin type battery 2032) B. Reset time of day.
6. Softener delivers hard water.	A. Bypass valve is open or faulty. B. No salt or low salt level in brine tank. C. Softener fails to draw brine. D. Excessive water usage. E. Insufficient brine level in brine tank. F. Resin level inadequate. G. Meter faulty. H. Raw water hardness fluctuation.	A. Close bypass valve or replace. B. Add salt to brine tank and maintain salt level above water level. C. See problem #11. D. Check gallon capacity settings. E. Check brine refill setting and refill flow restrictor for blockage. F. See problem #8, page 21. G. Test meter and clean or replace meter. H. Test raw water hardness and adjust settings to highest known hardness.
7. Unit uses too much salt.	A. Improper brine refill setting. B. Improper settings.	A. Check brine refill setting for proper salt dosage B. Check water hardness and reevaluate capacity setting specification

TROUBLE SHOOTING

PROBLEM	CAUSE	CORRECTION
8. Loss of resin.	<ul style="list-style-type: none"> A. Backwash controller missing. B. Faulty distributor tube assembly. C. Air in water supply system. 	<ul style="list-style-type: none"> A. Install backwash controller. B. Check distributor tube assembly for cracks or holes. C. <ul style="list-style-type: none"> 1. Check for leaks in brine lines, fittings, or air check. Repair or replace. 2. Install upper distributor. 3. Ensure that water supply system has an air eliminator.
9. Softener delivers salt water.	<ul style="list-style-type: none"> A. Low water pressure. B. Excessive water in brine tank. C. Wrong size injector. 	<ul style="list-style-type: none"> A. Check incoming water pressure - Must remain at minimum of 25 psi. B. See problem #11. C. Install correct injector.
10. Excessive water in brine tank.	<ul style="list-style-type: none"> A. Plugged injector. B. Faulty piston assembly. C. Plugged or kinked drain line. D. Backwash flow controller closed off. E. Defective brine line flow control. 	<ul style="list-style-type: none"> A. Remove injector and clean ports. B. Replace piston assembly. C. Inspect drain line for kinks or plugging. D. Check backwash flow controller. E. Replace brine refill flow control.
11. Softener fails to draw brine.	<ul style="list-style-type: none"> A. Injector is plugged. B. Faulty piston assembly. C. Brine line connection leak. D. Drain line plugged creating excess back pressure. E. Drain line too long or too high F. Low inlet pressure. 	<ul style="list-style-type: none"> A. Remove injector and clean ports. B. Check piston assembly. C. Inspect brine line during refill cycle for leaks. D. Inspect drain line for blockage. E. Refer to drain line specifications. F. Increase inlet pressure to a minimum of 25 psi.
12. Continuous flow to drain.	<ul style="list-style-type: none"> A. Piston assembly failure. B. Motor failure. C. Circuit board failure. 	<ul style="list-style-type: none"> A. Replace piston assembly. B. Replace motor. C. Replace circuit board.
13. Loss of water pressure.	<ul style="list-style-type: none"> A. Iron build-up in resin. B. Resin bed fouled with sand or sediment. C. Resin bed mushing due to high amount of oxidizers in water supply (chlorine). 	<ul style="list-style-type: none"> A. See problem #14. B. Rebed softener and install sediment filter ahead of softener. C. Rebed softener. Install dechlorinator system ahead of softener.
14. Iron in softened water.	<ul style="list-style-type: none"> A. Iron has fouled resin bed. B. Iron is not in a soluble state. C. Prefilter failure. D. Iron level excessive. E. Control fails to regenerate. 	<ul style="list-style-type: none"> A. Use iron reducing resin cleaner to cleanse resin bed, and increase salt dosage or regenerate more frequently. Install an Iron Curtain System ahead of the softener. B. Test water to determine type of iron, install iron reduction system. C. Check prefilter. D. Install iron reduction system. E. See problem #4.
15. Absent or incomplete LED display	<ul style="list-style-type: none"> A. Transformer unplugged B. No electric power at outlet C. Defective transformer D. Short in meter E. Defective PC board 	<ul style="list-style-type: none"> A. Plug transformer into uninterrupted outlet B. Repair outlet or use working outlet C. Replace transformer D. Unplug meter from PC board, if LED display lights appropriately, replace meter E. Replace PC board
16. Control does not display correct time of day	<ul style="list-style-type: none"> A. Power outage > 2 years B. Power outage < 2 years, time of day flashing, battery depleted 	<ul style="list-style-type: none"> A. Reset time of day B. Replace lithium coin type battery on circuit board Model 2032 battery
17. No "softening" or "filtering" display when water is flowing	<ul style="list-style-type: none"> A. Bypass valve in bypass position B. Meter connection disconnected C. Restricted/stalled meter turbine D. Defective meter E. Defective PC board 	<ul style="list-style-type: none"> A. Put bypass valve in service position B. Connect meter to PC board C. Remove meter and check for rotation, clean foreign material D. Replace meter E. Replace PC board
18. Control valve regenerates at wrong time of day	<ul style="list-style-type: none"> A. Power outages > 24 hours B. Time of day not set correctly C. Time of regeneration incorrect D. Control valve set at "immediate regeneration" E. Control valve set at "Delay + Immediate" 	<ul style="list-style-type: none"> A. Reset control valve to correct time of day B. Reset to correct time of day C. Reset regeneration time D. Check control valve set-up procedure regeneration time option (see programming options, page 11) E. Check control valve set-up procedure regeneration time option (see programming options, page 11)

RELAY TROUBLESHOOTING

PROBLEM	CAUSE	CORRECTION
20. Relay does not energize		
A. Relay driver programmed on "Time"	A. Programmed incorrectly B. Faulty wire connections between PC board and relay C. Defective PC Board D. Defective relay, See figure below	A. Reprogram, see page 11 B. Check and repair wire connections C. Replace PC Board D. Replace Relay
B. Relay driver programmed on "Gallons"	A. Programmed incorrectly B. Defective PC Board C. Defective relay, See figure below D. Faulty meter connection E. Faulty wire connections between PC board and relay	A. Reprogram, see page 11 B. Replace PC Board C. Replace Relay D. Repair or replace meter assembly E. Check and repair wire connections

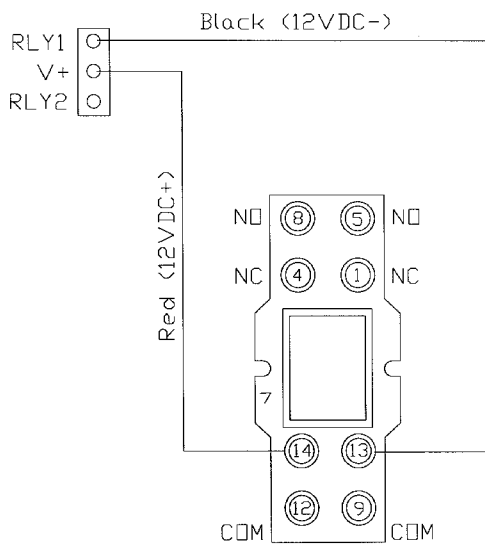

H125 CONDITIONER & SALT KEEPER ASSEMBLIES

Item	Description	Qty	Part #																								
1	Control Center-Metered	1	151-VWS1.25-ED (see pages 20-21 for detailed components)																								
2	Top Diffuser	1	9-D1203-02																								
3&4	Mineral Tank Assembly		<table border="0"> <tr> <td><u>Item 3 only</u></td> <td><u>Item 4 only</u></td> <td></td> </tr> <tr> <td>Mineral Tank</td> <td>Distributor Assy</td> <td>Tank Assy</td> </tr> <tr> <td>H125-32-10 10 x 44</td> <td>19-EN1044NAT</td> <td>9-D780D2A68</td> </tr> <tr> <td>H125-48 10 x 54</td> <td>19-EN1054NAT</td> <td>9-D780D2A68</td> </tr> <tr> <td>H125-64 13 x 54</td> <td>19-WC1354NAT</td> <td>9-D780D2A68</td> </tr> <tr> <td>H125-96 14 x 65</td> <td>19-WC1465NAT</td> <td>9-D780D2A68</td> </tr> <tr> <td>H125-128 16 x 65</td> <td>19-WC1665NAT-4</td> <td>9-T061416</td> </tr> <tr> <td>H125-160 18 x 65</td> <td>19-WC1865NAT-4</td> <td>9-T061824</td> </tr> </table>	<u>Item 3 only</u>	<u>Item 4 only</u>		Mineral Tank	Distributor Assy	Tank Assy	H125-32-10 10 x 44	19-EN1044NAT	9-D780D2A68	H125-48 10 x 54	19-EN1054NAT	9-D780D2A68	H125-64 13 x 54	19-WC1354NAT	9-D780D2A68	H125-96 14 x 65	19-WC1465NAT	9-D780D2A68	H125-128 16 x 65	19-WC1665NAT-4	9-T061416	H125-160 18 x 65	19-WC1865NAT-4	9-T061824
<u>Item 3 only</u>	<u>Item 4 only</u>																										
Mineral Tank	Distributor Assy	Tank Assy																									
H125-32-10 10 x 44	19-EN1044NAT	9-D780D2A68																									
H125-48 10 x 54	19-EN1054NAT	9-D780D2A68																									
H125-64 13 x 54	19-WC1354NAT	9-D780D2A68																									
H125-96 14 x 65	19-WC1465NAT	9-D780D2A68																									
H125-128 16 x 65	19-WC1665NAT-4	9-T061416																									
H125-160 18 x 65	19-WC1865NAT-4	9-T061824																									
5	Ion Exchange Resin	*	341-001 Standard 8% Resin *See Specifications for amount																								
		*	341-001-P Premium 8% Resin *See Specifications for amount																								
6	Underbedding	*	1-A8072 *See Specifications for amount																								
7	3/8" x 6' Brine Line	1	2-H1023-06																								
7-15 a	18X40 w/474 SBV & 5" Grid	1	3-S315-3-C																								
b	18X40 w/474 SBV & 8" Grid	1	3-S335-3-C																								
c	18X40 w/474 SBV & 11" Grid	1	3-S355-3-C																								
d	24x41w/474 SBV & 6" Grid	1	3-S425-3																								
e	24x50 w/474 SBV & 6" Grid	1	3-S525-3																								
f	24x50 w/474 SBV & 9" Grid	1	3-S545-3																								
g	18x40 w/474 SBV & No Grid	1	3-S305-3-C																								
h	24x41 w/474 SBV & No Grid	1	3-S405-3																								
i	24x50 w/474 SBV & No Grid	1	3-S505-3																								
j	30x50 w/474 SBV & No Grid	1	3-S605-3																								
8 a	18x40 Salt Keeper Tank-Black	1	2-1840BK																								
b	24x41 Salt Keeper Tank-Black	1	2-2441BK																								
c	24x50 Salt Keeper Tank-Black	1	2-2450BK																								
d	30x50 Salt Keeper Tank-Black	1	2-3050BK																								
9	Cover 18" BT	1	2-G2191-60																								
	Cover 24" BT	1	2-G2194																								
10-14 a	Safety Brine Valve Assy 41"		2-H4700-39																								
b	Safety Brine Valve Assy 50"		2-H4700-46																								
10	Cap, Brine Well-4"	2	2-H7016																								
11*	Safety Brine Valve	1	2-H4600																								
12	Float Assembly	1	2-H4640-32																								
13	Air Check (474)	1	2-H4500-48																								
14 a	Brine Well 40"-41"	1	2-H1030-36S																								
b	Brine Well 50"	1	2-H1030-46S																								
15	2-Piece Overflow	1	2-H1018																								
16 a	Grid Plate 18" (optional)	1	2-H1072-01																								
b	Grid Plate 24" (optional)	1	2-H002																								
-	Owners Manual	1	73-361-HP																								
-	Twin Brine Tank Tee	1	79-1004																								

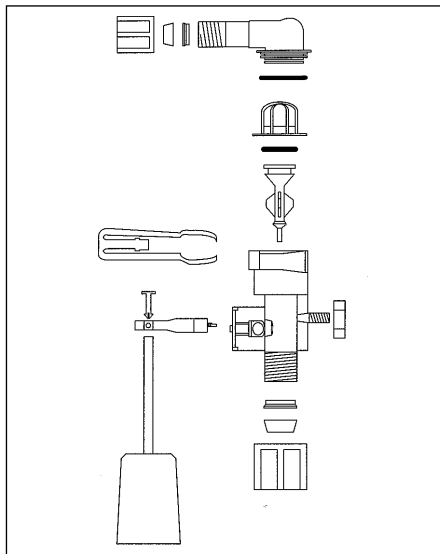

*Safety Brine Valve (Item 11)

Drawing for service only. Must be ordered complete.

Figure 13

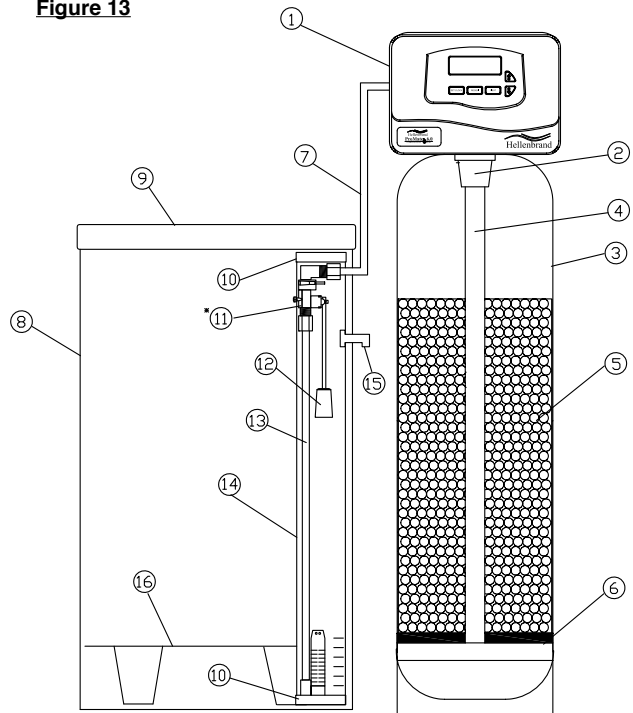

FRONT COVER AND DRIVE ASSEMBLY

DRAWING NO.	ORDER NO.	DESCRIPTION	QUANTITY
1	15-V3529-01-H125	Front Cover Assembly Black	1
2	15-V3107-01	Motor Assembly	1
3	15-V3106-01	Drive Bracket & Spring Clip	1
4	15-V3578HP	H125 PC Board	1
5	15-V3110	Drive Gear 12x36	3
6	15-V3109	Drive Gear Cover	1
Not Shown	99-316-A001-K	Optional Relay Kit-PCM	1
Not Shown	99-316-A002-K	Optional Relay Kit-120V Pigtail	
Not Shown	15-V3009	Auxilliary Switch Kit	

RELAY MODEL AND DESCRIPTION	
Relay Socket	65-SH2B-O5C (2 pole socket)
Relay	65-RH2B-VT DC12V (12V DC DPDT magnetic relay)

Relay Specifications: To insure proper fit and correct operation the following relay and relay socket manufactured by Idec or the exact equivalent should be used.

WIRING FOR CORRECT ON/OFF OPERATION	
PC Board Relay Terminal Block	Relay Socket
RLY 1	#13
V+ (Center)	#14
RLY 2 (Bottom)	

The relay supplies 2 sets of dry contacts for user applications. The wiring of these contacts is application specific.

NOTE: Board Revision 219 and higher - there is a connection for twin alternating system.

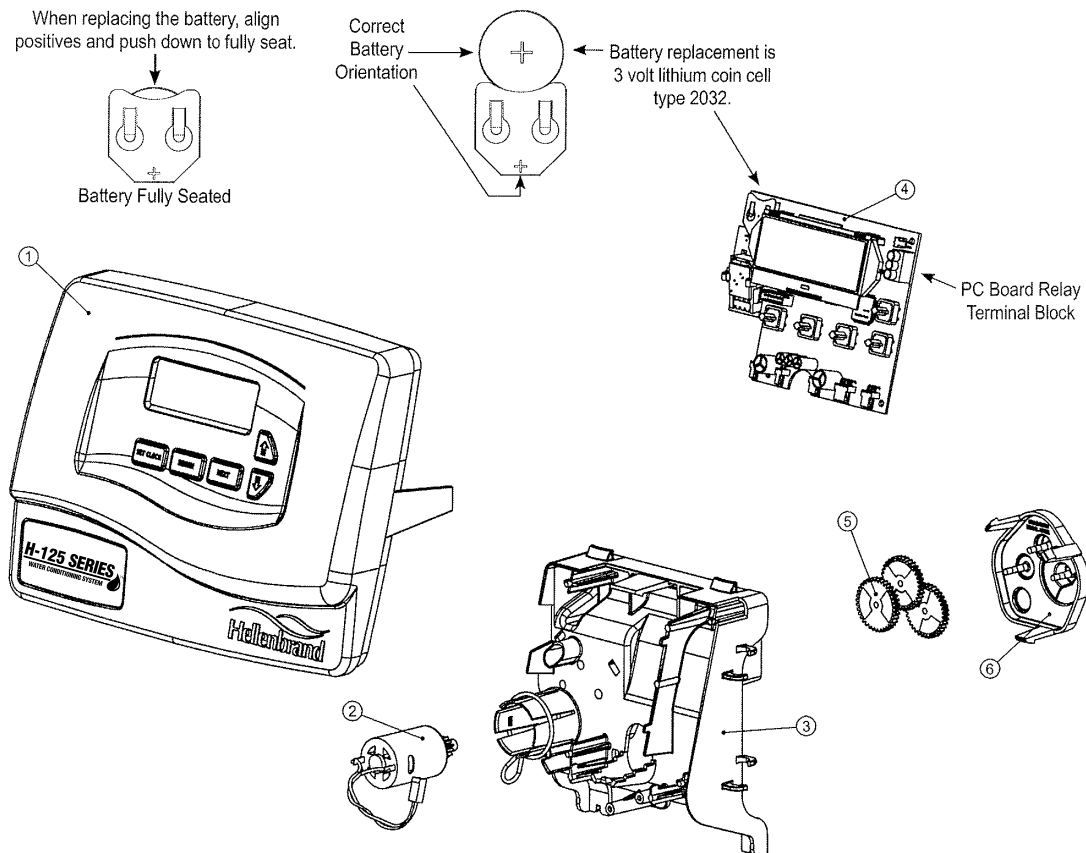

DRIVE CAP ASSEMBLY, DOWN FLOW PISTON, REGENERANT PISTON AND SPACER STACK ASSEMBLY

DRAWING NO.	ORDER NO.	DESCRIPTION	QUANTITY
1	151-V3430	H125 Spacer Stack Assembly	1
2	15-V3004	Drive Cap Assembly	1
3	15-V3343	H125 Drive Back Plate	1
4	151-V3407	H125 Piston Downflow Assy	1
5	15-V3174	Regenerant Piston	1
6	15-V3135	O-ring 228	1
7	15-V3180	O-ring 337	1
8	151-V3358	O-ring 219 (Dist. Tube Opening 1.32")	1

Note: The regenerant piston is not used in backwash only application.

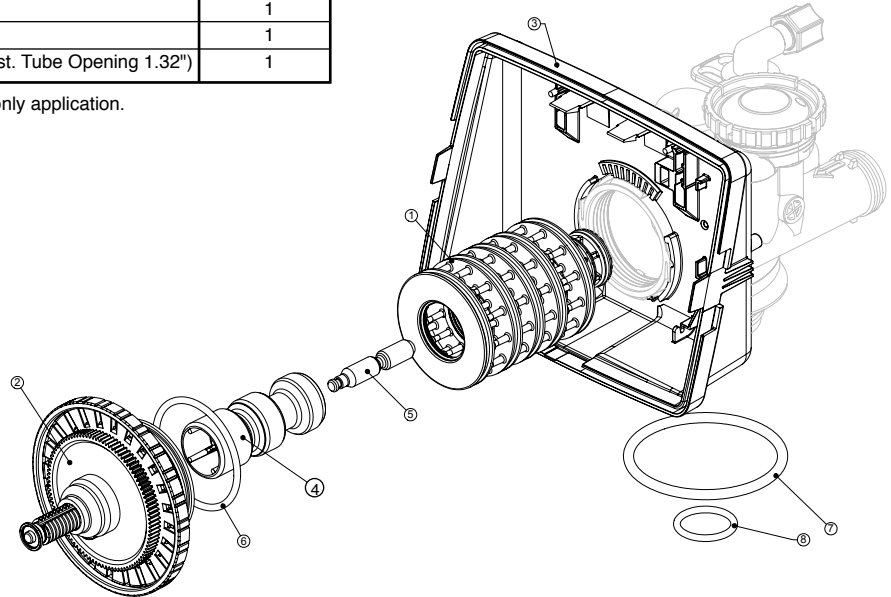

INJECTOR CAP, INJECTOR SCREEN, INJECTOR, PLUG AND O-RING

DRAWING NO.	ORDER NO.	DESCRIPTION	QUANTITY
1	15-V3176	Injector Cap	1
2	15-V3152	O-ring 135	1
3	15-V3177	Injector Screen	1
4	15-V3010-1Z	Injector Assembly Z Plug	1
5	15-V3010-1A	Injector Assembly A Black	1
	15-V3010-1B	Injector Assembly B Brown	
	15-V3010-1C	Injector Assembly C Violet	
	15-V3010-1D	Injector Assembly D Red	
	15-V3010-1E	Injector Assembly E White	
	15-V3010-1F	Injector Assembly F Blue	
	15-V3010-1G	Injector Assembly G Yellow	
	15-V3010-1H	Injector Assembly H Green	
	15-V3010-1I	Injector Assembly I Orange	
	15-V3010-1J	Injector Assembly J Light Blue	
15-V3010-1K	Injector Assembly K Light Green		
Not Shown	15-V3170	O-ring 011	
Not Shown	15-V3171	O-ring 013	

*The injector plug and the injector each contain one 011 (lower) and 013 (upper) o-ring.

Note: For upflow position, injector is located in the up hole and injector plug is in the other hole. H125 upflow bodies are identified by having the DN marking removed. For a filter that only backwashes, injector plugs are located in both holes.

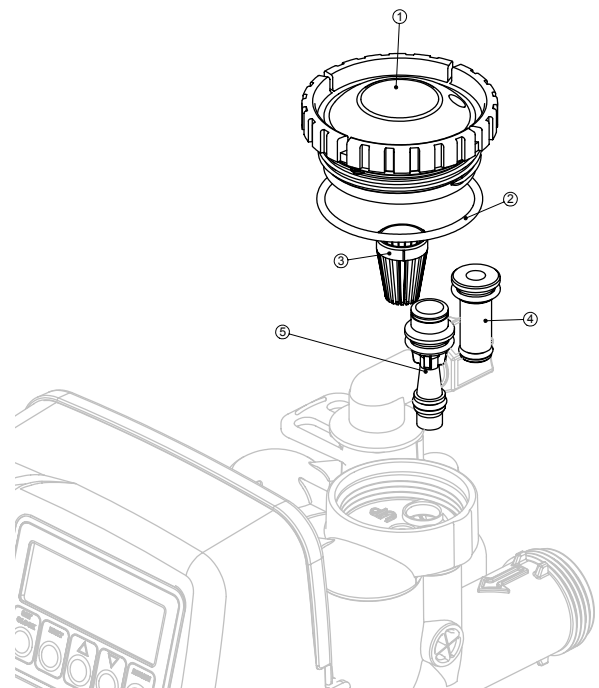

ER NO

15-JCPG-6BLK Nut 3/8

1

Proper flow



DRAIN LINE - 3/4"

ITEM NO.	ORDER NO.	DESCRIPTION	QTY.
1	15-H4615	Elbow Locking Clip	1
2	15-PKP10TS8	Polytube Insert, 5/8"	Option
3	15-V3192	Nut 3/4" Drain Elbow	Option
4-6	15-V3158-01	Drain Elbow 3/4" Male Assy	1
5	15-V3163	O-ring 019	1
6	15-V3159-01	DLFC Retainer Assy.	1
7	15-V3162-007	DLFC 0.7 gpm for 3/4"	1 One DLFC must be used if 3/4" fitting is used
	15-V3162-010	DLFC 1.0 gpm for 3/4"	
	15-V3162-013	DLFC 1.3 gpm for 3/4"	
	15-V3162-017	DLFC 1.7 gpm for 3/4"	
	15-V3162-022	DLFC 2.2 gpm for 3/4"	
	15-V3162-027	DLFC 2.7 gpm for 3/4"	
	15-V3162-032	DLFC 3.2 gpm for 3/4"	
	15-V3162-042	DLFC 4.2 gpm for 3/4"	
	15-V3162-053	DLFC 5.3 gpm for 3/4"	
	15-V3162-065	DLFC 6.5 gpm for 3/4"	
	15-V3162-075	DLFC 7.5 gpm for 3/4"	

Systems are shipped without 3/4" nut for drain elbow (polytube installation only) and 5/8" polytube insert (polytube installation only).

See System Specifications DLFC on page 32, for correct DLFC size for your unit.

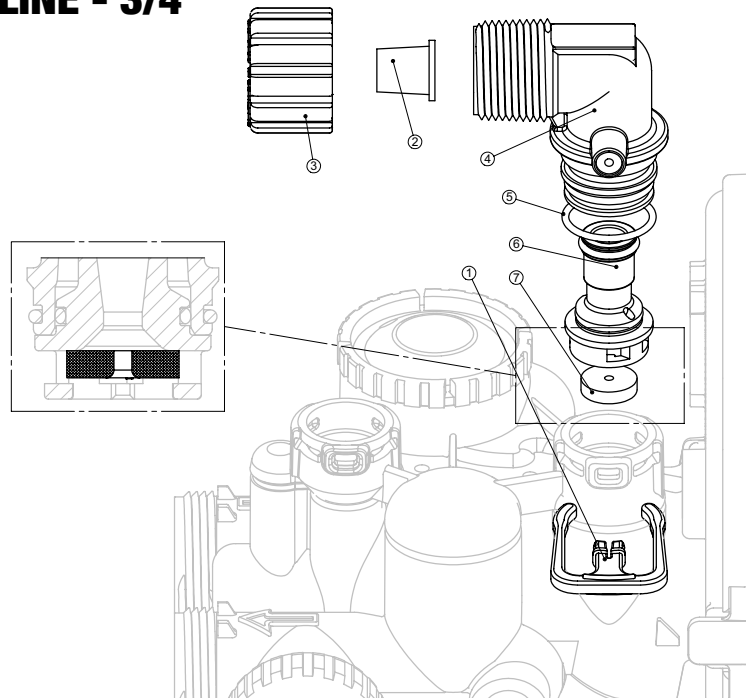

Figure 18

DRAIN LINE - 1"

ITEM NO.	ORDER NO.	DESCRIPTION	QTY.
1	15-H4615	Elbow Locking Clip	1
2-8	15-V3008-02	Drain Ftg, 1" Straight Assy.	1
3*	15-V3166	Drain Ftg Body, 1"	1
4*	15-V3167	Drain Ftg Adapter, 1"	1
5*	15-V3163	O-ring 019	1
6*	15-V3150	Split Ring	1
7*	15-V3151	Nut, 1" QC	1
8*	15-V3105	O-ring 215	1
9	15-V3190-090	DLFC 9.0 gpm for 1"	One DLFC must be used if 1" fitting is used
	15-V3190-100	DLFC 10.0 gpm for 1"	
	15-V3190-110	DLFC 11.0 gpm for 1"	
	15-V3190-130	DLFC 13.0 gpm for 1"	
	15-V3190-150	DLFC 15.0 gpm for 1"	
	15-V3190-170	DLFC 17.0 gpm for 1"	
	15-V3190-200	DLFC 20.0 gpm for 1"	
	15-V3190-250	DLFC 25.0 gpm for 1"	

See System Specifications DLFC on page 32, for correct DLFC size for your unit.

The nuts and caps are designed to be unscrewed or tightened by hand or with the special plastic wrench. If necessary a pliers can be used to unscrew the nut or cap. Do not use a pipe wrench to tighten or loosen nuts or caps. Do not place screwdriver in slots on caps and/or tap with a hammer.

Do not use pipe dope or other sealants on threads. Teflon tape must be used on threads of the 1" NPT connection and on the threads for the drain line connection. Teflon tape is not necessary on the nut connection nor caps because of o-ring seals.

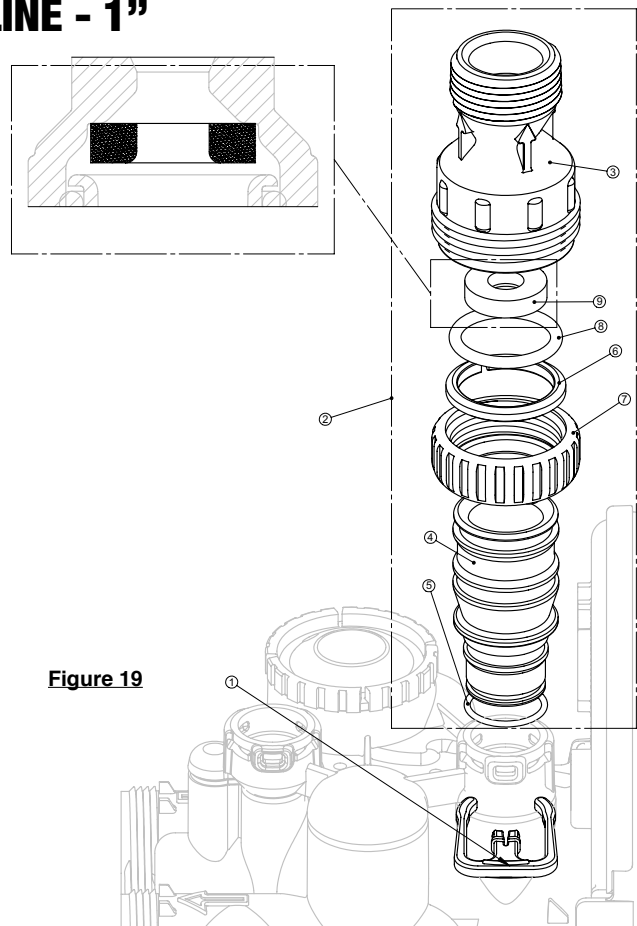

Figure 19

WATER METER AND METER PLUG

ITEM NO.	ORDER NO.	DESCRIPTION	QTY.
1	15-V3151	Nut 1" QC	1
2-4	15-V3003*	Meter Assy.	1
3	15-V3118-01	Turbine Assy.	1
4	15-V3105	O-ring 215	1
5	15-V3003-01	Meter Plug Assy.**	1

*Order number 15-V3003 includes 15-V3118-01 and 15-V3103, which are item numbers 3 & 4.

**Only used if metering is not to be done (time clock units)

The nuts and caps are designed to be unscrewed or tightened by hand or with the special plastic wrench. If necessary a pliers can be used to unscrew the nut or cap. Do not use a pipe wrench to tighten or loosen nuts or caps. Do not place screwdriver in slots on caps and/or tap with a hammer.

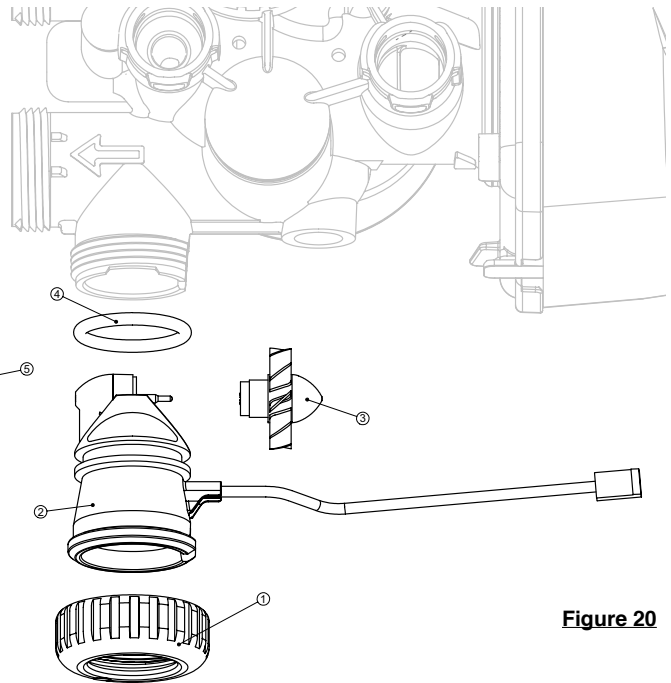
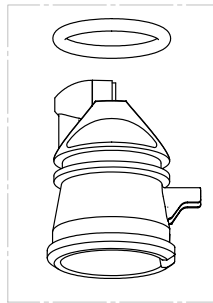

Figure 20

BYPASS VALVE

ITEM NO.	ORDER NO.	DESCRIPTION	QTY.
Not Shown	15-V3191-01	Bypass 90° Vert. Assy.	
1	15-V3151	Nut 1" Quick Connect	2
2	15-V3150	Split Ring	2
3	15-V3105	O-Ring 215	2
Not Shown	15-V3191-01	Bypass Vertical Adpt. Assy (set of 2)	1

The nuts and caps are designed to be unscrewed or tightened by hand or with the special plastic wrench. If necessary a pliers can be used to unscrew the nut or cap. Do not use a pipe wrench to tighten or loosen nuts or caps. Do not place screwdriver in slots on caps and/or tap with a hammer.

Do not use pipe dope or other sealants on threads. Teflon tape must be used on threads of the 1" NPT connection and on the threads for the drain line connection. Teflon tape is not necessary on the nut connection nor caps because of o-ring seals.

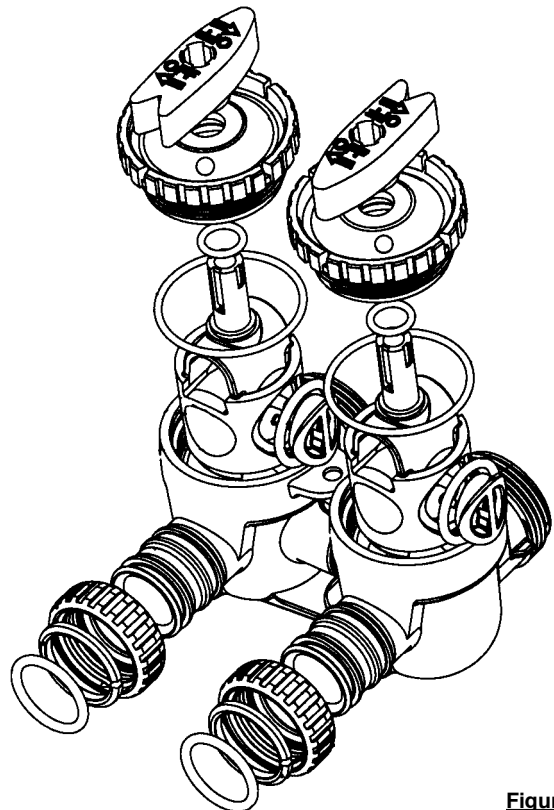
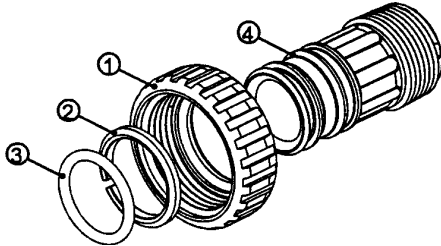

Figure 21

INSTALLATION FITTING ASSEMBLIES

ITEM NO.	ORDER NO.	DESCRIPTION	QTY.
1	15-V3151	Nut 1" Quick Connect	2
2	15-V3150	Split Ring	2
3	15-V3105	O-Ring 215	2
4	15-V3164	Fitting 1" Plastic Male NPT	2
1-4	15-V3007-04	Fitting 1" Male NPT Asy. (Set of 2)	1

Figure 22



ITEM NO.	ORDER NO.	DESCRIPTION	QTY.
1	15-V3151	Nut 1" Quick Connect	2
2	15-V3150	Split Ring	2
3	15-V3105	O-Ring 215	2
4	15-V3317	Fitting 1-1/4" Plastic Male NPT	2
1-4	15-V3007-05	Fitting 1-1/4" Male NPT (Set of 2)	1

Figure 23

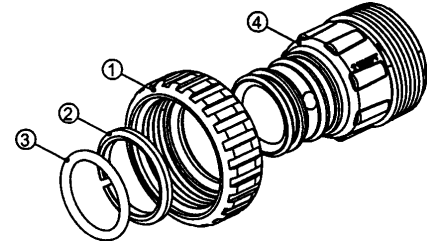

ITEM NO.	ORDER NO.	DESCRIPTION	QTY.
1	15-V3151	Nut 1" Quick Connect	2
2	15-V3150	Split Ring	2
3	15-V3105	O-Ring 215	2
4	15-V3188	Fitting 1" Brass Sweat	2
1-4	15-V3007-02	Fitting 1" Brass Sweat Asy (Set of 2)	1

Figure 24

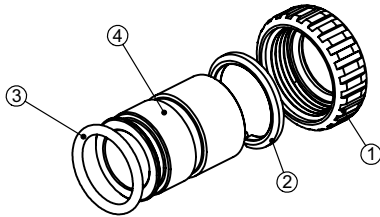

ITEM NO.	ORDER NO.	DESCRIPTION	QTY.
1	15-V3151	Nut 1" Quick Connect	2
2	15-V3150	Split Ring	2
3	15-V3105	O-Ring 215	2
4	15-V3188-01	Fitting 3/4" Brass Sweat	2
1-4	15-V3007-03	Fitting 3/4" Brass Sweat Asy (Set of 2)	1

Figure 25

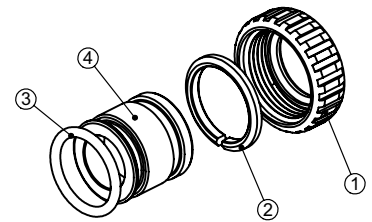

ITEM NO.	ORDER NO.	DESCRIPTION	QTY.
1	15-V3151	Nut 1" Quick Connect	2
2	15-V3150	Split Ring	2
3	15-V3105	O-Ring 215	2
4	15-V3149	Fitting 1" PVC Male NPT Elb.	2
1-4	15-V3007	Fitting 1" PVC Male NPT Asy. (Set of 2)	1

Figure 26

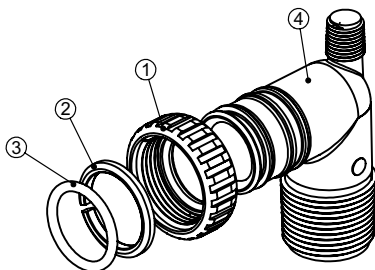

ITEM NO.	ORDER NO.	DESCRIPTION	QTY.
1	15-V3151	Nut 1" Quick Connect	2
2	15-V3150	Split Ring	2
3	15-V3105	O-Ring 215	2
4	15-V3189	Fitting 3/4" & 1" PVC Solv. 90	2
1-4	15-V3007-01	Fitting 3/4" & 1" PVC Solv 90 (set of 2)	1

Figure 27

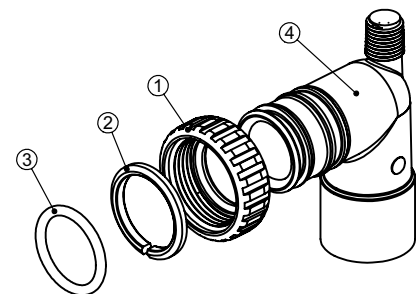

The nuts and caps are designed to be unscrewed or tightened by hand or with the special plastic wrench. If necessary a pliers can be used to unscrew the nut or cap. Do not use a pipe wrench to tighten or loosen nuts or caps. Do not place screwdriver in slots on caps and/or tap with a hammer.

Do not use pipe dope or other sealants on threads. Teflon tape must be used on threads of the 1" NPT connection and on the threads for the drain line connection. Teflon tape is not necessary on the nut connection nor caps because of o-ring seals.

Order No: 15-V3007-12
 Description: IC 2.0 Fitting 3/4" Brass SharkBite Assembly

ITEM NO.	ORDER NO.	DESCRIPTION	QTY.
1	15-V3151	Nut 1" Quick Connect	2
2	15-V3150	Split Ring	2
3	15-V3105	O-Ring 215	2
4	15-V3628	Fitting 3/4" Brass SharkBite	2

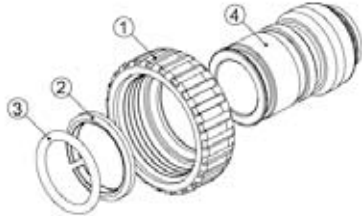

Order No: 15-V3007-13
 Description: IC 2.0 Fitting 1" Brass SharkBite Assembly

ITEM NO.	ORDER NO.	DESCRIPTION	QTY.
1	15-V3151	Nut 1" Quick Connect	2
2	15-V3150	Split Ring	2
3	15-V3105	O-Ring 215	2
4	15-V3629	Fitting 1" Brass SharkBite	2

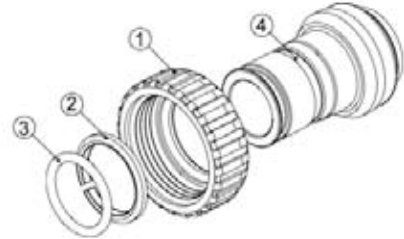

The nuts and caps are designed to be unscrewed or tightened by hand or with the special plastic wrench. If necessary a pliers can be used to unscrew the nut or cap. Do not use a pipe wrench to tighten or loosen nuts or caps. Do not place screwdriver in slots on caps and/or tap with a hammer.

Do not use pipe dope or other sealants on threads. Teflon tape must be used on threads of the 1" NPT connection and on the threads for the drain line connection. Teflon tape is not necessary on the nut connection nor caps because of o-ring seals.

WRENCH

Although no tools are necessary to assemble or disassemble the valve, the wrench (shown in various positions on the valve) may be purchased to aid in assembly or disassembly. **Wrench part number is 15-V3193-02.**

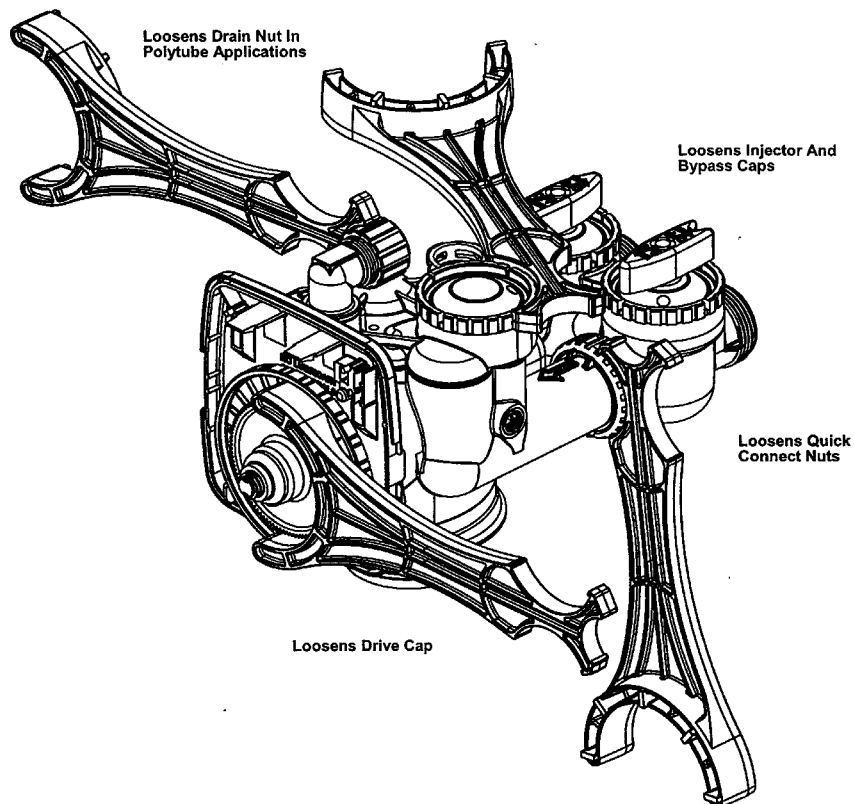

FLOW DIAGRAMS – SERVICE AND BACKWASH

flow diagram...service

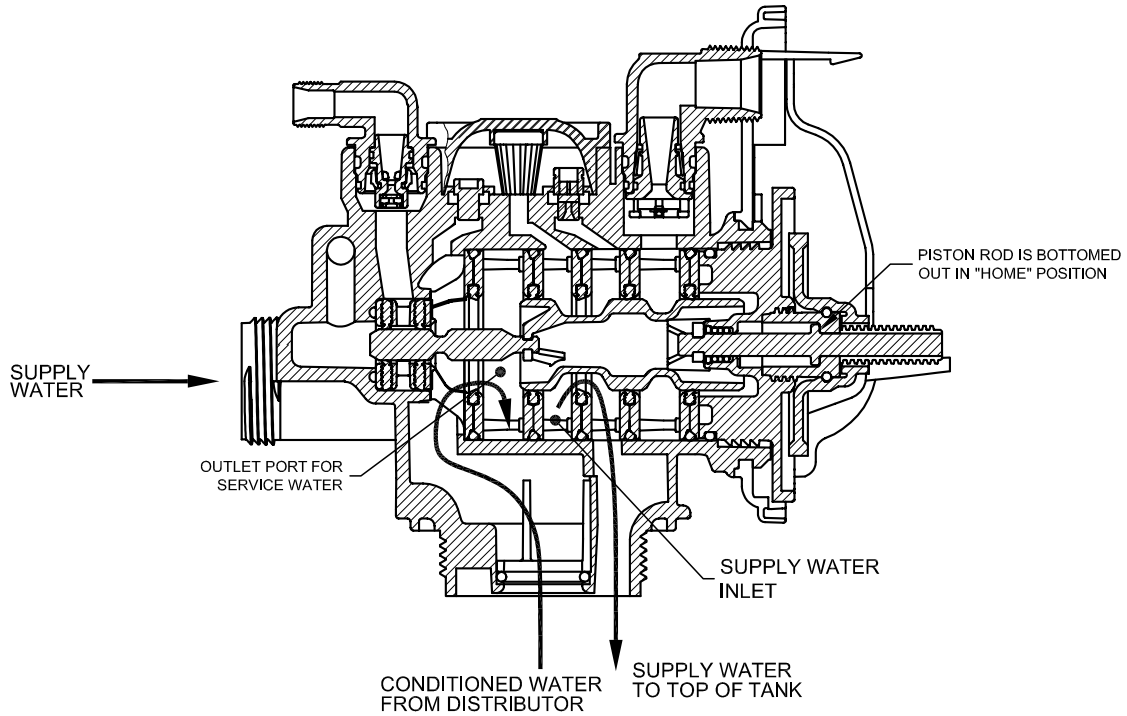

flow diagram...backwash

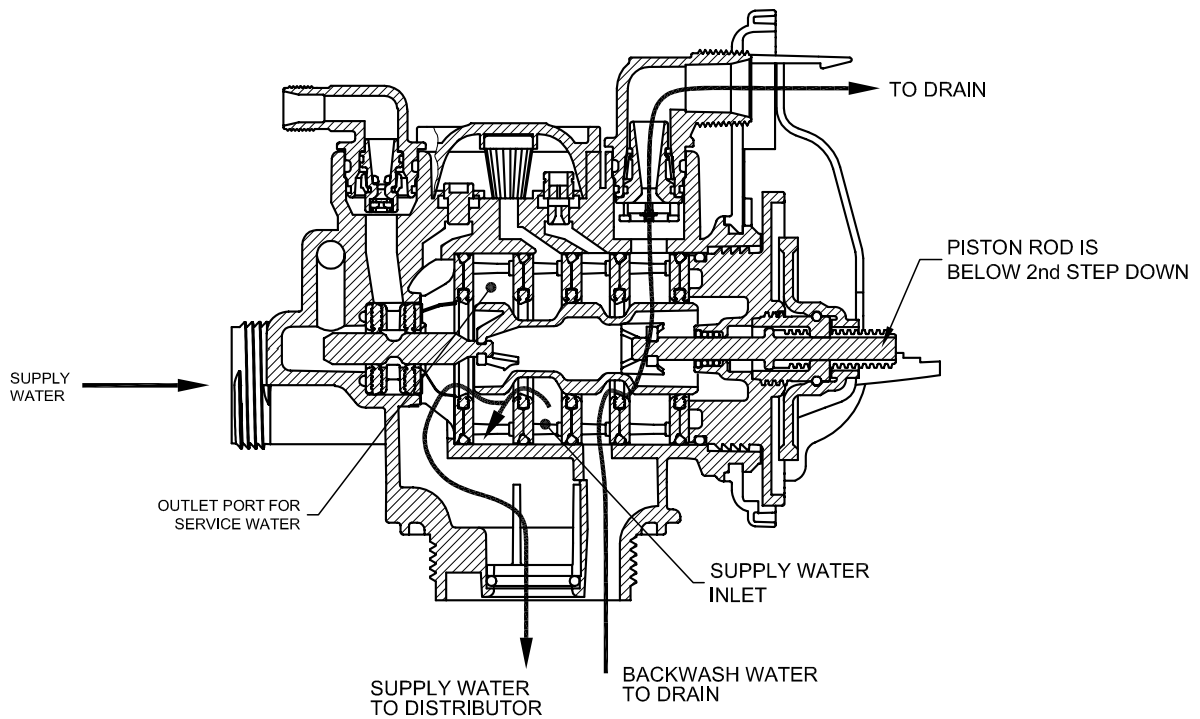

FLOW DIAGRAMS – DOWNFLOW

flow diagram...downflow brine

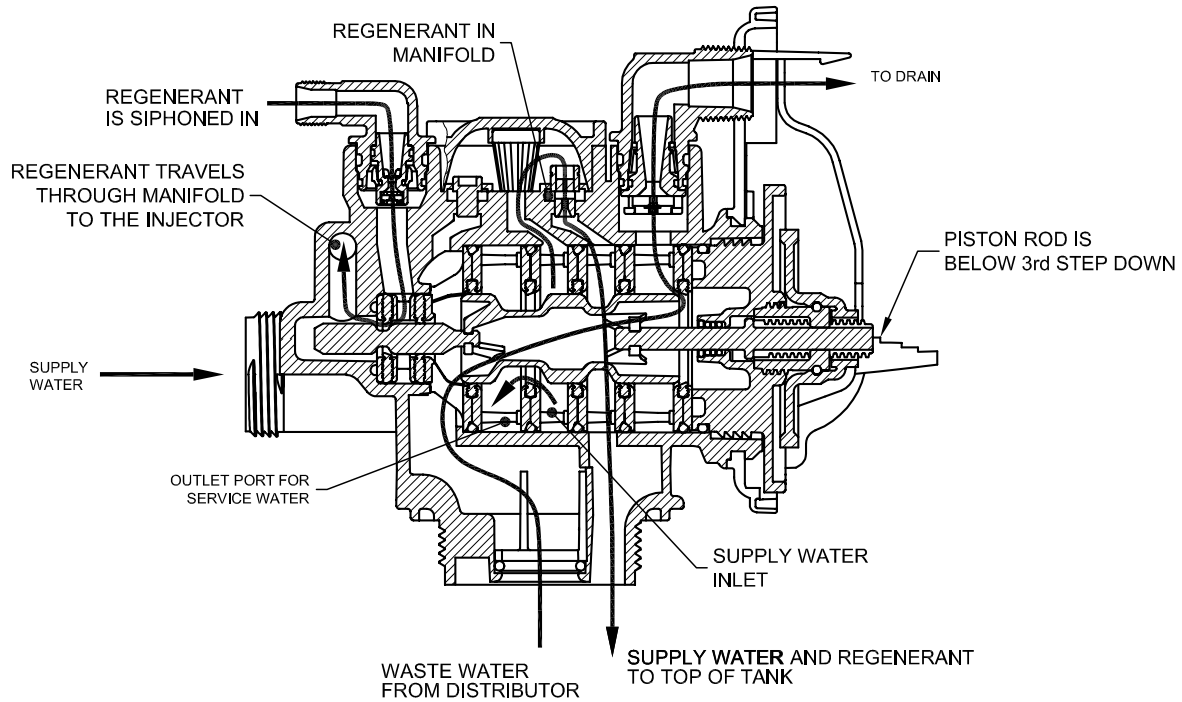

FLOW DIAGRAMS – RINSE AND FILL

flow diagram...rinse

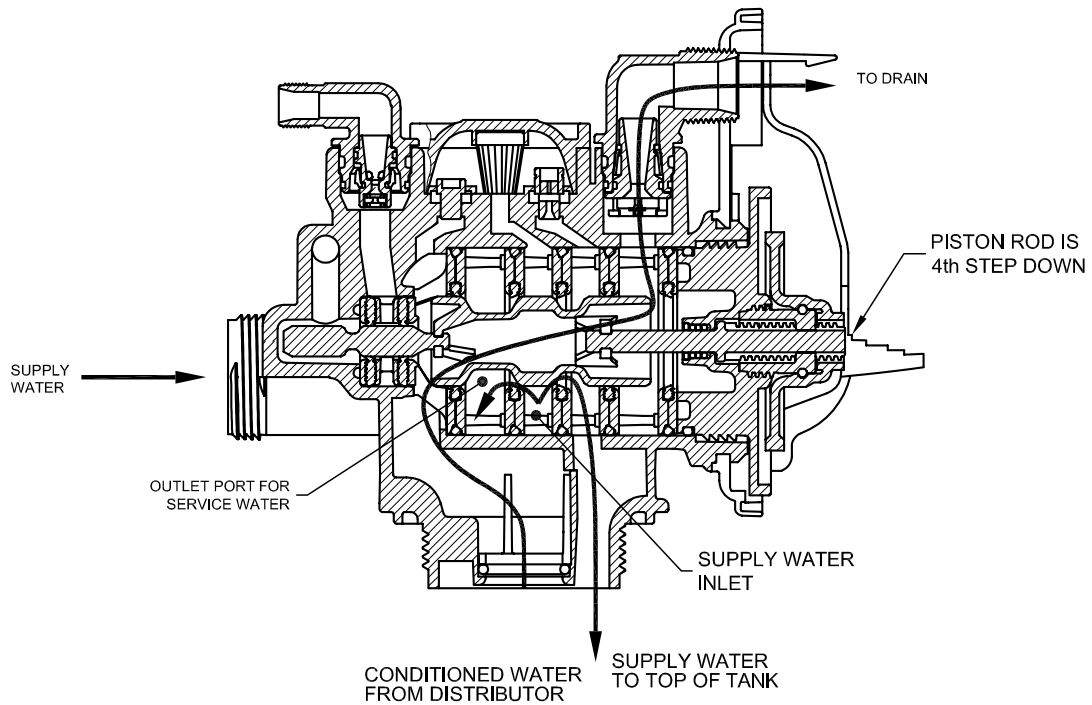

flow diagram...fill

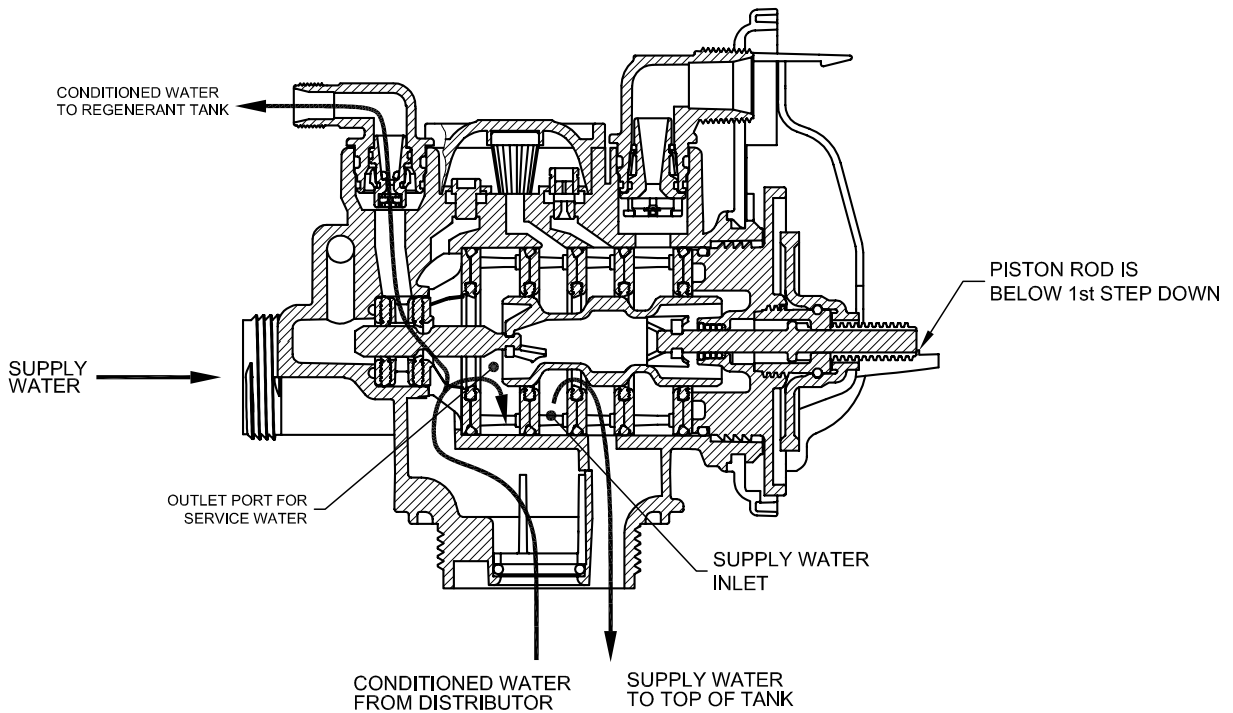

H125 SPECIFICATIONS

Model #	H125	H125	H125	H125	H125	H125	H125
	32-10	48	64	96	128	160	192
Factory Regeneration Settings							
Backwash Minutes	8	8	8	8	8	8	8
Backwash Gallons	18	18	34	34	42	60	60
Brine/Rinse Minutes	60	60	68	68	68	68	68
Brine/Rinse Gallons	19.2	22.2	43.5	47.7	71.1	89.1	113
Backwash Minutes	8	8	8	8	8	8	8
Backwash Gallons	18	18	34	34	42	60	60
Fast Rinse Minutes	4	4	4	4	4	4	4
Fast Rinse Gallons	9	9	17	17	21	30	30
Fill Minutes	6:32	9:53	13:14	19:56	26:38	33:20	40:02
Fill Gallons	3.2	4.7	6.5	9.8	13.2	16.6	20
Total Regeneration Gallons*	66	71	134	142	190	256	283

* Calculations are based on factory medium salt setting @ 50 psi

Refill LBS of salt	Lbs.	Lbs.	Lbs.	Lbs.	Lbs.	Lbs.	Lbs.
Low Salt	6	9	12	18	24	30	36
Medium Salt	10	15	20	30	40	50	60
High Salt	15	22.5	30	45	60	75	90

Capacity	Grains	Grains	Grains	Grains	Grains	Grains	Grains
Low Salt	19,000	28,500	38,000	57,000	76,000	95,000	114,000
Medium Salt	28,000	42,000	56,000	84,000	112,000	140,000	168,000
High Salt	32,000	48,000	64,000	96,000	128,000	160,000	192,000





Service Flow Rates	GPM	GPM	GPM	GPM	GPM	GPM	GPM
Continuous @ 15 psi	22	19	25	24	25	27	26
Peak @ 25 psi	31	28	34	33	34	35	34

Flint Under bed (lbs.)	14	14	40	40	45	50	75
High Capacity Resin (cu.ft.)	1	1.5	2	3	4	5	6
Resin Tank Size	10x44	10x54	13x54	14x65	16x65	18x65	18x65
Recommended Brine Tank	18x40	18x40	18x40	18x40	24x41	24x50	24x50
Brine Line Size	3/8"	3/8"	3/8"	3/8"	3/8"	1/2"	1/2"
DLFC (gpm)	2.2	2.2	4.2	4.2	5.3	7.5	7.5
BLFC (gpm)	0.5	0.5	0.5	0.5	0.5	0.5	0.5
Injector Size	D-Red	E-White	G-Yellow	H-Green	I-Orange	J- Lt. Blue	K- Lt. Green
Injector Draw Rate @ 50 psi	0.22	0.27	0.46	0.46	0.6	0.7	0.7
Injector Slow Rinse @ 50 psi	0.32	0.37	0.64	0.71	1.1	1.4	1.8

PROGRAMMING OPTIONS

Reserve Gallons	Regeneration Type	Days Override	Results (Reserve capacity estimate based on history of water usage)
AUTO	DELAY	oFF	Reserve capacity automatically estimated. Regeneration occurs when gallons capacity falls below the reserve capacity at the next Regen Set Time.
AUTO	DELAY	1 to 28	Reserve capacity automatically estimated. Regeneration occurs at the next Regen Set Time when gallons capacity falls below the reserve capacity or the specified number of days between regenerations is reached.
20 to 250,000	DELAY	oFF	Reserve capacity <u>not</u> automatically estimated. Regeneration occurs at the next Regen Set Time when gallons capacity reaches 0.
oFF	DELAY	1 to 28	Reserve capacity <u>not</u> automatically estimated. Regeneration occurs at the next Regen Set Time when the specified number of days between regenerations is reached.
20 to 250,000	DELAY	1 to 28	Reserve capacity <u>not</u> automatically estimated. Regeneration occurs at the next Regen Set Time when gallons capacity reaches 0 or the specified number of days between regenerations is reached.
AUTO	IMMEDIATE	oFF	Reserve capacity <u>not</u> automatically estimated. Regeneration occurs immediately when gallons capacity reaches 0. Time of regeneration will not be allowed to be set because regeneration will always occur when gallons capacity reaches 0.
20 to 250,000	DELAY + IMMEDIATE	oFF	Reserve capacity <u>not</u> automatically estimated. Regeneration occurs immediately when gallons capacity reaches 0. Time of regeneration will not be allowed to be set because regeneration will always occur on 0.
AUTO	DELAY + IMMEDIATE	oFF	Reserve capacity automatically estimated. Regeneration occurs when gallons capacity falls below the reserve capacity at the next Regen Set Time or regeneration occurs immediately after 10 minutes of no water usage when gallon capacity reaches 0.
AUTO*	DELAY + IMMEDIATE	1 to 28 *14	Reserve capacity automatically estimated. Regeneration occurs at the next Regen Set Time when gallons capacity falls below the reserve capacity or the specified number of days between regenerations is reached or regeneration occurs immediately after 10 minutes of no water usage when gallon capacity reaches 0.
20 to 250,000	DELAY + IMMEDIATE	1 to 28	Reserve capacity <u>not</u> automatically estimated. Regeneration occurs at the next Regen Set Time when specified number of days between regenerations is reached or regeneration occurs immediately after 10 minutes of no water usage when gallon capacity reaches 0.

***Factory settings in bold**

To "lockout" access to modification settings, diagnostic and valve history displays except hardness, day override and time, press  next,  and clock in sequence to "unlock" press  next,  and clock in sequence.

GENERAL SPECIFICATIONS

OPERATING PRESSURES

Minimum/Maximum25 psi-125 psi

OPERATING TEMPERATURES

Minimum/Maximum40° - 110° F

METER

Accuracy.....±5%
Flow Rate Range.....0.25 - 34 GPM
Gallon Range20 - 50,000

DIMENSIONS

Drain Line3/4" or 1" NPT
Brine Line3/8" Poly Tube
Electrical Current Draw and Voltage0.5A 110v

Compatible with the following regenerants or chemicals: Sodium chloride, potassium permanganate, sodium bisulfite, sodium hydroxide, hydroxide, hydrochloric acid, chlorine and chloramines.

SERVICE INSTRUCTIONS

Drive Assembly

Remove the valve cover to access the drive assembly.

Disconnect the power source plug (black wire) from the PC board prior to disconnecting the motor or water meter plugs from the PC board. The power source plug connects to the four-pin jack. The motor plug connects to the two-pin jack on the left-hand side of the PC board. The water meter plug (gray wire) connects to the three-pin jack on the far right-hand side of the PC board.

PC Board Replacement

The PC board can be removed separately from the drive bracket but it is not recommended. Do not attempt to remove the display panel from the PC board. Handle the board by the edges. To remove the PC board from the drive bracket, unplug the power, water meter and motor plugs from the PC board. Lift the middle latch along the top of the drive bracket while pulling outward on the top of the PC board. The drive bracket has two plastic pins that fit into the holes on the lower edge of the PC board. Once the PC board is tilted about 45° from the drive bracket it can be lifted off of these pins. To reinstall a board, push the top of the PC board towards the valve until it snaps under the middle latch, weave the power and water meter wires into the holders and reconnect the motor, water meter and power plugs.

Drive Bracket Replacement

The drive bracket must be removed to access the drive cap assembly and pistons or the drive gear cover. It is not necessary to remove the PC board from the drive bracket to remove the drive bracket. To remove the drive bracket start by removing the plugs for the power source and the water meter. Unweave the wires from the side holders. Two tabs on the top of the drive back plate hold the drive bracket in place. Simultaneously lift the two tabs and gently ease the top of the drive bracket forward. The lower edge of the drive bracket has two notches that rest on the drive back plate. Lift up and outward on the drive bracket to disengage the notches.

To reassemble, seat the bottom of the drive bracket so the notches are engaged at the bottom of the drive back plate. Push the top of the drive bracket toward the two latches. The drive bracket may have to be lifted slightly to let the threaded piston rod pass through the hole in the drive bracket. Maintain a slight engaging force on top of the drive bracket while deflecting the bracket slightly to the left by pressing on the side of the upper right corner. This helps the drive gears mesh with the drive cap assembly. The drive bracket is properly seated when it snaps under the latches on the drive back plate. If resistance is felt before latching, then notches are not fully engaged, the piston rod is not in hold, the wires are jammed between the drive bracket and drive back plate, or the gear is not engaging the drive cap assembly.

Drive Gear Replacement

To inspect the drive gears, the drive gear cover needs to be removed. Before trying to remove the gear cover, the drive bracket must be removed from the drive back plate. (Refer to the instructions above regarding removing the drive bracket from the drive back plate. The drive gear cover can be removed from the drive bracket without removing the motor or the PC board.) The drive gear cover is held in place on the drive bracket by three clips. The largest of the three clips is always orientated to the bottom of the drive bracket. With the

PC board facing up, push in and down on the large clip on the drive gear cover. Handle the cover and the gears carefully so that the gears do not fall off the pegs in the cover.

Replace broken or damaged drive gears. Do not lubricate any of the gears. Avoid getting any foreign matter on the reflective coating because dirt or oils may interfere with pulse counting.

The drive gear cover only fits on one way, with the large clip orientated towards the bottom. If all three clips are outside of the gear shroud on the drive bracket the drive gear cover slips easily into place.

Drive Motor Replacement

The drive bracket does not need to be removed from the drive plate if the motor needs to be removed. To remove the motor, disconnect the power and motor plugs from the jacks on the PC board. Move the spring clip loop to the right and hold. Rotate the motor at least a 1/4 turn in either direction so the wires are vertical (up & down) before gently pulling on the wire connectors to remove the motor. Pulling directly on the wires without rotating the motor may break the wires off the motor.

Replace the motor if necessary. Do not lubricate the motor or the gears. To reinstall the motor, move the spring clip loop to the right and hold. Gently turn the motor while inserting so that the gear on the motor meshes with the gears under the drive gear cover. Release the spring clip loop and continue to rotate the motor until the wires are horizontal and the motor housing engages the small plastic bulge inside the drive bracket motor retainer. Reconnect the motor plug to the two-pronged jack on the lower left side of the PC board. If the motor will not easily engage with the drive gears when reinstalling, lift and slightly rotate the motor before reinserting. Reconnect the power plug.

Replace the valve cover. After completing any valve maintenance, press and hold NEXT and REGEN buttons for 3 seconds or unplug power source jack (black wire) and plug back in. This resets the electronics and establishes the service piston position. The display should flash all wording, then flash the software version and then reset the valve to the service position.

Drive Cap Assembly, Main Piston and Regenerant Piston

The drive assembly must be removed to access the drive cap assembly. The drive cap assembly must be removed to access the piston(s). The drive cap assembly is threaded into the control valve body and seals with an o-ring. To remove the drive cap assembly use the special plastic wrench or insert a 1/4" to 1/2" flat blade screwdriver into one of the slots around the top 2" of the drive cap assembly so it engages the notches molded into the drive back plate around the top 2" of the piston cavity. See Figure 29. The notches are visible through the holes. Lever the screwdriver so the drive cap assembly turns counter clockwise. Once loosened, unscrew the drive cap assembly by hand and pull straight out.

The drive cap assembly contains the drive cap, the main drive gear, drive cap, piston rod and various other parts that should not be disassembled in the field. The only replaceable part on the drive cap assembly is the o-ring. Attached to the drive cap assembly is the main piston and if a regenerant is used, a regenerant piston.

The regenerant piston (the small diameter one behind the main piston) is removed from the main piston by pressing sideways and unsnapping it from its latch. Chemically clean this in dilute sodium bisulfite or vinegar, or replace the regenerant piston if needed. To remove the main downflow or upflow piston fully extend the piston rod and then unsnap the main piston, from its latch by pressing on the side with the number. Chemically clean this in dilute sodium bisulfite or vinegar, or replace the main piston.

Reattach the main piston to the drive cap assembly. Reattach the regenerant piston (if needed) to the main piston. Do not lubricate the piston rod, main piston or regenerant piston. Lubricant will adversely affect the clear lip seals. Reinsert the drive cap assembly and piston into the spacer stack assembly and hand tighten the drive cap assembly. Continue to tighten the drive cap assembly using a screwdriver as a ratchet until the black o-ring on the spacer stack assembly is no longer visible through the drain port. Excessive force can break the notches molded into the drive back plate. Make certain that the main drive gear still turns freely. The exact position of the piston is not important as long as the main drive gear turns freely.

Reattach the drive assembly to the control valve and connect all plugs. After completing any valve maintenance, press and hold NEXT and REGEN buttons for 3 seconds or unplug power source jack (black wire) and plug back in. This resets the electronics and establishes the service piston position. This display should flash all wording, then flash the software version and then reset the valve to the service position.

Spacer Stack Assembly

To access the spacer stack assembly remove the drive assembly, drive cap assembly and piston. The spacer stack assembly can be removed easily without tools by using thumb and forefinger. Inspect the black o-rings and clear lip seals for wear or damage. Replace the entire stack if necessary. Do not disassemble the stack.

The spacer stack assembly may be chemically cleaned (dilute sodium bisulfite or vinegar) or wiped with a soft cloth.

The spacer stack assembly can be pushed in to the control valve body bore by hand. Since the spacer stack assembly can be compressed it is easier to use a blunt object (5/8" to 1-1/8" in diameter) to push the center of the assembly into the control valve body. The assembly is properly seated when at least four threads are exposed (approximately 5/8"). Do not force the spacer stack assembly in. The control valve body bore interior can be lubricated with silicone to allow for easy insertion of the entire stack. Do not use silicone or any other type of lubricant on the clear lip seals or the piston.

Reattach the drive cap assembly and the piston(s) and the drive assembly.

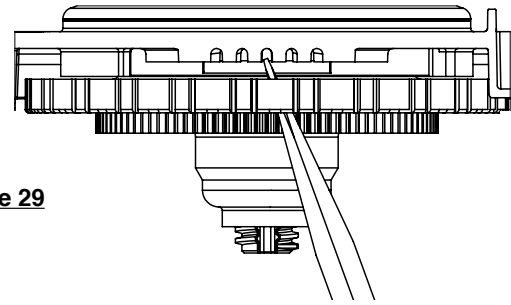

Figure 29

After completing any valve maintenance, press and hold NEXT and REGEN buttons for 3 seconds or unplug power source jack (black wire) and plug back in. This resets the electronics and establishes the service piston position. The display should flash all wording, then flash the software version and then reset the valve to the service position.

Injector Cap, Screen, Injector Plug and Injector Replacement

Unscrew the injector cap and lift off. Loosen cap with special plastic wrench or pliers if necessary. Attached to the injector cap is a screen. Remove the screen and clean if fouled.

Reattach the drive cap assembly and the piston(s) and the drive assembly.

After completing any valve maintenance, press and hold NEXT and REGEN buttons for 3 seconds or unplug power source jack (black wire) and plug back in. This resets the electronics and establishes the service piston position. The display should flash all wording, then flash the software version and then reset the valve to the service position.

Injector Cap, Screen, Injector Plug and Injector Replacement

Unscrew the injector cap and lift off. Loosen cap with special plastic wrench or pliers if necessary. Attached to the injector cap is a screen. Remove the screen and clean if fouled.

The plug and/or injector can be pried out with a small screwdriver. The plug can be wiped clean. If the plug leaks replace the entire plug. The injector consists of a throat and a nozzle. Chemically clean the injector with vinegar or sodium bisulfite. The holes can be blown out with air. Both pieces have smaller diameter holes that control the flow rates of water to insure that the proper concentration of regenerant is used. Sharp objects, which can score the plastic, should not be used to clean the injector. Scoring the injector or increasing the diameter of the hole could change the operating parameters of the injector.

Two holes are labeled DN and UP. Check for compliance. See Table Below.

COMPLIANCE TABLE

Application	Injector and/or Plug(s)	Main Piston	Regenerant Piston	Stack
H125 Downflow Softener or Regenerating Filter (1.32" Distributor)	Injector in "DN" hole, Plug in "UP" Hole	151-V3407	15-V3174	151-V3430
H125 Backwash Only Filter (1.32" Distributor)	Plug in "DN" and "UP" holes, Install Refill Port Plug	151-V3407	None	151-V3430

Push the plug(s) and/or injectors firmly in place, replace the screen and hand tighten the injector cap.

Refill Flow Control Assembly or Refill Port Plug

To clean or replace the refill flow control, pull out the elbow-locking clip and then pull straight up on the elbow. Replace the elbow locking clip in the slot so that it is not misplaced. Twist to remove the white flow control retainer. The flow control can be removed by prying upward through the side slots of the retainer with a small flat blade screwdriver.

Chemically clean the flow control or the white flow control retainer using dilute sodium bisulfite or vinegar. Do not use a wire brush. If necessary, replace the flow control, o-ring on the flow control retainer, or the o-ring on the elbow.

Reseat the flow control so the rounded end is visible in the flow control. Reseat the white flow control retainer by pushing the retainer into the elbow until the o-ring seats. Remove locking clip, push down on elbow to reseat and insert locking clip.

Do not use Vaseline, oils, or other unacceptable lubricants on o-rings. A silicone lubricant may be used on the o-ring on the elbow or the white retainer.

Water Meter or Meter Plug

The water meter assembly is connected to the PC board by a wire. If the entire water meter assembly is to be replaced, remove the control valve cover and disconnect the power source and water meter plugs from the PC board. Unlatch the drive assembly and lean it in forward. Unthread the water meter wire from the side of the drive assembly and through the drive back plate. To reinstall, rethread the water meter through the drive back plate and side of the drive assembly. Reattach the drive assembly and the water meter and power plugs.

If no water meter is visible, then a plug is installed, not a water meter.

The water meter wire does not need to be removed from the PC board if the water meter is only being inspected and cleaned. To remove the water meter assembly, unscrew the meter cap on the left side of the control valve. Pliers may be used to unscrew the nut if necessary.

With the nut removed, a slot at the top of the water meter is visible. Twist a flat blade screwdriver in the slot between the control valve body and the meter. When the meter is part way out it is easy to remove the water meter from the housing. Once the water meter is removed from the control valve body, gently pull forward on the turbine to remove it from the shaft.

Do not use a wire brush to clean the turbine. Wipe with a clean cloth or chemically clean in dilute sodium bisulfite or vinegar. The turbine can be immersed in the chemical.

Do not immerse electronics. If the turbine is scored or damaged or the bearings on the turbine are worn, replace the turbine.

Do not lubricate the turbine shaft. The turbine shaft bearings are prelubricated. Do not use Vaseline, oils, or other unacceptable lubricants on the o-ring. A silicone lubricant may be used on the black o-ring.

Snap the turbine on the shaft and reinsert the water meter into the side slot. Hand tighten the nut. Do not use a pipe wrench to tighten nut.

Bypass Valve

The working parts of the bypass valve are the rotor assemblies that are contained under the bypass valve caps. Before working on the rotors, make sure the system is depressurized. Turn the red arrow shaped handles towards the center of the bypass valve and back several times to ensure rotor is turning freely.

The nuts and caps are designed to be unscrewed or tightened by hand. If necessary a pliers can be used to unscrew the nut or cap. Do not use a pipe wrench to tighten or loosen nuts or caps. Do not place screwdriver in slots on caps and/or tap with a hammer. To access the rotor, unscrew the cap and lift the cap, rotor and handle out as one unit. Twisting the unit as you pull it out will help to remove it more easily. There are three o-rings: one under the rotor cap, one on the rotor stem and the rotor seal. Replace worn o-rings. Clean rotor. Reinstall rotor.

When installing the red arrow handles be sure that:

1. The handle pointers are lined up with the control valve body arrows, and the rotor seal o-ring and retainer on both rotors face to the right when being viewed from the front of the control valve; or
2. Arrows point toward each other in the bypass position.

Since the handles can be pulled off, they could be accidentally reinstalled 180° from their correct orientation. To install the red arrow handles correctly, keep the handles pointed in the same direction as the arrows engraved on the control valve body while tightening the bypass valve caps.

After completing any valve maintenance, press and hold NEXT and REGEN buttons for 3 seconds or unplug power source jack (black wire) and plug back in. This resets the electronics and establishes the service piston position. The display should flash all wording, then flash the software version and reset the valve to the service position.

Service Rates & Pressure Drop Charts

H125-32-10

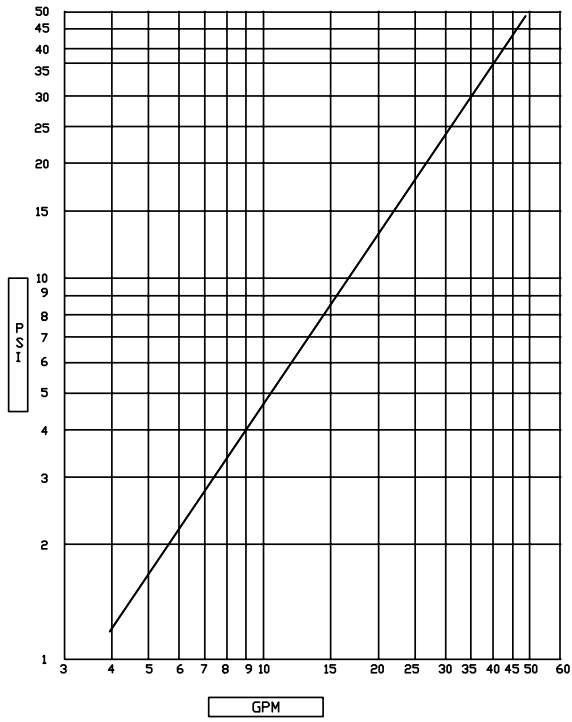

H125-48

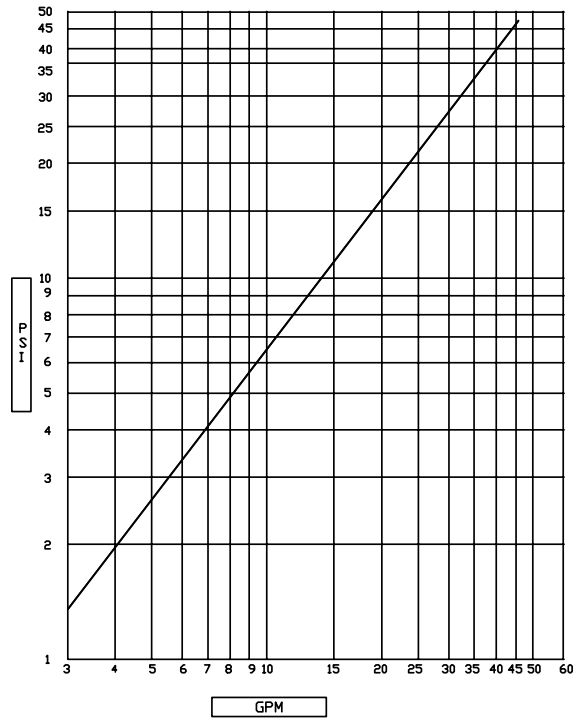

H125-64

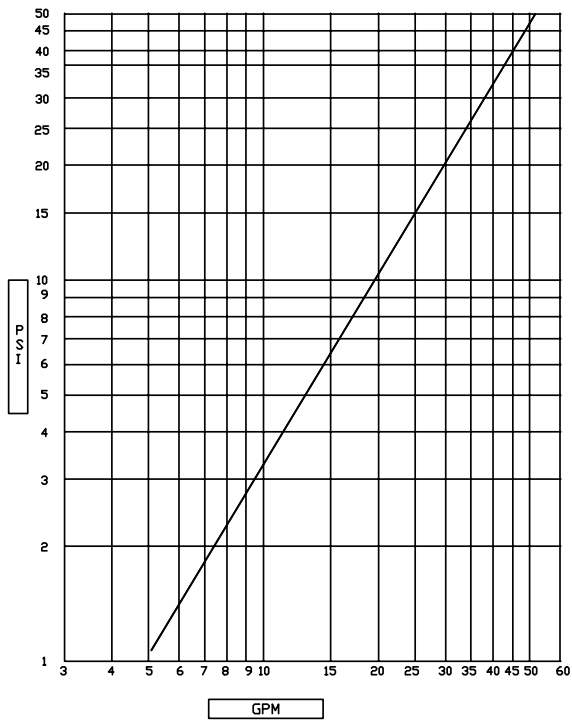

H125-96

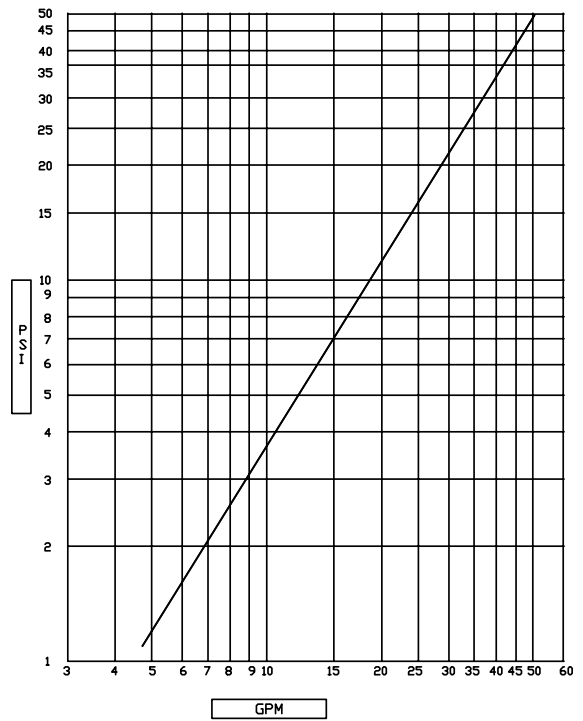

Service Rates & Pressure Drop Charts

H125-128

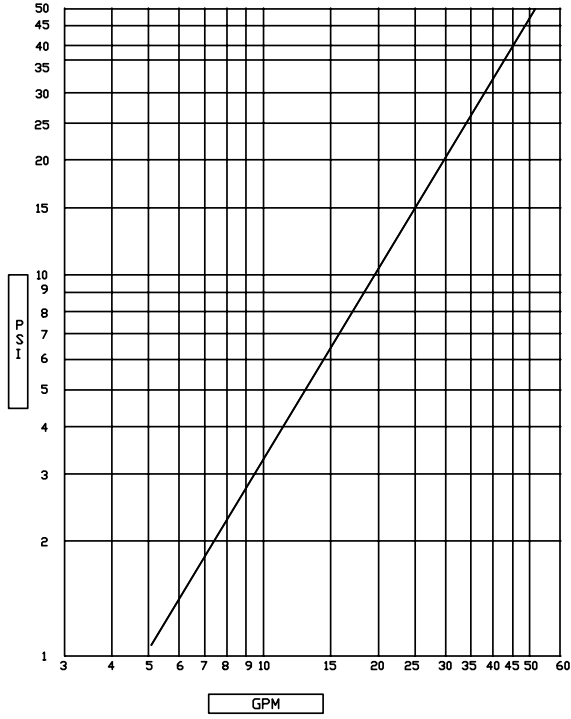

H125-160

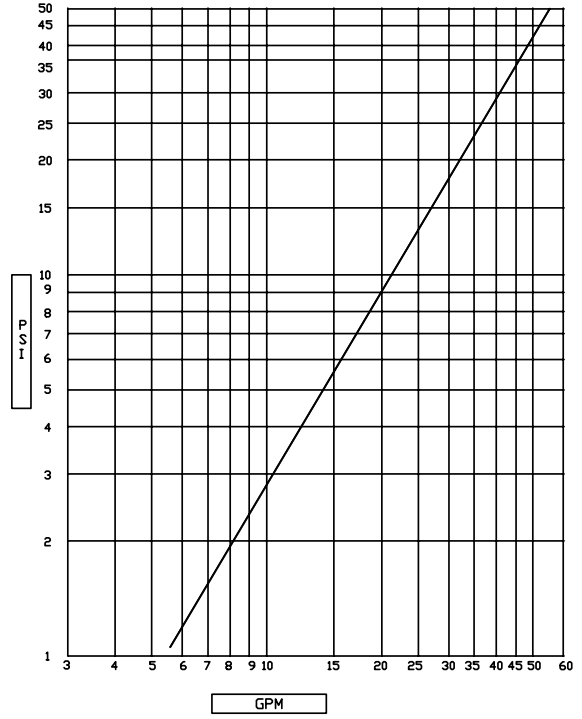

H125-192

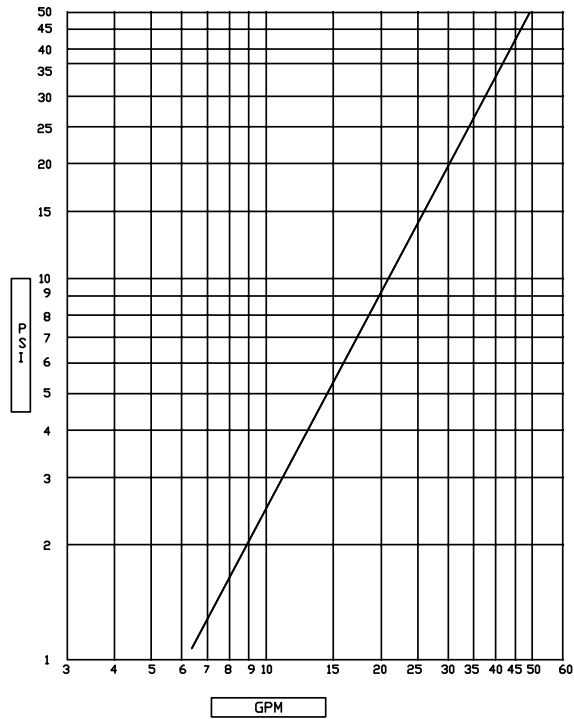

H125 SERIES WATER SOFTENERS LIMITED WARRANTY

Hellenbrand, Inc., warrants to the original consumer purchaser that the H125 Series and the parts listed below will be free from defects in material and/or workmanship from the date of the original installation for the following time periods:

For a Period of FIVE YEARS: The control valve including electrical parts, internal parts, and valve body.

For a Period of TEN YEARS: Mineral tanks, 6" Diameter - 13" Diameter.

For a Period of FIVE YEARS: Mineral tanks, 14" - Up.

For a Period of FIVE YEARS: The salt storage/cabinet tank.

For a Period of ONE YEAR: Any other component.

Any parts used for replacement are warranted for the remainder of the original warranty period applicable to the part.

THIS WARRANTY IS EFFECTIVE TO THE ORIGINAL CONSUMER PURCHASER ONLY, AND ONLY AS LONG AS THE H125 SERIES REMAINS AT THE ORIGINAL INSTALLATION SITE.

No sales representative, distributor, agent, dealer, reseller or any other person is authorized to make any other warranty on behalf of Hellenbrand, Inc. Upon expiration of the applicable warranty period(s), Hellenbrand, Inc., shall have no further liability related to the products/parts to which the warranty period(s) apply, except with respect to valid warranty claims asserted during the appropriate warranty period(s).

If a part described above becomes defective within the specified warranty period, you should notify your H125 Series sales representative and arrange a time during normal business hours for the inspection of the water conditioner at the original installation site. Any part found defective within the terms of this warranty will, at Hellenbrand, Inc.'s option, be repaired or replaced. You are responsible for freight from our factory and local service charges. This paragraph sets forth the exclusive remedy for any valid warranty claims against Hellenbrand, Inc.

THIS WARRANTY DOES NOT COVER defects caused by sand, sediment or bacteria fouling, accident, fire, flood, Act of God, misuse, misapplication, neglect, alteration, installation or operation contrary to Hellenbrand, Inc.'s printed instructions, or installation, repair or service by anyone other than Hellenbrand, Inc., or an authorized Hellenbrand reseller.

As a manufacturer, we do not know the characteristics of your water supply or the purpose for which you are purchasing this water conditioner. Please understand that the quality of water supplies may vary seasonally or over a period of time, and that your water usage rate may vary as well. Water characteristics can also change considerably if your water conditioner is moved to a new location. For these reasons, we assume no liability for the determination of the proper equipment necessary to meet your requirements and we do not authorize others to assume such obligations for us.

REMEDIES FOR DEFECTS OR FAILURES, TO THE EXTENT PERMITTED BY APPLICABLE LAW, ARE LIMITED TO THE REMEDIES PROVIDED IN THIS WARRANTY. ANY EXPRESS WARRANTY NOT PROVIDED HEREIN AND ANY WARRANTY WHICH MIGHT ARISE BY IMPLICATION OR OPERATION OF LAW, WHETHER FROM THE SELLER AND/OR MANUFACTURER OF THIS PRODUCT, IS HEREBY EXCLUDED AND DISCLAIMED, TO THE EXTENT ENFORCEABLE UNDER APPLICABLE LAW, INCLUDING WITHOUT LIMITATION IMPLIED WARRANTIES OF MERCHANTABILITY, FITNESS FOR ANY PARTICULAR PURPOSE OR NON-INFRINGEMENT, OR ANY WARRANTIES ARISING FROM COURSE OF PERFORMANCE, COURSE OF DEALING, OR FROM USAGES OF TRADE.

UNDER NO CIRCUMSTANCES SHALL HELLENBRAND, INC., BE LIABLE TO THE ORIGINAL CONSUMER PURCHASER OR TO ANY OTHER PERSON FOR ANY INCIDENTAL, SPECIAL OR CONSEQUENTIAL DAMAGES OR FOR ANY OTHER LOSS, DAMAGE, OR EXPENSE OF ANY KIND, INCLUDING LOSS OF PROFITS, WHETHER ARISING OUT OF BREACH OF WARRANTY, BREACH OF CONTRACT, IN TORT OR OTHERWISE, AND REGARDLESS OF WHETHER HELLENBRAND, INC., WAS AWARE OF THE POSSIBILITY OF SUCH LOSS. THESE LIMITATIONS WILL APPLY REGARDLESS OF ANY FAILURE OF ESSENTIAL PURPOSE OF ANY LIMITED REMEDY.

Some states do not allow limitations on how long an implied warranty lasts or exclusions or limitations of incidental or consequential damages, so the above limitations or exclusions may not apply to you. This warranty gives you specific legal rights, and you may also have other rights which vary from state to state.