

# PI-1000 Series

## Portable data terminal

### User's Manual

PI-1010/PI-1030/PI-1060/PI-1230



<http://www.argox.com>

[service@argox.com](mailto:service@argox.com)

V1.2 05-06-2018

## **Regulatory Compliance**

### **FEDERAL COMMUNICATIONS COMMISSION INTERFERENCE STATEMENT**

This equipment has been tested and found to comply with the limits for a Class B digital device, pursuant to part 15 of the FCC Rules. These limits are designed to provide reasonable protection against harmful interference in a residential installation. This equipment generates, uses and can radiate radio frequency energy and, if not installed and used in accordance with the instructions, may cause harmful interference to radio communications. However, there is no guarantee that interference will not occur in a particular installation. If this equipment does cause harmful interference to radio or television reception, which can be determined by turning the equipment off and on, the user is encouraged to try to correct the interference by one or more of the following measures:

- Reorient or relocate the receiving antenna.
- Increase the separation between the equipment and receiver.
- Connect the equipment into an outlet on a circuit different from that to which the receiver is connected.
- Consult the dealer or an experienced radio/ TV technician for help.

**CAUTION:**

Any changes or modifications not expressly approved by the grantee of this device could void the user's authority to operate the equipment.

PI-1010 EN 300 328 BT RF Power EIRP 1.92 dbm

PI-1060 EN 300 328 BT RF Power EIRP 1.92 dbm

PI-1060 EN 300 200 SUB-1G RF Power EIRP 5.17 dbm

PI-1030 EN 300 328 BT RF Power EIRP 1.92 dbm

PI-1030 EN 300 328 WIFI RF Power EIRP 19.04 dbm

PI-1230 EN 300 328 BT RF Power EIRP 1.92 dbm

PI-1230 EN 300 328 WIFI RF Power EIRP 19.04 dbm

**RF exposure warning**

**The equipment complies with FCC RF exposure limits set forth for an uncontrolled environment.**

**The equipment must not be co-located or operating in conjunction with any other antenna or transmitter.**

## Radio Transmitters (Part 15)

This device complies with Part 15 of the FCC Rules. Operation is subject to the following two conditions: (1) this device may not cause harmful interference, and (2) this device must accept any interference received including interference that may cause undesired operation.

FCC ID:NBF-PI-1X30 For PI-1010 & PI-1030 & PI-1230

FCC ID:NBF-PI-1X60 For PI-1060

Note:PI-1060 Only BT & Sub-1G RF Function



**CAUTION** This device emits CDRH/IEC Class 2 laser and IEC Class 1M light. Do not stare into beam.

### CAUTION: EXPLOSION HAZARD

Do not disassemble, short circuit, heat the battery or dispose of in fire. Store battery pack in a proper place. Do not expose to temperature above 60°C/140°F. Use specified charger only. Please dispose of the used batteries following the rules or laws issued by the local government.

警告：電池若未妥善處理，可能會導致爆炸。

請勿拆卸電池，或用火銷毀電池。請將電池放置於兒童拿不到的地方。  
請使用專用充電器充電，並請依照當地政府或法律規定妥善處理廢棄電池。

## 低功率電波無線輻射電機管理辦法

第十二條：經型式認證合格之低功率射頻電機，非經許可，公司、商號或使用者均不得擅自變更頻率、加大功率或變更原設計之特性及功能。

第十四條：低功率射頻電機之使用不得影響飛航影響安全及干擾合法通信，經發現有干擾現象時，應立即停用，並改善至無干擾時方得繼續使用。

前項合法通信，指一電信法規定作業之無線電通信。低功率射頻電機需忍受合法通信或工業、科學及醫療用電波輻射性電機設備之干擾。

本產品支援 WIFI/Bluetooth/Sub-1G(依不同型號有所不同)  
製造商：立象科技股份有限公司  
地址：新北市新店區寶橋路 235 巷 126 號 7 樓  
電話：02-8912-1121（代表號）

設備名稱：資料採集器，型號（型式）：PI-1010,PI-1030,PI-1230,PI-1060 Equipment name <sup>o</sup> Type designation (Type) <sup>o</sup>						
單元 Unit <sup>o</sup>	限用物質及其化學符號 <sup>o</sup>					
	鉛 Lead <sup>o</sup> (Pb) <sup>o</sup>	汞 Mercury <sup>o</sup> (Hg) <sup>o</sup>	鎘 Cadmium <sup>o</sup> (Cd) <sup>o</sup>	六價鉻 Hexavalent chromium <sup>o</sup> (Cr <sup>6+</sup> ) <sup>o</sup>	多溴聯苯 Polybrominated biphenyls <sup>o</sup> (PBB) <sup>o</sup>	多溴二苯醚 Polybrominated diphenyl ethers (PBDE) <sup>o</sup>
印刷電路板組件 <sup>o</sup>	○ <sup>o</sup>	○ <sup>o</sup>	○ <sup>o</sup>	○ <sup>o</sup>	○ <sup>o</sup>	○ <sup>o</sup>
螢幕 <sup>o</sup>	○ <sup>o</sup>	○ <sup>o</sup>	○ <sup>o</sup>	○ <sup>o</sup>	○ <sup>o</sup>	○ <sup>o</sup>
掃描模組 <sup>o</sup>	○ <sup>o</sup>	○ <sup>o</sup>	○ <sup>o</sup>	○ <sup>o</sup>	○ <sup>o</sup>	○ <sup>o</sup>
機殼 <sup>o</sup>	○ <sup>o</sup>	○ <sup>o</sup>	○ <sup>o</sup>	○ <sup>o</sup>	○ <sup>o</sup>	○ <sup>o</sup>
線材 <sup>o</sup>	○ <sup>o</sup>	○ <sup>o</sup>	○ <sup>o</sup>	○ <sup>o</sup>	○ <sup>o</sup>	○ <sup>o</sup>
變壓器 <sup>o</sup>	- <sup>o</sup>	○ <sup>o</sup>	○ <sup>o</sup>	○ <sup>o</sup>	○ <sup>o</sup>	○ <sup>o</sup>

備考1. “超出0.1 wt %”及“超出0.01 wt %”係指限用物質之百分比含量超出百分比含量基準值。  
Note 1: “Exceeding 0.1 wt %” and “exceeding 0.01 wt %” indicate that the percentage content of the restricted substance exceeds the reference percentage value of presence condition.<sup>o</sup>

備考2. “○”係指該項限用物質之百分比含量未超出百分比含量基準值。  
Note 2: “○” indicates that the percentage content of the restricted substance does not exceed the percentage of reference value of presence.<sup>o</sup>

備考3. “-”係指該項限用物質為排除項目。  
Note 3: The “-” indicates that the restricted substance corresponds to the exemption.<sup>o</sup>

# Release Note

---

<b>Version</b>	<b>Date</b>	<b>Note</b>
V1.0	02/22 2017	Initial release
V1.1	07/12 2017	Add Appendix A for reference
V1.1	02/13 2018	Add Appendix B for reference
V1.2	06/05 2018	Add PI-1060, Tag-60 information

# Content

1	Introduction.....	1
1.1	Unpacking .....	2
1.2	Understand your terminal .....	4
1.2.1	Terminal .....	4
1.2.2	Holder(Optional).....	5
1.3	Indicators .....	6
1.3.1	LED .....	6
1.3.2	Buzzer.....	8
1.3.3	Vibration .....	8
1.4	Keypad .....	9
1.5	Power source .....	15
1.6	Tag-60 introduction (PI-1060 only).....	16
2	Get started.....	17
2.1	Set up your terminal .....	21
2.2	User interface .....	23
2.3	Connection .....	25
2.3.1	Remote link connection .....	26
2.4	Attach the hand strap .....	30
2.5	Tag-60 (PI-1060).....	32
3	Controls and settings.....	35
3.1	User Menu .....	35
3.1.1	Run Program .....	36
3.1.2	Remote Link .....	36
3.1.3	Scanner(HID).....	37



3.1.4	Information .....	38
3.2	System Menu .....	39
3.2.1	Remote Link .....	39
3.2.2	Disk info .....	39
3.2.3	Timer setting.....	40
3.2.4	Environment .....	41
3.2.5	Test.....	42
3.2.6	System info.....	44
3.3	Supervisor Menu .....	45
3.3.1	Remote Link .....	46
3.3.2	Format disk .....	49
3.3.3	Setting.....	50
3.3.4	Information .....	55
4	Applications .....	56
5	Troubleshooting.....	57
5.1	Hardware issues.....	57
5.2	Communication issues.....	58
5.3	Barcode scanning issues .....	59
6	Specifications.....	60
	Appendix A .....	66
	Appendix B .....	83

# 1 Introduction

PI series is a lightweight, portable data terminal (PDT) for data capture and collection. This manual will help you to get to know PI series and utilize it well.

## Features

- **Scratch-resistant keypad** Coated with PC (polycarbonate), the letters and numbers on the keys won't wear off between uses.
- **Battery cover open detection** When the switch of the battery cover is up, the system automatically saves your files and shut down.
- **Large flash memory** PI series offers more flash memory than the rivals on the same level. The standard is 20 MB, and the optional is 60 MB.
- **Backup battery** The backup battery gives you additional 15 minutes to finish your job if the primary batteries wear out.
- **Wi-Fi connectivity** You can exchange data over a Wi-Fi network.(PI-1030)
- **Tag-60**

## 1.1 Unpacking

Make sure all of the following items are included in your package.

**PI series**

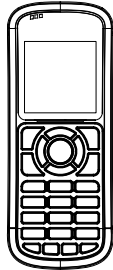

**Quick Start Guide**

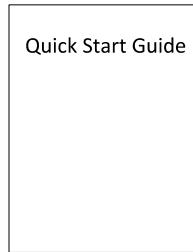

**USB Cable**

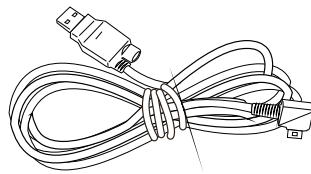

**or RS-232 Cable with USB power cord**

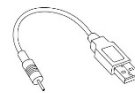
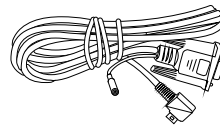

**Holder**

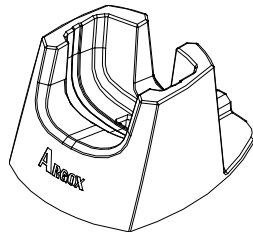

**Hand Strap**

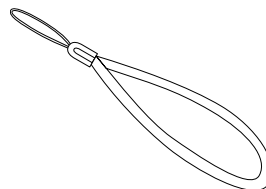

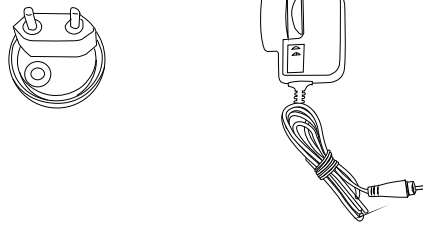
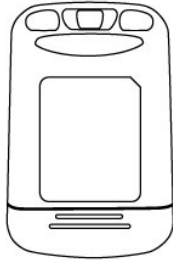
**Plug and Power Supply (Option)****Tag-60 (PI-1060)**

When you receive your terminal, open the package immediately and inspect for shipping damage. If you discover any damage, contact the shipping company and file a claim. Argox is not responsible for any damage incurred during shipping. Save all package materials for the shipping company to inspect.



---

**Note** If any item is missing, please contact your local dealer.

---

## 1.2 Understand your terminal

### 1.2.1 Terminal

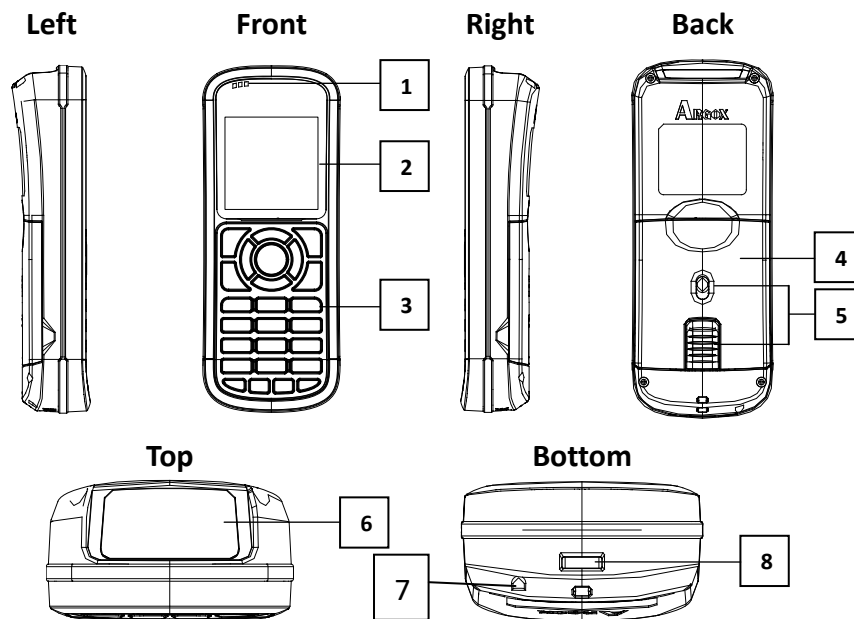

1	LED	Three LEDs.
2	LCD Display	A mono LCD.
3	Keypad	A 25-key keypad.
4	Battery Cover	The battery cover.
5	Battery Cover Switch	Open and close the battery cover.
6	Reading Window	The bar code reading beam is emitted through this window.
7	Speaker	Buzzer sound

## 1.2.2 Holder

The holder is used to hold your terminal in its standing position.

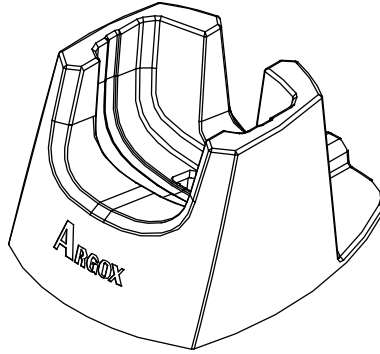

In the bottom of holder, make sure cable wire is installed as below.

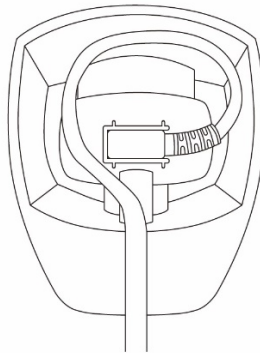

## 1.3 Indicators

PI series has three LEDs and a buzzer to indicate its current status.

### 1.3.1 LED

Your terminal has three LEDs on the upper-left corner. They have different behavior. The table below gives information about the status they indicate.

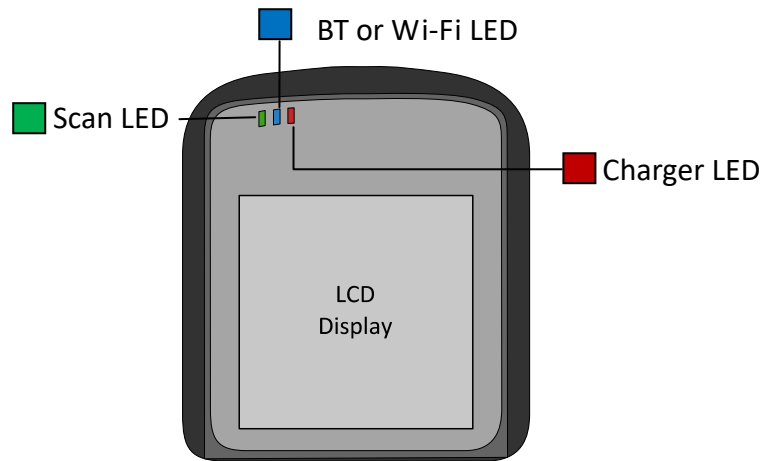

LED	Color
Scan LED	Green, Red and Orange
BT or Wi-Fi LED	Blue
Charger LED	Red

<b>LED</b>	<b>Behavior</b>	<b>Status</b>	<b>Note</b>
<b>Scan</b>	Solid green	User defined	Use SDK.
<b>LED</b>	Solid red	User defined.	Use SDK.
	Solid orange	User defined.	Use SDK.
	Flashing green	Transmitting data or user defined.	Use SDK.
	Flashing red	User defined.	Use SDK.
	Flashing orange	User defined.	Use SDK.
	Off	No data transmission or user defined.	Use SDK.
<b>BT &amp; Wi-Fi LED</b>	Solid blue	Your terminal is connected through Bluetooth or Wi-Fi.	
	Flashing blue	Your terminal is ready to be connected through Bluetooth or Wi-Fi.	
	Off	Bluetooth or Wi-Fi is turned off.	Default
<b>Charger LED</b>	Solid red	Your terminal is fully charged or connected to a power source.	Controlled by hardware.
	Flashing red	Charging.	Controlled by



LED	Behavior	Status	Note
	Off	Your terminal is not connected to any power source.	hardware. Controlled by hardware.

## 1.3.2 Buzzer

You can define the status the vibration indicates using the SDK.

Sound	Status
<b>1 Short Beep</b>	A key is pressed.
	A good scan.
	An error occurred.
<b>2 Short Beep</b>	The battery is low.
<b>4 Short Beep</b>	Battery is too low to turn off terminal.

## 1.3.3 Vibration

You can define the status the vibration indicates using the SDK.

Vibration	Status
<b>Vibrate</b>	A good scan.

## 1.4 Keypad

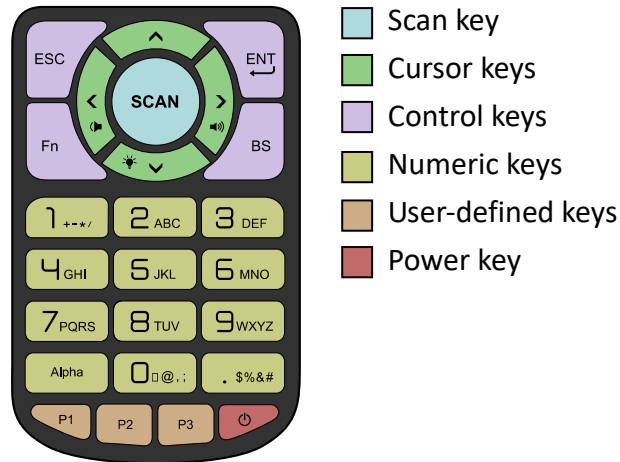

### Scan key

Scan a bar code.

### Cursor keys

<b>Up</b>	Move the highlight bar up.
<b>Fn+Up</b>	Open Message Menu.
<b>Down</b>	Move the highlight bar down.
<b>Fn+Down</b>	Adjust the backlight brightness. The brightness repeats the sequence 0→1→2→3.
<b>Left</b>	Move the highlight bar to the top.
<b>Fn+Left</b>	Reduce the volume.
<b>Right</b>	Move the highlight bar to the bottom

### Cursor keys

**Fn+Right** Increase the volume.

### Control keys

<b>ESC</b>	The Escape key.	<ol style="list-style-type: none"> <li>1. Go up one level in a menu.</li> <li>2. Give up changing a setting.</li> <li>3. Exit a program.</li> </ol>
------------	-----------------	---

<b>Fn</b>	The Function key.	Use with other keys. Ex: "Fn+Down Arrow" is to adjust the backlight brightness. The function of F0 - F9 (Fn+0 - 9) can be defined using an SDK.
-----------	-------------------	---

<b>ENT</b>	The Enter key.	<ol style="list-style-type: none"> <li>1. Enter a menu.</li> <li>2. Select an option.</li> </ol>
------------	----------------	--

<b>BS</b>	The Backspace key.	<ol style="list-style-type: none"> <li>1. Delete a character to the left of the cursor.</li> </ol>
-----------	--------------------	--

### Numeric keys

**You can use the keypad to enter numbers or English characters, depending on the mode you're using.**

<b>1</b>	<ol style="list-style-type: none"> <li>1. Enter the number one.</li> <li>2. Enter these signs: plus (+), minus (-), star (*) and slash (/).</li> </ol>
----------	--

<b>2</b>	<ol style="list-style-type: none"> <li>1. Enter the number two.</li> <li>2. Enter the letters A, B, C.</li> </ol>
----------	---

**Numeric keys**

- |              |  |
|--------------|--|
| <b>3</b>     | 1. Enter the number three.<br>2. Enter the letters D, E, F.  |
| <b>4</b>     | 1. Enter the number four.<br>2. Enter the letters G, H, I.   |
| <b>5</b>     | 1. Enter the number five.<br>2. Enter the letters J, K, L.   |
| <b>6</b>     | 1. Enter the number six.<br>2. Enter the letters M, N, O.  |
| <b>7</b>     | 1. Enter the number seven.<br>2. Enter the letters P, Q, R, S.   |
| <b>8</b>     | 1. Enter the number eight.<br>2. Enter the letters T, U, V.  |
| <b>9</b>     | 1. Enter the number nine.<br>2. Enter the letters W, X, Y, Z.  |
| <b>0</b>     | 1. Enter the number zero.<br>2. Enter these characters: space ( ), at (@),<br>comma (,) and semicolon (;).                     |
| <b>Alpha</b> | Switch the input method between numbers,<br>uppercase and lowercase characters.  |
| <b>.</b>     | 1. Enter a period (.).<br>2. Enter these symbols: dollar sign (\$),<br>percent sign (%), ampersand (&) and<br>number sign (#). |

**User-defined keys**

<b>P1</b>	User-defined key.
<b>P2</b>	User-defined key.
<b>P3</b>	User-defined key.

**Power key**

Turn on or turn off your terminal.

**Power combination key**

You can use the key combinations to enter different menus or modes. Press and hold the combination of keys, until your terminal responds.

<b>3 + 9 + Power</b>	System Menu.
<b>1 + 3 + 0 + Power</b>	Supervisor Menu.
<b>1 + 3 + Power</b>	Force mode.
<b>P1 + P2 + P3 + Power</b>	BIOS reset.
<b>SCAN + Power</b>	Warm reset.
<b>SCAN + Power (5 sec)</b>	Cold reset. You need to press the keys for 5 seconds.

- **System Menu** Enter System Menu.
- **Supervisor Menu** Enter Supervisor Menu.
- **Force mode** It updates all firmware files and restores all system parameters to factory settings. This mode needs to be used with an SDK or computer software. You can use this mode when you encounter the problem that can't be resolved in any other way.
- **BIOS reset** it is the same as **BIOS default** (see Supervisor Menu). It resets all your terminal settings, including the password of Supervisor Menu.
- **Warm reset** It restarts your terminal without changing any settings. You can use it when your program stops responding.
- **Cold reset** It forces your terminal to restart. The data stored in the DRAM may be removed. You can use it when your terminal crashes, or when you can't turn on your terminal by pressing the Power key.



## 1.5 Power source

There are three ways to supply power to PI series:

1. Two AA batteries. Recommended alkaline rechargeable type.
2. Use the USB cable with computer.
3. Use the power supply with the USB or RS-232 cable.

Cable Type	Charge your batteries	Supply power without batteries	Need to use with a power supply
USB	Yes	Yes	No
RS-232	No	No	Yes



---

**Note** It's not necessary to use a USB cable with the power supply, but the battery charging time is shorter with it.

---



## 1.6 Tag-60 introduction (PI-1060 only)

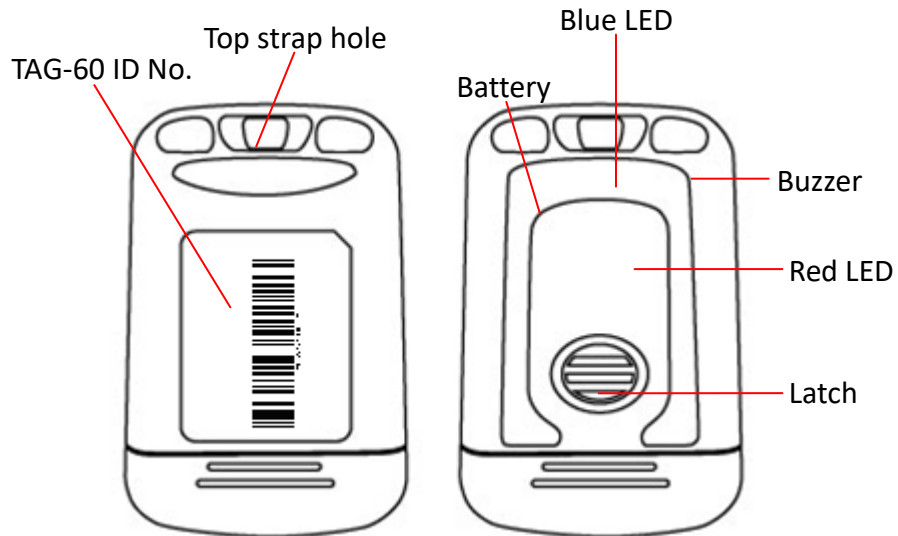

You can define indicator function by using SDK or Skywalker.

LED Color	Status
Blue	Tag-60 is called.
Red	Tag-60 battery low warning

Sound	Status
Beep	Beep is defined by PI-1060 application.

## 2 Get started

This chapter provides information about how to work with your terminal and make connection to computer.

### Inserting or replacing battery

When you see the battery icon shows low. You need to change new battery or charge it immediately. If there is no power, the back up battery can hold the data about 15 minutes. Therefore, always upload your important data after work or keep two AA batteries in case.



**Caution** Do not mix old batteries and new batteries or standard (carbon-zinc) with alkaline batteries. Remove batteries if product is not to be used with for a long time. Risk of explosion if battery is replaced by an incorrect type. Dispose of used batteries according to the instructions.

**DO NOT RECHARGE DIFFERENT TYPES OF BATTERIES.**

1. Press and slide two release latches at the same time to open the battery cover.

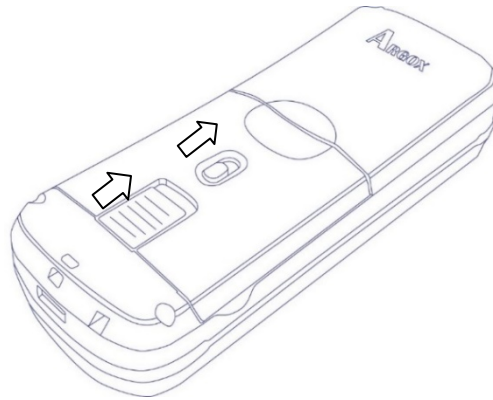

2. Inserting two batteries as indicated inside battery compartment.

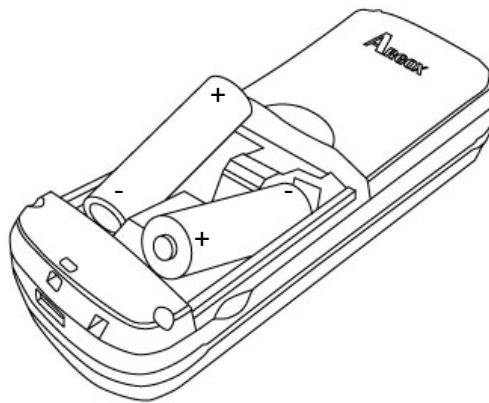

3. Close the battery cover as follow.

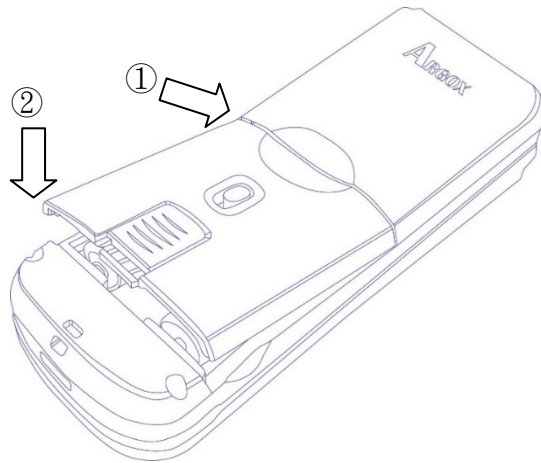

4. Make sure cover is closed and slide two latches back.

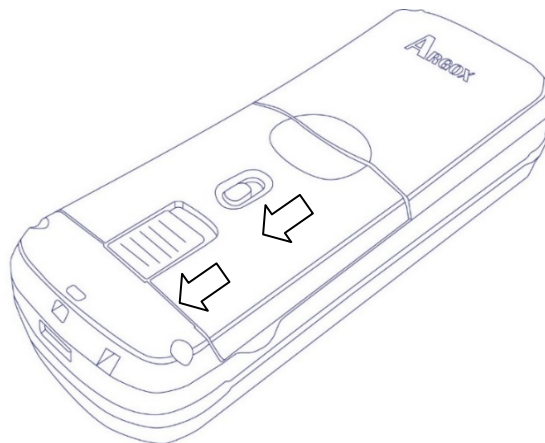

## Charge the battery

If you're using rechargeable batteries to supply power to your terminal, you can charge them by

- (1) connecting the USB cable to your terminal and computer.
- (2) Using a battery charger to charge batteries in advance.
- (3) Connecting the USB cable to your terminal and use a power supply.

When your batteries are fully charged, the Charger LED turns to solid red.

Charging by	Full Charge Time
Power Supply	5-6 hours
USB Cable	7-8 hours

**Important** Before using PI series, we



recommend to charge PI-1000 series 1 day to make sure backup battery is fully charged.



**Important** To protect power source, PI series can not be powered on unless battery cover back are closed correctly.



---

**Note** The triangle mark should be face up when you want to connect to PI series.

---

## 2.1 Set up your terminal

1. Choose one to power on your terminal
  - Open the battery cover and Install two AA

batteries.

- Connect your terminal to your computer using USB or RS-232 cable.

2. Press the Power key to turn on your terminal.

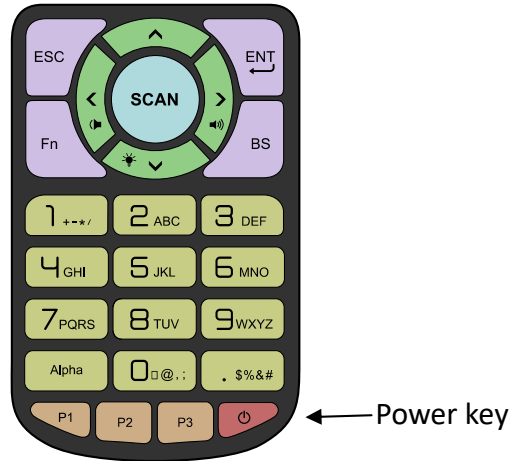

## 2.2 User interface

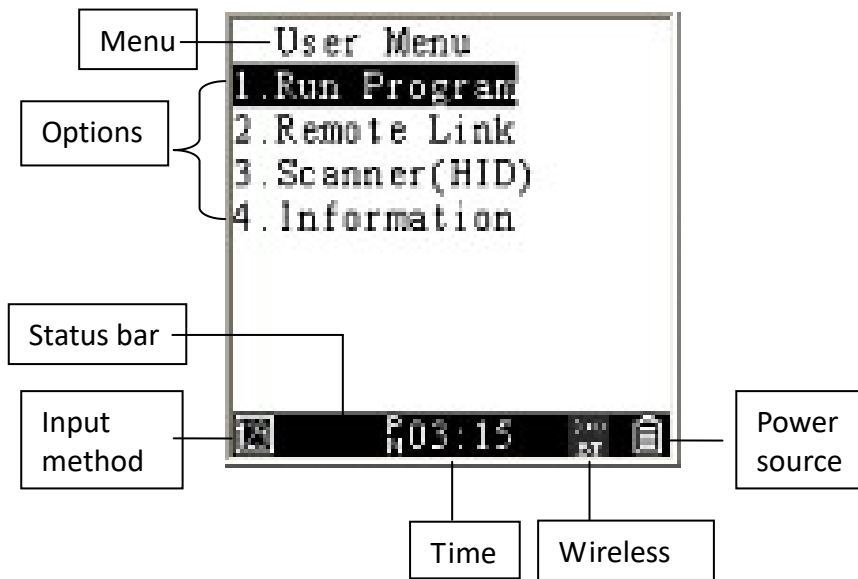

Item	Description
<b>Menu</b>	Current menu title
<b>Options</b>	Items in the menu.
<b>Status bar</b>	It displays the information about your terminal.
<b>Input method</b>	The way you enter data. You can enter numbers, lowercase or uppercase characters.
<b>Time</b>	The current time.



<b>Item</b>	<b>Description</b>
<b>Wireless communication</b>	When you open Bluetooth or Wi-Fi function, it displays an icon without waves. If connection is successful, the icon will show waves.
<b>Power source</b>	If your terminal is connected to a direct power supply (USB or RS-232), it displays a plug icon; if it is running on batteries, it displays a battery icon.

## 2.3 Connection

PI series have four interfaces to connect: **USB, RS232, Bluetooth** and **WI-FI**. Each one can choose two ways as below.

**Remote link:** It is a unique protocol from Argox development. Visit Argox website below to download application.

<http://www.argox.com/content2011.php?sno=0000033>

**Linking port:** Developer can set up different interfaces USB/WIFI/COM/BT according to their application.



**Important** **Remote link** has to use Argox application, such as PhoenixVoler or Everlink from Argox.

---

## 2.3.1 Remote link connection

This section will show how to link PI series to PC with “Remote link” and enter “Message menu” to send message when the connection successful.

---

*Use Remote link to connect PC with USB*

---

**Step 1.** After link USB cable between PI series and PC, press “Power” key to power on PI series.

**Step 2.** Move curse to “Remote Link” and press “ENT” key.



**Step 3.** Enter “Remote I/F Select” and Choose “USB”.  
It will get return last page when press”Enter”

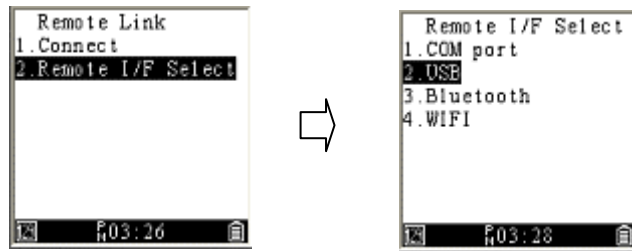

**Step 4.** Choose “Connect”.

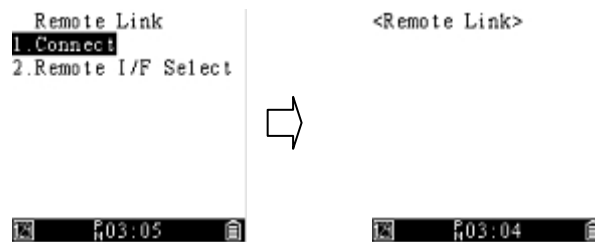

**Step 5.** In PhoenixVoler or Everlink, Click Comm setup  
will show the model number. Successfully  
connected to PC.

---

### Message Menu

---

Everlink, ControlCenter and PI series can send message to PI series. Press “Fn”+“^” key to enter



Message Menu.

- **Read priority Msg.:** It shows the priority message you receive.
- **Read Msg.:** It shows the message you sent.
- **Send Msg.:**
  - ✧ To Everlink: “Send to” is 9000
  - ✧ To ControlCenter: “Send to” is 9001
  - ✧ To otherPI series device: “Send to” default depends on SN last four digits. To change ID, refer to “[Equipment ID](#)” in System menu.



**Important** Sending message rely on Everlink. PI

series must connect to Everlink then the message will start to send and receive.

---

## 2.4 Attach the hand strap

Sometimes you may need to do something and can't hold your terminal on your hand. Or, you might accidentally drop your terminal between uses. Attach the hand strap is a useful way to resolve these issues. You can wrap the strap around your hand to secure it to your hand, or hang it on your hand to have both hands free to do other things.

To attach the hand strap, do this:

1. Pinch the small loop and thread it into the two square holes under the battery cover.

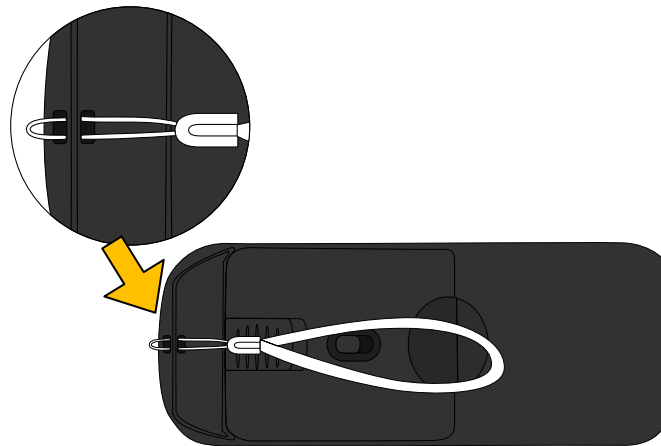

2. Thread the big loop into the small loop, and pull the big loop to tie a knot.

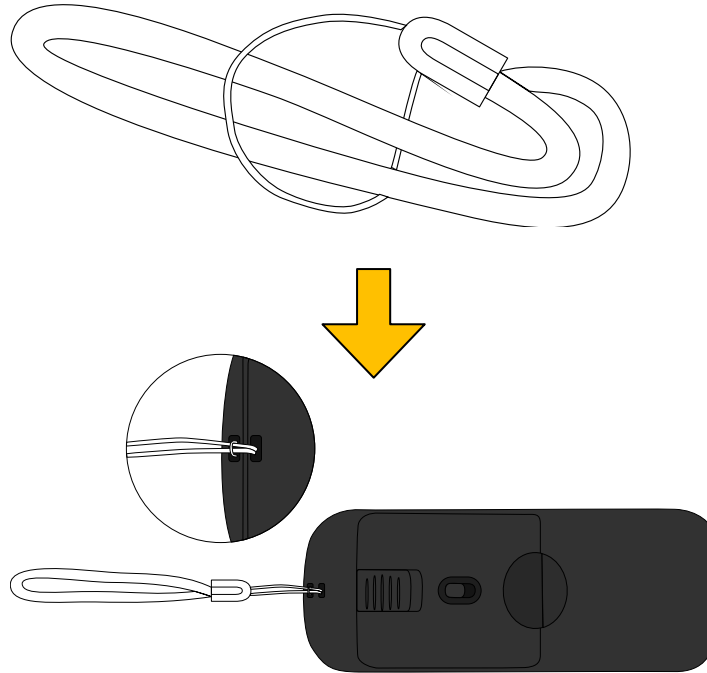

---

**Important** Use hand strap when you collect barcode in case drop accident. PI series might shut down to protect data after drop.

---



## 2.5 Tag-60 (PI-1060)

### Start Tag-60 up

1. Hold Tag-60 bottom, press latch to remove cover.

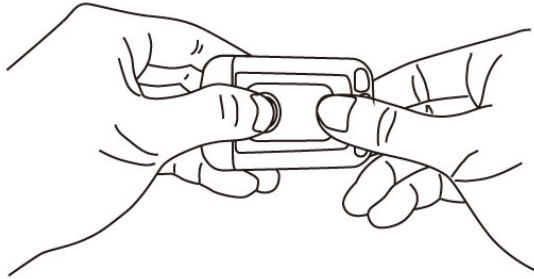

2. Remove battery insulation to start Tag-60 up.

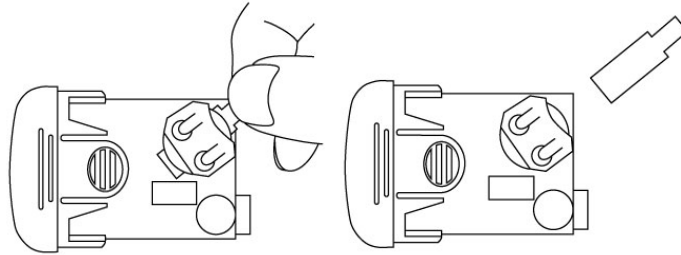

3. Make sure battery is in the slot and close cover back.

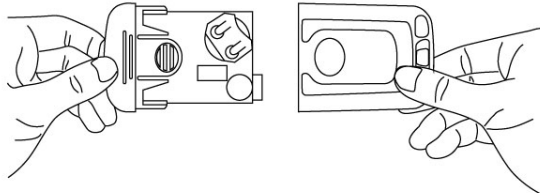

## Insert or replacing Battery

1. Hold Tag-60 bottom cover, press latch to remove cover.

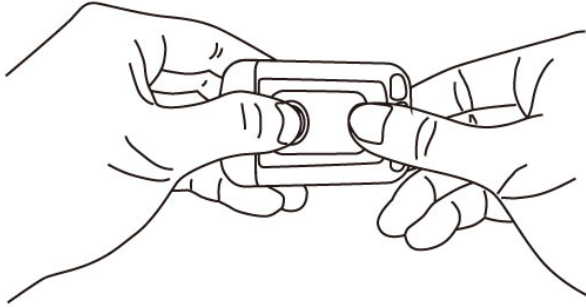

2. Replace CR-2032 coin battery. Make sure positive electrode is up.

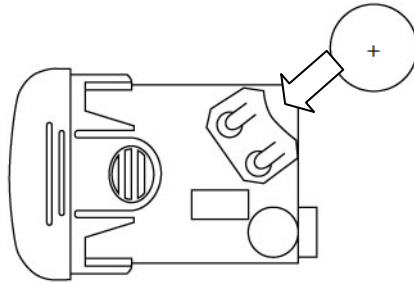

3. Make sure battery is in the slot and close cover back.

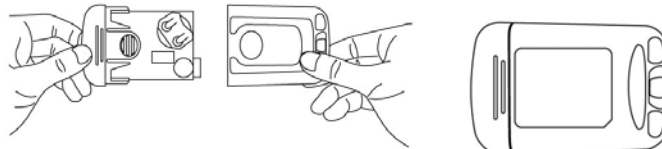

## Top Strap hole

Top case is designed 3 holes for placing Tag-60 easily. Attach a strap on Tag-60 can hanging it everywhere and also prevent drop damage.



## 3 Controls and settings

PI series offers three different layer menus. **User Menu** is for general users, **System Menu** is for supervisors or managers, and **Supervisor Menu** is for system administrators or engineers. Besides, press Fn+^ can enter **Message Menu** This chapter provides information about these menus.

### 3.1 User Menu



User Menu includes three frequently used settings. You can use them to run your program, connect your terminal to a computer or other device, or display your terminal's information (via Everlink).

### 3.1.1 Run Program

It shows the program you download from your computer. To run a program, just select it and press **ENT**. If there's no program, it will tell you "No program file."  
For more information about how to connect to a computer and download programs from it, see PhoenixVoler or Everlink User guide.



---

**Note** Default setting between PI Series and Program is individual

---

### 3.1.2 Remote Link

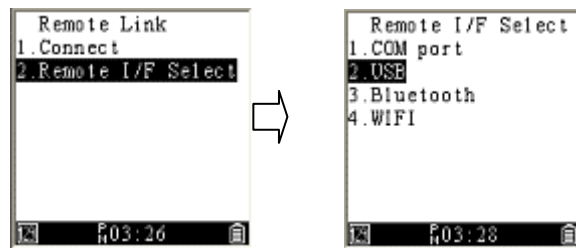

It is for you to connect your terminal with Everlink or

PhoenixVoler to computer.

- **Connect** It connects your terminal to computer after you select an interface.
- **Remote I/F Select** It provides interfaces, including **COM port, USB, Bluetooth and WI-FI.**

To connect your terminal, do this:

1. Select **Remote Link > Remote I/F Select > COM port/USB/Bluetooth/WI-FI.**
2. Go up one level in the menu and select **Connect.**



---

**Note** If you want to connect via Bluetooth or WI-FI, you need to enter Supervisor Menu and set up Bluetooth connection or WI-FI connection first. After completing the setting, you can connect your terminal from User Menu **Connect.**

---

### 3.1.3 Scanner(HID)

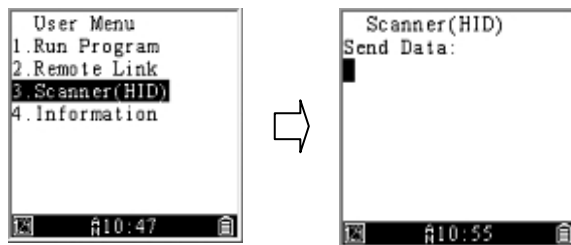

It is for you to read and upload barcode data easily.  
Once you have connection to computer. Press “SCAN”  
key to read barcode and it will upload data. Go to CH 4  
[Application](#). see more in Everlink user guide.



**Note** Make sure you turn on the decode  
function([barcode default](#)).

### 3.1.4 Information



It displays your terminal's information.

<b>IPL</b>	The IPL version.
<b>BOOT</b>	The boot version.
<b>Kernal</b>	The kernel version.
<b>Scanner</b>	The scanner's firmware version.
<b>SN</b>	The serial number.
<b>DefLang</b>	The display language.

## 3.2 System Menu

Under System Menu, you can change system settings to meet your need and run some tests to see if your terminal is working properly. Press key 3 + 9 + Power to enter system menu.

### 3.2.1 Remote Link

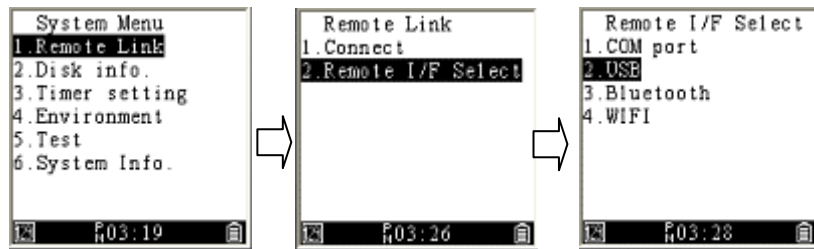

See the description in [Remote Link](#) in User Menu.

### 3.2.2 Disk info





It provides the disk information, including the free, used and total disk space. By default, your terminal has two disks: C and D.

- C RAM For data memory
- D Flash For system and user's application

### 3.2.3 Timer setting

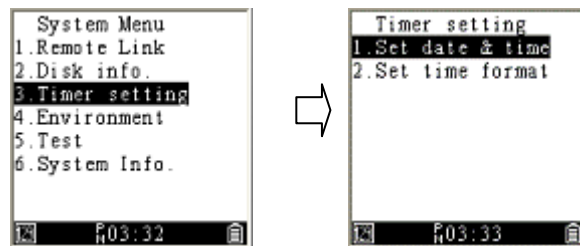

- **Set date & time** You can set date and time here.
- **Set time format** You can set the time format here. It provides the 12-hour or 24-hour clock and only display in Status Bar.

## 3.2.4 Environment

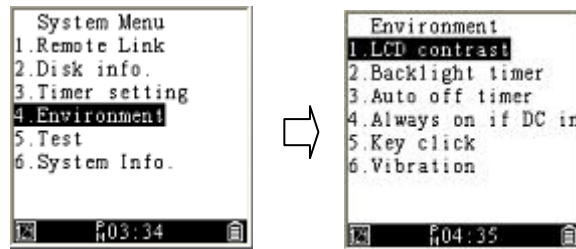

It provides settings for you to adjust different workplace or match your preference.

- **LCD contrast** It determines the contrast ratio. The bigger the number, the lower the contrast (the darker the screen).1~10
- **Backlight timer** It determines how long the backlight stays on after you press a key.1~65535. Set 0 will always on.
- **Auto off timer** It turns off your terminal after a certain amount of time elapsed. The unit of time is the second. If you set it 0, your terminal is always turned on.30~65535
- **Always on if DC in** It will always on when you plug DC power. Default is disable.

- **Key click** You can turn on or turn off the sound of keypad.
- **Vibration** It determines how long your terminal vibrates. The unit is 0.1 second, range is 1~255. Set 0 will turn it off.

### 3.2.5 Test

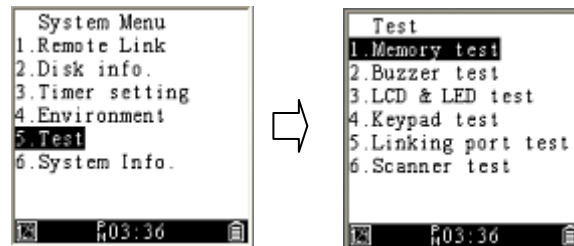

It provides various tests for you to check your terminal system.

- **Memory test** It checks if the memory can be written and read properly. Note that this test removes all data stored in the memory, so remember to save your files in advance.
- **Buzzer test** It checks if the buzzer can make sound properly. You'll hear the sound repeatedly plays from

high to low and from low to high. If the sound is played smoothly, it means the buzzer works properly, otherwise the buzzer may have some issues.

- **LCD & LED test** It checks if the LCD display has bad pixels.
- **Keypad test** It checks if the keypad works properly when you press it.
- **Linking port test** It checks if the port works properly. You need to set a port to run this test. For more information about the port setting, see the description in [Setting](#) in Supervisor Menu.

After you set a port, do this:

1. Select the port you want to test, and press **ENT**.
  2. Your terminal will show if the test is successful or failed after the test is complete.
- **Scanner test** It checks if your terminal can read bar codes when you press **SCAN** to scan bar codes. If the scan is successful, your terminal will vibrate and display the bar code data.



---

**Note** When you do scanner test to barcode, turn on the function in **Barcode config** (Supervisor Menu).

---

## 3.2.6 System info

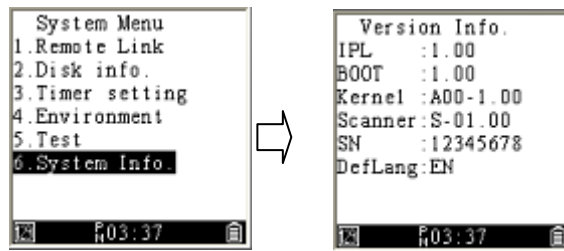

See the description in [Information](#) in User Menu.

## 3.3 Supervisor Menu

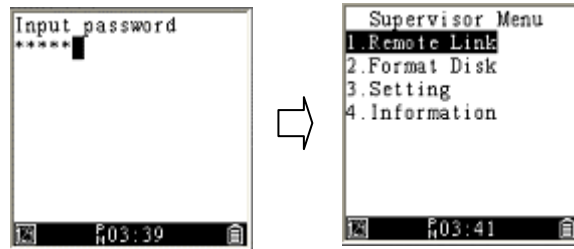

(1+3+0+PWR)Supervisor Menu provides advanced settings for you to configure. To protect the settings from being changed easily, you need to enter a password to access the menu. By default, the password is five zeros (00000).

### 3.3.1 Remote Link

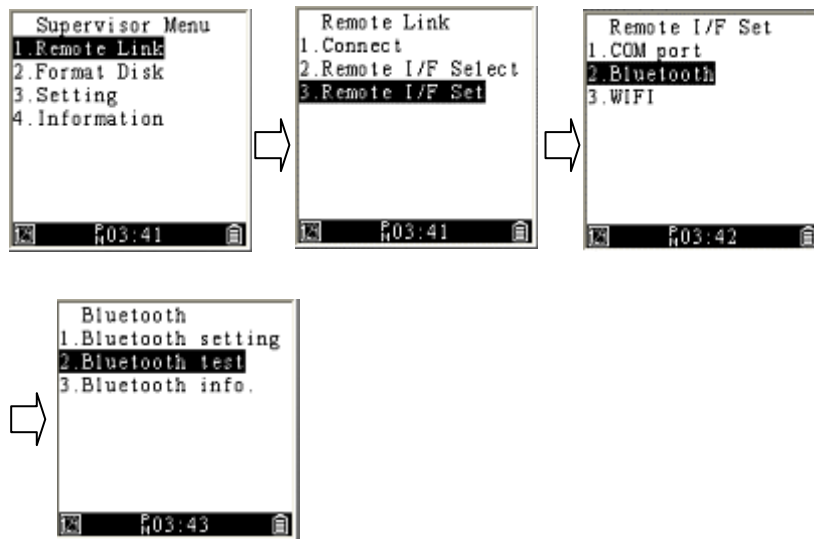

It is for you to connect your terminal with Everlink or PhoenixVoler to computer.

- **Connect** It connects your terminal to computer after you select an interface.
- **Remote I/F Select** It provides interfaces, including **COM port, Bluetooth and WI-FI.**
- **Remote I/F Set** It has three options:
  - **COM port** You can select a baud here.

- **Bluetooth** It has three options:
  1. Bluetooth setting:
    - (1) Device name: Your terminal's name. By default, the name is the serial number.
    - (2) PIN code: The passkey for a Bluetooth connection. By default, the code is four zeros (0000).
    - (3) Security mode: It has two options.
      - a. Security: Your terminal will ask other devices to enter a PIN code when they try to connect to your terminal.
      - b. Encryption: It encrypts the connection to prevent data theft.
    - (4) Inquiry timeout: It determines how long your terminal stops searching other devices after a certain amount of time elapses.
    - (5) Max response: It determines the maximum number of connectable devices your terminal lists.
    - (6) Set peer device: It has two options.
      - a. Set by search: Search other devices in the neighborhood.
      - b. Set by keyin: Search another device by



entering its Bluetooth MAC address.

2. Bluetooth test: You can use this option to test the Bluetooth connection after your terminal connects to a device.
  3. Bluetooth info: It displays Bluetooth information, including the local address, device name and link address.
- **WI-FI** It has three options
    1. Setting
      - (1) WI-FI SSID:
        - a. Set by search: Search WI-FI signal in the neighborhood.
        - b. Set by keyin: Type New SSID to connect the WI-FI you prefer.
      - (2) Network: It is the same as computer network. The Default is “Enable” DHCP to auto get IP Address, Subnet Mask and Gateway. Or you can “Disable” DHCP to set your WI-FI data.
      - (3) Connect setting: Type “New IP” and “New Port” to get connection.
      - (4) System Scale: There are 3 Level to choose. The default is “High”

- (5) Power Saving: If Disable, WI-FI module will always awake to transmit data. Otherwise, WI-FI will automatically turn off.
2. TCP Test: Test WI-FI connection, the process need to wait about 3~15 seconds. PI series will show the connect success of fail on the screen.
3. Information: It displays WI-FI information.
  - (1) Remote port: show the page is under remote port.
  - (2) MAC: Show MAC address after you connect.
  - (3) DHCP: The status is Enable or Disable.
  - (4) rIP: Current remote IP Address.
  - (5) rPort: Current remote Port.

### 3.3.2 Format disk

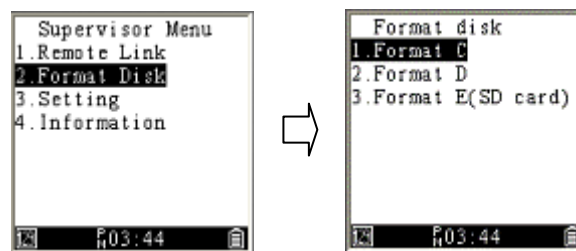

It formats a disk in your terminal. The system will ask you to confirm if you want to format, because it will remove all data stored in the disk.

- **Format C** Format the C disk.
- **Format D** Format the D disk.

### 3.3.3 Setting

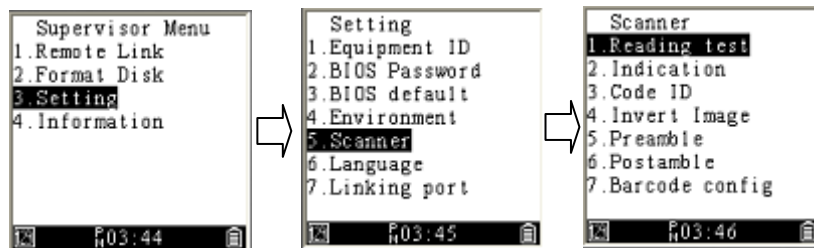

It offers a variety of settings that you can change to meet your need.

- **Equipment ID** Your terminal's ID. The default ID is four zeros (0000). You can replace it with a new ID. The ID needs to be a 4-digit number.
- **BIOS Password** It is the password of Supervisor Menu. The password needs to be a 5-digit number.
- **BIOS default** It resets all your terminal settings, including the password of Supervisor Menu.

- **Environment** It provides settings for you to adjust to adapt to different workplaces or match your preference. For the first five options, see the description in [Environment](#) in System Menu.
  - **Power on** It determines the screen displayed in User Menu after you turn on your terminal.
    1. Resume: The system displays the last screen you visited in User Menu every time you turn on your terminal.
    2. Reset: The system displays the default screen in User Menu every time you turn on your terminal.
  - **Status bar** You can choose if you want to display the status bar.
- **Scanner** It provides several settings for the scanning functionality.
  - **Reading test** See the description in [Test](#) in System Menu.
  - **Indication** It has two options:
    1. LED: You can turn on or turn off the LED.
    2. Beep: You can turn on or turn off beeps.
  - **Code ID** Code ID is an identifier for a bar code. It has two options:

1. **Transmission:** It has two modes: Proprietary ID or AIM ID. You can choose either of them. Proprietary ID is defined by Argox. AIM ID is defined by the AIM organization.
  2. **Position:** You can insert the code ID before or after the bar code data.
- **Invert Image** When you turn on this feature, you can scan both regular and inverted bar codes.
  - **Preamble** Add a character or characters before a bar code.
  - **Postamble** Add a character or characters after a bar code.
  - **Barcode config** It provides several settings for each bar code type. Change them to meet your need.

The list below shows the bar code types system default setting.

<i>Bar Code Type</i>	<i>ON</i>	<i>OFF</i>
1. <i>Code-11</i>	<input type="radio"/>	<input checked="" type="radio"/>
2. <i>Code-39</i>	<input checked="" type="radio"/>	<input type="radio"/>
3. <i>Code-93</i>	<input type="radio"/>	<input checked="" type="radio"/>
4. <i>Code-128</i>	<input checked="" type="radio"/>	<input type="radio"/>
5. <i>EAN-8</i>	<input type="radio"/>	<input checked="" type="radio"/>
6. <i>EAN-13</i>	<input checked="" type="radio"/>	<input type="radio"/>
7. <i>UPC-A</i>	<input type="radio"/>	<input checked="" type="radio"/>

8. <i>UPC-E</i>	<input type="radio"/>
9. <i>Industrial 25</i>	<input type="radio"/>
10. <i>Interleaved 25</i>	<input type="radio"/>
11. <i>Standard 25</i>	<input type="radio"/>
12. <i>MSI-Plessey</i>	<input type="radio"/>
13. <i>UK-Plessey</i>	<input type="radio"/>
14. <i>RSS 14</i>	<input type="radio"/>
15. <i>RSS Limited</i>	<input type="radio"/>
16. <i>RSS Expanded</i>	<input type="radio"/>
17. <i>CODABAR</i>	<input type="radio"/>
18. <i>Telepen</i>	<input type="radio"/>
19. <i>Matrix 2 of 5</i>	<input type="radio"/>
20. <i>China Post</i>	<input type="radio"/>
21. <i>Pharmacode</i>	<input type="radio"/>

- **Language** You can change the language for the system to display items in the user interface. It has two options: **English**, **TC** (Traditional Chinese) and **SC**(Simple Chinese).
- **Linking port** You can decide which port you want to use and configure its settings. To set a port, do this:
  1. In **Port IF select**, select a port and its interface.
  2. In **Port IF setup**, select the port you choose in the previous step, and configure the settings of its

interface.

- **Port IF select** It has four ports. Select one of them and choose its interface. You can choose **COM**, **USB**, **Bluetooth** and **WI-FI**. If you don't want to use interface, choose **None**.
- **Port IF setup** It provides the settings of **COM**, **Bluetooth** and **WI-FI**. For more information about the settings, see [Remote Link](#) in Supervisor Menu.
- **Port info** It displays the port information. Press **Up Arrow** and **Down Arrow** to check different ports.



**Important** **Linking port** is for development usage and transmit raw data. See more information, go to CH 2.3 [Connection](#)

---

- **Freq. set (PI-1060 Only)** Change PI-1060 Frequency setting to trigger Tag-60
  - **868** Set PI-1060 to RF 868 MHz frequency which is for Europe communication.
  - **920** Set PI-1060 to RF 920 MHz frequency which is for non Europe communication.

### 3.3.4 Information

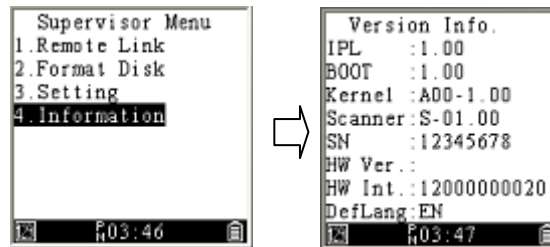

It displays your terminal's information.

<b>IPL</b>	The IPL version.
<b>BOOT</b>	The boot version.
<b>Kernel</b>	The kernel version.
<b>Scanner</b>	The scanner's firmware version.
<b>SN</b>	The serial number.
<b>HW Ver.</b>	The PCBA (Printed Circuit Board Assembly) version.
<b>HW Int.</b>	The hardware version.
<b>DefLang</b>	The display language.



## 4 Applications

Argox provides multiple applications for communication and developments as below:

### Communication

- |                |   |
|----------------|---|
| PhoenixVoler   | Upload and Download firmware or application easily. Recommend developer.                      |
| Everlink       | Manage multiple PI series with files transmission, message sending and history data function. |
| Control center | Remote-end of manage program can link multiple Everlink and provide Cloud operation.          |

### Development application

- |           |  |
|-----------|--|
| Skywalker | User friendly software development kit |
|-----------|--|

**Go to Argox website to get more applications and user guide**

<http://www.argo.com/content2011.php?sno=0000033>



---

**Note** PI Series accept “.bas” and “.bin” file from Basic and C compiler.

---

# 5 Troubleshooting

## 5.1 Hardware issues

### **Speaker is not working or volume is too low.**

- Make sure the speaker hole is not blocked.
- Test is in the system menu, use [Test](#) to check speaker.

### **Keypad does not response.**

- Test is in the system menu, use [Test](#) to check keypad.
- The system might be crush. Use Scan + Power key to warm reset or cold reset (hold 5 seconds).

### **My terminal keeps turning itself off or can not open.**

- If you're using batteries, check them and see if they need to be charged.
- If your terminal is connected using USB or RS-232 cable, make sure the cable is tightly plugged.
- The duration of Auto off Timer is too short. Set it a longer duration from **Auto off timer** in [Environment](#)

## 5.2 Communication issues

### Receive or transmit problem on USB

- Check USB connector is plugged correctly.
- Check Remote Link set is USB and select the right PI series name on computer.
- Restart PI series and unplug the USB and try again.

### Receive or transmit problem on RS-232

- Check RS-232 connector is plugged correctly.
- Check Remote Link set is COM port and select the same port on computer.
- Restart PI series and unplug the RS-232 and try again.

### Receive or transmit problem on Bluetooth

- Check Remote Link set is Bluetooth port and [Bluetooth setting](#) is correct.
- Be sure PI series is in the Bluetooth range

## 5.3 Barcode scanning issues

### Barcode can not be read

- Change the angle between the bar code and the terminal.
- Change the distance between the bar code and the terminal.
- Clean the scanning window slightly of the terminal(make sure without scratch).
- Enabled the bar code symbology in supervisor menu > 3.Setting > 5.Scanner > 7.[Barcode config](#).

## 6 Specifications

<b>General Characteristics</b>	
<b>OS</b>	Argox Proprietary
<b>CPU</b>	ARM926EJ-S
<b>RAM</b>	16 / 32 MB DRAM
<b>ROM</b>	20 / 60 MB Flash
<b>Display</b>	White gray mono STN LCD 160*160
<b>Indicator</b>	LED Blue, Green and Red; Beeper; Vibration Motor
<b>Keypad</b>	25 Alpha-Numeric keys (Including 10 function keys, 3 programmable hot keys)
<b>Accessory</b>	Holder (Standard), Power Supply
<b>Dimensions</b>	145.0mm (L) x 55.0mm (W) x 26.0mm (H)
<b>Weight</b>	230g with battery

Specifications

<b>Model</b>	<b>PI-1010</b>	<b>PI-1030</b>	<b>PI-1060</b>	<b>PI-1230</b>
<b>WPAN</b>	Bluetooth Class2, BT2.1+EDR			
<b>WLAN</b>	N/A	Wi-Fi 802.11b/g /n	N/A	Wi-Fi 802.11b/g /n
<b>RF</b>	N/A	N/A	+15dbm max. ( Max output power)	N/A
<b>I/O Interface</b>	USB 2.0 / RS-232			

<b>Scanner</b>					
<b>Model</b>	PI-1010/PI-1030/PI-1060		PI-1230		
<b>Scanner system</b>	CCD		2D Area imager		
<b>Resolution</b>	3 mil at PCS 90%		1D(5 mils):Code 39 2D(6.7miks): PDF417		
<b>Depth of field</b>	Code39	3mil	40-90 mm	Code39	5mil
		5mil	45-140 mm	EAN 13	13mil
	EAN 13	20mil	65-570 mm	Datamatrix	15mil
		13mil	55-435 mm		
<b>Scanning rate</b>	200 scan/sec				
<b>Decode capability</b>	Code-11 、 Code-39 、 Code-93 、 Code-128 、 EAN-8 、 EAN-13 、 UPC-A 、 UPC-E 、 Industrial 25 、 Interleaved 25 、 Standard 25 、 MSI-Plessey 、 UK-Plessey 、 RSS 14 、 RSS Limited 、 RSS Expanded 、		Auto discriminates all standard one-dimension barcodes; including GS1 databar PDF417, MicroPDF, Composite Codes(CC-A, CC-B,		

<p>CODABAR 、 Telepen 、 Matrix 2 of 5 、 China Post 、 Pharmacode</p>	<p>CC-C) OCR-A, OCR-B,OCR-C, Aztec (Standard, Inverse), MaxiCode, DataMatrix/ECC 200 (Standard, Inverse), QR Code , Micro QR</p>
--	--

### Expansion

**Storage**      Micro SD (up to 16 GB)(factory option)

### Developing Tools

**Software**      Software Development Kit (SDK),  
Skywalker (Proprietary application  
software generator)

**Programming Language**    C language, BASIC language

### Power

**Battery**      AA size NIMH Battery \*2 (charged by USB  
or optional power adapter) or AA size  
Alkaline \*2  
( Recommend AA size NIMH Battery for  
daily work)



## Specifications

### Power

**Rating** 5Vdc 2A

### Physical and Environment

**Operating Temperature** -10°C ~ 60°C / 14F ~ 140F

---

#### Temperature

**Storage Temperature** -20°C ~ 70°C / -4F ~ 158F

---

#### Temperature

**Humidity** 1) Operating: Non-condensed 10 ~ 90%

2) Storage: Non-condensed 5 ~ 95%

---

**Impact** 1) Terminal 1.2M/4ft

**Resistance** 2) IP54

---

**Electrostatic Discharge** 1) +/- 15 KV air discharge 2) +/- 8 KV

direct discharge

---

**EMC** FCC, CE, BIS, BSMI

#### Regulation

<b>Model</b>	<b>TAG-60</b>
<b>Light indication</b>	Blue LED
<b>Sound alert</b>	Buzzer >80dbA @ 10cm, programmable sound pattern
<b>Beeping pattern</b>	Programmable beeping pattern
<b>RF Sensitivity</b>	-110 dbm typ.
<b>Frequency bands (TBD)</b>	410~475, 820~950 MHz
<b>Power</b>	CR-2032 coin battery, 1 years standby minimum
<b>Drop</b>	1.5M
<b>Dimensions</b>	76.0mm (L) x 50.0mm (W) x 17.0mm (H)

# Appendix A

## Scan Module (CCD) Configuration Table

Default (\*)

Command1	Command2	Option/Limitation
Indication	LED indication	Disable
		Enable *
	Buzzer indication	Disable
		Enable *
Transmission	Preamble transmission	Disable *
		Enable
	Postamble transmission	Disable *
		Enable
	Code ID position	Before code data *
		After code data
	Code ID transmission	Disable *
		Proprietary ID
		AIM ID
	Code length transmission	Disable *
Enable		
Code name transmission	Disable *	
	Enable	
		Disable *

	Case conversion	Upper case Lower case
		0 ~ 9
Scan	Double confirm	0 *
		0 ~ 99
	Global min. code length	4 *
	Global max. code length	63 *
		Disable *
	Inverted image scan	Enable
String setting	Prefix characters setting	0 * 0x00 ~ 0xff ASCII code 12 characters.
	Suffix characters setting	0 * 0x00 ~ 0xff ASCII code 12 characters.
	Preamble characters settings	0 * 0x00 ~ 0xff ASCII code 12 characters.
	Postamble characters settings	0 * 0x00 ~ 0xff ASCII code 12 characters.
Code 11	Read	Enable

		Disable/Disable
	Check-sum transmit /verify	Disable/One digit *
		Disable/Two digits
		Enable/One digit
		Enable/Two digits
	Max. code length	0 ~ 64
		0 *
	Min. code length	0 ~ 64
		0 *
	Truncate leading	0 ~ 15
		0 *
	Truncate ending	0 ~ 15
		0 *
	Code ID setting	<O> 0x00 ~ 0xff ASCII code(1 or 2 bytes)
Code 39	Read	Disable Enable *
	Check-sum transmit /verify	Disable/Disable * Disable/Enable Enable /Enable
	Max. code length	0 ~ 64 0 *
	Min. code length	0 ~ 64

		1 *
	Truncate leading	0 ~ 20
		0 *
	Truncate ending	0 ~ 15
		0 *
		<*>
	Code ID setting	0x00 ~ 0xff ASCII code(1 or 2 bytes)
		Standard *
	Format	Full ASCII
		Disable *
	Start/stop transmission	Enable
		Disable *
Code 93	Read	Enable
		Disable/Disable
	Check-sum transmit /verify	Disable/Enable *
		Enable /Enable
		0 ~ 64
	Max. code length	0 *
		0 ~ 64
	Min. code length	0 *
		0 ~ 15
	Truncate leading	0 *
		0 ~ 15
	Truncate ending	0 *

	Code ID setting	<&> 0x00 ~ 0xff ASCII code(1 or 2 bytes)
Code 128	Read	Disable Enable *
	Check-sum transmit /verify	Disable/Disable Disable/Enable * Enable /Enable
	Max. code length	0 ~ 64 0 *
	Min. code length	0 ~ 64 1 *
	Truncate leading	0 ~ 15 0 *
	Truncate ending	0 ~ 15 0 *
	Code ID setting	<#> 0x00 ~ 0xff ASCII code(1 or 2 bytes)
	Format	Standard * UCC.EAN 128
	UCC/EAN 128 ID setting	<#> 0x00 ~ 0xff ASCII code(1 bytes)
		0x1D *

	Concatenation code	0x00 ~ 0xff ASCII code(1 bytes)
Codabar		Disable *
	Read	Enable
		Disable/Disable *
	Check-sum transmit /verify	Disable/Enable Enable /Enable
		0 ~ 64
	Max. code length	0 *
		0 ~ 64
	Min. code length	0 *
		0 ~ 15
	Truncate leading	0 *
		0 ~ 15
	Truncate ending	0 *
		<%>
	Code ID setting	0x00 ~ 0xff ASCII code(1 or 2 bytes)
		ABCD/ABCD *
Start/stop type	abcd/abcd ABCD/TN*E abcd/tn*e	
	Disable *	
Start/stop transmission	Enable	
	Disable	



Appendix A

EAN 8	Read	Enable *
		Disable
	Check-sum transmission	Enable *
		0 ~ 15
	Truncate leading	0 *
		0 ~ 15
	Truncate ending	0 *
		<FF>
	Code ID setting	0x00 ~ 0xff ASCII code(1 or 2 bytes)
		None *
	Supplement digits	2 digits 5 digits 2, 5 digits UCC/EAN 128 2, UCC/EAN 128 5, UCC/EAN 128 All
		None *
	Truncation/expansion	Truncate leading zero Expand to EAN 13
		Disable *
Expansion	Enable	
	Disable	
EAN 13	Read	Enable *

	Check-sum transmission	Disable Enable *
	Truncate leading	0 ~ 15 0 *
	Truncate ending	0 ~ 15 0 *
	Code ID setting	<F> 0x00 ~ 0xff ASCII code(1 or 2 bytes)
	Supplement digits	None * 2 digits 5 digits 2, 5 digits UCC/EAN 128 2, UCC/EAN 128 5, UCC/EAN 128 All
	ISBN/ISSN conversion	Disable * Enable
Industrial 2 of 5	Read	Disable * Enable
	Max. code length	0 ~ 64 0 *
	Min. code length	0 ~ 64 0 *

		0 ~ 15
	Truncate leading	0 *
		0 ~ 15
	Truncate ending	0 *
		<i>
	Code ID setting	0x00 ~ 0xff ASCII code(1 or 2 bytes)
Interleaved 2 of 5	Read	Disable Enable *
		Disable/Disable *
	Check-sum transmit /verify	Disable/Enable Enable /Enable
		0 ~ 64
	Max. code length	0 *
		0 ~ 64
	Min. code length	0 *
		0 ~ 15
	Truncate leading	0 *
		0 ~ 15
	Truncate ending	0 *
		<i>
	Code ID setting	0x00 ~ 0xff ASCII code(1 or 2 bytes)
Standard 2 of 5	Read	Disable * Enable

		Disable/Disable *
	Check-sum transmit /verify	Disable/Enable Enable /Enable
	Max. code length	0 ~ 64 0 *
	Min. code length	0 ~ 64 0 *
	Truncate leading	0 ~ 15 0 *
	Truncate ending	0 ~ 15 0 *
	Code ID setting	<i> 0x00 ~ 0xff ASCII code(1 or 2 bytes)
MSI Plessey	Read	Disable * Enable
	Check-sum transmit /verify	N/disable * N/MOD 10 N/Mod 10,10 N/mod 11,10 Y/ Mod10 Y/ Mod 10,10 Y/ Mod 11/10

		0 ~ 64
	Max. code length	0 *
		0 ~ 64
	Min. code length	0 *
		0 ~ 15
	Truncate leading	0 *
		0 ~ 15
	Truncate ending	0 *
		<@>
	Code ID setting	0x00 ~ 0xff ASCII code(1 or 2 bytes)
		Disable *
UK Plessey	Read	Enable
		Disable/Disable
	Check-sum transmit /verify	Disable/Enable *
		Enable /Enable
		0 ~ 64
	Max. code length	0 *
		0 ~ 64
	Min. code length	0 *
		0 ~ 15
	Truncate leading	0 *
		0 ~ 15
	Truncate ending	0 *
		<@>

Appendix A

	Code ID setting	0x00 ~ 0xff ASCII code(1 or 2 bytes)
Telepen		Disable *
	Read	Enable
		Disable/Disable *
	Check-sum transmit /verify	Disable/Enable Enable /Enable
		0 ~ 64
	Max. code length	0 *
		0 ~ 64
	Min. code length	0 *
		0 ~ 15
	Truncate leading	0 *
		0 ~ 15
Truncate ending	0 *	
	<S>	
Code ID setting	0x00 ~ 0xff ASCII code(1 or 2 bytes)	
	Numeric *	
Format	Full ASCII	
UPCA		Disable
	Read	Enable *
		Disable
	Check-sum transmission	Enable *

		0 ~ 15
	Truncate leading	0 *
		0 ~ 15
	Truncate ending	0 *
		<A>
	Code ID setting	0x00 ~ 0xff ASCII code(1 or 2 bytes)
		None *
	Supplement digits	2 digits 5 digits 2, 5 digits UCC/EAN 128 2, UCC/EAN 128 5, UCC/EAN 128 All
		None
	Truncate/expansion	Truncate leading zero * Expand to EAN 13
UPCE		Disable
	Read	Enable *
		Disable
	Check-sum transmission	Enable *
		0 ~ 15
	Truncate ending	0 *
		<E>

	Code ID setting	0x00 ~ 0xff ASCII code(1 or 2 bytes)
		None *
	Supplement digits	2 digits 5 digits 2, 5 digits UCC/EAN 128 2, UCC/EAN 128 5, UCC/EAN 128 All
		None *
	Truncate/expansion	Truncate leading zero Expand to EAN 13 Expand to UPCA
		Disable *
	Expansion	Enable
		Disable *
	UPCE-1	Enable
		Disable *
Matrix 25	Read	Enable
		Disable/Disable *
	Check-sum transmit /verify	Disable/Enable Enable /Enable
		0 ~ 64
	Max. code length	0 *



Appendix A

		0 ~ 64
	Min. code length	0 *
		0 ~ 15
	Truncate leading	0 *
		0 ~ 15
	Truncate ending	0 *
		<B>
	Code ID setting	0x00 ~ 0xff ASCII code(1 or 2 bytes)
		Disable *
China post	Read	Enable
		0 ~ 64
	Max. code length	11 *
		0 ~ 64
	Min. code length	11 *
		0 ~ 15
	Truncate leading	0 *
		0 ~ 15
	Truncate ending	0 *
		<t>
	Code ID setting	0x00 ~ 0xff ASCII code(1 or 2 bytes)
		Disable *
RSS 14	Read	Enable
		0 ~ 15
	Truncate leading	0 *

		0 ~ 15
	Truncate ending	0 *
		<R4>
	Code ID setting	0x00 ~ 0xff ASCII code(1 or 2 bytes)
		Disable *
	UCC/EAN 128 emulation	Enable
		Disable *
RSS Limited	Read	Enable
		0 ~ 15
	Truncate leading	0 *
		0 ~ 15
	Truncate ending	0 *
		<RL>
	Code ID setting	0x00 ~ 0xff ASCII code(1 or 2 bytes)
		Disable *
	UCC/EAN 128 emulation	Enable
		Disable *
RSS Expanded	Read	Enable
		0 ~ 99
	Max. code length	99 *
		0 ~ 99
	Min. code length	1 *

		0 ~ 15
	Truncate leading	0 *
		0 ~ 15
	Truncate ending	0 *
		<RX>
	Code ID setting	0x00 ~ 0xff ASCII code(1 or 2 bytes)
		Disable *
	UCC/EAN 128 emulation	Enable
		Disable *
Italian	Read	Enable
Pharmacode 39		0 ~ 64
	Max. code length	12 *
		0 ~ 64
	Min. code length	9 *
		0 ~ 15
	Truncate leading	0 *
		0 ~ 15
	Truncate ending	0 *
		<p>
	Code ID setting	0x00 ~ 0xff ASCII code(1 or 2 bytes)
		Disable *
	Leading "A"	Enable

# Appendix B

## Scan Module (2D) Configuration Table

Default (\*)

Command1	Command2	Value
5 Indication	2 LED indication	0: Disable 1: Enable *
	3 Buzzer indication	0: Disable 1: Enable *
	4 Vibrator	0: Disable 1: Enable *
	6 Transmission	8 Transmit Code ID
7 Scan	17 Timeout	5~99(0.1 sec.) Default: 99(9.9 sec)
	20 Trigger Mode	0: Trigger(*) 7: Hand-Free Mode 9: Auto
	21 Picklist Mode	0: Disable(*) 2: Enable
	22 Same Barcode Timeout	5~99(0.1 sec.) Default: 6 (0.6 sec)
	23 Mobile Mode	Phone/Display 0: Disable(*) 3: Enable

Appendix B

	27	1~10 (default: 10)
	Illumination Power Level	
	28	0: Disable
	Decoding Illumination	1: Enable(*)
	29	0: Disable
	Decode Aiming Pattern	2: Enable(*)
	32	0: Regular(*)
	Inverse 1D	1: Inverse
		2: Inverse Autodetect
10	1	0: Disable(*)
Code 11	Read	1: Enable
	2	0: Disable(*)
	Check Digit Verification	1: 1 Check Digit
		2: 2 Check Digits
	3	0: Disable(*)
	Transmit Check Digit(s)	1: Enable
	4	0 ~ 55 (default: 4)
	Length 1※1	
	5	0 ~ 55 (default: 55)
	Length 2※1	
11	1	0: Disable
Code 39	Read	1: Enable(*)
	2	0: Disable(*)
	Check Digit Verification	1: Enable
	3	0: Disable(*)
	Transmit Check Digit	1: Enable
	4	0 ~ 55 (default: 2)
	Length 1※1	

Appendix B

	5 Length 2※1	0 ~ 55 (default: 55)
	10 Full ASCII Conversion	0: Disable(*) 1: Enable
	19 Code 32 Prefix	0: Disable(*) 1: Enable
	20 Trioptic Code 39	0: Disable(*) 1: Enable
	21 Convert Code 39 to Code 32	0: Disable(*) 1: Enable
12 Code 93	1 Read	0: Disable(*) 1: Enable
	4 Length 1※1	0 ~ 55 (default: 4)
	5 Length 2※1	0 ~ 55 (default: 55)
13 Code 128	1 Read	0: Disable 1: Enable(*)
	4 Length 1※1	0 ~ 55 (default: 0)
	5 Length 2※1	0 ~ 55 (default: 0)
	14 ISBT 128	0: Disable 1: Enable(*)
	15 GS1-128	0: Disable 1: Enable(*)
	19 ISBT Concatenation	0: Disable(*) 1: Enable

## Appendix B

		2: Auto
	20 Check ISBT Table	0: Disable 1: Enable(*)
	21 ISBT Concatenation Redundancy	2 ~ 20 (default: 10)
14 Codabar	1 Read	0: Disable(*) 1: Enable
	4 Length 1※1	0 ~ 55 (default: 5)
	5 Length 2※1	0 ~ 55 (default: 55)
	14 CLSI Editing	0: Disable(*) 1: Enable
	15 NOTIS Editing	0: Disable(*) 1: Enable
15 EAN 8/JAN 8	1 Read	0: Disable 1: Enable(*)
	20 Zero Extend	0: Disable(*) 1: Enable
16 EAN 13/JAN 13	1 Read	0: Disable 1: Enable(*)
18 Interleaved 2 of 5	1 Read	0: Disable 1: Enable(*)
	2 Check Digit Verification	0: Disable(*) 1: USS Check Digit 2: OPCC Check Digits
	3 Transmit Check Digit	0: Disable(*) 1: Enable

Appendix B

	4	0 ~ 55 (default: 14)
	Length 1※1	
	5	0 ~ 55 (default: 0)
	Length 2※1	
	9	0: Disable(*)
	Convert to EAN 13	1: Enable
20	1	0: Disable(*)
MSI Plessey	Read	1: Enable
	2	0: One Check Digit(*)
	Check Digits	1: Two Check Digits
	3	0: Disable(*)
	Transmit Check Digit	1: Enable
	4	0 ~ 55 (default: 4)
	Length 1※1	
	5	0 ~ 55 (default: 55)
	Length 2※1	
	9	0: MOD 10/MOD 11
	Check Digit Algorithm	1: MOD 10/MOD 10(*)
23	1	0: Disable
UPCA	Read	1: Enable(*)
	3	0: Disable
	Transmit Check Digit	1: Enable(*)
	20	0: Disable
	UPC-A Preamble	1: System Character Only(*)
		2: System Character and Country Code
24	1	0: Disable
UPCE	Read	1: Enable(*)



	3		0: Disable
	Transmit Check Digit		1: Enable(*)
	13		0: Disable(*)
	UPC-E1		1: Enable
	14		0: Disable(*)
	Convert UPC-A	UPC-E to	1: Enable
	20		0: Disable
	Transmit Check Digit	UPC-E1 Check Digit	1: Enable(*)
	21		0: Disable(*)
	Convert UPC-A	UPC-E1 to	1: Enable
	22		0: Disable
	UPC-E Preamble		1: System Character Only(*)
			2: System Character and Country Code
	23		0: Disable
	UPC-E1 Preamble		1: System Character Only(*)
			2: System Character and Country Code
25	1		0: Disable(*)
Matrix 2 of 5	Read		1: Enable
	2		0: Disable(*)
	Check Digit		1: Enable
	3		0: Disable(*)
	Transmit Check Digit		1: Enable
	4		0 ~ 55 (default: 14)
	Length 1※1		
	5		0 ~ 55 (default: 0)
	Length 2※1		

Appendix B

26 PDF-417	1 Read	0: Disable
		1: Enable(*)
33 MicroPDF	1 Read	0: Disable(*)
		1: Enable
	11 Code 128 Emulation	0: Disable(*)
		1: Enable
35 UPC/EAN	1 Bookland EAN	0: Disable(*)
		1: Enable
	2 Bookland ISBN Format	0: Bookland ISBN-10(*)
		1: Bookland ISBN-13
	3 UCC Coupon Extended Code	0: Disable(*)
		1: Enable
	5 Supplemental	0: Ignore supplemental (*)
		1: Decode with Supplemental only
		2: Auto discriminate Supplemental
		3: Smart Supplemental Mode
		※ Applies to EAN-13 starting with any prefix listed previously
		4: Enable 378/379 Supplemental
		5: Enable 978/979 Supplemental
		※ If you select 978 Supplemental Mode and are scanning Bookland EAN bar codes, you should enable Bookland EAN, and select a format using

	Bookland Format.	ISBN
6:	414/419/434/439 Supplemental	Enable
7:	Supplemental	Enable 977
8:	Supplemental	Enable 491
9:	1 User-Programmable Type 1	Supplemental
	※ Applies to EAN-13 bar codes starting with a 3-digit user-defined prefix. Set this 3-digit prefix using User-Programmable Supplemental.	
10:	1 and 2 User-Programmable Type 1 and 2	Supplemental
	※ Applies to EAN-13 bar codes starting with either of two 3-digit user-defined prefixes. Set the 3-digit prefixes using User-Programmable Supplemental.	
11:	Plus User-Programmable 1	Smart Supplemental
	※ Applies to EAN-13 bar codes starting with any prefix listed previously or the user-defined prefix set using	

		User-Programmable Supplemental.
		12: Smart Supplemental Plus User-Programmable 1 and 2
		※ Applies to EAN-13 bar codes starting with any prefix listed previously or one of the two user-defined prefixes set using <i>User-Programmable Supplemental.</i>
	6 Supplemental Redundancy	2 ~ 30 (default: 10)
	7 User-Programmable Supplemental 1	-1 ~ 999(default:-1)
	8 User-Programmable Supplemental 2	-1 ~ 999(default:-1)
	9 UPC/EAN/JAN Supplemental Format	0: Separate 1: Combined(*) 2: Separate Transmission
	10 Coupon Report	0: Old Coupon Symbols 1: New Coupon Symbols(*) 2: Both Coupon Formats
	11 ISSN EAN	0: Disable(*) 1: Enable
45 Australia Post	1 Read	0: Disable 1: Enable(*)
	2	0: Auto(*)

Appendix B

	Format	1: Raw Format 2: Alphanumeric Encoding 3: Numeric Encoding
48 Japan Postal	1 Read	0: Disable 1: Enable(*)
49 KIX Code	1 Read	0: Disable 1: Enable(*)
51 USPS	1 Read	0: Disable(*) 1: Enable
52 UPU	1 Read	0: Disable(*) 1: Enable
53 Aztec	1 Read	0: Disable 1: Enable(*)
	10 Inverse	0: Regular(*) 1: Inverse 2: Auto
54 Data Matrix	1 Read	0: Disable 1: Enable(*)
	6 Inverse	0: Regular(*) 1: Inverse 2: Auto
55 Maxicode	1 Read	0: Disable 1: Enable(*)
58 OCR	1 Read	0: OCR off (*) 1: OCR-A 2: OCR-B 3: US Currency 4: MICR E13B

2 OCR-A Variant ※2	0: OCR-A Full ASCII(*)	
	1: OCR-A Reserved 1	
	2: OCR-A Reserved 2	
	3: OCR-A Banking	
3 OCR-B Variant ※3	0: OCR-B Full ASCII(*)	
	1: OCR-B Banking	
	2: OCR-B Limited	
	3: OCR-B Travel Document Version 1 (TD1) 3 Line ID Cards	
	4: OCR-B Passport	
	6: OCR-B ISBN 10-Digit Book Numbers	
	7: OCR-B ISBN 10 or 13-Digit Book Numbers	
	8: OCR-B Travel Document Version 2 (TD2) 2-Line ID Cards	
	9: OCR-B Visa Type A	
	10: OCR-B Visa Type B	
	14: Travel Document 2 or 3-Line ID Cards Auto-Detect	
	4 OCR Orientation	0: OCR Orientation 0(*)
		1: OCR Orientation 270 Clockwise
		2: OCR Orientation 180 Clockwise
3: OCR Orientation 90 Clockwise		
4: OCR Orientation Omnidirectional		
5 OCR Lines	1: OCR 1 Line(*)	
	2: OCR 2 Line	

		3: OCR 3 Line	
	6	3(*)	
	OCR Minimum Characters	Range:3~100	
	7	100(*)	
	OCR Maximum Characters	Range:3~100	
	8	50(*)	
	OCR Quiet Zone	Range:20~99	
	9	0: Regular Only(*)	
	Inverse OCR	1: Inverse Only	
		2: Autodiscriminate	
59 Discrete 2 of 5	1	0: Disable(*)	
	Read	1: Enable	
	4	0 ~ 55 (default: 12)	
	Length 1※1		
		5	0 ~ 55 (default: 0)
		Length 2※1	
60 Chinese 2 of 5	1	0: Disable(*)	
	Read	1: Enable	
61 GS1 Data Bar	1	0: Disable	
	GS1 DataBar-14	1: Enable(*)	
	2	0: Disable(*)	
	GS1 DataBar Limited	1: Enable	
	3	0: Disable(*)	
	GS1 DataBar Expanded	1: Enable	
	4	0: Disable(*)	
	Convert to UPC/EAN	1: Enable	
	5	1: Level 1	
	GS1 DataBar Limited Security Level	2: Level 2	
		3: Level 3(*)	

Appendix B

			4: Level 4
62 Korean 3 of 5	1 Read	0: Disable(*)	
		1: Enable	
63 Postal codes	1 US Postnet	0: Disable	
		1: Enable(*)	
	2 US Planet	0: Disable	
		1: Enable(*)	
	3 Transmit US Postal Check Digit	0: Disable	
1: Enable(*)			
4 UK Postal	0: Disable		
	1: Enable(*)		
5 Transmit UK Postal Check Digit	0: Disable		
	1: Enable(*)		
64 Composite	1 Composite CC-C	0: Disable(*)	
		1: Enable	
	2 Composite CC-A/B	0: Disable(*)	
		1: Enable	
	3 Composite TLC-39	0: Disable(*)	
1: Enable			
4 UPC Composite Mode	0: UPC Never Linked(*)		
	1: UPC Always Linked		
5 GS1-128 Emulation Mode for UCC/EAN Composite Codes	0: Disable(*)		
	1: Enable		
65 QR Code	1 Read	0: Disable	
		1: Enable(*)	
	2	0: Regular(*)	



Appendix B

	Inverse	1: Inverse
		2: Auto
66	1	0: Disable
Micro QR	Read	1: Enable(*)
68	1	1: Level 1(*)
Symbology	Redundancy Level	2: Level 2
Specific Security		3: Level 3
Levels		4: Level 4
	2	0: Level 0
	Security Level	1: Level 1(*)
		2: Level 2
		3: Level 3
	3	6:Normal(*)
	Intercharacter Gap Size	10:Large