



**MODEL : LK-P11W**  
MOBILE PRINTER

All specifications are subject to change without notice



**RISK OF EXPLOSION IF BATTERY IS REPLACED BY AN INCORRECT TYPE.  
DISPOSE OF USED BATTERIES ACCORDING TO THE INSTRUCTIONS**

---



**Disposal of Old Electrical & Electronic Equipment (Applicable in the European Union and other European countries with separate collection systems)**

This symbol on the product or on its packaging indicates that this product shall not be treated as household waste.

Instead it shall be handed over to the applicable collection point for the recycling of electrical and electronics equipment. For more detailed information about recycling of this product, please contact your local city office, your household waste disposal service or the shop where you purchased the product.

## Table of Contents

1. Product overview	3
2. Unpacking	4
3. Installation & Usage	5
3-1. Battery Installation	5
3-2. Battery Charging	6
3-3. Belt Strap Usage	7
3-4. Separation of Battery from the printer	8
3-5. Shoulder Strap Usage	9
3-6. Leather case Usage	10
3-7. Loading the paper	11
3-8. Control Panel Usage	12
3-9. Self Test	13
4. Peripherals Connection	15
4-1. Wifi(802.11b/g) Connection	15
4-2. Interface Cable Connection	16
5. Printer Cleaning	17
6. Product Specification	18
6-1. Specification	18

## 1. Product overview

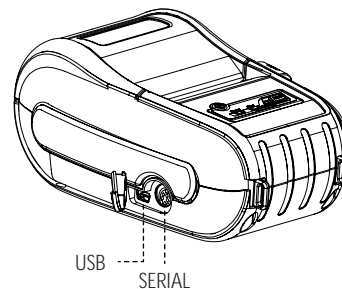
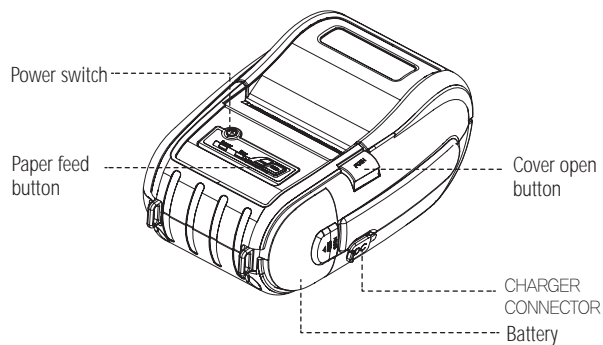

## 2. Unpacking

### Standard

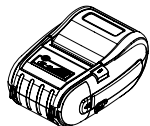

Printer

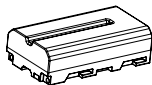

Battery



Belt Buckle

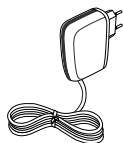

Recharger

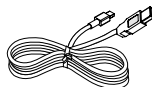

USB Shilded Cable

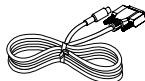

Serial Cable

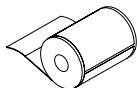

Roll paper



CD



Quick Manual

### Option



Printer case

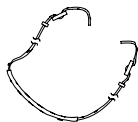

shoulder strap

## 3. Setting Up the Product

### 3-1. Installing battery

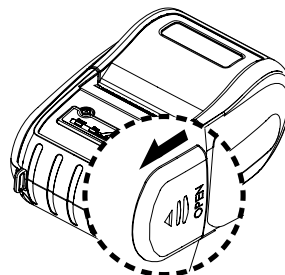

Push the Open to the direction as pointed by arrow in the image.

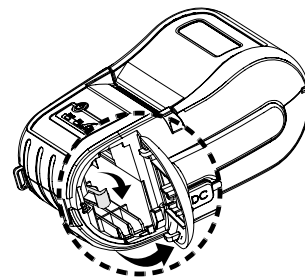

Open the battery cover and push up the hook to the direction as above.

1 2  
3

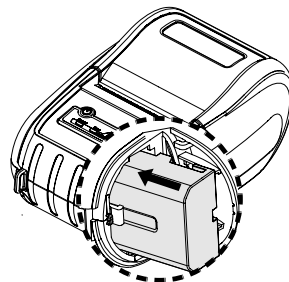

Insert the battery inside printer as shown.

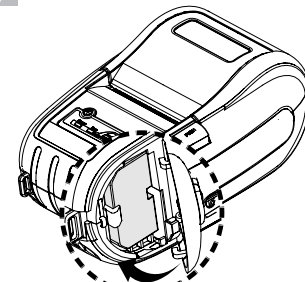

Close the battery cover once you inserted the battery completely.

**Notes:** as the battery is not charged at the time of your purchase, charge the battery prior to using the product.  
(Use the battery charger and/or the optional battery holder.)

### 3-2. Battery Charging

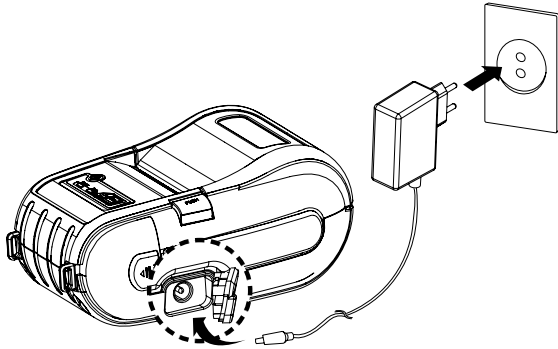

1. The battery can be charged only when the temperature is 0~40°C
2. Be sure that the printer is turn off and the battery to be charged is installed.
3. Connect the charger to the printer.
4. Recharging will now be started.

#### Notes:

1. Do not turn on the printer power while you are charging the battery.
2. Do not print while charging the battery
3. Do not connect the charger to the printer on the process of printing.

### 3-3. Belt Hook Usage

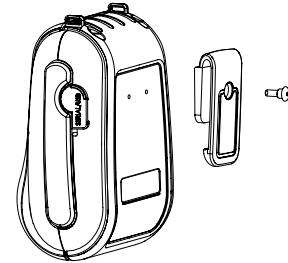

Insert the belt hook screw into the hole of the belt hook.

1  
2

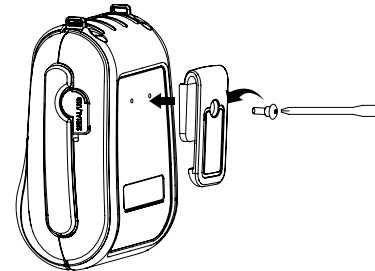

As shown above, fasten the screw with a screw driver.

### 3-4. Removing battery

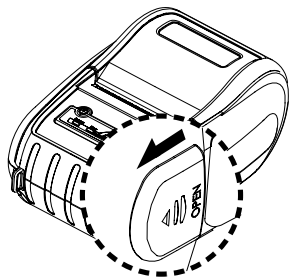

Push the Open into the direction indicated with the arrow in the image.

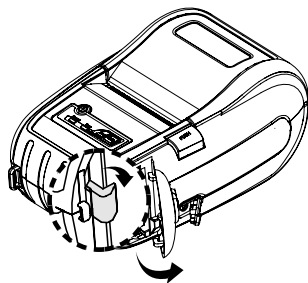

Push up the hook after opening the battery cover.

1 2  
3

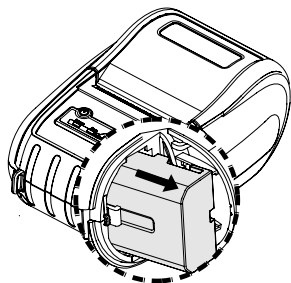

Pull out the battery as shown above.

### 3-5. Shoulder Strap Usage

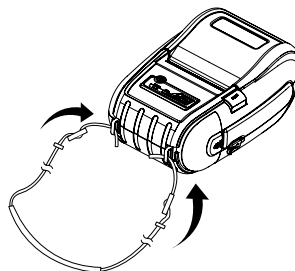

Insert the strap into the hook on the printer.

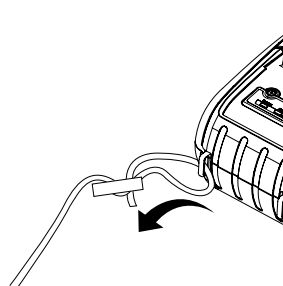

Place the end of strap into the hook of shoulder strap.

1 2  
3 4

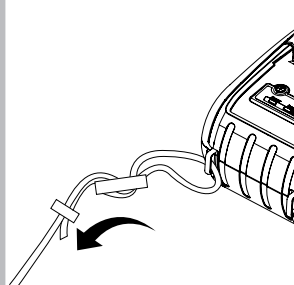

After pulling out the end of strap tightly, put it into the clip to be fastened.

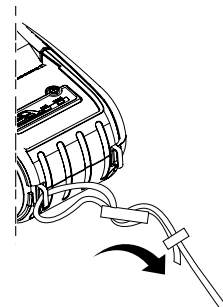

Fasten the strap in the opposite side with the sample way.

### 3-6. Leather Case Usage

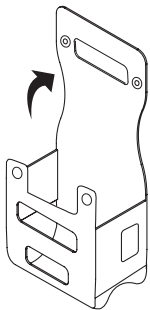

Open the Velcro

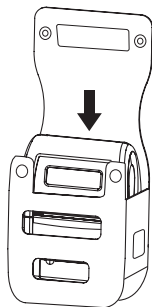

Put the printer into the leather case following the direction shown in the

1 2  
3

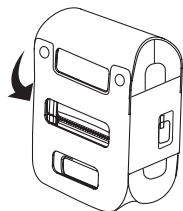

Close the Velcro

### 3-7. Loading the media.

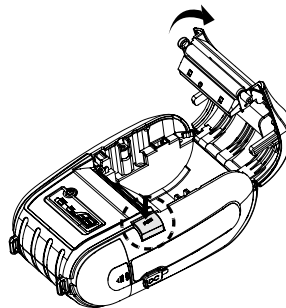

Press the cover open button and open

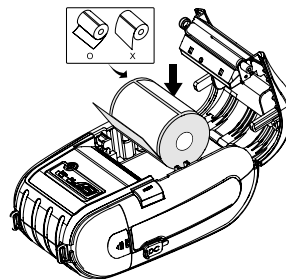

Place the paper roll as shown. Make sure the paper is placed in right direction.

1 2  
3 4

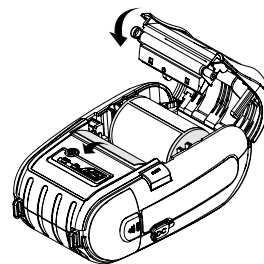



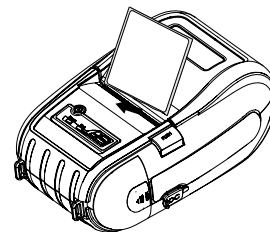

Pull a short length of paper out of the printer and close the cover.

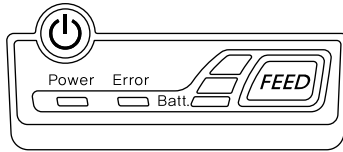

Press Feed button and let the paper be arranged properly for printing.

### 3-8. Control Panel



Button	Name	function
	Power button	This button is used to turn the printer on and off. When the printer is off, press this button for approximately 2 seconds and it will turn on the power. When you press this button in a state that the printer is on, the printer will turn off.
	Paper Feed Button	Paper output can be done manually by pressing this button. Additionally, self-testing and Hexadecimal Dumping can be processed.. 1. Refer to "3-10" for self test information. 2. Refer to the service manual regarding Hexadecimal Dumping.
	Battery Status Lamp	1. If the Batt, LED are Lit, the battery is fully charged. 2. If you can hear beeping sound and LED light is turned off, it means that the battery is at the lowest level. 3. If the battery is not charged at all, the printer turns off automatically.
	Error Lamp	If the red light is turned on, it means that the paper cover is open.

### 3-9. Self Test

You can check the printer setting state by doing self test when you set the printer first time or encounter some problems.

- Control Circuit, Mechanisms, Print Quality, Rom version.

When you can not find the exact cause of problem through self test, investigate on other hardware parts or software. This function is independent of other devices and software.

#### ● Self -Test Instructions

1. Turn the printer power off and close the printer paper cover.
2. While pressing the paper feed button, turn on the printer power.
3. The printout is producing
4. To add a printout of the Hex-Dump mode, press the paper feed button once more.





## 4-2. Interface Cable Connection

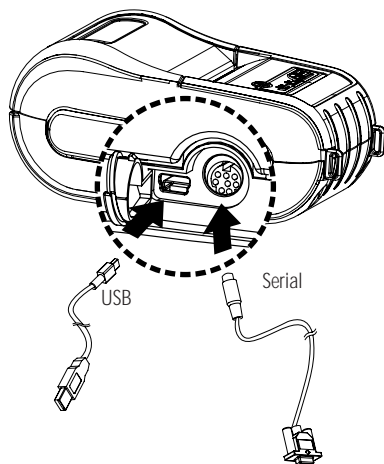

1. Connect the interface cable to the cable connector of the printer

**Notes:** Use only cables provided by this manufacturer

2. Connect the interface cable to the USB or Serial port of the device (PDA, PC, etc)

## 5. Printer cleaning

If the interior of the printer is dusty, printing quality can be lowered. In such a case, follow the instructions below to clean up the printer.

### NOTE

1. Make sure to turn the printer power off prior to cleaning
2. Regarding print head cleaning, as the print head sets very hot during printing, turn off the printer power and wait approximately 10 minute before commencement.
3. When cleaning the print head, take care not to touch the heated portion of the print head. The print head subject to be damaged by static electricity.
4. Take care not to allow the print head to become scratched and /or damaged in

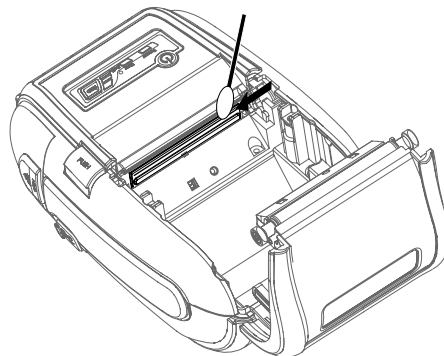

1. Use an applicator swab moistened with an alcohol solution to clean the print head and remove any dusts.
2. Once the cleaning is completed, insert paper roll into the printer few minutes later and close the printer cover.

## 6. Pritner Specification

### 6-1. Specification

Printing Method	Direct Thermal	
Printing Speed	80mm/sec	
Resolution	203 DPI X 203 DPI	
Character	ALPHA NUMERIC Character, Extension Character	
Barcode	Code 39, Code 93, UCC/EAN-128, Code 128, UPC-E, UPC-A, EAN-8, EAN-13, EAN-14, UPC and EAN 2 or 5 digit extensions, Plessey, FIM, Postnet, Interleaved 2-of-5, MSI, Codabar	
Emulation	CPCL	
Driver	Window CE 4.2&5.0, Window Mobile 5.0	
Sensor	Black-mark, Gap, cover open	
Paper	paper type	Thermal Paper
	width	58mm
	thickness	65 $\mu$ l
	External Diameter	Max. $\phi$ 56mm
	Internal Diameter	12.5mm +/-0.5mm
Reliability	TPH	100km
Communications	Serial(RS-232C), USB, Wireless Lan *802.11b/g	
Battery Charger	input	AC100~240V, 50/6 Hz
	output	8.4V , 1200 mA
Battery Charger	Battery type	Li-on
	output	7.2V, 2400mAh
	Charging time	2 Time
Size	WXDXH(mm)	104 X 74 X 154
	WXDXH"	4.0 X 2.9 X 6.0
Weight	500g	

Temperature	operation	5~40°C
	storage	-20~60°C
Humidity	operation	35 ~ 80%
	storage	10 ~ 90%

#### Federal Communication Commission Interference Statement

This equipment has been tested and found to comply with the limits for a Class B digital device, pursuant to Part 15 of the FCC Rules. These limits are designed to provide reasonable protection against harmful interference in a residential installation. This equipment generates, uses and can radiate radio frequency energy and, if not installed and used in accordance with the instructions, may cause harmful interference to radio communications. However, there is no guarantee that interference will not occur in a particular installation. If this equipment does cause harmful interference to radio or television reception, which can be determined by turning the equipment off and on, the user is encouraged to try to correct the interference by one of the following measures:

- Reorient or relocate the receiving antenna.
- Increase the separation between the equipment and receiver.
- Connect the equipment into an outlet on a circuit different from that to which the receiver is connected.
- Consult the dealer or an experienced radio/TV technician for help.

**FCC Caution:** To assure continued compliance, (example - use only shielded interface cables when connecting to computer or peripheral devices). Any changes or modifications not expressly approved by the party responsible for compliance could void the user's authority to operate this equipment. This device complies with Part 15 of the FCC Rules. Operation is subject to the following two conditions: (1) This device may not cause harmful interference, and (2) this device must accept any interference received, including interference that may cause undesired operation.

#### IMPORTANT NOTE:

##### FCC RF Radiation Exposure Statement:

This equipment complies with FCC RF radiation exposure limits set forth for an uncontrolled environment. This equipment should be installed and operated with a minimum distance of 20 centimeters between the radiator and your body. This transmitter must not be co-located or operating in conjunction with any other antenna or transmitter.

### IMPORTANT Safety Instruction:

#### CAUTION

To reduce the risk of electric shock, do not remove the top cover (or the rear section).  
No user serviceable parts inside, refer servicing to qualified personnel.



This symbol, wherever it appears, alerts you to the presence of uninsulated dangerous voltage inside the enclosure-voltage that may be sufficient to constitute a risk of shock.



This symbol, wherever it appears, alerts you to the important operating and maintenance instructions in the accompanying literature. Please read the manual.

- 1) Read these instructions.
- 2) Keep these instructions.
- 3) Heed all warnings.
- 4) Follow all instructions.
- 5) Do not use this equipment near water.
- 6) Do not use near any heat sources such as radiators, heat resistors, stove, or other equipment that produce heat.

**CAUTION**  
**RISK OF EXPLOSION IF BATTERY IS REPLACED**  
**BY AN INCORRECT TYPE.**  
**DISPOSE OF USED BATTERIES ACCORDING**  
**TO THE INSTRUCTIONS**

## European Union Regulatory Notice

Compliance with these directives implies conformity to harmonized European standards (European Norms) that are listed in the EU Declaration of Conformity issued by HP for this product or product family. This compliance is indicated by the following conformity marking placed on the product.



**The wireless telecommunications functionality of this product may be used in the following EU and EFTA countries:**

Austria, Belgium, Bulgaria, Cyprus, Czech Republic, Denmark, Estonia, Finland, France, Germany, Greece, Hungary, Iceland, Ireland, Italy, Latvia, Liechtenstein, Lithuania, Luxembourg, Malta, Netherlands, Norway, Poland, Portugal, Slovak Republic, Slovenia, Spain, Sweden, Switzerland, and United Kingdom.

#### Products with 2.4-GHz wireless LAN devices France

For 2.4 GHz Wireless LAN operation of this product certain restrictions apply:

This product may be used indoor for the entire 2400-2483.5 MHz frequency band (channels 1-13). For outdoor use, only 2400-2454 MHz frequency band (channels 1-9) may be used. For the latest requirements, see <http://www.art-telecom.fr>.

#### Italy :

License required for use. Verify with your dealer or directly with the General Direction for Frequency Planning and Management (Direzione Generale Pianificazione e Gestione Frequenze).

#### CE RF Radiation Exposure Statement:

**Caution** This equipment complies with European RF radiation exposure limits set forth for an uncontrolled environment. This equipment should be installed and operated with a minimum distance of 20 centimeters between the radiator and your body. This transmitter must not be co-located or operating in conjunction with any other antenna or transmitter.