



MODEL : LK-P20B

MOBILE PRINTER

All specifications are subject to change without notice



**RISK OF EXPLOSION IF BATTERY IS REPLACED BY AN INCORRECT TYPE.
DISPOSE OF USED BATTERIES ACCORDING TO THE INSTRUCTIONS**

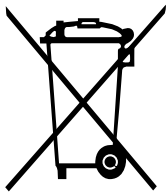

Disposal of Old Electrical & Electronic Equipment (Applicable in the European Union and other European countries with separate collection systems)

This symbol on the product or on its packaging indicates that this product shall not be treated as household waste.

Instead it shall be handed over to the applicable collection point for the recycling of electrical and electronics equipment. For more detailed information about recycling of this product, please contact your local city office, your household waste disposal service or the shop where you purchased the product.

Table of Contents

1. Product overview	3
2. Unpacking	4
3. Setting up the product	5
3-1. Installing battery	5
3-2. Charging the battery	6
3-3. Using the belt clip	7
3-4. Removing the battery	8
3-5. Loading the media	9
3-6. Verify the printer is working - Self test	10
4. Peripherals Connection	11
5. Setting up the software	12

1. Product overview

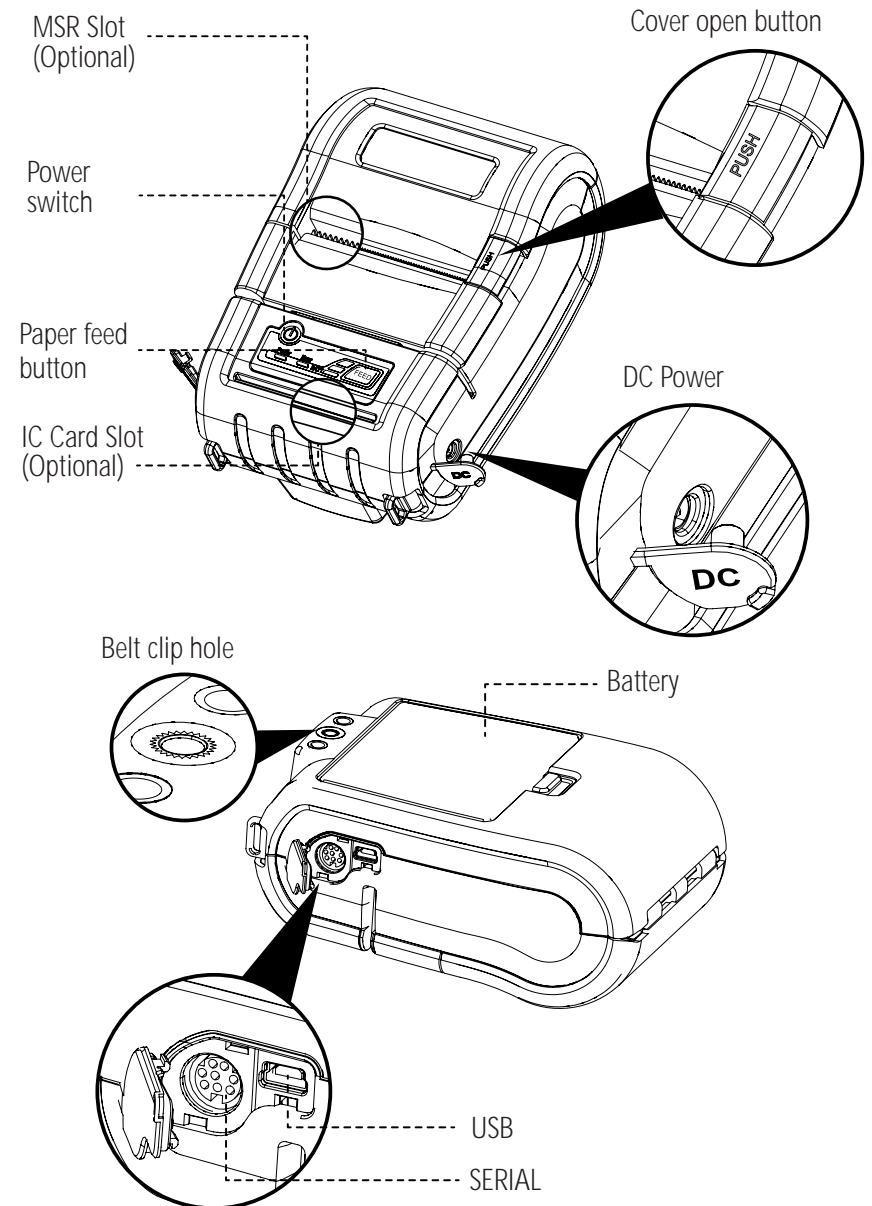

2. Unpacking

Standard

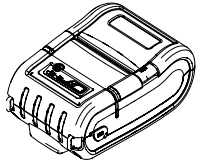

Printer

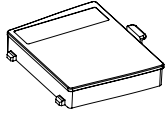

Battery

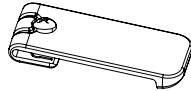

Belt Buckle

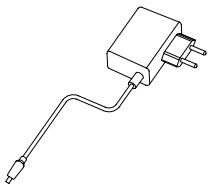

Recharger

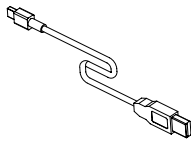

USB Shilded Cable

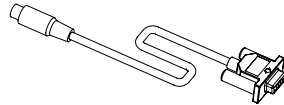

Serial Cable

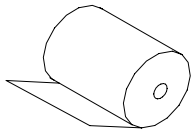

Roll paper

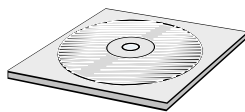

CD



Quick Manual

Option

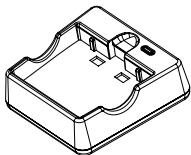

Battery recharger

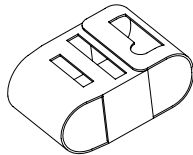

Printer case

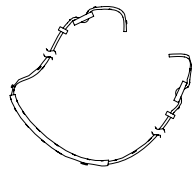

Strap

3. Setting Up the Product

3-1. Installing battery

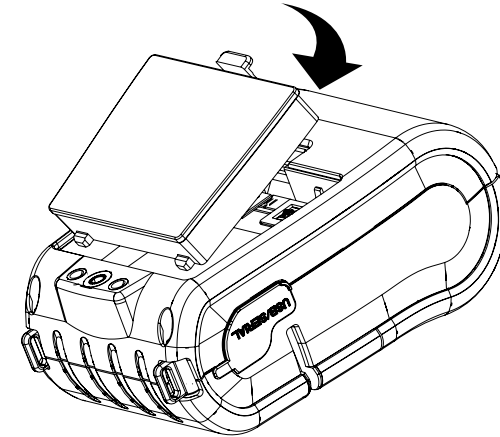

1. Align the battery hook as shown in the picture.
2. Push the battery into the printer until it locks in place.

Notes: The batteries are shipped uncharged.

Please see "Charging battery" to find out how to charge battery.

3-2. Charging battery

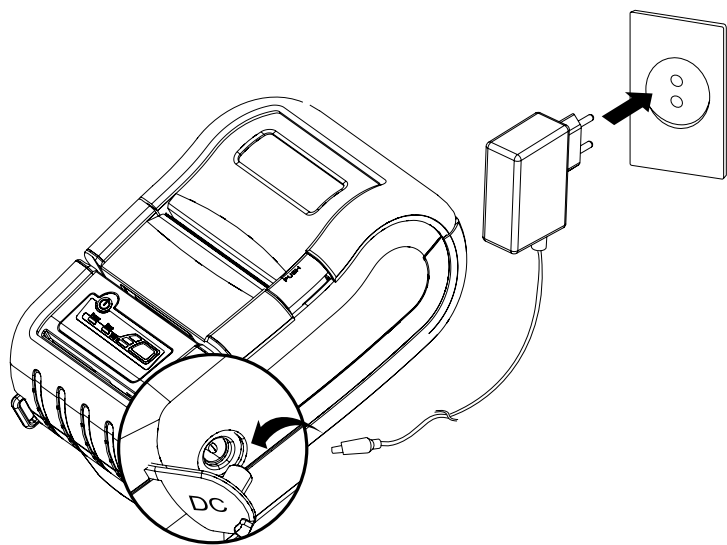

1. The battery can be charged only when the temperature is 0~40°C
2. Be sure that the printer is turn off and the battery to be charged is installed.
3. Connect the charger to the printer.
4. Recharging will now be started.

3-3. Using the belt clip

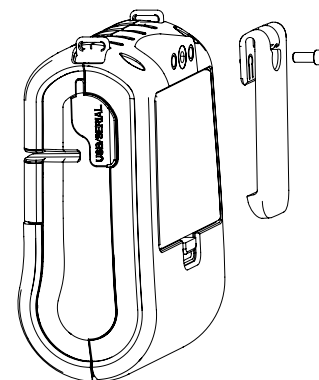

Insert screw into belt clip.

1
2

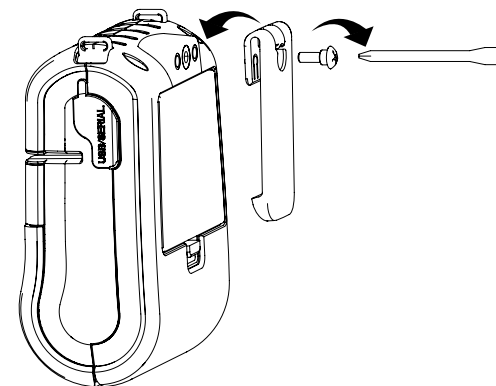

Tighten the screw with driver as shown.

3-4. Removing battery

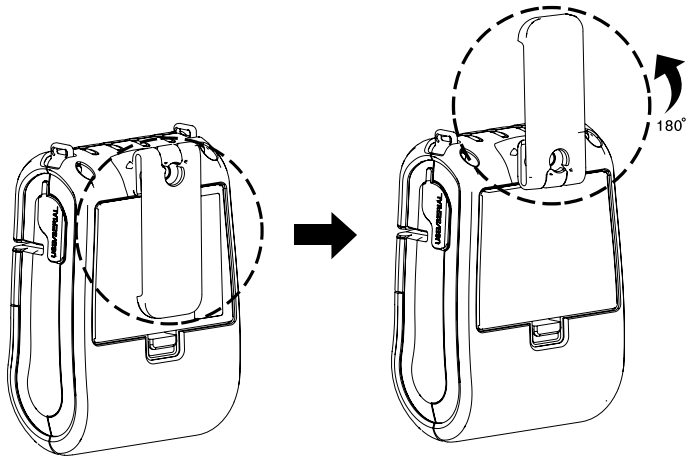

Rotate the belt clip as shown

1
2

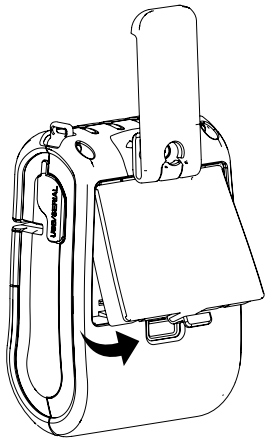

Remove the battery as shown

3-5. Loading the media.

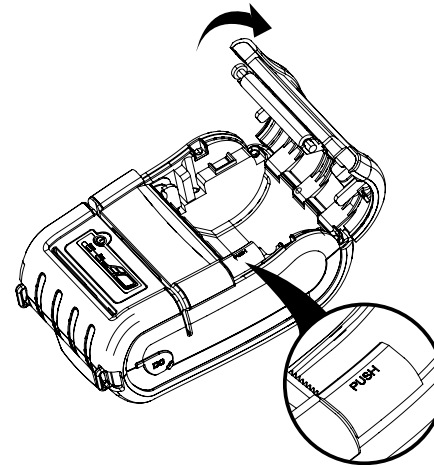

Press the cover open button and open

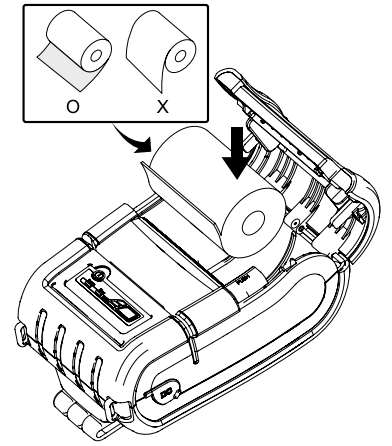

Place the paper roll as shown.
Make sure the paper is placed in
right direction.

1 2
3

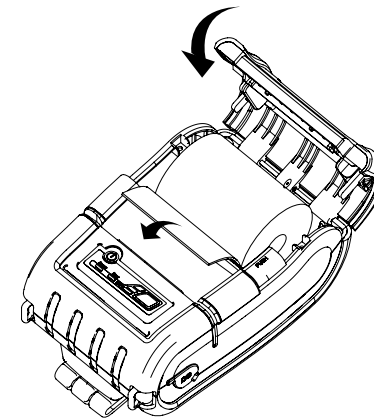

Pull a short length of paper out of
the printer and close the cover.

3-6. Verify the printer is working

How to do self-test

1. Turn the printer off.
2. Press and hold the feed button.
3. Press and release the power button and keep the feed button pressed.
4. When printing starts, release the feed button.

***** Completed *****

The printer is ready to receive data as soon as it completes the self-test.

4. Peripherals Connection

This product can communicate with other devices via Bluetooth communication and cable.

4-1. Bluetooth Connection

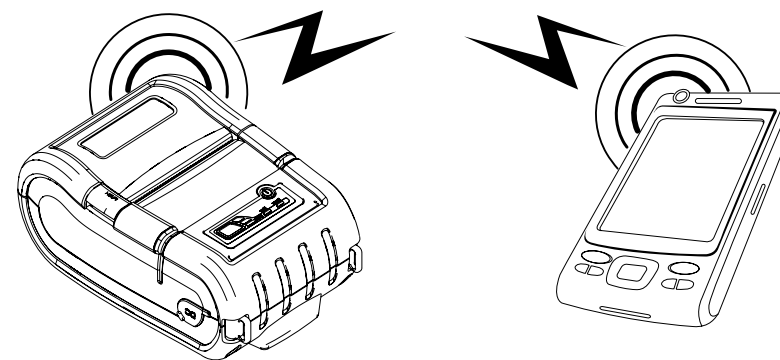

1. The Printer can be connected to devices equipped with Bluetooth communication capacity (PDAs, PCs, etc.)
2. Use the Bluetooth connection function supported by the device to connect to the printer.

Notes: Refer to the Bluetooth Manual for more details on connection.

5. Setting up the software

Please refer to the programming manual included in CD.

♣ Certification

FCC Information

This device complies with part 15 of the FCC Results. Operation is subject to the following two conditions:

- (1) This Device may not cause harmful interface, and
- (2) This device must accept any interference received, including interference that may cause undesired operation.

Note

This equipment has been tested and found to comply with the limits for CLASS B digital device, pursuant to Part 15 of FCC Rules. These limits are designed to provide reasonable protection against harmful interference when the equipment is operated in a commercial environment. This equipment generates, uses and can radiate radio frequency energy and, if not installed and used in accordance with the instructions, may cause harmful interference to radio communications. However, there is no guarantee that interference will not occur in a particular installation. If this equipment does cause harmful interference to radio or television reception, which can be determined by turning the equipment off and on, the user is encouraged to try correct the interference by one or more of the following measures:

- 1.1. Reorient or relocate the receiving antenna.
- 1.2. Increase the separation between the equipment and receiver.
- 1.3. Connect the equipment into an outlet on a circuit different from that to which receiver is connected.
- 1.4. Consult the dealer or experienced radio/TV technician for help.

⚠ WARNING

Changes or modifications not expressly approved by the manufacturer could void the user's authority to operate the equipment.

⚠ CAUTION: Exposure to Radio Frequency Radiation.

Antenna shall be mounted in such a manner to minimize the potential for human contact during normal operation. The antenna should not be contacted during operation to avoid the possibility of exceeding the FCC radio frequency exposure limit.



SEWOO TECH CO.,LTD.

ADDRESS Doosung Bd, 689-20, Kumjung-dong, Kunpo-si, Kyunggi-do, Korea
TEL 82-31-459-8200 FAX 82-31-459-8880
URL <http://www.miniprinter.com>