

Customer	Date	Document	Doc. Ver
SEWOO	2014.12.04	BnCOM Bluetooth SPP Module UART Protocol	1.0.0

SPP Module Manual

BnCOM(Blue and Communication)

AT communication protocol

For SPP module

OEM/Integrators Installation

BnCOM Co.,Ltd

[Http://www.bncomm.co.kr](http://www.bncomm.co.kr)

TEL)070-8274-8901

Customer SEWOO	Date 2014.12.04	Document BnCOM Bluetooth SPP Module UART Protocol	Doc. Ver 1.0.0
--------------------------	---------------------------	---	--------------------------

■ History

버전	배포일자	내역	작성자
1.0.0	2014.09.12	- First Release	JTY

Customer	Date	Document	Doc. Ver
SEWOO	2014.12.04	BnCOM Bluetooth SPP Module UART Protocol	1.0.0

INDEX

1. OVERVIEW	5
1.1. PROTOCOL BASIC RULE	8
2. REQUEST (HOST→BT) PROTOCOL SUMMARY.....	10
3. NOTIFY (BT→HOST) PROTOCOL SUMMARY	11
4. GENERAL RESPONSE (BT→HOST) PROTOCOL SUMMARY	11
5. REQUEST PROTOCOL DETAIL.....	12
5.1. AT↵.....	12
5.2. ATZ↵	12
5.3. AT&F↵	12
5.4. AT+CONNECT↵.....	13
5.5. AT+DATA=N,XXXXX↵	13
5.6. AT+SETSLEEP=N ↵	13
5.7. AT+SETSCAN=N,T0↵	13
5.8. AT+SETAUTOCON=E,N,T↵	14
5.9. AT+SETSSP=N↵	14
5.10. AT+SETINITMODE=N↵	14
5.11. AT+SETPIN=XXXX↵.....	14
5.12. AT+SETLP=E↵.....	15
5.13. AT+SETNAME=XXXX↵	15
5.14. AT+SETUART=B,P,S↵	15
5.15. AT+CONNECTMAC=XXXX↵	15
5.16. AT+SETROS=N↵	16
5.17. AT+SETMODEL=XXXX ↵	16
5.18. AT+SETPROSTR=XXXX ↵	16
5.19. AT+SETSERIAL=XXXX↵	16
5.20. AT+SETMANUF=XXXX↵.....	16
5.21. AT+SETDEVCLASS=N,V↵	17
5.22. AT+GETCP↵.....	17
5.23. AT+SETLED=N↵	17

Customer	Date	Document	Doc. Ver
SEWOO	2014.12.04	BnCOM Bluetooth SPP Module UART Protocol	1.0.0

5.24. AT+GETINFO=N^d 17

Customer	Date	Document	Doc. Ver
SEWOO	2014.12.04	BnCOM Bluetooth SPP Module UART Protocol	1.0.0

1. overview

- Product : SBT-B1 (with BCM-D408EF2 bluetooth module)
- Frequency : 2.
- Bluetooth version : 2.1+EDR
- Operation temp. : MAX -30 ~ 85
- Supply voltage range : 2.7V ~ 3.6V

- Block Diagram

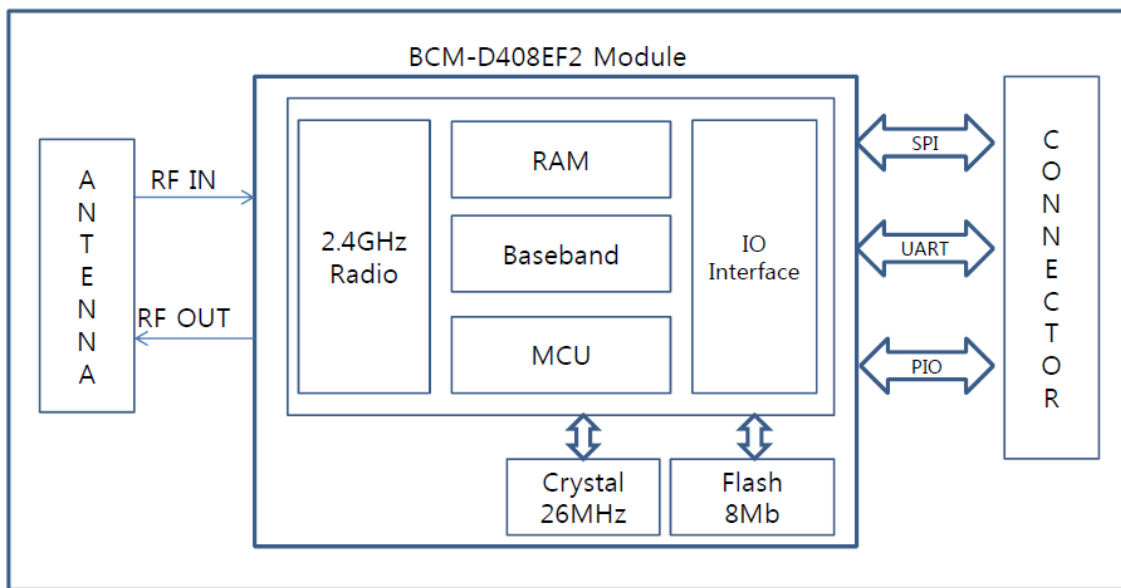

Figure 1 SBT-B1

This module has been granted modular approval for mobile applications. OEM integrators for host products may use the module in their final products without additional FCC / IC (Industry Canada) certification if they meet the following conditions. Otherwise, additional FCC / IC approvals must be obtained.

- The host product with the module installed must be evaluated for simultaneous transmission requirements.
- The users manual for the host product must clearly indicate the operating requirements and conditions that must be observed to ensure compliance with current FCC / IC RF exposure guidelines.
- To comply with FCC / IC regulations limiting both maximum RF output power and human exposure to RF radiation, use this module only with the included onboard antenna.

Customer	Date	Document	Doc. Ver
SEWOO	2014.12.04	BnCOM Bluetooth SPP Module UART Protocol	1.0.0

- A label must be affixed to the outside of the host product with the following statements.

This device contains FCCID: **WF5SBTB1**

This equipment contains equipment certified under ICID: **9080A-SBTB1**

The final host / module combination may also need to be evaluated against the FCC Part 15B criteria for unintentional radiators in order to be properly authorized for operation as a Part 15 digital device.

This transmitter module has been certified for FCC Part 15 operation; when installed in a host device, the host manufacturer is responsible for making sure that the host device with the transmitter installed continues to be compliant with Part 15B unintentional radiator requirements.

This device complies with Part 15 of the FCC Rules and Industry Canada License-exempt RSS standard(s).

Operation is subject to the following two conditions:

- (1) This device may not cause harmful interference, and
- (2) This device must accept any interference received, including interference that may cause undesired operation of the device.

Caution Statement for Modifications:

CAUTION: Changes or modifications not expressly approved by the manufacturer could void the user's authority to operate the equipment.

- This device complies with part 15 of the FCC Rules and Industry Canada License-exempt RSS standard(s). Operation is subject to the following two conditions: (1) This device may not cause harmful interference, and (2) this device must accept any interference received, including interference that may cause undesired operation.
- Le présent appareil est conforme aux CNR d'Industrie Canada applicables aux appareils radio exempts de licence. L'exploitation est autorisée aux deux conditions suivantes : (1) l'appareil ne doit pas produire de brouillage, et (2) l'utilisateur de l'appareil doit accepter tout brouillage radioélectrique subi, même si le brouillage est susceptible d'en compromettre le fonctionnement.

- Any changes or modifications not expressly approved by the party responsible for

Customer	Date	Document	Doc. Ver
SEWOO	2014.12.04	BnCOM Bluetooth SPP Module UART Protocol	1.0.0

compliance could void the user's authority to operate the equipment.

- Labeling

- FCC ID: WF5SBTB1 / IC : 9080A-SBTB1

The certification label of a module shall be clearly visible at all times when installed in the host device.

A label must be affixed to the outside of the host product with the following statements:

"Contains FCC ID: WF5SBTB1"

"Contains IC: 9080A-SBTB1"

- Caution: Exposure to Radio Frequency Radiation.

To comply with RF exposure compliance requirements, a separation distance of at least 20 cm must be maintained between the antenna of this device and all persons.

*The module is limited to OEM installation only.

OEM integrators must ensure that the end-user has no manual instructions to remove or install the module. OEM's must comply with FCC marking regulation part 15 declaration of conformity (Section 2.925(e)).

This module is to be installed only in mobile or fixed applications (Please refer to FCC CFR 47 Part 2.1091(b) for a definition of mobile and fixed devices).

The separate approval is required for all operating configurations, including portable configurations with respect to FCC CFR 47 Part 2.1093 and different antenna configurations.

The SBT-B1 Module has been designed to operate with the following antenna and gains. Use with other antenna types or with these antenna types at higher gains is strictly prohibited.

Manufacturer	Type of Antenna	Model	Gain (dB)	Type of Connector
AMOTECH Co., Ltd.	Chip Antenna	AMAN802012MS02	3.14	Permanent integral

Customer SEWOO	Date 2014.12.04	Document BnCOM Bluetooth SPP Module UART Protocol	Doc. Ver 1.0.0
--------------------------	---------------------------	---	--------------------------

1.1. Protocol Basic Rule

- HOST and BT transfer is base from UART(serial port) interface.
- UART(serial port) default setting value
 - Baud rate : 230400bps
 - Data bit : 8
 - Parity bit : none
 - Stop bit : 1
- Communication direction
 - REQUEST (HOST→BT): From HOST to BT
 - NOTIFY(BT → HOST) : From BT to HOST. Notify BT Status
 - RESPONSE(BT → HOST) : From BT to HOST.
- Communication rule
 - Almost Protocol is combind to ascii. Also It is notify end of command packet attach carriage return(0x0D,↵)

Ex) REQUEST – Recently Connected Device : AT+CONNECT

Command	AT+CONNECT										
Command set	A	T	+	C	O	N	N	E	C	T	↵
Ascii set	0x41	0x54	0x2B	0x43	0x4F	0x4E	0x4E	0x45	0x43	0x54	0x0D

Ex) NOTIFY – iAP Support / BT Initial mode : +StartL

Command									
command set	+	S	t	a	r	t	L	↵	
ascii set	0x2B	0x53	0x54	0x41	0x52	0x54	0x4C	0x0D	

Ex) RESPONSE – REQUEST fail : +ERROR<1>

Command	+ERROR<1>									
command set	+	E	R	R	O	R	<	1	>	↵
ascii set	0x2B	0x45	0x52	0x52	0x4F	0x52	0x3C	0x31	0x3E	0x0D

Customer	Date	Document	Doc. Ver
SEWOO	2014.12.04	BnCOM Bluetooth SPP Module UART Protocol	1.0.0

Customer	Date	Document	Doc. Ver
SEWOO	2014.12.04	BnCOM Bluetooth SPP Module UART Protocol	1.0.0

2. REQUEST (HOST→BT) Protocol Summary

프로토콜	설명	비고
AT	UART Tx, Rx path Test	
ATZ	BT reset	
AT&F	BT factory reset	
AT+CONNECT	Last connected device reconnection	
AT+SETSCAN=n,t0	scan mode setting : n=0 – Unuse discoverable and page scan : n=1 – Available discoverable : n=2 – Available page scan : n=3 – Available discoverable and page scan : t0 – (0~180sec)	
AT+DATA=n,xxxx	In IAP mode, when send data to iOS device N : Transmit data length (Max 140 bytes) XXXX : Transmit Data	Only Local IAP Mode
AT+SETSLEEP=n	DeepSleep mode enable / disable	
AT+SETAUTOCON=e,n,t	BT에서 remote device auto connection : e – Auto connection setting (0 or 1) : n – Auto connection retry number (1~50회) : t – Auto connection retry period time (1 ~ 180sec)	
AT+SETINITMODE=n	BT Connection mode setting : n=1 – After power on, stay connectable : n=2 – After power on, stay discoverable and connectable : n=3 – After power on, auto connection to last connected device	
AT+SETPIN=xxxx	PIN code setting : xxxx – PIN Number (4~16 character)	
AT+SETLP=e	Low power mode enable / disable : e – low power mode (0 or 1)	
AT+SETNAME=xxxx	Changed local name of device : xxxx –name string(1~30character)	
AT+SETUART=b,p,s	HOST UART Setting : b – Baudrate(1200, 2400, 4800, 9600, 19200, 38400,	

Customer SEWOO	Date 2014.12.04	Document BnCOM Bluetooth SPP Module UART Protocol	Doc. Ver 1.0.0
--------------------------	---------------------------	---	--------------------------

	57600, 115200, 230400 or 460800) : p – Parity bit(N,E or O) : s – Stop bit (1 or 2)	
AT+CONNECTMAC=xxxx	Connect to remote device with Bluetooth specific address : xxxx –remote device Bluetooth address(12character)	
AT+SETLED=n	LED enable or disable. Apply after rebooting. (0: disable , 1 : enable)	
AT+SETDEVCLASS=n,v	Device of class setting N : 0 (Un-store class), 1(stored) V : 'P' (Printer Class), 'H' (Headset Class)	
AT+GETCP	Identify CP chip available	
AT+GETINFO=n	BT Status : n – Status or information index (0~17)	

3. NOTIFY (BT→HOST) Protocol Summary

프로토콜	설명	비고
+Starth	Normal boot mode	
+StartL	Local iAP boot mode	
+StartF	Local iAP boot fail mode	
+SUCCESS	Success send data to iOS device	
+FAILn	Fail send data to iOS device	n : 1 ~5

4. General RESPONSE (BT→HOST) Protocol Summary

프로토콜	설명	비고
+OK	REQUEST Successfully	
+ERROR<N>	REQUEST Error	N =1 : BAD_HOST_COMMAND, N =2 : BAD_HOST_COMMAND_LENGTH, N =3 : BAD_HOST_COMMAND_PARAMETER, N =4 : BAD_LOCAL_STATE, N =5 : NOT_MATCHED_OR_NO_DATA, N =6 : UNHANDLED_REMOTE_RESPONSE,

Customer	Date	Document	Doc. Ver
SEWOO	2014.12.04	BnCOM Bluetooth SPP Module UART Protocol	1.0.0

		N =7 : FAIL_OR_BAD_REMOTE_RESPONSE, N =8 : UNKNOWN_ERROR
--	--	---

5. REQUEST Protocol Detail

5.1. AT↵

Action	HOST and BT check uart
Response	+OK↵ or +ERROR<N>↵
example	(HOST→BT) : AT ↵ (BT→HOST) : +OK↵

5.2. ATZ↵

Action	BT Soft Reset
Response	+OK↵ or +ERROR<N>↵
example	(HOST→BT) : ATZ ↵ (BT→HOST) : +OK↵ BT reset and rebooting

5.3. AT&F↵

Action	Factory Reset
Response	+OK↵ or +ERROR<N>↵
example	- . iAP Mode : iAP Local - . Sniff Mode : Enable - . Auto Connection : Enable - . Init Mode : Discoverable Mode - . Uart Setting : 230400 bps / Parity None / 1 stop bits - . Pin code : 0000 - . iAP Manufacturer : BnCOM - . iAP Model Name : BCM-D408EF2 - . iAP Device Name : Mobile Printer - . iAP Protocol String : com.mobileprinter.datapath
	(HOST→BT) : AT&F ↵

Customer	Date	Document	Doc. Ver
SEWOO	2014.12.04	BnCOM Bluetooth SPP Module UART Protocol	1.0.0

	(BT→HOST) : +OK↵
--	------------------

5.4. AT+CONNECT↵

Action	Try connection to Remote device
Response	+OK↵ or +ERROR<N>↵
example	(HOST→BT) : AT+CONNECT ↵ (BT→HOST) : +OK↵

5.5. AT+DATA=n,xxxxx↵

Action	Data send to Remote iOS device
Response	+SUCCESS, or +FAIL<n>
example	(HOST→BT) : AT+DATA=5,12345 (BT→HOST) : +SUCCESS↵ or +FAIL<n>

5.6. AT+SETSLEEP=n↵

Action	Sleep setting
Response	+OK or +ERROR<n>
example	(HOST→BT) : AT+SETSLEEP=0 (disable) (BT→HOST) : +OK↵ or +ERROR<n>

5.7. AT+SETSCAN=n,t0↵

Action	Discoverable and paging scan setting
Response	+OK↵ or +ERROR<N>↵
example	n = 0 Non discoverable and paging scan n = 1 discoverable. n=2 page scan n=3 discoverable and page scan

Customer	Date	Document	Doc. Ver
SEWOO	2014.12.04	BnCOM Bluetooth SPP Module UART Protocol	1.0.0

	.
	(HOST→BT) : AT+SETSCAN=3,0 ↵ (BT→HOST) : +OK↵

5.8. AT+SETAUTOCON=e,n,t↵

Action	Auto connection configuration
Response	+OK↵ or +ERROR<N>↵
example	(HOST→BT) : AT+SETAUTOCON=1,20,5 ↵ (BT→HOST) : +OK↵

5.9. AT+SETSSP=n↵

Action	Pairing Mode setting
Response	+OK↵ or +ERROR<N>↵
example	(HOST→BT) : AT+SETSSP=0 ↵ (BT→HOST) : +OK↵ (BT→HOST) : +Start<x>↵

5.10. AT+SETINITMODE=n↵

Action	BT connection mode setting
Response	+OK↵ or +ERROR<N>↵
example	(HOST→BT) : AT+SETINITMODE=2 ↵ (BT→HOST) : +OK↵ (BT→HOST) : +START↵

5.11. AT+SETPIN=xxxx↵

Action	BT pin code setting
Response	+OK↵ or +ERROR<N>↵
example	
	(HOST→BT) : AT+SETPIN=1234 ↵

Customer	Date	Document	Doc. Ver
SEWOO	2014.12.04	BnCOM Bluetooth SPP Module UART Protocol	1.0.0

	(BT→HOST) : +OK↵
--	------------------

5.12. AT+SETLP=e↵

Action	Remote device low power mode setting
Response	+OK↵ or +ERROR<N>↵
example	(HOST→BT) : AT+SETLP=1 ↵ (BT→HOST) : +OK↵

5.13. AT+SETNAME=xxxx↵

Action	BT local name changed
Response	+OK↵ or +ERROR<N>↵
example	(HOST→BT) : AT+SETNAME=BnCOM DEMO SPP ↵ (BT→HOST) : +OK↵

5.14. AT+SETUART=b,p,s↵

Action	UART configuration
Response	+OK↵ or +ERROR<N>↵
example	(HOST→BT) : AT+SETUART=115200,N,1 ↵ (BT→HOST) : +OK↵

5.15. AT+CONNECTMAC=xxxx↵

Action	BT Connection.
Response	+OK↵ or +ERROR<N>↵
example	
	(HOST→BT) : AT+CONNECT=74f07db00001 ↵ (BT→HOST) : +OK↵

Customer	Date	Document	Doc. Ver
SEWOO	2014.12.04	BnCOM Bluetooth SPP Module UART Protocol	1.0.0

5.16. AT+SETROS=*n*

Action	BT OS Type Setting
Response	+OK or +ERROR<N>
example	(HOST→BT) : AT+SETROS=0 (BT→HOST) : +OK

5.17. AT+SETMODEL=*xxxx*

Action	HOST model name setting to BT
Response	+OK or +ERROR<N>
example	(HOST→BT) : AT+SETMODEL=BnCOM_DEMO_SPP (BT→HOST) : +OK

5.18. AT+SETPROSTR=*xxxx*

Action	protocol string setting
Response	+OK or +ERROR<N>
example	(HOST→BT) : AT+SETPROSTR=com.bncom.protocol (BT→HOST) : +OK

5.19. AT+SETSERIAL=*xxxx*

Action	Serial number Setting
Response	+OK or +ERROR<N>
example	(HOST→BT) : AT+SETSERIAL=123456789 (BT→HOST) : +OK

5.20. AT+SETMANUF=*xxxx*

Action	HOST manufacturer information setting
Response	+OK or +ERROR<N>
example	(HOST→BT) : AT+SETMANUF=BnCOM

Customer	Date	Document	Doc. Ver
SEWOO	2014.12.04	BnCOM Bluetooth SPP Module UART Protocol	1.0.0

	(BT→HOST) : +OK↵
--	------------------

5.21. AT+SETDEVCLASS=n,v↵

Action	BT Module Device of Class setting
Response	+OK↵ or +ERROR<N>↵
example	(HOST→BT) : AT+SETDEVCLASS=1,P ↵ (BT→HOST) : +OK↵ or +FAIL<n>

5.22. AT+GETCP↵

Action	Identify CP Chip
Response	+OK↵ or +FAIL<N>↵
example	(HOST→BT) : AT+GETCP ↵ (BT→HOST) : +OK↵ or +FAIL

5.23. AT+SETLED=n↵

Action	LED Configuration
Response	+OK↵ or +FAIL<N>↵
example	(HOST→BT) : AT+SETLED=1 ↵ (Enable) (BT→HOST) : +OK↵ or +FAIL

5.24. AT+GETINFO=n↵

Action	BT Status Configuration
Response	n=0 : +<BT name>↵ n=1 : +<BT address>↵ n=2 : +<Remote device name>↵ n=3 : +<Remote device address>↵ n=4 : +<Init Mode>↵ n=5 : +<Uart Setting>↵

Customer	Date	Document	Doc. Ver
SEWOO	2014.12.04	BnCOM Bluetooth SPP Module UART Protocol	1.0.0

	<p>n=6 : +<PinCode >↵</p> <p>n=7 : +<Power Save mode setting>↵</p> <p>n=8 : +<Supervision Time>↵</p> <p>n=9 : +<Automatically Connection>↵</p> <p>n=10 : +<Hardware Version>↵</p> <p>n=11 : +<BT firmware version>↵</p> <p>n=12 : +<SSP or Legacy Mode></p> <p>n=13 : +<Manufacturer>↵</p> <p>n=14 : +<Model Number>↵</p> <p>n=15 : +<Protocol String>↵</p> <p>n=16 : +<Serial Number>↵</p> <p>n=17: +<IAP or SPP></p> <p>n=18: +EN<x>,CLASS<x></p> <p>n=19: +LED<x></p>
example	<p>(HOST→BT) : AT+GETINFO=n↵</p> <p>n=0 : (BT→HOST) : +BnCOM DEMO SPP</p> <p>n=1 : (BT→HOST) : +LOCALBD<74f07db00001></p> <p>n=2 : (BT→HOST) : +BnCOM Remote Device</p> <p>n=3 : (BT→HOST) : +REMOTEBD<74f07db00002></p> <p>n=4 : (BT→HOST) : +INITMODE<2></p> <p>n=5 : (BT→HOST) : +UART<115200,0,0></p> <p>n=6 : (BT→HOST) : +0000</p> <p>n=7 : (BT→HOST) : +PS<0></p> <p>n=8 : (BT→HOST) : +ST<2></p> <p>n=9 : (BT→HOST) : +AUTOCON<1,5,10></p> <p>n=10 : (BT→HOST) : +HWVER<1.0.0></p> <p>n=11 : (BT→HOST) : +SWVER<1.0.0></p> <p>n=12 : (BT→HOST) : +SSP or +LEGACY</p> <p>n=13 : (BT→HOST) : +MANU<BnCOM></p> <p>n=14 : (BT→HOST) : +MODEL<BnCOM Demo SPP></p> <p>n=15 : (BT→HOST) : +PROS<com.bncom.protocol></p> <p>n=16 : (BT→HOST) : +SER<000000000000></p> <p>n=17 : (BT->HOST) : +IAP or +SPP</p> <p>n=18 : (BT->HOST) : +EN<0>,CLASS<H></p>

Customer	Date	Document	Doc. Ver
SEWOO	2014.12.04	BnCOM Bluetooth SPP Module UART Protocol	1.0.0

	n=19 : (BT->HOST) : +LED<0>
--	-----------------------------