

SURFboard™ SB6190

DOCSIS® 3.0 Cable Modem



Quick Start Guide

In the Box

- SB6190 Cable Modem
- Power Supply
- Ethernet Cable
- Software License & Warranty Card
- Support Information Card
- SB6190 Quick Start Guide

IMPORTANT!

You must have a live broadband cable connection already installed in your home before installing the SB6190 Cable Modem. If you do not, please contact a service provider for assistance.

When contacting a service provider, you may have to provide the **MAC address** and **Serial number** listed on the cable modem label on the bottom of your SB6190 (see back page).

Install the Cable Modem

1. Check that a coaxial cable is already connected to a cable wall outlet and then connect the other end of the coaxial cable to the **Cable** connector on the rear of your SB6190.
Use your hand to tighten the connectors to avoid damaging them.
2. Connect the Ethernet cable to the **Ethernet** port on your computer and to the **Ethernet** port on the rear of your SB6190.
3. Connect the power cord to the **Power** port on the rear of your SB6190 and then plug the other end into an electrical wall outlet that is not controlled by a wall switch.

This automatically powers ON your SB6190.

Test the Cable Modem Connection

1. Power ON your computer. The **Receive**, **Send**, and **Online** LEDs on your SB6190 will first FLASH (blink) and then light up SOLID.

Check the Front Panel LED Status table for more information (see back page).

Note: If all three LEDs did not light up SOLID, contact your service provider.

2. Open any web browser on your computer, such as Internet Explorer, Google Chrome, Firefox, or Safari.
3. Type a valid URL (such as **www.surfboard.com**) in the address bar and press **Enter** to test your network connection. The ARRIS website should open.

- If the website opens, your SB6190 was set up properly.
- If the website fails to open, first check each cable connection on your devices to ensure that they are securely connected. Then, retype the URL.
If still unsuccessful, contact your current service provider to either set up your Internet service or activate your SB6190.

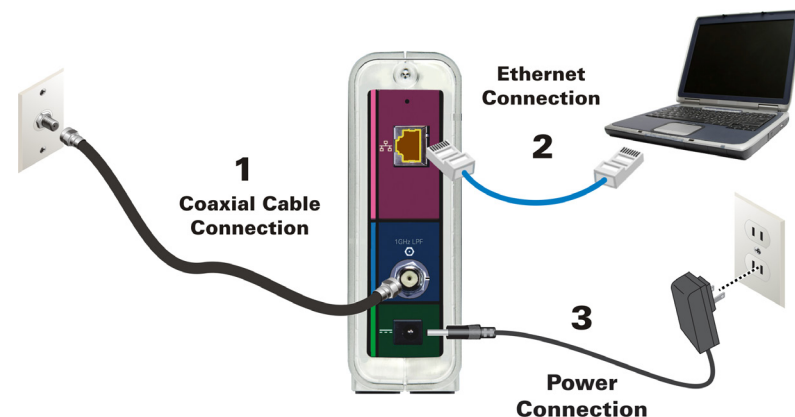

BEFORE RETURNING THIS PRODUCT TO THE STORE for any reason, please call ARRIS Technical Support: **1-877-466-8646**

Please visit www.arris.com/consumer for frequently asked questions (FAQs) and additional product documentation.

For Comcast subscribers only, please visit www.comcast.com/activate before calling Comcast or ARRIS.

SURFboard™ SB6190

DOCSIS® 3.0 Cable Modem



Quick Start Guide

Front Panel LEDs



During normal operation, the **POWER, RECEIVE, SEND, and ONLINE** LEDs should always be lit **SOLID** green or blue.

***Note:** During startup, all four LEDs will FLASH and then light up SOLID in sequence. If an LED turns ON and the next LED does not FLASH, please contact your service provider for assistance.*

Cable Modem Label



Please note: The cable modem label is also located on the bottom of your SB6190. The label contains specific ID information for your SB6190 that you may need when contacting your service provider.

To receive high-speed Internet service, your service provider may request the Media Access Control (MAC) address (see **HFC MAC ID**) and Serial number (see **S/N**) listed on the cable modem label.

ICON	LED STATUS
	Green (ON): Indicates power to the SB6190 is properly connected
	Green (ON): Indicates a downstream (receive data) channel connection Blue* (ON): Indicates a bonded downstream (receive data) channel connection
	Green (ON): Indicates an upstream (send data) channel connection Blue* (ON): Indicates a bonded upstream (send data) channel connection
	Green (ON): Indicates Internet connectivity

*DOCSIS 3.0 operation (high-speed Internet access) may not be available in all locations. Check with your service provider for more information.

© 2015 ARRIS Enterprises, Inc. All rights reserved.

No part of the contents of this publication may be reproduced or transmitted in any form or by any means without written permission from ARRIS Enterprises, Inc.

ARRIS, SURFboard, and the ARRIS logo are all trademarks or registered trademarks of ARRIS Enterprises, Inc. Other trademarks and trade names may be used in this document to refer to either the entities claiming the marks and the names of their products. ARRIS disclaims proprietary interest in the marks and names of others.

All other product or service names are the property of their respective owners. No part of the contents of this document may be reproduced or transmitted in any form or by any means without the written permission of the publisher.

ARSVD01621-b 12/2015

