

# AKAI

## Candy House - Sing-along with Bluetooth Music

INSTRUCTION MANUAL

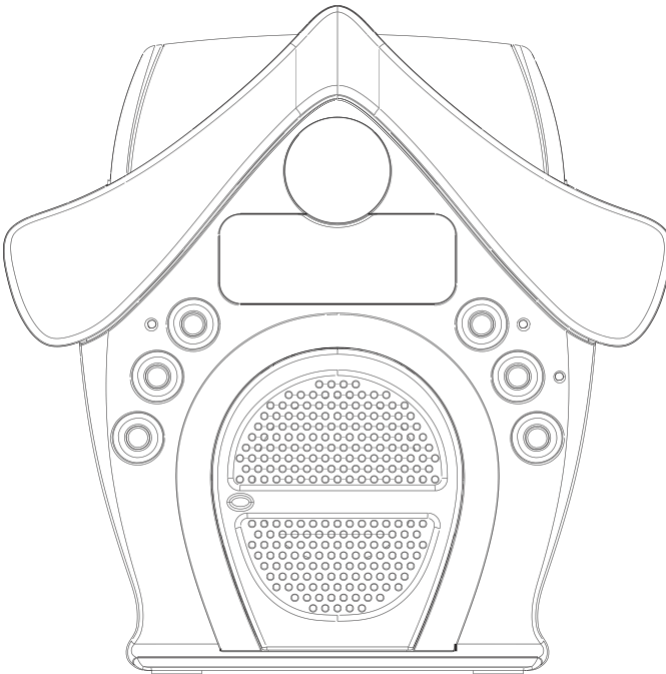



**SMK470**

Thank you for purchasing this Singalong. Please read this instruction manual carefully before using this product to ensure proper use. Keep this manual in a safe place for future reference.

# WARNINGS

---

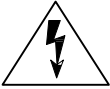
**WARNING:** TO REDUCE THE RISK OF FIRE OR SHOCK HAZARD, DO NOT EXPOSE THIS PRODUCT TO RAIN OR MOISTURE.

	<b>CAUTION</b> RISK OF ELECTRIC SHOCK DO NOT OPEN	
<b>CAUTION:</b> TO PREVENT THE RISK OF ELECTRIC SHOCK, DO NOT REMOVE COVER OR BACK. NO USER-SERVICEABLE PARTS INSIDE. REFER SERVICING TO QUALIFIED PERSONNEL.		

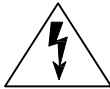

This symbol is intended to alert you to the presence of uninsulated dangerous voltage within the product's enclosure that might be of sufficient magnitude to constitute a risk of electric shock. Do not open the product's case.



This symbol is intended to inform you that important operating and maintenance instructions are included in the literature accompanying this product.

## DRIPPING WARNING

The product shall not be exposed to dripping or splashing and that no objects filled with liquids, such as vases, shall be placed on the product.

## VENTILATION WARNING

The normal ventilation of the product shall not be impeded for intended use.

Class II equipment symbol



This symbol indicates that the power adaptor has a double insulation system.

# FCC AND CANADIAN ICES

---

## IC Caution.

RSS-Gen Issue 4 November 2014" & "CNR-Gen 4e édition November 2014:

- English:

This device complies with Industry Canada licence-exempt RSS standard(s).

Operation is subject to the following two conditions: (1) This device may not cause interference, and (2) This device must accept any interference, including interference that may cause undesired operation of the device.

- French:

Le présent appareil est conforme aux CNR d'Industrie Canada applicables aux appareils radio exempts de licence. L'exploitation est autorisée aux deux conditions suivantes:

(1) l'appareil ne doit pas produire de brouillage, et

(2) l'utilisateur de l'appareil doit accepter tout brouillage radioélectrique subi, même si le brouillage est susceptible d'en compromettre le fonctionnement.

Le dispositif a été évalué pour répondre aux exigences générales d'exposition aux radiofréquences.

L'appareil peut être utilisé dans un état d'exposition portable sans restriction.

## FCC Caution.

This equipment has been tested and found to comply with the limits for a Class B digital device, pursuant to part 15 of the FCC Rules. These limits are designed to provide reasonable protection against harmful interference in a residential installation. This equipment generates, uses and can radiate radio frequency energy and, if not installed and used in accordance with the instructions, may cause harmful interference to radio communications. However, there is no guarantee that interference will not occur in a particular installation. If this equipment does cause harmful interference to radio or television reception, which can be determined by turning the equipment off and on, the user is encouraged to try to correct the interference by one or more of the following measures:

- Reorient or relocate the receiving antenna.
- Increase the separation between the equipment and receiver.
- Connect the equipment into an outlet on a circuit different from that to which the receiver is connected.
- Consult the dealer or an experienced radio/TV technician for help.

Caution: Any changes or modifications to this device not explicitly approved by manufacturer could void your authority to operate this equipment.

This device complies with part 15 of the FCC Rules. Operation is subject to the following two conditions: (1) This device may not cause harmful interference, and (2) this device must accept any interference received, including interference that may cause undesired operation.

The device has been evaluated to meet general RF exposure requirement. The device can be used in portable exposure condition without restriction.

# FCC AND CANADIAN ICES

## IMPORTANT SAFETY INSTRUCTIONS

1. Read these Instructions.
2. Keep these Instructions.
3. Heed all Warnings.
4. Follow all instructions.
5. Do not use this apparatus near water.
6. Clean only with a dry cloth.
7. Do not block any of the ventilation openings. Install in accordance with the manufacturers instructions.
8. Do not install near any heat sources such as radiators, heat registers, stoves, or other apparatus (including amplifiers) that produce heat.
9. Do not defeat the safety purpose of the polarized or grounding - type plug. A polarized plug has two blades with one wider than the other. A grounding type plug has two blades and a third grounding prong. The wide blade or the third prong are provided for your safety. When the provided plug does not fit into your outlet, consult an electrician for replacement of the obsolete outlet.
10. Protect the power cord from being walked on or pinched particularly at plugs, convenience receptacles, and the point where they exit from the apparatus.
11. Only use attachments/accessories specified by the manufacturer.
12. Use only with a cart, stand, tripod, bracket, or table specified by the manufacturer, or sold with the apparatus. When a cart is used, use caution when moving the cart/apparatus combination to avoid



injury from tip-over.





### Portable Cart Warning

13. Unplug this apparatus during lightning storms or when unused for long periods of time.
14. Refer all servicing to qualified service personnel. Servicing is required when the apparatus has been damaged in any way, such as power-supply cord or plug is damaged, liquid has been spilled or objects have fallen into the apparatus, the apparatus has been exposed to rain or moisture, does not operate normally, or has been dropped.

# IMPORTANT SAFETY INSTRUCTIONS

## WARNINGS:

- To reduce the risk of fire or electric shock, do not expose this apparatus to rain or moisture. Avertissement: pour réduire le risque d'incendie ou de choc électrique, ne pas exposer cet appareil sous la pluie et l'humidité
- The apparatus shall not be exposed to dripping or splashing and that no objects filled with liquids, such as vases, shall be placed on apparatus.  
L'appareil ne doit pas être exposé aux écoulements ou aux éclaboussures et aucun objet ne contenant de liquide, tel qu'un vase, ne doit être placé sur l'objet.
- The MAINS plug / power adaptor is used as the disconnect device, it should remain readily operable during intended use.  
In order to disconnect the apparatus from the mains completely, the main plug / power adaptor should be disconnected from the mains socket outlet completely.  
La prise du secteur ne doit pas être obstruée ou doit être facilement accessible pendant son utilisation. Pour être complètement déconnecté de l'alimentation d'entrée, la prise doit être débranchée du secteur.
- Battery shall not be exposed to excessive heat such as sunshine, fire or the like.  
Les piles ne doivent pas être exposées à de forte chaleur, tel qu'à la lumière du soleil, au feu ou autres choses de semblable.
- Caution Marking and rating plate was located at bottom enclosure of the apparatus. Les marquages sont inscrits en bas de l'appareil.  
Les précautions d'emploi sont inscrites en bas de l'appareil.
- Non-rechargeable batteries are not to be recharged,
- Rechargeable batteries are to be removed from the toy before being charged,
- Rechargeable batteries are only to be charged under adult supervision,
- Different types of batteries or new and used batteries are not to be mixed,
- Batteries are to be inserted with the correct polarity,
- Exhausted batteries are to be removed from the toy. The
- supply terminals are not to be short-circuited,
- Not connected more than recommended number of power supplied
- Warning ! Not suitable for children under 36 months
- The toy must only be used with the transformer for toys
- The toy is not intended for children under 3 years old
- The model number or specification of a suitable transformer for use with the toy
- The transformer is not a toy,
- Toys liable to be cleaned with liquid are to be disconnected from the transformer before cleaning.
- Transformers (Input 100 - 240V ~ 50/60 Hz 0.5A, Output DC 5V / 0.6A) used with the toy are to be regularly examined for damage to the cord, plug, enclosure and other parts, and that, in the event of such damage, the toys must not be used with this transformer until the damage has been repaired.

Symbols	Explanation
	Class II equipment
	AC voltage
	DC voltage
	Hazard live parts
	<p><b>RECYCLING</b></p> <p>This product bears the selective sorting symbol for Waste electrical and electronic equipment (WEEE). This means that this product must be handled pursuant to European directive 2012/19/EU in order to be recycled or dismantled to minimize its impact on the environment.</p> <p>User has the choice to give his product to a competent recycling organization or to the retailer when he buys a new electrical or electronic equipment.</p>

# WHAT'S IN THE BOX

---

## Contents

### 1. Candy House

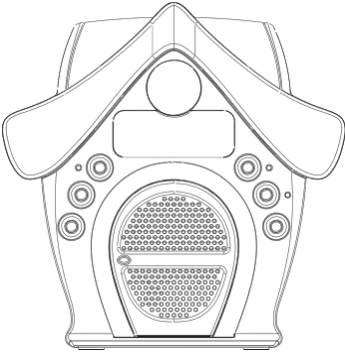

### 2. AC Power Adaptor

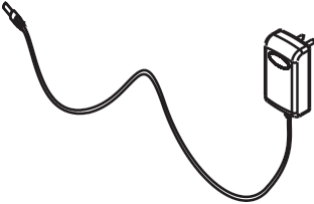

### 3. Line-in Cable



### 4. Microphone



### 5. Instruction Manual

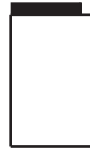

### 6. Warranty Card



# CONTROL LOCATIONS

---

Front View

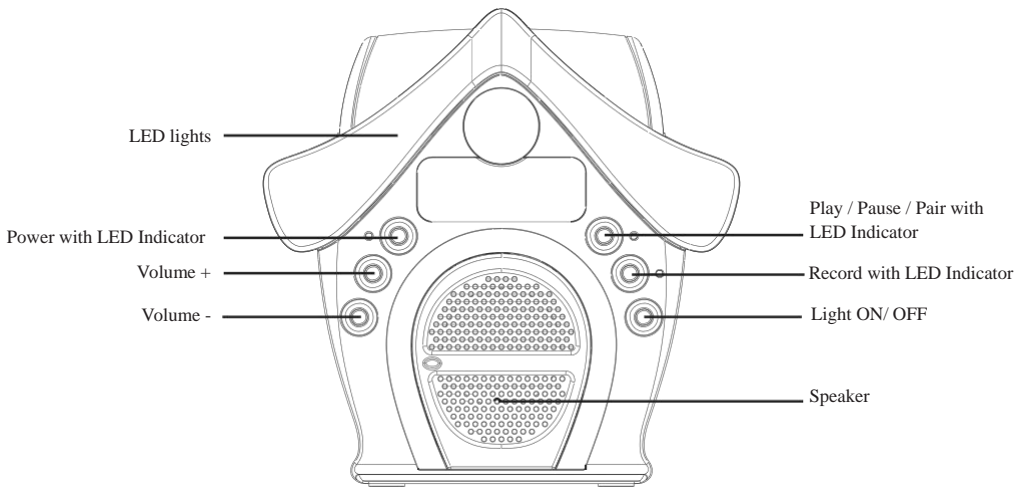

Back View

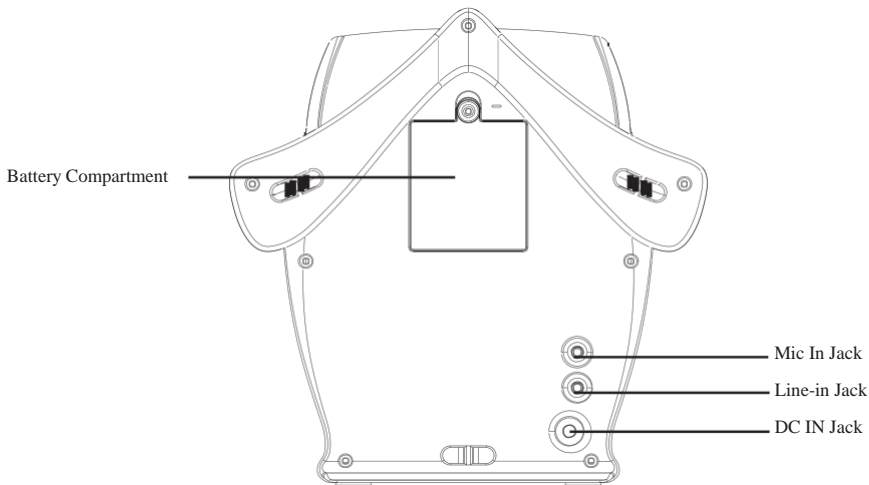

# POWER CONNECTION

## Connecting AC Power

Plug the Power Adaptor into the AC jack that located on the rear of the product and plug the other end into a standard AC socket.

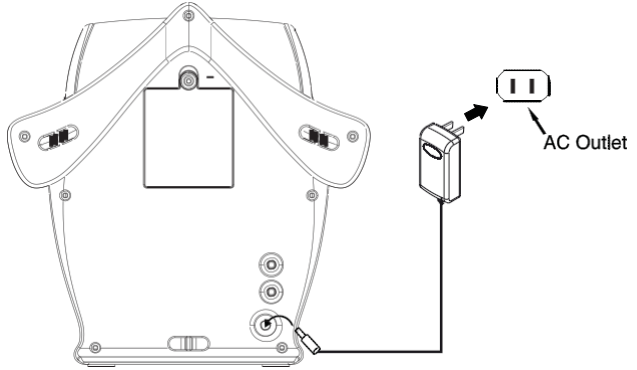

**CAUTION:** The AC Adaptor has a polarized plug that fits into the wall outlet only one way.

If the plug does not fit properly, turn it over and try again. Do not force it.

**NOTE:** When the unit is intended for being unused for a long period of the time. Please turn off the unit and unplug the power adaptor from the AC wall outlet.

## Battery Operation

Before installing batteries (not included), ensure that the unit is disconnected from the mains supply.

Remove the battery compartment cover on the bottom of the main unit AND the microphone by a screw driver. The battery covers can then be lifted away.

Fit 4 x 1.5V AA-size batteries (not included) into the main unit AND 2 x 1.5V AAA-size batteries into the microphone (not included).

Refer to the polarity markings inside the battery compartment. Never mix old and new batteries. Finally, replace the cover.

For battery operation, switch off the mains supply and remove the AC power adaptor from the power socket, battery operation will be selected automatically.

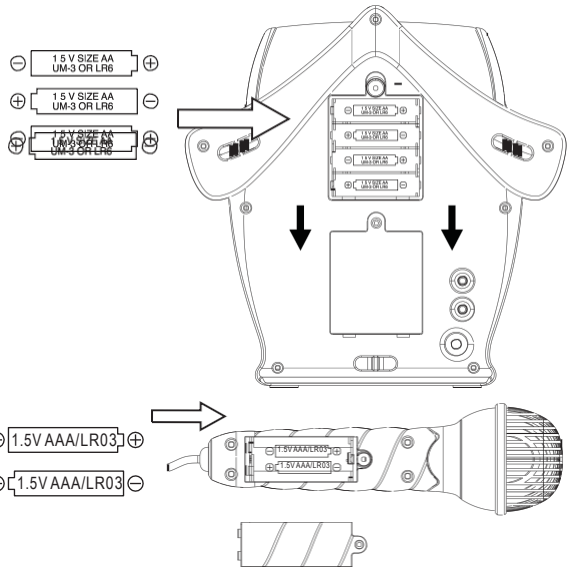

### **Caution:**

There is a danger of explosion if batteries are replaced incorrectly.

Replace batteries with the same type and same brand only.

If the unit will not be used for a long period of time, turn OFF the unit and microphone and remove all batteries from the main unit and microphone.



# LED LIGHT ON MAIN UNIT & MICROPHONE

## Main Unit

1. Press POWER button to turn on the main unit.
2. Press LIGHT ON/OFF button to switch on LED light on the roof top.
3. You will see the LED light flash.
4. Press LIGHT ON/OFF button again to switch it off.

## Microphone

1. Once you installed batteries, switch on the microphone the LED lights inside the microphone will be turned on.
2. Switch off the microphone and the light will turn off.

# BLUETOOTH PAIRING AND CONNECTION

## NOTE:

Before pairing, make sure the LINE IN cable is not plugged into the LINE IN jack.

### First time pairing

1. Press the power button to turn on the unit.
2. The unit will search the paired device with the Bluetooth indicator flashing quickly.
3. Turn on Bluetooth function of your device and enable the search or scan function to find the main unit. (See your device's instructions to add or setup a Bluetooth device).
4. Select "Candy House" from the device list when it appears on your device screen.
5. After successfully paired with a device, the Bluetooth indicator will stay lit in blue and you will hear "paired" which confirms the pairing had been done.

### To pair with another Bluetooth device

1. Press and hold the PAIR button for 2 seconds to unpair your Bluetooth device.
2. Repeat above step 2 to 5 to pair another Bluetooth device.

### Playing from a paired Bluetooth device

You can play music from your Bluetooth device wirelessly to the main unit by following the steps below after successfully paired.

1. To play your favorite song, press the PLAY button on your Bluetooth device to start playback.
2. Press the VOLUME +/- buttons on the main unit until you obtain a comfortable listening level.
3. Press the SKIP ◀▶ buttons of the Bluetooth device to skip to previous or next song. Note:
  1. Remember to turn off the main unit after you have finished listening.
  2. Please do not forget to switch off the power of your external audio device as well if you do not use it for other purpose.

### Establish a safe sound level

Over time your hearing will adapt to continuous loud sound and will give the impression that the volume has in fact been reduced. What seems normal to you may in fact be harmful. To guard against this before your hearing adapts, set the volume to a low level.

Slowly increase the level until you can hear comfortably and clearly and without distortion. Damage to your hearing is accumulative and is irreversible. Any ringing or discomfort in the ears indicates that the volume is too loud. Once you have established a comfortable listening level, do not increase the sound level.

### Adjusting the Volume

Press the VOLUME buttons to increase / decrease the volume.

# LINE-IN FUNCTION

---

1. Press POWER button to turn on the unit. Red LED indicator will turn on.
2. Plug a 3.5mm line-in cable into your external music player and connect the other end into the LINE IN jack on the back side of the unit.
3. Make sure your external music player is turned on and the unit has been turned on
4. Start music playback on your external music player.
5. Adjust volume by pressing Vol+ or Vol -
6. You can plug the microphone in and sing with music you play.

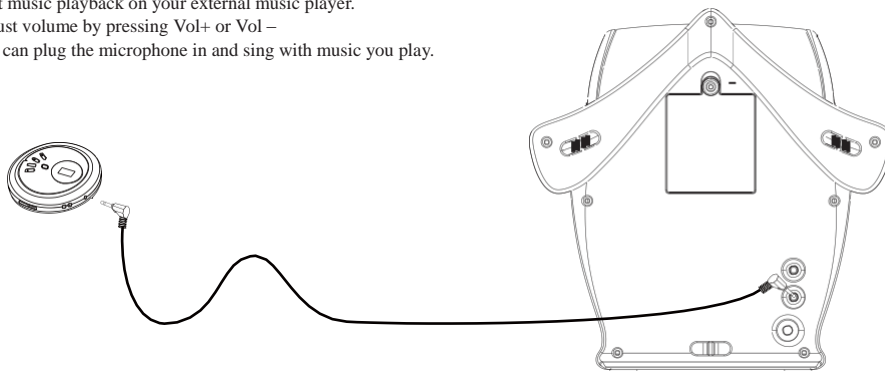

Note: the player is set to be LINE-IN priority which means once line-in cable plugged in, it will switch to LINE-IN mode automatically. To go back to Bluetooth mode unplug the line-in cable.

# RECORD AND PLAYBACK FUNCTION

---

1. You can sing while it is in Bluetooth or Line-in mode. Play music in Bluetooth or Line-in mode by following instructions in previous sections
2. Plug the microphone into the mic in jack at the back of the unit. Switch on your microphone and you can start to sing.
3. While you are singing, press record button, the record LED flashes. Your voice with music will be recorded. Press record button again to stop recording.
4. You can listen your recording by pressing the Play button. The record LED stays lit. Press the button again to stop.
5. Please note that each time when a new recording is being recorded it would cover the old recording.

# ENERGY SAVING

---

The unit will automatically turn into standby mode in 15 minutes in the following situations. The power LED indicator will be turned off:

1. No Bluetooth connection for 15 minutes
2. No playback from your external music player for 15 minutes.
3. No button being pressed for 15 minutes.
4. Not playing music & singing to the microphone for 15 minutes.

The unit would be turned on again by pressing any button. The power LED indicator will be turned on.

# TROUBLESHOOTING

If a fault occurs, first check the points listed below before taking the unit for repair. If you are unable to remedy a problem by following these hints, consult your dealer or service center.

WARNING: Under no circumstances should you try to repair the unit yourself, as this would invalidate the guarantee.

PROBLEM	POSSIBLE CAUSE	REMEDY
No sound in general	Volume not adjusted.	Press the vol + button
	No battery in battery compartment	Put 4 new AA size batteries into the battery compartment according to instructions
No sound from microphone	Microphone is switched off	Switch on the microphone
No sound in line in mode	The music player is not playing.	Start to play the music in your music player. Adjust volume by pressing volume buttons on the unit.
	The line in cord is not properly connected.	Follow instruction to connect the line in cord between the unit and the music player. Adjust volume by pressing volume buttons on the unit.
Bluetooth reception failure	The external device is far from the unit	Put the external BT device close to the unit.
	It is not paired	Pair the unit with the BT Device by following the procedures stated in this manual.

# TECHNICAL SPECIFICATION

## Power Supply

Main Unit

DC 6V ("AA" size 1.5V x 4pcs, not included)

Or

AC power adaptor

Input 100 - 240V ~ 50/60 Hz 0.5A

Output DC 5V / 1.2A

Microphone

DC 3V ("AAA" size 1.5V x 2pcs, not included)

**Line in**

3.5mm

**Power output**

2W (RMS)

**Dimension**

9.5"W x 9.6"H x 3.7"D

IMPORTANT: Due to continual revision and improvement on our product design, specifications are subject to change without further notice.