

AP-270 Series Outdoor Access Point

Installation Guide

The Aruba AP-274 and AP-275 are environmentally hardened, outdoor rated, dual-radio IEEE 802.11ac wireless access points. These access points use MIMO (Multiple-in, Multiple-out) technology and other high-throughput mode techniques to deliver high-performance, 802.11ac 2.4 GHz and 5 GHz functionality while simultaneously supporting existing 802.11a/b/g/n wireless services. The AP-270 Series access point works only in conjunction with an Aruba Controller.

AP-270 Series Operations

- Wireless transceiver
- Wireless access point (IEEE 802.11 a/b/g/n/ac)
- Wireless air monitor (IEEE 802.11 a/b/g/n/ac)
- Protocol-independent networking functionality
- Compatibility with IEEE 802.3at PoE
- Central management configuration and upgrades with an Aruba Controller.

Guide Overview

- ["AP-270 Series Hardware Overview" on page 3](#) provides a detailed hardware overview of the AP-274 and AP-275.
- ["Before You Begin" on page 7](#) provides key questions to ask and items to consider when deploying an outdoor wireless network.
- ["Installing the AP" on page 9](#) describes the multi-step process for a successful installation and deployment of the AP-274 and AP-275.
- ["Safety and Regulatory Compliance" on page 21](#) provides an overview of safety and regulatory compliance information.

Package Contents

- AP-274 or AP-275 Access Point
- Cable Glands x2
- Copper Lug x1
- M4x6 Screw x1
- USB Console Cable
- Installation Guide (this document)



The weatherproof caps for Ethernet, Console, and power interfaces are connected to the AP, not loose in the package.



Mounting kits for use with the AP-270 Series access points are sold separately. Contact your Aruba sales representative for details.



Inform your supplier if there are any incorrect, missing, or damaged parts. If possible, retain the carton, including the original packing materials. Use these materials to repack and return the unit to the supplier if needed.

AP-270 Series Hardware Overview

Figure 1 AP-275 Front View

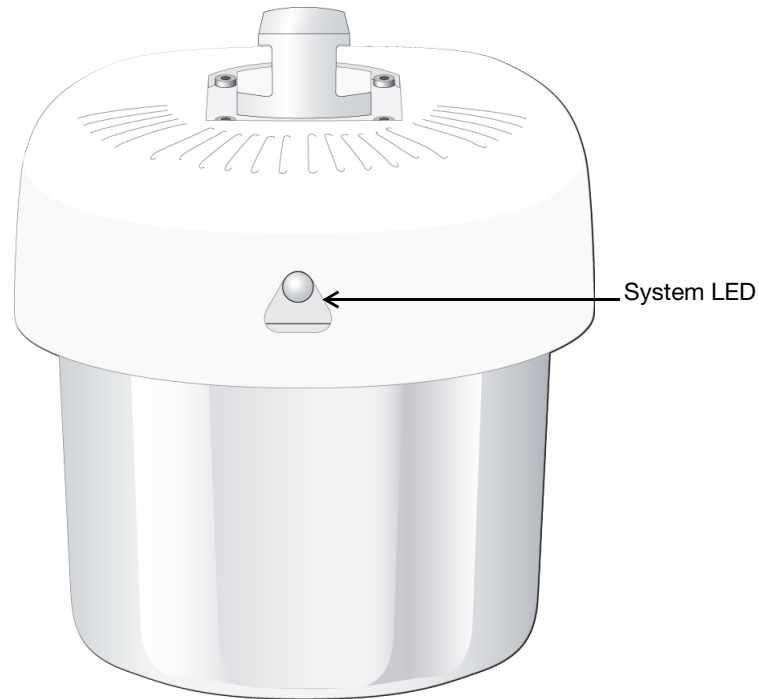
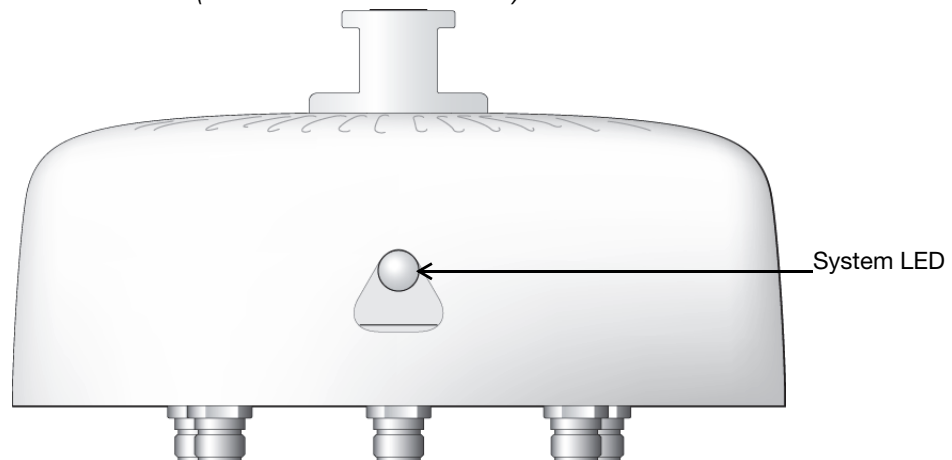

Figure 2 AP-274 Front View (Aesthetic Cover Removed)



The antenna connectors of AP-274 are covered by an aesthetic cover in the package. The aesthetic cover can be removed when necessary.

LED

The AP-270 Series is equipped with one LED that indicates the system status of the AP.

Table 1 AP-270 Series LED Meanings during Boot Up

LED	Color/State	Meaning
System LED	Off	No power to AP
	Red	Initial power-up
	Green - Flashing	AP booting
	Green - Steady	AP ready and 1000Mbps Ethernet link established. The LED turns off after 1200 seconds
	Green - Yellow, 6 seconds period	AP ready and 10/100Mbps Ethernet link established. The LED turns off after 1200 seconds

Table 2 AP-270 Series LED Meanings during Operation

LED	Color/State	Meaning
System LED	Solid Red	General fault
	One blink off every 3 seconds	Radio 0 fault (5 GHz)
	Two quick blink off 0.5 seconds apart cycled every 3 seconds	Radio 1 fault (2.4GHz)

Figure 3 AP-275 Rear View

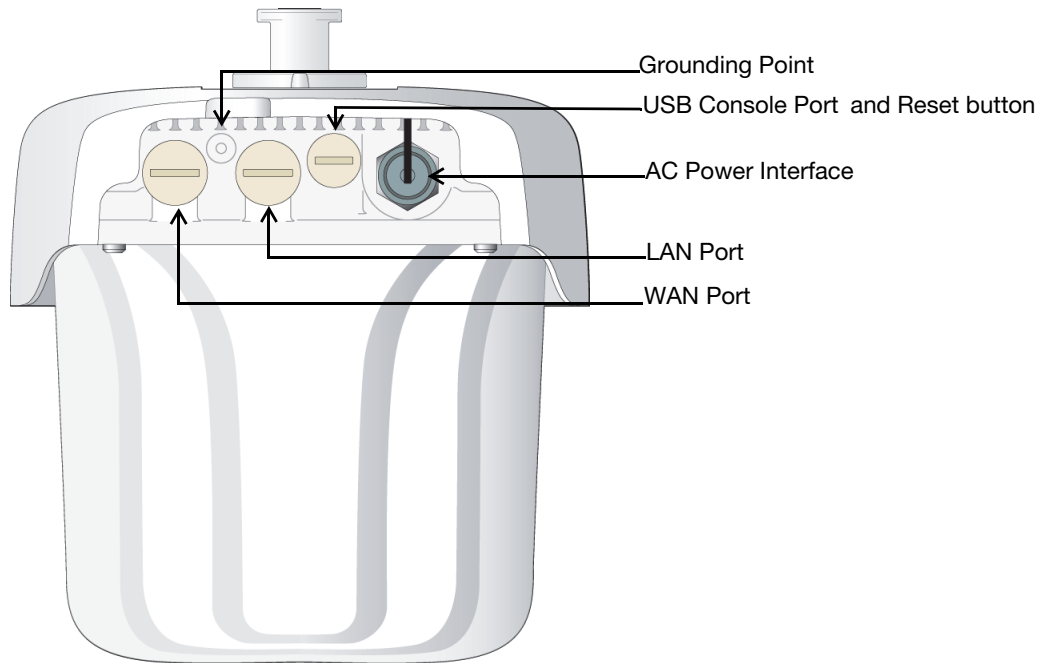
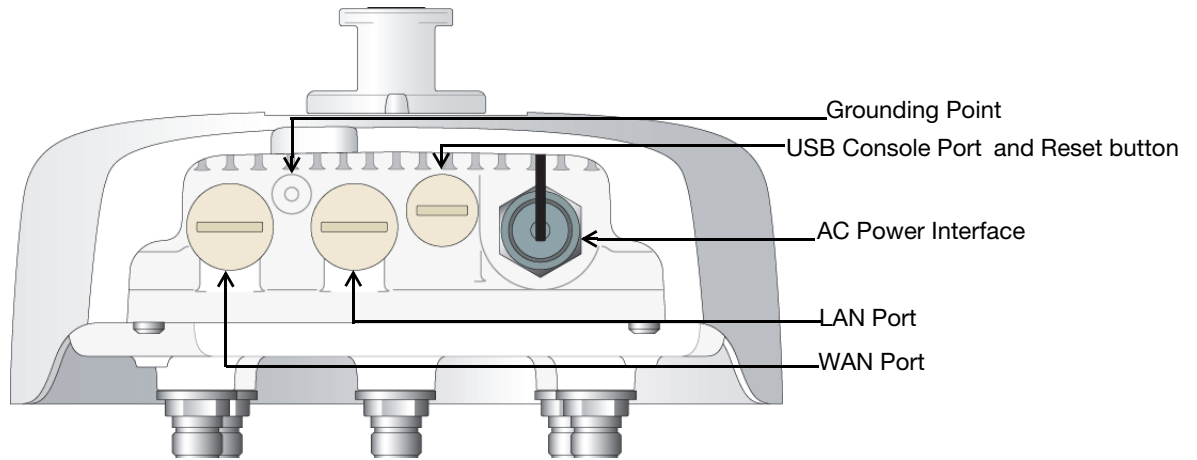

Figure 4 AP-274 Rear View



USB Console Port

The USB Micro-B console port allows you to connect the AP to a terminal or a laptop for direct local management. Use the included USB console cable to connect the AP. You can download the necessary driver for USB-UART adapter from support.arubanetworks.com under the **Tools & Resources** tab.

Use the following setting to access the terminal:

Table 3 Console Settings

Baud Rate	Data Bits	Parity	Stop Bits	Flow Control
9600	8	None	1	None

Ethernet Ports

AP-270 Series is equipped with two 10/100/1000Base-T (RJ-45) Gigabit Ethernet ports (WAN and LAN port) for wired network connectivity. The WAN port supports 802.3at Power over Ethernet (PoE), accepting 48 VDC (nominal) as a standard defined Powered Device (PD) from a Power Sourcing Equipment (PSE) such as a PoE midspan injector.

These ports have RJ-45 female connectors with the pin-outs shown in [Figure 5](#).

Figure 5 Gigabit Ethernet Port Pin-Out

1000Base-T Gigabit Ethernet Port	RJ-45 Female Pin-Out	Signal Name	Function
	1	BI_DA+	Bi-directional pair +A, POE Negative
	2	BI_DA-	Bi-directional pair -A, POE Negative
	3	BI_DB+	Bi-directional pair +B, POE Positive
	4	BI_DC+	Bi-directional pair +C, POE Positive
	5	BI_DC-	Bi-directional pair -C, POE Positive
	6	BI_DB-	Bi-directional pair -B, POE Positive
	7	BI_DD+	Bi-directional pair +D, POE Negative
	8	BI_DD-	Bi-directional pair -D, POE Negative

Reset Button

The reset button can be used to return the AP to factory default settings. To reset the AP:

1. Power off the AP.
2. Press and hold the reset button using a small, narrow object, such as a paperclip.
3. Power-on the AP without releasing the reset button. The system LED will flash within 5 seconds.
4. Release the reset button.

The system LED will flash again within 15 seconds indicating that the reset is completed. The AP will now continue to boot with the factory default settings.

AC Power Interface

The AP-270 Series is capable of AC power in the range of 100 - 240 VAC. The power cord or power connector kit is sold separately.

Grounding Point

Always remember to protect the AP by installing grounding lines. The ground connection must be complete before connecting power to the AP enclosure.

Figure 6 AP-275 Top View

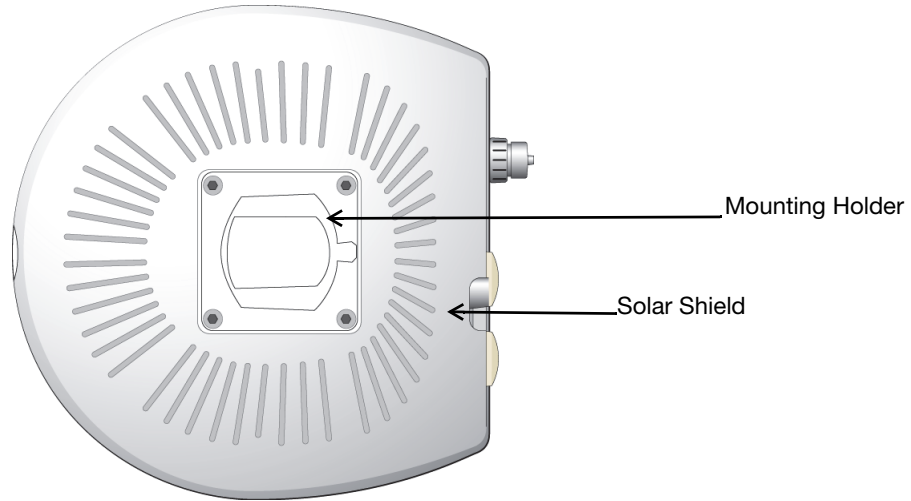
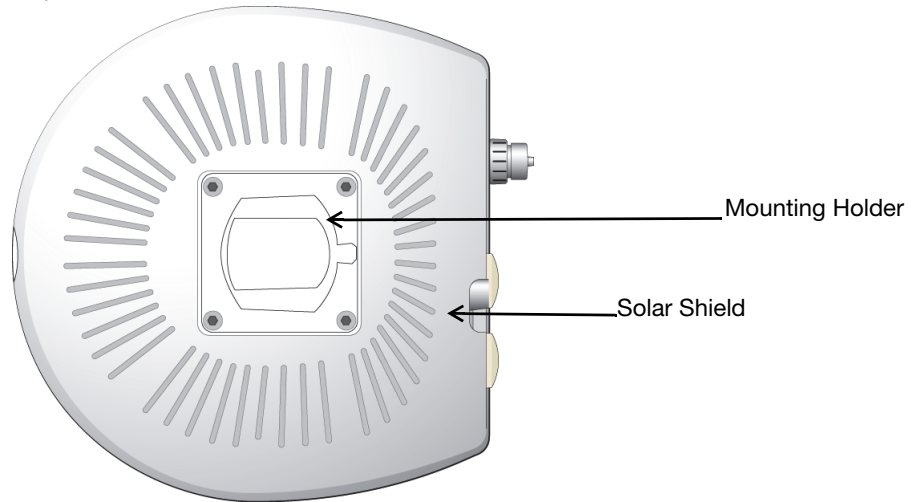

Figure 7 AP-274 Top View



At the top of the AP-270 Series, the solar shield with the mounting holder is fixed onto the AP before shipping from the factory.

Figure 8 AP-275 bottom View

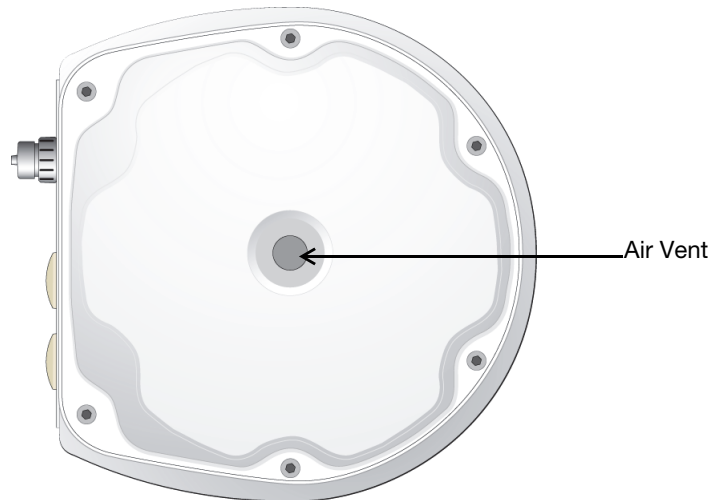
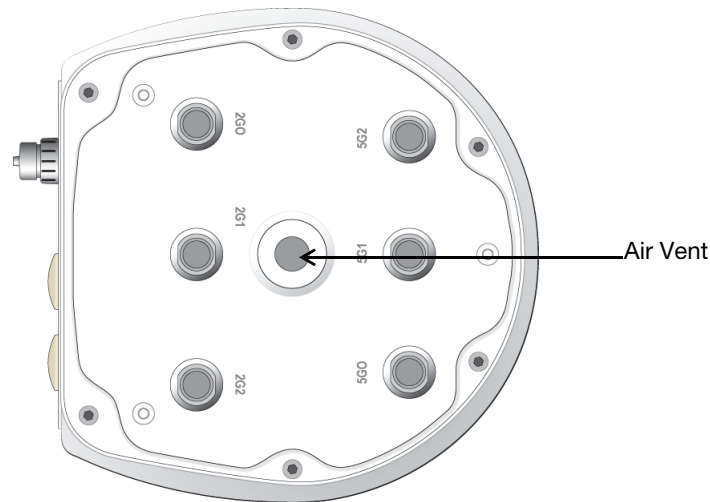

Figure 9 AP-274 bottom View



External Antenna Connectors

The AP-274 is equipped with six external antenna connectors. The connectors are labeled 2G0, 2G1, 2G2, 5G0, 5G1 and 5G2, and correspond to 2.4/5Ghz radio chains 0,1, and 2.

Air Vent

The bottom of the AP-270 Series has an air vent to balance the pressure and humidity inside and outside the AP. It also allows air exchange between the AP and the environment in a controlled way that doesn't allow water to get into the AP.

Before You Begin



FCC Statement: Improper termination of access points installed in the United States configured to non-US model controllers will be in violation of the FCC grant of equipment authorization. Any such willful or intentional violation may result in a requirement by the FCC for immediate termination of operation and may be subject to forfeiture (47 CFR 1.80).

EU Statement:

Lower power radio LAN product operating in 2.4 GHz and 5 GHz bands. Please refer to the *ArubaOS User Guide* for details on restrictions.



Produit réseau local radio basse puissance operant dans la bande fréquence 2.4 GHz et 5 GHz. Merci de vous référer au *ArubaOS User Guide* pour les détails des restrictions.

Low Power FunkLAN Produkt, das im 2.4 GHz und im 5 GHz Band arbeitet. Weitere Informationen bezüglich Einschränkungen finden Sie im *ArubaOS User Guide*.

Apparati Radio LAN a bassa Potenza, operanti a 2.4 GHz e 5 GHz. Fare riferimento alla *ArubaOS User Guide* per avere informazioni dettagliate sulle restrizioni.

Pre-Installation Network Requirements

After WLAN planning is complete and the appropriate products and their placement have been determined, the Aruba controller(s) must be installed and initial setup performed before the Aruba APs are deployed.

For initial setup of the controller, refer to the *ArubaOS Quick Start Guide* for the software version installed on your controller.

Pre-Installation Checklist

Before installing your AP-275, be sure that you have the items listed below:

- Gigabit Ethernet cable of required length
- IEEE 802.3at compliant PoE source or AC power source
- Aruba Mobility Controller configured and installed on the network
- Layer 2/3 network connectivity to your AP
- One of the following network services:
 - Aruba Discovery Protocol (ADP)
 - DNS server with an “A” record
 - DHCP Server with vendor specific options



Aruba Networks, Inc. in compliance with governmental requirements, has designed the AP-270 Series such that only authorized network administrators can change configuration settings. For more information about AP configuration, refer to the *ArubaOS Quick Start Guide* and *ArubaOS User Guide*.



Access points are radio transmission devices and as such are subject to governmental regulation. Network administrators responsible for the configuration and operation of access points must comply with local broadcast regulations. Specifically, access points must use channel assignments appropriate to the location in which the access point will be used.

Verifying Pre-Installation Connectivity

Before you install APs in a network environment, make sure that the APs will be able to locate and connect to the controller when they are powered on.

Specifically, you must verify the following conditions:

- When connected to the network, each AP is assigned a valid IP address.
- APs can locate the controller.

Refer to the *ArubaOS Quick Start Guide* for instructions on locating and connecting to the controller.

Identifying Specific Installation Locations

You can mount the AP-270 Series access point on a wall or pole. Use the AP placement map generated by Aruba's RF Plan software application to determine the proper installation location(s). Each location should be as close as possible to the center of the intended coverage area and should be free from obstructions or obvious sources of interference. These RF absorbers/reflectors/interference sources will impact RF propagation and should have been accounted for during the planning phase and adjusted for in RF plan.

Identifying Known RF Absorbers/Reflectors/Interference Sources

Identifying known RF absorbers, reflectors, and interference sources while in the field during the installation phase is critical. Make sure that these sources are taken into consideration when you attach an AP to its fixed location. Examples of sources that degrade RF performance include:

- Cement and brick
- Objects that contain water
- Metal
- Microwave ovens
- Wireless phones and headsets

Installing the AP



Service to all Aruba products should be performed by trained service personnel only.

Using the Mounting Kits

The AP-270 Series can be installed on a wall or attached to a pole by using mounting kits. These mounting kits are available as accessories and are sold separately:

SKU for Mounting Kits

Part Number	Description
AP-270-MNT-V1	Long mounting kit for wall and vertical pole mounting, 300 mm from vertical mounting asset.
AP-270-MNT-V2	Short mounting kit for wall and vertical pole mounting, 75 mm from vertical mounting asset.



The mounting kits above support multiple AP models. All installation images below show the 275 AP.



For details on AP-270-MNT-V1 and AP-270-MNT-V2, please refer to the *AP-270-MNT-V1 Installation Guide* and *AP-270-MNT-V2 Installation Guide*.

Figure 10 Mounting Bracket (AP-270-MNT-V1)

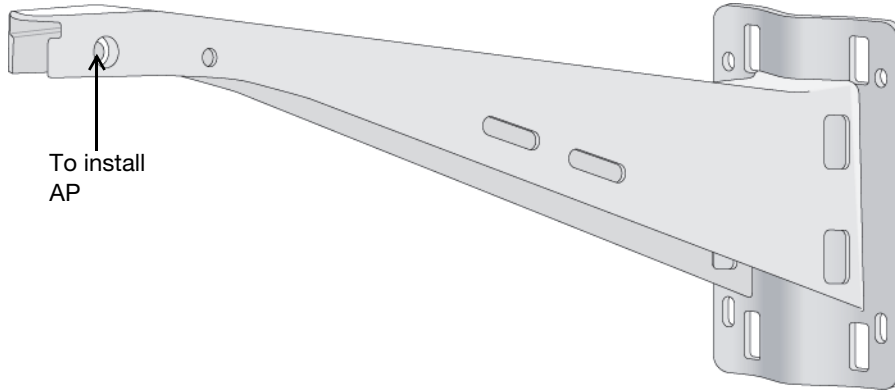
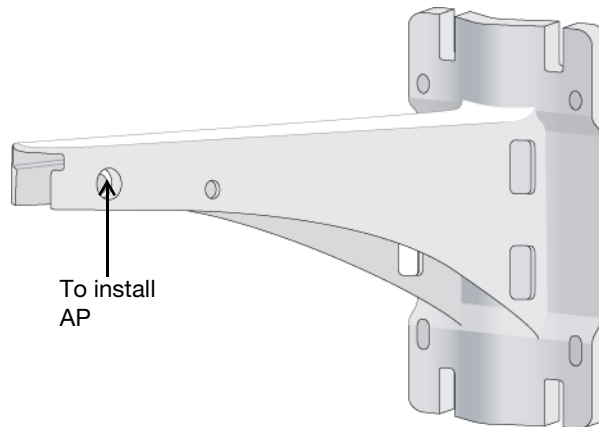

Figure 11 Mounting Bracket (AP-270-MNT-V2)



Mounting the AP to a Wall

1. Begin by marking the mounting points on the wall in the location you have selected.
 - a. Put the mounting bracket (included in the mount kit) on the installation position against the wall.
 - b. Using the mounting bracket as the template, mark four mounting points on the wall.
2. Use a drill to create four holes on the four markings you created in the previous step.
3. Insert an anchor bolt into each drilled hole. Anchor bolts are not included in the mount kit.
4. Place the mounting bracket over the anchor bolts and press the bracket against the wall.
5. Place the washers and nut onto the bolt's threaded end and tighten the nut till the mounting bracket is firmly attached to the wall as shown in [Figure 12](#) or [Figure 13](#).

Figure 12 Attaching the Mounting Bracket (AP-270-MNT-V1) to a Wall

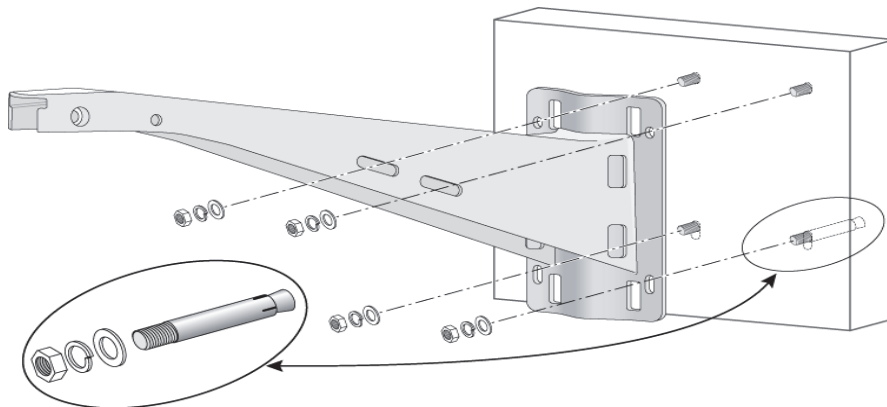
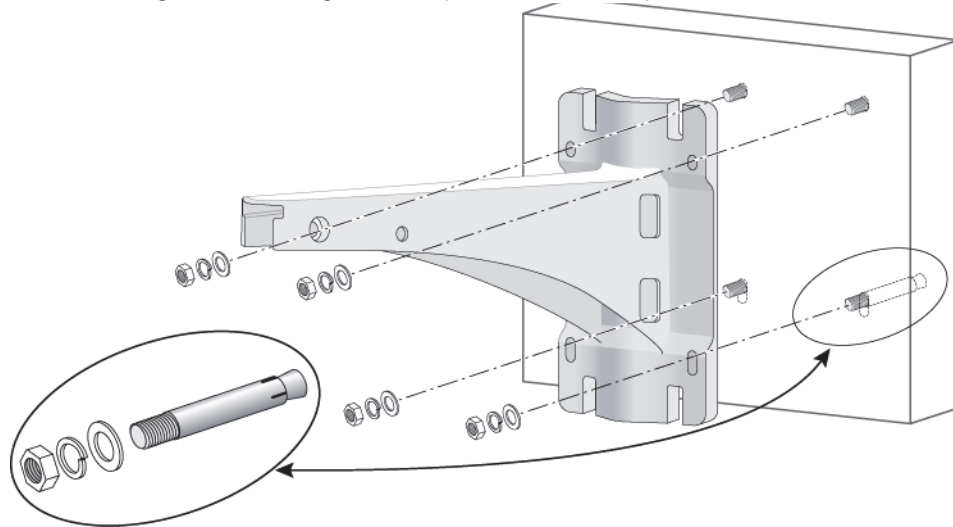

Figure 13 Attaching the Mounting Bracket (AP-270-MNT-V2) to a Wall



6. Slide the holder of the AP into the opening of the bracket and use the two screws to fix the holder as shown in [Figure 14](#) or [Figure 15](#).

Figure 14 Attaching the AP to the Mounting Bracket (AP-270-MNT-V1)

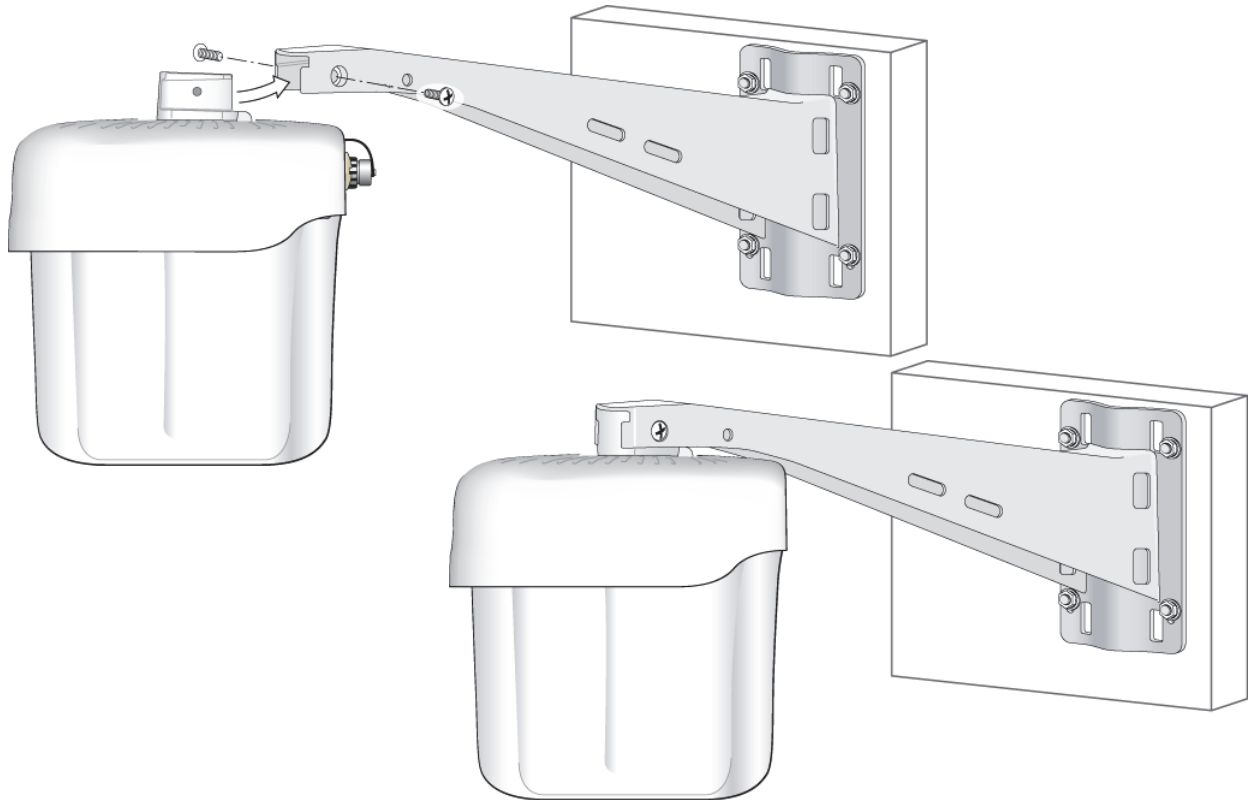
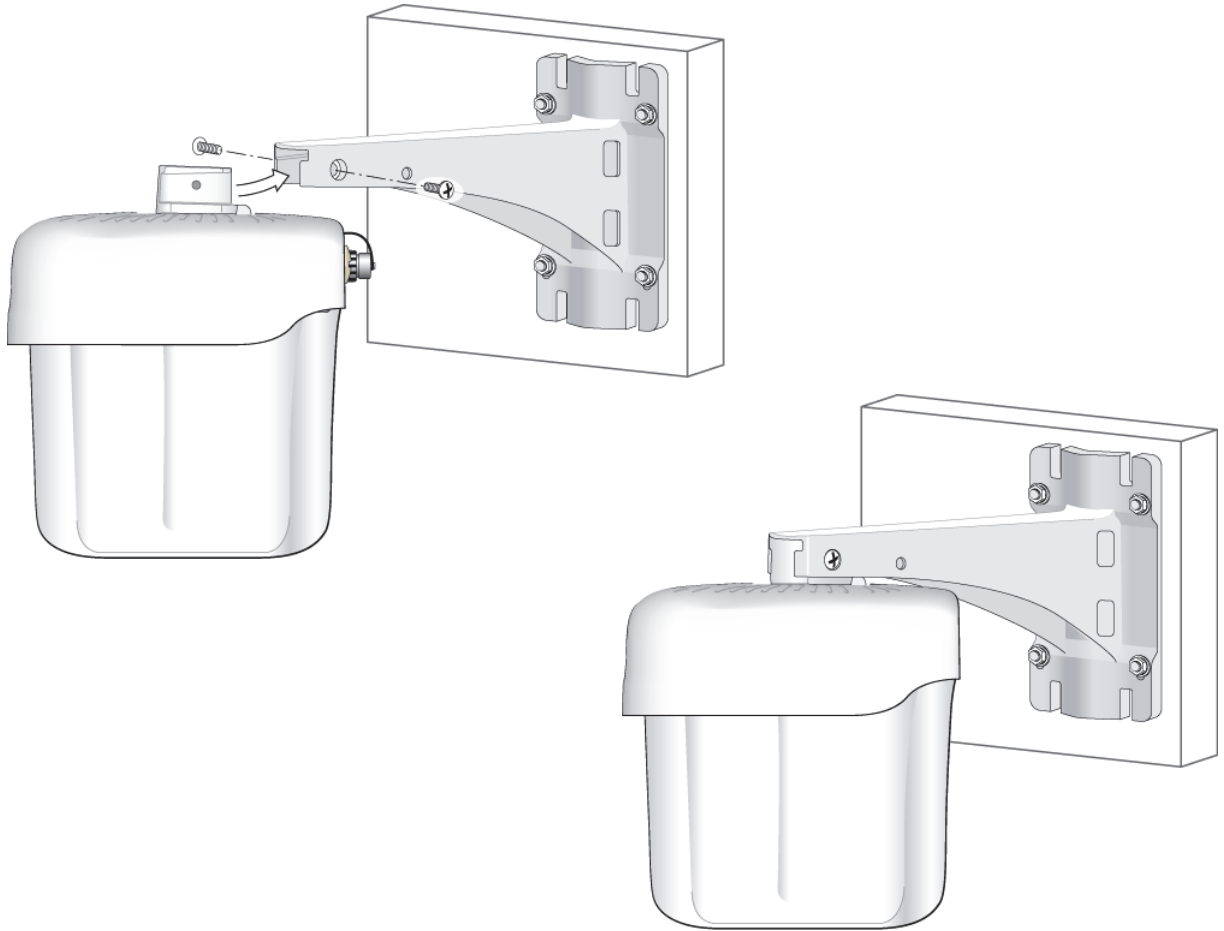

Figure 15 Attaching the AP to the Mounting Bracket (AP-270-MNT-V2)



7. Use the cable tie to fasten the cables on the bracket.
8. On the AP-274, install the external antennas according to the manufacturer's instructions, and connect the antennas to the antenna interfaces on the AP.

Mounting the AP to a Corner

The AP-270 Series can be installed on a corner of the wall by using AP-270-MNT-V2 and the Samsung Corner Mount Adaptor.



The Samsung Corner Mount Adaptor must be purchased separately.

1. Begin by attaching the Samsung Corner Mount Adaptor to the wall. Refer to Samsung's *Corner Mount Adaptor Installation Manual* for complete details.
2. Use the bolts and washers to mount the AP-270-MNT-V2 mounting bracket onto the Corner Mount Adaptor as shown in [Figure 16](#).

Figure 16 *Mounting the Mounting Bracket (AP-270-MNT-V2) to the Corner Mount Adaptor*

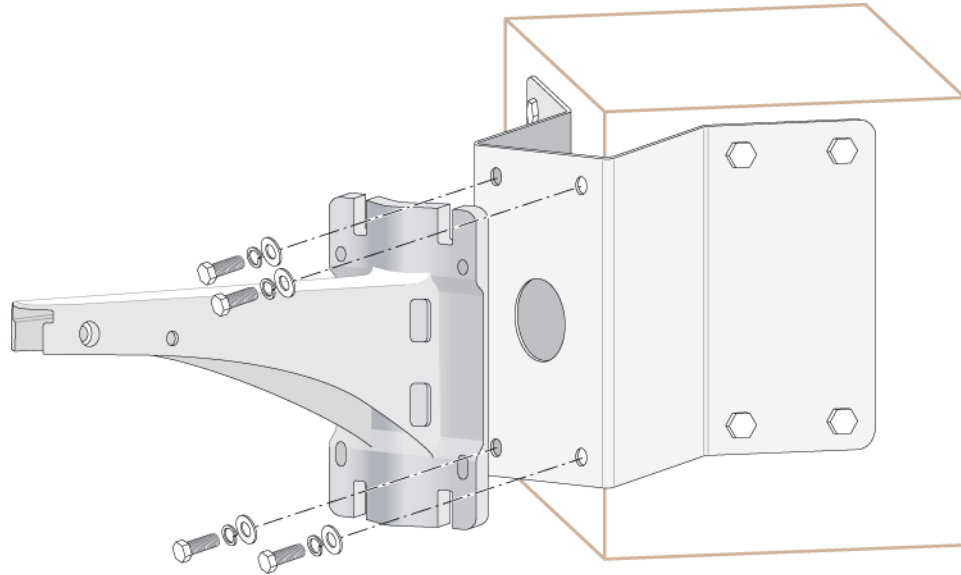

3. Slide the holder of the AP into the opening of the bracket and use the two screws to fix the holder as shown in [Figure 17](#).

Figure 17 *Attaching the AP to the Mounting Bracket (AP-270-MNT-V2)*

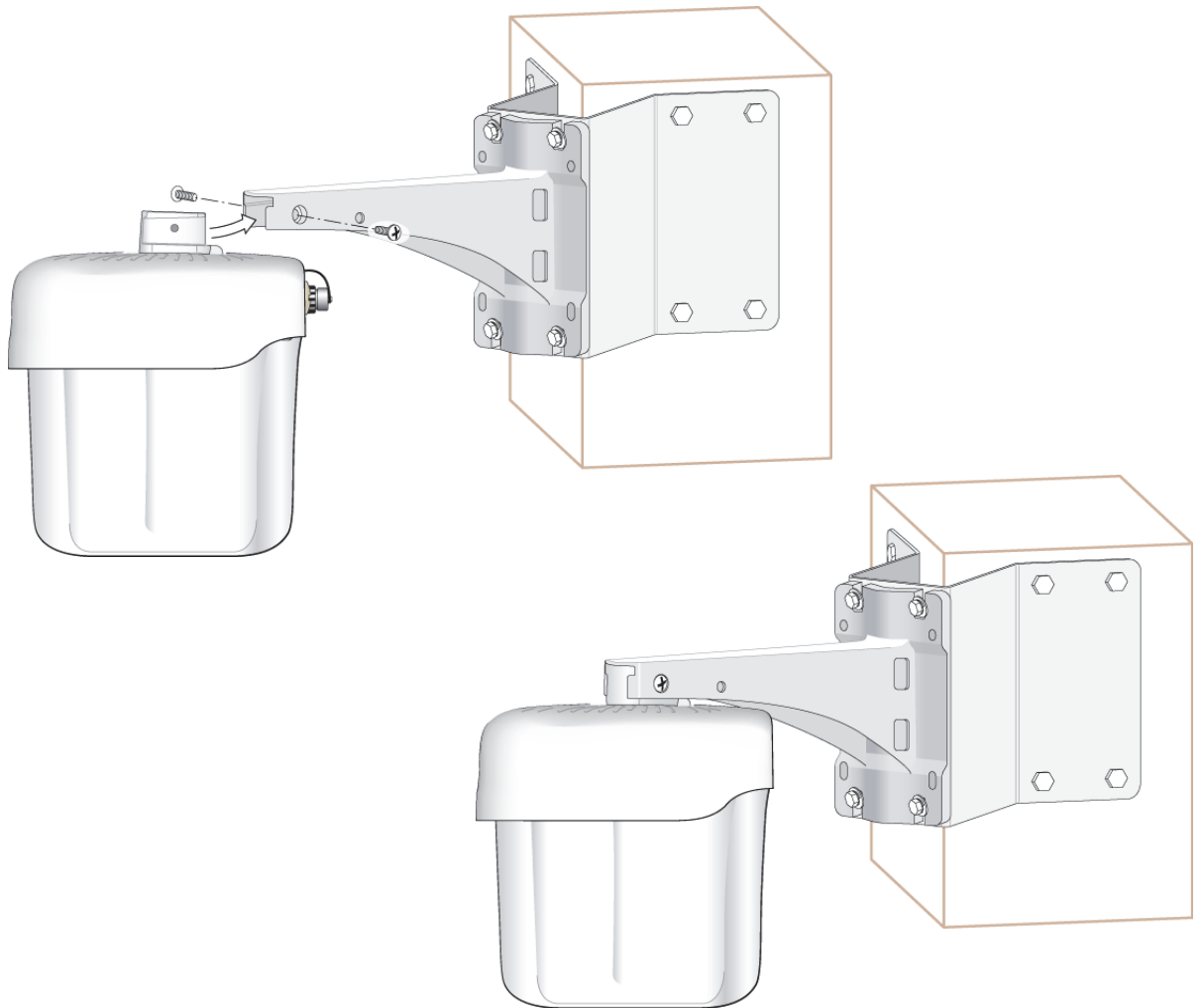

4. Use the cable tie to fasten the cables on the bracket.

5. On the AP-274, install the external antennas according to the manufacturer's instructions, and connect the antennas to the antenna interfaces on the AP.

Mounting the AP to a Vertical Pole

The mounting bracket provides different slots for pole mounting according to the diameter and shape of the pole as shown in [Figure 18](#) or [Figure 19](#).

1. Begin by attaching the mounting bracket to the vertical pole as shown in [Figure 18](#) or [Figure 19](#).
 - a. Pass a hose clamp through the two slots on the mounting bracket, attach the mounting bracket to the pole and tighten the clamp by using a screw driver to twist its screw head. Two hose clamps are included in the mount kit.
 - b. Use another hose clamp at the other two slots on the mounting bracket.

Figure 18 Attaching the Mounting Bracket (AP-270-MNT-V1) to a Vertical Pole

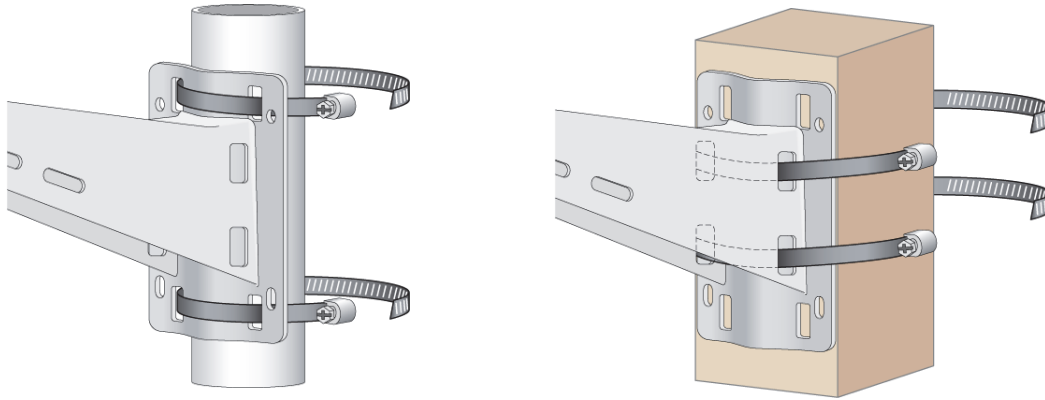
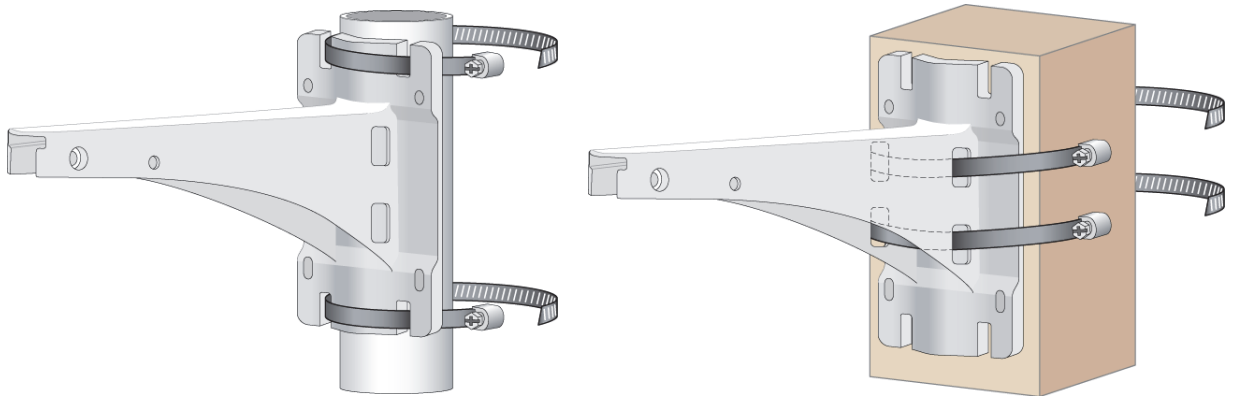

Figure 19 Attaching the Mounting Bracket (AP-270-MNT-V2) to a Vertical Pole



2. Slide the holder of the AP into the opening of the bracket and use the two screws to fix the holder as shown in [Figure 20](#) or [Figure 21](#).

Figure 20 Attaching the AP to the Mounting Bracket (AP-270-MNT-V1)

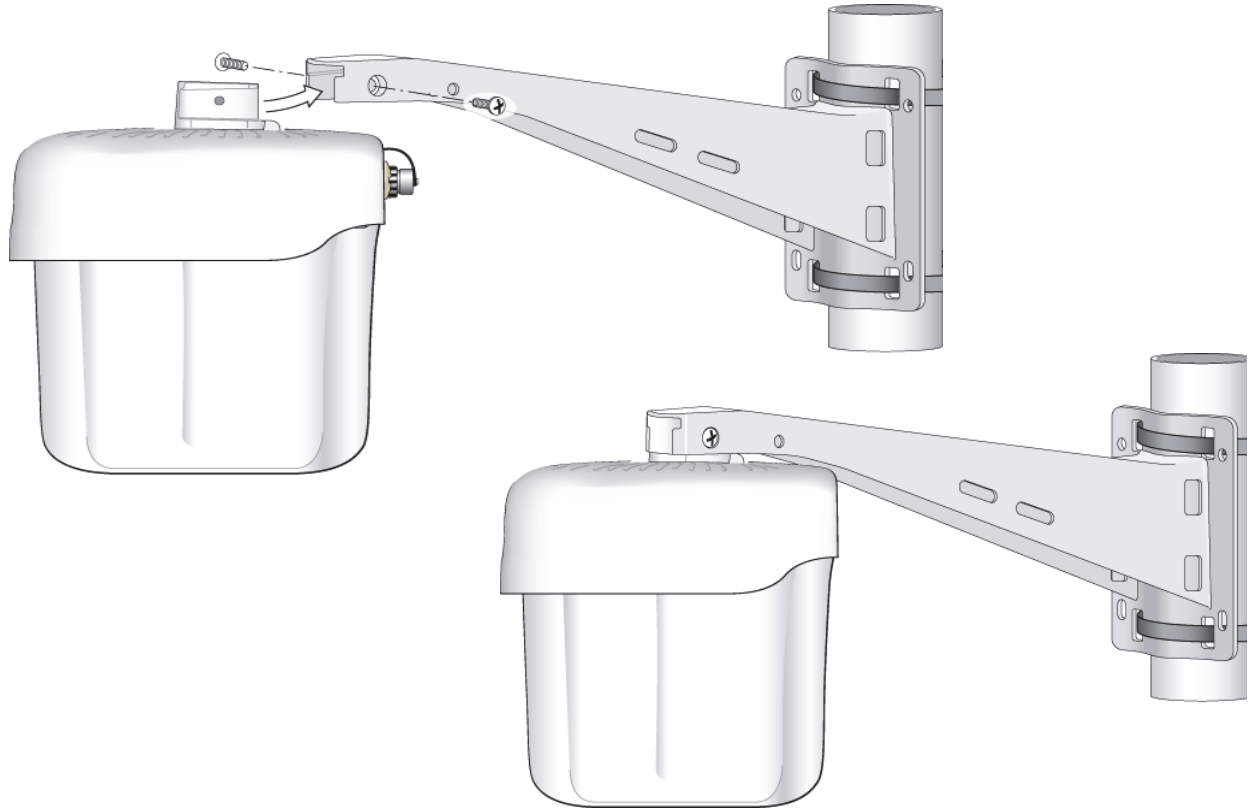

Figure 21 Attaching the AP to the Mounting Bracket (AP-270-MNT-V2)



3. Use the cable tie to fasten the cables on the bracket.
4. On the AP-274, install the external antennas according to the manufacturer's instructions, and connect the antennas to the antenna interfaces on the AP.

Grounding the AP

The grounding must be completed before powering up the AP. The grounding wire should be #8 AWG.

1. Peel the cover of one end of the grounding wire and place the bare grounding wire into the included copper lug, and press firmly with the crimping pliers.
2. Fasten the copper lug to the grounding hole on the AP with the included M4 x6 screw as shown in [Figure 22](#).

Figure 22 Grounding the AP

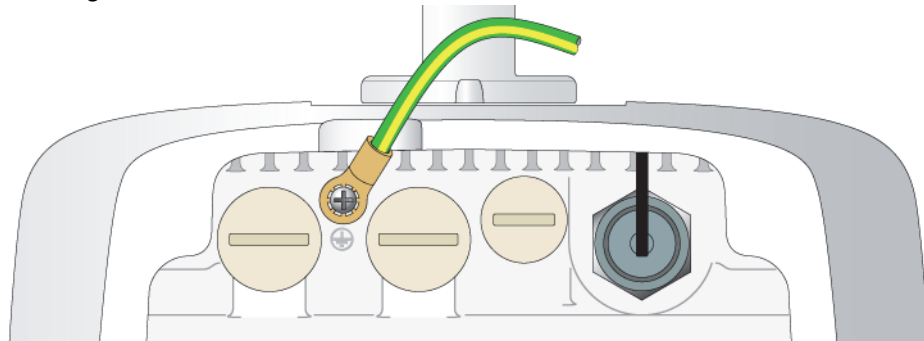

Connecting the Ethernet Cable

To connect the Ethernet cable to the AP, perform the following steps using the cable glands that ships with your AP.



Failure to use the included Ethernet cable glands can lead to connectivity and POE issues.



The cable is not included and must be purchased separately. Purchase a suitable UV-resistant, outdoor rated, CAT 5E or better RJ45 cable for use with the AP.

Figure 23 *Installing a Cable Gland*

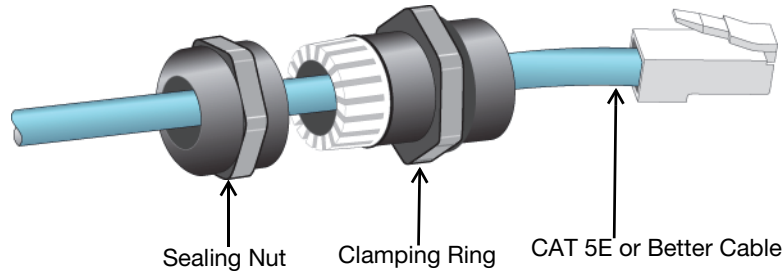

1. Slide the sealing nut over the cable (without the RJ45 connector attached to the end).
2. Slide the clamping ring over the cable.
3. Using a crimping tool, attach the shielded RJ45 connector to the end of the cable.
4. Remove the weatherproof cap on the Ethernet port.
5. Insert the RJ45 connector to the Ethernet port.
6. Screw the clamping ring onto the Ethernet port.
7. Screw the sealing nut onto the clamping ring.

Connecting the Power Cable



Installation and service of Aruba products should be performed by Professional Installers in a manner that is consistent with the electrical code in force in the jurisdiction of deployment. In many countries this will require a licensed electrician to perform this operation. In Japan, this is a Certified Electrician by Ministry of Economy, Trade, and Industry.



The AP-270 Series does not ship with any power cables. These are available as accessories and should be ordered separately.

The AP-270 Series product offering offers two ways to connect the unit to AC power. Two power cord variants are offered and a connector kit that allows the customer to assemble their own cable if the standard offering does not meet deployment needs.

The applicable SKUs for these options are:

Table 4 SKUs for Powering Options

Part Number	Description
PC-OD-AC-P-NA	Weatherproof AC power cable(5m), North America version
PC-OD-AC-P-INT	Weatherproof AC power cable(5m), International (EU) version
CKIT-OD-AC-P	Weatherproof connector kit for AC power interface

The difference between the NA and INTL part variants is the color coding of the conductors.

- The North American cable uses Black (Hot), White (Neutral), and Green (Ground).
- The INTL part follows the international schema of Brown (Hot), Blue (Neutral) and Yellow/Green (Ground)

Best Practice for Outdoor Connection to AC Mains

In all circumstances and with any outdoor infrastructure the recommended practice is to connect to AC mains in an order grade weather protected junction box. This needs to be implemented by a qualified resource in a manner that is consistent with the electrical code in force in the jurisdiction of deployment. In many countries this will require a licensed electrician to perform this operation.

In Japan, this would be a Certified Electrician by Ministry of Economy, Trade and Industry.

The use of plugs with infrastructure equipment is suitable only for temporary installs where nuisance tripping of GFI plugs is considered tolerable. Should it be desired to attach a plug to the cable assemblies then the installer is expected to follow all directions provided with the plug end in a fashion consistent with local electrical code.

Use of the CKIT-OD-AC-P

Assembly instructions for this part are shipped with the part. All instructions must be followed to ensure proper assembly of the connector onto the cable.

The required specifications for third party cable used with the CKIT solution are as follows:

- AC power cable specifications (when using AC connector kit and custom cable): minimum voltage/current rating 250V/1A, diameter 6-12mm, rated for outdoor use and UV exposure

AC Power Cable Connector PIN OUT

Figure 24 AC power cable connector

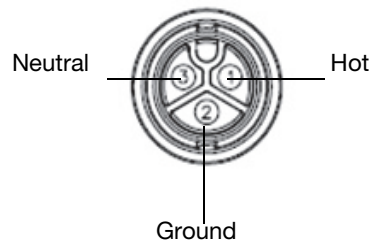

Connecting the Power Cable to the AP-275

1. Remove the weatherproof cap on the power interface.

2. Insert the power cable connector into the power interface and hand-fasten the locknut.

Verifying Post-Installation Connectivity

The integrated LEDs on the AP can be used to verify that the AP is receiving power and initializing successfully (see [Table 1](#) and [Table 2](#)). Refer to the *ArubaOS Quick Start Guide* for further details on verifying post-installation network connectivity.

Configuring the AP

AP Provisioning/Reprovisioning

Provisioning parameters are unique to each AP. These local AP parameters are initially configured on the controller which are then pushed out to the AP and stored on the AP itself. Aruba recommends that provisioning settings be configured via the ArubaOS Web UI only. Refer to the *ArubaOS User Guide* for complete details.

AP Configuration

Configuration parameters are network or controller specific and are configured and stored on the controller. Network configuration settings are pushed out to the AP(s) but remain stored on the controller.

Configuration settings can be configured via the ArubaOS Web UI or ArubaOS CLI. Refer to the *ArubaOS User Guide* for complete details.

Product Specifications

Mechanical:

- Device Dimensions (HxWxD)
 - AP-274 (without aesthetic cover): 5.5 inches x 9 inches x 9.4 inches (14cm x 23cm x 24cm)
 - AP-274 (with aesthetic cover): 7.5 inches x 9 inches x 9.4 inches (19cm x 23cm x 24cm)
 - AP-275: 10.6 inches x 9 inches x 9.4 inches (27cm x 23cm x 24cm)
- Weight
 - AP-274(without aesthetic cover): 5.3 lbs/2.4 kg
 - AP-274 (with aesthetic cover): 6lbs/2.7kg
 - AP-275: 5.3 lbs/2.4 kg

Electrical

- Ethernet
 - 2 x 10/100/1000Base-T auto-sensing Ethernet RJ-45 Interfaces
 - MDI/MDX
 - Power over Ethernet (IEEE 802.3at compliant), 48VDC/0.6A
- Power
 - 100-240 VAC 50/60 Hz from external AC power source
 - POE support on WAN port: 802.3at-compliant POE sourcing devices

Environmental

- Operating
 - Temperature: -40°C to 60°C (-40°F to 140°F)
 - Humidity: 5% to 95% non-condensing
- Storage
 - Temperature: -50°C to 85°C (-58°F to 185°F)

For additional specifications on this product, please refer to the data sheet. The data sheet can be found at www.arubanetworks.com.

Safety and Regulatory Compliance

Aruba Networks provides a multi-language document that contains country-specific restrictions and additional safety and regulatory information for all Aruba access points. This document can be viewed or downloaded from the following location: www.arubanetworks.com/safety_addendum

Regulatory Model Name

The following regulatory model names apply to the AP-270 Series:

- AP-274: APEX0101
- AP-275: APEX0100

FCC

This device is electronically labeled. To view the FCC ID:

1. Log into the controller WebUI
2. Navigate to **Maintenance > Controller > About**.



Aruba access points must be installed by a professional installer. The professional installer is responsible for ensuring that grounding is available and it meets applicable local and national electrical codes.



RF Radiation Exposure Statement: This equipment complies with FCC RF radiation exposure limits. This equipment should be installed and operated with a minimum distance of 13.78 inches (35 cm) between the radiator and your body for 2.4 GHz and 5 GHz operations. This transmitter must not be co-located or operating in conjunction with any other antenna or transmitter. When operated in the 5.15 to 5.25 GHz frequency range, this device is restricted to indoor use to reduce the potential for harmful interference with co-channel Mobile Satellite Systems.

FCC Class B Part 15

This device complies with Part 15 of the Federal Communications Commission (FCC) Rules. Operation is subject to the following two conditions:

- This device may not cause harmful interference.
- This device must accept any interference received, including interference that may cause undesired operation.



Changes or modifications to this unit not expressly approved by the party responsible for compliance could void the user's authority to operate this equipment.

This equipment has been tested and found to comply with the limits for a Class B digital device, pursuant to Part 15 of the FCC Rules. This equipment generates, uses and can radiate radio frequency energy and, if not installed and used in accordance with the manufacturer's instructions, may cause interference harmful to radio communications.

If this equipment does cause interference, which can be determined by turning the equipment off and on, the user is encouraged to try to correct the interference by one or more of the following measures:

- Reorient or relocate the receiving antenna.
- Increase the separation between the equipment and receiver.
- Connect the equipment to an outlet on a circuit different from that to which the receiver is connected.
- Consult the dealer or an experienced radio or TV technician for help.

EU Regulatory Conformance

Aruba Networks, Inc., hereby declares that the APEX0101 and APEX0100 device models are in compliance with the essential requirements and other relevant provisions of Directive 1999/5/EC -CE(!). The Declaration of Conformity made under Directive 1999/5/EC is available for viewing at www.arubanetworks.com.

Proper Disposal of Aruba Equipment

For the most current information about Global Environmental Compliance and Aruba products, see our website at www.arubanetworks.com.

Waste of Electrical and Electronic Equipment



Aruba products at end of life are subject to separate collection and treatment in the EU Member States, Norway, and Switzerland and therefore are marked with the symbol shown at the left (crossed-out wheeled bin). The treatment applied at end of life of these products in these countries shall comply with the applicable national laws of countries implementing Directive 2002/96/EC on Waste of Electrical and Electronic Equipment (WEEE).

European Union RoHS



Aruba products also comply with the EU Restriction of Hazardous Substances Directive 2011/65/EC (RoHS). EU RoHS restricts the use of specific hazardous materials in the manufacture of electrical and electronic equipment. Specifically, restricted materials under the RoHS Directive are Lead (including Solder used in printed circuit assemblies), Cadmium, Mercury, Hexavalent Chromium, and Bromine. Some Aruba products are subject to the exemptions listed in RoHS Directive Annex 7 (Lead in solder used in printed circuit assemblies). Products and packaging will be marked with the “RoHS” label shown at the left indicating conformance to this Directive.

China RoHS



Aruba products also comply with China environmental declaration requirements and are labeled with the “EFUP 10” label shown at the left.

有毒有害物质声明
Hazardous Materials Declaration

部件名称 (Parts)	有毒有害物质或元素 (Hazardous Substance)					
	铅 (Pb)	汞 (Hg)	镉 (Cd)	六价铬 (Cr ⁶⁺)	多溴联苯 (PBB)	多溴二苯醚 (PBDE)
电路板 (PCA Boards)	×	○	○	○	○	○
机械组件 (Mechanical Sub-Assemblies)	×	○	○	○	○	○
<p>○： 表示该有毒有害物质在该部件所有均质材料中的含量均在 SJ/T11363-2006 标准规定的限量要求以下。 Indicates that the concentration of the hazardous substance in all homogeneous materials in the parts is below the relevant threshold of the SJ/T11363-2006 standard.</p> <p>×： 表示该有毒有害物质至少在该部件的某一均质材料中的含量超出SJ/T11363-2006标准规定的限量要求。 Indicates that the concentration of the hazardous substance of at least one of all homogeneous materials in the parts is above the relevant threshold of the SJ/T11363-2006 standard.</p> <p>对销售之日的所售产品, 本表显示, 供应链的电子信息产品可能包含这些物质。 This table shows where these substances may be found in the supply chain of electronic information products, as of the date of sale of the enclosed product.</p>						
<p>此标志为针对所涉及产品的环保使用期标志。某些零部件会有一个不同的环保使用期 (例如, 电池单元模块) 贴在其产品上。 此环保使用期限只适用于产品是在产品手册中所规定的条件下工作。 The Environment-Friendly Use Period (EFUP) for all enclosed products and their parts are per the symbol shown here. The Environment-Friendly Use Period is valid only when the product is operated under the conditions defined in the product manual.</p> <div style="text-align: right;">  </div>						

Canadian Statement

Under Industry Canada regulations, this radio transmitter may only operate using an antenna of a type and maximum (or lesser) gain approved for the transmitter by Industry Canada. To reduce potential radio interference to other users, the antenna type and its gain should be so chosen that the equivalent isotropically radiated power (e.i.r.p.) is not more than that necessary for successful communication.

This device complies with Industry Canada licence-exempt RSS standard(s).

Operation is subject to the following two conditions: (1) this device may not cause interference, and (2) this device must accept any interference, including interference that may cause undesired operation of the device.

Caution:

This radio transmitter (identify the device by certification number, or model number if Category II) has been approved by Industry Canada to operate with the antenna types listed below with the maximum permissible gain and required antenna impedance for each antenna type indicated. Antenna types not included in this list, having a gain greater than the maximum gain indicated for that type, are strictly prohibited for use with this device.

Gain of antenna: 14.0dBi max/10dBi max;

Type of antenna: directional/omni;

Impedance of antenna: 50ohm

Le présent émetteur radio (identifier le dispositif par son numéro de certification ou son numéro de modèle s'il fait partie du matériel de catégorie I) a été approuvé par Industrie Canada pour fonctionner avec les types d'antenne énumérés ci-dessous et ayant un gain admissible maximal et l'impédance requise pour chaque type d'antenne. Les types d'antenne non inclus dans cette liste, ou dont le gain est supérieur au gain maximal indiqué, sont strictement interdits pour l'exploitation de l'émetteur.

Gain d'antenne: 14.0dBi maximal/10dBi maximal;

Type d'antenne: 50 ohm, directionnel/omni.

Contacting Aruba Networks

Web Site Support	
Main Site	http://www.arubanetworks.com
Support Site	https://support.arubanetworks.com
Software Licensing Site	https://licensing.arubanetworks.com/login.php
Wireless Security Incident Response Team (WSIRT)	http://www.arubanetworks.com/support/wsirt.php
Support Emails	
• Americas and APAC	support@arubanetworks.com
• EMEA	emea.support@arubanetworks.com
WSIRT Email Please email details of any security problem found in an Aruba product.	wsirt@arubanetworks.com

Telephone Support	
Aruba Corporate	+1 (408) 227-4500
FAX	+1 (408) 227-4550
Support	
• United States	800-WI-FI-LAN (800-943-4526)
• Universal Free Phone Service Number (UJFN): Australia, Canada, China, France, Germany, Hong Kong, Ireland, Israel, Japan, Korea, Singapore, South Africa, Taiwan, and the UK.	+800-4WIFI-LAN (+800-49434-526)
• All Other Countries	+1 (408) 754-1200

Copyright

© 2014 Aruba Networks, Inc. AirWave®, Aruba Networks®, Aruba Mobility Management System®, Bluescanner, For Wireless That Works®, Mobile Edge Architecture, People Move. Networks Must Follow., RFprotect®, The All Wireless Workplace Is Now Open For Business, and The Mobile Edge Company® are trademarks of Aruba Networks, Inc. All rights reserved. All other trademarks are the property of their respective owners.



Open Source Code

Certain Aruba products include Open Source software code developed by third parties, including software code subject to the GNU General Public License (GPL), GNU Lesser General Public License (LGPL), or other Open Source Licenses. The Open Source code used can be found at this site:

http://www.arubanetworks.com/open_source

Legal Notice

The use of Aruba Networks, Inc. switching platforms and software, by all individuals or corporations, to terminate other vendors' VPN client devices constitutes complete acceptance of liability by that individual or corporation for this action and indemnifies, in full, Aruba Networks, Inc. from any and all legal actions that might be taken against it with respect to infringement of copyright on behalf of those vendors.

Warranty

This hardware product is protected by an Aruba warranty. For details, see the Aruba Networks standard warranty terms and conditions.



www.arubanetworks.com

1344 Crossman Avenue
Sunnyvale, California 94089

Phone: 408.227.4500

Fax 408.227.4550