

# Aruba AP-103H Wireless Access Point

The Aruba AP-103H wireless access point that supports the IEEE 802.11n standard for high-performance WLAN. This access point uses MIMO (Multiple-Input, Multiple-Output) technology and other high-throughput mode techniques to deliver high-performance, 802.11n 2.4 GHz or 5 GHz functionality while simultaneously supporting existing 802.11a/b/g wireless services. The AP-103H access point works only in conjunction with an Aruba Controller.

The Aruba AP-103H access point provides the following capabilities:

- Wireless transceiver
- Protocol-independent networking functionality
- IEEE 802.11a/b/g/n operation as a wireless access point
- IEEE 802.11a/b/g/n operation as a wireless air monitor
- Compatibility with IEEE 802.3af PoE
- Central management configuration and upgrades through an Aruba Controller

**NOTE** The Aruba AP-103H requires ArubaOS 6.4.1 or later.

## Package Contents

- AP-103H Access Point
- Single Gang Wall-box Mounting bracket
- 2x Mount Screws
- Installation Guide (this document)

**NOTE** Inform your supplier if there are any incorrect, missing, or damaged parts. If possible, retain the carton, including the original packing materials. Use these materials to repack and return the unit to the supplier if needed.

## Hardware Overview

Figure 1 Front

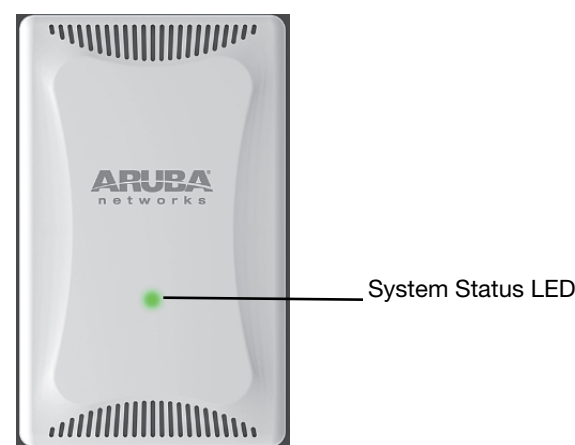

### LED

The AP-103H is equipped with one LED that indicates the system status of the AP.

Table 1 LED Meanings

LED	Color/State	Meaning
System Status LED	Off	No power to AP, or LED switched to 'off mode'
	Red	Error condition
	Green - Flashing	LED switched to 'blink mode'
	Green - Steady	AP ready
	Amber - Flashing	AP booting, or AP in Air or Spectrum monitor mode
	Amber - Steady	AP ready, restricted mode: <ul style="list-style-type: none"> <li>• 10/100Mbps uplink negotiated</li> <li>• Either radio in non-HT mode</li> </ul>

**NOTE** For more information on blink and off mode of the LED, refer to the ArubaOS User Guide.

Figure 2 Rear

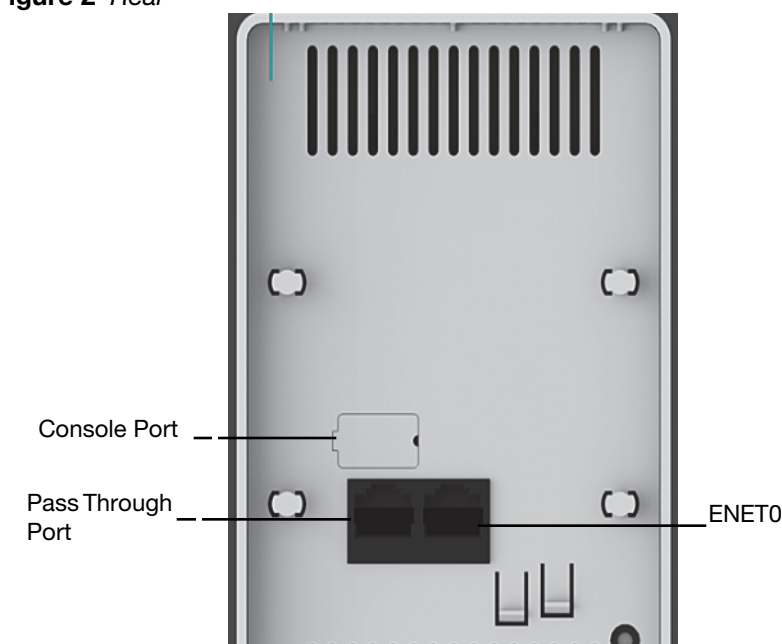

### Console Port

The serial console port allows you to connect the AP to a serial terminal or a laptop for direct local management. This port is a 4-pin connector covered by a dust cover. An optional serial adapter cable (AP-CBL-SER) is available for use with the IAP-103 and is sold separately.

**NOTE** The console port does not support hot-plug operation.

Figure 3 Bottom

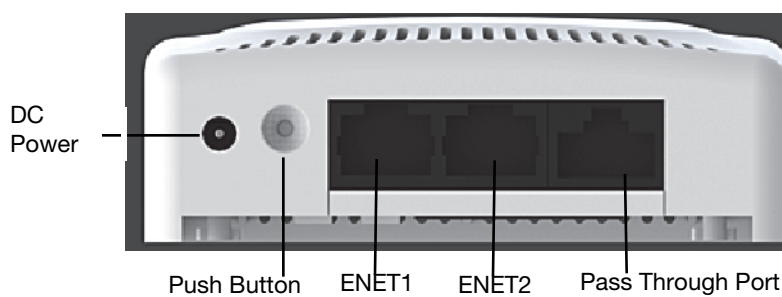

### Ethernet Ports

AP-103H is equipped with a total of three active Ethernet ports (ENET 0-2). ENET 0 is a 10/100/1000Base-T (RJ-45) auto-sensing, MDI/MDX wired-network uplink connectivity port. This port supports IEEE 802.3af Power over Ethernet (PoE), accepting 48VDC as a standard defined Powered Device (PD) from a Power Sourcing Equipment (PSE) such as a PoE midspan injector or network infrastructure that supports PoE. ENET 1 and 2 are 10/100Base-T (RJ-45) auto-sensing, MDI/MDX wired-network downlink connectivity ports, used to provide secure network connectivity to wired devices. ENET 0 is located on the rear of the AP, while ENET 1 and 2 are located on the bottom (Figure 3).

Additionally, AP-103H supports a passive pass-through RJ-45 interface to extend a physical connection (typically another Ethernet connection) from the back of the device to a connector on the bottom.

Figure 4 Gigabit Ethernet Port Pin-Out

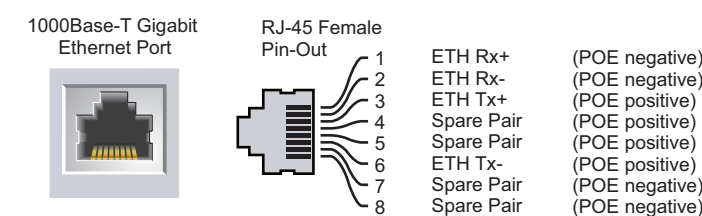
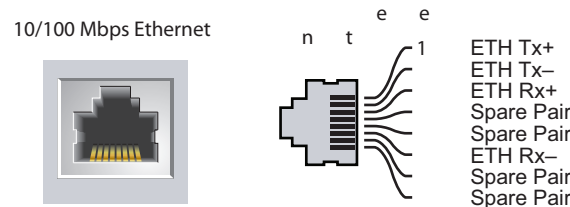

Figure 5 Fast Ethernet Port Pin-Out



### DC Power Socket

The AP-103H has a single 12V DC power jack socket to support powering through an AC-to-DC power adapter.

**NOTE** If both POE and DC power are available, the AP uses DC power, but a small current will be drawn from the POE power source as well.

### Push Button

The push button can be used to reset the AP to factory default settings or turn off/on the System Status LED.

- To reset the AP to factory default settings:

1. Power off the AP.
2. Press and hold the push button using a small, narrow object, such as a paperclip.
3. Power-on the AP without releasing the push button. The system status LED will flash within 5 seconds.
4. Release the push button.

The system status LED will flash again within 15 seconds indicating that the reset is completed. The AP will now continue to boot with the factory default settings.

- To turn off/on the system status LED:

During the normal operation of the AP, press the push button using a small, narrow object, such as a paperclip. The system status LED will be turned off/on immediately.

### Before You Begin

**CAUTION** **FCC Statement:** Improper termination of access points installed in the United States configured to non-US model controllers will be in violation of the FCC grant of equipment authorization. Any such willful or intentional violation may result in a requirement by the FCC for immediate termination of operation and may be subject to forfeiture (47 CFR 1.80).

**EU Statement:** Lower power radio LAN product operating in 2.4 GHz and 5 GHz bands. Please refer to the ArubaOS User Guide for details on restrictions.

Produit réseau local radio basse puissance operant dans la bande fréquence 2.4 GHz et 5 GHz. Merci de vous référer au ArubaOS User Guide pour les détails des restrictions.

Low Power FunkLAN Produkt, das im 2.4 GHz und im 5 GHz Band arbeitet. Weitere Informationen bezüglich Einschränkungen finden Sie im ArubaOS User Guide.

Apparati Radio LAN a bassa Potenza, operanti a 2.4 GHz e 5 GHz. Fare riferimento alla ArubaOS User Guide per avere informazioni dettagliate sulle restrizioni.

### Pre-Installation Network Requirements

After WLAN planning is complete and the appropriate products and their placement have been determined, the Aruba controller(s) must be installed and initial setup performed before the Aruba APs are deployed.

### AP Pre-Installation Checklist

Before installing your AP-103H access point, be sure that you have the following:

- Pre-installed wall box
- Cat5 UTP cable with network access installed in the wall box
- One of the following power sources:
  - IEEE 802.3af-compliant Power over Ethernet (PoE) source
  - Aruba AP AC-DC adapter kit (sold separately)
- Aruba Controller provisioned on the network:
  - Layer 2/3 network connectivity to your access point

One of the following network services:

- Aruba Discovery Protocol (ADP)
- DNS server with an "A" record
- DHCP Server with vendor-specific options

### Summary of the Setup Process

**NOTE** It is important that you verify the items listed under AP Pre-Installation Checklist before you attempt to set up and install an AP-103H.

Successful setup of an AP-103H access point consists of five tasks, which must be performed in this order:

1. Verify pre-installation connectivity.
2. Identify the specific installation location for each AP.
3. Install each AP.
4. Verify post-installation connectivity.

### 5. Configure each AP.

**NOTE** Aruba Networks, Inc., in compliance with governmental requirements, has designed the AP-93H access points so that only authorized network administrators can change the settings. For more information about AP configuration, refer to the ArubaOS Quick Start Guide and ArubaOS User Guide.

**CAUTION** Access points are radio transmission devices and as such are subject to governmental regulation. Network administrators responsible for the configuration and operation of access points must comply with local broadcast regulations. Specifically, access points must use channel assignments appropriate to the location in which the access point will be used.

### Verifying Pre-Installation Connectivity

Before you install APs in a network environment, make sure that the APs are able to locate and connect to the controller after power on. Specifically, you must verify the following conditions:

- When connected to the network, each AP is assigned a valid IP address
- APs are able to locate the controller

Refer to the ArubaOS Quick Start Guide for instructions on locating and connecting to the controller.

### Identifying Specific Installation Locations

You can mount the AP-93H access point on a wall or on the ceiling. Use the AP placement map generated by Aruba's RF Plan software application to determine the proper installation location(s). Each location should be as close as possible to the center of the intended coverage area and should be free from obstructions or obvious sources of interference. These RF absorbers/reflectors/interference sources will impact RF propagation and should have been accounted for during the planning phase and adjusted for in RF plan.

### Identifying Known RF Absorbers/Reflectors/Interference Sources

Identifying known RF absorbers, reflectors, and interference sources while in the field during the installation phase is critical. Make sure that these sources are taken into consideration when you attach an AP to its fixed location.

RF absorbers include:

- Cement/concrete—Old concrete has high levels of water dissipation, which dries out the concrete, allowing for potential RF propagation. New concrete has high levels of water concentration in the concrete, blocking RF signals.
- Natural Items—Fish tanks, water fountains, ponds, and trees
- Brick

RF reflectors include:

- Metal Objects—Metal pans between floors, rebar, fire doors, air conditioning/heating ducts, mesh windows, blinds, chain link fences (depending on aperture size), refrigerators, racks, shelves, and filing cabinets.
- Do not place an AP between two air conditioning/heating ducts. Make sure that APs are placed below ducts to avoid RF disturbances.

RF interference sources include:

- Microwave ovens and other 2.4 or 5 GHz objects (such as cordless phones)
- Cordless headset such as those used in call centers or lunch rooms

### Installing the AP

The AP-103H is designed to mount into a variety of electrical gang boxes. To install your AP-103H:

1. Begin by removing the existing data wall plate (if applicable).

Figure 6 Removing Wall Plate (Standard US Single Gang Outlet Box Shown)

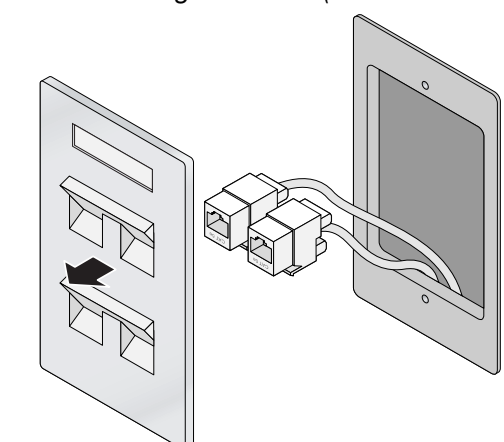



- Remove any existing RJ45 connectors (typically snap-in) or cut/remove the UTP cable.
- Use two short Ethernet cables (sold separately) to connect the AP to the RJ45 connectors or crimp an RJ45 plug (not supplied) on the cable (or both cables if using the pass through).
- Align the mounting holes of the AP-103H mounting bracket with mounting holes in you gang box as shown in [Figure 7](#)

**Figure 7** Bracket to Gang Box (Standard US Single Gang Outlet Box Shown)

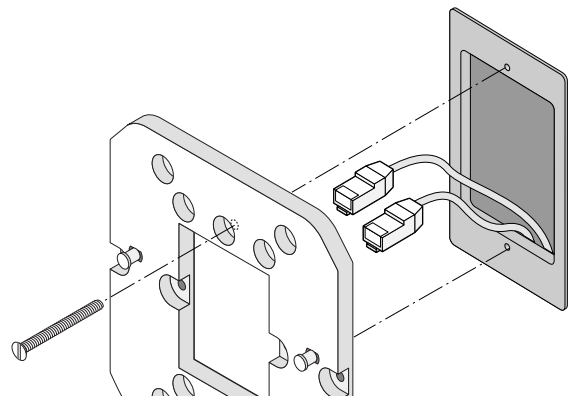

- Connect any required cables to the rear of the AP-103H.
- Align the mounting posts on the back of your AP-103H with the corresponding mounting holes on the mounting bracket as shown in [Figure 8](#).
- Push the AP against the holes and downward until the posts engage the slots at the top of the mounting holes.

**Figure 8** AP-103H to Bracket

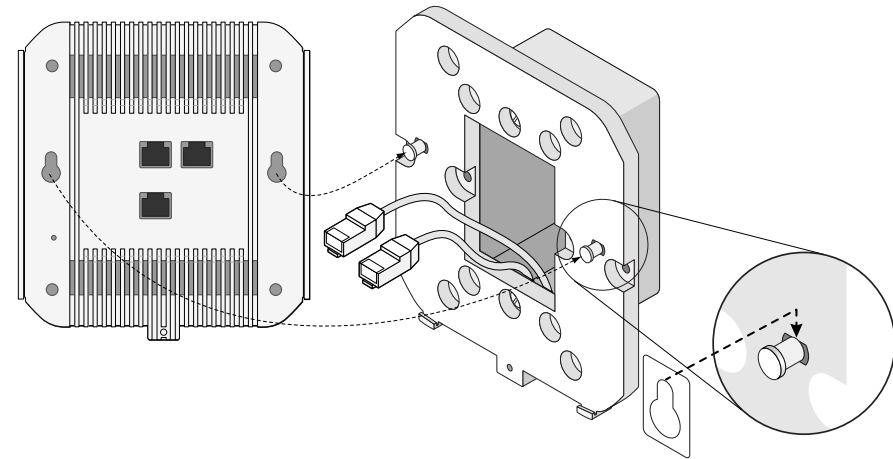

- To remove the AP-103H from the mounting bracket, begin by inserting the enclosed security key into the hole.
- Use the security key to depress the tab on the AP and push the AP up, releasing the AP from the mounting holes on the bracket.
- If not using PoE, connect the AC-DC power adapter (sold separately) to the DC power socket located on the bottom of the AP-103H.

## Verifying Post-Installation Connectivity

The integrated LED on the AP can be used to verify that the AP is receiving power and initializing successfully (see [Table 1](#)). Refer to the *ArubaOS Quick Start Guide* for further details on verifying post-installation network connectivity.

## Configuring the AP-103H

### AP Provisioning/Reprovisioning

Provisioning parameters are unique to each AP. These local AP parameters are initially configured on the controller which are then pushed out to the AP and stored on the AP itself. Aruba recommends that provisioning settings be configured via the ArubaOS Web UI only. Refer to the *ArubaOS User Guide* for complete details.

### AP Configuration

Configuration parameters are network or controller specific and are configured and stored on the controller. Network configuration settings are pushed out to the AP(s) but remain stored on the controller.

Configuration settings can be configured via the ArubaOS Web UI or ArubaOS CLI. Refer to *ArubaOS User Guide* for details.

## Product Specifications

### Electrical

- Ethernet:
  - 1 x 10/100/1000Base-T auto-sensing Ethernet RJ-45 Interface (ENET 0)
  - 2 x 10/100Base-T auto-sensing Ethernet RJ-45 Interfaces (ENET 1)
  - MDI/MDX
  - IEEE 802.3 (10Base-T), IEEE 802.3u (100Base-T), IEEE 802.3ab (1000Base-T)
  - Power over Ethernet (IEEE 802.3af compliant), 48V DC (nominal) and 56V DC (maximum)/350mA (see [Figure 4](#) for pin configuration)
- Power:
  - 12 VDC power interface, supports powering through an AC-to-DC power adapter

- POE support on Ethernet ports: 802.3af-compliant POE sourcing device



If a power adapter other than the one provided by Aruba Networks is used in the US or Canada, it should be NRTL Listed, with an output rated 12 VDC, minimum 1.25A, marked "LPS" or "Class 2," and suitable for plugging into a standard power receptacle in the US and Canada.

For additional specifications on this product, please refer to the data sheet. The data sheet can be found at [www.arubanetworks.com](http://www.arubanetworks.com).

## Proper Disposal of Aruba Equipment

For the most current information about Global Environmental Compliance and Aruba products, see our website at [www.arubanetworks.com](http://www.arubanetworks.com).

### Waste of Electrical and Electronic Equipment

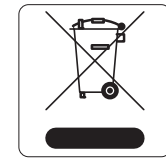

Aruba products at end of life are subject to separate collection and treatment in the EU Member States, Norway, and Switzerland and therefore are marked with the symbol shown at the left (crossed-out wheelee bin). The treatment applied at end of life of these products in these countries shall comply with the applicable national laws of countries implementing Directive 2002/96/EC on Waste of Electrical and Electronic Equipment (WEEE).

### India RoHS

This product complies with RoHS requirements as prescribed by E-Waste (Management & Handling) Rules, governed by the Ministry of Environment & Forests, Government of India.

### European Union RoHS

Aruba products also comply with the EU Restriction of Hazardous Substances Directive 2011/65/EC (RoHS). EU RoHS restricts the use of specific hazardous materials in the manufacture of electrical and electronic equipment. Specifically, restricted materials under the RoHS Directive are Lead (including Solder used in printed circuit assemblies), Cadmium, Mercury, Hexavalent Chromium, and Bromine. Some Aruba products are subject to the exemptions listed in RoHS Directive Annex 7 (Lead in solder used in printed circuit assemblies). Products and packaging will be marked with the "RoHS" label shown at the left indicating conformance to this Directive.

### China RoHS

Aruba products also comply with China environmental declaration requirements and are labeled with the "EFUP 25" label shown at the left.



有害物质声明 Hazardous Materials Declaration						
材料名称 (Part)	铅 (Pb)	汞 (Hg)	镉 (Cd)	六价铬 (Cr <sup>6+</sup> )	多溴联苯 (PBB)	多溴二苯醚 (PBDE)
电路板 (PCB boards)	x	o	o	o	o	o
封装器件 (Encapsulated Subsemblies)	x	o	o	o	o	o

o 表示该有害物质在所列材料中的含量符合 SJ/T 11363-2006 标准规定的限量要求。  
Indicates that the concentration of the hazardous substance in all homogeneous materials in the parts is below the relevant threshold of the SJ/T 11363-2006 standard.

x 表示该有害物质在所列材料中的含量不符合 SJ/T 11363-2006 标准规定的限量要求。  
Indicates that the concentration of the hazardous substance of at least one of all homogeneous materials in the parts is above the relevant threshold of the SJ/T 11363-2006 standard.

可回收之环保产品。本声明适用于所有产品。本声明包含环保信息。  
This table shows where these substances may be found in the supply chain of electronic information products, as of the date of sale of the enclosed product.

此标志为针对部分产品的环保使用标志。某些零件会有一个不同的环保使用标志。  
(例如,电路板)请见其产品上。  
此标志使用期限只适用于产品在生产过程中所规定的条件下。  
The Environment-Friendly Use Period (EFUP) for all enclosed products and their parts are per the symbol shown here. The Environment-Friendly Use Period is valid only when the product is operated under the conditions defined in the product manual.

turning the equipment off and on, the user is encouraged to try and correct the interference by one or more of the following measures:

- Reorient or relocate the device receiving the interference.
- Increase the separation between the equipment.
- Connect the equipment into an outlet on a circuit different from that to which the other device(s) are connected.
- Consult the manufacturer or field service technician for help.

The protection against electric shock is Class II.

Equipment not suitable for use in the presence of flammable mixtures.

### FCC Class B Part 15

This device complies with Part 15 of the Federal Communications Commission (FCC) Rules. Operation is subject to the following two conditions:

- This device may not cause harmful interference.
- This device must accept any interference received, including interference that may cause undesired operation.



Changes or modifications to this unit not expressly approved by the party responsible for compliance could void the user's authority to operate this equipment.

This equipment has been tested and found to comply with the limits for a Class B digital device, pursuant to Part 15 of the FCC Rules. This equipment generates, uses and can radiate radio frequency energy and, if not installed and used in accordance with the manufacturer's instructions, may cause interference harmful to radio communications.

If this equipment does cause interference, which can be determined by turning the equipment off and on, the user is encouraged to try to correct the interference by one or more of the following measures:

- Reorient or relocate the receiving antenna.
- Increase the separation between the equipment and receiver.
- Connect the equipment to an outlet on a circuit different from that to which the receiver is connected.
- Consult the dealer or an experienced radio or TV technician for help.

Complies with the Class B limits for radio noise emissions as set out in the interference-causing equipment standard entitled "Digital Apparatus," ICES-003 of Industry Canada.

Cet appareil numérique de la classe B respecte toutes les exigences du Règlement sur le matériel brouilleur du Canada.

Users are advised that high power Radars are allocated as primary users of the bands 5250-5350 MHz and 5650-5850 MHz and these Radars could cause interference and/or damage to Licensed Exempt WLAN devices.

### CE Regulatory Conformance

This product is CE marked according to the provisions of the R & TTE Directive (1999/5/EC) - CE(!). Aruba Networks Inc., hereby declares that the APIN103 device model is in compliance with the essential requirements and other relevant provisions of Directive 1999/5/EC - CE(!)

The Declaration of Conformity made under Directive 1999/5/EC is available for viewing at the following location: <http://support.arubanetworks.com>

Users are advised that high power Radars are allocated as primary users of the bands 5250-5350 MHz and 5650-5850 MHz and these Radars could cause interference and/or damage to Licensed Exempt WLAN devices.

### Canadian Statement

Under Industry Canada regulations, this radio transmitter may only operate using an antenna of a type and maximum (or lesser) gain approved for the transmitter by Industry Canada. To reduce potential radio interference to other users, the antenna type and its gain should be so chosen that the equivalent isotropically radiated power (e.i.r.p.) is not more than that necessary for successful communication.

This device complies with Industry Canada licence-exempt RSS standard(s).

Operation is subject to the following two conditions: (1) this device may not cause interference, and (2) this device must accept any interference, including interference that may cause undesired operation of the device.

## Safety and Regulatory Compliance

Aruba Networks provides a multi-language document that contains country-specific restrictions and additional safety and regulatory information for all Aruba access points. This document can be viewed or downloaded from the following location: [www.arubanetworks.com/safety\\_addendum](http://www.arubanetworks.com/safety_addendum)

### Regulatory Model Names

The following regulatory model name applies to the AP-103H:

- AP-103H: APINH103

### FCC

This device is electronically labeled. To view the FCC ID:

- Log into the controller WebUI.

Navigate to **Maintenance > Controller > About**.



Aruba access points must be installed by a professional installer. The professional installer is responsible for ensuring that grounding is available and it meets applicable local and national electrical codes.



RF Radiation Exposure Statement: This equipment complies with FCC RF radiation exposure limits. This equipment should be installed and operated with a minimum distance of 7.87 inches (20cm) between the radiator and your body for 2.4 GHz and 5 GHz operations. This transmitter must not be co-located or operating in conjunction with any other antenna or transmitter.

## EMC Compliance and Warning Statement

This equipment generates, uses and can radiate radio frequency energy, and, if not installed and used in accordance with the manufacturer's instructions may cause harmful interference to other devices in the vicinity. However, there is no guarantee that interference will not occur in a particular installation. If this equipment causes interference with other devices, which may be determined by

# Aruba AP-103H Wireless Access Point Installation Guide



## Contacting Aruba Networks

Web Support	
Main Site	<a href="http://www.arubanetworks.com">http://www.arubanetworks.com</a>
Support Site	<a href="https://support.arubanetworks.com">https://support.arubanetworks.com</a>
Airheads Social Forums and Knowledge Base	<a href="http://community.arubanetworks.com">community.arubanetworks.com</a>
North American Telephone	1-800-943-4526 (Toll Free) 1-408-754-1200
International Telephones	<a href="http://arubanetworks.com/support-services/aruba-support-program/contact-support/">arubanetworks.com/support-services/aruba-support-program/contact-support/</a>
Software Licensing Site	<a href="http://licensing.arubanetworks.com/login.php">licensing.arubanetworks.com/login.php</a>
Wireless Security Incident Response Team (WSIRT)	<a href="http://arubanetworks.com/support/wsirt.php">arubanetworks.com/support/wsirt.php</a>
Support Email Addresses	
Americas and APAC	<a href="mailto:support@arubanetworks.com">support@arubanetworks.com</a>
EMEA	<a href="mailto:emea.support@arubanetworks.com">emea.support@arubanetworks.com</a>
Americas and APAC Support Email	<a href="mailto:support@arubanetworks.com">support@arubanetworks.com</a>
WSIRT Email Please email details of any security problem found in an Aruba product.	<a href="mailto:wsirt@arubanetworks.com">wsirt@arubanetworks.com</a>

## Copyright

© 2014 Aruba Networks, Inc. AirWave®, Aruba Networks®, Aruba Mobility Management System®, Blugscanner, For Wireless That Works®, Mobile Edge Architecture, People Move, Networks Must Follow., RFPProtect®, The All Wireless Workplace Is Now Open For Business, and The Mobile Edge Company™ are trademarks of Aruba Networks, Inc. All rights reserved. All other trademarks are the property of their respective owners.

## Open Source Code

Certain Aruba products include Open Source software code developed by third parties, including software code subject to the GNU General Public License ("GPL"), GNU Lesser General Public License ("LGPL"), or other Open Source Licenses. The Open Source code used can be found at this site: [http://www.arubanetworks.com/open\\_source](http://www.arubanetworks.com/open_source)

## Legal Notice

The use of Aruba Networks, Inc. switching platforms and software, by all individuals or corporations, to terminate other vendors' VPN client devices constitutes complete acceptance of liability by that individual or corporation for this action and indemnifies, in full, Aruba Networks, Inc. from any and all legal actions that might be taken against it with respect to infringement of copyright on behalf of those vendors.

## Warranty

This hardware product is protected by the standard Aruba warranty of one year parts/labor. For more information, refer to the ARUBACARE SERVICE AND SUPPORT TERMS AND CONDITIONS. Altering this device (such as painting it) voids the warranty.



[www.arubanetworks.com](http://www.arubanetworks.com)  
1344 Crossman Avenue  
Sunnyvale, California 94089  
Phone: 408.227.4500  
Fax 408.227.4550

Aruba AP-103H Wireless Access Point | Installation Guide  
Part Number 0511618-01 | April 2014



0511618-01