



THURAYA Second-Generation User Terminal

SM-2500 Technical Information Manual

Document No.: AP01-601-08

**Asia Pacific Satellite Industries Co., Ltd
9FL, IT Castle 2-Dong, #550-1, Gasan-Dong, GeumCheon-Gu,
Seoul, Korea**

**Copyright © 2006 Asia Pacific Satellite Industries Co., Ltd
All Rights Reserved
APSI Proprietary**

**All information contained in or disclosed by this document is confidential and proprietary to APSI.
By accepting this material the recipient agrees that this material and the information contained
therein will be held in confidence and will not be reproduced in whole or in part without express
written permission from APSI.**

CONTENTS

1	INTRODUCTION	3
2	PIN DESCRIPTION	5
3	POWER SUPPLY.....	8
4	CONTROL SIGNALS.....	12
5	RTC BACKUP BATTERY INTERFACE.....	13
6	UART INTERFACE	13
7	USB INTERFACE.....	14
8	AUDIO INTERFACE.....	14
9	SIM CARD INTERFACE	14
10	LCD INTERFACE.....	15
11	BACKLIGHT INTERFACE	15
12	KEYPAD INTERFACE	15
17	MECHANICAL INTERFACE	16
18	HEAT DISSIPATION.....	18

1 Introduction

1.1 Scope

The purpose of this document is to explain the hardware technical information and specifications of SM-2500, Thuraya satellite module. This document will be helpful to third party designers and manufacturers.

For the AT command set of SM-2500, It will be dealt with another document. Please refer to the document number AP01-344-49, Thuraya Second Generation User Terminal AT Command Set.

1.2 Related documents

Table 1 Related documents

Document Number	Remark
AP01-344-49	Thuraya Second Generation User Terminal AT Command Set
ETSI TS 101 376-5-5	GMR-1 05.05, and GMPRS-1 05.05 Radio Transmission and Reception.

1.3 Terms and abbreviations

Table 2 Terms and abbreviations

Abbreviation	Description
SAT	Satellite.
GPS	Global Positioning System
PA	Power Amplifier
GMR	GEO Mobile Radio
RF	Radio Frequency
UART	Universal Asynchronous Receive and Transmitt
RTC	Real Time Clock

1.4 Overview

The Thuraya SM-2500 is a stand alone device which is able to access satellite mobile services via the GMR-1 and GMPRS-1 air interface, without additional components apart from the following: SAT antenna, GPS antenna, keypad, LCD, GSM Module, Bluetooth Module and battery / power supply.

The following Figure1 and Figure 2 shows the outline of SM-2500 and external interfaces that sat antenna RF connector, GPS antenna connector and 100 pins of board to board connector.

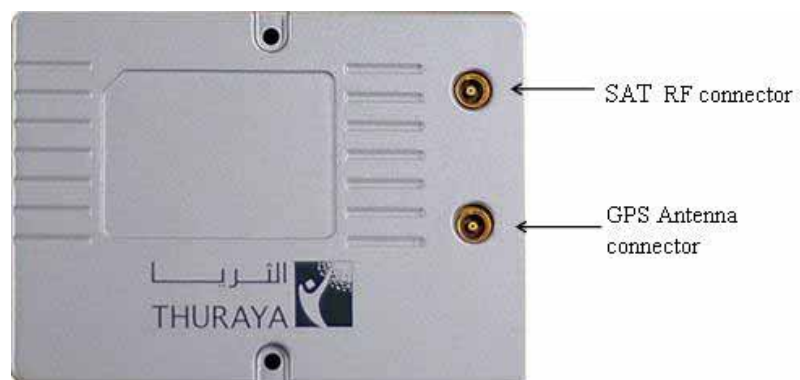

Figure 1 Top side

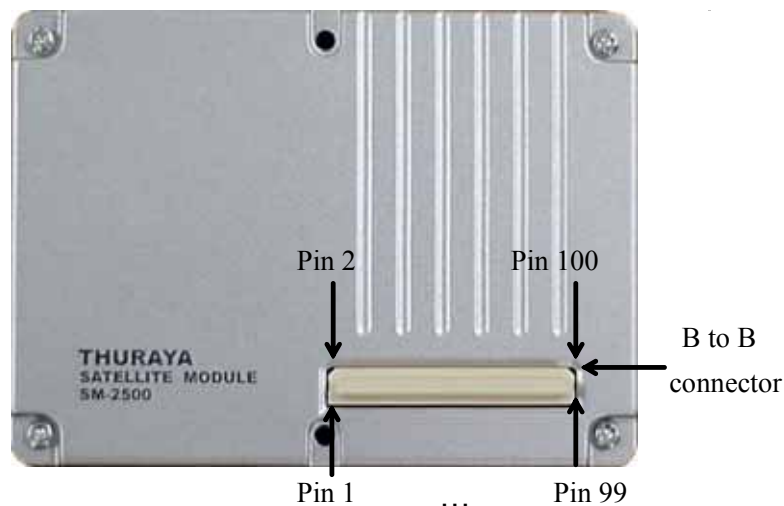

Figure 2 Bottom side

2 Pin description

SAT module has 100-pins B-to-B connector for interface with external device. Each pin, its designated function and interface is shown in Table 3 below.

Table 3 Pin functional and electrical description

PIN NAME	I/O	DESCRIPTION	ELECTRICAL SPEC.
VPWR	I	6 pin-allotted VPWR at board-to-board of SAT Module use as power and allowed input power is +3.2~4.5V. Supply max current: 300 mA (at 3.7, VEXT not used)	V _I max = +4.5V V _I min = +3.2V V _I typ = +3.7V
5V_TX	I	Pin-allotted 5V_TX at board-to-board of SAT Module use as input power of RF power amplifier and allowed input power is +4.8V~5.3V. This power has to be low ripple noise and enable to supply 1.5A (at 5V) of peak voltage well when TX transmit burst.	V _I max = +5.3 V V _I min = +4.8V V _I typ = +5.0V
VEXT	O	Power to supply external 3V. User can power off the module to prevent malfunction of module when this power exceed of allowed range. Prohibit approving external load of above 200 mA.	V _O max = +3.1V V _O min = +2.9V V _O typ = +3.0V I _{OL} max = 200 mA
LCD_D[0:7]	I/O	8bit bi-directional data bus for LCD data	V _{OH} min = 2.4V
/LCD_CS	O	LCD chip select output pin. Data/Instruction is enabled only when LCD_CS is low level.	V _{OL} max = 0.6V I _{OL} = 4 mA
/LCD_RD	O	Servers as a read strobe signal and read data at the low level.	V _{IH} min = 2.1V
/LCD_WR	O	Servers as a write strobe signal and write data at the low level.	V _{IL} max = 0.9V I _{IL} = 1 μA
LCD_RS	O	Data/Instruction select output pin H: LCD_D[0:7] are display data L: LCD_D[0:7] are instruction data	
LCD_EN	O	External LCD part power enable output pin. Active high	V _{OH} min = 2.5V V _{OL} max = 0.8V
/LCD_RESET	O	LCD reset output pin. When /LCD_RESET is low level, initialization is executed.	I _{OL} = 8 mA
LCD_BL_EN	O	White LED to backlight of LCD module enable pin. Active high	
LCD_DIM	O	White LCD to backlight of LCD module dimming control pin.	V _{OH} min = 2.4V V _{OL} max = 0.6V I _{OL} = 4 mA

KBR[00:04]	I	Row line input pin of keypad matrix.	$V_{IHmin} = 2.1V$ $V_{ILmax} = 0.9V$ $I_{IL} = 1 \mu A$
KBC[00:04]	O	Column line input pin of keypad matrix.	$V_{OHmin} = 2.4V$ $V_{OLmax} = 0.6V$ $I_{OL} = 4 mA$
KEYPAD_BL_EN	O	Keypad backlight enable output pin. Active high	$V_{OHmin} = 2.5V$ $V_{OLmax} = 0.8V$ $I_{OL} = 8 mA$
UART1_TXD	O	UART1 serial data output	See table 5 and table 6
UART1_RXD	I	UART1 serial data input.	
UART1_CTS	I	UART1 clear to send input.	
UART1_RTS	O	UART1 request to send output.	
UART1_DTR	O	UART1 data transmit ready output.	
UART1_DSR	I	UART1 data set ready input.	
UART1_DCD	O	UART1 data carrier detect output	
UART1_RI	O	UART1 ring indicator output.	
UART2_TXD	O	UART2 serial data output.	
UART2_RXD	I	UART2 serial data input.	
UART2_RTS	O	UART2 request to send output.	
UART2_CTS	I	UART2 clear to send input.	
I2C_SCL	O	I2C serial clock output.	
I2C_SDA	I/O	I2C serial bi-directional data.	
/I2C_INT	I	External I2C device detect and interrupt input.	$V_{IHmin} = 2.1V$ $V_{ILmax} = 0.9V$ $I_{IL} = 20 \mu A$
USB_VBUS	I	USB device detection input.	$V_{IHmin} = 3.0V$ $V_{ILmax} = 0.5V$ $I_{IL} = 10 \mu A$
USB_DP	I/O	USB data plus	$V_{IHmin} = 2.1V$ $V_{ILmax} = 0.75V$ $V_{OHmin} = 2.0V$ $V_{OLmax} = 0.8V$ $I_{OL} = 18.3 mA$
USB_DM	I/O	USB data minus	
GM_ON	I	Input pin to power SAT module on	$V_{IHmin} = 2.5V$ $V_{ILmax} = 0.5V$ $I_{IL} = 10 \mu A$

GM_OFF	I	Input pin that to power off the SAT module.	$V_{IHmin} = 2.1V$ $V_{ILmax} = 0.75V$ $I_{IL} = 2\text{ mA}$
/GM_RESET	I	Input pin to initialize SAT module. When boot up of SAT module, reset signal is generated by internal circuit to fit the processor reset timing, so it doesn't need to generate at external circuit. This pin has been pull-up 20 k Ω resistor. Thus, float if unused.	$V_{IHmin} = 2.1V$ $V_{ILmax} = 0.75V$ $I_d = 20\text{ mA}$
GM_STATUS	O	Output pin to inform a condition of SAT module to HOST.	$V_{OHmin} = 2.5V$ $V_{OLmax} = 0.8V$ $I_{OL} = 8\text{ mA}$
GM_WAKEUP	I	Input pin to wake SAT module up of sleep condition.	$V_{IHmin} = 2.1V$ $V_{ILmax} = 0.9V$ $I_{IL} = 20\text{ }\mu\text{A}$
HOST_WAKEUP	O	Output pin to wake SAT module up before sending data to HOST when HOST device is in sleep condition.	$V_{OHmin} = 2.4V$ $V_{OLmax} = 0.6V$ $I_{OL} = 4\text{ mA}$
GPIO1	I/O	General purpose I/O 1. User can control at command of user's own accord.	$V_{IHmin} = 2.0V$ $V_{ILmax} = 0.8V$ $I_{IL} = -1\text{ }\mu\text{A}$ $I_{IH} = 1\text{ }\mu\text{A}$
GPIO2	I/O	General purpose I/O 2. User can control at command of user's own accord.	$V_{OHmin} = 2.5V$ $V_{OLmax} = 0.8V$ $I_{OL} = 8\text{ mA}$
SIM_VDD	O	Supply voltage for SIM card.	1.8V SIM: $V_{min} = +1.71V$ $V_{max} = +1.89V$ $V_{typ} = +1.8V$ 3.0V SIM: $V_{min} = +2.8V$ $V_{max} = +3.2V$ $V_{typ} = +3.0V$ $I_{dtyp} = 50\text{ mA}(\text{max:}150\text{ mA})$
SIM_DATA	I/O	SIM card serial data.	1.8V SIM: $V_{IHmin} = 0.7 * \text{SIM_VDD}$ $V_{ILmax} = 0.4V$ $V_{OHmin} = 0.8 * \text{SIM_VDD}$ $V_{OLmin} = 0.4V$

			3.0V SIM: $V_{IHmin} = 0.7 * SIM_VDD$ $V_{ILmax} = 0.2 * SIM_VDD$ $V_{OHmin} = 0.8 * SIM_VDD$ $V_{OLmin} = 0.4V$
SIM_RST	O	SIM card reset.	1.8V SIM: $V_{OHmin} = 0.9 * SIM_VDD$ $V_{OLmax} = 0.2 * SIM_VDD$
SIM_CLK	O	SIM card serial clock.	3.0V SIM: $V_{OHmin} = 0.9 * SIM_VDD$ $V_{OLmax} = 0.4V$
VRTC	I	Backup power pin to supply power to interior RTC block when power is not supplied to module. This pin is used as voltage supply to fill up exterior battery when power is supplied to module.	$V_{INmax} = +5.5V$ $V_{INmin} = +2.0V$ $V_{INtyp} = +3V$ $I_{dd} = 15 \mu A (max)$
DAI_DIN	I	Input data for digital audio interface.	
DAI_DOUT	O	Output data for digital audio interface.	
DAI_CLK	O	Clock for digital audio interface.	
DAI_SYNC	O	Frame sync for digital audio interface.	
CODEC_SEL	I	Selects the internal or external PCM CODEC. H: external, L: internal	$V_{IHmin} = 2.0V$ $V_{ILmax} = 0.8V$ $I_{IL} = -1 \mu A$ $I_{IH} = 1 \mu A$
SPK+	O	Positive speaker output.	
SPK-	O	Negative speaker output.	
MIC+	I	Positive mic input.	
MIC-	I	Negative mic input.	
BUZZER	O	External buzzer control output.	$V_{OHmin} = 2.4V$ $V_{OLmax} = 0.6V$ $I_{OL} = 4 mA$
GND		Ground	

3 Power supply

The power supply of SAT module is composed as dual voltage source of VPWR (3.2V~4.5V) and

5V_TX (4.8V~5.3V). 5V_TX means providing power of internal power amplifier. And it is divided because it can be affect to the other circuit such as audio by outbreak of TDMA ripple noise, which is caused by peak current during TX burst.

5V_TX is supply power used at the intenal PA in the module, it is separated from VPWR, because the ripple in a transmit burst is

The ripple noise level of the power supply has to be limited to 50mV RMS in the 1MHz ~ 100MHz frequency range.

Required each of two power supplys specifications are described in follow.

3.1 VPWR

VPWR is main power source supplied at entire circuit except PA power in SAT module.

The supplied voltage range at VPWR is from 3.2V to 4.5V.

The internal ASIC in SAT module is detect voltage level of these pins.

If these pins are below 3.2V, module is power off, so when you design the power supply applications, it must be connted with the power source be able to provide sufficient current to rated 350mA

User can read to the voltage level of these pins as using AT command.

Power supply lines must be formatted to carry the rated 350mA(3.7V) current and kept short as possible to reduce lines impedance.

Bypass capacitors must be added to the power supply lines over 33 μ F MLCC (Multi-layer ceramic chip) or tantalum capacitor of low ESR for best input voltage filtering and minimizing the interference with other circuits caused by high input voltage spikes and small value ceramic capacitor in parallel beside of B-to-B connector as possible.

The value of the bypass capacitors can be increased without any limit for better input voltage filtering.

3.2 5V_TX

5V_TX is main power source for internal PA (power amplifier) in SAT module.

In some case, the ripple in a transmit burst may cause voltage drops when current consumption rises to typical peaks of 1.5A (5V), so the power supply must be able to provide sufficient current up to 1.5A.

These pins shouldn't be drops below 4.8V. If voltage of these pins is below 4.8V, module will not processing the call.

The best way to reducing voltage drops is using the low impedance power source including power supply lines and ESR value of the bypass capacitors.

We recommend that you use linear regulators what has low ripple noise and good transient response as source power.

5V_TX input capacitor depends on the impedance of the source supply and input power ripple.

To satisfy this high RMS current demand, two 150 μ F (10V) are required.

In parallel with these bulk capacitors, two 47 μ F (10V), low ESR (X5R) ceramic capacitors are added for HF noise reduction.

Power consumption timing diagrams is in figure 3 at talk time.

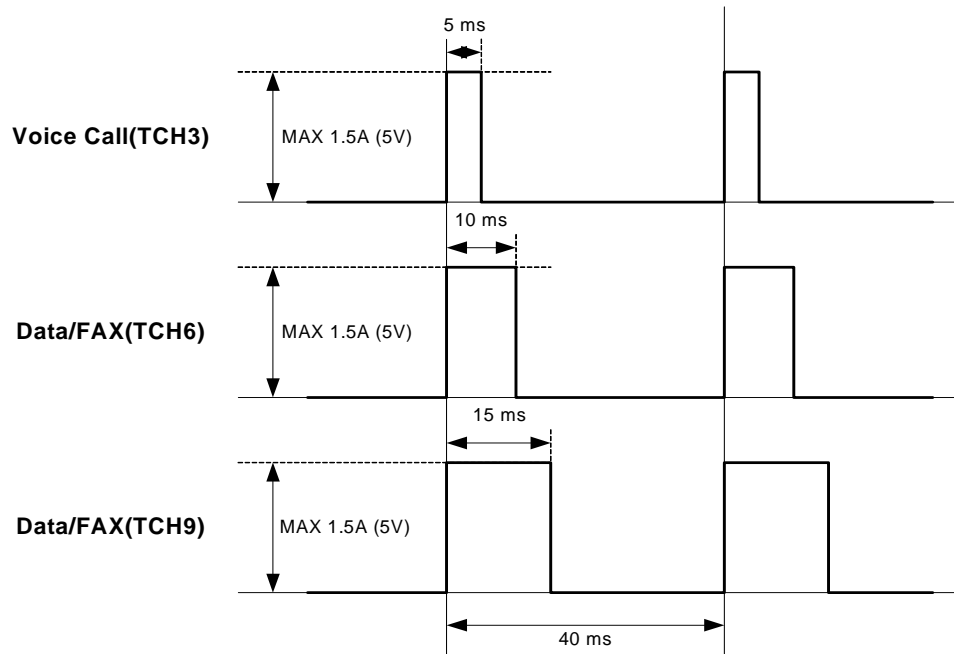

Figure 3 5V_TX timing diagrams on each talk mode

3.3 Power supply solutions of various application

User should select power device by regarding the following items as suiting to the character of each power when designs power supply.

1. Ripple noise should be ignorable
2. Transient response should be good quality
3. Whether output current enable to support enough current to each PIN
4. Whether accuracy is guaranteed
5. Whether PCB space suit to the condition required
6. Whether proper cost is required

There are some alternative devices for SAT module power supply solutions. The most common are described in below.

1. Linear voltage regulators (Section 5.3.1)
2. Switched DC/DC converter (Section 5.3.2)
3. 1-cell Li-Ion battery (Section 5.3.3)

3.3.1 Linear voltage regulators

Linear regulators has good quality of ripple noise and output accuracy, so power supply with linear regulators is easy to design, and the total cost for the components can be low, but efficiency is so bad

when the difference input voltage and output voltage is big.
 Ideally if the desired output voltage is 5V and the input voltage is 15V, ideal 10V goes away as heat, so efficiency is only 30%. Therefore linear voltage regulator is necessary to effective cooling element in case of big power dissipations.

We recomed linear voltage regulators only use when the difference input voltage and output voltage is below 1V

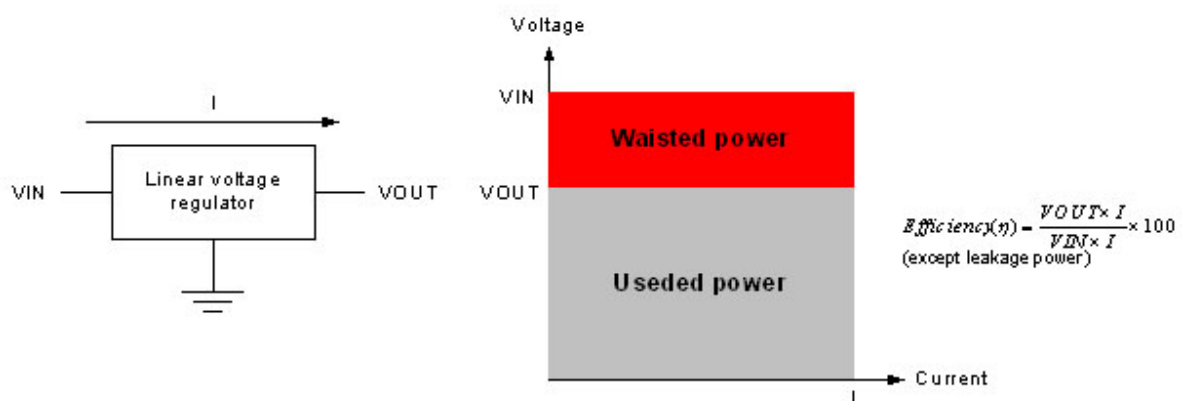

Figure 4 Ideally efficiency of linear voltage regurator

3.3.2 Switched DC/DC converter

A switched DC/DC converter is very often used when there are requirements for high efficiency. If you design the power supply what input voltage is above 15V and output voltage only is 5V, you need to the many cooling equipments because of a lot of heat. This problem can be resolved by using a switched DC/DC converter of high efficiency.

There are instead a lot of other things to consider when design with switched DC/DC converter.

1. Need to many parts of inductor, diode, big size capacitor etc.
2. PCB artwork must be very well because around a switched DC/DC converter there are magnetic fields, which can create disturbances to other electronic circuits.
3. Circuit is designed that it is suppressed the ripple noise created by switching of MOSFET.

3.3.3 Battery

1-cell Li-Ion battery is general power equipment which is mostly used at the handheld goods.

When using a Li-Ion battery the battery must be able to deliver all necessary power peaks to the SAT module.

The pack incorporates a protection circuit capable of detecting overvoltage (protection against overcharging), undervoltage (protection against deep discharging) and overcurrent. Overcurrent detecting range should be set as supply sufficient current

The internal resistance of the battery and the protection circuits should be as low as possible because internal resistance is very proportioned the voltage drop. It is recommended not to exceed 100mΩ, even under extreme conditions at low temperature.

The battery pack must be approved to satisfy the requirements of CE.

4 Control signals

There are 6-pins for control SAT module. It is pins for GM_ON, GM_OFF, /GM_RESET, GM_WAKEUP, HOST_WAKEUP, GM_STATUS, and HOST_STATUS.

The status of SAT module and HOST is shown in Figure 7 according to each of the control signals timing.

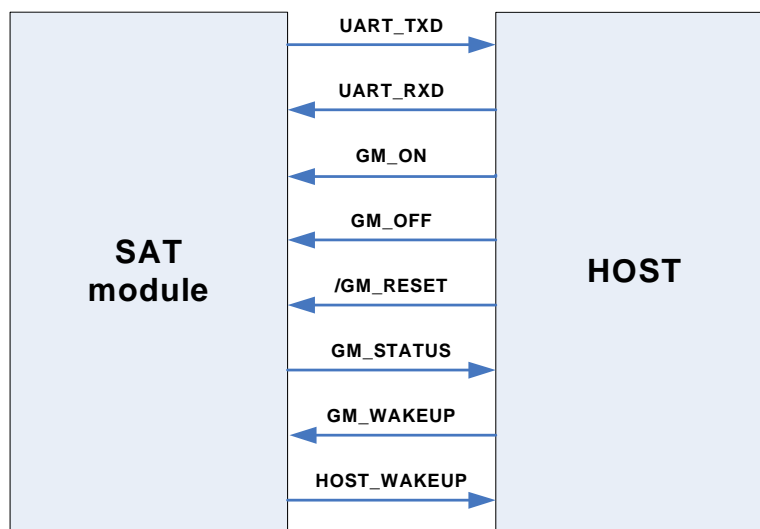

Figure .Connection diagram of control signals

5 RTC backup battery interface

RTC (Real Time Clock) power of SAT module is supplied by VRTC pin of board-to-board connector. VRTC is used power source of internal RTC block and GPS chipset.

External backup battery should be connected at VRTC pin because there's no supply of internal power in VRTC pin. When RTC backup battery is not used, it should be connected with VPWR or VEXT. Because, if this pin isn't connected with any power source, SAT module doesn't operate.

Electrical character of VRTC pin is as below.

$V_{max} = +5.5V$

$V_{min} = +2.0V$

$V_{norm} = +3V$

$I_{dd} = 15 \mu A$ (max)

6 UART interface

SAT module offers two UART ports. One provides 8-full-pins communications and the other one provides only 4 pins.

Driving current of each pin and voltage level of UART port are as follows.

Table 4 Max driving current of each UART pins

UART1	TXD	2	mA
	RXD	20	μA
	CTS	20	μA
	RTS	2	mA
	DSR	20	μA
	DTR	4	mA
	DCD	8	mA
	RI	8	mA
UART2	TXD	8	mA
	RXD	20	μA
	CTS	20	μA
	RTS	8	mA

Table 5 Logic level of UART port

	min	max	
Logic high input	2.1	3.3	V
Logic low input	0	0.9	V
Logic high output	2.4	3	V
Logic low output	0	0.6	V

7 USB interface

SAT module supports Revision 1.1 of Universal Serial Bus Specification.

8 AUDIO interface

8.1 CODEC selection

SAT module offers analog audio interface and digital audio interface.

Using or not of digital audio interface is decided by voltage level of CODEC_SEL pin.

If CODEC_SEL pin is 'high' level, then internal PCM CODEC is disabled and you can use external PCM CODEC. If CODEC_SEL pin is 'low' level, then internal PCM CODEC is used. If you make float CODEC_SEL pin, GEM module is using internal PCM CODEC.

When SAT module use internal PCM CODEC, you must make float DAI_DIN, DAI_DOUT, DAI_CLK, and DAI_SYNC pins.

The spec for a pin being 'High' must be stated – the voltage rise time etc.

8.2 Digital Audio Interface

SAT module supply DAI for various audio applications.

The digital audio interface consist of data input (DAI_DIN), data output (DAI_DOUT), clock output (DAI_CLK), and frame sync. (DAI_SYNC).

DAI_CLK : generated as 2.048MHz clock from SAT module.

DAI_SYNC : generated as 8kHz clock from SAT module.

DAI_DIN : received to 16-bits data from MSB bit to LSB bit at rising edge of clock.

DAI_DOUT: transmitted 16-bits data from MSB bit to LSB bit at rising edge of clock.

9 SIM card interface

SAT module requires a SIM card to operate in SAT mode (except for emergency call).

Support to the standard plug-in SIM card as defined in ETSI standard GSM 11.11, as modified by GSM 11.12. Both 1.8V/3.0V and 3.0V only SIM cards are supported.

Table .SIM card interface pins function description

SIM_VDD	SIM card power supply. 1.8V(MAX:±10%)/3V(MAX:±10%) SIM card auto detect, provided by SAT module.
SIM_CLK	SIM card clock, provided by SAT module.
SIM_RST	SIM card reset, provided by SAT module.
SIM_DATA	SIM card data line, input and output.

10 LCD interface

SAT module provides 14-pins interface with a LCD.

Specific characteristics are as below.

1. Supports 128*128 dot, 65k color LCD.
2. Using 8080-series 8bits parallel bus interface.
2. Supply LCD_EN for control main power of LCD.
4. Support LCD driver IC: S6B33B6

11 Backlight interface

3-pins are used to control backlight of keypad and LCD in SAT module.

Table .Backlight interface pins function description

LCD_BL_EN	LCD backlight enable (Active HIGH)
LCD_BL_DIM	LCD backlight dimming control (PWL signal output)
KEYPAD_BL_EN	KEYPAD backlight enable (Active HIGH)

12 Keypad interface

SAT module provides keypad interface of 5*5 matrix scan method.
 All of functions of module can be controlled by keypad.

13 Mechanical interface

The Figure 37 shows the mechanical interfaces of SM-2500 Recommended board to board female connector are also shown in Table 15. It's the recommended base in Figure 38.

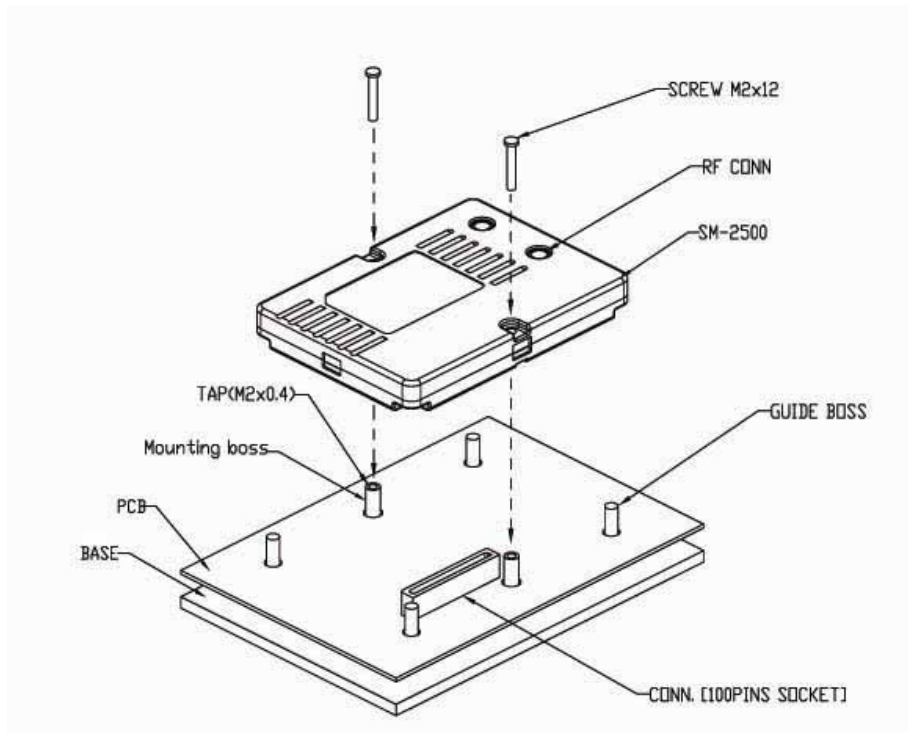

Mechanical interface

Recommended Board to Board Female connector

CONN. [100PINS, SOCKET]
 Mated height - 6.0mm, 6.5mm, 9.0mm type

Mated height	PART No. (Socket)	A	B	C	D
		Socket height	PCB to SM-2500	Guide boss height	Mounting boss height
6.0mm	AXK5S00045	3.05	2.9	3.8	
6.5mm	AXK5S00245	3.55	3.4	4.3	
9.0mm	AXK5S00340P	6.05	5.9	6.8	

(* Header : NAIS AXK6S00645P)

Figure .Recommended Base

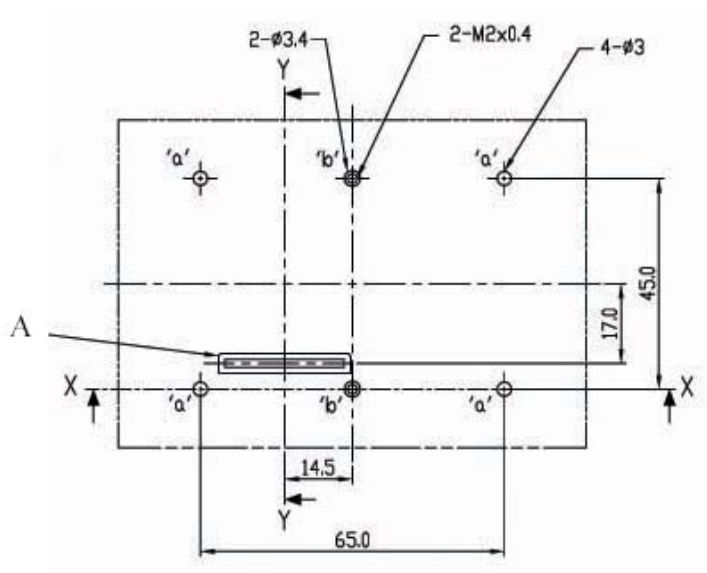

(A: CONN. [100PINS, SOCKET]
 Mated height-6.0mm, 6.5mm, 9.0mm type)

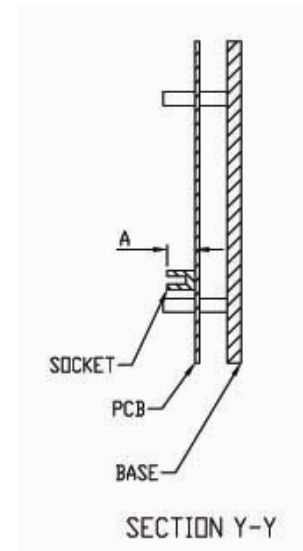
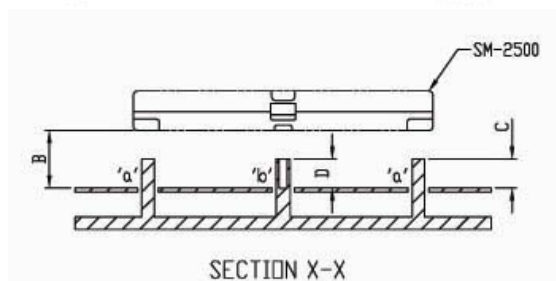

14 HEAT DISSIPATION

14.1 Installation method of Heat Sink

The proper method of heat dissipation to avoid overheating is necessary when SM-2500 is used in the closed space. Installation of HEAT SINK is recommended between PCB and SM-2500 as shown in the following figure.

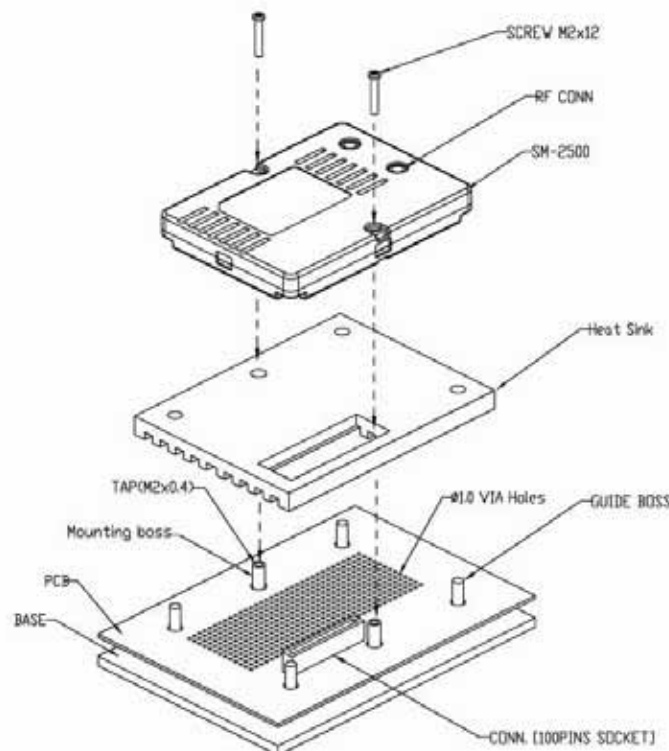

Figure 5 Installation method of Heat Sink

14.2 Guide of HEAT SINK and PCB design

The thickness of HEAT SINK should be changed depending on MATED HEIGHT as shown in the following figure.

The parts should not be located on the PCB surface including B2B connector contacting with Heat sink for SM-2500 and VIA hole during PCB design should be created on PCB as many as possible for good heat dissipation regarding the PCB area shown in the following figure.

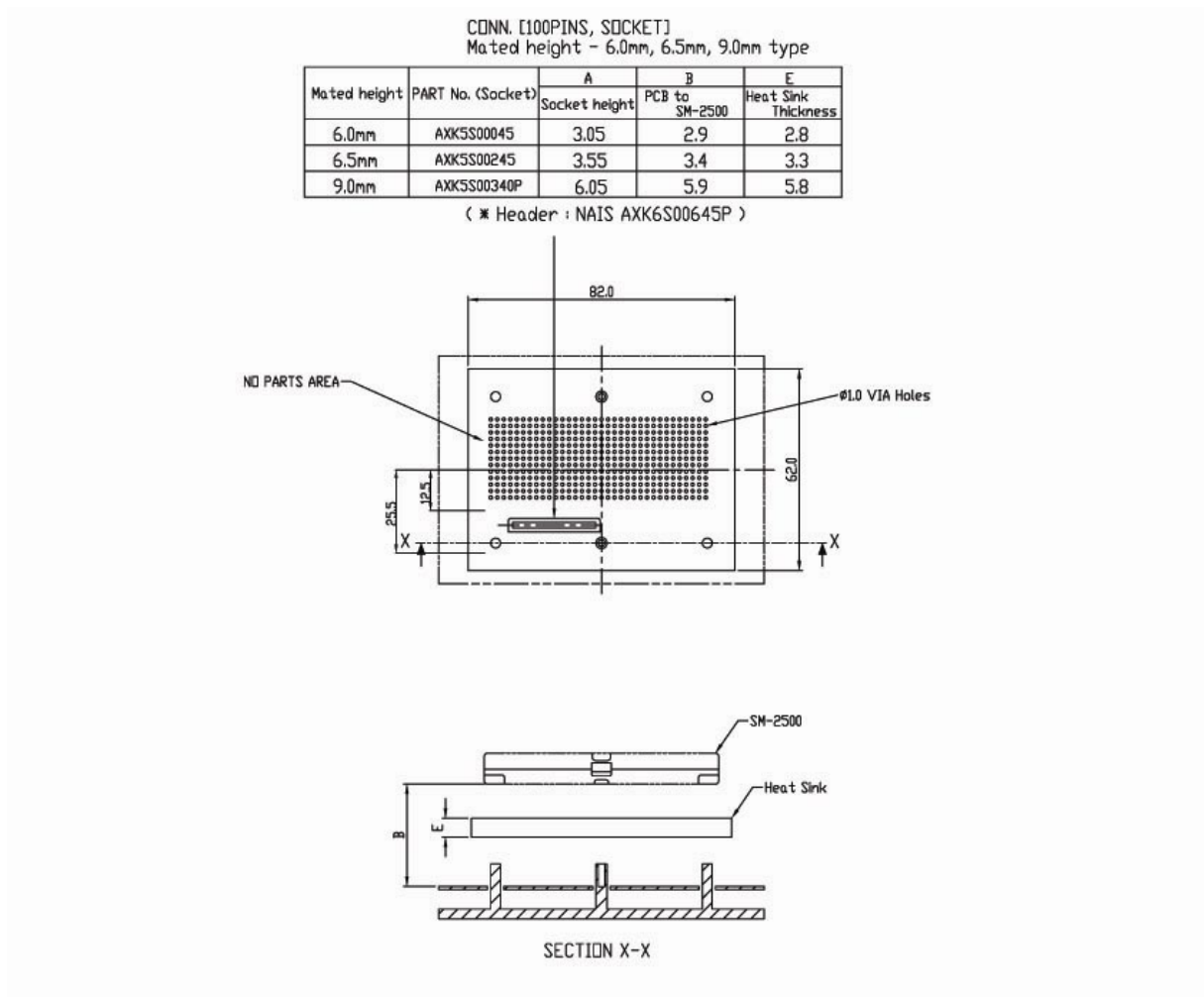

Figure .Guide of HEAT SINK and PCB design

The housing or case including SM-2500 and Heat Sink should be the material having good thermal conductivity such as Aluminum and keep a good thermal contact between SM-2500 and Heat Sink, and between the Heat Sink and outside housing.

14.3

The material like Aluminum which has good thermal conductivity should be used. The following figure is the example and size of heat sink for SM-2500.

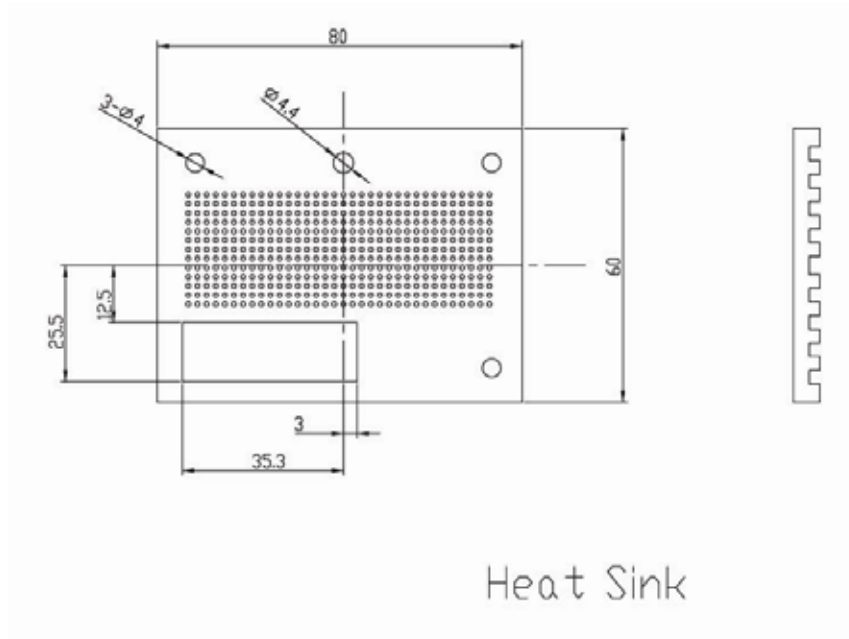

Figure .Example of HEAT SINK Design

15 Regulatory Information

15.1 NOTICES TO USER

This device complies with Part 15 of the FCC Rules. Operation is subject to the following two conditions:

(1) this device may not cause harmful interference, and (2) this device must accept any interference received, including interference that may cause undesired operation.

15.2 FCC WARNING

This equipment generates or uses radio frequency energy. Changes or modifications to this equipment may cause harmful interference unless the modifications are expressly approved by Asia Pacific Satellite Industries Co., Ltd. The user could lose the authority to operate this equipment if an unauthorized change or modification is made.

15.3 INFORMATION TO THE USER

This equipment has been tested and found to comply with the limits for a Class B digital device, pursuant to Part 15 of the FCC Rules.

These limits are designed to provide reasonable protection against harmful interference in a residential installation.

This equipment generates, uses and can generate radio frequency energy and, if not installed and

used in accordance with the instructions, may cause harmful interference to radio communications. However, there is no guarantee that the interference will not occur in a particular

installation. If this equipment does cause harmful interference to radio or television reception, which can be determined by turning the equipment off and on, the user is encouraged to try to correct the interference by one or more of the following measures:

- Reorient or relocate the receiving antenna.
- Increase the separation between the equipment and receiver.
- Connect the equipment to an outlet on a circuit different from that to which the receiver is connected.
- Consult the dealer for technical assistance.

IMPORTANT NOTE:

FCC Radiation Exposure Statement:

This equipment complies with FCC radiation exposure limits set forth for an uncontrolled environment. This equipment should be installed and operated with minimum distance of 20cm between the radiator and your body.

This transmitter must not be co-located or operating in conjunction with any other antenna or transmitter.