

ONE (1) YEAR LIMITED WARRANTY

Brookstone® warrants this product against defects in materials and/or workmanship under normal use for a period of ONE (1) YEAR from the date of purchase by the original purchaser ("Warranty Period"). If a defect arises and a valid claim is received within the Warranty Period, at its option, Brookstone will either 1) repair the defect at no charge, using new or refurbished replacement parts, or 2) replace the product with a new product that is at least functionally equivalent to the original product, or 3) provide a store credit in the amount of the purchase price of the original product. A replacement product or part, including a user-installable part installed in accordance with instructions provided by Brookstone, assumes the remaining warranty of the original product. When a product or part is exchanged, any replacement item becomes your property and the replaced item becomes Brookstone's property. When a store credit is given, the original product must be returned to Brookstone and becomes Brookstone's property.

Obtaining Service: To obtain warranty service, call Brookstone Limited Warranty Service at 1-800-292-9819. Please be prepared to describe the product that needs service and the nature of the problem. A purchase receipt is required. All repairs and replacements must be authorized in advance. Service options, parts availability and response times will vary. You are responsible for delivery and the cost of delivery of the product or any parts to the authorized service center for replacement, per our instructions.

Limits and Exclusions: Coverage under this Limited Warranty is limited to the United States of America, including the District of Columbia and the U.S. Territories of Guam, Puerto Rico, and the U.S. Virgin Islands. This Limited Warranty applies only to products manufactured for Brookstone that can be identified by the "Brookstone" trademark, trade name, or logo affixed to them or their packaging. The Limited Warranty does not apply to any non-Brookstone products. Manufacturers or suppliers other than Brookstone may provide their own warranties to the purchaser, but Brookstone, in so far as permitted by law, provides these products "as is." This warranty does not apply to: a) damage caused by failure to follow instructions relating to product's use or the installation of components; b) damage caused by accident, abuse, misuse, fire, floods, earthquake or other external causes; c) damage caused by service performed by anyone who is not a representative of Brookstone; d) accessories used in conjunction with a covered product; e) a product or part that has been modified to alter functionality or capability; f) items intended to be periodically replaced by the purchaser during the normal life of the product including, without limitation, batteries or light bulbs; g) any product sold "as is" including, without limitation, floor demonstration models and refurbished items; or h) a product that is used commercially or for a commercial purpose.

BROOKSTONE SHALL NOT BE LIABLE FOR INCIDENTAL OR CONSEQUENTIAL DAMAGES RESULTING FROM THE USE OF THIS PRODUCT, OR ARISING OUT OF ANY BREACH OF THIS WARRANTY. TO THE EXTENT PERMITTED BY APPLICABLE LAW, BROOKSTONE DISCLAIMS ANY AND ALL STATUTORY OR IMPLIED WARRANTIES, INCLUDING, WITHOUT LIMITATION, WARRANTIES OF MERCHANTABILITY, FITNESS FOR A PARTICULAR PURPOSE AND WARRANTIES AGAINST HIDDEN OR LATENT DEFECTS. IF BROOKSTONE CANNOT LAWFULLY DISCLAIM STATUTORY OR IMPLIED WARRANTIES, THEN TO THE EXTENT PERMITTED BY LAW, ALL SUCH WARRANTIES SHALL BE LIMITED IN DURATION TO THE DURATION OF THIS EXPRESS WARRANTY.

Some states disallow the exclusion or limitation of incidental or consequential damages or how long an implied warranty lasts, so the above exclusions or limitations may not apply to you. This warranty gives you specific legal rights and you may also have other rights, which vary from state to state.

Brookstone®

Cloud DSS Long-Range Copter

HOBBY-GRADE PERFORMANCE FOR SERIOUS OUTDOOR PILOTS



⚠ WARNING:

This product may contain small parts which may pose a choking hazard to children.

AGES
14+
AND UP

FLIGHT INSTRUCTION MANUAL







Thank you for purchasing the CLOUD DSS™ 2.4 G Wireless Outdoor Helicopter. Please read this instruction booklet as it contains valuable information on how to properly fly and care for your helicopter.

WARNING: Never leave product charging unattended for extended periods of time. Always disconnect helicopter from charger immediately after the helicopter is fully charged. Please refer to enclosed safety instructions.

Colors and styles may slightly vary

PART REPLACEMENT INSTRUCTIONS

CONTENTS:

(1) Propeller blade		x 2	(5) 2*8mm screws		x 4
(2) Tail propeller blade		x 1	(6) 2.3*5mm screws		x 1
(3) Direction connecting rods		x 2	(7) training head		x 1
(4) Connecting rods		x 2			

Cloud DSS PROPELLER SYSTEM

Your CLOUD DSS propeller system is a precision instrument that may need repair or replacement from time to time for optimal flight function. Crash landing from high-speed aerial flights may cause damage to your CLOUD DSS propeller or propeller connecting rods.

TROUBLESHOOTING:

If your CLOUD DSS loses its ability to fly correctly, please inspect the propeller system carefully for the following common issues:

1. Replacing Connecting Rod and Direction Connecting Rod: The connecting rod is a small "handcuff" style device that stabilizes the propellers. There are two connecting rods and two direction connecting rods on the propeller. Please see **Diagram 1**.

If a connecting rod or direction rod is broken or missing simply replace it by "peeling" off the existing broken unit and replacing it with a new one. You may have to use slight pressure when reattaching both ends of the new connecting rod. Make sure that the new connecting rod is secured and locked in place. See **Diagram 2**. For changing connecting rod, make sure there is no damage to the actual blade or arm that holds the connecting rod in place. If there is you must replace the entire blade system.

2. Replacing Propeller: The propeller is subject to damage as you learn to properly fly and control your CLOUD DSS. If after a crash your helicopter has loss of control or flies erratically you should carefully inspect your entire propeller system for any sign of damage. Most common are: cracked or chipped blade, broken "connecting rod," frozen balance bar (this is when the balancing bar and blade are jammed and can not move freely up and down). To replace the propeller blades follow diagrams 3 through 4.

3. Replacing Tail Propeller Blade: If after a crash your helicopter tail propeller blade is damaged, please replace it follow diagrams 5 through 6.

4. Interchanging the Head: Your CLOUD DSS package includes a Training head. It is highly recommended for users who are beginners to outdoor helicopters to practice initially with the Training head. It has been engineered using a more durable material and is more likely to withstand crashes. Please changing the head follow diagrams 7 through 10.

Replacing Connecting Rod and Direction Connecting Rod

Diagram 1

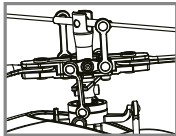

There are two propeller connecting rods on the propeller and two direction connecting rods.

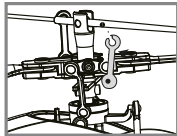

Broken connecting rod

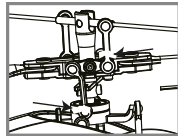

Broken connecting rod

Diagram 2

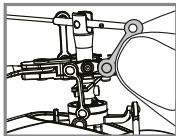

Replacing connecting rod

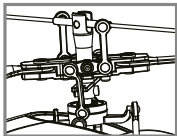

Proper connection

Replacing Damaged Propeller

Diagram 3



Using a Phillips screwdriver turn counter clockwise to remove the propeller screw.

Replacing Damaged Tail Propeller

Diagram 5



Using a Phillips screwdriver turn counter clockwise to remove the tail propeller screw.

Interchanging Training head

Diagram 7



Using a Phillips screwdriver turn counter clockwise to remove the head bottom screw.

Diagram 9



Disconnect the head light power cord on the new head and secure it by reversing the previous steps.

Diagram 4



Remove the broken blade and carefully replace with a new one, and then screw on.

Diagram 6



Remove the broken tail blade and carefully replace with a new one, and then screw on.

Diagram 8



Carefully snap off each side of the head from the bar.

Diagram 10



Connect the head light power cord on the new head and secure it by reversing the previous steps. (diagram 9-7)

TABLE OF CONTENTS

Features.....	2
Remote Control Battery Installation.....	2
Charging the Helicopter.....	2
Helicopter diagram, Remote diagram.....	3
Preparing for Flight.....	4
Syncing Your Helicopter.....	4
Flying Tips.....	4
Flight and Controls.....	5
Understanding Trim Adjustments.....	5
Servo Adjustments.....	6
Search Light and Body Light.....	6
Troubleshooting.....	6
Advanced Flight Controls.....	7
Helicopter Warning.....	8
Battery Warnings, Care and Maintenance.....	8
FCC Part 15 B Notice.....	8
Part Replacement Instructions.....	9
Contents.....	9
Cloud Dss Propeller System.....	9
Replacing connecting Rod and Direction Connecting Rod.....	9
Replacing Damaged Propeller Blade.....	10
Replacing Damaged Tail Propeller.....	10
Interchanging Training Head.....	10

FEATURES

- 2.4G long range wireless control
- Hobby grade fully interchangeable replacement parts
- Built-in gyroscopic chip for extreme stability and control
- High performance single blade rotor system for outdoor control
- 7.4v 650 mAh interchangeable battery
- Fly up, down, left, right, forward, backward and hover
- 1W Search light and multicolored LEDs can be turned ON/OFF from controller

REMOTE CONTROL BATTERY INSTALLATION

1. Pull the battery cover off of the remote control.
2. Install 8 "AA" alkaline batteries into the battery pack and then install the pack in the controller as shown in the diagram.
3. Replace the battery cover.

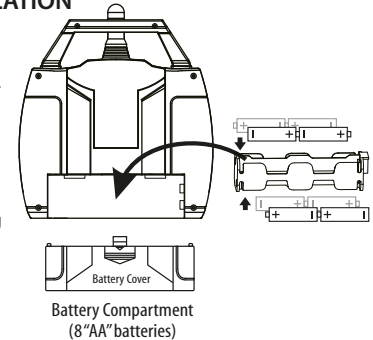

CHARGING THE HELICOPTER

1. Make sure the helicopter power switch is set to the OFF (left) position. All lights and propeller movement should be off.
2. Connect the charging socket on the wall charging adaptor to the charging connector on the underside of the helicopter. DO NOT FORCE THE CHARGING CONNECTOR(see diagram A)
3. Connect the adapter to the wall. The indicator light will illuminate in Red color to indicate charging in progress.
4. Length of charging time will vary depending on percentage of battery already charged. Average charging time is approximately 50-60 minutes. The helicopter operates for approximately 8-10 minutes per charge.
5. The charging indicator light will illuminate in Green color when the helicopter has been completely charged.

IMPORTANT: ALWAYS DISCONNECT CHARGER CORD AFTER CHARGING. NEVER LEAVE CHARGER CONNECTED TO HELICOPTER OVERNIGHT OR FOR EXTENDED PERIODS OF TIME.

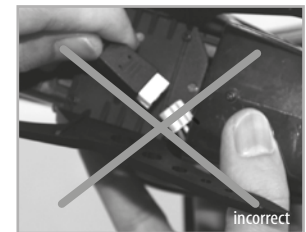
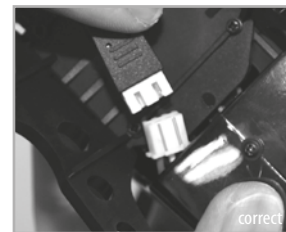

A

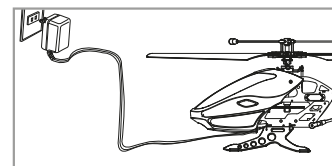

Charging socket is located on the underside of the helicopter. Wall charging cord connects as indicated. Red indicator light on charger stays on until charging is completed. When fully charged the indicator light on charger illuminates in green.

HELICOPTER DIAGRAM

Below is a basic list of features and parts on the helicopter.

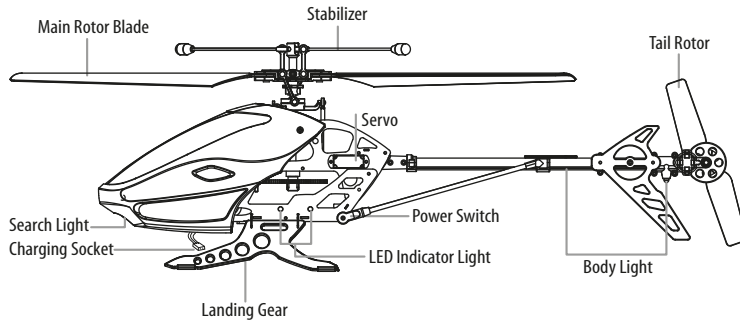

REMOTE DIAGRAM

Below is a basic list of features on the wireless remote control.

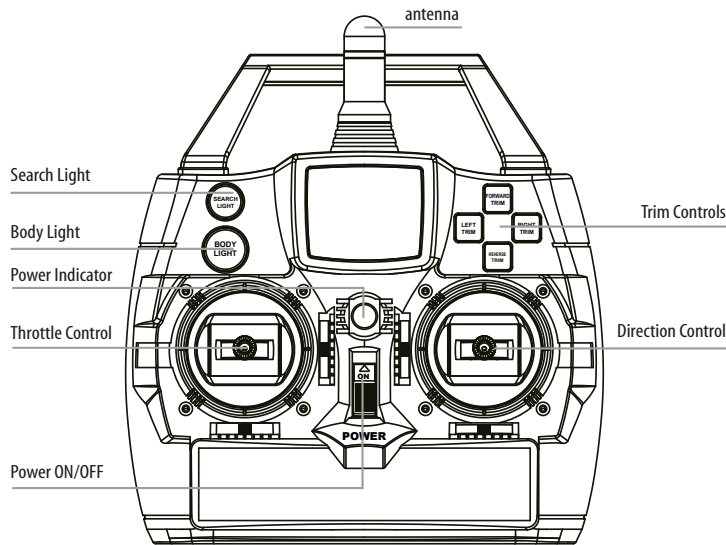

WARNING

DO NOT FLY YOUR CLOUD DSS IN FOUL WEATHER!



PREPARING FOR FLIGHT

- Verify that there are 8 "AA" batteries inside the remote control unit and the helicopter has been fully charged.
 - Make sure your helicopter and controller are turned on.
 - Make sure to be in a large space with an open radius of at least 50 feet.
 - Make sure the empty space has no obstacles and river. Set your helicopter on a clean flat surface before take-off.
- DO NOT ATTEMPT TO FLY YOUR CLOUD DSS IF THERE IS RAIN, SNOW, HEAVY WINDS, THUNDER OR LIGHTNING OUTDOORS. IT COULD DAMAGE YOUR PRODUCT AND POSSIBLY EVEN CAUSE BODILY HARM.**

SYNCING YOUR HELICOPTER

Your CLOUD DSS™ utilizes an automatic 2.4G channel selection system that allows up to 8 people to fly side by side in the same wireless range.

For One Person Play:

1. Before starting, make sure that the power on both your controller and helicopter are in the OFF position. Make sure that there are no other 2.4G devices in the area as well.
2. Turn ON the helicopter and set it down on a flat surface. The 2 LED indicators on each side of the body should blink in Red.
3. Turn ON your controller. The 2 LED indicators on each side of the body should now blink in a Red and Blue alternating fashion. This indicates that your product has been successfully synced. Should this not happen, repeat all steps again.

For Multi Person Play:

4. Before starting, make sure that the power on all Helicopters and Controllers are in the OFF position. Make sure that there are no other 2.4G devices in the area as well.
5. Each person will have to sync their helicopter individually at a different time to avoid interference. Follow steps 1 to 3 above making sure to keep away from other people while also making sure that no one else is syncing at the same time.
6. After syncing a player's helicopter, it should be left ON until all players have synced their helicopters.
7. Should there be a mistake/interference, all players must turn off their controllers and helicopters and start the process all over again.

Before Syncing, your Throttle should always be set to ZERO (All the way down). However, to prevent damage and injury, your helicopter has been fitted with a Safety Mechanism. After syncing your helicopter, a RED indicator light will flash on your controller in a slow pattern. Push the Throttle all the way up and the RED indicator light flashes faster. Pull back the Throttle all the way down and the RED indicator light will turn to a Solid Red. This indicates that you are ready to fly.

FLYING TIPS

- It is recommended that you operate the helicopter in a wide space. The ideal space should have a 200 foot radius. The helicopter is designed for OUTDOOR USE ONLY.
- Parental guidance or adult supervision is suggested at all times.
- If you are flying the helicopter with others, make sure all spectators are behind you.
- For best performance, it is recommended that you operate the helicopter in zero wind conditions. Wind can greatly affect the performance of the helicopter.

FLIGHT AND CONTROLS

Below is a list of basic flight functions on your wireless remote control and how they will affect your helicopter. While learning to fly your helicopter, it is best to start with a large space until you get used to the basic controls. As you master flying the helicopter you can move to more advanced maneuvering through the sky.

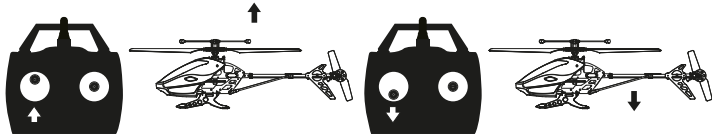

Move the Throttle up to increase the speed of the main rotor and the helicopter will rise up.

Move the Throttle down to decrease the speed of the main rotor and the helicopter will descend.

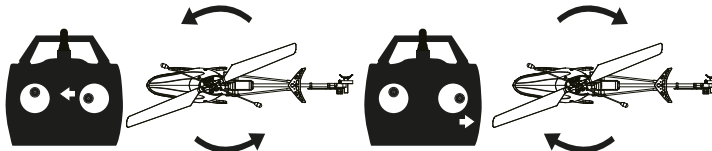

Move the Direction Control left and the helicopter will turn left.

Move the Direction Control right and the helicopter will turn right.

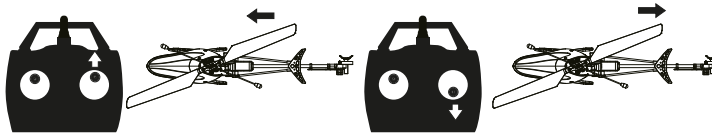

Move the Direction Control up and the helicopter will move forward.

Move the Direction Control down and the helicopter will move backward.

UNDERSTANDING TRIM ADJUSTMENTS

If your helicopter nose rotates to the left or right uncontrollably, you may need to utilize the TRIM buttons. If your helicopter over rotates CLOCKWISE (to the right), push and release the LEFT TRIM button repeatedly until the turning stops and proper flight is maintained. If your helicopter over rotates COUNTER-CLOCKWISE (to the left), push and release the RIGHT TRIM button repeatedly until the problem is resolved. From time to time you may have to adjust the left and right trim to ensure the helicopter will fly straight and respond accurately to control commands.

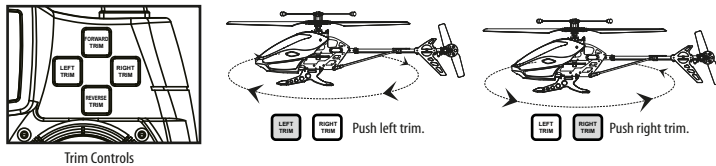

Trim Controls

NOTE: The use of the Trim buttons are accompanied with a Beep tone. A single long Beep indicates the product is center trimmed. Continuous long Beeps indicate the product is trimmed to the maximum or minimum on a particular side.

SERVO ADJUSTMENTS

If your helicopter is tilting or moving backwards while hovering or flying, push and release the FORWARD TRIM button repeatedly until the helicopter balances itself and stops leaning in a backward direction.

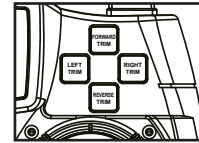

Trim Controls

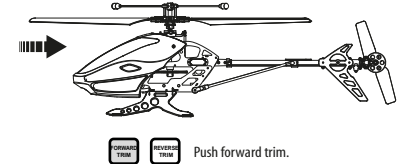

FORWARD TRIM REVERSE TRIM Push forward trim.

If your helicopter is tilting or moving forward while hovering or flying, push and release the REVERSE TRIM button repeatedly until the helicopter balances itself and stops leaning in a forward direction.

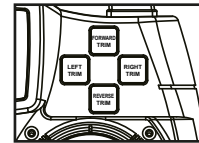

Trim Controls

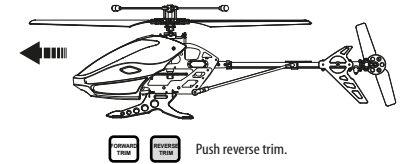

FORWARD TRIM REVERSE TRIM Push reverse trim.

SEARCH LIGHT AND BODY LIGHT BUTTONS

Press the SEARCH LIGHT button on the face of the controller (see CONTROLLER DIAGRAM) and your CLOUD DSS helicopter will light up the 1 W search light, Press the SEARCH LIGHT button a second time for a strobing effect.

Press the BODY LIGHT button on the face of the controller (see CONTROLLER DIAGRAM) to remotely switch the helicopter body lights OFF/ ON.

TROUBLESHOOTING

Before sending your helicopter in for repair, please check for a solution below.

Problem	Possible Cause(s)	Solution
Controller not responding	Weak Batteries; No Batteries	Install new batteries in controller
Helicopter does not respond properly to the controller	Either Helicopter or Controller are switched OFF Low Battery power in Helicopter or Controller Helicopter and Controller not properly synced	Switch ON both Controller and Helicopter Ensure Helicopter battery is fully charged and replace controller batteries Refer to the SYNCING YOUR HELICOPTER section
Helicopter loses connection with controller	Helicopter Out of Range Low Battery power in Helicopter or Controller	Fly Helicopter closer and within maximum range Ensure Helicopter battery is fully charged and replace controller batteries
Helicopter does not fly well	Helicopter not Trimmed Blade, Tail Rotor or other parts may be damaged Flying in Inclement Weather	Refer to Understanding Trim Adjustments and Servo Adjustments section Check and repair/replace damaged parts Stop flying and wait until the weather improves

ADVANCED FLIGHT CONTROLS

Once you have mastered the basic flight controls of your CLOUD DSS™ Helicopter it is time to try your hand at some more advanced flying techniques like forward and reverse sweeping turns.

1. To make a forward sweeping turn, first push the Direction Control stick all-the-way forward until the control stick touches the upper edge of the controller. (see Diagrams A and B, step 1 below). You should be moving straight forward at this point.
2. Secondly begin to slowly roll the Directional Control stick along the outer edge towards One O'Clock to sweep right or Counter-Clockwise along the outer edge towards Ten O'Clock to sweep left (see Advance Flight Maneuvers diagrams A and B below steps 1 and 2).
3. To do reverse sweeps simply reverse the Control Stick by moving first directly to the lower or backwards edge of the controller, then begin to roll the control stick slowly along the outer edge in the direction that you want the helicopter to sweep in reverse. Remember you must first have reverse momentum before attempting a sweep or you will simply turn in place.
4. Once you get familiar with flying your CLOUD DSS™ helicopter you can begin to fly higher and faster, making quicker turns and practicing new tricks.

ADVANCED FLIGHT MANEUVERS

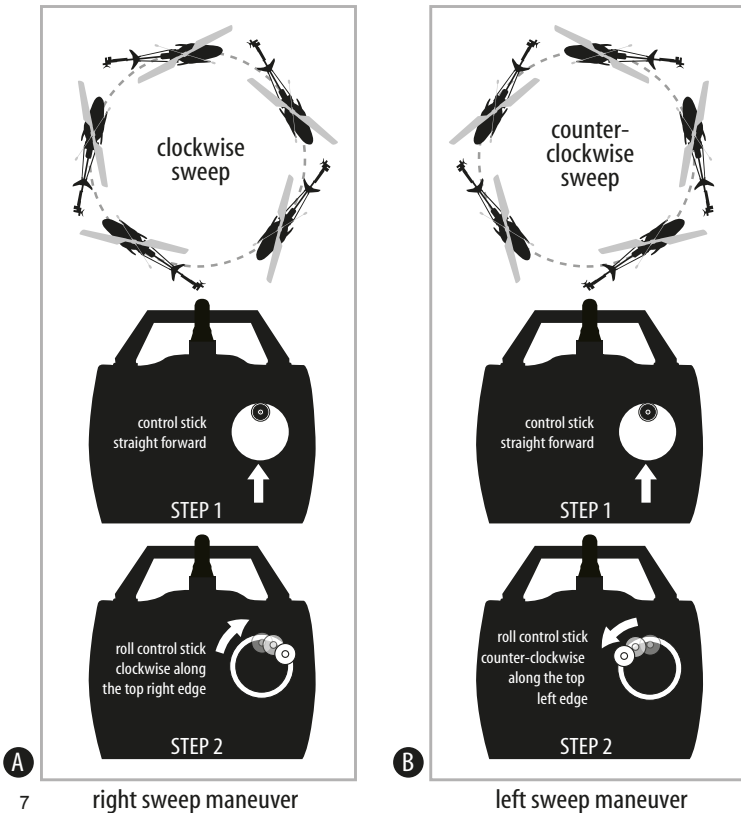

HELICOPTER WARNING:

The helicopter blades revolve at high speeds and can cause damage to the user, spectators and animals. Stand away from the helicopter to reduce the risk of getting into the flight path. Warn spectators that you will be flying your helicopter so that they are aware of its position. Before flight, inspect the rotor blades to make certain that the blades are securely fastened to the helicopter.

WARNING!

- Choking/Cutting Hazard. Small Parts/Sharp Rotor Blades.
- Keep hands, hair and loose clothing away from the propeller when the power switch is turned to the ON position.
- Turn off the transmitter and helicopter power switches when not in use.
- The remote control charger is built specifically for the helicopters Li-Poly battery. Do not use it to charge any other battery.
- New alkaline batteries are recommended for maximum performance.
- Parental supervision recommended when flying helicopter.

BATTERY WARNINGS

RECHARGEABLE BATTERY:

This helicopter uses an internal Li-Poly rechargeable battery. If battery no longer stays charged, dispose of battery properly according to local disposal requirements.

CONTROLLER BATTERIES:

Remote control requires 8"AA" batteries (not included). Please read the important battery safety warning below.

- Do not mix alkaline, standard (carbon-zinc) and rechargeable batteries (Nickel Metal Hydride).
- Do not mix old and new batteries.
- Non-rechargeable batteries are not to be recharged.
- Rechargeable batteries are to be removed from the item before being charged (if removable).
- Rechargeable batteries are only to be charged under adult supervision.
- Exhausted batteries should be removed immediately and must be recycled or disposed of properly according to state or local government ordinances and regulations.
- The supply terminals are not to be short-circuited.
- Only batteries of the same or equivalent type as recommended are to be used.
- Batteries are to be inserted with the correct polarity (see inside booklet for diagram).
- Do not dispose batteries in a fire- batteries may leak or explode.

CARE AND MAINTENANCE

- Always remove the batteries from the wireless infrared remote control when it is not being used for an extended period of time.
- To clean, gently wipe the remote control and helicopter with a clean damp cloth.
- Keep the toy away from direct heat or sunlight.
- Do not submerge the toy into water. This can damage the unit beyond repair.
- Parental guidance recommended when installing or replacing the batteries.

FCC Part 15 B Notice

CAUTION: Changes or modifications not expressly approved by the party responsible for compliance could void the user's authority to operate the equipment.

NOTE: This equipment has been tested and found to comply with the limits for a Class B digital device, pursuant to Part 15 of the FCC Rules. These limits are designed to provide reasonable protection against harmful interference in a residential installation. This equipment generates, uses and can radiate radio frequency energy and, if not installed and used in accordance with the instructions, may cause harmful interference to radio communications. However, there is no guarantee that interference will not occur in a particular installation. If this equipment does cause harmful interference to radio or television reception, which can be determined by turning the equipment off and on, the user is encouraged to try to correct the interference by one or more of the following measures:

- Reorient or relocate the receiving antenna.
 - Increase the separation between the equipment and receiver.
 - Connect the equipment into an outlet on a circuit different from that to which the receiver is connected.
 - Consult the dealer or experienced radio/TV technician for help.
- This device complies with Part 15 of the FCC Rules. Operation is subject to the following two conditions :

- (1) this device may not cause harmful interference, and
- (2) this device must accept any interference received, including interference that may cause undesired operation.