

SAFETY WARNINGS!

- Improper use of batteries may lead to overheating, breakage or leaking.
- Do not mix old and new batteries.
- Do not mix different battery brands.
- Install batteries with correct polarity. The flat side (negative terminal) of the battery should rest against the spring.
- Remove dead batteries immediately.
- Avoid liquids, which can short circuit the batteries.
- Never try to charge batteries that are not rechargeable.
- The vehicle or remote will become unresponsive when batteries are low, at which point you should replace all batteries with new ones.
- Remove the batteries if you will not use the vehicle for a long time.
- Avoid using near furniture or glass to prevent damage to these objects.
- Do not use vehicle on roads where real cars are in use, serious physical harm or death may result.
- Do not use vehicle in areas crowded with people as this may result in harm to vehicle and/or people, choose a safe location free of people and real cars.
- Do not use vehicle during a storm or when lightning and thunder are present.
- Do not use in a wet, sandy or muddy environment as vehicle may become damaged.
- Do not bend the antenna. It may break, exposing sharp metal that can cause injury.
- Do not pull on any wires that are part of the vehicle. Such action may cause the wires to break and the vehicle to malfunction.
- Keep fingers, hair and clothes away from the car's spinning tires. Failure to do so may result in physical injury.
- Never aim the vehicle at other people.
- Do not throw the vehicle or purposely hit it with any object.
- Store vehicle in a cool environment, away from high-temperature sources such as fires, stoves, radiators, etc.
- This vehicle has no user-serviceable parts. Do not attempt to modify components or circuit board.

CARE AND MAINTENANCE

- Remove the batteries from the transmitter when it is not used for extended periods of time.
- Gently wipe the controller and truck with a damp cloth to clean. Do not use soap or solvents as they can damage the surface.
- Keep the truck and transmitter away from direct heat or strong sunlight.
- Do not submerge the truck or transmitter into water, they will both be damaged beyond repair.
- Parental guidance is recommended when installing/replacing the batteries or charging.

FCC Part 15 B Notice

CAUTION: Changes or modifications not expressly approved by the party responsible for compliance could void the user's authority to operate the equipment.

NOTE: This equipment has been tested and found to comply with the limits for a Class B digital device, pursuant to part 15 of the FCC Rules. These limits are designed to provide reasonable protection against harmful interference in a residential installation. This equipment generates, uses and can radiate radio frequency energy and, if not installed and used in accordance with the instructions, may cause harmful interference to radio communications. However, there is no guarantee that interference will not occur in a particular installation. If this equipment does cause harmful interference to radio or television reception, which can be determined by turning the equipment off and on, the user is encouraged to try to correct the interference by one or more of the following measures:

- Reorient or relocate the receiving antenna.
- Increase the separation between the equipment and receiver.
- Connect the equipment into an outlet on a circuit different from that to which the receiver is connected.
- Consult the dealer or an experienced radio/TV technician for help.



Jeep® and the Jeep® grille design are registered trademarks of Chrysler Group LLC. Jeep® Rescue and its trade dress are used under license from Chrysler Group LLC. © Chrysler Group LLC 2010.

©2010 Rooftop Brands™ All rights reserved Patent Pending
Conforms to safety requirements ASTM, CPSIA and FCC.

Operation is subject to the following two conditions:
(1) this device may not cause interference, and
(2) this device must accept any interference, including interference that may cause undesired operation of the device.

Tel: + (1) 949-566-9573 • www.rooftopbrands.com



Jeep



OFF-ROAD RACERS RADIO CONTROL VEHICLE INTRODUCTION

Thank you for choosing Propel RC™ OFF-ROAD RACERS. Please read this instruction manual completely before using the product for the first time and keep this manual in handy for future reference.



Colors and styles may slightly vary.

FEATURES

- Radio-controlled 4X4 style monster truck for wireless driving action inside and outside
- Real working front and rear shocks
- Real working LED headlamps

SET-UP

1. Installing the batteries into the vehicle. Always use fresh batteries. Alkaline or rechargeable batteries are recommended for best performance.

Open the battery cover on the vehicle (see diagram A). Insert four (4) 1.5 V AA batteries (not included) into the battery components and replace the cover (see diagram B).

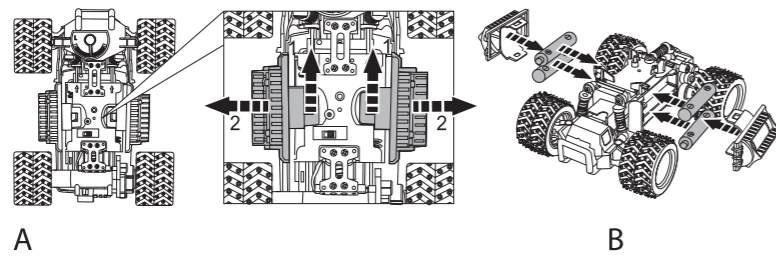

2. Installing the battery into the remote control.

Unscrew the safety screw on the battery cover and remove the battery cover (see diagram C). Insert one (1) 9V battery (not included) into the battery component, ensuring to match polarity and replace the battery cover.

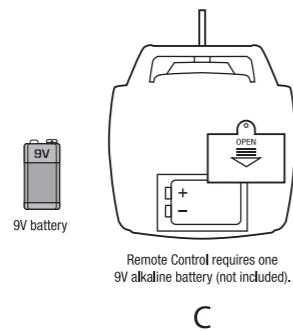

REMOTE CONTROL SPECIFICATIONS AND FUNCTIONS

1. Remote control functions:
- Forward straight
 - Forward left
 - Forward right
 - Backward straight
 - Backward left
 - Backward right
 - Stop

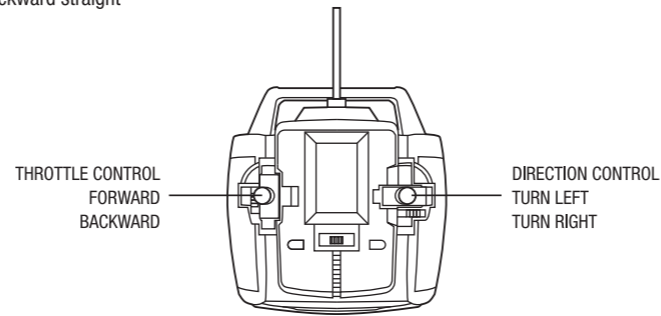

OPERATING YOUR OFF-ROAD RACER

Turn your vehicle on:

- Pick-up your vehicle and turn over the vehicle, so the under carriage is facing you. Make sure the batteries are properly installed and the battery compartment door is properly closed and locked.
- You will see an ON/OFF on the underside of the vehicle between the battery compartments. Move switch to the ON position and gently set the vehicle on the ground.

DRIVING YOUR VEHICLE

- Move the Throttle Control up to make the vehicle move forward.
- Move the Throttle Control down to make the vehicle move backward.
- Move the Direction Control left to turn the vehicle left.
- Move the Direction Control right to turn the vehicle right.
- To break or quickly stop simply pull or push the Throttle Control in the opposite direction.

WARNING
DO NOT USE YOUR VEHICLE IN FOUL WEATHER!



TROUBLESHOOTING

Prior to calling the help line, please check for a solution below.

Problem	Possible cause(s)	Solution
Vehicle will not move	weak batteries; no batteries	Install new batteries in remote control and in vehicle
Vehicle does not respond properly to remote control	Antenna missing or improperly installed Another RC vehicle may be transmitting on the same radio frequency	Refer to SETUP section to correctly install antenna Move to a new location where no other RC vehicle are present
Vehicle loses connection to remote control	Using vehicle in a small enclosed area Using vehicle indoors Antenna improperly installed Low batteries in transmitter or vehicle	Move outdoors to a large open area. Correctly install antenna. Install new batteries in remote control and in vehicle.
Vehicle has new batteries, but slower than normal	Driving vehicle for too long at high speeds, causing motor to overheat	Let vehicle sit still for 10-15 minutes