

FCC Part 15 B Notice

CAUTION: Changes or modifications not expressly approved by the party responsible for compliance could void the user's authority to operate the equipment.
NOTE: This equipment has been tested and found to comply with the limits for a Class B digital device, pursuant to Part 15 of the FCC Rules. These limits are designed to provide reasonable protection against harmful interference in a residential installation. This equipment generates, uses and can radiate radio frequency energy and, if not installed and used in accordance with the instructions, may cause harmful interference to radio communications. However, there is no guarantee that interference will not occur in a particular installation. If this equipment does cause harmful interference to radio or television reception, which can be determined by turning the equipment off and on, the user is encouraged to try to correct the interference by one or more of the following measures:
• Reorient or relocate the receiving antenna.
• Increase the separation between the equipment and receiver.
• Connect the equipment into an outlet on a circuit different from that to which the receiver is connected.
• Consult the dealer or experienced radio/TV technician for help.

This device complies with Part 15 of the FCC Rules. Operation is subject to the following two conditions:
(1) This device may not cause harmful interference, and
(2) This device must accept any interference received, including interference that may cause undesired operation.



Conforms to safety requirements of ASTM, CPSC and FCC.
©2015 Rooftop Brands™ All rights reserved
Tel: +1 949-566-9573 • www.propelrc.com

Made in China

Atom 1.0™ DRONE
2.4GHz Quadcopter



INSTRUCTION BOOKLET

WARNING: Never leave product charging unattended for extended periods of time. Always disconnect HD Sonic Drone from charger immediately after the HD Sonic Drone is fully charged. Please refer to enclosed safety instructions.

PACKAGE CONTAINS:

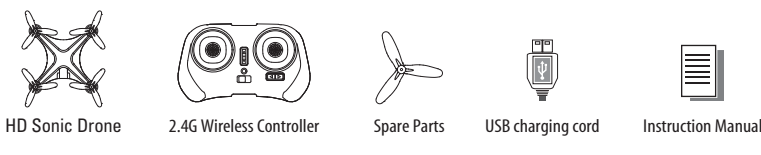

Colors and styles may slightly vary.

FEATURES

- 4 channel flight controls allow for incredible maneuverability including 360° aerial stunts!
- built-in auto gyro chip for extremely stable flight and maneuverability.
- digital radio allows flight range up to 20 meters.

REMOTE CONTROL BATTERY INSTALLATION

1. Unscrew the battery cover from the back of the controller as shown in diagram A.
2. Install 2 "AAA" alkaline batteries into the controller as shown in diagram B.
3. Replace the battery cover.
4. Turn over the controller and turn the on/off switch to the on position the red LED will flash if batteries are installed correctly.

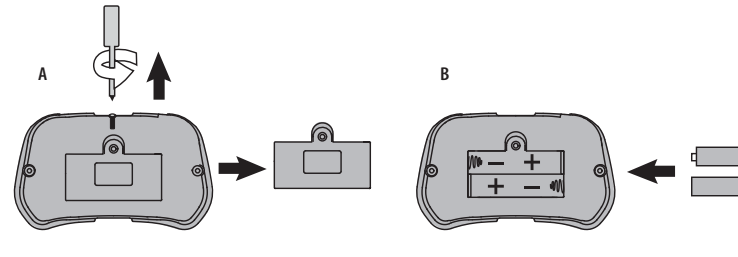

CHARGING YOUR Atom 1.0™ BATTERY

1. Switch the quadcopter off and connect the power cable to the unit making sure the arrow side of the connector is on top side facing the top of the Atom 1.0™ (see diagrams C1 and C2).
2. Connect the USB end of the cable to your computers USB port (see diagram D).
3. Average charging time is 25 minutes, the USB indicator light will glow red while the unit is charging. Remove promptly after the red LED turns off, the charge is now complete.
4. Turn over the controller and turn the on/off switch to the on position the red LED will flash if batteries are installed correctly.

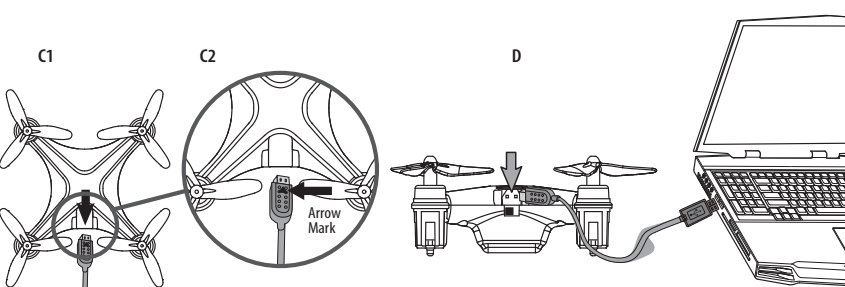

IMPORTANT: ALWAYS REMEMBER TO UNPLUG YOUR CHARGING CORD WHEN NOT IN USE!

TABLE OF CONTENTS

- Product Features 2
- Remote Control Battery Installation 2
- Charging Your Atom 1.0™ Battery 2
- Atom 1.0™ Quadcopter Diagram 3
- Remote Control Diagram 3
- Flight Preparation 4
- Syncing Your Atom 1.0™ 4
- Flying Tips 4
- Recognizing The Front & Back Of The Atom 1.0™ 5
- 4 Channel Flight Control 5
- Understanding Trim Adjustments 6
- Level Surface Calibration 6
- Low Battery Warning 6
- Switching The Flight Lever To The Left Control 7
- Switching To High Speed Mode 7
- Performing A 360° Stunt Roll 7
- Casting Off From Your Palm 8
- Trouble Shooting 9
- Replacing The Propeller Blades 9
- Warnings 10
- Battery Warnings 10
- Care and Maintenance 10
- FCC Information 11

Thank you for purchasing the Atom 1.0™ 2.4 GHz Mini Quadcopter. Please read this instruction booklet as it contains valuable information on how to properly fly and care for your Atom 1.0™ Drone.

RECOGNIZING THE FRONT & BACK OF THE Atom 1.0™

Even though the Atom 1.0™ has four rotors there is still a front or "forward" facing direction and "back" or backwards facing direction. The forward front and forward facing direction of the Atom 1.0™ is the side with two gray propellers (see diagram E). The rear and back of the Quadcopter is the side with two black propellers (see diagram E).
NOTE: The front of the Quadcopter displays RED LED lights and the back of the Quadcopter displays BLUE LED lights.

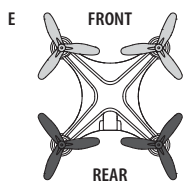

4 CHANNEL FLIGHT CONTROL

Below is a list of basic flight functions for your long-range remote control Atom 1.0™. While learning to fly your Atom 1.0™ it is best to start with a large space until you get used to the basic controls. As you master flying your Atom 1.0™ you can move to more advanced maneuvering techniques. Practice makes perfect! When you have these basic steps down you can move to the next level.

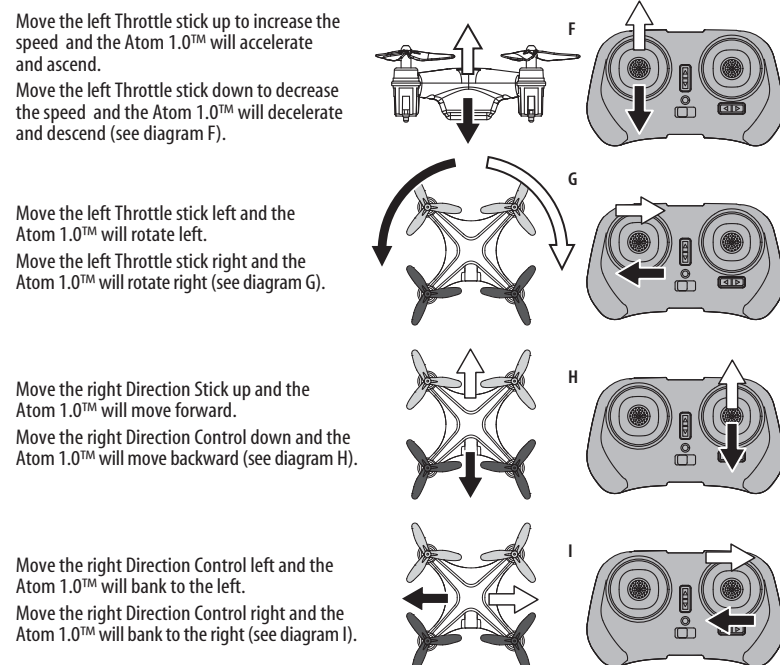

UNDERSTANDING TRIM ADJUSTMENTS

Forward/Backward Trim
• If your Atom 1.0 is drifting forwards or backwards, you may need to adjust the FORWARD/BACKWARD TRIM button (see diagram J).
• If your Atom 1.0 drifts left, push and release the BACKWARD TRIM button repeatedly until the motion stops and proper flight is maintained.
• If your Atom 1.0 drifts backwards, push and release the FORWARD TRIM button forward in the same manner until the problem is resolved.
• From time to time you may have to adjust the FORWARD or BACKWARD TRIM buttons to ensure the Atom 1.0™ will hover in mid-air and respond accurately to your commands.

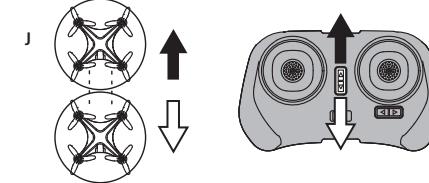

Right Left Trim
• If your Atom 1.0 is drifting left or right, you may need to adjust the LEFT/RIGHT TRIM button (see diagram K).
• If your Atom 1.0 drifts left, push and release the RIGHT TRIM button repeatedly until the motion stops and proper flight is maintained.
• If your Atom 1.0 drifts right, push and release the LEFT TRIM button in the same manner until the problem is resolved.
• From time to time you may have to adjust the LEFT or RIGHT TRIM buttons to ensure the Atom 1.0™ will hover in mid-air and respond accurately to your commands.

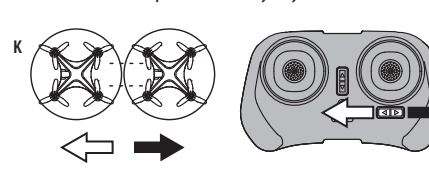

LEVEL SURFACE CALIBRATION

If the aircraft becomes unstable during the course of flying, you may need to recalibrate the internal gyros. To do this place the Atom 1.0™ on a level surface and pull both of the control levers on the remote down and to the left (approximately 45°) at the same time. The LEDs on the Atom 1.0™ will flash quickly and then remain solid, this indicates your aircraft has been stabilized (see diagram L).

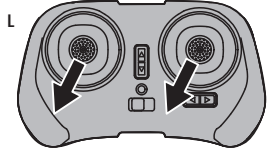

LOW BATTERY WARNING

If the power indicator LED on the remote lights up and emits an alert sound it means you are running at low voltage and need to land the aircraft slowly and safely and replace the batteries.
If the LED lights on the Atom 1.0™ begin flashing it means you are running at low voltage and you need to land the aircraft slowly and safely and recharge the aircraft.
WARNING: Do not attempt a 360° flip when you are given a low voltage warning

SWITCHING THE FLIGHT LEVER TO THE LEFT CONTROL

- To change the controls to the opposite side:
1. Turn the aircraft.
2. Press the control lever on the left side straight down while switching on the remote (see diagram M).
3. To switch the controls back, switch the remote off and back on.

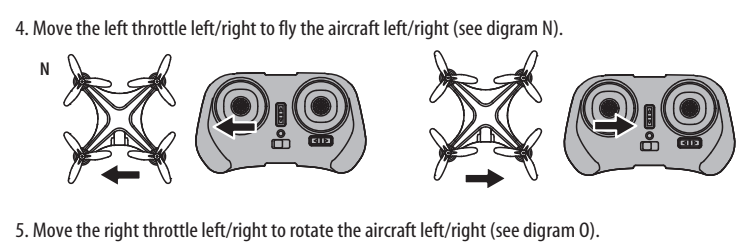
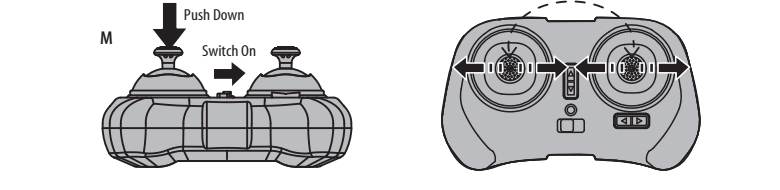

SWITCHING TO HIGH SPEED MODE

- To change the throttle speed from the default low speed to high speed:
1. Turn on the remote.
2. Press the control lever on the left side straight down to switch modes (see diagram P).
3. To switch back to low speed press the left control lever down again.
4. Speed mode returns to low speed once the remote is turned off.

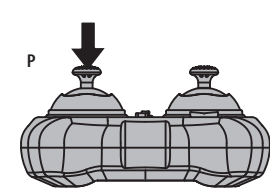

PERFORMING A 360° STUNT ROLL

- Once the Atom 1.0™ is airborne,
1. Press the right control lever straight down.
2. Move the lever in the direction you wish to perform the 360° roll (see diagram Q).

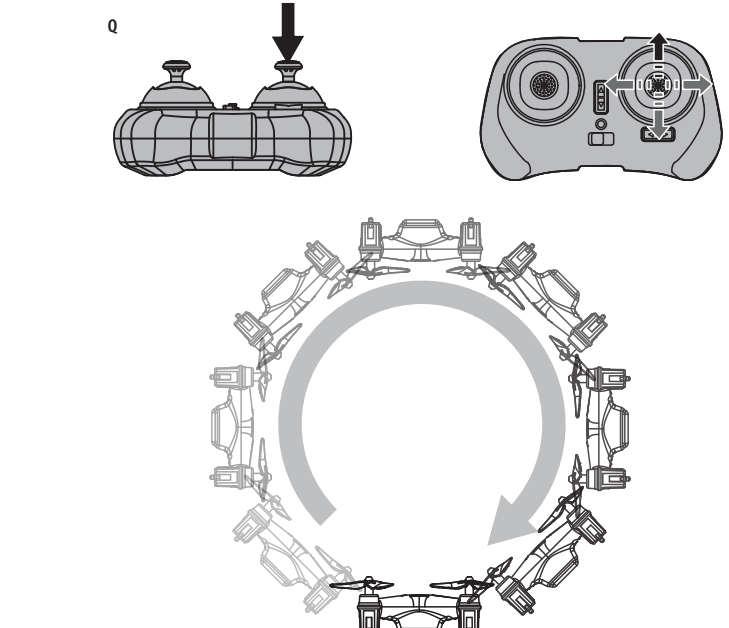

CASTING OFF FROM YOUR PALM

Place the Atom 1.0™ on your palm and gently toss it into the air as you engage the throttle.
CAUTION: Be careful not to touch the blades to avoid injury.



Atom 1.0™ QUADROPTER DIAGRAM

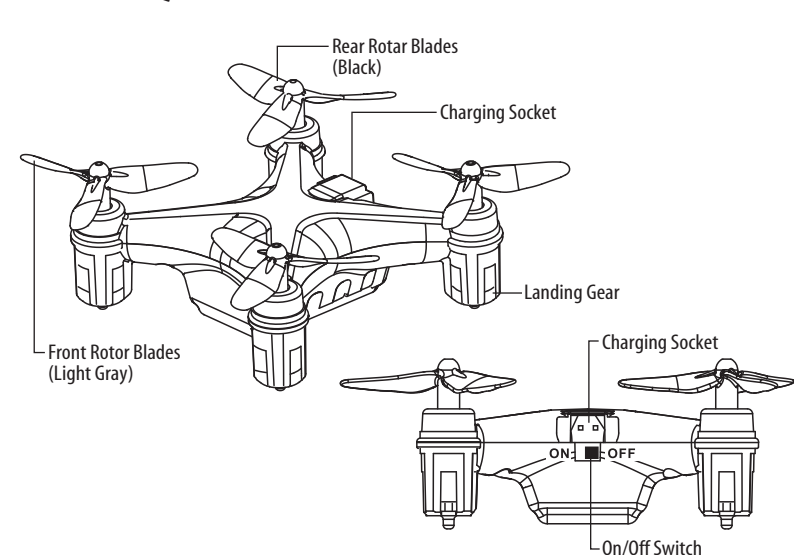

Atom 1.0™ REMOTE DIAGRAM

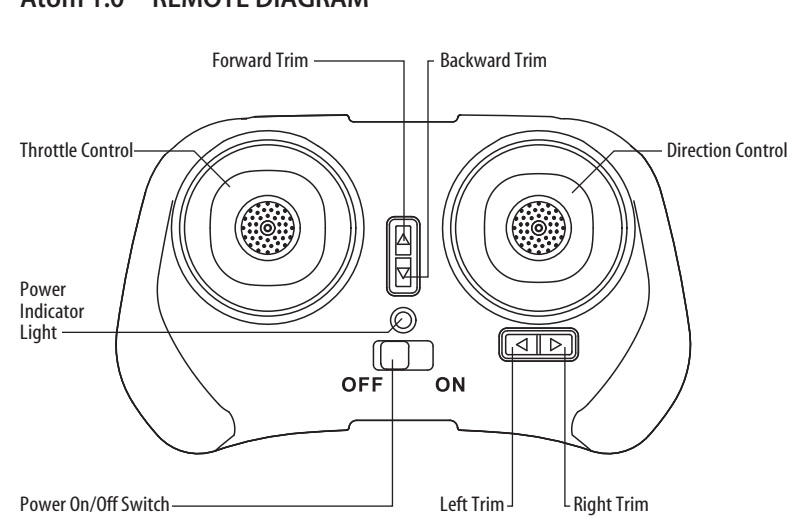

WARNING
DO NOT FLY YOUR Atom 1.0™ IN FOUL WEATHER!



FLIGHT PREPARATION

- Verify that there are 2 "AAA" batteries inside the remote control unit and the Atom 1.0™ has been fully charged.
- Make sure your Atom 1.0™ and controller are both turned on.
- Make sure to be in a large space with an open radius of at least 50 feet.
- Make sure the empty space has no obstacles and never set your Atom 1.0™ on a clean flat surface before take-off.

DO NOT ATTEMPT TO FLY YOUR Atom 1.0™ IF THERE IS RAIN, SNOW, HEAVY WINDS, THUNDER OR LIGHTNING OUTDOORS. IT COULD DAMAGE YOUR PRODUCT AND POSSIBLY EVEN CAUSE BODILY HARM.

SYNCING YOUR Atom 1.0™

Important! When syncing your ATOM1.0 quadcopter with the controller always make sure that the quadcopter is on a flat level surface and that your digital trim settings are in the center position. This ensures that the 6-axis gyro is properly programmed to mimic your trim settings. Your Atom 1.0™ utilizes an automatic 2.4G channel selection system that allows up to 8 people to fly side by side in the same wireless range with no interference.

- For One Person Fly:**
1. Before starting, make sure that the power on both your controller and Atom 1.0™ are in the OFF position. Make sure that there are no other 2.4G devices in the area as well.
 2. Turn ON the Atom 1.0™ and set it to hover on a flat surface. The LED indicator lights of the Atom 1.0™ should begin to flash.
 3. Turn ON the remote, you will hear long beeps, the Atom 1.0™ red LED lights should change to solid, push the throttle on the left all the way forward and then pull the throttle all the way back. Your controller and the helicopter should now be successfully synced, if not, repeat above steps again.
- For Multi Person Fly:**
4. Before starting, make sure that the power on all Atom 1.0™ Drones and Controllers are in the OFF position. Make sure that there are no other 2.4G devices in the area as well.
 5. Each person will have to sync their Atom 1.0™ individually at a different time to avoid interference. Follow steps 1 to 3 above making sure to keep away from other people while also making sure that no one else is syncing at the same time.
 6. After syncing a player's Atom 1.0™, it should be left ON until all players have synced their Atom 1.0™ Drone quadcopters.
 7. Should there be a mistake or interference, all players must turn off their controllers and Atom 1.0™ Drone Quadcopters for 60 seconds and then begin the process again.

FLYING TIPS

- It is recommended that you operate the Atom 1.0™ in a wide space. The ideal space should have a 200 foot radius.
- Parental guidance or adult supervision is suggested at all times.
- If you are flying the Atom 1.0™ with others, make sure spectators are behind you.
- For best performance, it is recommended that you operate the Atom 1.0™ in zero wind conditions. Wind can greatly affect the performance of the aircraft.

TROUBLESHOOTING YOUR ATOM1.0™

PROBLEM	POSSIBLE REASON	SOLUTION
NO POWER	1. Power switched off 2. Polarity is reversed 3. Batteries may be dead	1. Switch the ON/OFF switch to ON 2. Make sure all batteries are installed correctly (see diagram B) 3. Replace batteries
Remote Not Responding	1. Remote is switched off 2. Atom 1.0™ is switched off 3. Too windy 4. The Remote light is flashing	1. Switch the ON/OFF switch to ON 2. Switch the ON/OFF switch to ON 3. Windy conditions severely impair the operation of the Atom 1.0 4. Replace batteries
Aircraft Won't lift off	1. Rotor speed too slow 2. Aircraft not fully charged	1. Push throttle lever forward 2. Recharge your Atom 1.0™
Aircraft Descends Too Fast	1. Moving the throttle too quickly	1. Control the throttle slower and smoother
Aircraft Not Responding	1. Gyroscopes not functioning	1. Turn off the Atom 1.0™ and Reset the Gyro (see diagram L)
Loss of Atom 1.0™ Control	1. Aircraft is out of range of remote	1. Keep the aircraft within a 20 meter radius of the remote

REPLACING THE PROPELLER BLADES

Your Atom 1.0™ propeller system is a precision instrument that may need repair or replacement from time to time to optimize flight function. Crash landing from high-speed aerial flights may cause damage to your Atom 1.0™ propellers.
1. Atom 1.0™ have four blades, two gray propellers on the front, and two black propellers on the back. Please note that the blades and the Atom 1.0™ are labeled with an embossed L or R (see the diagram S).
2. When replacing the propeller blades, gently remove the blade from the rotor shaft. Make sure to match both the color of the blade and the indication letter on the blade with the letter on the aircraft.
3. Replace the damaged blade with the correct blade as shown in diagram S.

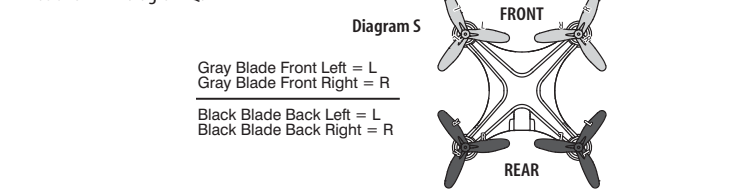

ATOM 1.0™ WARNING:

The Atom™ is designed for INDOOR or OUTDOOR. Atom™ blades revolve at high speeds and can cause damage to the user, spectators and animals. Stand away from the Atom 1.0™ to reduce the risk of getting into the flight path. Warn spectators that you will be flying your Atom 1.0™ so that they are aware of its position. Before flight, inspect the rotor blades to make certain that the blades are securely fastened to the Atom 1.0™.

WARNING

- Choking/Cutting Hazard. Small Parts/Sharp Rotor Blades.
- Keep hands, hair and loose clothing away from the propeller when the power switch is turned to the ON position.
- Turn off the transmitter and Atom™ power switches when not in use.
- The included charger is built specifically for the Atom™ Li-Poly battery. Do not use it to charge any other battery.
- New alkaline batteries are recommended for maximum performance.
- Parental supervision recommended when flying Atom™.

BATTERY WARNINGS

RECHARGEABLE BATTERY: This Atom™ uses a Li-Poly rechargeable battery. If battery no longer stays charged, dispose of battery properly according to local disposal requirements.

CONTROLLER BATTERIES: Remote control requires 2 "AAA" batteries (not included). Please read the important battery safety warning below.
• Do not mix alkaline, standard (carbon-zinc) and rechargeable batteries (Nickel Metal Hydride).
• Rechargeable batteries are not to be recharged.
• Rechargeable batteries are to be removed from the item before being charged (if removable).
• Rechargeable batteries are only to be charged under adult supervision.
• Exhausted batteries should be removed immediately and must be recycled or disposed of properly according to state or local government ordinances and regulations.
• The supply terminals are not to be short-circuited.
• Only batteries of the same or equivalent type as recommended are to be used.
• Batteries are to be inserted with the correct polarity (see inside booklet for diagram).
• Do not dispose batteries in a fire - batteries may leak or explode.

CARE AND MAINTENANCE

- Always remove the batteries from the wireless infrared remote control when it is not being used for an extended period of time.
- Be clean, gently wipe the remote control and Atom™ with a clean damp cloth.
- Keep the toy away from direct heat or sunlight.
- Do not submerge the toy into water. This can damage the unit beyond repair.
- Parental guidance recommended when installing or replacing the batteries.