

FCC Part 15 C Notice

CAUTION: Changes or modifications not expressly approved by the party responsible for compliance could void the user's authority to operate the equipment.

NOTE: This equipment has been tested and found to comply with the limits for a Class B digital device, pursuant to Part 15 of the FCC Rules. These limits are designed to provide reasonable protection against harmful interference in a residential installation. This equipment generates, uses and can radiate radio frequency energy and, if not installed and used in accordance with the instructions, may cause harmful interference to radio communications. However, there is no guarantee that interference will not occur in a particular installation. If this equipment does cause harmful interference to radio or television reception, which can be determined by turning the equipment off and on, the user is encouraged to try to correct the interference by one or more of the following measures:

- Reorient or relocate the receiving antenna.
- Increase the separation between the equipment and receiver.
- Connect the equipment into an outlet on a circuit different from that to which the receiver is connected.
- Consult the dealer or experienced radio/TV technician for help.

This device complies with Part 15 of the FCC Rules. Operation is subject to the following two conditions :

- (1) This device may not cause harmful interference, and
- (2) this device must accept any interference received, including interference that may cause undesired operation.

INDUSTRY CANADA NOTICE: CANADA ONLY.

This device complies with Industry Canada licence-exempt RSS standard(s). Operation is subject to the following two conditions: (1) this device may not cause interference, and (2) this device must accept any interference, including interference that may cause undesired operation of the device.

Le présent appareil est conforme aux CNR d'Industrie Canada applicables aux appareils radio exempts de licence. L'exploitation est autorisée aux deux conditions suivantes : (1) l'appareil ne doit pas produire de brouillage, et (2) l'utilisateur de l'appareil doit accepter tout brouillage radioélectrique subi, même si le brouillage est susceptible d'en compromettre le fonctionnement.



Conforms to safety requirements of FCC.

©2016 Rooftop Brands™ All rights reserved
Tel: + (1) 949-566-9573 • www.propelrc.com

Made in China

ORBIT™ HD

2.4GHz Quadcopter With HD Camera



INSTRUCTION BOOKLET

WARNING: Never leave product charging unattended for extended periods of time. Always disconnect ORBIT™ HD battery from charger immediately after it is fully charged. Please refer to enclosed safety instructions.

PACKAGE CONTAINS:



Colors and styles may slightly vary.

TABLE OF CONTENTS

Product Features.....	2
Remote Control Battery Installation.....	2
Charging Your ORBIT™ HD Battery.....	2
ORBIT™ HD Quadcopter Diagram.....	3
Remote Control Diagram.....	3
Remote LCD Diagram.....	3
Flight Preparation.....	4
Syncing Your ORBIT™ HD.....	4
Flying Tips.....	4
How To Start/ Stop Rotors.....	5
Auto Start/Land Button.....	5
Recognizing The Front & Back Of The ORBIT™ HD.....	5
4 Channel Flight Control.....	5
Adjusting Trim.....	6
Level Surface Calibration.....	6
Flight Environment.....	7
Flight Practice.....	7
Performing a 360° Stunt Flip.....	7
Trouble Shooting.....	8
Attaching Camera.....	8
Replacing The Propeller Blades.....	9
Warnings.....	10
Battery Warnings.....	10
Care and Maintenance.....	10
FCC Information.....	11

Thank you for purchasing the ORBIT™ HD 2.4 Ghz Quadcopter. Please read this instruction booklet as it contains valuable information on how to properly fly and care for your ORBIT™ HD Drone.

FEATURES

- 6 Axis Gyro For Extremely Stable Flight and Maneuverability
- Wide Range Digital Radio Allows Flight Range Up To 500 Feet
- 3 Speed Settings From Beginner To Advanced Pilots
- 360 Degree Push Button Stunt Rolls
- Air pressure sensors lock flight altitude for stable video footage
- Automatically lands with the push of a button
- 2.4 Ghz Controller, Replaceable Li-poly Battery and Additional Replacement Parts Included.

REMOTE CONTROL BATTERY INSTALLATION

1. Remove the battery cover from the back of the controller as shown in diagram A.
2. Install 6 "AA" fresh alkaline batteries into the controller as shown in diagram B. Make sure to install batteries to their correct polarity. Do not mix old and new batteries or battery types.
3. Replace the battery cover.

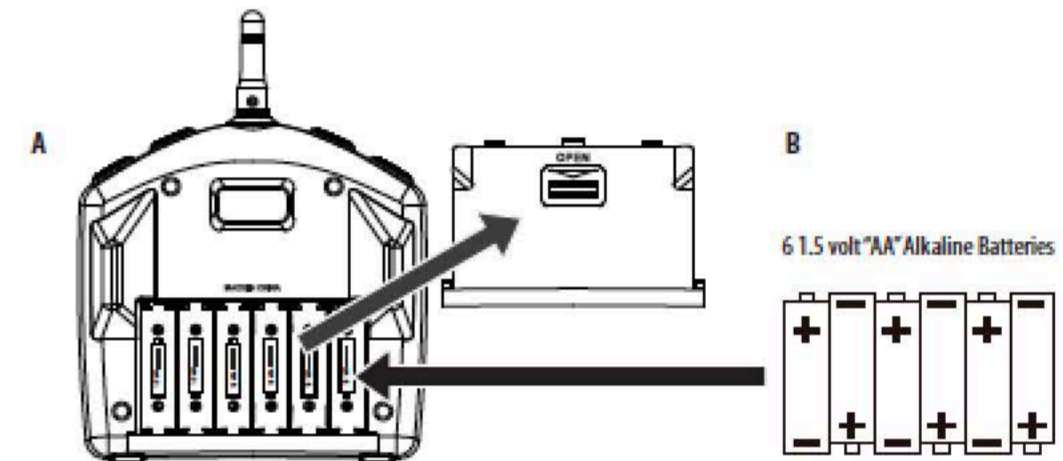

CHARGING YOUR ORBIT™ HD Li-POLY BATTERY

1. Slide the battery into the USB charger and then connect the MICRO USB cable to the charger (see diagram C). Connect the universal end of the USB cable to your computer's USB port.
CAUTION: Do not force battery into charger, improper connection may damage the ORBIT™ HD battery.
2. The indicator light will flash red while the unit is charging. When the RED Led light turns GREEN your battery has a complete charge.
3. Average charging time is around 50 minutes until fully charged.
4. A full charge will allow for about 7-10 minutes of flight time depending on environment and user input.

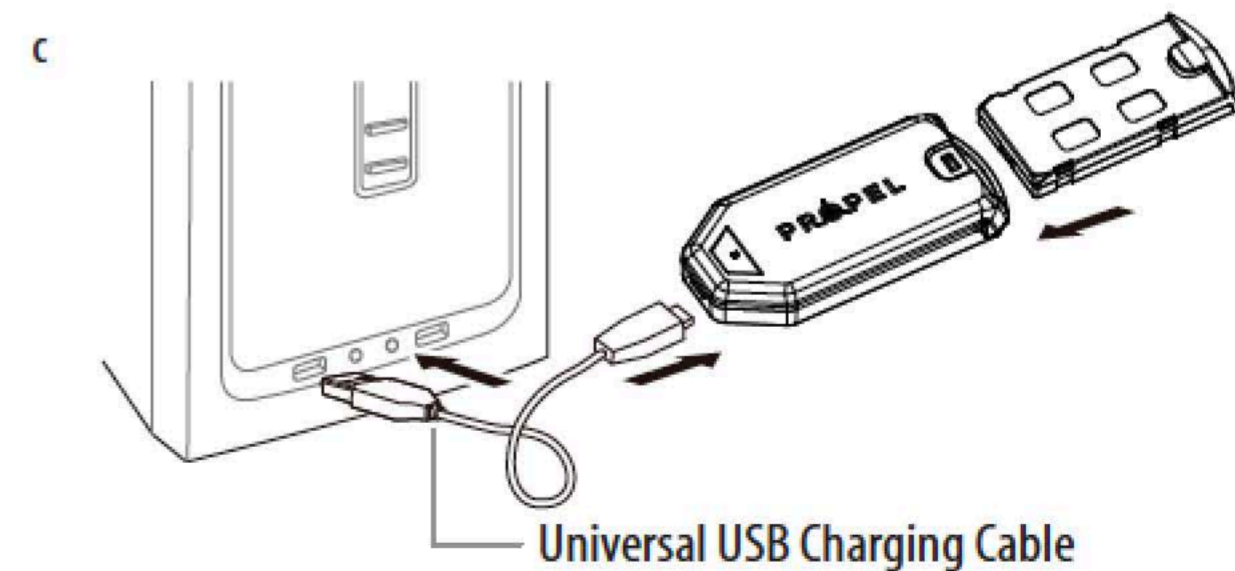

IMPORTANT: ALWAYS REMEMBER TO UNPLUG YOUR CHARGING CORD WHEN NOT IN USE!

ORBIT™ HD QUADROCOPTER DIAGRAM

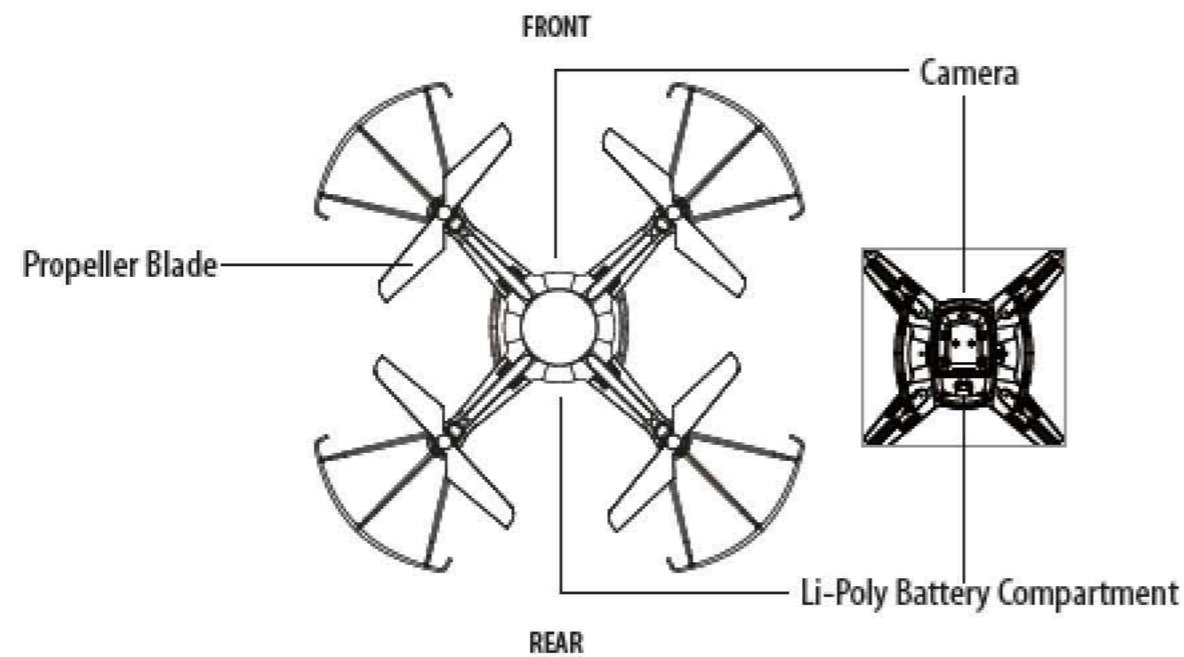

ORBIT™ HD REMOTE DIAGRAM

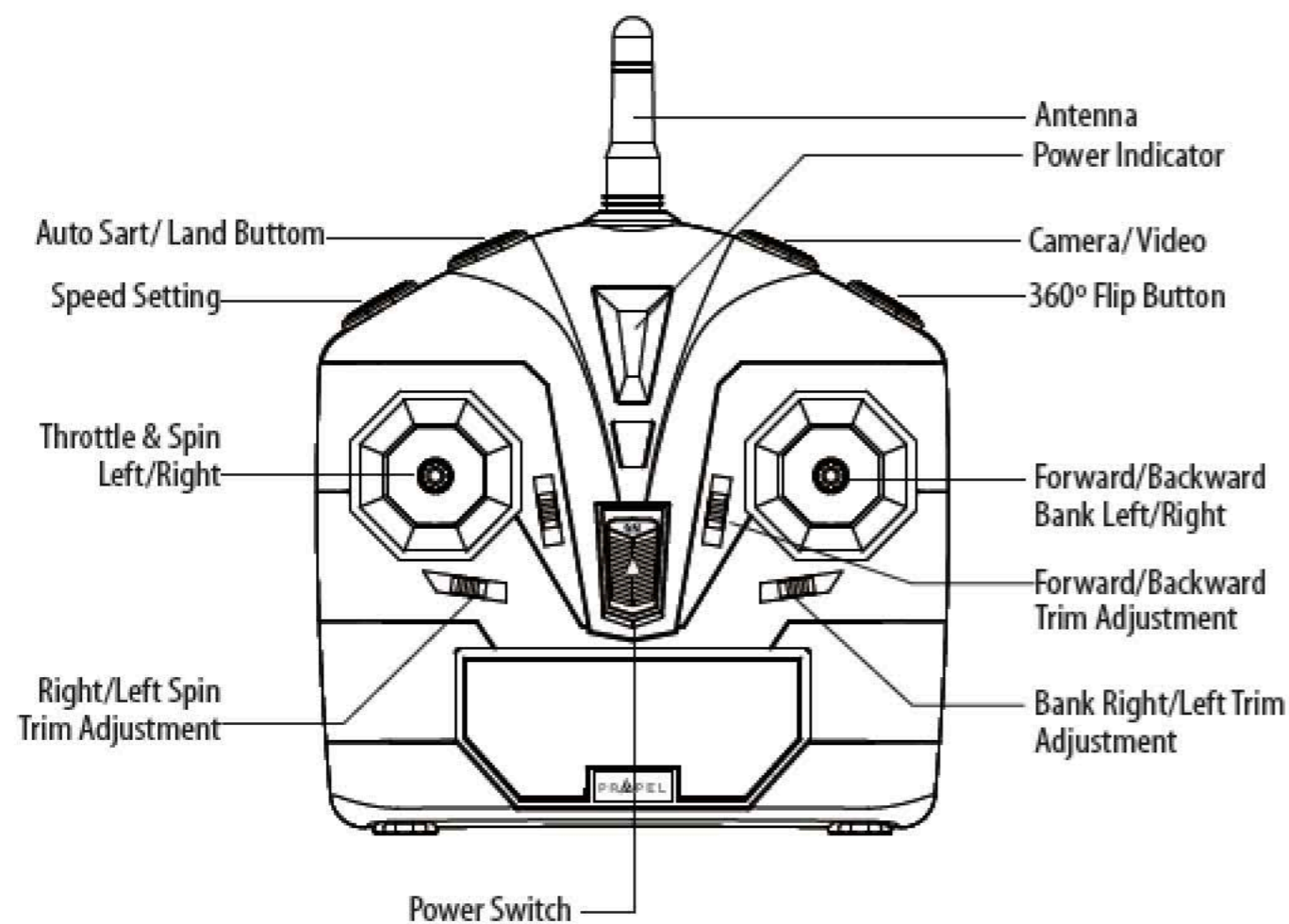

WARNING

DO NOT FLY YOUR ORBIT™ HD IN FOUL WEATHER!

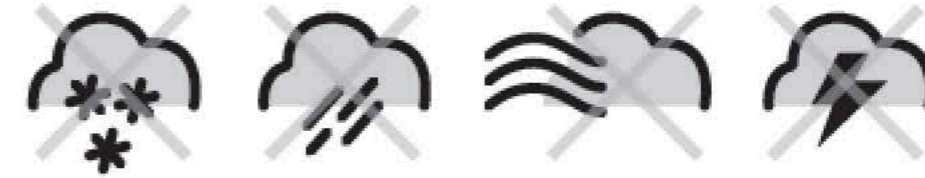

FLIGHT PREPARATION

- Verify that there are 6 "AA" batteries inside the remote control unit and the ORBIT™ HD has been fully charged.
- Make sure your ORBIT™ HD and controller are both turned on.
- Make sure to be in a large space with an open radius of at least 200 feet.
- Make sure the empty space has no obstacles. Set your ORBIT™ HD on a clean flat surface before take-off.

DO NOT ATTEMPT TO FLY YOUR ORBIT™ HD IF THERE IS RAIN, SNOW, HEAVY WINDS, THUNDER OR LIGHTNING OUTDOORS. IT COULD DAMAGE YOUR PRODUCT AND POSSIBLY EVEN CAUSE BODILY HARM.

SYNCING YOUR ORBIT™ HD

Important! When syncing your ORBIT™ HD quadcopter with the controller always make sure that the quadcopter is on a flat level surface and that your digital trim settings are in the center position. This insures that the 6 Axis gyro is properly programmed to mimic your trim settings.

Your ORBIT™ HD utilizes an automatic 2.4G channel selection system that allows up to 8 people to fly side by side in the same wireless range with no interference.

Syncing your aircraft:

1. Before starting, make sure that the power on your controller is in the OFF position and the ORBIT™ HD battery is not connected. Make sure that there are no other 2.4Ghz devices in the area as well .
2. Insert the battery into the compartment in the right direction and set it down on a flat surface. The LED indicator lights of the ORBIT™ HD should begin to flash (see diagram D).
3. Next turn ON the remote controller. After hearing a series of beeps, the ORBIT™ HD's™ flashing LED lights will start flashing at a slower rate. Pull the throttle (left control stick) all the way up and then all the way down. The LED lights will flash rapidly for a few seconds and then stay solid. You are now ready to fly the ORBIT™ HD. If this does not happen, repeat all steps above.

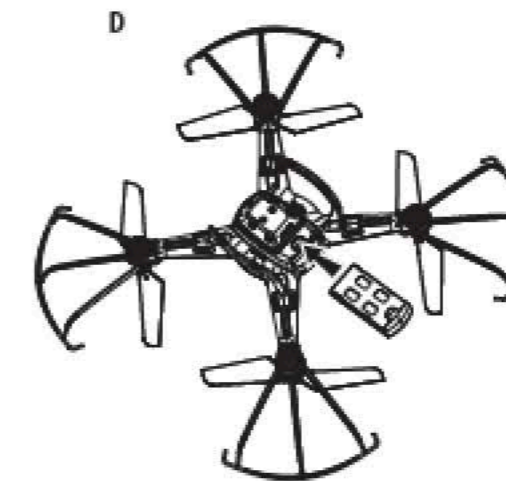

FLYING TIPS

- It is recommended that you operate the ORBIT™ HD outdoors in a wide space. The ideal space should have a 200 foot radius.
- Parental guidance or adult supervision is suggested at all times.
- If you are flying the ORBIT™ HD with others, make sure all spectators are behind you.
- For best performance, it is recommended that you operate the ORBIT™ HD in zero wind conditions. Wind can greatly affect the performance of the aircraft or cause injury.

HOW TO START/STOP ROTORS

Make sure you have properly synced the ORBIT™ HD and the power stay on.

- To start the rotors simply move the two control sticks both down and all the way in the corners, hold until the rotors starts spinning. Now release both sticks to the neutral position and push the throttle up to take off.
- To stop the rotors right after start them, you can simply wait for about 10 seconds. They will stop automatically or move both sticks down and all the way in the corners again to stop immediately. To stop the rotors after take off in the air, you can simply pull the throttle all the way down to land and it will stop on the floor.

AUTO START/LAND BUTTON

The ORBIT™ HD has an auto start/land feature which allows you to start/land automatically. Simply short press the **AUTO START /LAND** button on the top right of the controller and your ORBIT™ HD will begin taking off/Landing. (see diagram below)

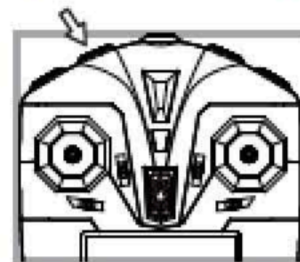

NOTE: You can still control the direction while auto starting/landing to avoid obstacles.

RECOGNIZING THE FRONT & BACK OF THE ORBIT™ HD

Even though the ORBIT™ HD has four rotors there is still a front or "forward" facing direction and "back" or backwards facing direction. The front of the Quadcopter displays WHITE LED lights and the back of the Quadcopter displays RED LED lights when activated (see diagram E).

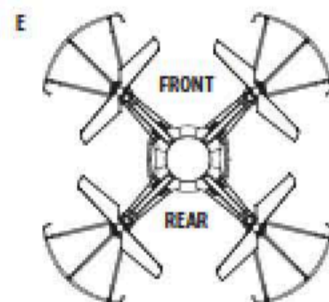

4 CHANNEL FLIGHT CONTROL

Below is a list of basic flight functions for your long-range remote control ORBIT™ HD. While learning to fly your ORBIT™ HD it is best to start with a large space until you get used to the basic controls. As you master flying your ORBIT™ HD you can move to more advanced maneuvering techniques. Practice makes perfect! When you have these basic steps down you can move to the next level.

Move the left Throttle stick up to increase the speed and the ORBIT™ HD will accelerate and ascend.

Move the left Throttle stick down to decrease the speed and the ORBIT™ HD will decelerate and descend (see diagram F).

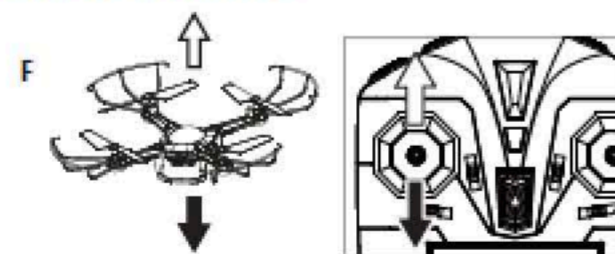

Move the left Throttle stick left and the ORBIT™ HD will rotate left.

Move the left Throttle stick right and the ORBIT™ HD will rotate right (see diagram G).

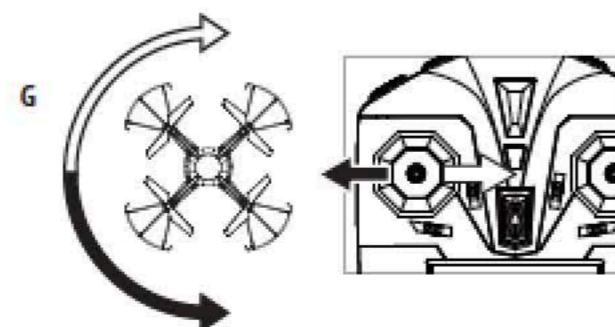

Move the right Direction Stick up while in flight and the ORBIT™ HD will move forward.

Move the right Direction Control down while in flight and the ORBIT™ HD will move backward (see diagram H).

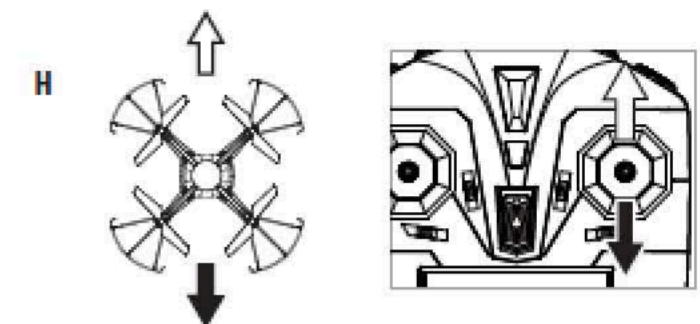

Move the right Direction Control left and the ORBIT™ HD will bank to the left.

Move the right Direction Control right and the ORBIT™ HD will bank to the right (see diagram I).

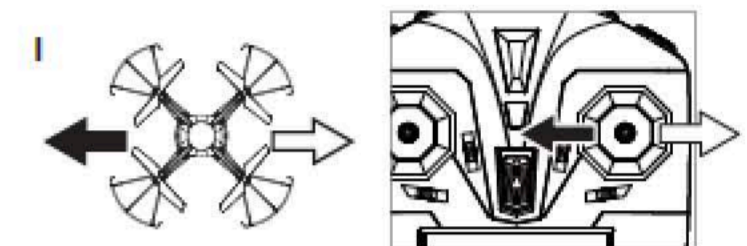

ADJUSTING TRIM

From time to time you may have to adjust the TRIM buttons to ensure the ORBIT™ HD will hover in mid-air and respond accurately to your commands (make all trim adjustments while the drone is in air).

Forward/Backward Trim

- If your ORBIT™ HD drifts forward, push and release the BACKWARD TRIM button back repeatedly until the motion stops and proper flight is maintained (see diagram J).
- If your ORBIT™ HD drifts backwards, push and release the FORWARD TRIM button forward in the same manner until the problem is resolved.

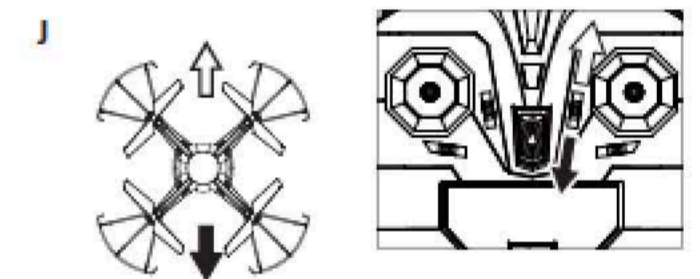

Right/Left Trim

- If your ORBIT™ HD drifts left, push and release the RIGHT TRIM button back repeatedly until the motion stops and proper flight is maintained (see diagram K).
- If your ORBIT™ HD drifts right, push and release the LEFT TRIM button in the same manner until the problem is resolved.

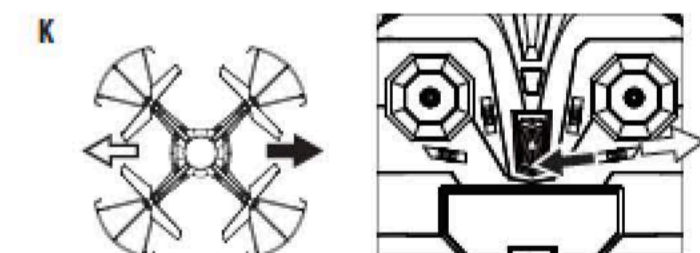

Right/Left Spin Trim

- If your ORBIT™ HD spins left, push and release the RIGHT SPIN TRIM button back repeatedly until the motion stops and proper flight is maintained (see diagram L).

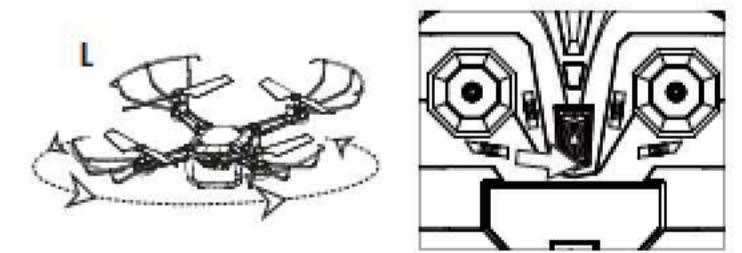

- If your ORBIT™ HD spins right, push and release the LEFT SPIN TRIM button in the same manner until the problem is resolved (see diagram M).

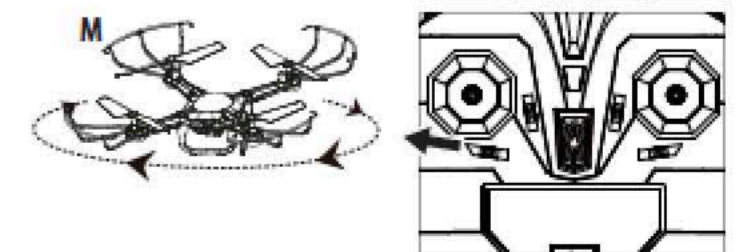

LEVEL SURFACE CALIBRATION

If the aircraft becomes unstable during the course of flying, you may need to restabilize the internal gyros.

To do this, Turn Off the controller and disconnect the Drone battery. Place the ORBIT™ HD on a flat level surface. Follow the steps to sync your ORBIT™ HD (page 4). Now, pull both the joysticks downwards and towards the right at the same time (see diagram N). The lights on the drone will flash a bit and then remain solid. This indicates that your drone has been calibrated.

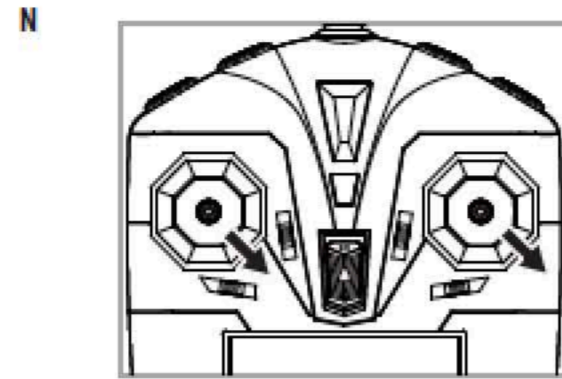

FLYING ENVIRONMENT

The ORBIT™ HD is designed for outdoor use only. When flying, do so in warm sunny weather with no wind or rain.

WARNING: Do not fly in extreme temperatures or windy conditions as this may affect the performance of your ORBIT™ HD and cause damage or injury.

FLIGHT PRACTICE

To master flying your aircraft try practicing the exercises shown below. Start with simple vertical takeoffs, landings, and left/right turning and rotating. Once those are mastered move on to square and cross maneuvers. Good luck and have fun!

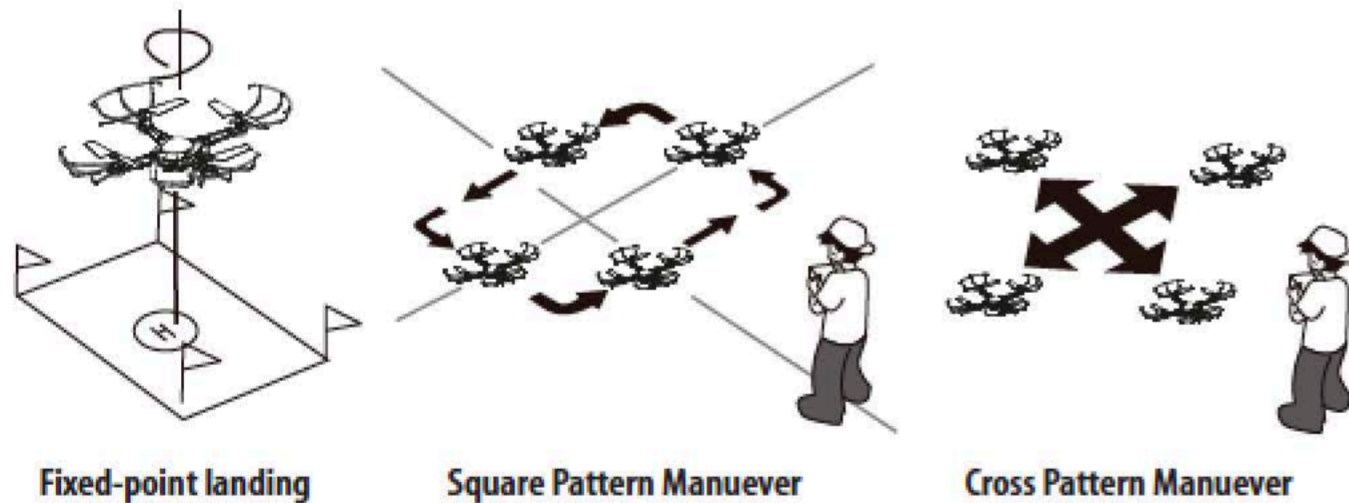

PERFORMING 360° FLIPS

After you have mastered flying the ORBIT™ HD you are ready to try flips. Once the ORBIT™ HD is hovering at least 3 meters (about 10 feet) off the ground, trigger the 360° Flip Button (see diagram O) and push the right lever forward slightly and let go. The ORBIT™ HD will instantly perform a forward flip. To perform a backwards or side flip press and hold the 360° Flip Button and push the right lever in the direction you wish to flip just as you did for the forward flip (see diagram P & Q).

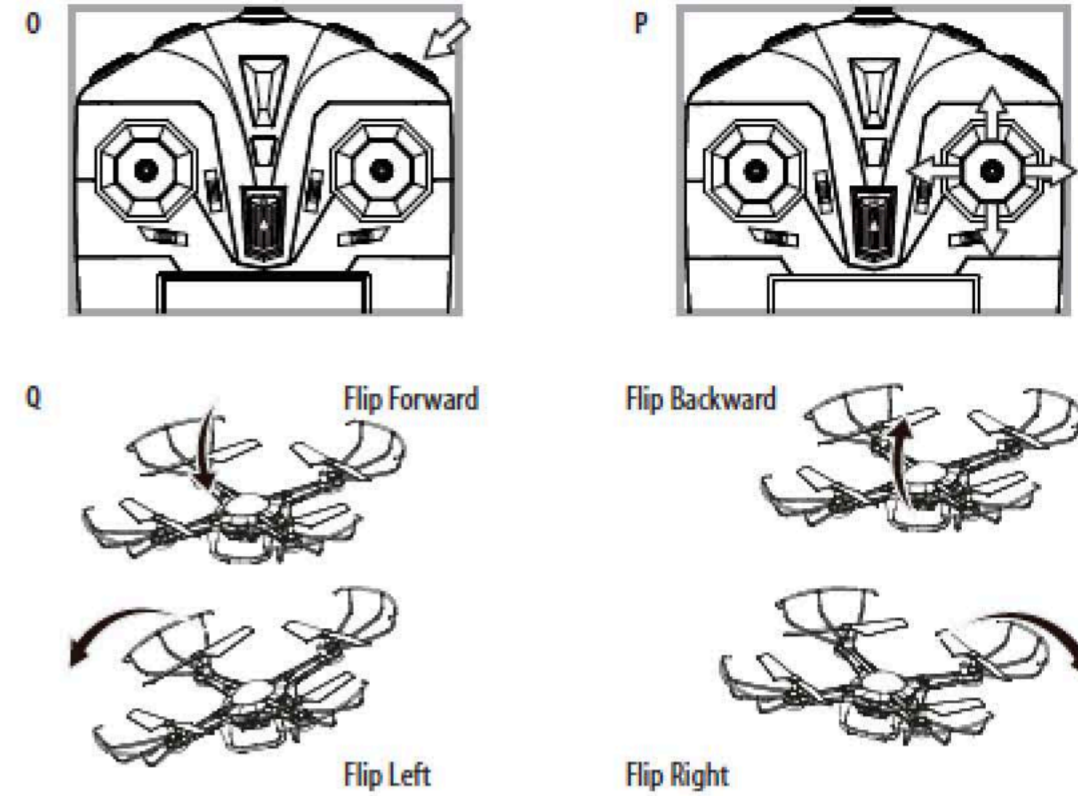

TROUBLESHOOTING YOUR ORBIT™ HD

PROBLEM	POSSIBLE REASON	SOLUTION
No Power	<ol style="list-style-type: none"> 1. Power switched off 2. Polarity is reversed 3. Batteries may be dead 	<ol style="list-style-type: none"> 1. Switch the ON/OFF switch to ON 2. Make sure all batteries are installed correctly (see diagram B) 3. Replace batteries
Remote Not properly Responding	<ol style="list-style-type: none"> 1. Remote is switched off 2. ORBIT™ HD battery is not connected 3. Too windy 4. The remote is not synced 	<ol style="list-style-type: none"> 1. Switch the ON/OFF switch to ON 2. Connect the battery to ORBIT™ HD 3. Windy conditions severely impair the operation of the ORBIT™ HD 4. Re-sync the remote
Aircraft Won't lift off	<ol style="list-style-type: none"> 1. Rotor speed too slow 2. Aircraft not fully charged 	<ol style="list-style-type: none"> 1. Push throttle lever forward 2. Recharge your ORBIT™ HD
Aircraft Descends Too Fast	<ol style="list-style-type: none"> 1. Moving the throttle too quickly 	<ol style="list-style-type: none"> 1. Control the throttle slower and smoother
Aircraft Not Responding	<ol style="list-style-type: none"> 1. Gyroscopes not functioning 	<ol style="list-style-type: none"> 1. Turn ON the ORBIT™ HD and Reset the Gyros (see diagram P)
Loss of ORBIT™ HD Control	<ol style="list-style-type: none"> 1. Aircraft is out of range of remote 	<ol style="list-style-type: none"> 1. Keep the aircraft within a 300 feet radius of the remote

OPERATING THE CAMERA

You can take in-flight photos or video with your ORBIT™ HD on board camera.

1. Ensure that the camera module is securely attached and locked onto the copter. Insert the microSDHC card carefully into the slot on the rear of the camera module. Push in gently until you hear and feel a click. Now you are ready to use the camera.
2. To take still pictures, short press the camera button. The indicating LED light will flash 3 times.
3. To take video footage, hold down the camera button on the remote for a few seconds (see diagram T1). To stop video footage simply press the button again.
4. After turning the Power Off on the copter, you may now remove the microSDHC card from the ORBIT™ HD by gently pushing on the back of the card with your thumb until you hear and feel a slight click. You may use the included USB card reader to connect it to a computer and retrieve your pictures and video footage.

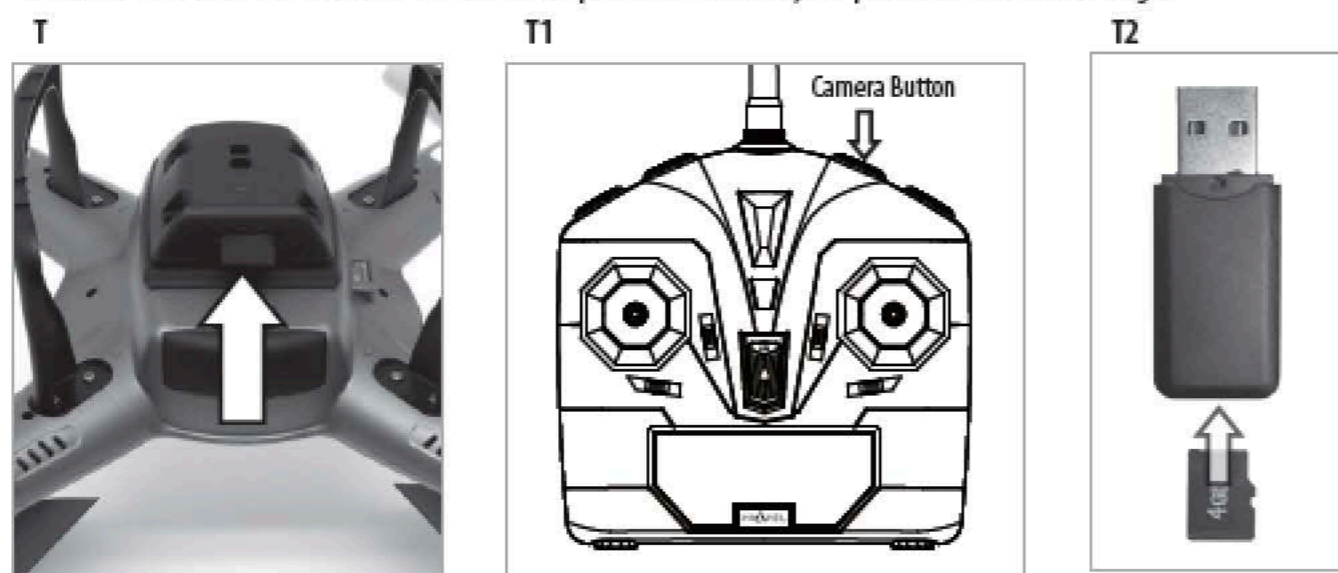

REPLACING THE PROPELLER BLADES

NOTE : Always disconnect the battery before replacing the propeller blades.

Your ORBIT™ HD propeller system is a precision instrument that may need repair or replacement from time to time for optimal flight function. Crash landing from high-speed aerial flights may cause damage to your ORBIT™ HD propellers.

The ORBIT™ HD has four propeller blades, two on the front and two on the back. Each one of these propellers is marked with either A or B on the underside.

1. When replacing the propeller blades, carefully unscrew the broken propeller from the rotor shaft.
2. Replace the damaged blade with the correct new blade. Ensure that the identification letter on the broken blade and on the new blade are the same before screwing back on (See diagram U).

NOTE : The Color of the blade does not matter. What matters is the identification letter on the bottom of blade. All "A" blades would perform the same ir-respective of color and the same would apply for "B".

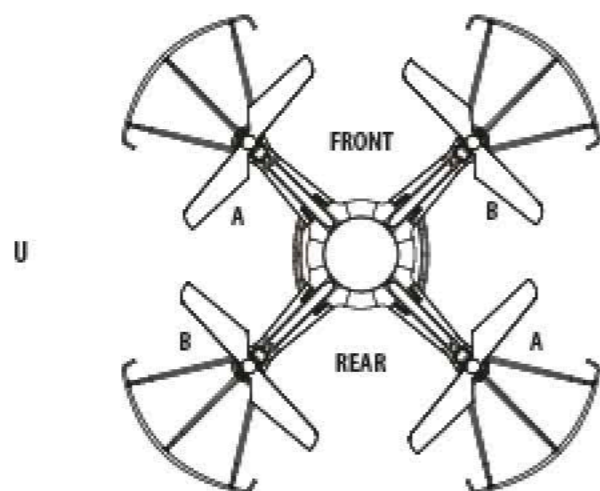

ORBIT™ HD WARNING:

The ORBIT™ HD is designed for OUTDOOR use only. The ORBIT™ HD blades revolve at high speeds and can cause damage to the user, spectators and animals. Stand away from the ORBIT™ HD to reduce the risk of getting into the flight path. Warn spectators that you will be flying your ORBIT™ HD so that they are aware of its position. Before flight, inspect the rotor blades to make certain that the blades are securely fastened to the ORBIT™ HD.

WARNING!

- Choking/Cutting Hazard. Small Parts/Sharp Rotor Blades.
- Keep hands, hair and loose clothing away from the propeller when the power switch is turned to the ON position.
- Turn off the transmitter and take out the battery from the ORBIT™ HD when not in use.
- The included charger is built specifically for the ORBIT™ HD Li-Poly battery. Do not use it to charge any other battery.
- New alkaline batteries are recommended for maximum performance.
- Parental supervision recommended when flying ORBIT™ HD.

BATTERY WARNINGS

RECHARGEABLE BATTERY:

This ORBIT™ HD uses a Li-Poly rechargeable battery. If battery can no longer be charged, dispose it battery properly according to the local law.

CONTROLLER BATTERIES:

Remote control requires 6 "AA" batteries (not included). Please read the important battery safety warning below.

- Do not mix alkaline, standard (carbon-zinc) and rechargeable batteries (Nickel Metal Hydride).
- Do not mix old and new batteries.
- Non-rechargeable batteries are not to be recharged.
- Rechargeable batteries are to be removed from the item before being charged (if removable).
- Rechargeable batteries are only to be charged under adult supervision.
- Exhausted batteries should be removed immediately and must be recycled or disposed of properly according to state or local government ordinances and regulations.
- The supply terminals are not to be short-circuited.
- Only batteries of the same or equivalent type as recommended are to be used.
- Batteries are to be inserted with the correct polarity (see inside booklet for diagram).
- Do not dispose batteries in a fire - batteries may leak or explode.

CARE AND MAINTENANCE

- Always remove the batteries from the wireless remote control when it is not being used for an extended period of time.
- To clean, gently wipe the remote control and ORBIT™ HD with a clean damp cloth.
- Keep the toy away from direct heat or sunlight.
- Do not submerge the toy into water. This can damage the unit beyond repair.
- Parental guidance recommended when installing or replacing the batteries.