

FCC Part 15 C Notice

CAUTION: Changes or modifications not expressly approved by the party responsible for compliance could void the user's authority to operate the equipment.

NOTE: This equipment has been tested and found to comply with the limits for a Class B digital device, pursuant to Part 15 of the FCC Rules. These limits are designed to provide reasonable protection against harmful interference in a residential installation. This equipment generates, uses and can radiate radio frequency energy and, if not installed and used in accordance with the instructions, may cause harmful interference to radio communications. However, there is no guarantee that interference will not occur in a particular installation. If this equipment does cause harmful interference to radio or television reception, which can be determined by turning the equipment off and on, the user is encouraged to try to correct the interference by one or more of the following measures:

- Reorient or relocate the receiving antenna.
- Increase the separation between the equipment and receiver.
- Connect the equipment into an outlet on a circuit different from that to which the receiver is connected.
- Consult the dealer or experienced radio/TV technician for help.

This device complies with Part 15 of the FCC Rules. Operation is subject to the following two conditions :

- (1) This device may not cause harmful interference, and
- (2) this device must accept any interference received, including interference that may cause undesired operation.

INDUSTRY CANADA NOTICE: CANADA ONLY.

This device complies with Industry Canada licence-exempt RSS standard(s). Operation is subject to the following two conditions: (1) this device may not cause interference, and (2) this device must accept any interference, including interference that may cause undesired operation of the device.

Le présent appareil est conforme aux CNR d'Industrie Canada applicables aux appareils radio exempts de licence. L'exploitation est autorisée aux deux conditions suivantes : (1) l'appareil ne doit pas produire de brouillage, et (2) l'utilisateur de l'appareil doit accepter tout brouillage radioélectrique subi, même si le brouillage est susceptible d'en compromettre le fonctionnement.

CAN ICES-3 (B)/NMB-3(B)

This product meets the applicable Innovation, Science and Economic Development Canada technical specifications.

Ce produit répond aux spécifications techniques pertinentes d'Innovation, Science et Développement économique applicables.

Important! Register Your Drone

The U.S. Department of Transportation's Federal Aviation Administration (FAA) announced a streamlined and user-friendly web-based aircraft registration process for owners of small unmanned aircraft (UAS) weighing more than 0.55 pounds (250 grams) and less than 55 pounds (approx. 25 kilograms) including payloads such as on-board cameras.

Owners can get more info and may register through a web-based system at www.faa.gov/uas/registration



Requires Speed Class 6 or higher microSD or microSDHC card (not included)
microSDHC Logo is a trademark of SD-3C, LLC.

Conforms to safety requirements of RSS210 and FCC.

©2017 Rooftop Brands™ All rights reserved

Tel: + (1) 949-566-9573 • www.propelrc.com

Made in China
V1.0

X5+ WiFi

Outdoor Drone with HD Camera and Streaming Video



INSTRUCTION BOOKLET

WARNING: Never leave product charging unattended for extended periods of time. Always disconnect the battery from charger immediately after the battery is fully charged. Please refer to enclosed safety instructions.

PACKAGE CONTAINS:

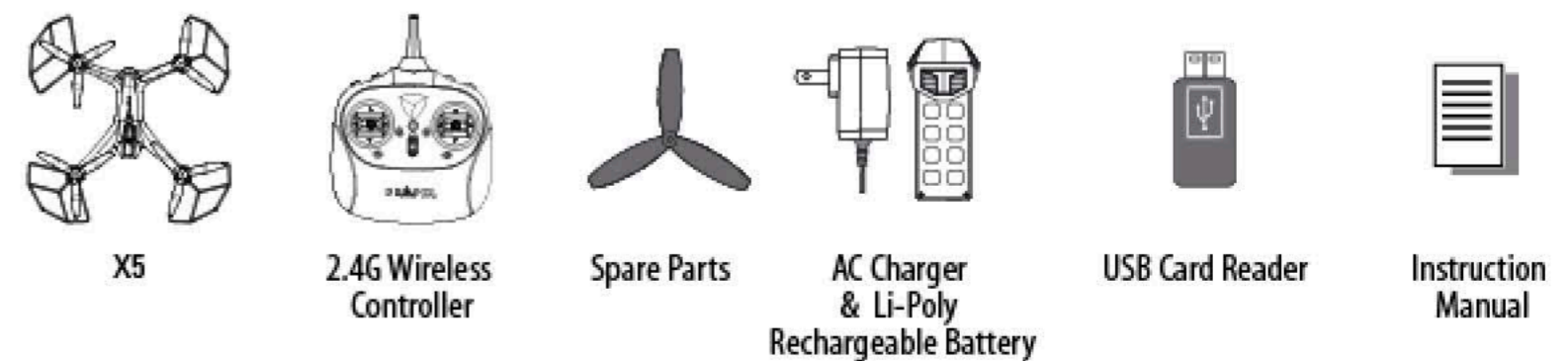

Colors and styles may vary slightly.

PROPEL

ARTWORK NO.	DESCRIPTION	MDSER	DESIGNER	DATE
Co6-BBB OC+WiFi IM	114x174mm	Tina	Cocoa	2017/7/03

TABLE OF CONTENTS

Product Features.....	2
Remote Control Battery Installation.....	2
Charging the X5's Li-Poly Battery.....	2
X5 Battery Installation.....	2
X5 Diagram.....	3
Control Diagram.....	3
Flight Preparation.....	4
Syncing Your X5.....	4
Now You Are Ready To Fly.....	5
Recognizing The Front & Rear Of The X5.....	5
Starting/Stopping The Rotors.....	5
Manual Start/Stop.....	5
Auto Start/Land.....	5
Understanding The Altitude Lock Sensor.....	5
Optical Flow.....	6
Speed Select Button.....	6
3 Channel VS 4 Channel Flying.....	6
3 Channel Flight Control.....	6
4 Channel Flight Control.....	7
Flight Practice.....	7
Adjusting The Trim.....	8
Calibrating The X5.....	9
How To Perform 360° Stunt Rolls.....	10
Using Your On-Board Camera and Video Recorder.....	11
Removing Your microSD Card.....	12
Downloading and Clearing Space on Your microSD Card.....	12
Propel X5 WiFi APP Installation.....	13
Pairing X5 to Your Compatible Device.....	13
Quick Start.....	13
Detailed APP Overview.....	14
Troubleshooting Your X5.....	15
Replacing The Propeller Blades.....	15
Warnings.....	16
Battery Warnings.....	16
Care and Maintenance.....	16
FAA Information.....	17
FAA Information.....	18
FCC Information.....	19

Thank you for purchasing the X5 2.4 Ghz Quadcopter. Please read this instruction booklet as it contains valuable information on how to properly fly and care for your X5.

PRODUCT FEATURES

- Optical flow sensor holds flight position and increases stability.
- Air pressure sensor locks flight altitude for stable video footage.
- High capacity battery provides for extended flight time.
- On board camera records high-definition video and captures still pictures with the push of button.
- 6 axis gyro for extremely stable flight and maneuverability.
- Push button 360° aerial stunts.
- Wide range digital radio allows flight range up to 400 feet!
- Digital controller, rechargeable battery and additional replacement parts included.

REMOTE CONTROL BATTERY INSTALLATION

1. Slide off the battery cover from the back of the controller.
2. Install 4 fresh "AA" alkaline batteries into the controller as shown in diagram A. Replace the battery cover.
3. Turn over the controller and turn the on/off switch to the on position. If the power indicator turns on you have installed your batteries properly.

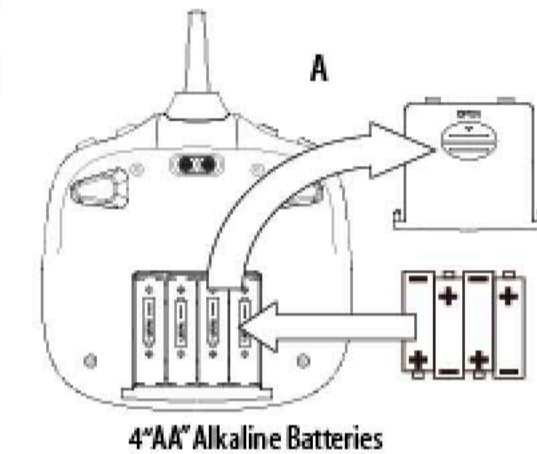

CHARGING THE X5 LI-POLY BATTERY

1. Connect the battery to the battery charger as shown (see diagram B).
2. Next, plug the AC adaptor into a standard wall socket.
CAUTION: improper connection may damage the battery.
Note: The battery has a RED LED indicator light which will light up while charging.
3. When the battery is fully charged the red charging indicator light will turn off.
4. Average charging time is approximately 80-100 minutes. A fully charged drone can fly for approximately 10 minutes depending on environment and user input.

NOTE: You may purchase additional batteries and chargers at www.propelrc.com

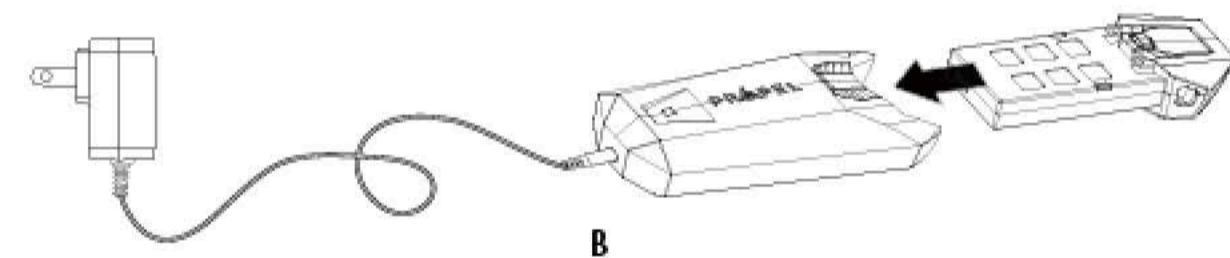

IMPORTANT: ALWAYS REMEMBER TO DISCONNECT YOUR BATTERY CHARGER WHEN NOT IN USE!

X5 BATTERY INSTALLATION

1. Insert the battery into the battery compartment all the way in, you will hear or feel a click (see diagram C). The battery is designed to only fit in the compartment one-way, do not force it in.
2. After you install the battery, short press the power button, the LED lights on the drone will start flashing rapidly for a few second then slower. Also on the top of the drone there are 4 LED lights indicating battery capacity will come up and stay on.
Note: If the battery is not full, one or more indicating LED lights will be off. If there is only one light comes on and is flashing, you will need to charge the battery right away.
3. Removing the battery: Press down the battery lock at the top side of the battery then pull it out gently from the battery compartment.

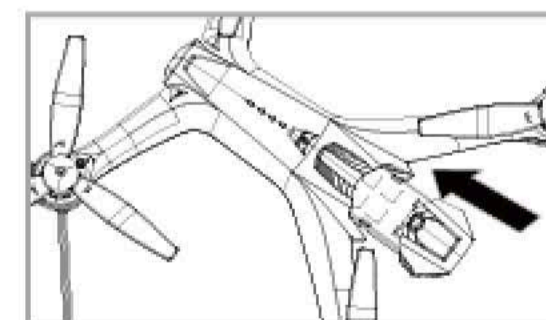

C

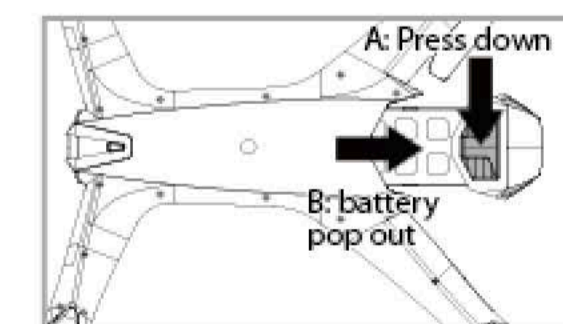

X5 DIAGRAM

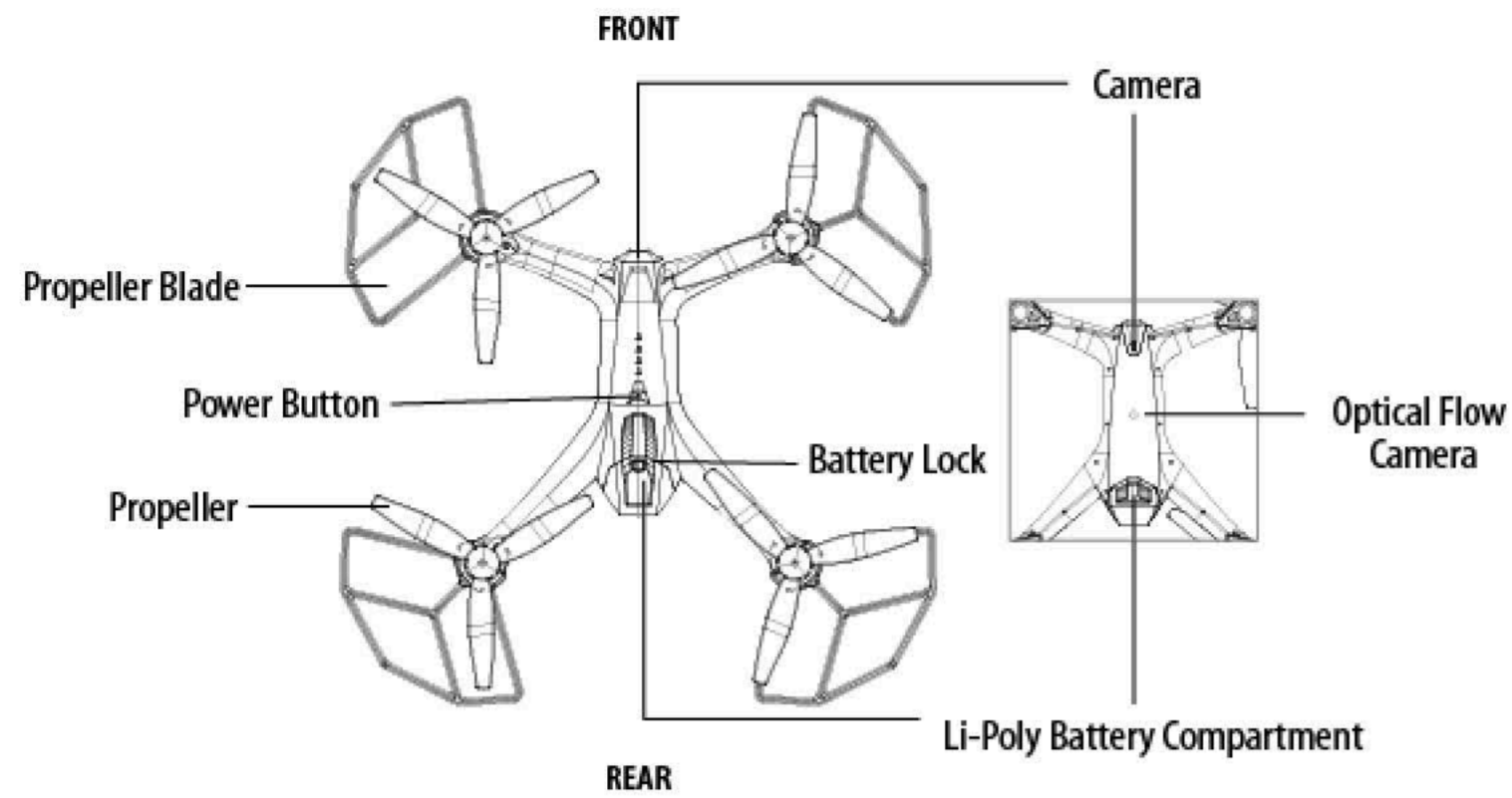

CONTROLLER DIAGRAM

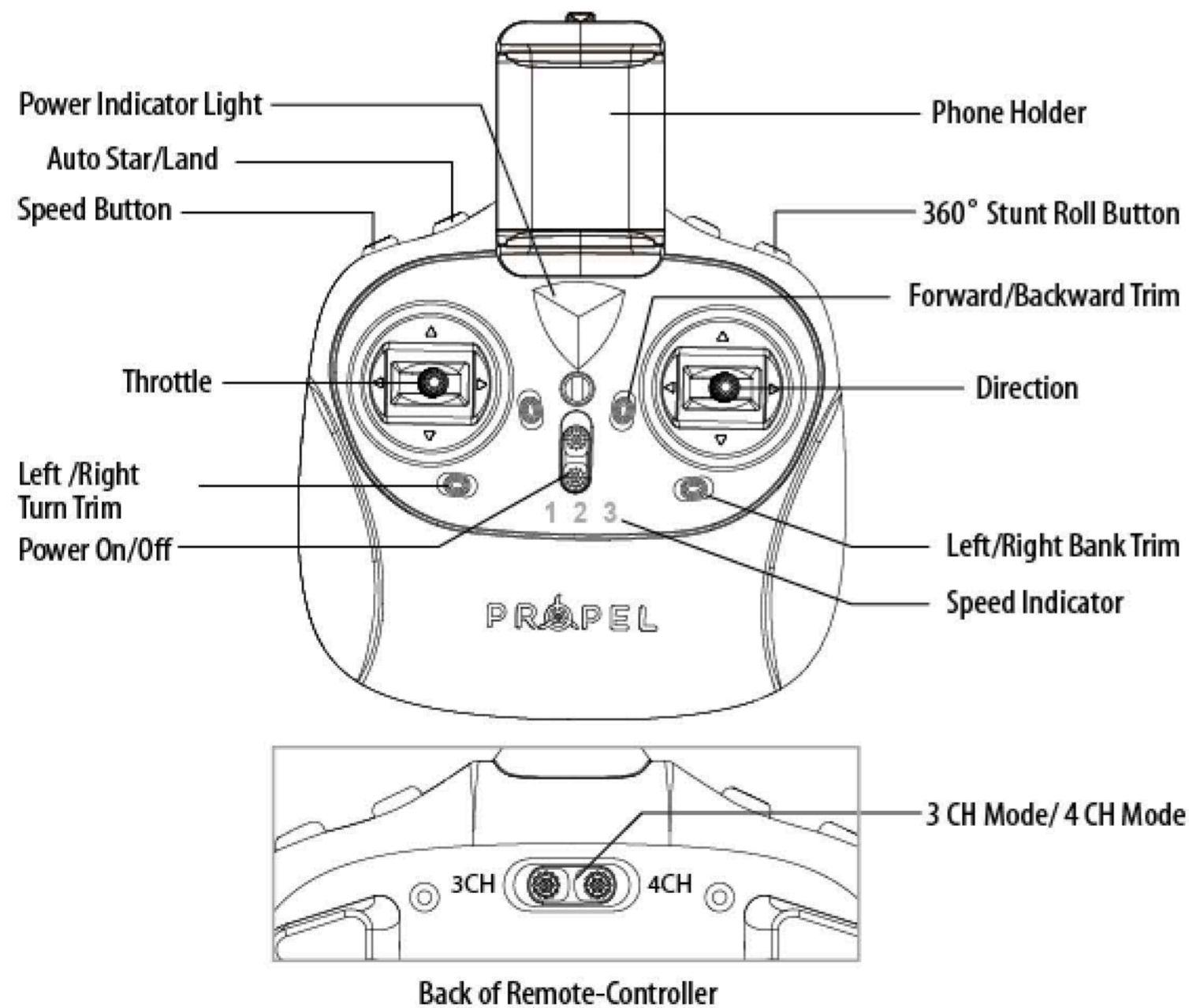

WARNING

DO NOT FLY YOUR X5 IN FOUL WEATHER!

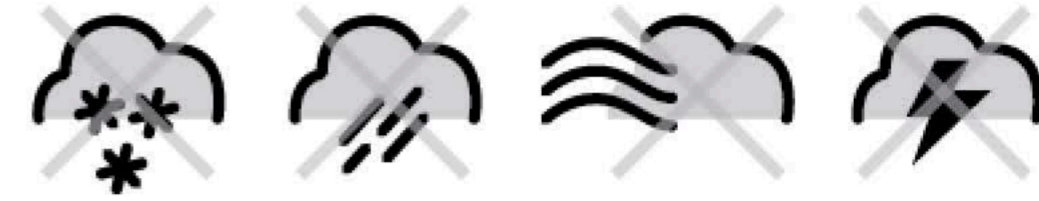

FLIGHT PREPARATION

- Verify that there are 4 "AA" batteries inside the remote control unit and the X5 has been fully charged.
- Make sure to be in a large open space preferably a field or a park with an open radius of at least 200 feet.
- Make sure to start your drone on a clean flat level surface before take-off.
- **IMPORTANT! Until you have experience in flying your X5, it is not advised to use in any rate of wind. Wait until a zero wind day or extremely light wind when learning how to fly.**

SYNCING YOUR X5

Important! When syncing your X5 with the controller always make sure that the drone is on a flat level surface and that your digital trim settings are in the center position. This insures that the 6 axis gyro is properly programmed to respond to your trim settings. Your X5 utilizes an automatic 2.4G channel selection system that allows up to 8 people to fly side by side in the same wireless range with no interference.

1. Before starting, make sure that the power switch on your controller is off and the battery is removed from the X5. Make sure that there are no other 2.4G devices in the area.
2. Insert the battery into the X5 and set it down on any flat level surface short press the power button, the red and white LED lights on top of the drone should begin running. And the red lights on the back of the drone will come up and stay on.
3. Quickly turn ON the remote and you will notice that the top red LED light on the face of the controller should also be flashing.
4. Push the throttle stick all the way up until it stops and then pull it back all the way down to the bottom (see illustration below). When pushing the stick up or pulling the stick down you should hear a high-pitched beep both ways and the indicating light will stop flash and stay solid on. You have successfully synced your X5 and are ready to fly. If this doesn't happen repeat steps 1-4 again.

- **TIP 1: Try not to leave too much time between putting your battery into the drone and turning on the controller or your syncing window will time-out.**
- **TIP 2: Syncing your drone indoors or in the shade will make it easier to see the LED light indicators on both the controller and the drone.**

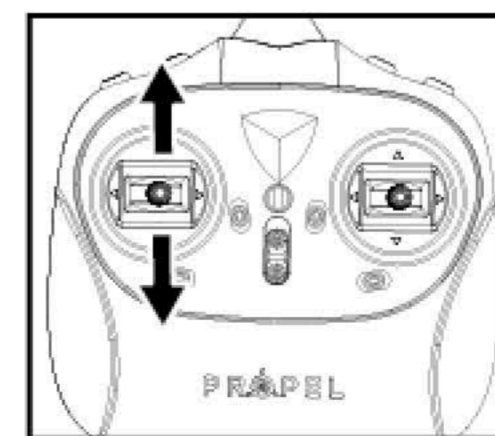

Move the control stick all the way up and all the way down, you should hear a beep both ways

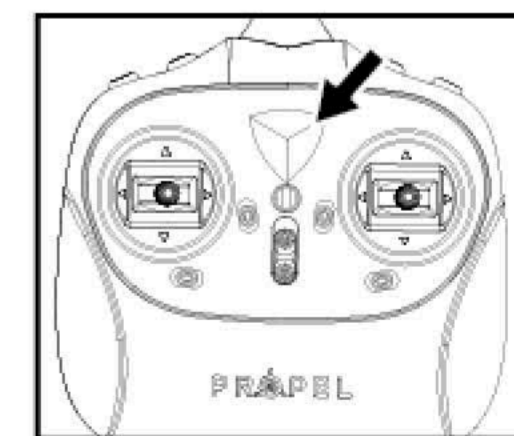

The flashing red LED light will become solid when you are synced

NOW YOU ARE READY TO FLY!

If you have successfully synced your X5 to your controller as explained on page 4 you are now ready to fly. Before beginning to fly your drone you should familiarize yourself with how to start and stop the rotors, how to use your auto land feature and how the controls work so please carefully read and familiarize yourself with various control features explained in the next few pages. Once again as a beginner pilot you should learn how to control your drone in a large open field or park on a day with zero or very light wind. Do not try to fly your X5 too high until you become a more experience pilot.

RECOGNIZING THE FRONT & REAR OF THE X5

Even though the X5 has four rotors there is still a front or "forward" facing direction and "rear" or backwards facing direction. The front and forward facing direction of the X5 is the side with two EYES (see diagram E). The rear and backward facing direction of the Quadcopter is the side with battery compartment (see diagram E).

NOTE: The front of the Quadcopter also displays running WHITE LED light and the back of the Quadcopter displays running RED LED lights.

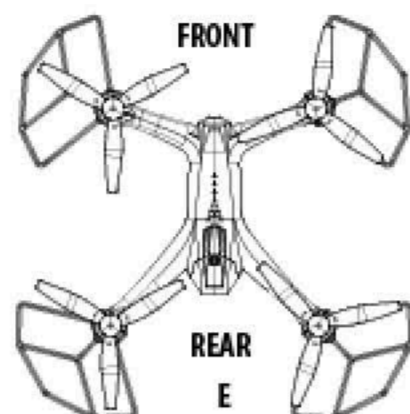

STARTING/STOPPING THE ROTORS

Note: You can start/stop your X5 manually or automatically.

Please follow one of the steps below to operate accordingly. Make sure you have properly synced the X5 and the power stays on.

MANUAL START/STOP

- To start the rotors simply move the two control sticks both down and out (see diagram), hold until the rotors start spinning. Now release both sticks to the neutral position and push the throttle up to take off.
- To stop the rotors, after starting them you can simply wait about 10 seconds, and they will stop automatically. Or move both sticks down and out again to stop immediately. After take off, you can simply pull the throttle all the way down and land.

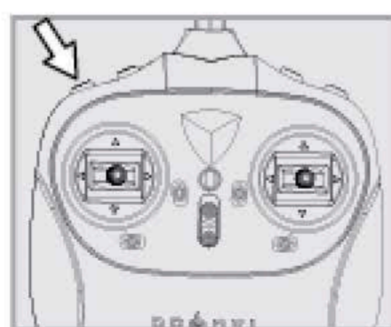
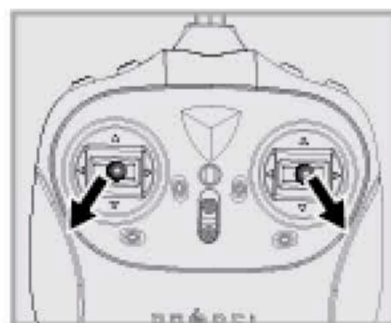

AUTO START/LAND

The X5 has an auto start/land feature which allows you to start/land automatically. Simply press the **AUTO START/LAND** button on the top of the controller and your X5 will begin taking off/landing (see diagram below).

NOTE: You can still control the direction while auto starting/landing to avoid obstacles.

UNDERSTANDING THE ALTITUDE LOCK SENSOR

The X5 has a unique Altitude Lock function, air pressure sensor that allows for easier flight control and stability. A beginner's friend, it allows the user to ease into piloting the copter. The sensor locks in the altitude of the copter while allowing the user to adjust the directional controls without having to hold the throttle.

After starting the copter, fly it upwards to a safe height. Once at a safe height, release the throttle to the neutral position. Now your X5 should be locked in the altitude and you can focus on getting used to the directional controls of the X5. The copter always tends to self correct and go back to the last locked height after moved up or down by outside forces.

Note: The altitude sensor does have some tolerance based on atmospheric conditions and could have a slight variation in altitude.

OPTICAL FLOW

The X5 Optical Flow technology utilizes a separate downward facing camera which analyzes the image of the ground below in realtime. Then using this image and its unique control system algorithms it works to keep the drone in one stationary position regardless of wind or any other factors that might cause the drone to drift. The Optical flow feature is only functional at altitudes below 30ft in the air.

SPEED SELECT BUTTON

The X5 has 3 speed settings; 1 (SLOW), 2 (MEDIUM) and 3 (HIGH). The Default setting when you first turn on your X5 is the 1 (SLOW) speed mode. To increase the speed simply trigger the speed setting button (see remote diagram on pg 3) you will hear a beep and the speed setting indicator on the face of the controller will show you what speed setting you are on. Speed settings can be set before flight or during the flight.

3 CHANNEL VS 4 CHANNEL FLYING

Propels unique "switch-blade" technology allows you to choose between 3ch or 4ch flight control modes. Most people with no experience in flying multi copters may find 3ch easier to learn at first as controls are set up to simply move forward, back, turn left and turn right. 4channel flying gives the operator ultimate control by adding two more dimensions of flight, banking left and banking right.

To change to 3 Channel mode:

Switch the 3/4 CH button to left side on the back of controller (see remote diagram on pg 3), you will hear 3 "beeps" indicating the X5 now is set to 3 CH mode.

To change to 4 Channel mode:

Switch the 3/4 CH button to right side on the back of controller (see remote diagram on pg 3), you will hear 4 "beeps" indicating the X5 now is set to 4 CH mode.

3 CHANNEL FLIGHT CONTROL

Below is a list of basic flight functions for your long-range remote to control the X5. While learning to fly your X5 it is best to start in a large space with the drone facing away from you until you get used to the basic controls. As you master flying your X5 you can move to more advanced maneuvering techniques. Practice makes perfect! When you have these basic steps down you can move to the next level.

Move the Throttle stick up to increase the propeller speed and the X5 will accelerate and ascend.
Move the Throttle stick down to decrease the propeller speed and the X5 will decelerate and descend (see diagram F).

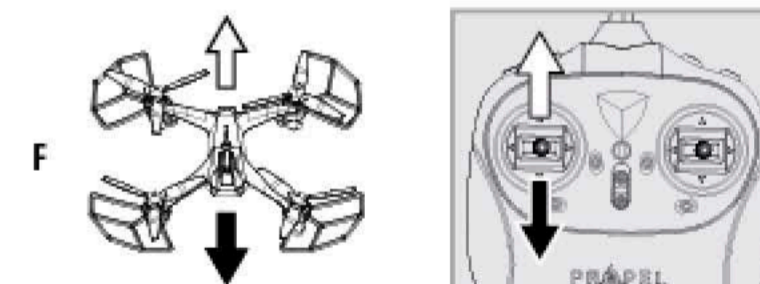

While in the air, move the Direction Stick up and the X5 will move forward.
Move the Direction Control down and the X5 will move backward (see diagram G).

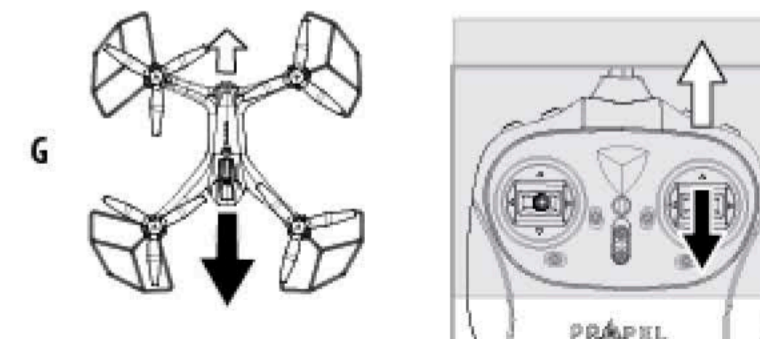

While in the air, move the Direction Control left and the X5 will spin to the left.
Move the Direction Control right and the X5 will spin to the right (see diagram H).

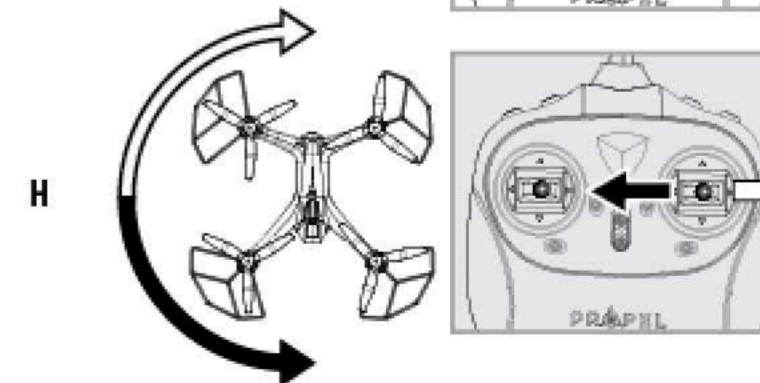

4 CHANNEL FLIGHT CONTROL

Below is a list of basic flight functions for your long-range remote to control the X5. While learning to fly your X5 it is best to start in a large space with the drone facing away from you until you get used to the basic controls. As you master flying your X5 you can move to more advanced maneuvering techniques. Practice makes perfect!

Move the Throttle stick up to increase the propeller speed and the X5 will accelerate and ascend.

Move the Throttle stick down to decrease the propeller speed and the X5 will decelerate and descend (see diagram I).

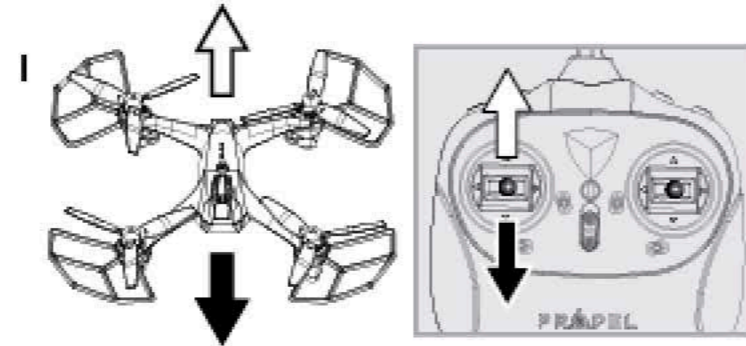

While in the air, move the left Throttle stick left and the X5 will rotate left.

Move the Throttle stick right and the X5 will rotate right (see diagram J).

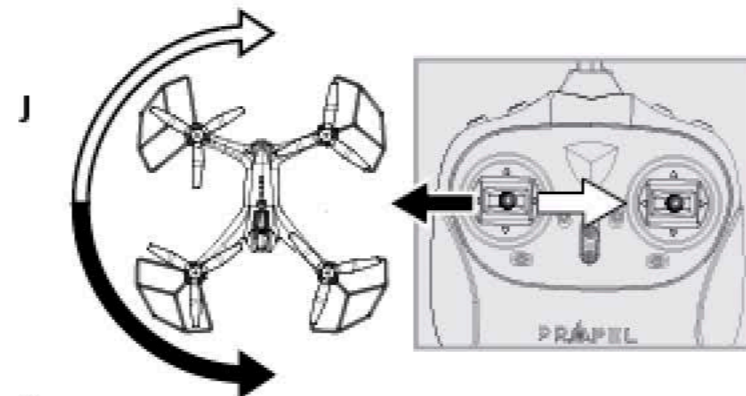

While in the air, move the Direction Stick up and the X5 will move forward.

Move the Direction Control down and the X5 will move backward (see diagram K).

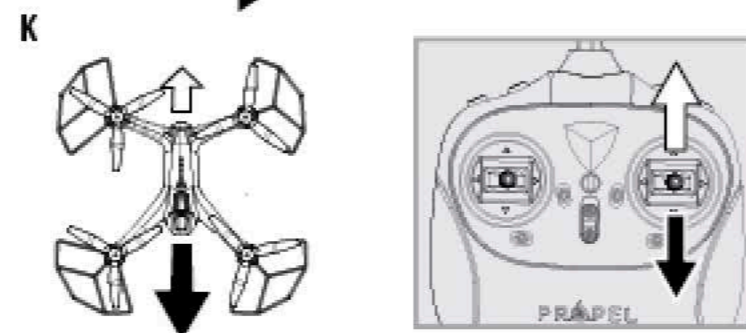

While in the air, move the Direction Control left and the X5 will bank to the left.

Move the Direction Control right and the X5 will bank to the right (see diagram L).

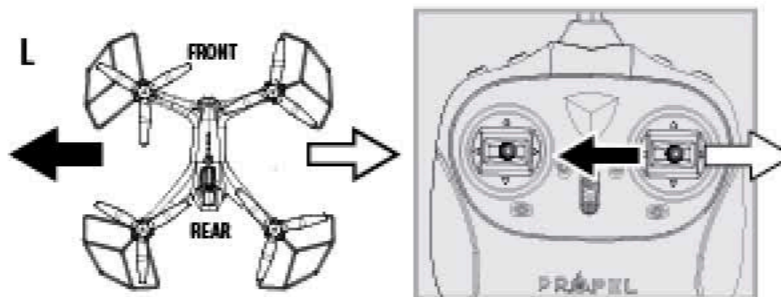

FLIGHT PRACTICE

To master flying your aircraft try practicing the excursions shown below. Start with simple vertical takeoffs, landings, and left/right turning and rotating. Once those are mastered move on to square and cross maneuvers. Good luck and have fun!

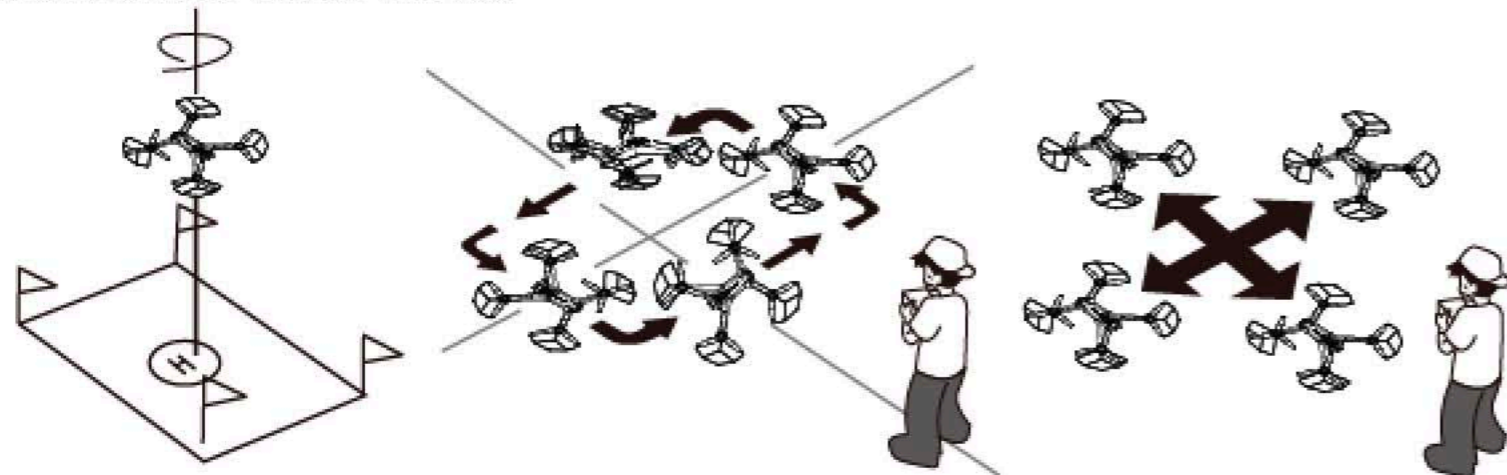

Fixed-Point Landing

Square Pattern Maneuver

Cross Pattern Maneuver

ADJUSTING THE TRIM

NOTE: The X5 is already properly trimmed and calibrated right out of the box and should not require any trim adjustments before flying. Some more experienced pilots may want to adjust trim settings for their style of flying. After several crashes you may need to adjust trim settings for the X5's destabilization.

Forward/Backward Trim

- If your X5 drifts forward while in the air, push and release the FORWARD/BACKWARD TRIM button backward repeatedly until the motion stops and proper flight is maintained (see diagram M).
- If your X5 drifts backwards, push and release the FORWARD/BACKWARD TRIM button forward in the same manner until the problem is resolved.

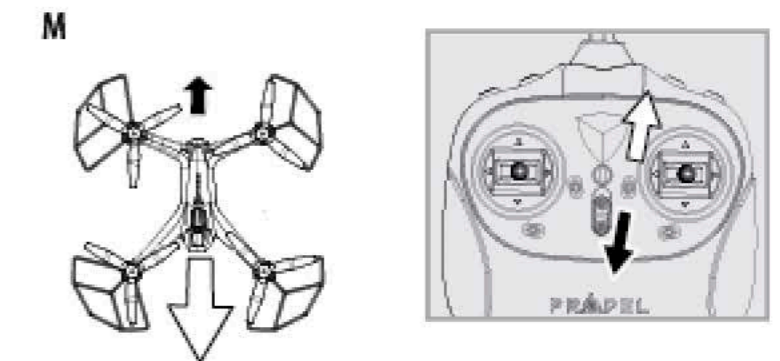

Bank Right/Left Trim

- If your X5 drifts / banks left while in the air, push and release the BANKS TRIM button to the right side repeatedly until the motion stops and proper flight is maintained (see diagram N).
- If your X5 drifts right, push and release the BANKS TRIM button to the left side in the same manner until the problem is resolved.

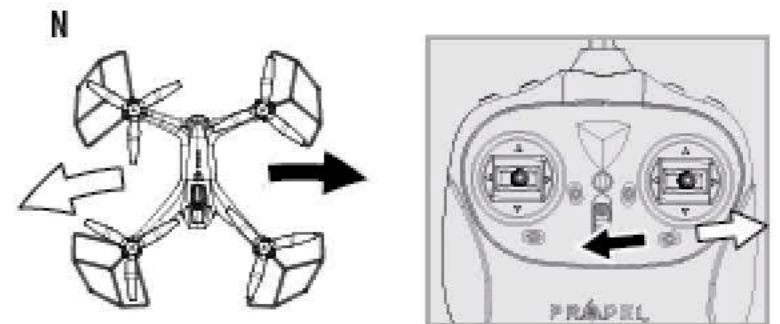

Spin Left Trim

- If your X5 spins left while in the air, push and release the LEFT/RIGHT TURN TRIM button to the right side repeatedly until the motion stops and proper flight is maintained (see diagram O).

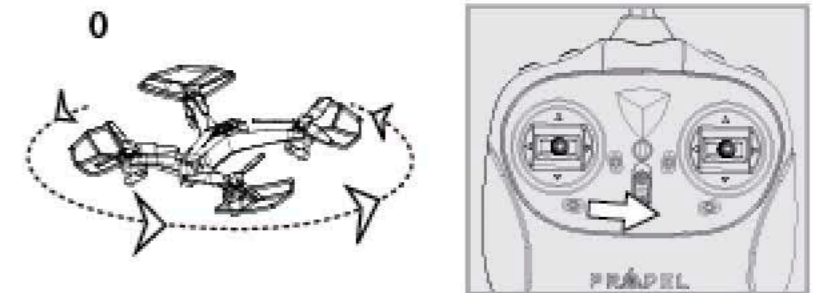

Spin Right Trim

- If your X5 spins right while in the air, push and release the LEFT/RIGHT TURN TRIM button to the left side until the problem is resolved (see diagram P).

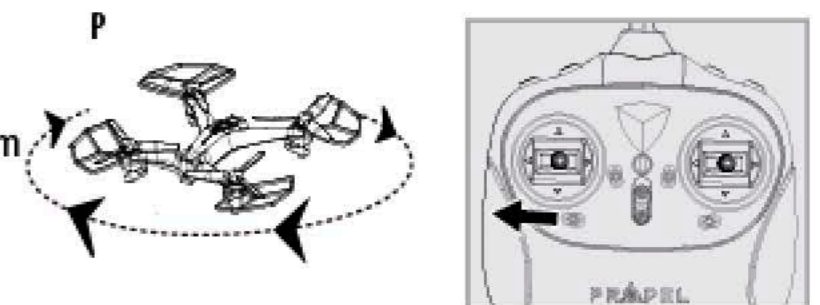

NOTE: The use of the Trim buttons utilizes sounds. A single long Beep indicates the product is center trimmed. If there is no beep sound after press the trim button, it indicates the maximum on a particular side.

CALIBRATING THE X5

NOTE: Your X5 comes pre-calibrated out of the box so you are ready to fly.

After several crashes and shock to your gyro sensors, you may notice that your drone is drifting and can not hold its center position as well as it used to.

This most likely means that you need to recalibrate your X5. Please follow the simple instructions below.

1. Place the X5 on a flat level surface.
2. Make sure the X5 is on and that the controller is synced (refer to syncing pg 4). Do not start the blades. Move both the throttle and control sticks down and to the left corner and hold them there for about 5 seconds (see diagram R). You will see the LED lights on the drone rapidly flash for a few seconds and then stay solid. Once the lights stop flashing you have completed your calibration and are ready to fly!

TROUBLE SHOOTING: If you do not see the lights flash, first remove the battery from the drone then turn off your controller and start again. Always make sure to put your battery in the X5 first, then turn on your controller. Push the left throttle stick up all the way and then pull back down again. When you hear the beep, the flashing blue lights (on the top center) and white lights (in the eyes) will turn solid. The X5 is synced to the controller. Now you can try to calibrate the X5 again.

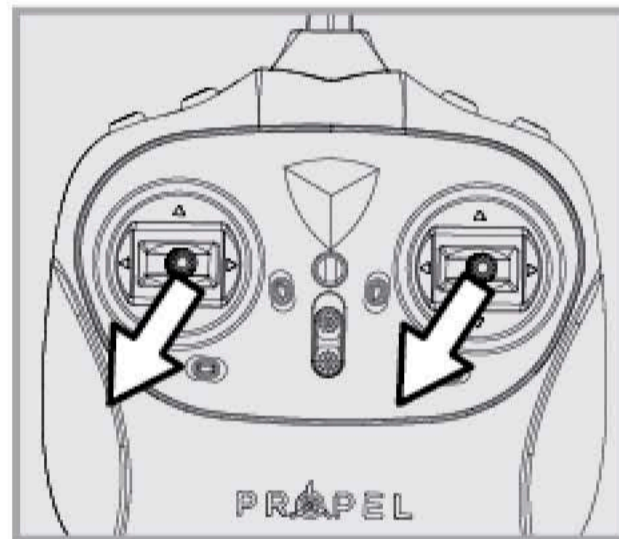

R

HOW TO PERFORM 360° STUNT ROLLS

Performing 360° stunt rolls with the X5 is as easy as 1-2-3:

1. Hover the X5 in still position making sure that you have at least 5 feet of clearance above and below the quadcopter. Set the speed settings to mode 2 or 3.
2. Press the 360 stunt button down and you will enter the stunt roll mode which is indicated by a rapid beeping (see diagram S).
3. Determine which direction you want it to flip and quickly push the right control stick in the direction you want to flip your X5 (see diagram T).
You have 4 choices a) Forward roll, b) Backwards roll, c) Right side roll, d) Left side roll.

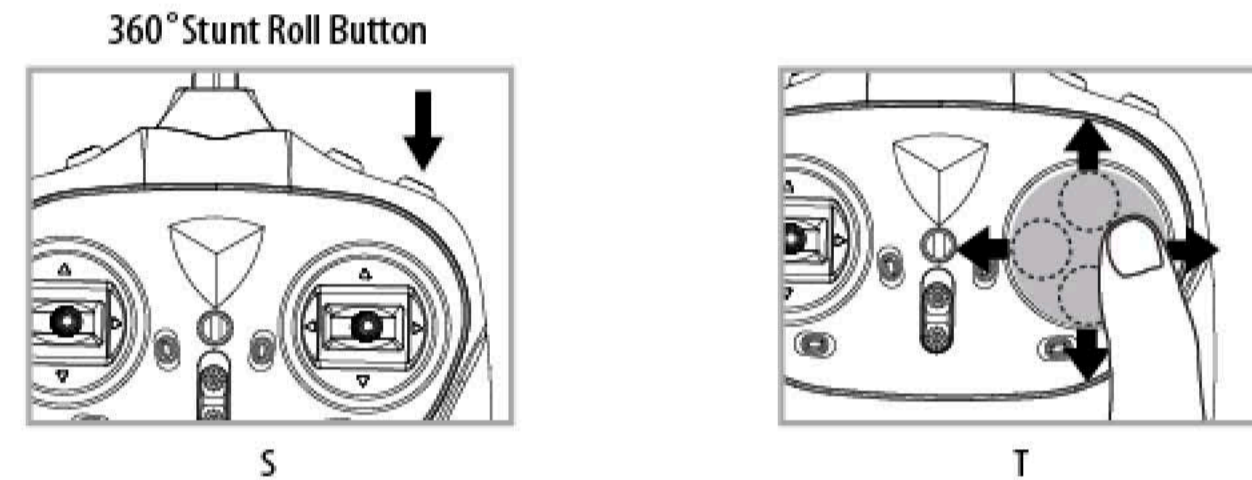

S

T

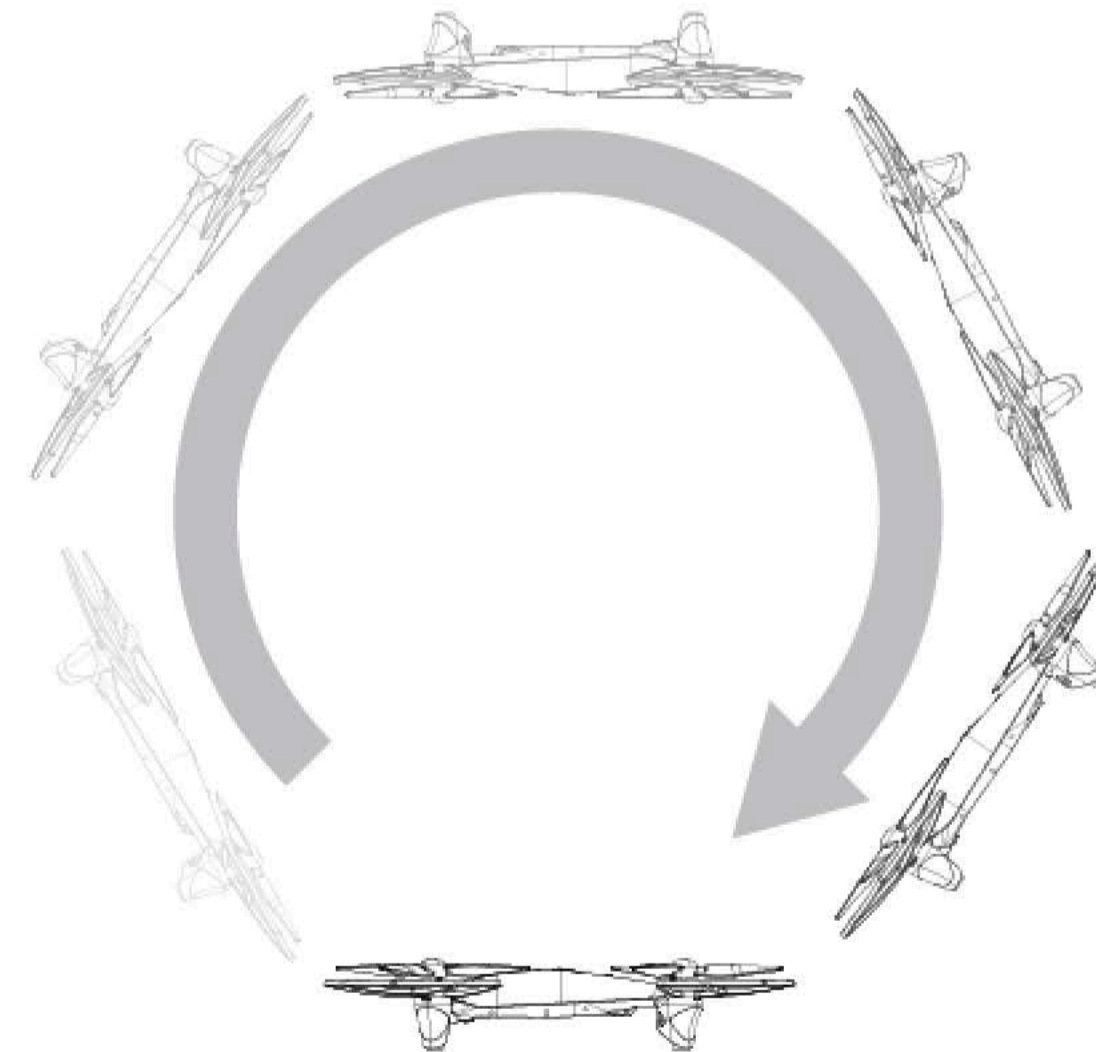

Note: To exit the stunt roll mode without flip, you can press the button again. The beeping sound will stop.

USING YOUR ON-BOARD CAMERA AND VIDEO RECORDER

Your X5 comes equipped with an onboard digital camera that takes both video and still photographs. Now you can have hours of fun creating aerial photography and videos for family and friends.

WHAT YOU WILL NEED TO GET STARTED USING YOUR CAMERA

1. One microSD card(not included).
2. One microSD card reader(included).
3. A Computer with a USB port and Windows Media Player or other Media player that can play AVI files(not included).

FORMATTING YOUR microSD CARD

Before you can begin to take videos or digital photographs you must first format your microSD card.To format your microSD card simply place the microSD card into the included USB SD card reader and plug it into your computers USB port (see diagram U1 and U2 below).After a few moments an icon will appear on your Desktop. Right click on the Icon and follow instructions to format your microSD card.

INSTALLING THE microSD CARD IN YOUR X5

- Pull the camera out from the drone. Place the formatted microSD card into the X5 SD card port (see diagram U3 below).Push gently until you hear and feel the microSD card“click”into the SD card slot. Then push the camera into the drone (see the Diagram U4).
- Turn the X5 on and make sure that it is both fully charged and properly synced to the controller (see HOW TO SYNC YOUR QUADROPTER on page 4).

NOTE:If you see a blue LED light flashing this indicates you have not installed your microSD card correctly or there is a problem with your SD card(see diagram U4 below). If this happens please reformat and try again.

TAKING DIGITAL PHOTOS

To take photographs short press the CAMERA button on the top right side of the controller (refer to CONTROLLER DIAGRAM on pg.3), when you push the button you will hear a "beep" and the red and white led lights on the will flash one time indicating that a picture has been taken.

RECORDING VIDEOS

To begin recording a video long press CAMERA button for 2 seconds.You will hear a "beep" and the red and white LED lights on the camera start flashing to indicate that you are in video mode and the camera is recording.To stop the video recording, long press the CAMERA button again.You will hear a“beep” indicating that the video recording has stopped and the Camera is in ready mode again.

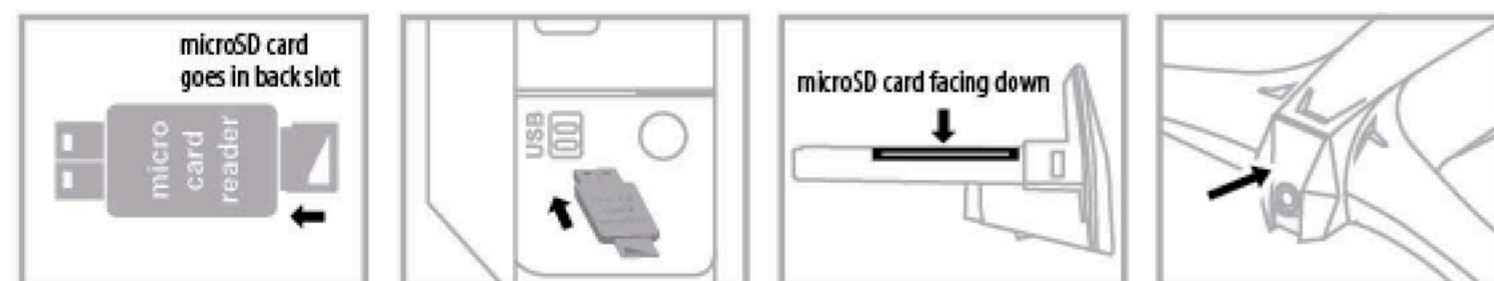

Diagram U1

Diagram U2

Diagram U3

Diagram U4

IMPORTANT NOTICE:You can not take photos and videos at the same time.When you are in video mode the photo function is disabled.If you want to take photos you must first exit video mode.It's recommend to test your camera functions before flying.

REMOVING YOUR microSD CARD

To remove your microSD Card push in gently on the back of the SD card with your thumb or forefinger until you hear and feel a “clicking sound”. The microSD card will “pop-out” slightly and is ready for removal. Simply grab and pull gently away from the X5's camera port to remove the card. Always store your microSD card in a clean, safe and cool environment.

DOWNLOADING AND CLEARING SPACE ON YOUR microSD CARD

Plug your microSD card into the microSD card reader and connect to your computer. It is best to always download all your videos and pictures on to your computer and not store this data on your microSD card. After downloading your photos and videos , follow your computers instructions to “delete” files on you microSD card.

IMPORTANT NOTICE: When your microSD card is full the indicator light on the bottom of your helicopter will not flash when you press the photo or video record buttons. This indicates that its time to put a new SD card in your X5 or download files and clear space for future photos and videos.

FCC RF exposure statements

This Transmitter must not be co - located or operating in conjunction with any other antenna or transmitter.

This equipment complies with FCC RF radiation exposure limits set forth for an uncontrolled environment. This equipment should be installed and operated with a minimum distance of 20 centimeters between the radiator and your body or nearby persons.

IC Radiation Exposure Statement:

This equipment complies with IC radiation exposure limits set forth for an uncontrolled environment. This equipment should be installed and operated with minimum distance 20cm between the radiator & your body.

Déclaration d'exposition aux radiations:

Cet équipement est conforme aux limites d'exposition aux rayonnements IC établies pour un environnement non contrôlé. Cet équipement doit être installé et utilisé avec un minimum de 20 cm de distance entre la source de rayonnement et votre corps.

PROPEL X5 WiFi APP INSTALLATION

1. Make sure you are using a compatible Android™ or Apple® iOS device.
2. Make sure your device has access to the Internet.
3. For Apple® iOS devices, within the App Store, search and select "Propel X5 WiFi". Hit the Install button and the "Propel X5 WiFi" App should download and install automatically.
4. For Android™ OS devices, visit the Google Play store and search for "Propel X5 WiFi". Selecting the "Propel X5 WiFi" App will download the App and automatically install it on your device.
5. After the "Propel X5 WiFi" App is installed, it should create an icon on your screen. Click the "Propel X5 WiFi" icon to run the App to make sure that it has installed correctly on your device. If not, please delete and repeat the process again.

PAIRING X5 TO YOUR COMPATIBLE DEVICE

1. After completely charging your X5 battery, install the battery to your X5 (refer to the user manual).
2. In the Settings menu of your device, locate the Wi-Fi option.
3. Turn ON the Wi-Fi option.
4. Select "Propel X5" from the Wi-Fi list. Wait for your X5 to be connected. Return to the Main Menu.

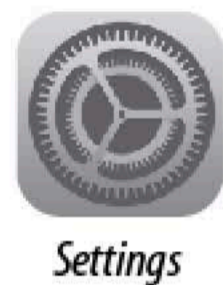

Note: Apple® devices require the use of iOS 7.0 or higher.
 ANDROID™ devices require the use of OS 4.2.2 or higher.

QUICK START

1. After you install the App correctly and have paired to the drone successfully, you can open the "Propel X5 WiFi" App icon. Tap "START" on the bottom right hand side of the screen. You should see the real-time video streaming from your X5's camera.
2. This App also allows you to control your X5 by your mobile device. To activate the control sticks, tap the "ON" button at the top right hand side of the screen. This will switch the control from your traditional controller to your compatible device. Now click "ON" to start the motors. The control sticks will show up in the screen for your fly control and you can now use your device as a traditional controller. Or you can click "LAUNCH" to auto launch your X5 in the air and then use your device as a traditional controller. Click this button again, your X5 will automatically land on the floor.

DETAILED APP OVERVIEW

3. Please see images below for a detailed App overview. This overview is also available under the "HELP" icon in the home screen of the App.

HOME PAGE



CONTROL STICKS



HELP PAGE 1



HELP PAGE 2



HELP PAGE 3

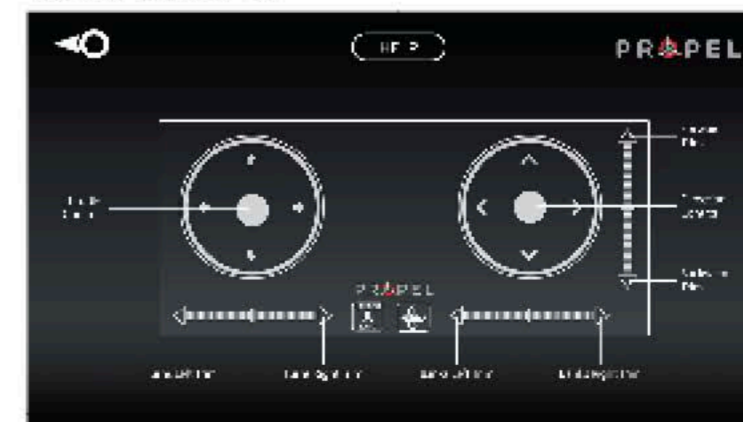

CAMERA SETTINGS

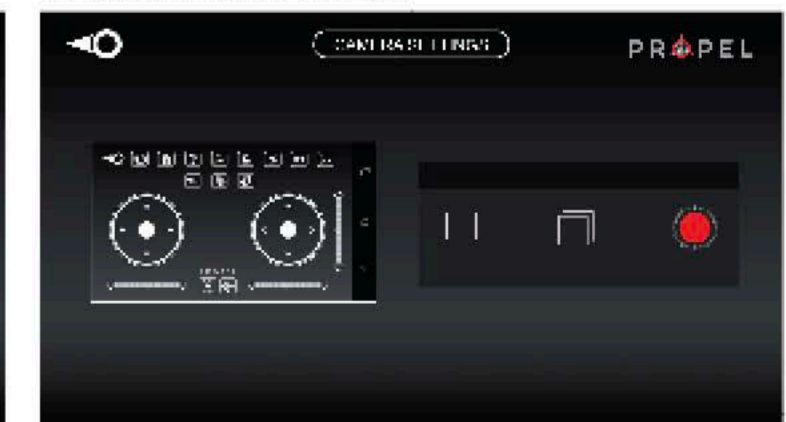

4. If you're still encountering difficulties please contact our customer service department at +1-949-566-9573(USA)

TROUBLESHOOTING YOUR X5

PROBLEM	POSSIBLE CAUSE	POSSIBLE SOLUTION
No Power	1. Power switched off 2. Polarity is reversed 3. Batteries may be low or in need of charging	1. Switch the ON/OFF switch to ON 2. Make sure all batteries are installed correctly (see diagram A) 3. Replace batteries
Aircraft Not Responding	1. Remote is switched off 2. Battery power in remote is too weak 3. The remote is not properly synced 4. Out of control range	1. Switch the ON/OFF switch to ON 2. Replace remote batteries 3. Re-sync the remote 4. Do not fly beyond 500 feet
Aircraft Won't lift off	1. Rotor speed too slow 2. Aircraft not fully charged 3. Obstruction of rotors	1. Push throttle lever forward 2. Recharge your X5 3. Check rotors for hair or other obstructions
Aircraft Descends Too Fast	1. Moving the throttle down too quickly 2. Flying in high wind or bad weather	1. Control the throttle slower/use auto land feature 2. Do not fly in bad weather

REPLACING THE PROPELLER BLADES

Your X5's propeller system is a precision instrument that may need repair or replacement from time to time for optimal flight function. Crash landing at high-speed may cause damage to your X5's propellers.

1. The X5 has 4 blades, each of them marked with "ℓ" or "ℓ̄".
2. To replace the damaged blade please follow the diagram V as below.
3. Unscrew from the top and then pull up to remove the damaged one.
4. Replace with a correct blade and secure it with screw from top again.

Blade Front Left = "ℓ"
Blade Front Right = "ℓ̄"

Blade Back Left = "ℓ̄"
Blade Back Right = "ℓ"

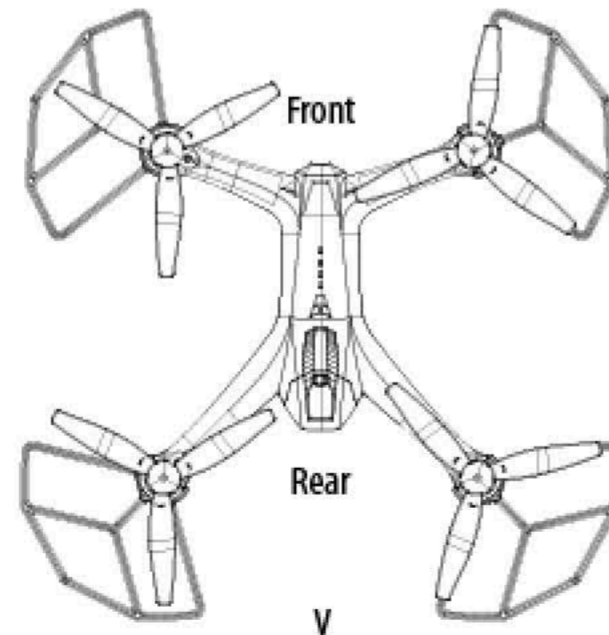

X5 WARNING:

The X5 is designed for OUTDOOR use. The X5's blades revolve at high speeds and can cause damage to the user, spectators and animals. Stand away from the X5 to reduce the risk of getting into the flight path. Warn spectators that you will be flying your X5 so that they are aware of its position. Before flight, inspect the rotor blades to make certain that the blades are securely fastened to the X5.

WARNING!

- Choking/Cutting Hazard. Small Parts/Sharp Rotor Blades.
- Keep hands, hair and loose clothing away from the propeller when the battery is plugged into the drone.
- Turn off the transmitter and X5 power switches when not in use.
- The included charger is built specifically for the X5 Li-Poly battery. Do not use it to charge any other battery.
- New alkaline batteries are recommended for maximum performance.
- Parental supervision recommended when flying X5.

BATTERY WARNINGS

RECHARGEABLE BATTERY:

This X5 uses a Li-Poly rechargeable battery. If battery can no longer be charged, dispose battery properly according to local law.

CONTROLLER BATTERIES:

Remote control requires 4 "AA" batteries (not included).

Please read the important battery safety warning below.

- Do not mix alkaline, standard (carbon-zinc) and rechargeable batteries (Nickel Metal Hydride).
- Do not mix old and new batteries.
- Non-rechargeable batteries are not to be recharged.
- Rechargeable batteries are to be removed from the item before being charged (if removable).
- Rechargeable batteries are only to be charged under adult supervision.
- Exhausted batteries should be removed immediately and must be recycled or disposed of properly according to state or local government ordinances and regulations.
- The supply terminals are not to be short-circuited.
- Only batteries of the same or equivalent type as recommended are to be used.
- Batteries are to be inserted with the correct polarity (see inside booklet for diagram).
- Do not dispose batteries in a fire - batteries may leak or explode.

CARE AND MAINTENANCE

- Always remove the batteries from the wireless remote control when it is not being used for an extended period of time.
- To clean, gently wipe the remote control and X5 with a clean damp cloth.
- Keep the toy away from direct heat or sunlight.
- Do not submerge the toy into water. This can damage the unit beyond repair.
- Parental guidance recommended when installing or replacing the batteries.

IMPORTANT! REGISTER YOUR DRONE

The U.S. Department of Transportation's Federal Aviation Administration (FAA) announced a streamlined and user-friendly web-based aircraft registration process for owners of small unmanned aircraft (UAS) weighing more than 0.55 pounds (250 grams) and less than 55 pounds (approx. 25 kilograms) including payloads such as on-board cameras.

Owners can get more info and may register through a web-based system at www.faa.gov/uas/registration

Flying for fun? **New rules for recreational drone users**
It's now the law! If you fly your drone for fun and it weighs more than **250 g** and up to **35 kg**, follow these new rules.

Do not fly your drone in below circumstances:

- higher than 90 m above the ground
- closer than 75 m from buildings, vehicles, vessels, animals, people/crowds, etc.
- closer than 9 km from the centre of an aerodrome (any airport, heliport, seaplane base or anywhere that aircraft take-off and land)
- within controlled or restricted airspace
- within 9 km of a forest fire
- where you could interfere with police or first responders
- at night or in clouds
- if you can't keep it in sight at all times
- if you are not within 500 m of your drone
- if your name, address and telephone number are not clearly marked on your drone.

If you do not follow these rules, you could put lives, aircraft, and property at risk, and face fines of up to \$3,000.

Consult the [safety measure](#) for the full list of rules.

Canada.ca/drone-safety

IMPORTANT! INSCRIVEZ VOTRE DRONE

Le U.S. Department of Transportation's Federal Aviation Administration (FAA) a annoncé un processus simplifié et convivial d'inscription d'aéronefs sur le Web pour utilisateurs de petits aéronefs sans pilote (UAS) qui pèsent plus de 0,55 livre (250 grammes) et moins de 55 livres (environ 25 kilogrammes) y compris les charges utiles comme des caméras à bord.

Les utilisateurs peuvent obtenir plus de renseignements et ils peuvent s'inscrire par l'entremise d'un système sur le Web à www.faa.gov/uas/registration

Vous exécutez des vols pour vos loisirs? **Nouveaux règlements pour utilisateurs de drones dans un but récréatif.**
C'est maintenant la Loi! Si vous exécutez des vols avec votre drone pour vos loisirs et que celui-ci pèse plus de **250 g** et juste qu'à **35 kg**, veuillez suivre ces nouveaux règlements.

N'exécutez aucun vol avec votre drone dans les circonstances ci-dessous :

- plus haut que 90 m au-dessus du sol
- une approche à moins de 75 m des bâtiments, des véhicules, des vaisseaux, des animaux, des personnes, des foules, etc.
- une approche à moins de 9 km du centre d'un aérodrome (tout aéroport, héliport, hydrobase ou bien de n'importe où un aéronef décolle et atterrit)
- à l'intérieur d'un espace aérien contrôlé ou réglementé
- dans un rayon de 9 km d'un feu de forêt
- là où vous pourriez interférer avec la police ou des premiers intervenants
- la nuit ou dans des nuages
- s'il vous est impossible de le garder en vue en tout temps
- si vous n'êtes pas situé à moins de 500 m de votre drone
- si vos nom, adresse et numéro de téléphone ne sont pas marqués clairement sur votre drone.

Si vous ne suivez pas ces règlements, vous pouvez mettre en danger, des vies, des aéronefs, des propriétés et vous exposer à des amendes allant jusqu'à 3 000 \$.

Veuillez consulter la [mesure de sécurité](#) pour obtenir la liste complète des règles.

Canada.ca/sécurité—drone