

8.25"



# 4G LTE CellSpot™ Quick Start Guide

You now have a powerful, simple way to create your own personal T-Mobile 4G LTE mini-tower in your home or small office. It can provide improved indoor 4G LTE coverage, more dependable voice calls and more consistent data speeds.

11.7"



### Attention: Important Information

This device must be installed at your registered address with T-Mobile. Failure to maintain this address could affect your ability to contact emergency services and result in device deactivation. Visit <https://my.t-mobile.com>, MyAccount on your handset or call CARE at \*611 from your handset or 1-800-937-8997 to update the device use address.

FRONT COVER



55 Union Street | 3rd Floor  
San Francisco, CA 94111  
T 415 427 1200 | F 415 348 0063  
sterlingbecker.com

### MECHANICAL

FILE NAME  
RM2\_4GPersonalCellSpot\_QSG\_TCS525167\_1.ai

DATE 12.04.14	DRAWN BY vl	SB JOB NUMBER 1600634
CLIENT T-Mobile	PRINTER TBD	PRINTING TYPE TBD
DIELINE FILE NAME 8.25" wide x 11.7" tall	DIELINE SOURCE Drawn by SB	DIELINE DATE n/a
CREATIVE APPROVAL	PRODUCTION APPROVAL	PROOFREADING APPROVAL

### PRINTING STATIONS:

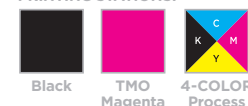

### PROCESS MIX:

### NOTES:

8.25"

## What's Inside



**Quick Start Guide**  
(This document)



**4G LTE CellSpot Device**

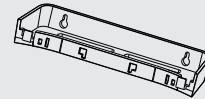

**Stand/Wall Mount**



**Wall Mounting Kit**  
(2 Cheese Screws and  
2 Wall Anchors)



**AC Power Adaptor**

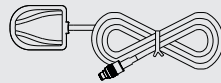

**GPS Antenna & Cable (15 ft)**



**Ethernet Cable**

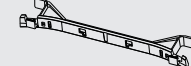

**GPS Cable Bracket**

## Getting to know your 4G LTE CellSpot™

### CellSpot Device in Stand

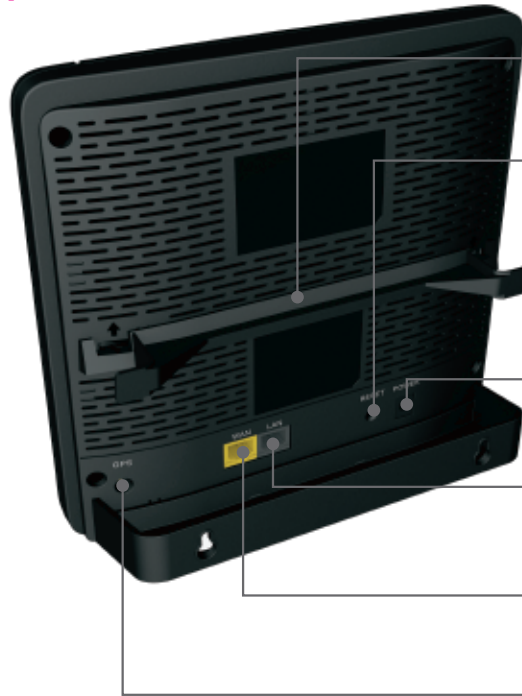

**GPS Cable Bracket**

(Attach GPS cable here after installation is complete)

**Reset**

1. Press and hold for 5s for reboot
2. Press and hold for 10s for power off
3. Press and hold for 15s for factory setting reset and software update

**Power**

(Power on when AC Adaptor is plugged in)

**Grey LAN Port**

(Connect to other devices if needed)

**Yellow WAN Port**

(Connect to Wi-Fi router or Wi-Fi cable modem router)

**Round GPS Port**

(Connect to GPS Antenna & Cable)

### CellSpot Device with Wall Mount

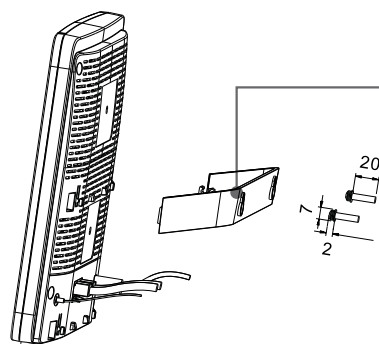

**Stand/Wall Mount**

**Wall Mounting Kit**

1

11.7"

INSIDE - LEFT

## Quick Setup

### 1 Connect your CellSpot to the Internet

Connect the yellow Ethernet cable from the "WAN" yellow port on your CellSpot to an available Ethernet port on your Wi-Fi router or Wi-Fi cable modem router.

### 2 Connect GPS antenna to the CellSpot

Connect the GPS antenna cable to the GPS port. Position the antenna as close to a window as possible. (You'll attach the GPS antenna and cable to the bracket after installation is complete.)

### 3 Power on your 4G LTE CellSpot

Plug in your AC power adaptor into the power outlet and connect the power cable to the CellSpot power port.

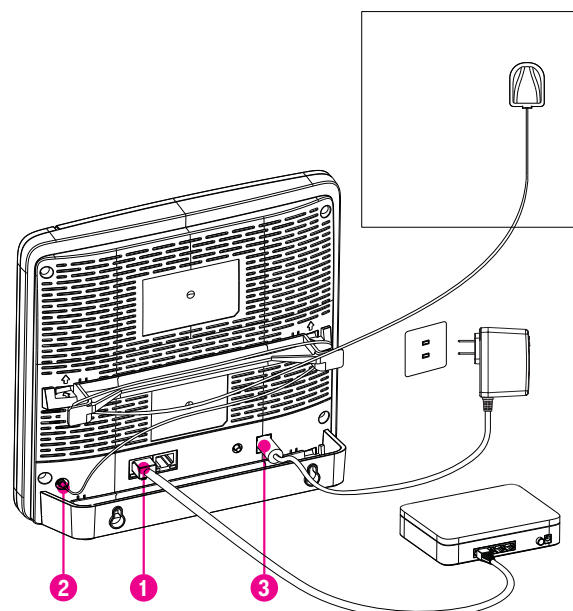

### 4 Let your CellSpot set up

After you power on your CellSpot, the CellSpot will go through self-installation process. It can take up to 45 minutes to complete the device setup. Your CellSpot may download updates and could restart during this time.





























- **Power** (Solid Green): Power on. Device self testing and update complete.
- **Internet** (Solid Green): Successful internet connection.
- **Status** (Solid Green): Successful connection established with T-Mobile network.
- **GPS** (Solid Green Optional): GPS position locked if GPS signal is present. Device can still proceed through setup without GPS signal lock and operate normally.
- **3G/4G** (Solid Green): Device is ready to provide 3G/4G service.
- **4G LTE** (Solid Green): Device is ready to provide 4G LTE service.



Congratulations! Your CellSpot setup is complete.

Make your first 4G LTE CellSpot call with your 3G, 4G or 4G LTE capable devices. Just use your mobile device as you normally do and enjoy the improved coverage, more dependable voice calls and a more reliable high speed data connection.

## Common Troubleshooting Procedures

Issue Description and Resolution	Power	Internet	Status	GPS	3G/4G	4G LTE
Device has a hardware issue. Contact T-Mobile for resolution.	 Solid Orange	 Solid Orange	 Solid Orange	 Solid Orange	 Solid Orange	 Solid Orange
Device unable to capture GPS signal. Without GPS signal lock, device is still able to proceed through setup and operate normally.	Any	Any	Any	 Solid Orange	Any	Any
Device connection issue with the Wi-Fi router or Wi-Fi cable modem router. Check Wi-Fi router or Wi-Fi cable modem router connection.	 Flashing Green	 Solid Orange	Off	Any	Off	Off
Device is unable to reach T-Mobile network. Check with Internet Service Provider on network settings. Ensure ports UDP 500, UDP 4500 and UDP 123 are opened.	 Flashing Green	 Flashing Orange	Off	Any	Off	Off
Unable to activate the device with T-Mobile network. Contact T-Mobile for resolution.	 Flashing Green	 Solid Green	 Solid or Flashing Orange	Any	Off	Off
3G, 4G, 4G LTE service is not available. Device may not be used in T-Mobile market or remote disabled by T-Mobile. Contact T-Mobile for resolution.	 Solid Green	 Solid Green	 Solid or Flashing Green	Any	Off	Off
Device has reached maximum number of 8 active voice and data connections for each technology. Attempt to call again after existing calls are terminated.	 Solid Green	 Solid Green	 Flashing Green	Any	 Flashing Green	 Flashing Green
The device is overheated. Move device to a cooler location	 Flashing Orange	 Flashing Orange	 Flashing Orange	 Flashing Orange	 Flashing Orange	 Flashing Orange

### Have More Questions?

For additional information about T-Mobile 4G LTE CellSpot installation go to <http://4GLTECellSpotSetup.T-Mobile.com>  
Call T-Mobile customer service at \*611 from your handset or 1-800-937-8997.

Deposit, qualifying wireless service, compatible phone & broadband Internet connection required. May require plan change. All data, messaging and other services billed according to your regular rate plan and other pricing. Non-return fee applied if device is not returned; damage fee may apply.  
**Current location address required for device use.** See T-Mobile.com for details and restrictions including important 9-1-1 limitations.  
Property of T-Mobile USA, Inc. Not For Resale. TCS525167.1

