

# TCG310

USER MANUAL

SAFETY INSTRUCTIONS AND REGULATORY NOTICES .....	5
Chapter 1: Connections and Setup .....	10
Cable Modem Overview .....	10
Front Panel .....	10
Rear Panel .....	12
Bottom Side Panel for TEL .....	13
Wall Mounting .....	14
Relationship among the Devices.....	15
What the Modem Does .....	15
What the Modem Needs to Do Its Job .....	15
Contact Your Local Cable Company .....	16
Connecting the Wireless Voice Gateway to a Single Computer .....	16
Attaching the Cable TV Wire to the Wireless Voice Gateway .....	17
Installation procedure for connecting to the Ethernet interface .....	18
Telephone or Fax Connection .....	19
Chapter 2: WEB Configuration.....	20
Accessing the Web Configuration (For basic account only) .....	20
Overview Web Page Group .....	22
Overview .....	22
Internet Web Page Group.....	23
Parental Control.....	23
Wi-Fi Web Page Group.....	24
General .....	24
Guest Network .....	29
WPS.....	33
Wi-Fi Clients.....	34
Wi-Fi Radar.....	35
Reset .....	36
Settings Web Page Group.....	37
Language .....	37
Password.....	38
Configuration .....	39

LAN .....	40
LED .....	41
MoCA Web Page Group .....	42
MoCA .....	42
Status Web Page Group .....	43
Status .....	43
Voice Status .....	44
Up/Down Stream .....	45
Event log .....	46
Accessing the Web Configuration (For admin account only) .....	47
Internet Web Page Group .....	47
Advanced .....	47
Port Mapping .....	49
Firewall .....	50
IP Filtering .....	51
Port Filtering .....	52
DMZ Host .....	53
Dynamic DNS .....	54
DNS Cache .....	55
UPnP .....	56
RIP Setup .....	57
Bridge Mode .....	58
Diagnostic .....	59
MAC base Passthrough .....	60
Wi-Fi Web Page Group .....	61
Schedule .....	61
MAC Filter .....	62
WMM (Wi-Fi Multi-Media) .....	63
Settings Web Page Group .....	64
Remote Access .....	64
Internet Time .....	65



USB Web Page Group .....	66
USB Basic .....	66
Media Server .....	67
CPUS Server.....	68
Chapter 3: Additional Information .....	69
Frequently Asked Questions .....	69
General Troubleshooting .....	70
Service Information.....	71
Federal Communication Commission Interference Statement .....	72
Industry Canada statement: .....	74
CAUTION for UL (Check caution label on gift box) .....	76

# SAFETY INSTRUCTIONS AND REGULATORY NOTICES



## Product Safety Notice

Before installing or using the product, read these instructions carefully. Be sure to comply strictly precautions.

- **Explanation of risk levels**

 DANGER	This indication is given where there is an immediate danger of death or serious injury if the person in charge or any third party mishandles the machine or does not avoid the dangerous situation when operating or maintaining the machine.
 WARNING	This indication is given where there is a potentiality for death or serious injury if the person in charge or any third party mishandles the machine or does not avoid the dangerous situation when operating or maintaining the machine.
 CAUTION	This indication is given where there is a danger of medium to minor injury if the person in charge or any third party mishandles the machine or does not avoid the dangerous situation when operating or maintaining the machine.

- **Explanation of pictorial warning indications and warning labels**

 Prohibited	It is used to prohibit its conduct in handling products. Specific prohibited contents are indicated by pictures and sentences in or near the figure symbol.
 Caution	It is used to call attention to ignition, electric shock, high temperature, etc. in the handling of products. Specific notes content is indicated by a picture or sentence in or near the figure symbol.
 Instruction	Used to force actions based on instructions in the handling of products. Specific instruction content is indicated by a picture or sentence in or near the figure symbol.

## ● LIMITATIONS OF LIABILITY

This equipment has been designed for domestic use inside a building. In some environments or circumstances, the use of wireless devices may be prohibited by the owner of the building or responsible representatives of the organization. If in doubt about the policy applying to the use of wireless devices in an organization where a specific environment (e.g. airports), you should ask for permission to use the device before turn it on. ASKEY assumes no liability for non-compliance with regulations on the installation site, and radio interference created vis-à-vis third parties and due to non-compliance with national regulations for this application.



## DANGER



Instruction

Do not overload wall outlet or extension cords as this may increase the risk of electric shock or fire. If the power cord is frayed, replace it with a new one.



Instruction

Do not attempt to connect with any computer accessory or electronic product without instructions from qualified service personnel. This may result in risk of electronic shock or fire.



## WARNING



Instruction

Proper ventilation is necessary to prevent the product overheating. Do not block or cover the slots and openings on the product, which are intended for ventilation and proper operation.



Unplug the power plug

When the product is expected to be not in use for a period of time, unplug the power cord of the product to prevent it from the damage of storm or sudden increases in rating.



Unplug the

Accidental penetrations of small metal objects (such as pins, paper clips, etc.) disconnect the equipment from the mains as soon as possible (risk of electric shock) and contact your Customer Service to find out how to proceed. Do not reconnect the product as a foreign object has not been eliminated. Unplug the product immediately if you notice it exudes a smell

---

power plug

of burning or smoke. You should never open the unit yourself because you could be electrocuted.

---



Prohibited

Do not place the product near any source of heat or expose it to direct sunlight.

---



Water wet prohibition

Do not expose the product to moisture. Never spill any liquid on the product.

---



Instruction

Avoid connecting or using this product during a lightning storm. Disturbances transmitted through the grid and / or telephone can cause electric shock in the product and people.

---



## CAUTION

---



Instruction

Use only power adapter supplied with the product. This appliance is designed to operate in the rated voltage 110~240 VAC.

---



Instruction

Do not place this product on unstable stand or table.

---



Instruction

This product is designed for stationary use in an office or a room in the home for a maximum ambient temperature of 40 ° C (104 ° F).

---



Instruction

To allow the disconnection of the device in case of problems, make sure the base of the outlet you plug the power cord is easily accessible and is located as close as possible to the equipment.

---



Leave 7cm to 10cm around the appliance to ensure that proper ventilation gets to it.

Instruction

---



Be sure to connect the ground wire

The screen of the coaxial cable is intended to be connected to earth in the building installation.

---



Disassembly prohibited

Do not attempt to disassemble or open covers of this unit by yourself. Nor should you attempt to service the product by yourself, which may void the user's authority to operate it. Contact qualified service personnel under the following conditions:

1. If the power cord or plug is damaged or frayed.
  2. If liquid has been spilled into the product.
  3. If the product has been exposed to rain or water.
  4. If the product does not operate normally when the operating instructions are followed.
  5. If the product has been dropped or the cabinet has been damaged.
  6. If the product exhibits a distinct change in performance.
  7. If a cable is damaged or frayed provided.
  8. If the unit is dropped or damaged in any way.
  9. If there is a noticeable signs of overheating
- 



Unplug the power plug

Power off and unplug this product from the wall outlet when it is not in use or before cleaning. Pay attention to the temperature of the power adapter. The temperature might be high.

---



Instruction

Do not store the Cable Modem product in excessively hot, cold or damp conditions. Operation Environmental:

- Operation Temperature: 5°C ~ 40°C
  - Storage Temperature: -20°C ~ +70°C
- 



To clean the appliance, use a dry, clean soft cloth with no cleaning solvent or abrasive products. Clean the ventilation openings regularly.

---



---

Instruction

---

# CHAPTER 1: CONNECTIONS AND SETUP

## Cable Modem Overview

### Front Panel

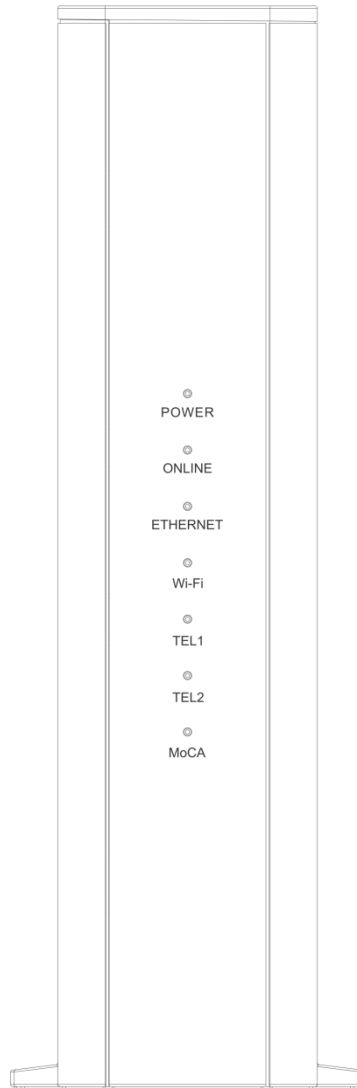

Fig. 1-1 Front Panel

<b>POWER</b>	Indicates the power status.
<b>ONLINE</b>	Displays the status of your cable connection. The light is off when no cable connection is detected and fully lit when the modem has established a connection with the network and data can be transferred.
<b>ETHERNET</b>	Indicates the state of Ethernet ports.
<b>Wi-Fi</b>	Indicates the traffic on the wireless network.
<b>TEL 1 / 2</b>	Indicates the status of the telephone ports.
<b>MoCA</b>	Indicates the status of the MoCA functionality.

LED from top to bottom.

<b>LED</b>	<b>Status</b>	<b>Description</b>
POWER	ON	The device is on.
	OFF	The device boot fail or no power.
ONLINE	ON	The device is ready for use. Now you can link to the internet.
	OFF	The device is not link to the internet yet or not registration.
	FLASH	The device is in registration process or upgrade firmware.
ETHERNET	ON	LAN port is connected to the PC.
	OFF	LAN port is not connected to the PC.
	FLASH	Traffic on the LAN is working.
Wi-Fi	ON	Wi-Fi is enabled.
	OFF	Wi-Fi is disabled.
	FLASH	Wi-Fi traffic is working.
TEL 1 / 2	ON	Phone is ready registration for use.
	OFF	Phone is not able to use.
	FLASH	Phone interface is in registration process.
MoCA	ON	MoCA is enabled.
	OFF	MoCA is disabled.
	FLASH	MoCA traffic is working.

Table 1-1 LED behavior

## Rear Panel

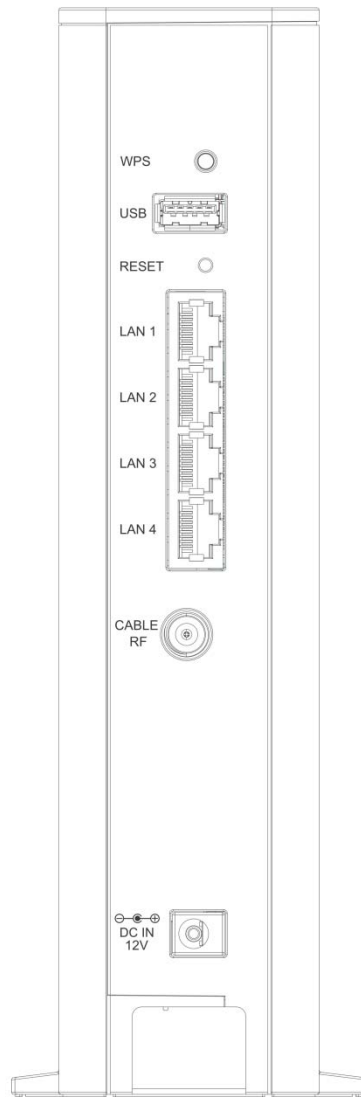

Fig. 1-2 Rear Panel

Slot	Description
WPS	Enables scanning for available WPS client device
USB	USB 3.0 host connector
RESET	Reset/Reboot this Cable modem
LAN 1 / 2 / 3 / 4	Ethernet 10/100/1000 Base-T RJ-45 connector
CABLE RF	F-Connector
12VDC	12V DC-IN Power connector.

Table 1-2 Rear Panel description

**Bottom Side Panel for TEL**

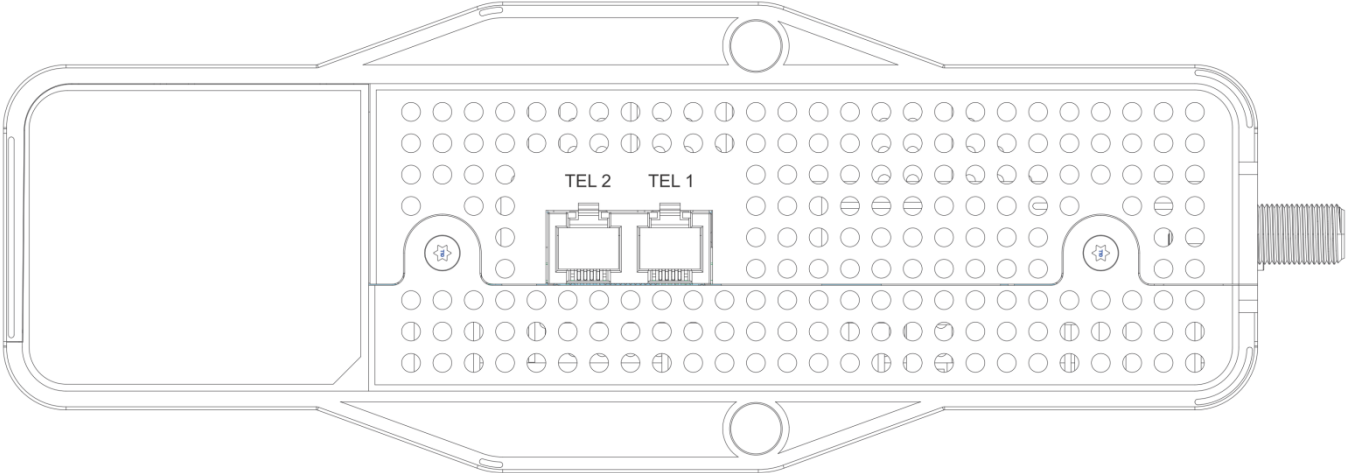

Fig. 1-3 Bottom Side Panel

The TEL 1 / 2 on the Bottom Side panel of TCG310, you can use telephony RJ-11 Connector.

## Wall Mounting

The number of the screw 2 pcs.

Direction for wall mounting: Tuner downward or leftward or rightward.

Dimension for the screw: diameter: 3.5 mm; length: 30 mm.

There are 2 slots on the side of the CABLE MODEM that can be used for wall mounting.

---

**Note: When wall mounting the unit. Ensure that it is within reach of the power outlet.**

---

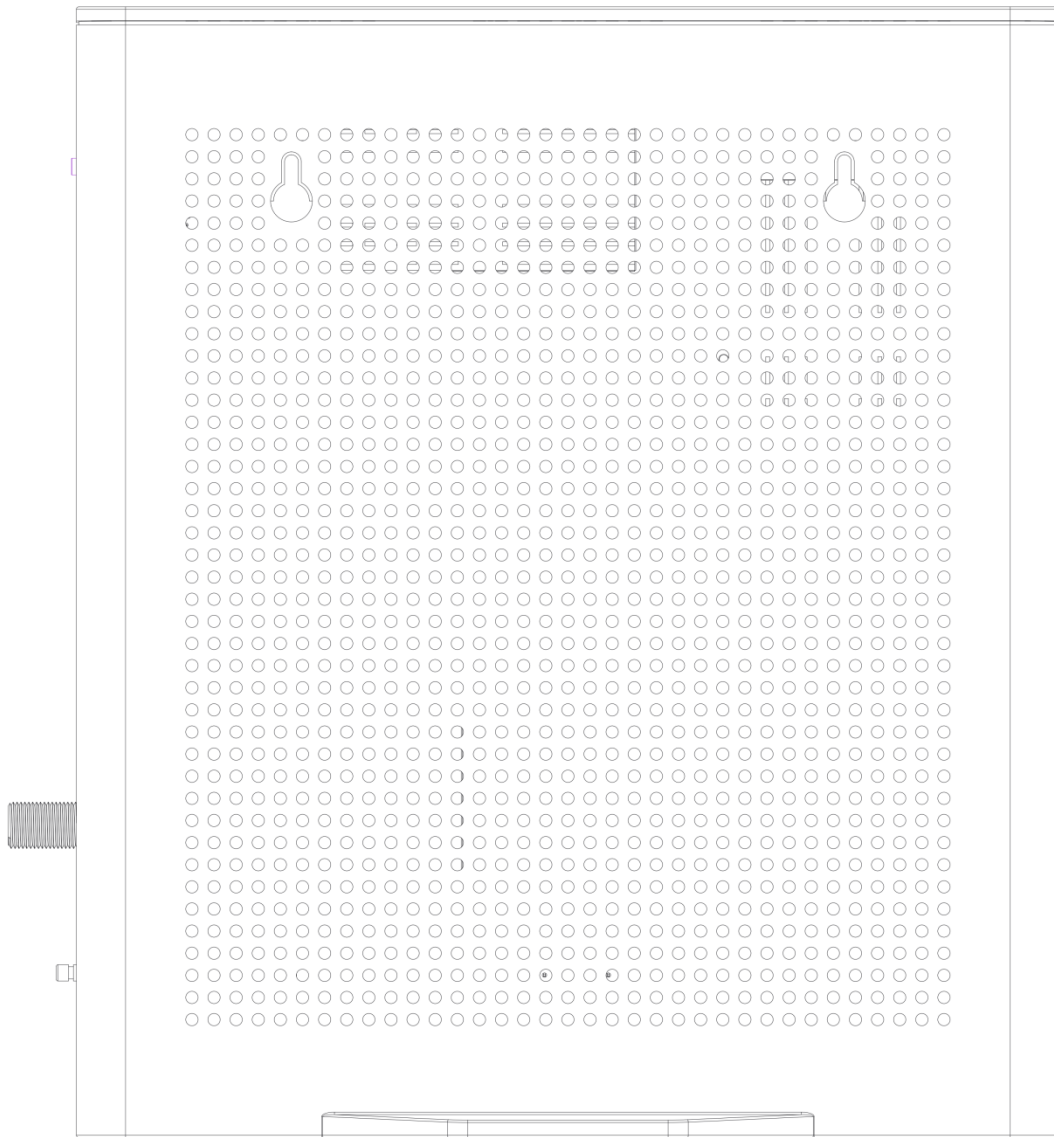

Fig. 1-4 Wall Mounting

### To do this:

1. For the cable modem, ensure that the wall you use is smooth, flat, dry and sturdy and use the 2 screws holes.
2. The unit can be to use solid concrete wall and/or hard wood wall.

## Relationship among the Devices

---

This illustration shows a cable company that offers DOCSIS/Euro-DOCSIS and PacketCable/Euro-PacketCable compliant voice/data services.

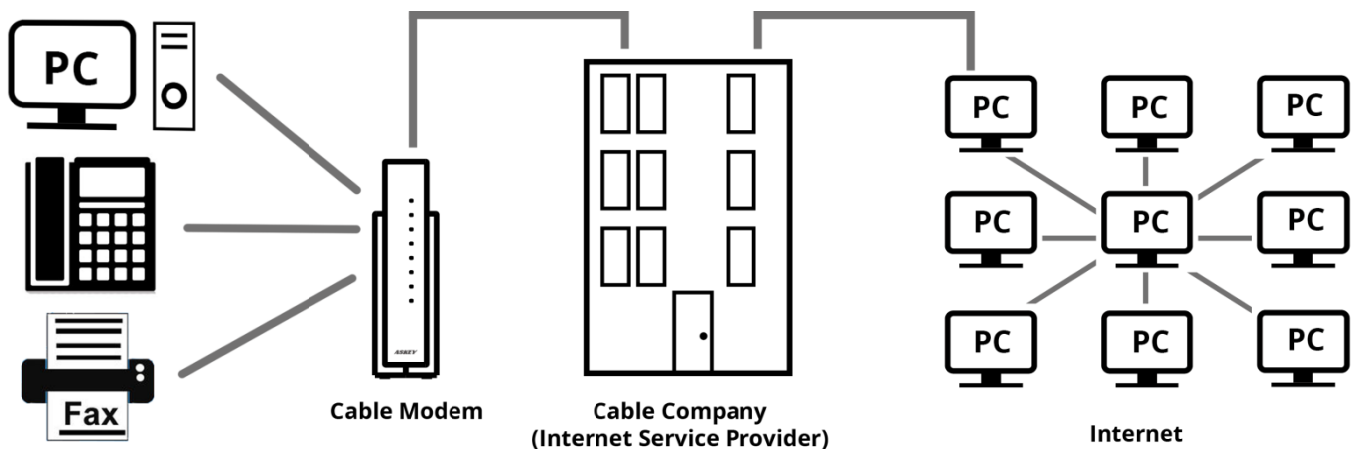

Fig. 1-5 Connection overview

### What the Modem Does

The Wireless Voice Gateway provides high-speed Internet access as well as cost-effective, toll-quality telephone voice and fax/modem services over residential, commercial, and education subscribers on public and private networks via an existing CATV infrastructure. It can inter-operate with the PacketCable compliant head-end equipment and provide the IP-based voice communications. The IP traffic can transfer between the Wireless Voice Gateway and DOCSIS/Euro-DOCSIS compliant head-end equipment. The data security secures upstream and downstream communications.

### What the Modem Needs to Do Its Job

- **The Right Cable Company:** Make sure your local cable company provides data services that use cable TV industry-standard DOCSIS/Euro-DOCSIS compliant and PacketCable/Euro-PacketCable compliant technology.
- **The Internet/Telephony Service Provider (ISP/TSP):** Your cable company provides you access to an Internet Service Provider (ISP) and Telephony Service Provider (TSP). The ISP is your gateway to the Internet and provides you with a pipeline to access Internet content on the World Wide Web (WWW). The TSP provides you with telephony access to other modems or other telephony services over the Public Switched Telephone Network (PSTN).

Check with your cable company to make sure you have everything you need to begin; they'll know if you need to install special software or re-configure your computer to make your cable internet service work for you.

## **Contact Your Local Cable Company**

You will need to contact your cable company to establish an Internet account before you can use your gateway. You should have the following information ready (which you will find on the sticker on the gateway):

- The serial number
- The model number
- The Cable Modem (CM) Media Access Control (MAC) address
- The Terminal Adapter (EMTA) MAC address
- Security information: Service Set Identifier (SSID), Encryption key / passphrase (WPA2-PSK by default), channel number. Default values are indicated underneath the modem on the sticker.

### **Please check the following with the cable company**

- The cable service to your home supports DOCSIS/Euro-DOCSIS compliant two-way modem access.
- Your internet account has been set up. (The Media Terminal Adapter will provide data service if the cable account is set up but no telephony service is available.)
- You have a cable outlet near your PC and it is ready for Cable Modem service.

Note: It is important to supply power to the modem at all times. Keeping your modem plugged in will keep it connected to the Internet. This means that it will always be ready whenever you need.

## **Important Information**

Your cable company should always be consulted before installing a new cable outlet. Do not attempt any rewiring without contacting your cable company first.

### **Please verify the following on the Wireless Voice Gateway**

The Power LED should be lighted when plug-in the power supply.

## **Connecting the Wireless Voice Gateway to a Single Computer**

This section of the manual explains how to connect your Wireless Voice Gateway to the Ethernet port on your computer and install the necessary software. Please refer to Figure 1-7 to help you connect your Digital Cable Modem for the best possible connection.



## Attaching the Cable TV Wire to the Wireless Voice Gateway

1. Locate the Cable TV wire. You may find it one of three ways:
  - a. Connected directly to a TV, a Cable TV converter box, or VCR. The line will be connected to the jack, which should be labeled either IN, CABLE IN, CATV, CATV IN, etc.
  - b. Connected to a wall-mounted cable outlet.
  - c. Coming out from under a baseboard heater or other location. See Figure 1-6 for the wiring example.

**Notes:** For optimum performance, be sure to connect your Wireless Voice Gateway to the first point the cable enters your home. The splitter must be rated for at least 1GHz.

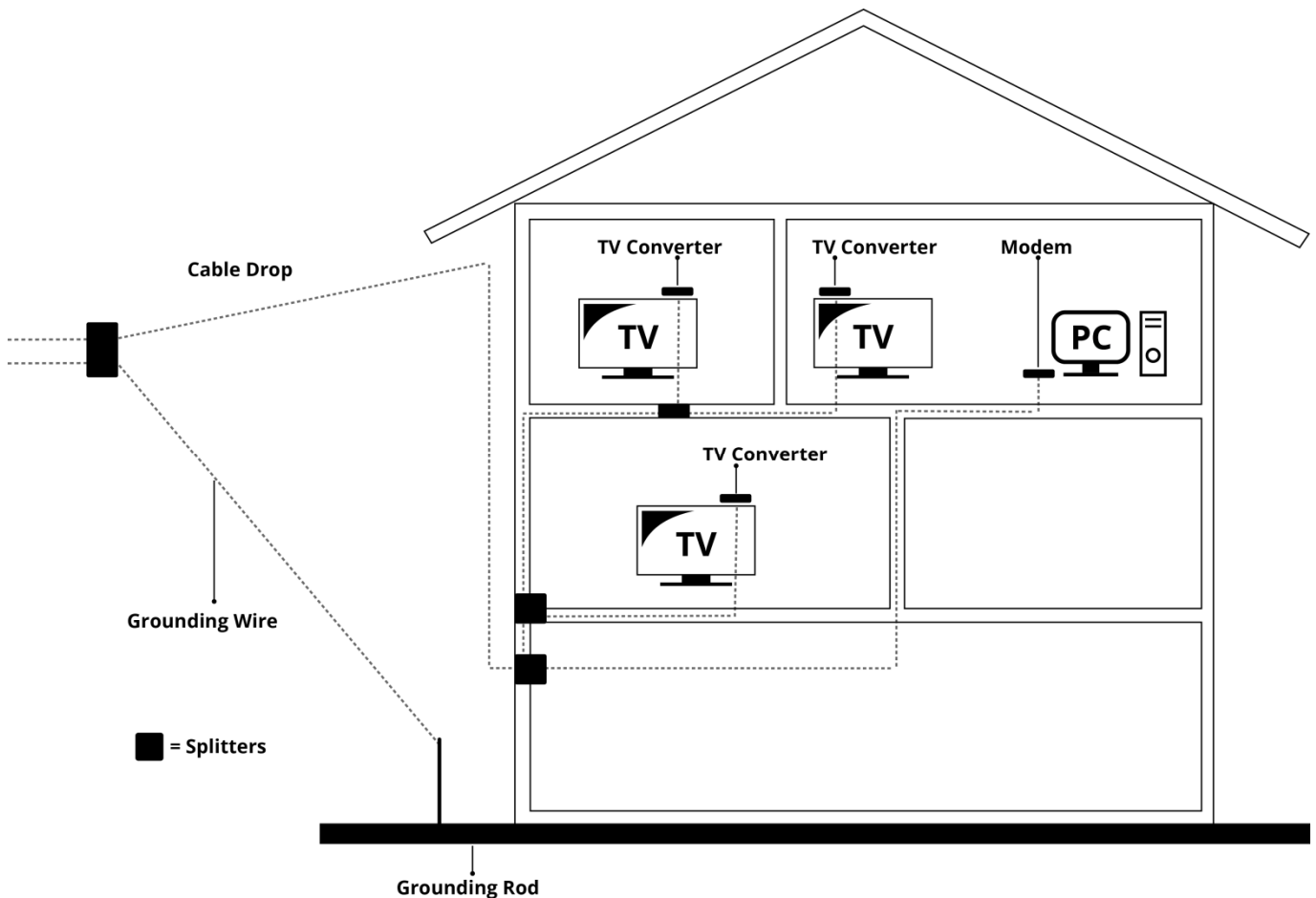

Fig. 1-6 Basic Home Wiring

## Installation procedure for connecting to the Ethernet interface

Follow these steps for proper installation. (Please refer to Fig. 1-7)

Plug the coaxial cable to the cable wall outlet and the other end to the modem's cable connector.

---

**Note: To ensure a fast registration of the modem, the coaxial cable must be connected to the modem before it is powered on.**

---

Plug the power adapter into the socket of the cable modem and two-pin plug in the AC outlet to power on the modem.

---

**Note: Only use the power adapter that comes with the modem. Using another power adapter can cause damage to the product, and will void the warranty.**

---

Connect an Ethernet cable (direct connection, see below) to the Ethernet port at the back of the computer, and the other end to the ETHERNET port on the rear panel of the cable modem. The modem will seek the appropriate cable signal on the cable television network and go through the initial registration process on its own. The modem is ready for data transfer after the green LED "ONLINE" is lit continuously.

---

**Note: the button "RESET" at the back of the modem is used primarily for maintenance.**

---

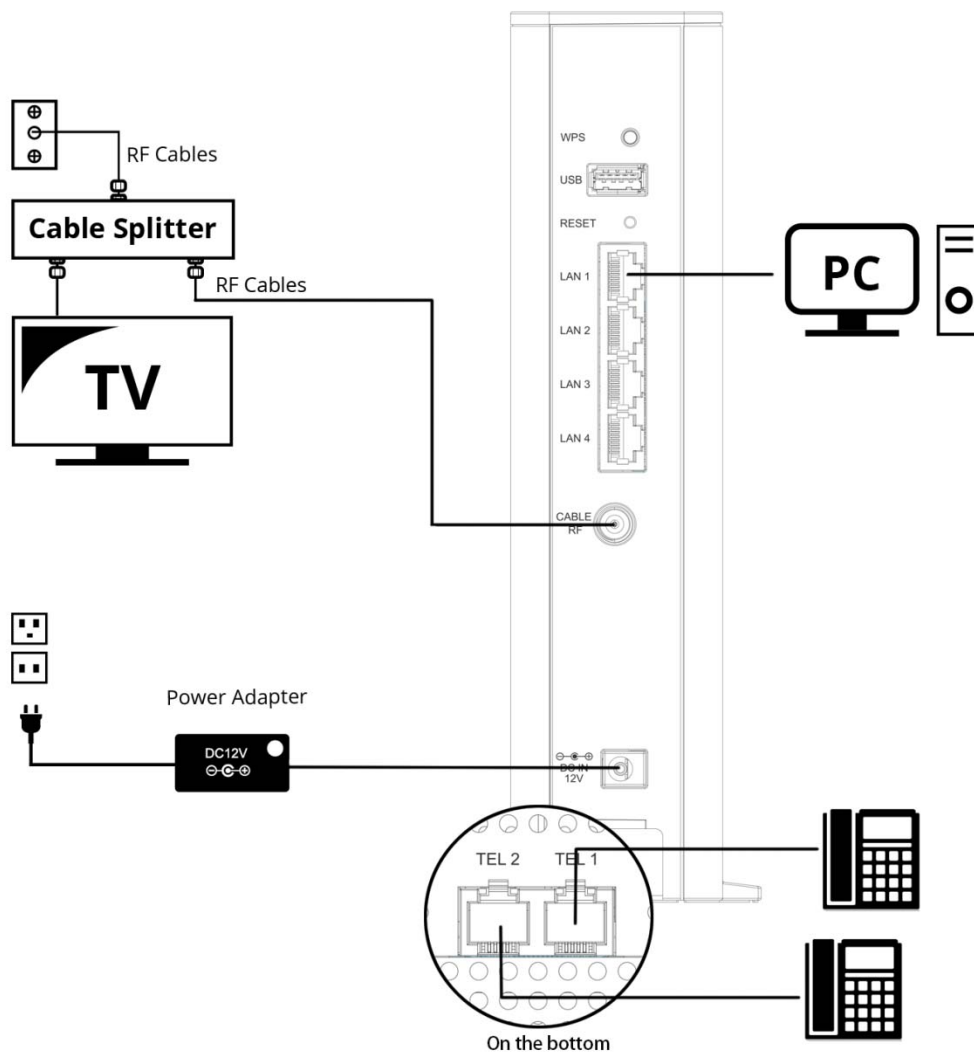

Fig. 1-7 Connect to the Modem

## Telephone or Fax Connection

When properly connected, most telephony devices can be used with the Wireless Voice Gateway just as with a conventional telephone service. To make a normal telephone call, pick up the handset; listen for a dial tone, then dial the desired number. For services such as call waiting, use the hook switch (or FLASH button) to change calls. The following procedures describe some of the possible connection schemes for using telephony devices with the Wireless Voice Gateway.

1. Connect a standard phone line cord directly from the phone (fax machine, answering machine, caller ID box, etc.) to one of the TEL jacks on the Wireless Voice Gateway.
2. If there is a phone line in your home which is NOT connected to another telephone service provider, connect a standard phone line cord from a jack on this line to one of the TEL jacks of the Wireless Voice Gateway. Connect a standard phone line cord directly from the phone (fax machine, answering machine, caller ID box, etc.) to one of the other jacks in the house that uses that line.
3. If you have a multi-line telephone, connect a standard phone line cord (not an RJ-14 type line cord) from the phone to the TEL jacks on the Wireless Voice Gateway. (Other phones can be added to each line by using standard phone line splitters.)

## CHAPTER 2: WEB CONFIGURATION

To make sure that you can access the Internet successfully, please check the following first.

1. Make sure the connection (through Ethernet) between the Wireless Voice Gateway and your computer is OK.
2. Make sure the TCP/IP protocol is set properly.
3. Subscribe to a Cable Company.

### Accessing the Web Configuration (For basic account only)

The **Wireless Voice Gateway** offers local management capability through a built-in HTTP server and a number of diagnostic and configuration web pages. You can configure the settings on the web page and apply them to the device.

Once your host PC is properly configured; please proceed as follows:

1. Start your web browser and type the private IP address of the Wireless Voice Gateway on the URL field: **192.168.100.1**
2. After connecting to the device, you will be prompted to enter username and password. By default, the username is "**user**" and password is "**user**".

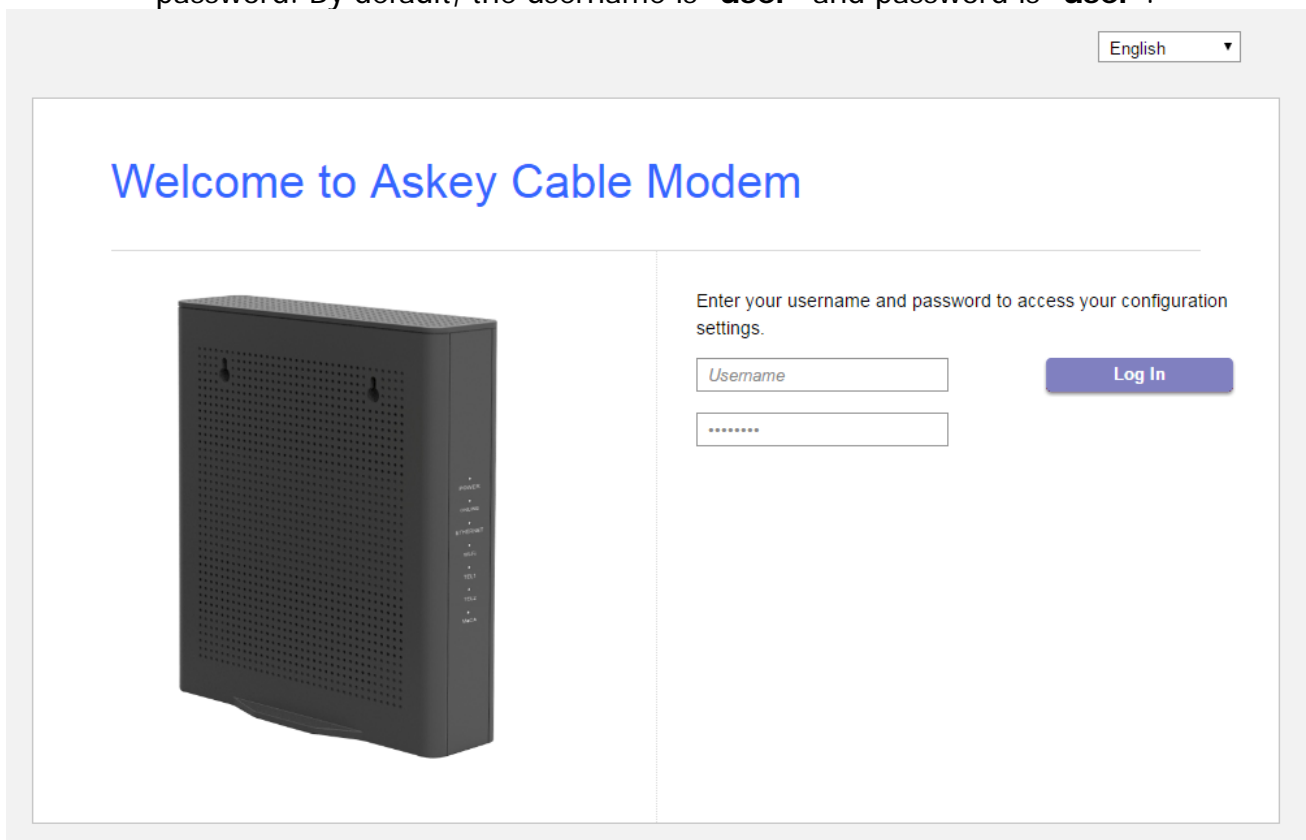

Fig2-1 Login dialogue

**Note: If forget your username and password, you may Press "Reset" button on the rear panel more than 5seconds to restore the username and password to default.**

If you login successfully, the main page will appear. "

You can change the display language to "English", "Suomi", "中文", " Deutsche", "Nederlands", "Français" or "日本語" on the top of the page.

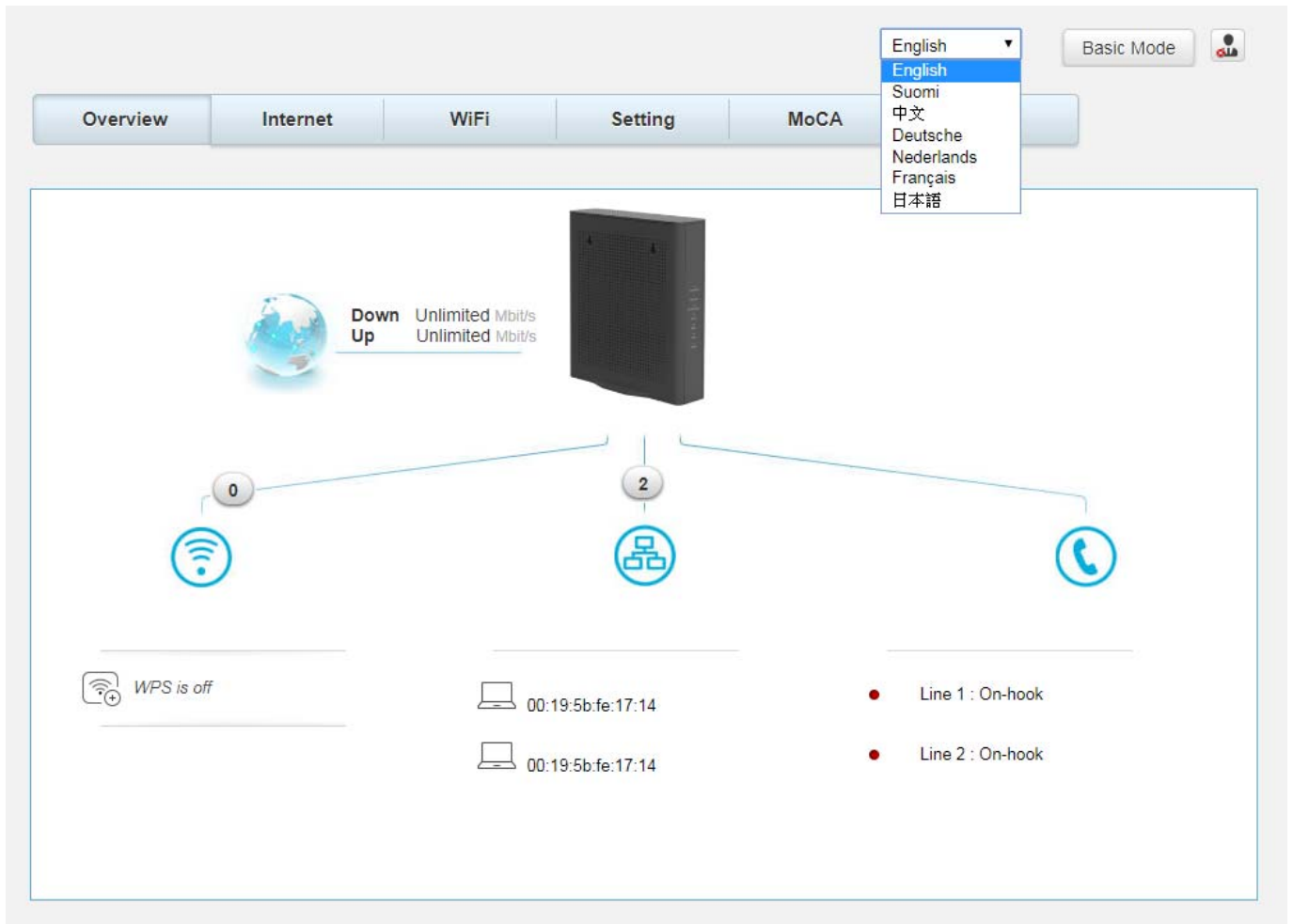





Fig. 2-2 Switch Language

## Overview Web Page Group

### Overview

The Overview page is the start page. You could switch to other pages. (e.g., Internet, Wi-Fi, Setting, MoCA, Status)

This page display Wi-Fi, ETHERNET and VoIP connection status. You could click the icons  ,  and  will lead to Wi-Fi, LAN and VoIP status pages.

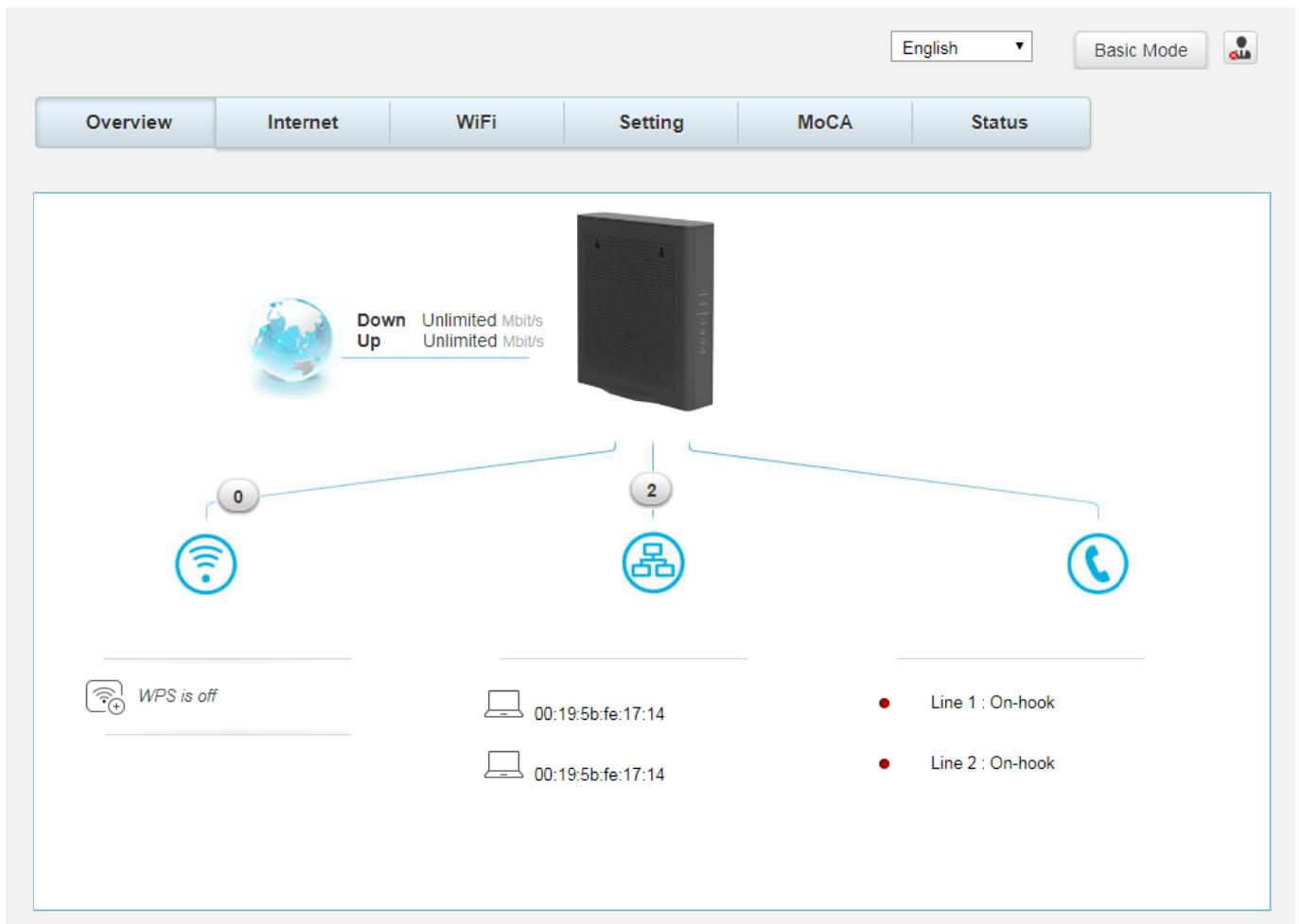

Fig.2-3 Overview

# Internet Web Page Group

## Parental Control

This page allows you to set the time limit for a client's network usage.

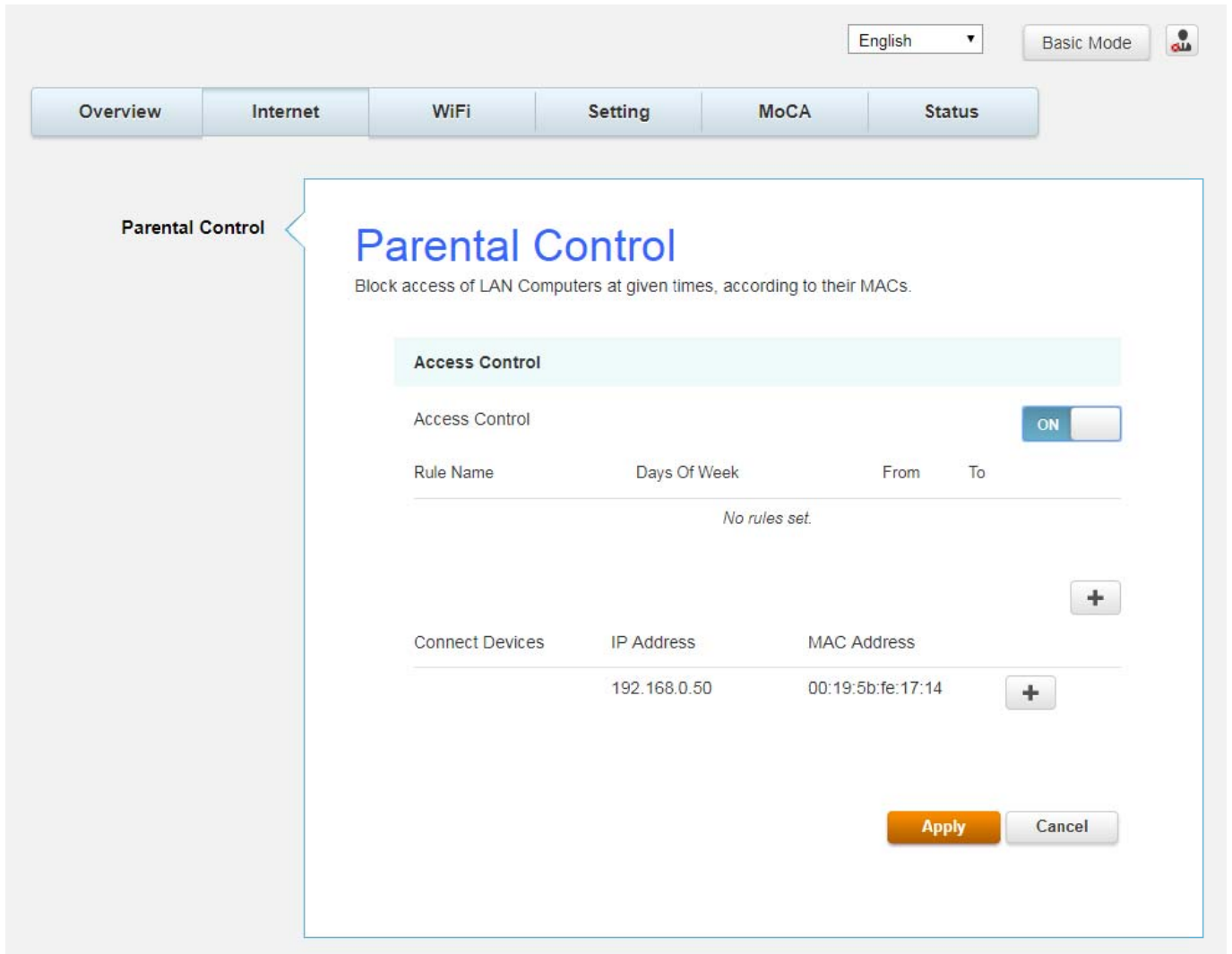

Fig.2-4 Internet\Parental Control

## Wi-Fi Web Page Group

### General

This page allows configuration of the 2.4GHz and 5GHz wireless features. These must match the settings you make on your wireless-equipped PC on the LAN side.

The screenshot shows the 'General' configuration page for Wi-Fi. At the top, there are tabs for 'Overview', 'Internet', 'WiFi', 'Setting', 'MoCA', and 'Status'. The 'WiFi' tab is selected. On the left, a sidebar lists 'General', 'Guest Network', 'WPS', 'WiFi Clients', 'WiFi Radar', and 'Reset'. The main content area is titled 'General' and includes a descriptive paragraph: 'Your router supports the industry-wide WLAN standards with transmission rates up to 300 Mbit/s (802.11b/g/n), enabling easy wireless connection of your devices.'

**2.4G Setup**

- 2.4G WiFi Network:  ON
- Current Channel: 1
- Current Bandwidth: 40 MHz
- Current Sideband: Lower

**WiFi**

- WiFi Name (SSID): ASKEY\_B2BC
- Interface Type: 802.11 b/g/n
- Sideband(40MHz only): Lower
- Channel: 1
- Bandwidth: 20/40 MHz
- Output Power: 100%
- Broadcast SSID:  ON
- WiFi Protection: WPA+WPA2/TKIP+AES
- Network Key: [Redacted]
- Display Characters:
- Change Key: [Button]

**5G Setup**

- 5G WiFi Network:  ON
- Current Channel: 36
- Current Bandwidth: 80 MHz

**WiFi**

- WiFi Name (SSID): ASKEY\_B2BC
- Interface Type: 802.11 a/n/ac
- Sideband(40MHz only): Lower
- Channel: 36
- Bandwidth: 20/40/80 MHz
- Output Power: 100%
- Broadcast SSID:  ON
- WiFi Protection: WPA+WPA2/TKIP+AES
- Network Key: [Redacted]
- Display Characters:
- Change Key: [Button]

At the bottom, there are 'Apply' and 'Cancel' buttons.

Fig.2-5 Wi-Fi\General



- **2.4GWi-Fi Network / 5GWi-Fi Network:** It may help you to **Enable** or **Disable** the 2.4GHz / 5GHz wireless function.
- **Current Channel:** The channel that you choose will be displayed in this field.
- **Current Bandwidth:** The bandwidth that you choose will be displayed in this field.
- **Current Sideband:** The sideband that you choose will be displayed in this field.
- **Wi-Fi Name (SSID):** The SSID for 2.4GHz / 5GHz wireless function.
- **Interface Type:** There are three different modes can be selected. 2.4GHz can be selected 802.11b/g, 802.11b/g/n and 802.11n only; 5GHz can be selected 802.11a, 802.11a/n/ac and 802.11n/ac only.
- **Sideband (40MHz only):** There is "Lower" and "Upper" can be selected if Bandwidth 40 MHz was enabled.

- **Channel:**

***Channels for US***

2.4GHz:

802.11b,802.11g,802.11n(HT20):11

802.11n(HT40):7

5 GHz:

802.11a,802.11n(HT20),802.11ac(VHT20):25

802.11n(HT40),802.11ac(VHT40) :12

802.11 ac(VHT80) :6

***Channels for Canada***

2.4GHz:

802.11b,802.11g,802.11n(HT20):11

802.11n(HT40):7

5 GHz:

802.11a,802.11n(HT20),802.11ac(VHT20):22

802.11n(HT40),802.11ac(VHT40) :10

802.11 ac(VHT80) :5

Choose the one that is suitable for this device.

- **Bandwidth:** Select wireless channel width **20/40 MHz** is for 2.4GHz Wi-Fi default value, and **20/40/80 MHz** is for 5GHz Wi-Fi default value. (Bandwidth taken by wireless signals of this access point.)
- **Output Power:** This setting decides the output power of this device. You may use it to economize on electricity by selecting lower percentage of power output. Control the range of the AP by adjusting the radio output power.

- **Broadcast SSID:** Broadcasting the SSID causes the name of your network to appear in the list of available networks.
- **Wi-Fi Protection:** The method of Wi-Fi protection can be OFF, WPA, WPA2/AES or WPA+WPA2/TKIP+AES.
- **Network key:** The network key is the password that you use to authenticate with your router.
- **QR Code:** Use QR code scanning APP on the smartphone to get Wi-Fi Name (SSID), Wi-Fi Protection and Network key.



Fig.2-6 Wi-Fi\General\QR Code



Fig.2-7 Wi-Fi\General\Scanning result

- WIFI: S (SSID): **ASKEY\_B2BC**
- T (Wi-Fi Protection): **WPA**
- P (Network key): **zNyQzYwEGNRTN**

For Android users, you can install “Barcode Scanner” app to scan Wi-Fi QR code, and the smart phone will be able to connect automatically without entering the SSID and password.

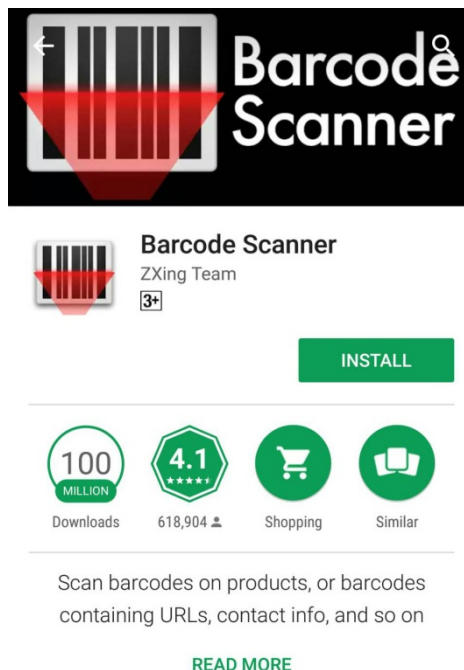

Fig.2-8 Wi-Fi\General\Android APP

## **802.11x Authentication introduction**

If you enable the **802.11x authentication** function, you will have to offer the following information-

- **WPA (Wi-Fi Protected Access)/WPA2:**

It must be used in conjunction with an authentication server such as RADIUS to provide centralized access control and management. It can provide stronger encryption and authentication solution than none WPA modes. **WPA2** is the second generation of **WPA** security.

- **WPA/WPA2 Encryption:**

There are two types that you can choose, **AES, TKIP+AES**.

**TKIP** takes the original master key only as a starting point and derives its encryption keys mathematically from this master key. Then it regularly changes and rotates the encryption keys so that the same encryption key will never be used twice

**AES** provides security between client workstations operating in ad hoc mode. It uses a mathematical ciphering algorithm that employs variable key sizes of 128, 192 or 256 bits.

## Guest Network

This page allows configuration of the 2.4GHz and 5GHz guest network.

English Basic Mode

Overview Internet **WiFi** Setting MoCA Status

General  
**Guest Network**  
WPS  
WiFi Clients  
WiFi Radar  
Reset

### Guest Network

This page allows configuration of a guest network.

#### 2.4G Setup

2.4G WiFi Network

WiFi

WiFi Name (SSID) ASK\_G\_1\_XXXX\_0\_1

Broadcast SSID

WiFi Protection WPA+WPA2/TKIP+AES

Network Key .....

Display Characters

Change Key

#### Guest LAN Settings

IP Address ??.?.?

Subnet Mask 255.255.255.0

Lease Pool Start

Lease Pool End

Lease Time 0

#### 5G Setup

5G WiFi Network

WiFi

WiFi Name (SSID) ASK\_G\_2\_XXXX\_1\_1

Broadcast SSID

WiFi Protection WPA+WPA2/TKIP+AES

Network Key .....

Display Characters

Change Key

#### Guest LAN Settings

IP Address ??.?.?

Subnet Mask 255.255.255.0

Lease Pool Start

Lease Pool End

Lease Time 0

Apply Cancel

Fig.2-9 Wi-Fi\Guest Network

- **2.4G Wi-Fi Network / 5G Wi-Fi Network:** It may help you to **Enable** or **Disable** the 2.4GHz / 5GHz wireless function.
- **Wi-Fi Name (SSID):** The SSID for 2.4GHz / 5GHz Guest wireless function.
- **Broadcast SSID:** Broadcasting the SSID causes the name of your network to appear in the list of available networks.
- **Wi-Fi Protection:** The method of Wi-Fi protection can be OFF, WPA, WPA2/AES or WPA+WPA2/TKIP+AES.
- **Network key:** The network key is the password that you use to authenticate with your router.
- **QR Code:** Use QR code scanning APP on the smartphone to get Wi-Fi Name (SSID), Wi-Fi Protection and Network key.



Fig.2-10 Wi-Fi\General\QR Code

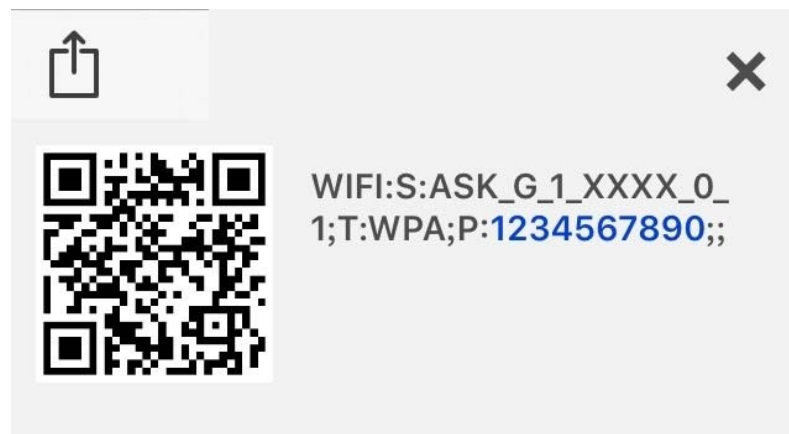

Fig.2-11 Wi-Fi\General\Scanning result

- WIFI: S (SSID): **ASK\_G\_1\_XXXX\_0\_1**
- T (Wi-Fi Protection): **WPA**
- P (Network key): **1234567890**

For Android users, you can install “Barcode Scanner” app to scan Wi-Fi QR code, and the smart phone will be able to connect automatically without entering the SSID and password.

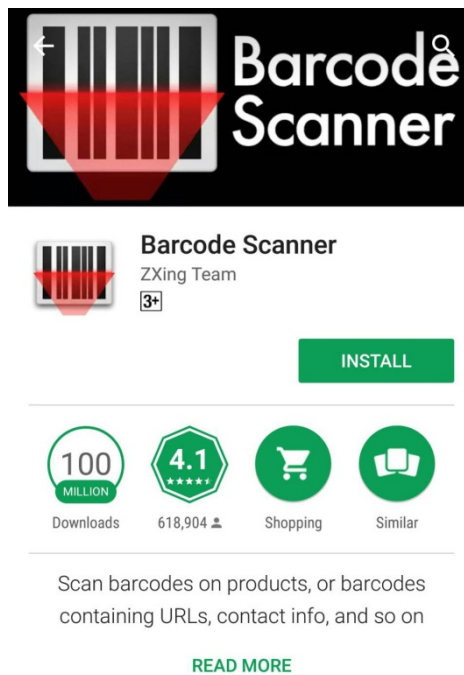

Fig.2-12 Wi-Fi\General\Android APP

## Guest LAN Settings

A private IP address and Subnet Mask for LAN sub netting.

For example 192.168.0.1 / 255.255.255.0.

- Configure the IP address numbers for the DHCP server with “**Lease pool start**” and “**Lease pool end**”.
- Configure the IP address lease time with “**Lease time**” for DHCP server.

## **802.11x Authentication introduction**

If you enable the **802.11x authentication** function, you will have to offer the following information-

- **WPA (Wi-Fi Protected Access)/WPA2:**

It must be used in conjunction with an authentication server such as RADIUS to provide centralized access control and management. It can provide stronger encryption and authentication solution than none WPA modes. **WPA2** is the second generation of **WPA** security.

- **WPA/WPA2 Encryption:**

There are two types that you can choose, **AES**, **TKIP+AES**.

**TKIP** takes the original master key only as a starting point and derives its encryption keys mathematically from this mater key. Then it regularly changes and rotates the encryption keys so that the same encryption key will never be used twice

**AES** provides security between client workstations operating in ad hoc mode. It uses a mathematical ciphering algorithm that employs variable key sizes of 128, 192 or 256 bits.



# WPS

This page allows you to configure WPS setting. Wi-Fi Protected Setup™ (WPS) is an easy and secure way of configuring and connecting your Wireless access point. In this case, the Wireless Voice Gateway is the Access Point (AP), and your PC (or Wireless Device) is called the STA. When configuring your Wireless Network via WPS, messages are exchanged between the STA and AP in order to configure the security settings on both devices.

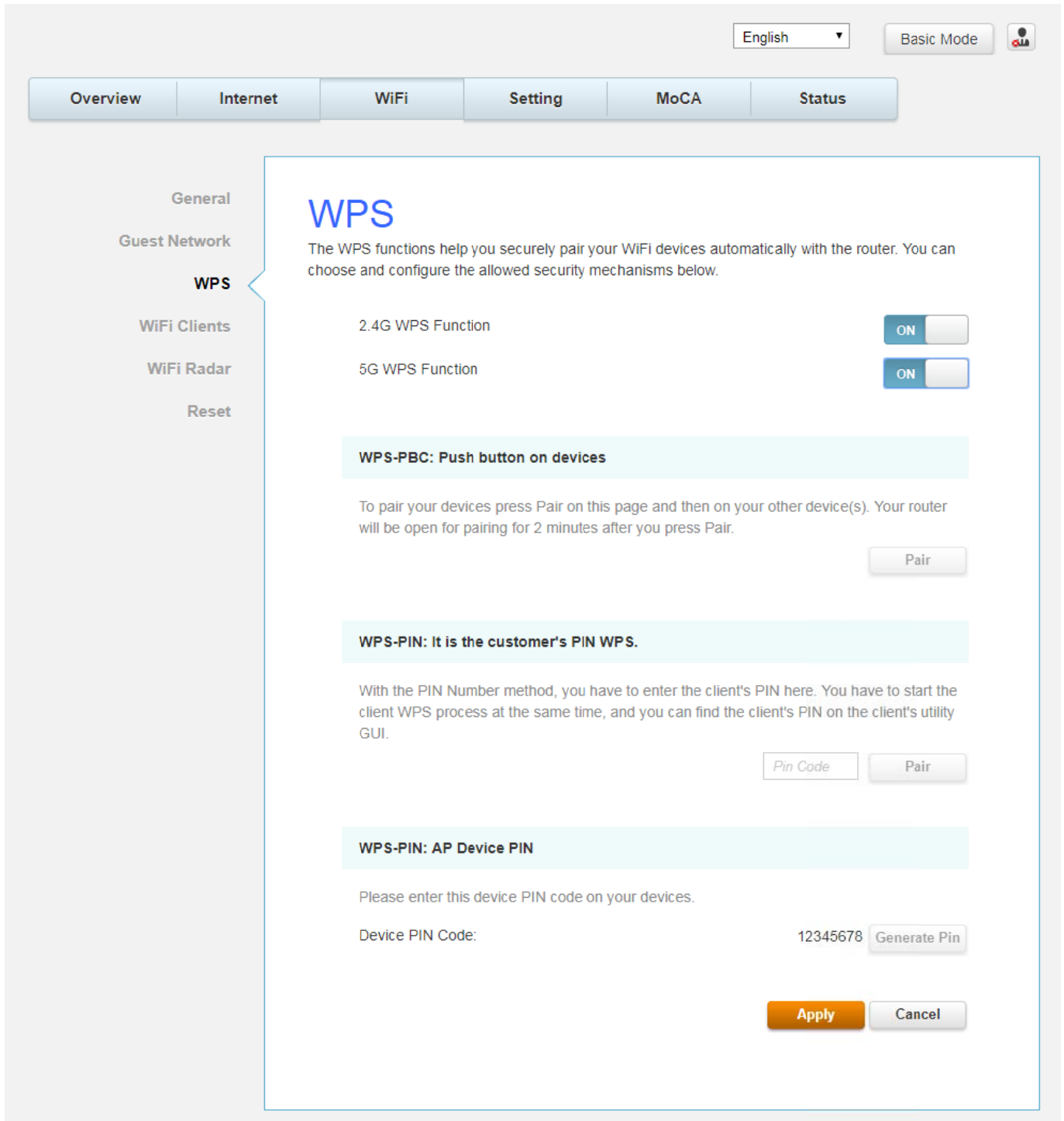

Fig.2-13 Wi-Fi\WPS

## Wi-Fi Clients

This page shows all Wi-Fi clients.

The screenshot shows a network management interface with a top navigation bar containing 'Overview', 'Internet', 'WiFi', 'Setting', 'MoCA', and 'Status'. The 'WiFi' tab is selected. On the right, there are language and mode settings: 'English' (dropdown), 'Basic Mode' (button), and a user profile icon. A left sidebar contains a menu with 'General', 'Guest Network', 'WPS', 'WiFi Clients' (highlighted), 'WiFi Radar', and 'Reset'. The main content area is titled 'WiFi Clients' and includes the text 'This page shows all WiFi clients.' Below this, there are two sections: '2.4G WiFi Clients' and '5G WiFi Clients'. Each section contains a table with columns for Device, IP Address, MAC Address, Type, Signal (dBm), Channel, and Security. Both tables are currently empty, displaying the message 'No WiFi clients connected.'

English ▾ Basic Mode

Overview Internet **WiFi** Setting MoCA Status

General  
Guest Network  
WPS  
**WiFi Clients**  
WiFi Radar  
Reset

### WiFi Clients

This page shows all WiFi clients.

#### 2.4G WiFi Clients

Device	IP Address	MAC Address	Type	Signal (dBm)	Channel	Security
No WiFi clients connected.						

#### 5G WiFi Clients

Device	IP Address	MAC Address	Type	Signal (dBm)	Channel	Security
No WiFi clients connected.						

Fig.2-14 Wi-Fi\Wi-Fi Clients

## Wi-Fi Radar

The Wi-Fi Radar can display the wireless networks, See the wireless networks around you.

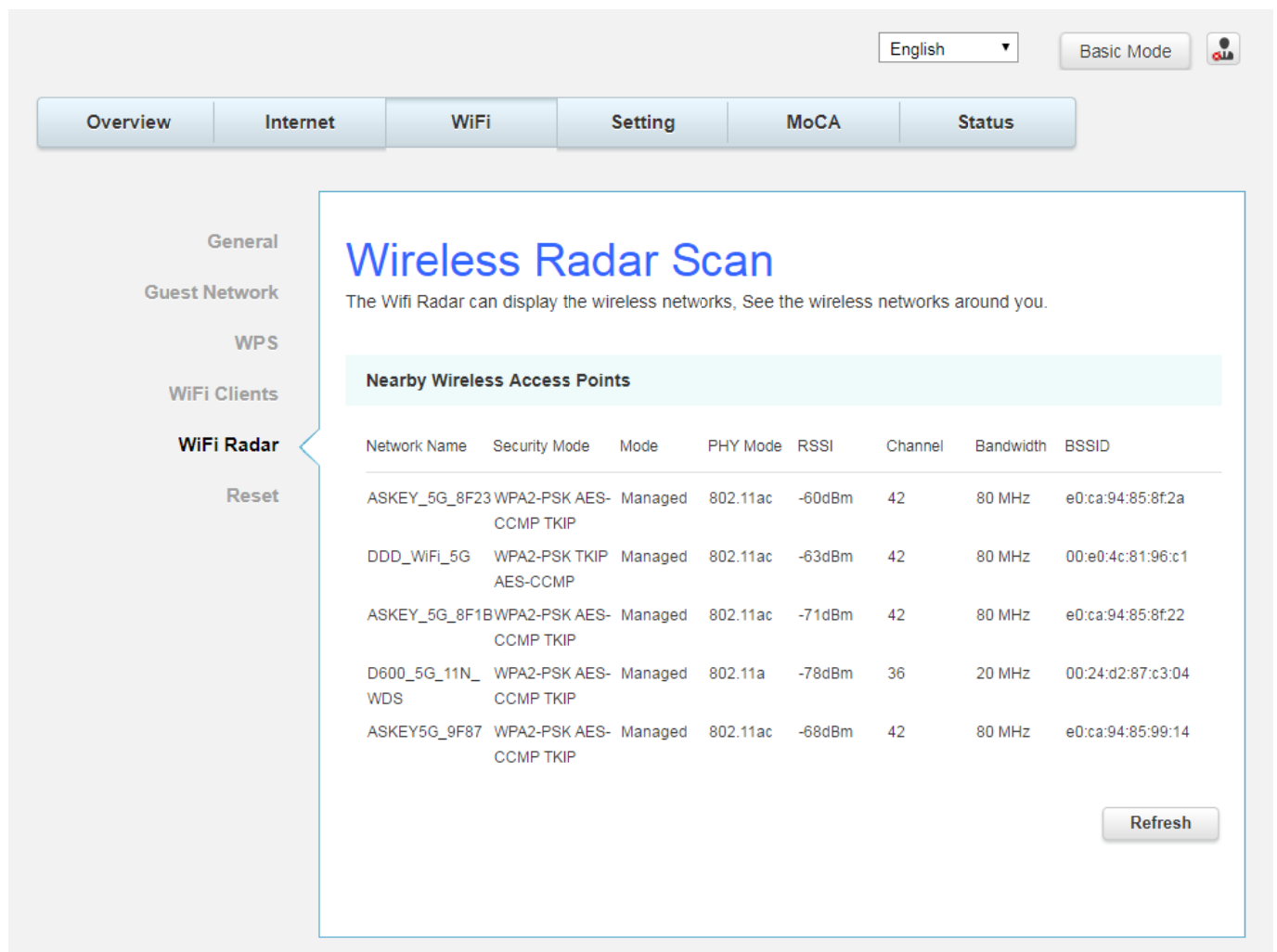

The screenshot shows the 'WiFi Radar' section of a network management interface. At the top, there are navigation tabs: Overview, Internet, WiFi (selected), Setting, MoCA, and Status. On the right, there are language and mode settings: English, Basic Mode, and a user icon. A left sidebar contains menu items: General, Guest Network, WPS, WiFi Clients, WiFi Radar (highlighted), and Reset. The main content area is titled 'Wireless Radar Scan' and includes a description: 'The Wifi Radar can display the wireless networks, See the wireless networks around you.' Below this is a table titled 'Nearby Wireless Access Points' with the following data:

Network Name	Security Mode	Mode	PHY Mode	RSSI	Channel	Bandwidth	BSSID
ASKEY_5G_8F23	WPA2-PSK AES-CCMP TKIP	Managed	802.11ac	-60dBm	42	80 MHz	e0:ca:94:85:8f:2a
DDD_WIFI_5G	WPA2-PSK TKIP AES-CCMP	Managed	802.11ac	-63dBm	42	80 MHz	00:e0:4c:81:96:c1
ASKEY_5G_8F1B	WPA2-PSK AES-CCMP TKIP	Managed	802.11ac	-71dBm	42	80 MHz	e0:ca:94:85:8f:22
D600_5G_11N_WDS	WPA2-PSK AES-CCMP TKIP	Managed	802.11a	-78dBm	36	20 MHz	00:24:d2:87:c3:04
ASKEY5G_9F87	WPA2-PSK AES-CCMP TKIP	Managed	802.11ac	-68dBm	42	80 MHz	e0:ca:94:85:99:14

A 'Refresh' button is located at the bottom right of the table area.

Fig.2-15 Wi-Fi\Wi-Fi Radar

## Reset

This page allows configuration of the wireless network to default.

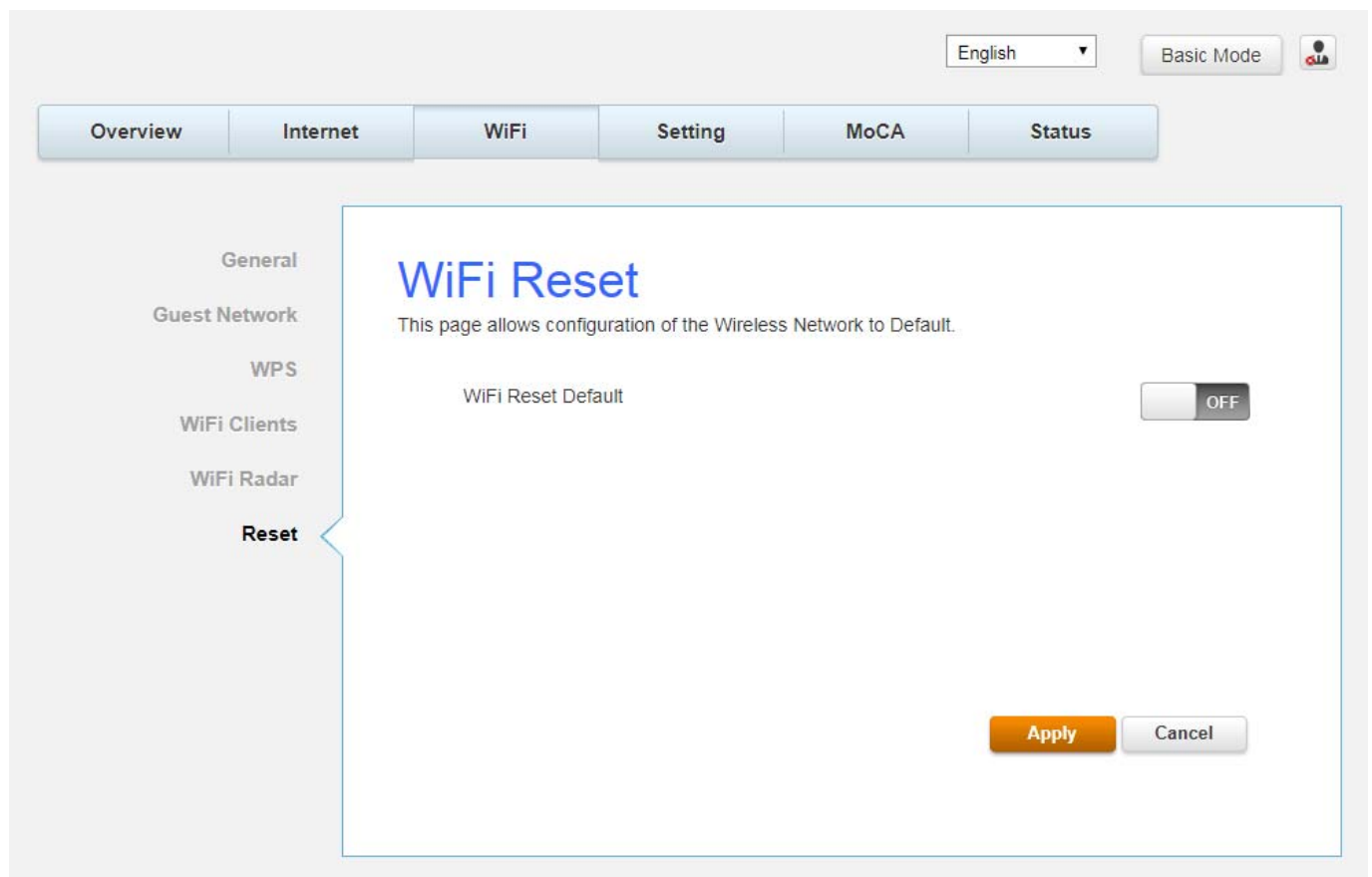

Fig.2-16 Wi-Fi\Reset

## Settings Web Page Group

### Language

This page allows configuration of language.

You can change the display language to “English”, “Suomi”, “中文”, “Deutsche”, “Nederlands”, “Français” or “日本語” on the top of the page.

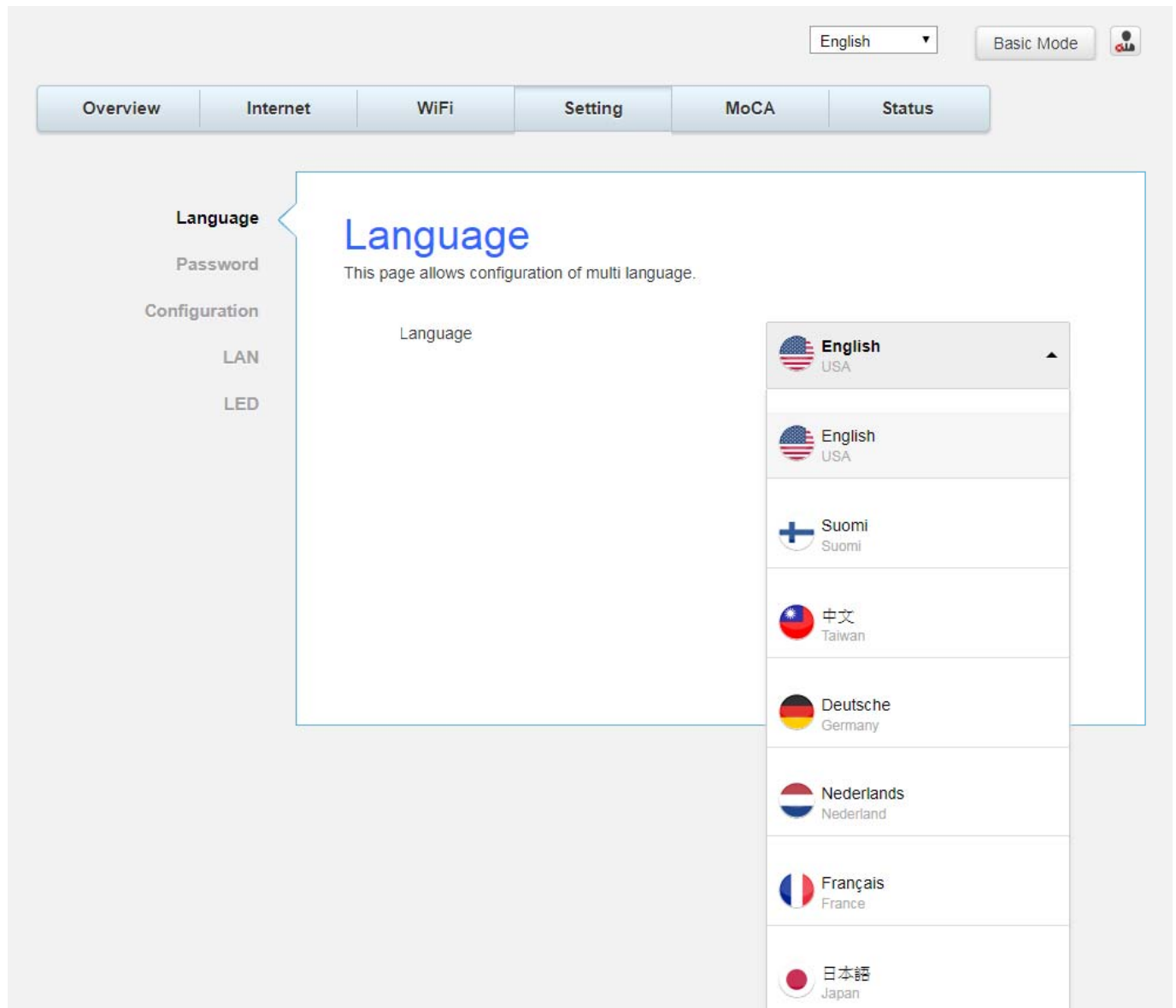

Fig.2-17 Setting\Language

## Password

By default, the username is "user" and password is "user".

When the current password is the default one, the user is strongly encouraged to change the default web password.

The password can be a minimum of 8 characters, maximum of 20 characters and is case sensitive. If forget your username and password, you may Press "Reset" button on the rear panel more than 5seconds to restore the username and password to default.

Note: We are always suggesting you to modify the password. This is a basic protection against wrongful access to the Gateway Web pages.

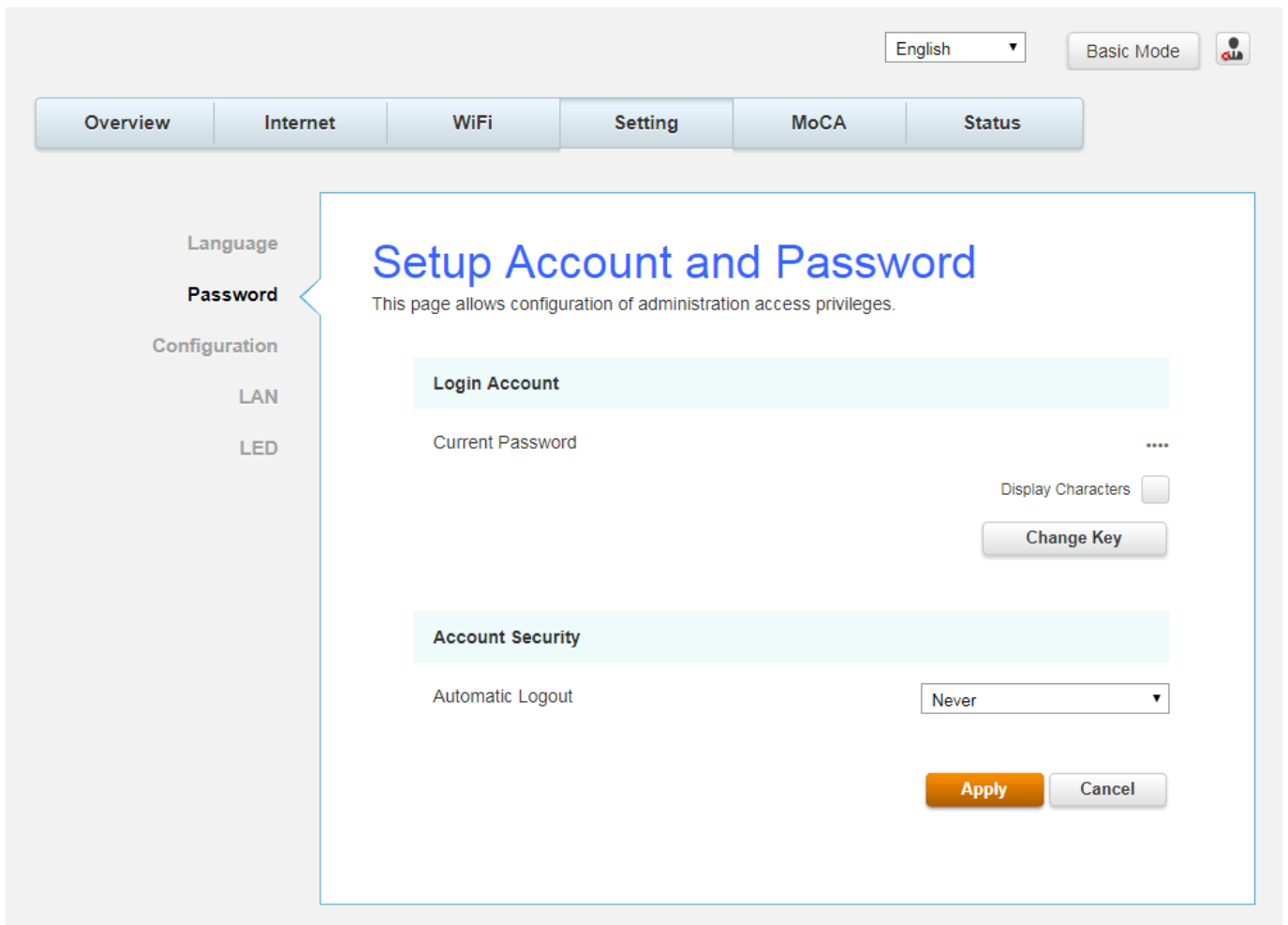

Fig.2-18 Setting\Password

## Configuration

This page allows you to save your current settings locally on your PC, or restore settings previously saved.

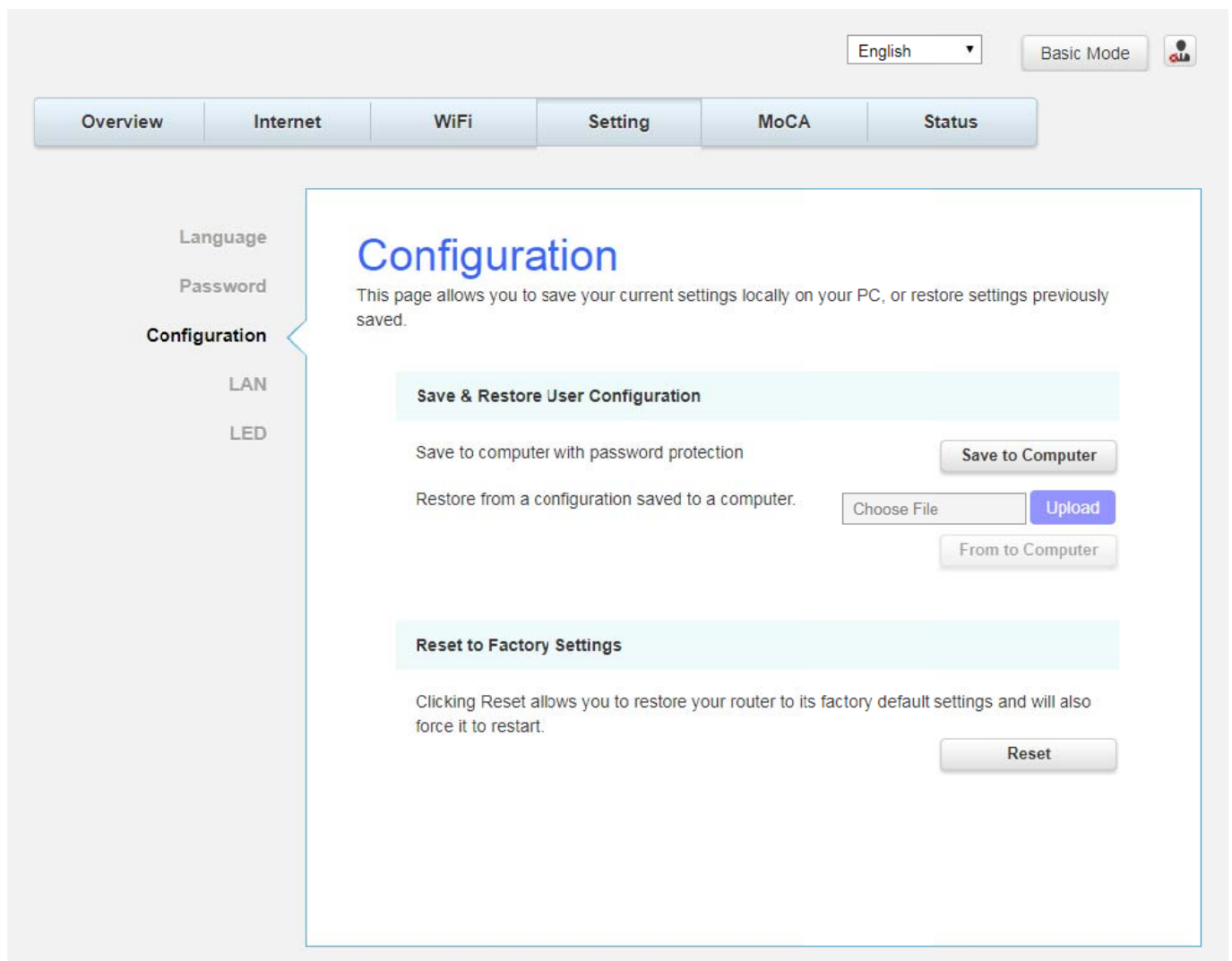

Fig.2-19 Setting\Configuration

- **Save & Restore User Configuration:** To back up the current configuration, click **Save to Computer** and follow the prompts.

To restore a previous configuration, click **Upload** and use the navigation window to locate the file (usually backupsettings.conf.) Once the file has been located, click **From to Computer** to restore the settings. Once the settings are restored, the device will reboot.

- **Reset to Factory Settings:** Click **Reset** allows you to restore your router to factory default settings and will also force it to restart.

# LAN

This page allows configuration of the basic features of the broadband gateway related to your ISP's connection.

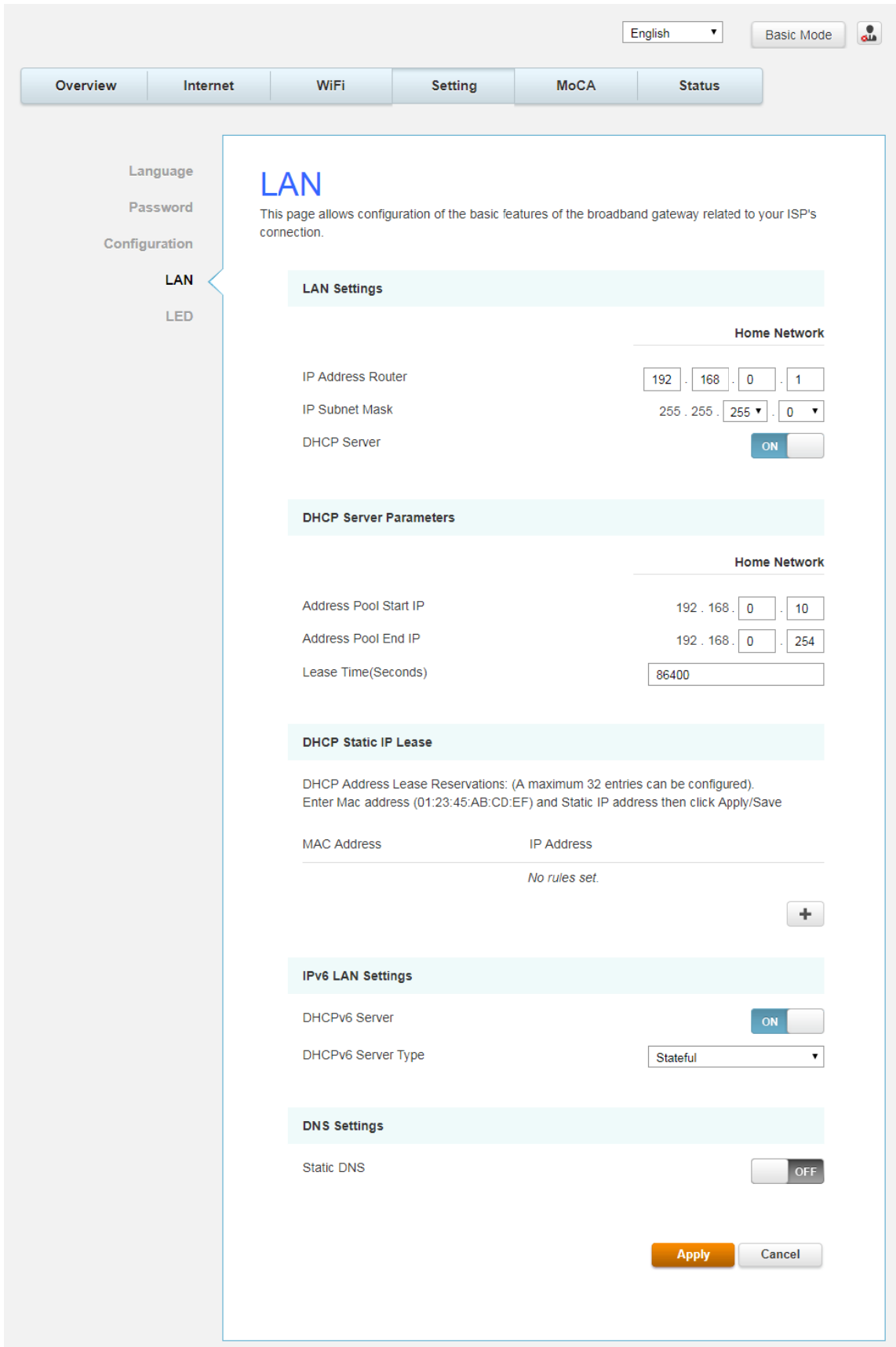

Fig.2-20 Setting\LAN



## LED

This page allows configuration of the LED brightness.

The screenshot shows a web interface for configuring LED brightness. At the top right, there is a language dropdown set to 'English', a 'Basic Mode' button, and a user profile icon. Below this is a navigation bar with tabs for 'Overview', 'Internet', 'WiFi', 'Setting', 'MoCA', and 'Status'. On the left side, a sidebar menu lists 'Language', 'Password', 'Configuration', 'LAN', and 'LED', with 'LED' highlighted. The main content area is titled 'LED Brightness' and contains the following settings:

- LED Brightness:** A toggle switch set to 'ON'.
- Brightness Level:** A horizontal slider control.
- Time Option:** A toggle switch set to 'ON'.
- From:** A time input field containing '00:00'.
- To:** A time input field containing '00:00'.
- Brightness Level:** A second horizontal slider control.

At the bottom right of the configuration area, there are two buttons: 'Apply' (orange) and 'Cancel' (grey).

Fig.2-21 Setting\LED

## MoCA Web Page Group

### MoCA

You will be able to change your MoCA setting here. MoCA is a new technology which utilizes your existing CATV coax at home to form a home networking which will provide high speed home network access.

The screenshot shows the MoCA Configuration page in a web interface. At the top right, there is a language dropdown set to 'English', a 'Basic Mode' button, and a user profile icon. Below this is a navigation bar with tabs for 'Overview', 'Internet', 'WiFi', 'Setting', 'MoCA', and 'Status'. The 'MoCA' tab is selected. The main content area is titled 'MoCA Configuration' and includes a sub-header 'This page Configures the MoCA interface parameters.' Below this, several parameters are listed:

Version	2.12.0.3
Link status	Disconnect
MAC Address	00:10:18:33:90:A0
Privacy	<input checked="" type="checkbox"/> ON
Privacy Password	<input type="password" value="....."/>

Below the password field is a 'Display Characters' checkbox, which is currently unchecked. At the bottom right of the configuration area are two buttons: 'Apply' (highlighted in orange) and 'Cancel'.

Fig.2-22 MoCA\MoCA

## Status Web Page Group

### Status

This page can find an overview of all your router parameters. This may help you in optimizing or trouble shooting your router.

The screenshot shows the 'Status' page of a router's web interface. At the top, there is a language dropdown set to 'English', a 'Basic Mode' button, and a user profile icon. Below this is a navigation bar with tabs for 'Overview', 'Internet', 'WiFi', 'Setting', 'MoCA', and 'Status'. The 'Status' tab is selected. On the left side, there is a sidebar with links for 'Status', 'Voice Status', 'Up/Down Stream', and 'Event Log'. The main content area has a heading 'Status' and a sub-heading 'System'. Below this, there is a table of system parameters.

System	
Serial Number	A276G008154
Model Vendor	Askey
Model Name	TCG310J
Model Type	Wifi EMTA
CM MAC Address	00:90:00:11:11:03
Firmware version	D263.UUN35.E21.170701.01
Bootloader Version	2.7.0alpha4
Bolt Version	PKE2048JM_D263_Rev04_256Mx2 (v1.17_B1)
Hardware Type & Version	1.0
Uptime since last reboot	0D 1H 8M 6S
Reboot Cause	cm_reset
CPU Usage	12.6 %
Memory Usage	25.5111 %
Wireless Driver Version	10.10.122.303
Date & Time	2017-07-21T11:14:21+08:00

Fig.2-23 Status\Status

## Voice Status

This page displays the initialization status of the MTA containing Telephony DHCP, Security, TFTP and Provisioning Status. The information can be useful to your cable company's support technician if you're having problems.

The screenshot shows a web interface for network management. At the top right, there is a language dropdown set to 'English', a 'Basic Mode' button, and a user profile icon. A horizontal navigation bar contains tabs for 'Overview', 'Internet', 'WiFi', 'Setting', 'MoCA', and 'Status'. The 'Status' tab is selected. On the left side, a vertical menu lists 'Status', 'Voice Status' (highlighted), 'Up/Down Stream', and 'Event Log'. The main content area is titled 'Voice Status' and includes a sub-header 'Provision Status' with a table of task statuses. Below that is another sub-header 'MTA Line State' with a table showing the status of two telephony lines.

Task	Status
Telephony DHCP	Completed
Telephony Security	Disabled
Telephony TFTP	Completed
Telephony Prov Result	Pass
Telephony Prov Method	BASIC.1
Telephony Prov MTA IP	"10.10.144.57 / 255.255.255.0"
Telephony Prov CMS FQDN	L1: "lilian.qostek.com" L2: "lilian.qostek.com"

Lines	Telephony Call Server Registration	Hook State
Line 1	● Disconnected	On-hook
Line 2	● Disconnected	On-hook

Fig.2-24 Status\Voice Status

## Up/Down Stream

This page reports current CM's upstream / downstream information. The information can be useful to your cable company's support technician if you're having problems.

By entering downstream frequency in KHz and clicking "Force frequency" button, you can force the CM locking to the specified frequency.

The screenshot shows a web interface for a cable modem. At the top, there is a language dropdown set to 'English', a 'Basic Mode' button, and a user icon. Below this is a navigation bar with tabs for 'Overview', 'Internet', 'WiFi', 'Setting', 'MoCA', and 'Status'. The 'Status' tab is selected. On the left side, there is a sidebar with links for 'Status', 'Voice Status', 'Up/Down Stream', and 'Event Log'. The main content area is titled 'Up/Down Stream' and contains an explanatory paragraph: 'Upstream or upload speed is the term given to the data that your computer sends out to the Internet. Downstream or download speed is the term given to the data that your computer receives from the Internet. Cable modems have what is known as asymmetrical speeds because upstream and downstream capabilities are different.'

Below the text are two tables. The first table is titled 'Upstream Channel Status' and has columns: Transmitter #, Channel ID, Lock Status, Frequency, Symbol Rate, Channel Type, and Power. It contains two rows of data.

Transmitter #	Channel ID	Lock Status	Frequency	Symbol Rate	Channel Type	Power
1	2	Locked	15608	5120 Ksym/sec	ATDMA	28.3 dBmV
2	1	Locked	9208	5120 Ksym/sec	ATDMA	28.8 dBmV

The second table is titled 'Downstream Channel Status' and has columns: Receiver #, Channel ID, Lock Status, Frequency, Modulation, SNR, and Power. It contains four rows of data.

Receiver #	Channel ID	Lock Status	Frequency	Modulation	SNR	Power
1	1	Locked	603000	QAM256	45.6 dBmV	3.5 dBmV
2	2	Locked	609000	QAM256	45.7 dBmV	3.2 dBmV
3	3	Locked	615000	QAM256	45.5 dBmV	2.8 dBmV
4	4	Locked	621000	QAM256	45.7 dBmV	2.7 dBmV

At the bottom of the page, there is a 'Frequency' label, an input field, the unit 'KHz', and a 'Force Frequency' button.

Fig. 2-25 Status\ Up/Down Stream

## Event log

This page displays the contents of the SNMP event log.

The screenshot shows a web interface for the 'Status' section. At the top right, there is a language dropdown set to 'English', a 'Basic Mode' button, and a user profile icon. Below this is a navigation bar with tabs for 'Overview', 'Internet', 'WiFi', 'Setting', 'MoCA', and 'Status'. The 'Status' tab is active. On the left side, there is a sidebar menu with options: 'Status', 'Voice Status', 'Up/Down Stream', and 'Event Log'. The 'Event Log' option is selected. The main content area is titled 'SNMP Event Log' and contains the text: 'This page display the contents of the SNMP event log.' Below this is a table titled 'Event Log Table' with two columns: 'Time' and 'Description'. The table contains four entries. At the bottom right of the table area, there are two buttons: 'Clear Log' (orange) and 'Refresh' (grey).

Time	Description
Thu Jan 01 00:00:27 1970	SYNC Timing Synchronization failure - Failed to acquire QAM/QPSK symbol timing;
Thu Jan 01 00:00:32 1970	Honoring MDD; IP provisioning mode = IPv4led to acquire QAM/QPSK symbol timing;
Thu Jan 01 00:00:34 1970	DHCP WARNING - Non-critical field invalid in response
Fri Jul 21 11:34:05 2017	TLV-11 - Illegal Set operation failed

Fig. 2-26 Status\Event log

## Accessing the Web Configuration (For admin account only)

Once your host PC is properly configured; please proceed as follows:

1. Start your web browser and type the private IP address of the Wireless Gateway on the URL field: **192.168.100.1**
2. After connecting to the device, you will be prompted to enter username and password. By default, the username is "**admin**" and password is "**admin**".

**This section that introduces the admin account addition pages, and the same as the basic mode pages refer to page 20 ~ 45, please.**

## Internet Web Page Group

### Advanced

This page allows you to configuration of advanced features of the broadband Gateway.

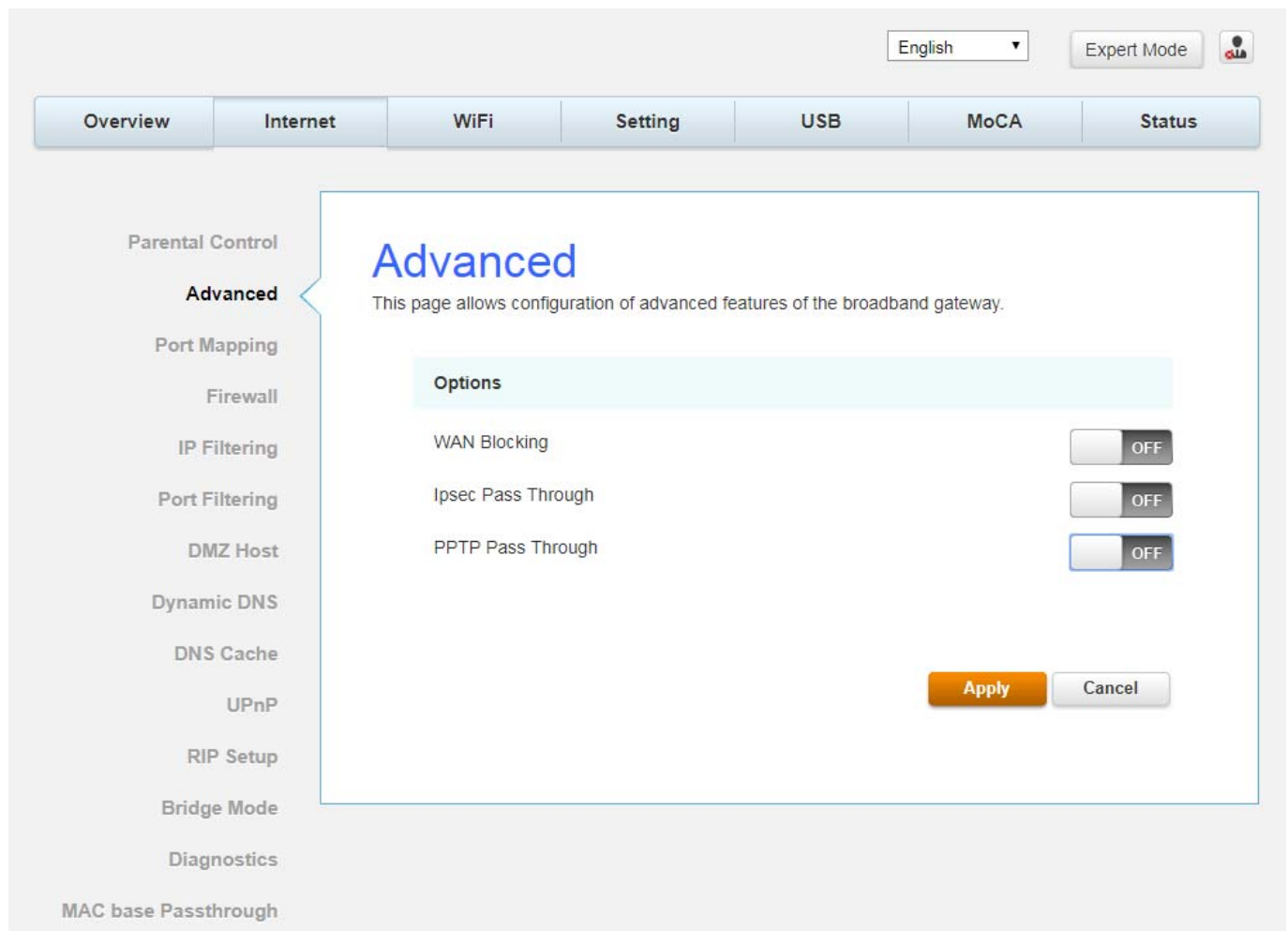

Fig.2-27 Internet\Advanced

- **WAN Blocking** prevents others on the WAN side from being able to ping your gateway. With WAN Blocking enabled, your gateway will not respond to pings it receives, effectively “hiding” your gateway.
- **Ipssec PassThrough** enables IpSec type packets to pass WAN ↔ LAN. IpSec (IP Security) is a security mechanism used in Virtual Private Networks (VPNs).
- **PPTP PassThrough** enables PPTP type packets to pass WAN ↔ LAN. PPTP (Point to Point Tunneling Protocol) is another mechanism sometimes used in VPNs.



## Port Mapping

This page allows configuration of Port Forwarding and Port Triggering.

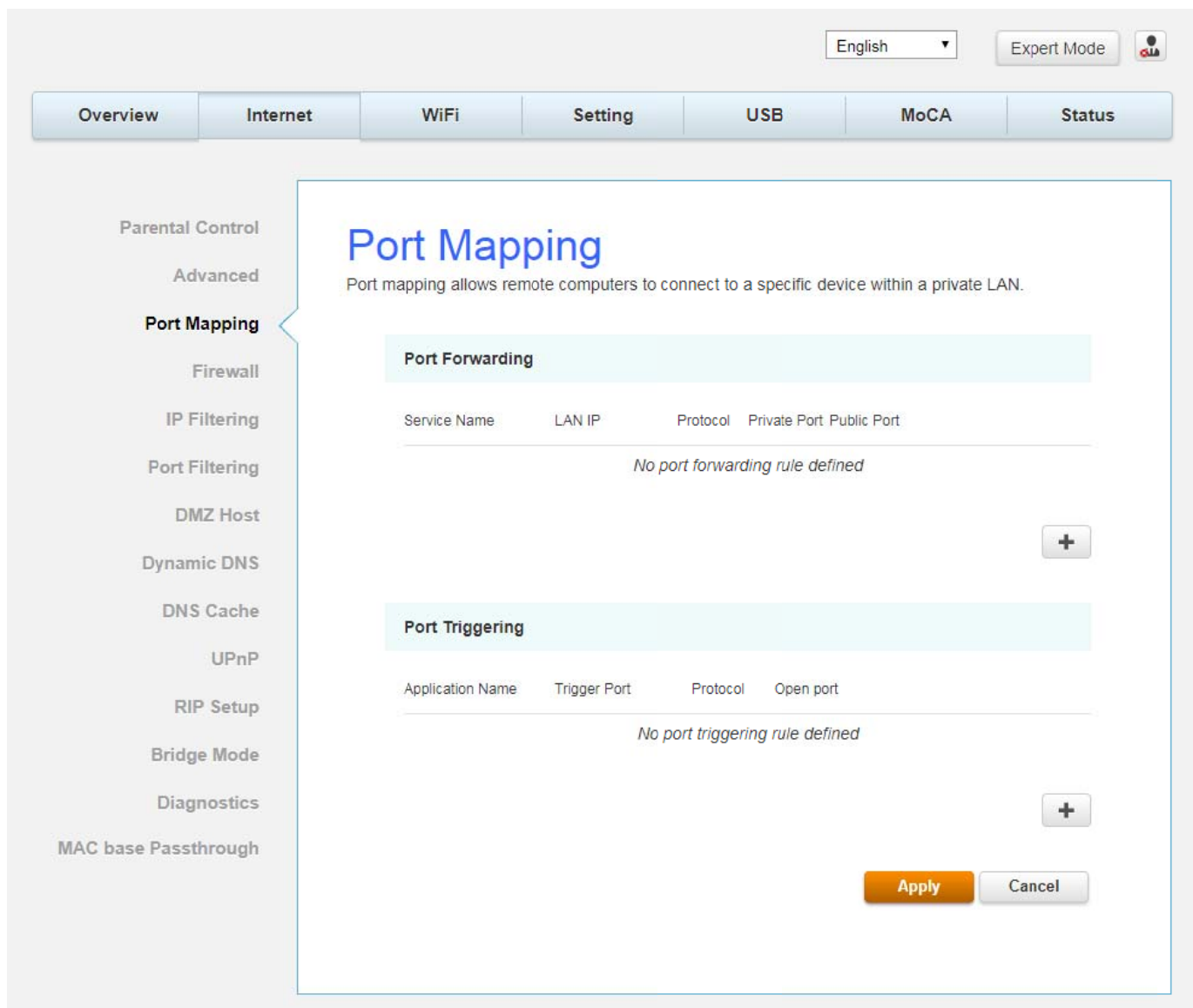

Fig.2-28 Internet\Port Mapping

- **Port Forwarding** For LAN ↔ WAN communications, the gateway normally only allows you to originate an IP connection with a PC on the WAN; it will ignore attempts of the WAN PC to originate a connection onto your PC. This protects you from malicious attacks from outsiders. However, sometimes you may wish for anyone outside to be able to originate a connection to a particular PC on your LAN if the destination port (application) matches one you specify.
- **Port Triggering** Some Internet activities, such as interactive gaming, require that a PC on the WAN side of your gateway be able to originate connections during the game with your game playing PC on the LAN side. Port triggering is an elegant mechanism that does this work for you, each time you play the game.

## Firewall

This page allows you to enable/disable, and you can choose “Off”, “Low”, “Medium”, “High” firewall protection.

The **Low** setting does not block any services/ports, however it does protect against invalid packets and well known attacks. The **Medium** setting will cause the firewall to drop a packet unless it is on a specific port of allowed services. The **High** setting is similar to medium, but allows access to even fewer services. The **Off** setting allows all traffic to pass.

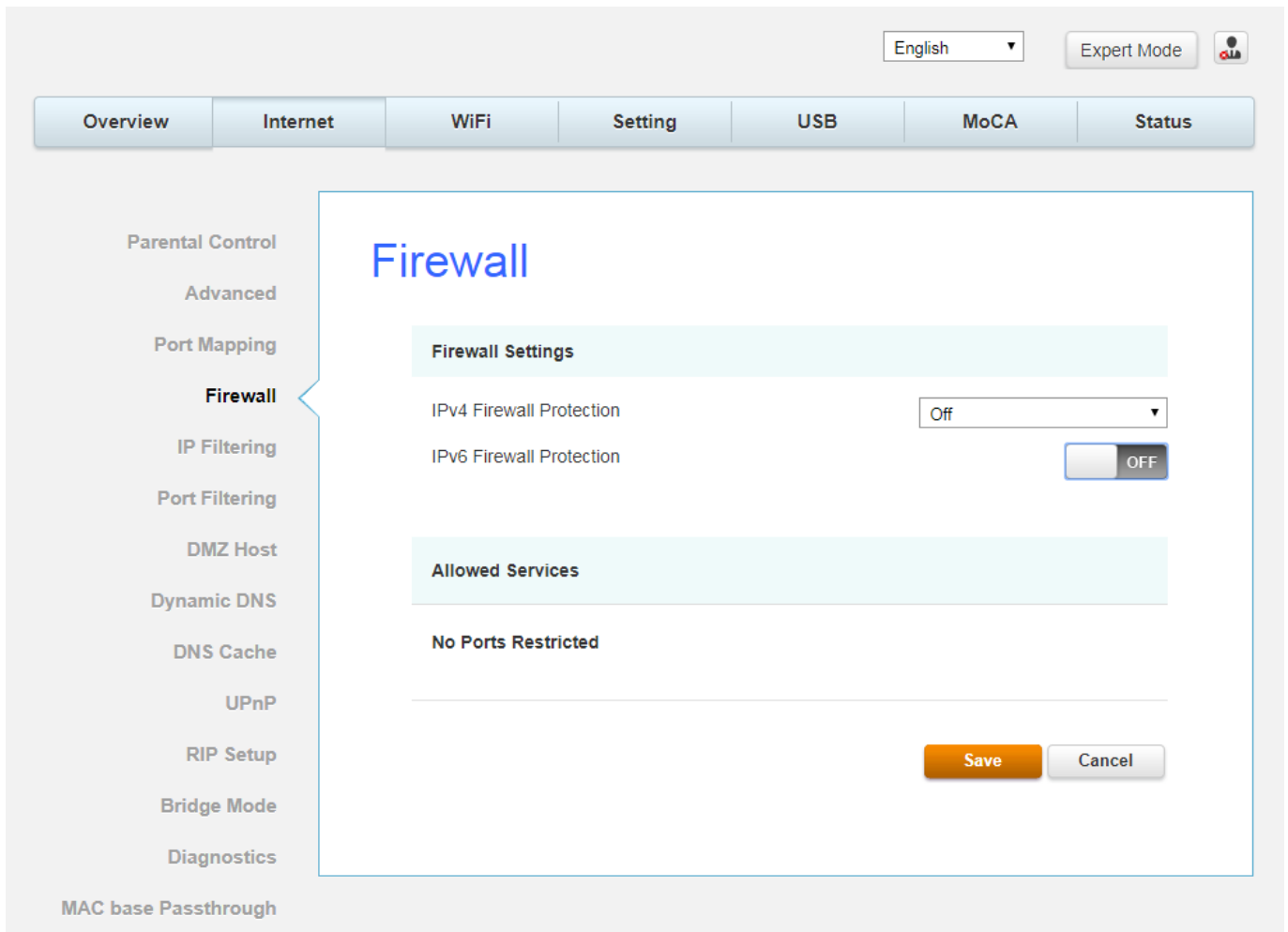

Fig.2-29 Internet\Firewall

## IP Filtering

This page enables you to enter the IP address ranges of PCs on your LAN that you don't want to have outbound access to the WAN. These PCs can still communicate with each other on your LAN, but packets they send to WAN addresses are blocked by the gateway.

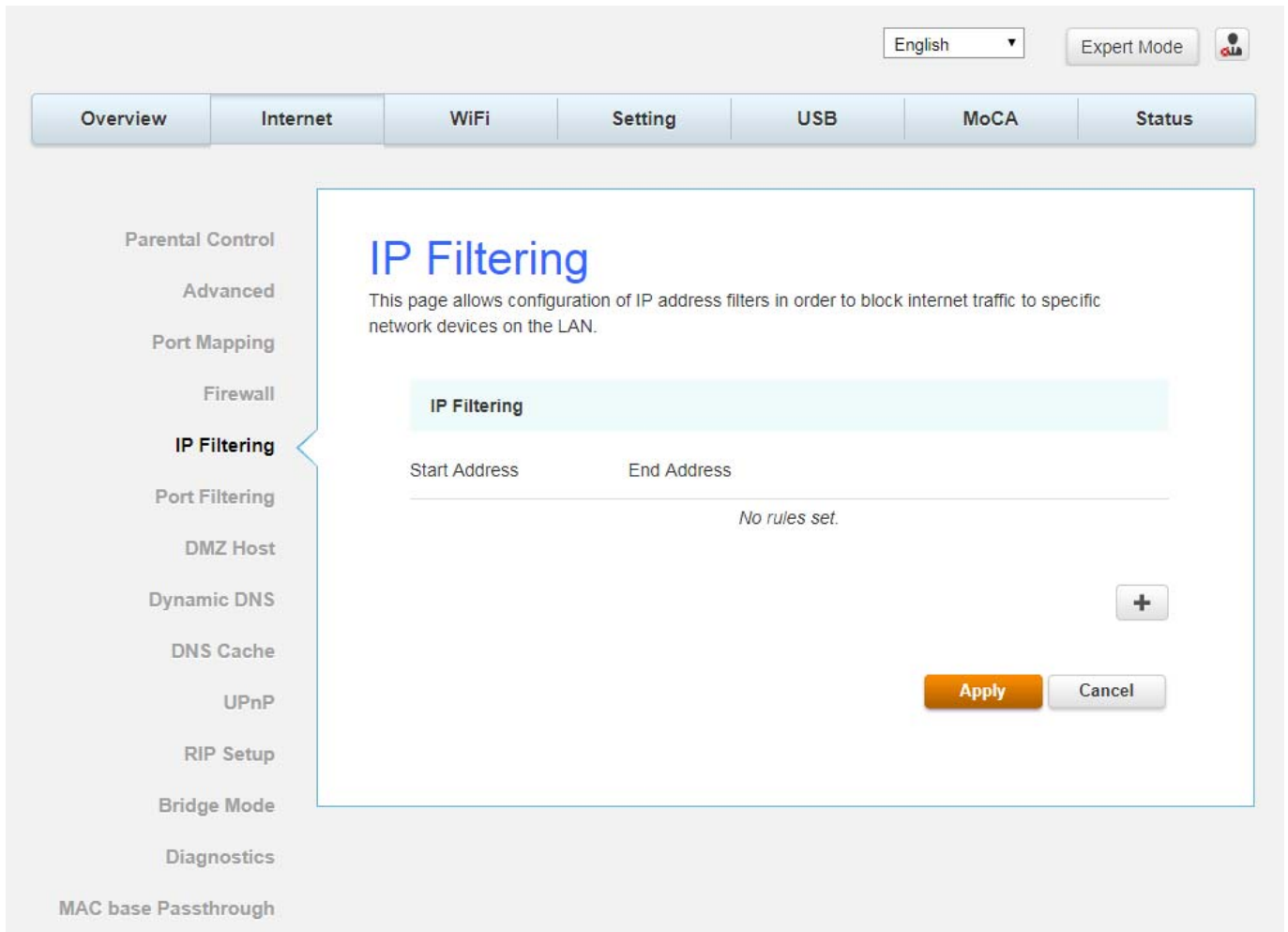

Fig.2-30 Internet\IP Filtering

## Port Filtering

This page enables you to enter the IP address ranges of PCs on your LAN that you don't want to have outbound access to the WAN. These PCs can still communicate with each other on your LAN, but packets they send to WAN addresses are blocked by the gateway.

The screenshot shows a web interface for configuring a router. At the top right, there is a language dropdown set to 'English', an 'Expert Mode' button, and a user profile icon. Below this is a navigation bar with tabs for 'Overview', 'Internet', 'WiFi', 'Setting', 'USB', 'MoCA', and 'Status'. The 'Internet' tab is selected. On the left side, there is a sidebar menu with various settings: 'Parental Control', 'Advanced', 'Port Mapping', 'Firewall', 'IP Filtering', 'Port Filtering' (highlighted with a blue bracket), 'DMZ Host', 'Dynamic DNS', 'DNS Cache', 'UPnP', 'RIP Setup', 'Bridge Mode', 'Diagnostics', and 'MAC base Passthrough'. The main content area is titled 'Port Filtering' in blue. Below the title is a descriptive text: 'This page allows configuration of port filters in order to block specific internet services to all devices on the LAN.' A table with the following columns is shown: 'Start Port', 'End Port', 'Protocol', and 'Enabled'. The table is currently empty, with the text 'No rules set.' centered below the header. At the bottom right of the table area, there is a '+' button to add a new rule, and 'Apply' and 'Cancel' buttons.

Fig.2-31 Internet\IP Filtering

## DMZ Host

Use this page to designate one PC on your LAN that should be left accessible to all PCs from the WAN side, for all ports. e.g., if you put an HTTP server on this machine, anyone will be able to access that HTTP server by using your gateway IP address as the destination.

The screenshot shows the 'DMZ Host' configuration page in a router's web interface. The interface includes a top navigation bar with tabs for Overview, Internet, WiFi, Setting, USB, MoCA, and Status. A left sidebar lists various settings, with 'DMZ Host' highlighted. The main content area is titled 'DMZ' and contains the following elements:

- A description: "If you have a local client PC that cannot run an Internet application properly from behind the NAT firewall, you can open the client to unrestricted two-way Internet access by defining a Virtual Exposed Host."
- A 'DMZ Function' toggle switch set to 'ON'.
- A warning box: "Warning: By using the exposed host function you bypass the firewall of your router. Please make sure that your computer is protected against attacks from internet."
- Text: "One PC can be exposed to the Internet for two-way communications e.g. Internet gaming, video conferencing, or VPN connections. To use the Exposed Host, you must set a static IP address for that PC."
- A table for 'Connect Devices':

Connect Devices	IP Address	MAC Address
	192.168.0.50	00:19:5b:fe:17:14
- Fields for 'Public IP Address' (10.10.144.59) and 'IP Address' (192.168.0.10).
- 'Apply' and 'Cancel' buttons.

Fig.2-32 Internet\DMZ Host

## Dynamic DNS

This page allows to setup for Dynamic DNS server.

The screenshot shows a router's web interface with the 'Dynamic DNS' configuration page selected. The page title is 'DynDNS' and it includes a sub-header: 'This page allows setup of Dynamic DNS service.' The configuration options are as follows:

- Dynamic DNS:** A toggle switch is currently set to 'ON'.
- Provider:** A dropdown menu is set to 'DynDNS.org'.
- Domain Name:** An empty text input field.
- Account / Email:** An empty text input field.
- Password:** An empty text input field.
- DDNS Status:** A label with no associated input field.

At the bottom of the configuration area, there are two buttons: 'Apply' (orange) and 'Cancel' (grey). The left sidebar contains a menu with the following items: Parental Control, Advanced, Port Mapping, Firewall, IP Filtering, Port Filtering, DMZ Host, **Dynamic DNS** (highlighted), DNS Cache, UPnP, RIP Setup, Bridge Mode, Diagnostics, and MAC base Passthrough. The top navigation bar includes 'Overview', 'Internet', 'WiFi', 'Setting', 'USB', 'MoCA', and 'Status'. The top right corner shows 'English' as the language and 'Expert Mode' as the user level.

Fig.2-33 Internet\Dynamic DNS

- **Dynamic DNS-** Turn "ON" to enable the dynamic DNS function.
- **Provider-** Choose Provider to enable the basic setting.
- **Domain Name-** The domain name that you registered with your DDNS provider.
- **Account / Email-** The account that is registered with your DDNS provider.
- **Password-** The password that you registered with your DDNS provider

Click **Apply** to save the changes.

## DNS Cache

This page allows configuration static DNS in DNS proxy mode. Enter the domain name in plain format (Ex. mydomain.com)

The screenshot shows a web interface for configuring the DNS Cache. At the top right, there is a language dropdown set to 'English', an 'Expert Mode' button, and a user profile icon. Below this is a navigation bar with tabs for 'Overview', 'Internet', 'WiFi', 'Setting', 'USB', 'MoCA', and 'Status'. The 'Internet' tab is selected. On the left side, there is a sidebar menu with various settings: Parental Control, Advanced, Port Mapping, Firewall, IP Filtering, Port Filtering, DMZ Host, Dynamic DNS, **DNS Cache** (highlighted), UPnP, RIP Setup, Bridge Mode, Diagnostics, and MAC base Passthrough. The main content area is titled 'DNS Cache' and contains the following text: 'This page allows configuration static dns in dns proxy mode. Enter the domain name in plain format (Ex. mydomain.com)'. Below this is a table with two columns: 'Host Name' and 'IP Address'. The table is currently empty, with the text 'No rules set.' centered below the columns. To the right of the table is a '+' button for adding new rules. At the bottom right of the main content area are 'Apply' and 'Cancel' buttons.

Fig.2-34 Internet\DNS Cache

## UPnP

Enable IGD UPnP to allow any local UPnP control point to perform a variety of actions, include retrieving the external IP address of the device, enumerate existing port mappings, and add or remove port mappings.

The screenshot shows the UPnP configuration page in a network router's web interface. The page is titled "UPnP" and includes a navigation menu on the left with options like Parental Control, Advanced, Port Mapping, Firewall, IP Filtering, Port Filtering, DMZ Host, Dynamic DNS, DNS Cache, UPnP (selected), RIP Setup, Bridge Mode, Diagnostics, and MAC base Passthrough. The main content area features a header with "UPnP" and a description: "Enable IGD UPnP to allow any local UPnP control point to perform a variety of actions, include retrieving the external IP address of the device, enumerate existing port mappings, and add or remove port mappings." Below this is a warning box: "We recommend you, for security reasons, to deactivate these services when you are not using them". The UPnP toggle switch is currently set to "ON". There are input fields for "Notification Interval Minutes" (30) and "Time To Live" (4). A section titled "UPnP Port Mapping" contains a table with columns: Service Name, LAN IP, Protocol, Private Port, and Public Port. At the bottom right, there are "Apply" and "Cancel" buttons.

Service Name	LAN IP	Protocol	Private Port	Public Port
--------------	--------	----------	--------------	-------------

Fig.2-35 Internet\UPnP



## RIP Setup

This page allows configuration of RIP parameters related to authentication, destination IP address, and reporting intervals. RIP is used in WAN networks to identify and use the best known and quickest route to given destination addresses to help reduce congestion and delays.

The screenshot shows the 'RIP Setup' configuration page. At the top, there are tabs for 'Overview', 'Internet', 'WiFi', 'Setting', 'USB', 'MoCA', and 'Status'. The 'Internet' tab is selected. On the left, a sidebar lists various settings, with 'RIP Setup' highlighted. The main content area is titled 'Routing -- RIP Configuration' and includes a descriptive paragraph. Below this, there are two tables: 'Route Table' and 'IP Interface RIP Configuration Table'. Both tables currently show 'No rules set.' and have a '+' button to add new entries. At the bottom, there are four toggle switches: 'Enable RIP' (OFF), 'Advertisement Timer' (30), 'Enable NAT RIP Routed Subnet' (OFF), and 'Enable WAN Provisioning' (ON). A notice box at the bottom states: 'Notice: Use proxy mode when disable WAN Provisioning'. 'Apply' and 'Cancel' buttons are located at the bottom right.

Fig.2-36 Internet\RIP Setup

## Bridge Mode

This page displays configuration Bridge Mode to internet.

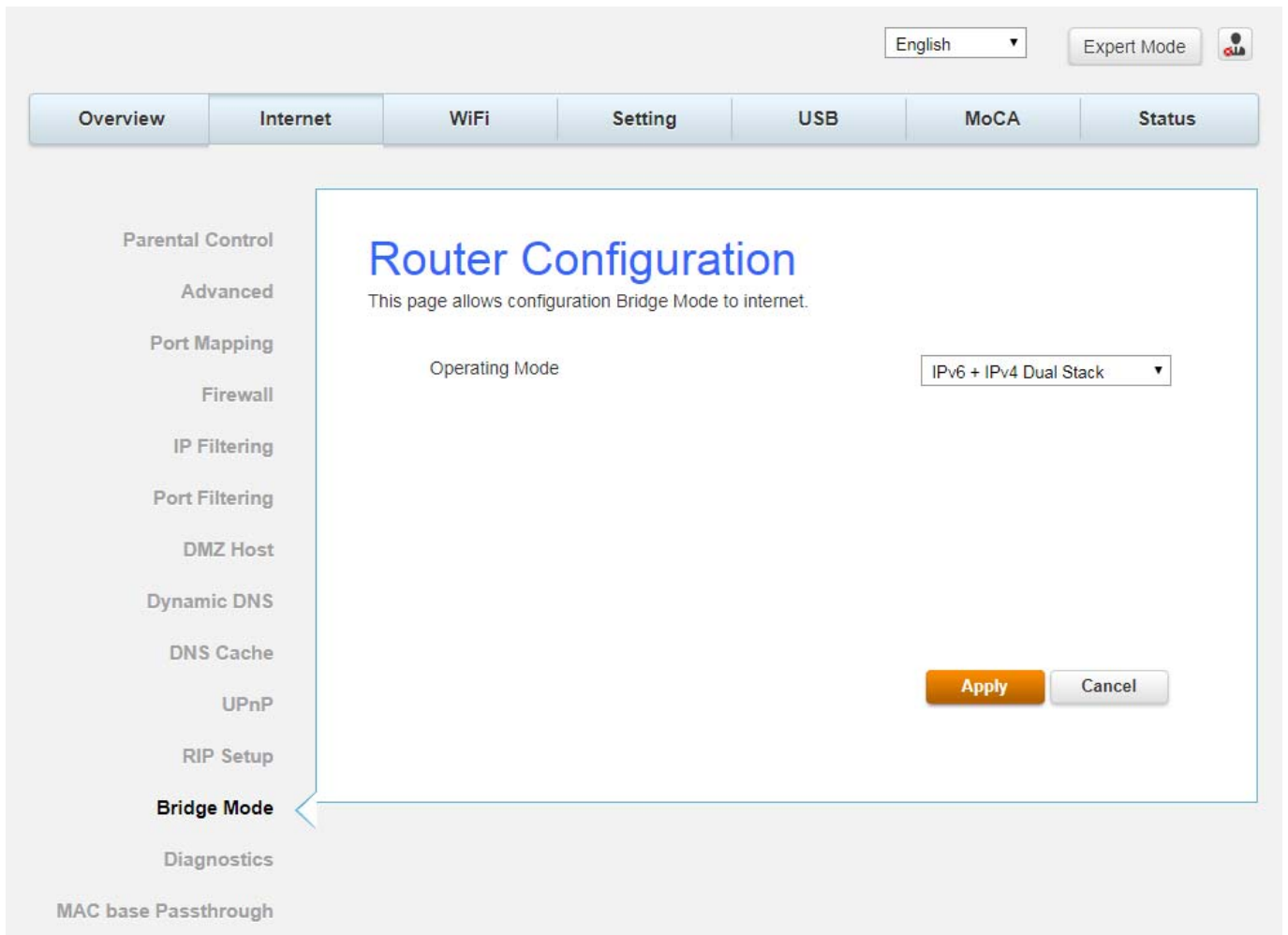

Fig.2-37 Internet\Bridge Mode

## Diagnostic

This page offers basic diagnostic tools for you to use when connectivity problems occur. When you ping an Internet device, you send a packet to its TCP/IP stack, and it sends one back to yours. To use the ping Test, enter the information needed and press Start Test; the Result will be displayed in the lower part of the window. Press Abort Test to stop, and Clear Results to clear the result contents.

Note: Firewalls may cause pings to fail but still provide you TCP/IP access to selected devices behind them. Keep this in mind when ping a device that may be behind a firewall. Ping is most useful to verify connectivity with PCs which do not have firewalls, such as the PCs on your LAN side.

The screenshot shows a web interface for a router's Internet settings. At the top right, there is a language dropdown set to 'English', an 'Expert Mode' button, and a user profile icon. Below this is a navigation bar with tabs for 'Overview', 'Internet', 'WiFi', 'Setting', 'USB', 'MoCA', and 'Status'. The 'Internet' tab is selected. On the left side, there is a sidebar menu with various settings: 'Parental Control', 'Advanced', 'Port Mapping', 'Firewall', 'IP Filtering', 'Port Filtering', 'DMZ Host', 'Dynamic DNS', 'DNS Cache', 'UPnP', 'RIP Setup', 'Bridge Mode', 'Diagnostics' (which is highlighted with a blue arrow), and 'MAC base Passthrough'. The main content area is titled 'Diagnostic' and contains the following elements:

- A sub-header 'Diagnostic Utility' with a dropdown menu set to 'Ping'.
- A section titled 'Ping Test Parameters' with three input fields:
  - 'Target' (empty)
  - 'Ping Size' (set to 56)
  - 'Number of Pings' (set to 3)
- A section titled 'Ping Test Results' with a large empty rectangular box for displaying the test results.
- At the bottom right, three orange buttons: 'Start Test', 'Abort Test', and 'Clear Results'.

Fig.2-38 Internet\Diagnostic

## MAC base Passthrough

This page allows you configure passthrough CPEs via MAC address. (bypass NAT)

The screenshot shows a web-based configuration interface for a network device. At the top right, there is a language dropdown set to 'English', an 'Expert Mode' button, and a user profile icon. Below this is a horizontal navigation bar with tabs for 'Overview', 'Internet', 'WiFi', 'Setting', 'USB', 'MoCA', and 'Status'. The 'Internet' tab is selected. On the left side, a vertical sidebar lists various configuration options: Parental Control, Advanced, Port Mapping, Firewall, IP Filtering, Port Filtering, DMZ Host, Dynamic DNS, DNS Cache, UPnP, RIP Setup, Bridge Mode, and Diagnostics. The 'MAC base Passthrough' option is highlighted with a blue arrow. The main content area is titled 'MAC base Passthrough' and contains the text: 'This page allows you configure passthrough CPEs via MAC address (bypass NAT)'. Below this is a section titled 'MAC Address List' with a light blue background. It features a text input field labeled 'MAC Address' and a horizontal line below it. The text 'No rules set.' is centered below the line. To the right of the line is a '+' button. At the bottom right of the main content area are two buttons: 'Apply' (orange) and 'Cancel' (grey). At the bottom left of the sidebar, the text 'MAC base Passthrough' is followed by a blue arrow pointing left.

Fig.2-39 Internet\MAC base Passthrough

## Wi-Fi Web Page Group

### Schedule

Schedule the times when you want the Wi-Fi of your router to be turned on or off. When it is turned back on, you return to your chosen Wi-Fi settings.

The screenshot shows the 'Schedule' configuration page within a router's web interface. At the top, there is a language dropdown set to 'English' and an 'Expert Mode' button. Below this is a navigation bar with tabs for 'Overview', 'Internet', 'WiFi', 'Setting', 'USB', 'MoCA', and 'Status'. The 'WiFi' tab is selected. On the left side, a sidebar menu lists various settings: 'General', 'Guest Network', 'Schedule' (highlighted), 'WPS', 'MAC Filter', 'WiFi Clients', 'WiFi Radar', 'Reset', and 'WMM'. The main content area is titled 'Schedule' and contains the following elements:

- A descriptive paragraph: "Schedule the times when you want the WiFi of your router to be turned on or off. When it is turned back on, you return to your chosen WiFi settings."
- A 'Schedule Function' section with a radio button for 'Enabled' (unselected) and a radio button for 'Disabled' (selected).
- A 'Schedule' section with a table header for 'Days Of Week' and 'Time'. The table is currently empty, displaying the text "No rules set." below the header.
- A plus sign button (+) to add a new rule.
- 'Apply' and 'Cancel' buttons at the bottom right.

Fig.2-40 Wi-Fi\Schedule

## MAC Filter

By entering MAC Address, you can configure which local PCs are allowed access to the WAN. Besides the list of MAC filter, any local PCs else would be blocked to the WAN.

The screenshot shows a web-based configuration interface for a network device. At the top, there is a language dropdown set to 'English' and an 'Expert Mode' button. Below this is a navigation bar with tabs for 'Overview', 'Internet', 'WiFi', 'Setting', 'USB', 'MoCA', and 'Status'. The 'WiFi' tab is selected. On the left side, a sidebar menu lists various settings: 'General', 'Guest Network', 'Schedule', 'WPS', 'MAC Filter' (which is highlighted), 'WiFi Clients', 'WiFi Radar', 'Reset', and 'WMM'. The main content area is titled 'MAC Filter' and includes a descriptive paragraph: 'This page allows configuration of the Access Control to the AP as well as status on the connected clients.' There are two main sections for configuration: 'WiFi 2.4G MAC Address to Allow/Block to access Network' and 'WiFi 5G MAC Address to Allow/Block to access Network'. Each section contains a toggle switch for 'WiFi [2.4G/5G] MAC Address to Access Network' (both are currently 'ON'), a dropdown menu for 'WiFi [2.4G/5G] MAC Restrict Mode' (both are set to 'Allow'), and a list for 'MAC Address' which is currently empty and shows 'No device added'. Below each list is a '+' button and a link that says 'Add all currently connected devices to list'. At the bottom right of the configuration area are 'Apply' and 'Cancel' buttons.

Fig.2-41 Wi-Fi\MAC Filter

## WMM (Wi-Fi Multi-Media)

This page allows you to configure Wi-Fi Multi-Media (WMM). WMM is an implementation of Quality of Service (QoS) which is defined by the IEEE standard 802.11e.

The screenshot shows a network management interface with a top navigation bar containing 'Overview', 'Internet', 'WiFi', 'Setting', 'USB', 'MoCA', and 'Status'. A language dropdown is set to 'English' and 'Expert Mode' is selected. The left sidebar lists various settings, with 'WMM' highlighted. The main content area is titled 'Wi-Fi Multimedia' and includes a description: 'This page allows configuration of the Wi-Fi Multimedia QoS.' Below this, there are two sections: '2.4G Wi-Fi Multimedia' and '5G Wi-Fi Multimedia'. Each section has three toggle switches: 'WMM Support' (ON), 'No-Acknowledgement' (OFF), and 'Power Save Support' (ON). At the bottom right, there are 'Apply' and 'Cancel' buttons.

Fig.2-42 Wi-Fi\WMM

- **WMM Support-** If enabled, the WMM information Element is included in beacon frame.
- **No-Acknowledgement-** When enabled, acknowledgment for data are not transmitted.
- **Power Save Support-** When Power Save is enabled, the AP queues packets for STAs that are in power-save mode. Queued packets are transmitted when the STA notifies AP that it has left power-save mode.

## Settings Web Page Group

### Remote Access

This page allows configuration of the Remote Access.

The screenshot shows a web interface for configuring Remote Access. At the top right, there is a language dropdown set to 'English', an 'Expert Mode' button, and a user profile icon. Below this is a navigation bar with tabs for 'Overview', 'Internet', 'WiFi', 'Setting' (selected), 'USB', 'MoCA', and 'Status'. On the left side, a sidebar menu lists 'Language', 'Password', 'Configuration', 'LAN', 'Remote Access' (highlighted), 'Internet Time', and 'LED'. The main content area is titled 'Remote Access' and contains the following configuration options:

- Allow Remote Management:** A toggle switch currently set to 'OFF'.
- Remote User Name:** A text input field containing 'remote'.
- Port Number:** A text input field containing '80'.
- Remote Password:** A text input field with masked characters '.....'. Below it is a 'Display Characters' checkbox (unchecked) and a 'Change Key' button.
- IP Address:** A text input field containing 'http://10.10.144.59:80'.

At the bottom right of the configuration area, there are two buttons: 'Apply' (highlighted in orange) and 'Cancel'.

Fig. 2-43 Setting\Remote Access

- **Allow Remote Management:** It may help you to **Enable** or **Disable** the remote access function.
- **Remote User Name:** The user name that when you remote access able to login.
- **Port Number:** Configure specific port number when you remote access to GUI.
- **Remote Password:** The remote password that when you remote access able to login.
- **IP Address:** The IP address that you can use to remote access.



## Internet Time

This page displays configuration of time servers and the system time obtained from network servers via Simple Network Time Protocol. The system has to be reset for any changes to take effect.

The screenshot shows a web interface for configuring the modem's Internet Time. At the top right, there is a language dropdown set to 'English' and an 'Expert Mode' button. Below this is a navigation bar with tabs for 'Overview', 'Internet', 'WiFi', 'Setting', 'USB', 'MoCA', and 'Status'. On the left side, a sidebar menu lists 'Language', 'Password', 'Configuration', 'LAN', 'Remote Access', 'Internet Time' (which is highlighted), and 'LED'. The main content area is titled 'Internet Time' and includes a sub-header 'Time Settings'. It features a toggle switch for 'Automatically synchronize with Internet time servers' which is currently turned 'ON'. Below this are five rows for NTP time servers, each with a dropdown menu and an adjacent text input field. The first NTP time server is set to 'clock.fmt.he.net', while the others are set to 'None'. The 'Time zone offset' is set to '(GMT+08:00) Beijing, Chongqing, Hong Kong, Urumqi'. At the bottom right of the configuration area are 'Apply' and 'Cancel' buttons.

Fig.2-44 Setting\Internet Time

## USB Web Page Group

---

### USB Basic

This page allows basic control of the USB devices shared over the network.

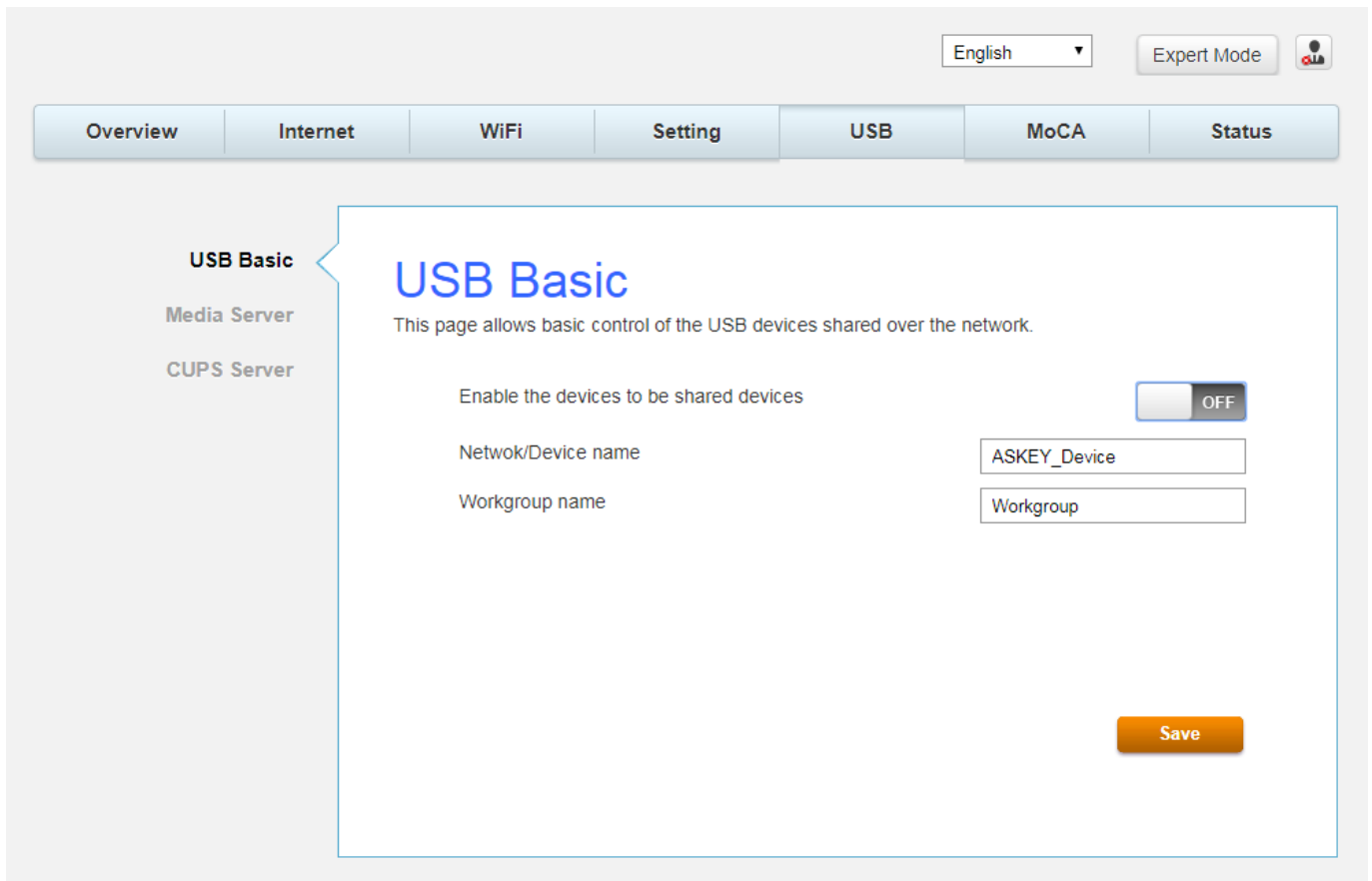

The screenshot shows a web interface for configuring USB sharing. At the top right, there is a language dropdown set to 'English', an 'Expert Mode' button, and a user profile icon. Below this is a navigation bar with tabs for 'Overview', 'Internet', 'WiFi', 'Setting', 'USB', 'MoCA', and 'Status'. The 'USB' tab is selected. On the left side, there is a sidebar with 'USB Basic' selected, along with 'Media Server' and 'CUPS Server'. The main content area is titled 'USB Basic' and contains the following settings:

- 'Enable the devices to be shared devices' with a toggle switch set to 'OFF'.
- 'Network/Device name' with a text input field containing 'ASKEY\_Device'.
- 'Workgroup name' with a text input field containing 'Workgroup'.
- A 'Save' button at the bottom right.

Fig.2-45 USB\USB Basic

## Media Server

This page controls configuration and scanning of the cable modem's media server.

The screenshot shows a web interface for configuring a cable modem's media server. At the top right, there is a language dropdown menu set to "English", an "Expert Mode" button, and a user profile icon. Below this is a horizontal navigation bar with tabs for "Overview", "Internet", "WiFi", "Setting", "USB", "MoCA", and "Status". The "USB" tab is selected. On the left side, there is a vertical sidebar with three options: "USB Basic", "Media Server" (which is highlighted with a blue bracket), and "CUPS Server". The main content area is titled "Media Server" in large blue font. Below the title is a subtitle: "This page controls configuration and scanning of the cable modem's media server." Underneath, there is a section titled "Basic Settings" with a light blue background. This section contains two configuration items: "Media Server" with a toggle switch currently set to "OFF", and "Media Server Name" with a text input field containing the value "ASKEY-DMS". At the bottom right of the main content area, there is an orange "Save" button.

Fig.2-46 USB\Media Server

## CPUS Server

This page allows control of the USB Printer shared over the network.

The screenshot shows a web-based configuration interface for a network device. At the top right, there is a language dropdown menu set to "English", an "Expert Mode" button, and a user profile icon. Below this is a horizontal navigation bar with tabs for "Overview", "Internet", "WiFi", "Setting", "USB", "MoCA", and "Status". The "USB" tab is selected. On the left side, there is a vertical sidebar with three menu items: "USB Basic", "Media Server", and "CUPS Server", with "CUPS Server" being the active selection. The main content area is titled "Printer Server" in blue text. Below the title, it states "This page allows control of the USB Printer shared over the network." There are three configuration options: "Enable the Printer to Share" with a toggle switch currently set to "OFF", "Printer name" with an empty text input field, and "Printer Server URL" with an empty text input field. At the bottom right of the main content area, there is an orange "Save" button.

Fig.2-47 USB\CPUS Server

## CHAPTER 3: ADDITIONAL INFORMATION

### Frequently Asked Questions

---

***Q. How do I get the system installed?***

A. Professional installation from your cable provider is strongly recommended. They will ensure proper cable connection to the modem and your computer. However, your retailer may have offered a self- installation kit, including the necessary software to communicate with your cable ISP.

***Q. Once my Cable Modem is connected, how do I get access to the Internet?***

A. Your local cable company provides your internet service\*, offering a wide range of services including email, chat, and news and information services, and a connection to the World Wide Web.

***Q. Can I watch TV, surf the Internet, and talk to my friends through the Cable Modem at the same time?***

A. Absolutely!

***Q. What do you mean by "Broadband?"***

A. Simply put, it means you'll be getting information through a "bigger pipe," with more bandwidth, than a standard phone line can offer. A wider, "broader" band means more information, more quickly.

***Q. What is DOCSIS and what does it mean?***

A. "Data over Cable Service Interface Specifications" is the industry standard that most cable companies are adopting as they upgrade their systems. Should you ever decide to move, the Cable Modem will work with all upgraded cable systems that are DOCSIS-compliant.

\* Monthly subscription fee applies.

\*\* Additional equipment required. Contact your Cable Company and ISP for any restrictions or additional fees.

## General Troubleshooting

---

You can correct most problems you have with your product by consulting the troubleshooting list that follows.

### **I can't access the internet.**

- Check all of the connections to your Cable Modem.
- Your Ethernet card may not be working. Check each product's documentation for more information.
- The Network Properties of your operating system may not be installed correctly or the settings may be incorrect. Check with your ISP or cable company.

### **I can't get the modem to establish an Ethernet connection.**

- Even new computers don't always have Ethernet capabilities – be sure to verify that your computer has a properly installed Ethernet card and the driver software to support it.
- Check to see that you are using the right type of Ethernet cable.

### **The modem won't register a cable connection.**

- If the modem is in Initialization Mode, the INTERNET light will be flashing. Call your Cable Company if it has not completed this 5-step process within 30 minutes, and note which step it is getting stuck on.
- The modem should work with a standard RG-6 coaxial cable, but if you're using a cable other than the one your Cable Company recommends, or if the terminal connections are loose, it may not work. Check with your Cable Company to determine whether you're using the correct cable.
- If you subscribe to video service over cable, the cable signal may not be reaching the modem. Confirm that good quality cable television pictures are available to the coaxial connector you are using by connecting a television to it. If your cable outlet is "dead", call your Cable Company.
- Verify that the Cable Modem service is DOCSIS compliant by calling your cable provider.

## **Service Information**

---

If you purchased or leased your Cable Modem directly from your cable company, then warranty service for the Digital Cable Modem may be provided through your cable provider or its authorized representative. For information on 1) Ordering Service, 2) Obtaining Customer Support, or 3) Additional Service Information, please contact your cable company. If you purchased your Cable Modem from a retailer, see the enclosed warranty card.

## **Federal Communication Commission Interference Statement**

---

This device complies with Part 15 of the FCC Rules. Operation is subject to the following two conditions: (1) This device may not cause harmful interference, and (2) this device must accept any interference received, including interference that may cause undesired operation.

This equipment has been tested and found to comply with the limits for a Class B digital device, pursuant to Part 15 of the FCC Rules. These limits are designed to provide reasonable protection against harmful interference in a residential installation. This equipment generates, uses and can radiate radio frequency energy and, if not installed and used in accordance with the instructions, may cause harmful interference to radio communications. However, there is no guarantee that interference will not occur in a particular installation. If this equipment does cause harmful interference to radio or television reception, which can be determined by turning the equipment off and on, the user is encouraged to try to correct the interference by one of the following measures:

- Reorient or relocate the receiving antenna.
- Increase the separation between the equipment and receiver.
- Connect the equipment into an outlet on a circuit different from that to which the receiver is connected.
- Consult the dealer or an experienced radio/TV technician for help.

FCC Caution: Any changes or modifications not expressly approved by the party responsible for compliance could void the user's authority to operate this equipment.

This transmitter must not be co-located or operating in conjunction with any other antenna or transmitter.

For operation within 5.15 ~ 5.25GHz / 5.47 ~5.725GHz frequency range, it is restricted to indoor environment. This device meets all the other requirements specified in Part 15E, Section 15.407 of the FCC Rules.



## **FOR MOBILE DEVICE USAGE (>35cm/low power)**

### **Radiation Exposure Statement:**

This equipment complies with FCC radiation exposure limits set forth for an uncontrolled environment. This equipment should be installed and operated with minimum distance 35cm between the radiator & your body.

## **FOR COUNTRY CODE SELECTION USAGE (WLAN DEVICES)**

Note: The country code selection is for non-US model only and is not available to all US model. Per FCC regulation, all Wi-Fi products marketed in US must fix to US operation channels only.

## **Industry Canada statement:**

---

This device complies with ISED's licence-exempt RSSs. Operation is subject to the following two conditions: (1) This device may not cause harmful interference, and (2) this device must accept any interference received, including interference that may cause undesired operation.

Le présent appareil est conforme aux CNR d'ISED applicables aux appareils radio exempts de licence. L'exploitation est autorisée aux deux conditions suivantes : (1) le dispositif ne doit pas produire de brouillage préjudiciable, et (2) ce dispositif doit accepter tout brouillage reçu, y compris un brouillage susceptible de provoquer un fonctionnement indésirable.

### **Caution :**

- (i) the device for operation in the band 5150-5250 MHz is only for indoor use to reduce the potential for harmful interference to co-channel mobile satellite systems;
- (ii) the maximum antenna gain permitted for devices in the bands 5250-5350 MHz and 5470-5725 MHz shall be such that the equipment still complies with the e.i.r.p. limit;
- (iii) the maximum antenna gain permitted for devices in the band 5725-5850 MHz shall be such that the equipment still complies with the e.i.r.p. limits specified for point-to-point and non-point-to-point operation as appropriate; and
- (v) Users should also be advised that high-power radars are allocated as primary users (i.e. priority users) of the bands 5250-5350 MHz and 5650-5850 MHz and that these radars could cause interference and/or damage to LE-LAN devices.

### **Avertissement:**

Le guide d'utilisation des dispositifs pour réseaux locaux doit inclure des instructions précises sur les restrictions susmentionnées, notamment :

- (i) les dispositifs fonctionnant dans la bande 5150-5250 MHz sont réservés uniquement pour une utilisation à l'intérieur afin de réduire les risques de brouillage préjudiciable aux systèmes de satellites mobiles utilisant les mêmes canaux;
- (ii) le gain maximal d'antenne permis pour les dispositifs utilisant les bandes de 5250 à 5350 MHz et de 5470 à 5725 MHz doit être conforme à la limite de la p.i.r.e.;
- (iii) le gain maximal d'antenne permis (pour les dispositifs utilisant la bande de 5725 à 5850 MHz) doit être conforme à la limite de la p.i.r.e. spécifiée pour l'exploitation point à point et l'exploitation non point à point, selon le cas;

(v) De plus, les utilisateurs devraient aussi être avisés que les utilisateurs de radars de haute puissance sont désignés utilisateurs principaux (c.-à-d., qu'ils ont la priorité) pour les bandes 5250-5350 MHz et 5650-5850 MHz et que ces radars pourraient causer du brouillage et/ou des dommages aux dispositifs LAN-EL.

## **FOR MOBILE DEVICE USAGE (>35cm/low power)**

### **Radiation Exposure Statement:**

This equipment complies with ISED radiation exposure limits set forth for an uncontrolled environment. This equipment should be installed and operated with minimum distance 35cm between the radiator & your body.

### **Déclaration d'exposition aux radiations:**

Cet équipement est conforme aux limites d'exposition aux rayonnements ISED établies pour un environnement non contrôlé. Cet équipement doit être installé et utilisé avec un minimum de 35 cm de distance entre la source de rayonnement et votre corps.

**CAUTION for UL (Check caution label on gift box)**

---

**North American Cable Installer:**

This reminder is provided to call your attention to Article 820.93 of the National Electrical Code (Section 54 of the Canadian Electrical Code, Part 1) which provides guidelines for proper grounding and, in particular, specifies that the cable ground shall be connected to the grounding system of the building as close to the point of cable entry as practical.