

Aspire

easyStore H340

Service Guide

Service guide files and updates are available on the ACER/CSD web; for more information, please refer to <http://csd.acer.com.tw>

PRINTED IN TAIWAN

Revision History

Please refer to the table below for the updates made on Aspire easyStore H340 service guide.

Date	Chapter	Updates

Copyright

Copyright © 2009 by Acer Incorporated. All rights reserved. No part of this publication may be reproduced, transmitted, transcribed, stored in a retrieval system, or translated into any language or computer language, in any form or by any means, electronic, mechanical, magnetic, optical, chemical, manual or otherwise, without the prior written permission of Acer Incorporated.

Disclaimer

The information in this guide is subject to change without notice.

Acer Incorporated makes no representations or warranties, either expressed or implied, with respect to the contents hereof and specifically disclaims any warranties of merchantability or fitness for any particular purpose. Any Acer Incorporated software described in this manual is sold or licensed "as is". Should the programs prove defective following their purchase, the buyer (and not Acer Incorporated, its distributor, or its dealer) assumes the entire cost of all necessary servicing, repair, and any incidental or consequential damages resulting from any defect in the software.

Acer is a registered trademark of Acer Corporation.

Intel is a registered trademark of Intel Corporation.

Other brand and product names are trademarks and/or registered trademarks of their respective holders.

Conventions

The following conventions are used in this manual:

SCREEN MESSAGES	Denotes actual messages that appear on screen.
NOTE	Gives additional information related to the current topic.
WARNING	Alerts you to any physical risk or system damage that might result from doing or not doing specific actions.
CAUTION	Gives precautionary measures to avoid possible hardware or software problems.
IMPORTANT	Reminds you to do specific actions relevant to the accomplishment of procedures.

Service Guide Coverage

This Service Guide provides you with all technical information relating to the BASIC CONFIGURATION decided for Acer's "global" product offering. To better fit local market requirements and enhance product competitiveness, your regional office MAY have decided to extend the functionality of a machine (e.g. add-on card, modem, or extra memory capability). These LOCALIZED FEATURES will NOT be covered in this generic service guide. In such cases, please contact your regional offices or the responsible personnel/channel to provide you with further technical details.

FRU Information

Please note WHEN ORDERING FRU PARTS, that you should check the most up-to-date information available on your regional web or channel. If, for whatever reason, a part number change is made, it will not be noted in the printed Service Guide. For ACER-AUTHORIZED SERVICE PROVIDERS, your Acer office may have a DIFFERENT part number code to those given in the FRU list of this printed Service Guide. You MUST use the list provided by your regional Acer office to order FRU parts for repair and service of customer machines.

Table of Contents

System Tour	1
Features	1
System Tour	2
Front Panel	2
Rear Panel	3
Internal Components	4
System LED Indicators	5
System Utilities	9
Phoenix BIOS Setup Utility	9
Entering BIOS setup	10
Navigating Through the Setup Utility	11
Setup Utility Menus	12
System Disassembly	21
Disassembly Requirements	21
Pre-disassembly Procedure	22
Main Unit Disassembly	23
Removing the Hard Disk	24
Removing the System Cover	27
Removing the Front Bezel	28
Removing the Front I/O Board	30
Removing the Backplane Board	32
Removing the Power Supply	35
Removing the System Fan	38
Removing the Memory Module	39
Removing the Mainboard	41
Removing the HDD Access LED cables	42
System Troubleshooting	43
Hardware Diagnostic Procedure	43
H340 Diagnostics	44
System Check Procedures	46
Power System Check	46
System External Inspection	46
System Internal Inspection	46
Error Codes	47
Online Support Information	48
System Block Diagram and Board Layout	49
System Block Diagram	49
Board Layout	50
Mainboard	50
System Jumpers	51
FRU (Field Replaceable Unit) List	53
Exploded Diagram	54
FRU List	56
Technical Specifications	59

System Tour

Features

Below is a brief summary of the home server's many feature:

NOTE: The features listed in this section is for your reference only. The exact configuration of the server depends on the model purchased.

Processor

- Intel Atom processor

Chipset

- Intel 945GC Express Chipset and ICH7R

Memory subsystem

- Supports DDR2 unbuffered SDRAM

Media storage

- Up to four 3.5-inch hot-swappable SATA hard disk drives

Networking

- One Gigabit Ethernet LAN port (RJ-45)

I/O ports

- USB 2.0 ports (1 front and 4 rear)
- Gigabit LAN port
- eSATA port

Power supply

- 200-watts (100/240 Vac) power supply

Operating system and software

- Operating system:
 - ✦ Windows Home Server
- Applications
 - ✦ Windows Home Server Connector
 - ✦ Lights Out Client
 - ✦ Software Update
 - ✦ Server Recovery
 - ✦ PC Recovery

Physical dimensions

- WxHxD: 200 x 180 x 212 mm
- Weight (without HDD): 4.5 kg (with 1 HDD): 5.1 kg

System Tour

This section is a virtual tour of the system's interior and exterior components.

Front Panel



No.	Icon	Component
1		Power button/power indicator
2		Network indicator
3		Hard disk drive (HDD) status indicator
4		System status indicator
5		USB backup button/USB backup indicator
6		USB 2.0 port
7		Front door Open the door to access the hot-swappable HDDs.
8		HDD access indicators

Rear Panel



No.	Icon	Component
1	▶◀	Recovery/reset button
2	e SATA	eSATA port
3	⚡	Gigabit Ethernet port
4	USB	USB ports
5		Power connector
6		System fan

Internal Components





No.	Component
1	Backplane board
2	Power supply
3	Memory module
4	Mainboard

System LED Indicators

Front panel



This section describes the different system LED indicators.

No.	LED indicator	Color	LED status	Description
1		Blue	On	System is connected to the power supply and turned on and ready for use.
			Random blink	<ul style="list-style-type: none"> System is booting System is in S3 sleep state (suspend to memory)
		None	Off	<ul style="list-style-type: none"> System is not powered on System initialize operation in progress
2		Blue	On	Link between system and network
			Random blink	Network access
		Red	Off	Network disconnected
3		Purple	On	<ul style="list-style-type: none"> System not initialized HDD is not mounted into the drive bay
			Random blink	<ul style="list-style-type: none"> HDD is mounted into the drive bay and is in the process of being manually added into the server storage HDD is in the process of being removed from the server storage.
				HDD is mounted into the drive bay and added into the server storage
		Red	Random blink	<ul style="list-style-type: none"> HDD failure Windows Home Server cannot find HDD
		None	Off	No HDD mounted in the drive bay

No.	LED indicator	Color	LED status	Description
4	System status i	Blue	Random blink	<ul style="list-style-type: none"> System is booting System is shutting down
			On	System initialize operation completed.
		Blue and purple	Random blink	System is booting from a USB device (Reserved for BIOS update while boot block has been active)
		Red	On	May indicate the following states: <ul style="list-style-type: none"> System failure HDD failure SATA controller failure USB controller failure LAN controller failure FAN failure Memory failure Boot device not found Refer to "Error Codes" on page 47 for more information.
			Random blink	System recovery or reset is in progress
5	USB device backup 	Blue	On	<ul style="list-style-type: none"> USB storage device is connected to the USB port Backup completed
			Random blink	System is backing up files from a USB storage device
			Off	USB storage device unmounted
6	HDD access	Blue	Blink	HDD is in use
			Off	No HDD activity

Rear panel



No.	LED indicator	Color	LED status	Description
1	LAN port network speed LED	Amber	On	1000 Mbps network access
		Green	On	100 Mbps link network access
		None	Off	10 Mbps link network access
2	LAN port activity LED	Green	On	Active network link
			Random blink	Transmit or receive activity
		None	Off	No network connection

System Utilities

Phoenix BIOS Setup Utility

BIOS setup is a hardware configuration program built into the system's Basic Input/Output System (BIOS). Since most systems are already properly configured and optimized, there is no need to run this utility. You will need to run this utility under the following conditions.

- When changing the system configuration settings
- When redefining the communication ports to prevent any conflicts
- When modifying the power management configuration
- When changing the password or making other changes to the security setup
- When a configuration error is detected by the system and you are prompted ("Run Setup" message) to make changes to the BIOS setup

NOTE: If you repeatedly receive Run Setup messages, the battery may be bad. In this case, the system cannot retain configuration values in CMOS. Ask a qualified technician for assistance.

BIOS setup loads the configuration values in a battery-backed nonvolatile memory called CMOS RAM. This memory area is not part of the system RAM which allows configuration data to be retained when power is turned off.

Before you run the *Phoenix*BIOS Setup Utility, make sure that you have saved all open files. The system reboots immediately after you close the Setup.

NOTE: *Phoenix*BIOS Setup Utility will be simply referred to as "Setup" or "Setup utility" in this guide.

The screenshots used in this guide display default system values. These values may not be the same those found in your system.

Entering BIOS setup

IMPORTANT: To enter the BIOS setup, you need a debug board.

1. Turn off the computer and all attached devices.
2. Remove the cover. See “Removing the System Cover” on page 27.
3. Connect the debug board cable to the debug board connector on the mainboard.

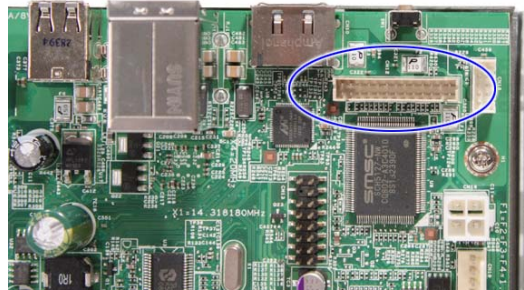

4. Locate the JP3 Debug/User mode jumper on the mainboard.

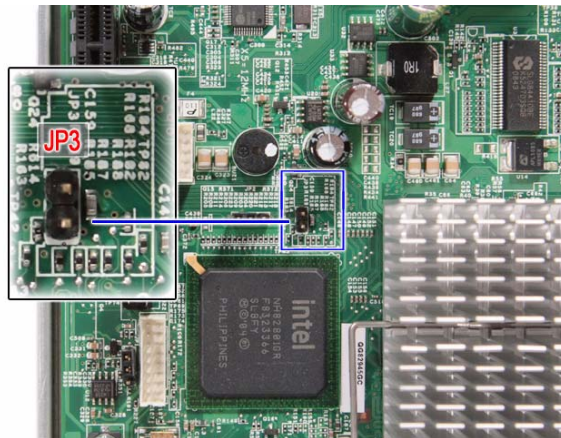

5. Close the jumper to enable system for debug mode.
6. Connect the power cable to the rear panel.
7. Connect a USB keyboard to the debug board.
8. Connect a monitor to the debug board.
9. Restart the system.
10. Turn on the monitor.
11. During POST, press **F2**.

If you fail to press **F2** before POST is completed, you will need to restart the server.

The Setup Main menu will be displayed showing the Setup's menu bar. Use the left and right arrow keys to move between selections on the menu bar.

Navigating Through the Setup Utility

Use the following keys to move around the Setup utility.

- Left** and **Right** arrow keys – Move between selections on the menu bar.
- Up** and **Down** arrow keys – Move the cursor to the field you want.
- PgUp** and **PgDn** keys – Move the cursor to the previous and next page of a multiple page menu.
- Home** – Move the cursor to the first page of a multiple page menu.
- End** – Move the cursor to the last page of a multiple page menu.
- +** and **-** keys – Select a value for the currently selected field (only if it is user-configurable). Press these keys repeatedly to display each possible entry, or the **Enter** key to choose from a pop-up menu.

NOTE: Grayed-out fields are not user-configurable.

- Enter** key – Display a submenu screen.

NOTE: Availability of submenu screen is indicated by a (>).

- Esc** – If you press this key:
 - On one of the primary menu screens, the Exit menu displays.
 - On a submenu screen, the previous screen displays.
 - When you are making selections from a pop-up menu, closes the pop-up without making a selection.
- F1** – Display the BIOS setup General Help panel.
- F5** – Press to load previous default system values.
- F6** – Press to load fail-safe default system values.
- F7** – Press to load optimized default system values.
- F10** – Save changes made the Setup and close the utility.

Setup Utility Menus

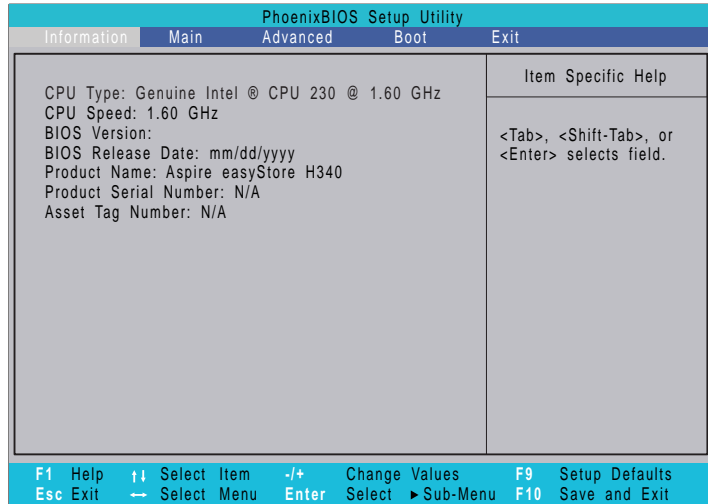

The Setup Main menu includes the following main setup categories.

- Information
- Main
- Advanced
- Boot
- Exit

In the descriptive table following each of the menu screenshots, settings in **boldface** are the default and suggested settings.

Information

The Information menu displays basic information about the system. These entries are for your reference only and are not user-configurable.

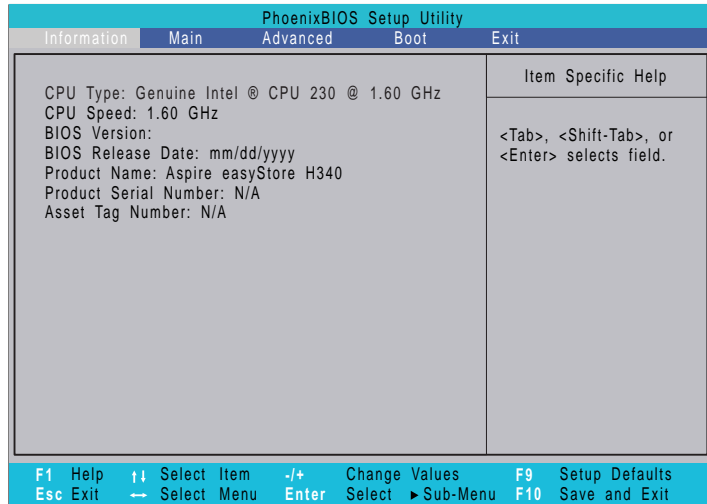

Main

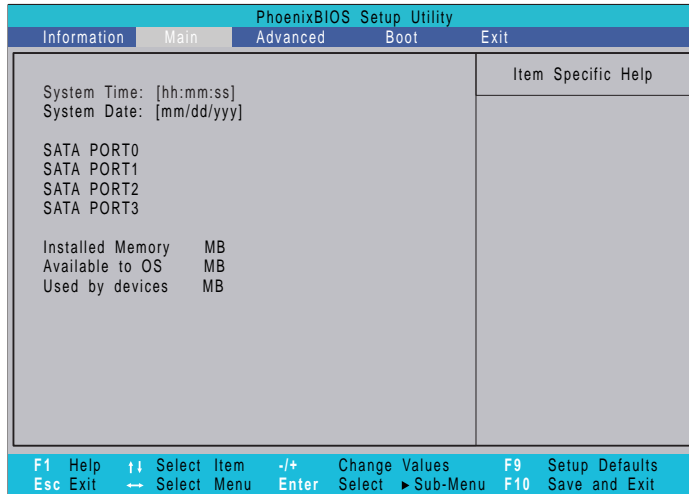

Parameter	Description
System Time	Set the system time following the hour-minute-second format.
System Date	Set the date following the month-day-year format.
SATA PORT 0 to 3	Displays SATA device status.
Installed Memory	Indicates the total size of system memory detected during POST.
Available to OS	Indicates the total size of system memory available to the operating system.
Used by devices	Indicates the total size of system memory used by devices.

Advanced

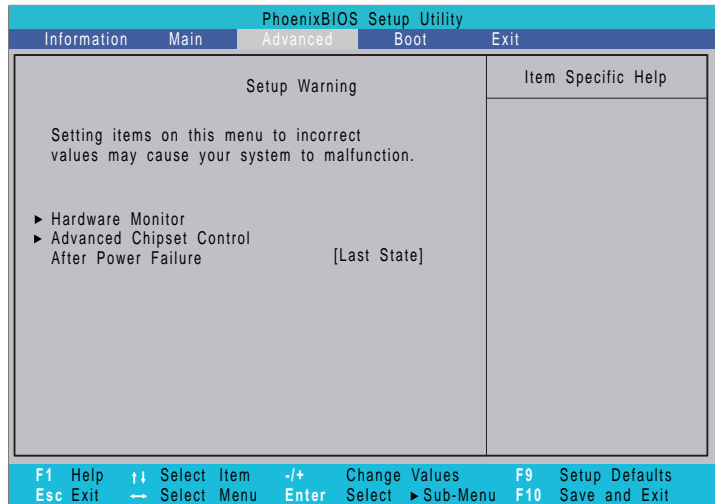

Parameter	Description	Option
Hardware Monitor	Press Enter to configure the Hardware Monitor feature.	
Advanced Chipset Control	Press Enter to select options for Advanced Chipset Control.	
After Power Failure	Defines the power state to resume to after a system shutdown that is due to an interruption in AC power. When set to Last State, the system will return to the active power state prior to shutdown. When set to Stay Off, the system remains off after power shutdown. When set to Power On, the system will be turned on from a power failure.	Last State Stay Off Power On

Hardware Monitor

The Hardware Monitor submenu displays options for measuring voltages and monitoring the system and processor temperature and fan speeds.

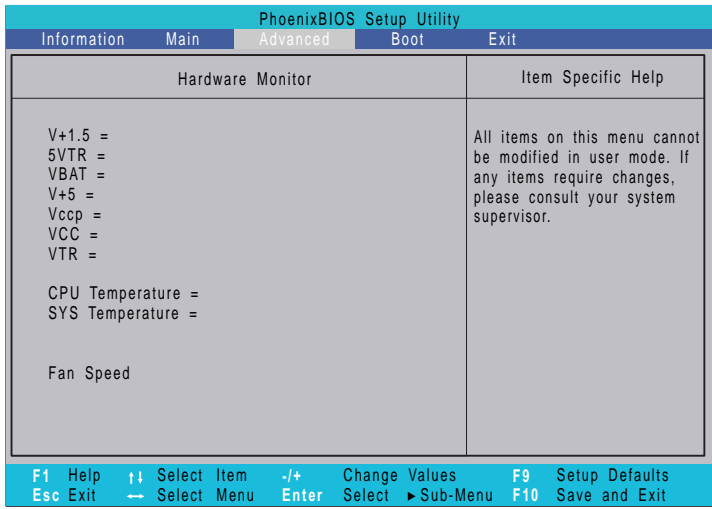

Advanced Chipset Control

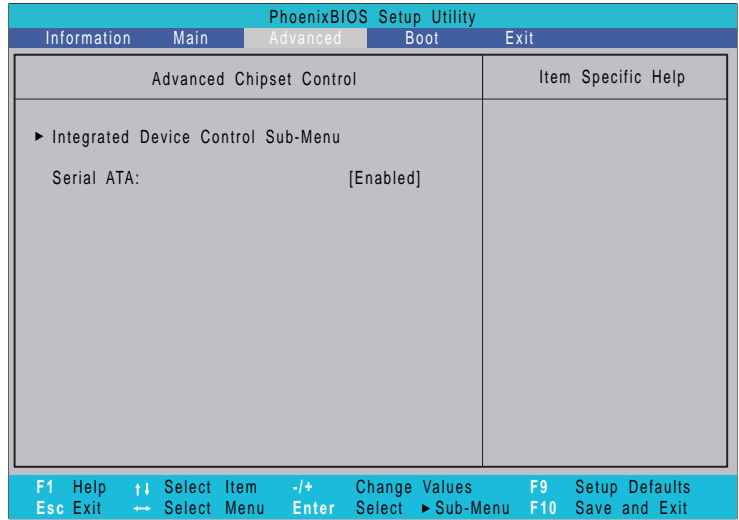

Parameter	Description	Option
Integrated Device Control Sub-Menu	Press Enter to configure the integrated device controllers.	
Serial ATA	Enables or disables the onboard SATA ports.	Enabled Disabled

Integrated Device Control Sub-Menu

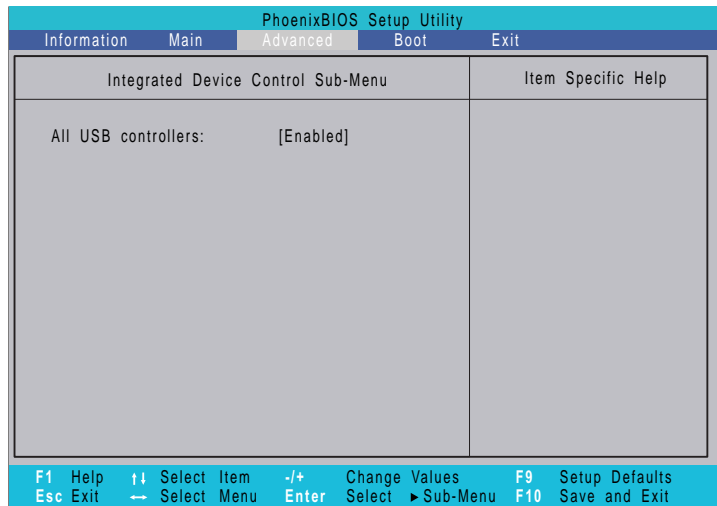

Parameter	Description	Option
All USB controllers	Enables or disables the onboard USB controllers.	Enabled Disabled

Boot

The Boot menu allows you to set the drive priority during system boot-up. BIOS setup will display an error message if the drive specified is not bootable.

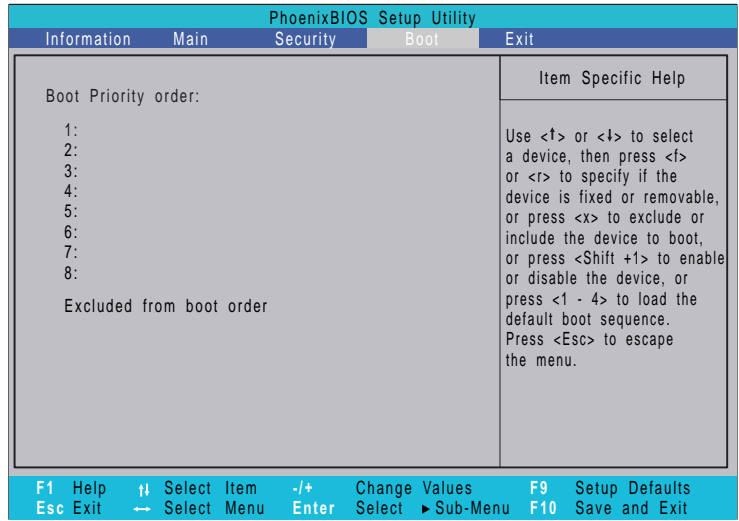

Exit

The Exit menu displays the various options to quit from the BIOS setup. Highlight any of the exit options then press **Enter**.

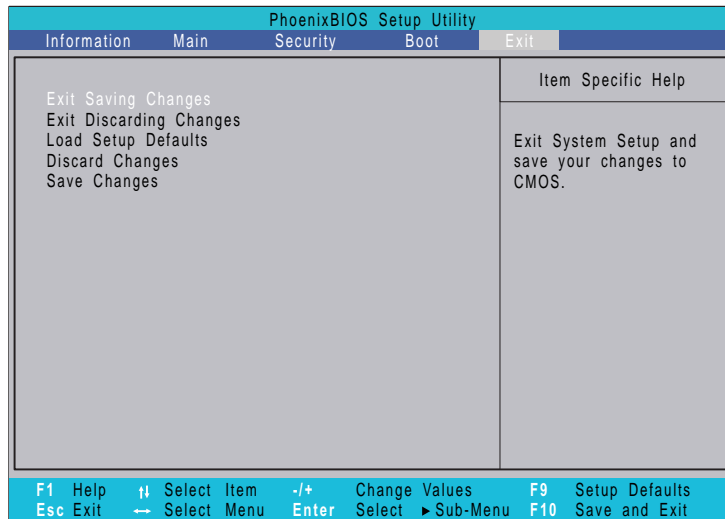

Parameter	Description
Exit Saving Changes	Saves changes made and close the BIOS setup.
Exit Discarding Changes	Discards changes made and close the BIOS setup.
Load Setup Defaults	Loads the default settings for all BIOS setup parameters. Setup Defaults are quite demanding in terms of resources consumption. If you are using low-speed memory chips or other kinds of low-performance components and you choose to load these settings, the system might not function properly.
Discard Changes	Discards all changes made in the BIOS setup.
Save Changes	Saves changes made in the BIOS setup.

System Disassembly

This chapter contains step-by-step procedures on how to disassemble the desktop computer for maintenance and troubleshooting.

Disassembly Requirements

To disassemble the computer, you need the following tools:

- Wrist grounding strap and conductive mat for preventing electrostatic discharge
- Flat-blade screwdriver
- Philips screwdriver
- Hex screwdriver
- Plastic flat-blade screwdriver
- Plastic tweezers

NOTE: The screws for the different components vary in size. During the disassembly process, group the screws with the corresponding components to avoid mismatch when putting back the components.

Pre-disassembly Procedure

Before proceeding with the disassembly procedure, perform the steps listed below:

1. Turn off the system and all the peripherals connected to it.
2. Unplug the power cord from the power outlets.
3. Unplug the power cord from the system.
4. Unplug all peripheral cables from the system.
5. Place the system unit on a flat, stable surface.

Main Unit Disassembly

MAIN UNIT DISASSEMBLY

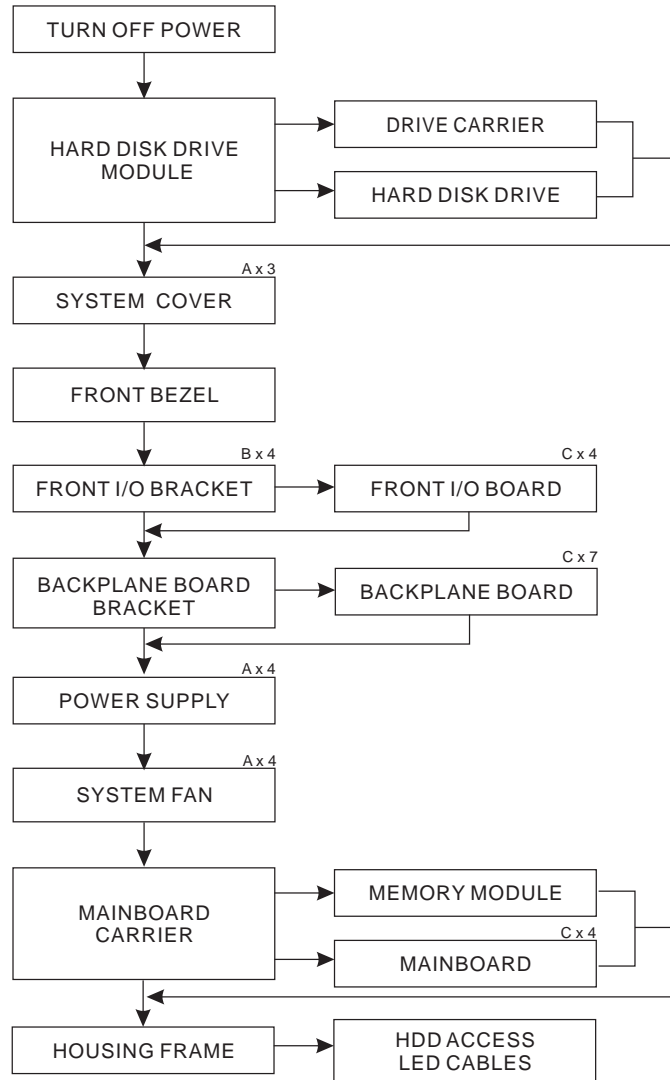

Screw List

	Screw	Part No.
A	M3-0.5*4	86.1A524.4R0
B	M3*6L	86.VA524.6R0
C	M3*0.5*4L	86.19534.4R0

Removing the Hard Disk

- 1. Open the front panel.



- 2. Press to release the hard drive carrier handle.



-
3. Flex the carrier handle.



4. Slide the hard drive carrier out of the HDD bay.



-
5. Remove the carrier by gently prying open the left rail of the carrier (1) and lift the hard disk off the carrier (2) .

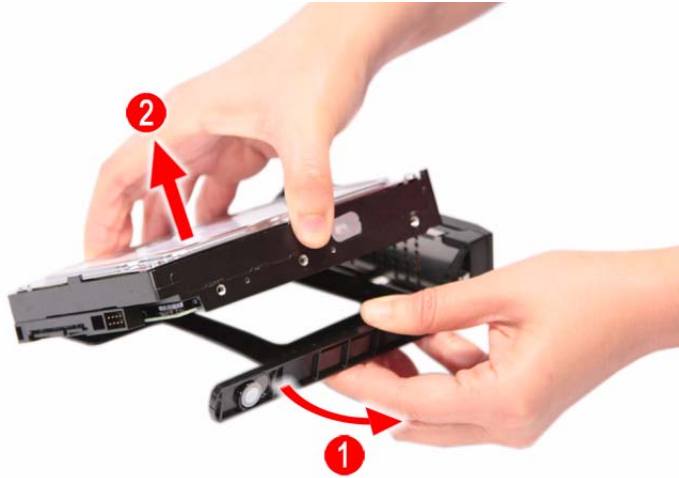

Removing the System Cover

- 1. Perform the pre-disassembly procedure described on page 22.
- 2. Remove the three screws (A) located on the rear panel.



Screw (Quantity)	Color	Torque	Part No.
M3-0.5*4 (3)	Silver	5.1 to 6.9 kgf-cm	86.1A524.4R0

- 3. Slide the system cover toward the back of the chassis until the tabs on the cover disengage with the slots on the chassis.
- 4. Lift the side panel away from the server and put it aside for reinstallation later.

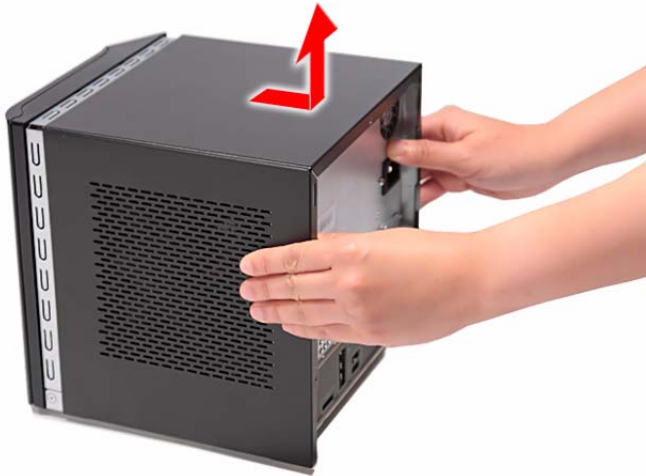

Removing the Front Bezel

- 1. Remove the system cover. Refer to the previous section for instructions.
- 2. Release the front bezel retention tabs from the chassis interior.



- 3. Pull the bezel slightly outward, then disconnect the front I/O board cable.

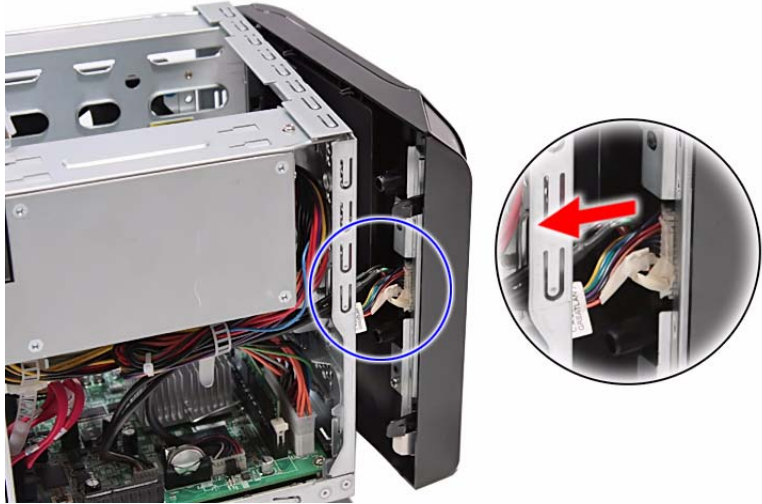

-
4. Pull the bezel away from the chassis.

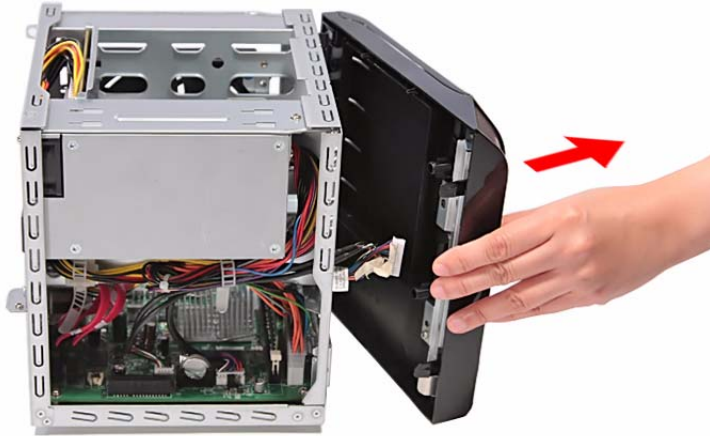

Removing the Front I/O Board

- 1. See "Removing the System Cover" on page 27.
- 2. See "Removing the Front Bezel" on page 28.
- 3. Remove the four screws (B) on the front I/O bracket.

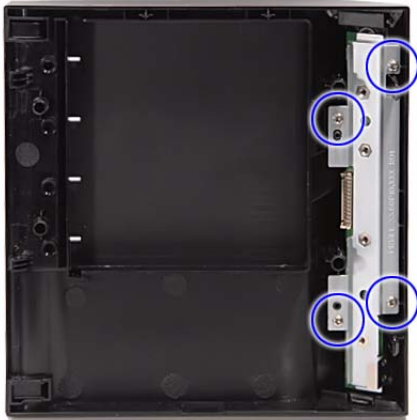

Screw (Quantity)	Color	Torque	Part No.
M3*6L (4)	Silver	5.1 to 6.9 kgf-cm	86.VA524.6R0

- 4. Remove the bracket.



5. Remove the four screws (C) on the front I/O board.



Screw (Quantity)	Color	Torque	Part No.
M3*0.5*4L (4)	Silver	5.1 to 6.9 kgf-cm	86.19534.4R0

6. Remove the front I/O board.

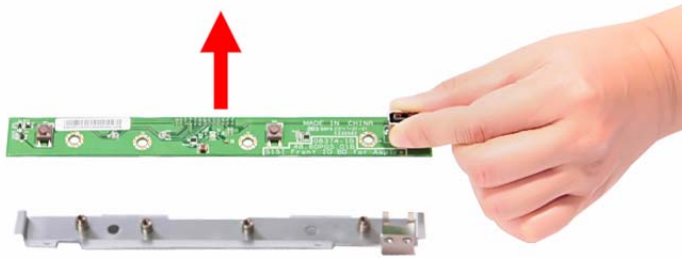

Removing the Backplane Board

1. See “Removing the Hard Disk” on page 24.
2. See “Removing the System Cover” on page 27.
3. Disconnect the fan (1), LED (2), and power (3) cables from the backplane board.

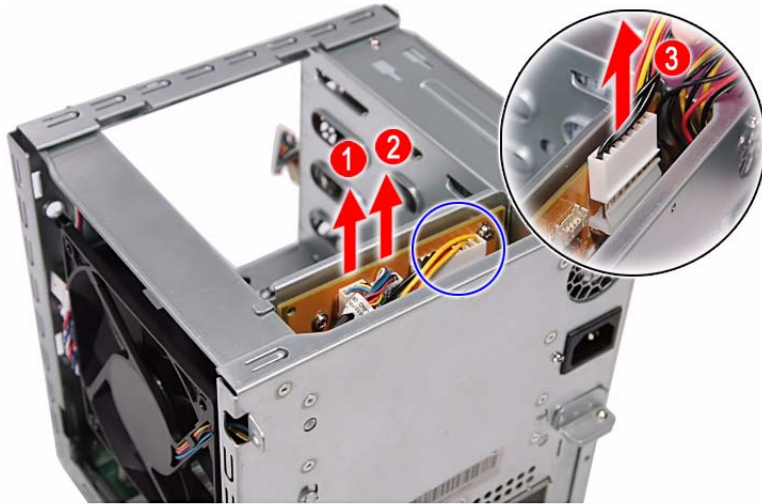

4. Disconnect the four HDD SATA cables from the mainboard.

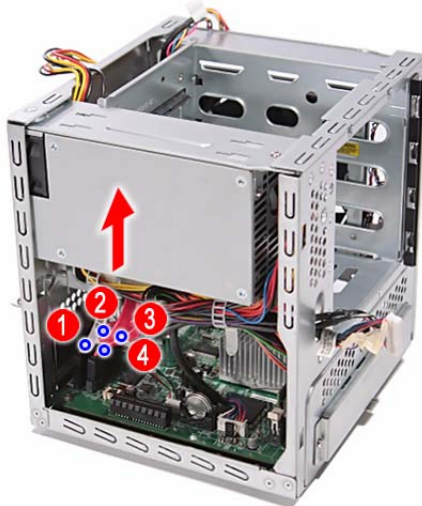

5. Pull the backplane board bracket out of the chassis.



6. Detach the four HDD SATA cables from the backplane board.

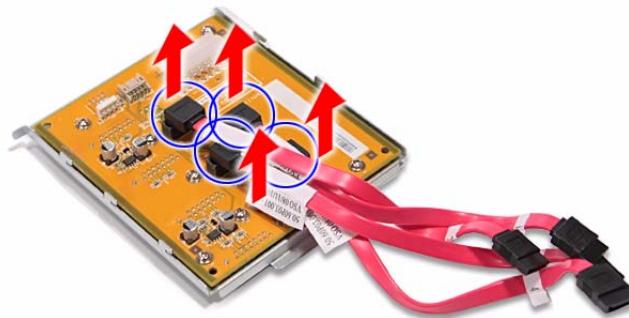

7. Remove the seven screws (C) on the backplane board.

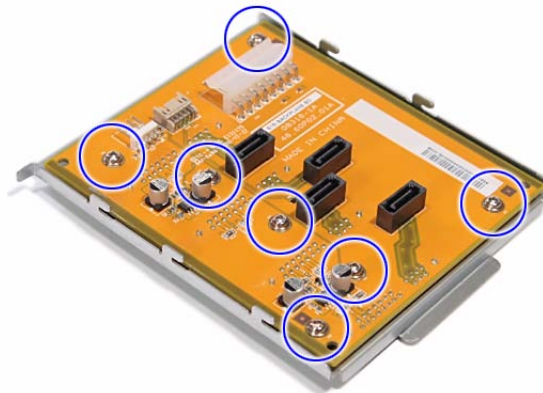

Screw (Quantity)	Color	Torque	Part No.
M3*0.5*4L (7)	Silver	5.1 to 6.9 kgf-cm	86.19534.4R0

8. Remove the backplane board from the bracket.

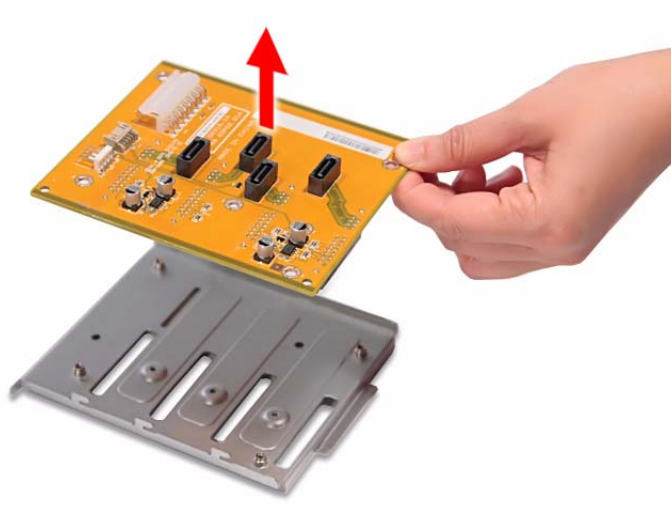

Removing the Power Supply

1. See “Removing the Hard Disk” on page 24.
2. See “Removing the System Cover” on page 27.
3. See “Removing the Backplane Board” on page 32.
4. Release the power cables from the cable ties, as shown.



5. Disconnect the 4-pin power cable from the mainboard.

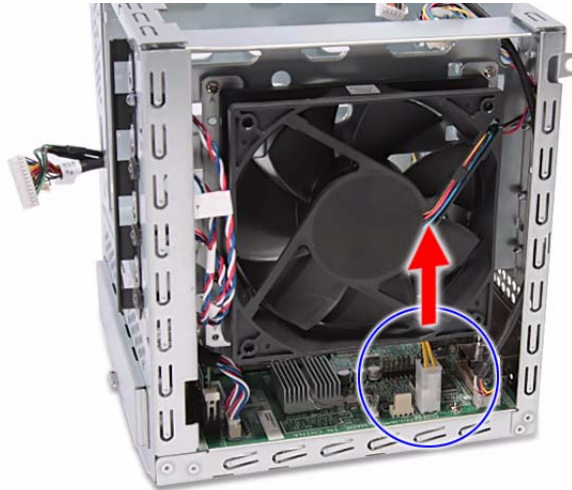

6. Remove the four screws (A) on the power supply.



Screw (Quantity)	Color	Torque	Part No.
M3-0.5*4 (4)	Silver	5.1 to 6.9 kgf-cm	86.1A524.4R0

7. With the thumb in the thumb hole, press the tab to release the mainboard carrier from the chassis.

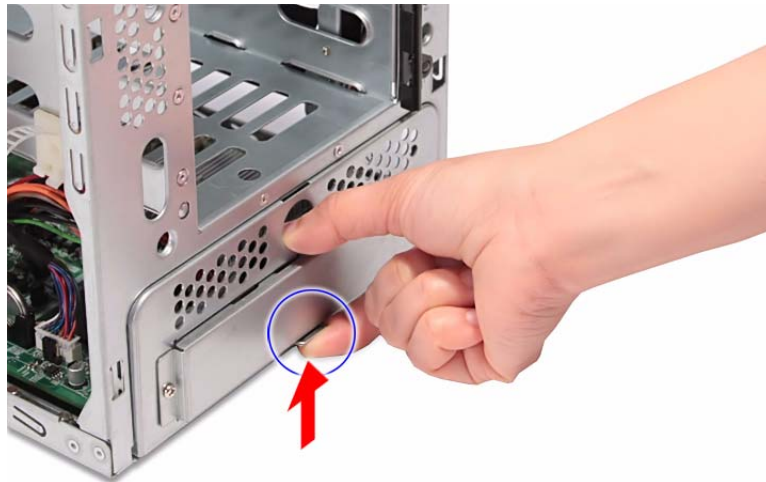

- Slide the mainboard carrier out slightly, until you have access to the power cable.

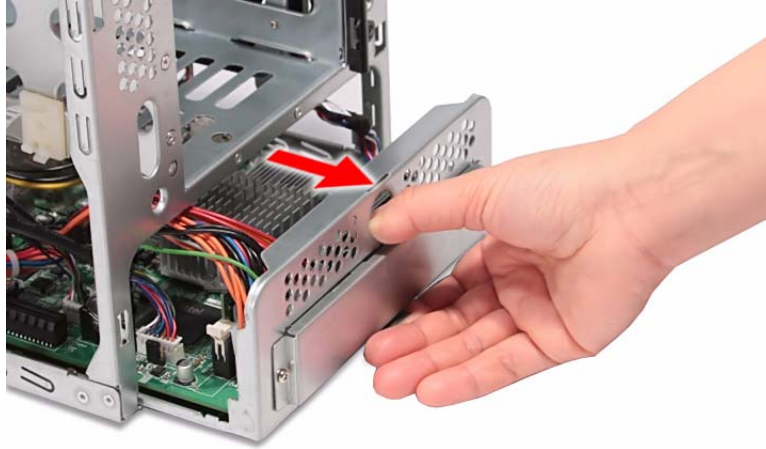

- While pressing the tab on the 24-pin power cable, pull the cable off the connector on the mainboard.

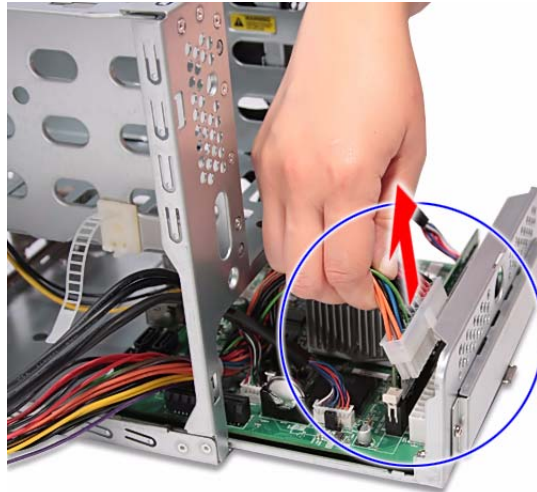

- Pull the power supply out of the chassis.



Removing the System Fan

- 1. See "Removing the Hard Disk" on page 24.
- 2. See "Removing the System Cover" on page 27.
- 3. See "Removing the Backplane Board" on page 32.
- 4. Remove the four screws (A) that secures the system fan to the chassis.



Screw (Quantity)	Color	Torque	Part No.
M3-0.5*4 (3)	Silver	5.1 to 6.9 kgf-cm	86.1A524.4R0

- 5. Remove the system fan.



Removing the Memory Module

1. See “Removing the Hard Disk” on page 24.
2. See “Removing the System Cover” on page 27.
3. See “Removing the Front Bezel” on page 28.
4. See “Removing the Backplane Board” on page 32.
5. See “Removing the Power Supply” on page 35.
6. See “Removing the System Fan” on page 38.
7. Disconnect the HDD access LED cable from the mainboard.



8. Pull the mainboard carrier out of the chassis.



-
9. Press the holding clips on both sides of the DIMM slot outward to release the DIMM (1).
 10. Gently pull the DIMM upward to remove it from the DIMM slot (2).

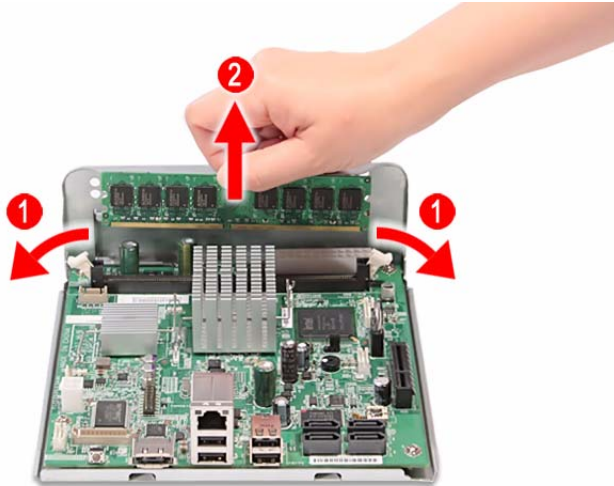

Removing the Mainboard

1. See “Removing the Hard Disk” on page 24.
2. See “Removing the System Cover” on page 27.
3. See “Removing the Front Bezel” on page 28.
4. See “Removing the Backplane Board” on page 32.
5. See “Removing the Power Supply” on page 35.
6. See “Removing the System Fan” on page 38.
7. Remove the four screws (C) that secures the mainboard to the mainboard carrier.



Screw (Quantity)	Color	Torque	Part No.
M3*0.5*4L (4)	Silver	5.1 to 6.9 kgf-cm	86.19534.4R0

8. Remove the mainboard from the mainboard carrier.

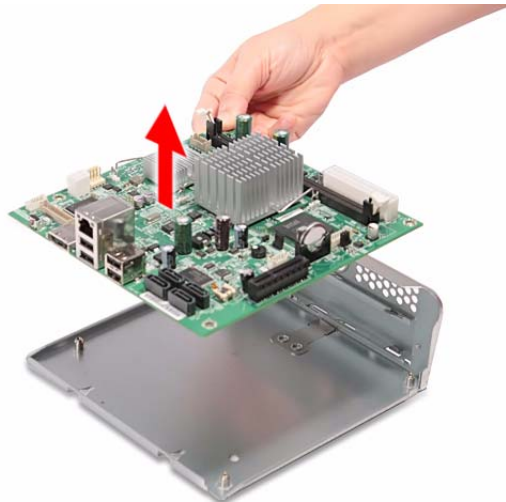

Removing the HDD Access LED cables

1. See “Removing the Hard Disk” on page 24.
2. See “Removing the System Cover” on page 27.
3. See “Removing the Front Bezel” on page 28.
4. See “Removing the Backplane Board” on page 32.
5. See “Removing the Power Supply” on page 35.
6. See “Removing the System Fan” on page 38.
7. See “Removing the Mainboard” on page 41.
8. Press the release tabs on the HDD access LED cables, then detach the cables.

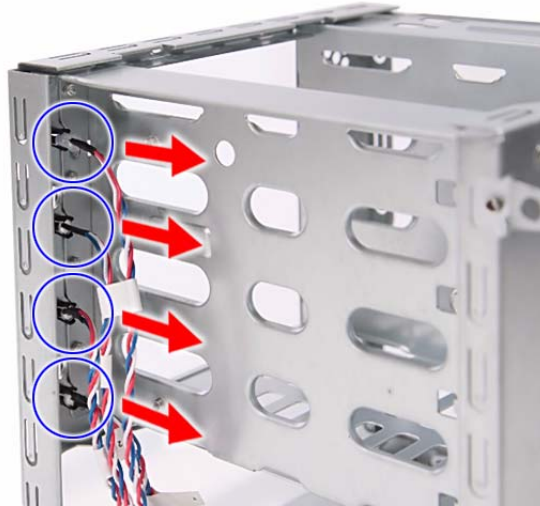

System Troubleshooting

This chapter provides instructions on how to troubleshoot system hardware problems.

Hardware Diagnostic Procedure

IMPORTANT: The diagnostic tests described in this chapter are only intended to test Acer products. Non-Acer products, prototype cards, or modified options can give false errors and invalid system responses.

1. Obtain the failing symptoms in as much detail as possible.
2. Verify the symptoms by attempting to recreate the failure by running the diagnostic tests or repeating the same operation. Refer to the “H340 Diagnostics” on page 44 for more information.
3. Refer to the table below to determine which corrective action to perform.

Problem	Symptom	Section to Refer to
Power failure	The power indicator does not light up or stay lit.	“Power System Check” on page 46
System failure	POST does not complete. No beep or error codes issued.	“Error Codes” on page 47.
	POST detects an error and displayed messages on screen.	

H340 Diagnostics

You can run the H340 diagnostics to determine whether the problems with the system are caused by failing hardware, such as system fan, LED board, hard disk drive, memory, etc. You must prepare a bootable USB device to run the tests on the system.

To run the diagnostics, perform the following steps:

1. Turn off the system.
2. Prepare a bootable USB device by copying or downloading the **ANNIE.GHO** diagnostic utility to the USB device. The diagnostic utility may be obtained from the CD that came with the system.
3. Plug the bootable USB device to any USB port on the rear of the system.
4. Press the Power button to turn on the system. The system status indicator blinks blue.
5. Immediately press and release the Recovery/reset button with the paper clip end. The system status indicator blinks red and immediately starts the diagnostics:
 - a. Onboard memory flash check
 - b. HDD account check
 - c. Memory size check (1024 or 2048 MB)
 - d. Fan speed check
 - e. CPU temperature check
 - f. MB voltage check
 - g. Backplane board temperature check
 - h. PQAF system test
 - i. PQAF memory test
 - j. PQAF HDD test
 - k. Read SN from DMI data check
 - l. End test

During diagnostics, the result of the test displays on the HDD status indicators. The indicators blinks blue when the system has passed each diagnostic test, blinks red when an error condition occurs, and lights purple after the system has completed all diagnostic tests. Refer to the table below for detailed diagnostic conditions.

Test Items	HDD LED status (normal)				HDD LED status (failed)			
	HDD 0	HDD 1	HDD 2	HDD 3	HDD 0	HDD 1	HDD 2	HDD 3
Onboard memory flash check	Blue				Red			
HDD account check		Blue						
Memory size check	Blue	Blue			Red	Red		
Fan speed check			Blue				Red	
CPU temperature check	Blue		Blue		Red		Red	
MB voltage check		Blue	Blue			Red	Red	
Backplane board temperature check	Blue	Blue	Blue		Red	Red	Red	
PQAF system test				Blue				Red
PQAF memory test	Blue			Blue	Red			Red

Test Items	HDD LED status (normal)				HDD LED status (failed)			
	HDD 0	HDD 1	HDD 2	HDD 3	HDD 0	HDD 1	HDD 2	HDD 3
Boot from USB disk		Blue		Blue		Red		Red
Read SN from DMI data check	Blue	Blue		Blue	Red	Red		Red
End test	Purple	Purple	Purple	Purple				

6. After all the tests are completed, the HDD LEDs light purple.
7. A copy of the test result will be saved as a log file (i.e., 66380AC3.LOG) and stored in the Results folder.

System Check Procedures

Power System Check

If the system will power on, skip this section. Refer to System External Inspection.

If the system will not power on, check if the power cable is properly connected to the system and AC source.

System External Inspection

1. Inspect the LED indicators on the front panel, which can indicate the malfunction. For the LED locations and description of their behaviour, see “System LED Indicators” on page 5.
2. Make sure that air flow is not blocked.
3. Make sure nothing in the system is making contact that could short out power.
4. If the problem is not evident, continue with System Internal Inspection.

System Internal Inspection

1. Turn off the system and all the peripherals connected to it.
2. Unplug the power cord from the power outlets.
3. Unplug the power cord from the system.
4. Unplug all peripheral cables from the system.
5. Place the system unit on a flat, stable surface.
6. Remove the system cover. For instructions on removing system cover, refer to “System Disassembly” on page 25.
7. Verify that components are properly seated.
8. Verify that all cable connectors inside the system are firmly and correctly attached to their appropriate connectors.
9. Verify that all components are Acer-qualified and supported.
10. Replace the system cover.
11. Power on the system.
12. If the problem with the system is not evident, you can try viewing the POST messages and BIOS event logs during the system startup.

Error Codes

NOTE: Perform the FRU replacement or actions in the sequence shown in FRU/Action column, if the FRU replacement does not solve the problem, put the original part back in the computer. Do not replace a non-defective FRU.

The error messages in the following table indicate the error signals on the HDD access LED indicators on the front panel and the error symptoms.

Operating condition	HDD LED error codes				Description
	1	2	3	4	
System is booting	■				SATA controller failed
		■			USB controller failed
	■	■			LAN controller failed
			■		System fan failed
	■		■		Memory failed
		■	■		Boot device not found
System has booted	■	■	■	■	Disk failure

Online Support Information

This section describes online technical support services available to help you repair the system.

If you are a distributor, dealer, ASP or TPM, please refer your technical queries to your local Acer branch office. Acer Branch Offices and Regional Business Units may access our website at <http://global.acer.com/support/index>. However some information sources will require a user ID and password. These can be obtained directly from Acer CSD Taiwan.

Acer's Website offers you convenient and valuable support resources whenever you need them.

In the Support & Downloads tab you can download information materials for all of Acer notebook, desktop and server models including:

- Service guides for all models
- User manuals
- Training materials
- BIOS updates
- Software utilities
- Spare parts lists
- Technical Announcement Bulletins (TABs)

For these purposes, we have included an Acrobat File to facilitate a hassle-free downloading of our technical materials.

The following are also available in the Support & Downloads tab:

- Detailed information on Acer's International Traveler's Warranty (ITW)
- Returned material authorization procedures
- An overview of all the support services we offer, accompanied by a list of telephone, fax, and email contacts for all your technical queries.

We are always looking for ways to optimize and improve our services, so if you have any suggestions or comments, please do not hesitate to communicate these to us.

System Block Diagram and Board Layout

System Block Diagram

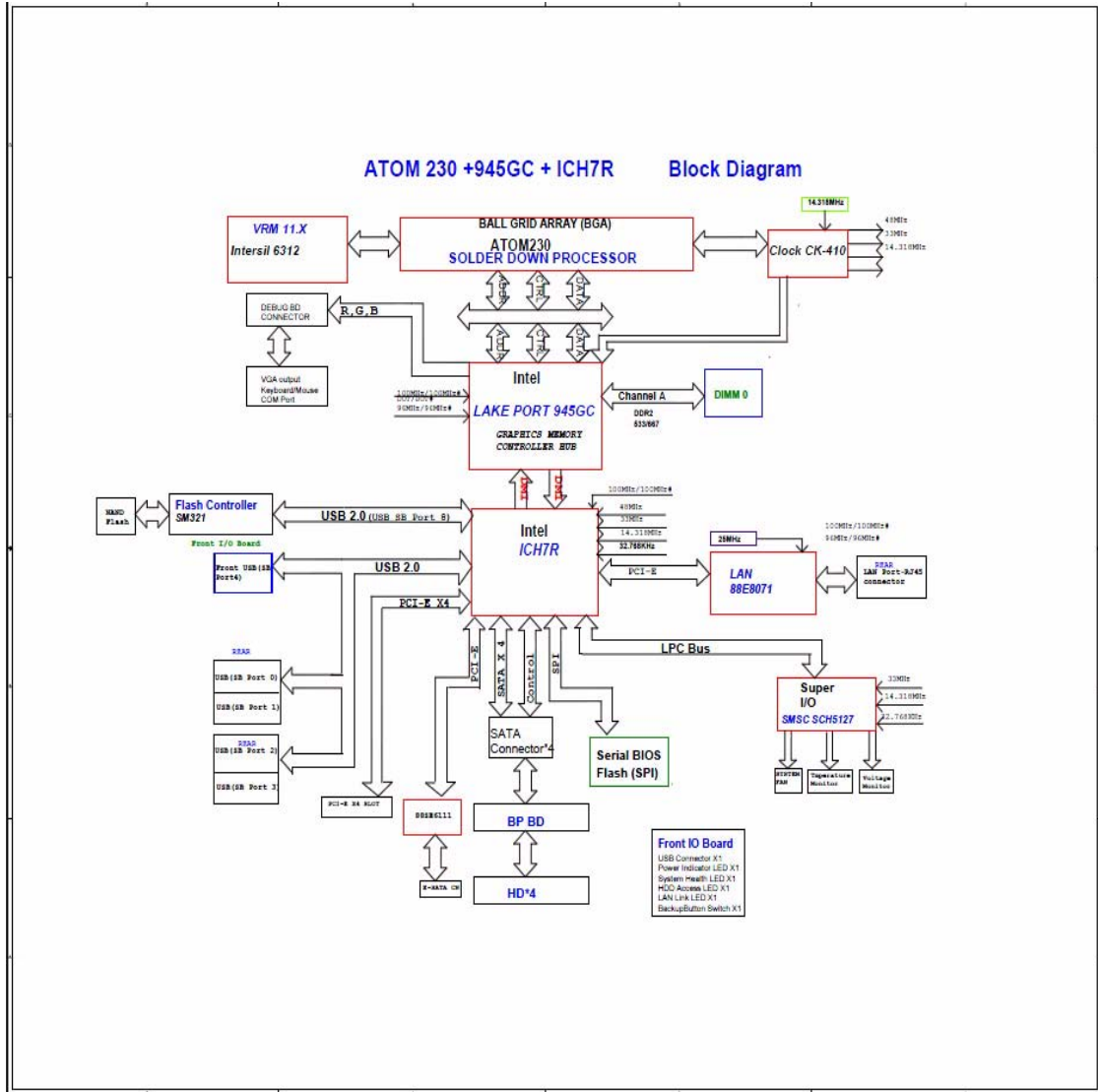

Board Layout

Mainboard

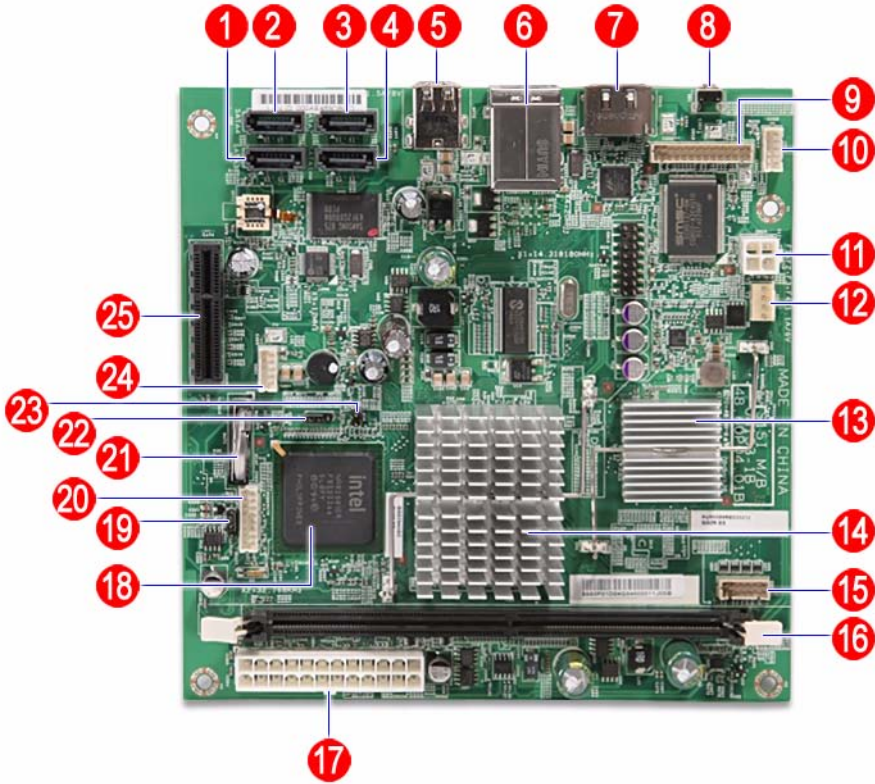

No	Description	No	Description
1	SATA 3 port	14	Intel 945GC chipset (north bridge)
2	SATA 4 port	15	HDD access LED cable connector
3	SATA 2 port	16	DDR2 DIMM slot
4	SATA 1 port	17	24-pin power cable connector
5	USB ports	18	Intel ICH7R chipset (south bridge)
6	Gigabit Ethernet port (top) USB ports (bottom)	19	BIOS recovery jumper
7	eSATA port	20	Front I/O board cable connector
8	Recovery/reset button	21	Battery
9	Debug board connector	22	System type select jumper
10	Backplane board LED cable connector	23	Debug/user mode jumper
11	4-pin power cable connector	24	Front I/O board cable connector
12	System fan cable connector (reserved)	25	x4 PCI Express slot.
13	Processor		

System Jumpers

Name	Location	Settings
BIOS recovery jumper	JP1	1-2 Normal (default) 2-3 Clear CMOS
System type select jumper	JP2	1-2 Aspire system (default) 2-3 Altos system
Debug/user mode jumper	JP3	Open User mode enabled (default) Closed Debug mode enabled

FRU (Field Replaceable Unit) List

This chapter offers the FRU (Field Replaceable Unit) list in global configuration of the home server. Refer to this chapter whenever ordering the parts to repair or for RMA (Return Merchandise Authorization).

NOTES:



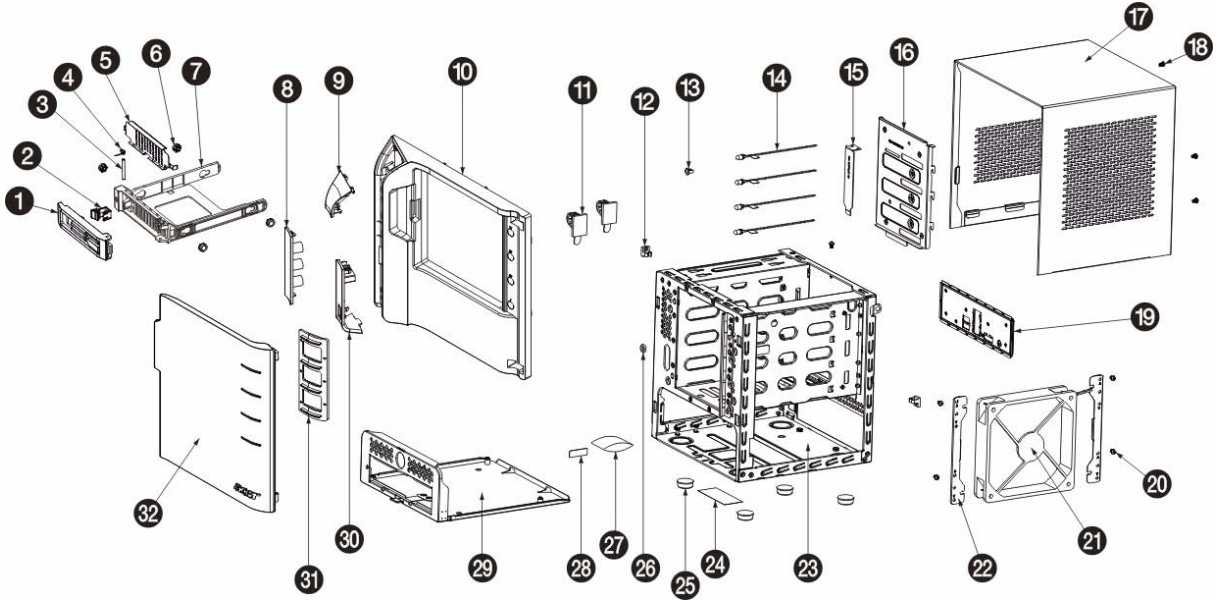

- ❑ When ordering FRU parts, check the most up-to-date information available on your regional web or channel. For whatever reasons a part number is changed, it will NOT be noted on the printed Service Guide. For Acer authorized service providers, your Acer office may have a different part number code from those given in the FRU list of this printed Service Guide. You MUST use the local FRU list provided by your regional Acer office to order FRU parts for service.
- ❑ To scrap or to return the defective parts, follow the local government ordinance or regulations on how to dispose it properly, or follow the rules set by your regional Acer office on how to return it.
- ❑ This document will be updated as more information about the FRU list becomes available.

Exploded Diagram





Item	Part No.	Part Name	QTY.
1	42.60P02.001	Handle HDD carrier HT-361	1
2	42.60P03.001	Latch HDD carrier HT-361	1
3	34.60P07.001	Axis HDD carrier HT-361	1
4	34.60P05.001	SPG HDD carrier HT-361	1
5	34.60P04.001	EMI HDD carrier HT-361	1
6	47.60M06.001	HDD ear rubber pin HT-360	4
7	42.60P01.001	HDD carrier HT-361	1
8	40.60P04.001	PLT as Icon HT-361	1
9	40.60P03.001	PLT as power HT-361	1
10	41.60P02.001	Bezel as main HT-361	1
11	42.55S13.001	Tie mount HU-139	1
12	42.91F07.001	Wire saddle CHF-8 HU122G	2
13	42.5E309.001	LED housing CLED-1A	4
14	50.60P04.001	C.A. HDD LED B/R HT-361	1
15	33.60P09.001	BRKT PCI LP dummy HT-361	1
16	33.60P05.001	BRKT BP HT-361	1
17	30.60P02.001	CAS UP HT-361	1
18	86.1A524.4R0	SCRW MACH PAN M3-0.5*4 NI	4
19	60.60P14.001	ASSY rear I/O cover HT-361	1
20	86.1A524.4R0	SCRW MACH PAN M3-0.5*4 NI	4
21	60.60P11.001	ASSY fan 120x120x25 S15	1
22	33.60P04.001	BRKT fan HT-361	2
23	60.60P02.001	ASSY main chassis HT-361	1
24	45.00049.001	Label spec dummy art UB series	1
25	42.60P11.001	Rubber foot R1907 19D7H	4
26	47.60P05.001	Sponge HDD LED HT-361	4
27	38.09008.001	Dessicant silica gel 30G H25	1
28	40.60P07.001	LBL 24*8MM warning HT-361	2
29	60.60P03.001	ASSY MB tray HT-361	1
30	40.60P06.001	PLT AS USB HT-361	1
31	42.60P17.001	Lens as door HT-361	1
32	42.60P16.001	Door as bezel HT-361	1

FRU List

Component	QTY	Part Name	Description	Acer Part Number
Board				
Front I/O board 	1	FRONT I/O BOARD	S15I ASPIRE FRONT I/O BD DIP	55.R3601.002
Backplane board 	1	BACKPLANE BOARD	S15I BACKPLANE BOARD DIP	55.R3601.001
Cable				
Backplane board cable	1	BACKPLANE BOARD CABLE	C.A. 2CON 10PIN HT361	50.R3601.001
HDD SATA cable	1	HDD SATA CABLE	C.A. HDD SATA CABLE HT-361	50.R3601.003
Front I/O board cable	1	FRONT I/O BOARD CABLE	C.A. 2CON 26PIN HT361	50.R3601.002
HDD access LED cable		HDD LED CABLE	C.A. HDD LED B/R HT-361	50.R3601.004
Power cord	1	POWER CORD 2.5A 250V 1800MM BLACK UK SING	CORD AC UK/SING 2.5A250V 1800	27.R3601.003
	2	POWER CORD 1800MM BLACK EUR	CORD PWR AC LINE EUR 1.8M BLK	27.R3601.002
		POWER CORD 7A 125V 1800MM BLACK US	CORD SVT 10A 125V 1800MM BLK	27.R3601.001
		POWER CORD 7A 125V JAPAN	CORD VCTF 3G 7A/125V(JAPAN)	27.01518.181
		POWER CORD 250V 10A 1800MM SWISS	CORD 250V 10A 1800MM SWISS	27.01518.251
		EXTERNAL ETHERNET CAT5E CABLE BLACK 2M	C.A. CAT5E STRAI BLACK_2M BIZ	50.R3601.005
Case/Cover/Bracket Assembly				
Front I/O dummy bracket	1	FRONT I/O DUMMY BRACKET	BRKT FRONT I/O HT-361	33.R3601.003
Power supply support bracket	1	POWER SUPPLY SUPPORT BRACKET	BRKT PSU SUPPORT HT-361	33.R3601.002
Front bezel 	1	FRONT BEZEL W/KEY LOCK&KEY	ASSY ASPIRE BEZEL HT-361	60.R3601.002
Housing frame 	2	ASSEMBLY CHASSIS W/HDD LED CABLE&FAN&UPPER CASE&LOWER CASE&HDD BRACKET&MAIN BOARD CARRIRE&FAN BRACKET	HOUSING ASSY HT-361	60.R3601.001

Component	QTY	Part Name	Description	Acer Part Number
Front I/O bracket 		FRONT I/O BOARD BRACKET	ASSY BRKT AS FRONT I/O HT-361	33.R3601.001
HDD carrier 		HDD CARRIER	ASSY HDD CARRIER HT-361	42.R3601.001
Backplane bracket 		Backplane bracket	BRKT BP HT361	N/A
Mainboard carrier 		Mainboard carrier	ASSY MB TRAY HT-361	N/A
System cover 		System cover	CAS UP HT-361	N/A
Key		MASTER KEY	DK103-KY05 MASTER KEY HT-361	33.R3601.004
Fan				
		FAN W/FAN RUBBER	ASSY FAN 120X120X25 S15	23.R3601.001
Hard disk drive				
	1	HDD SEAGATE 3.5" 7200RPM 1000GB ST31000333AS BRINKS SATA II LF F/W:SD45	HDD 1TB SGT ST31000333AS 7.2KR	KH.01K01.005
	1	HDD SEAGATE 3.5" 7200RPM 640GB ST3640623AS BRINKS SATA II 16MB LF F/W:SD43	HDD 640GB 3.5" SGT ST3640623AS	KH.64001.001
Mainboard				
	1	MAINBOARD S15I INTEL 945GC ICH7R V1.0 LF FOR ASPIRE/ ALTOS ESAYSTORE W/ CPU&HEATSINK	S15I MAIN BOARD W/O CPU,DIMM D	MB.R3601.001

Component	QTY	Part Name	Description	Acer Part Number
Memory				
	1	MEMORY UNIFOSA UNB-DIMM DDRII 800 1GB GU341G0ALEPR6B2C6CE LF	DIMM 1G GU341G0ALEPR6B2C6CE	KN.51203.034
	1	MEMORY UNIFOSA UNB-DIMM DDRII 800MHZ 1GB GU341G0ALEPR6B2C6CE LF	DIMM 1G GU341G0ALEPR6B2C6CE	KN.1GB0H.009
Power supply				
	1	PSU DELTA GPS-200AB B 200W 100-240V S1	SPS 200W 1U DELTA GPS-200AB B	PY.20009.001
Screws				
	1	SCRW TAP PAN M3*6L 2LEAD NI	SCRW TAP PAN M3*6L 2LEAD NI	86.VA524.6R0
	1	SCRW MACH P/WS M3*0.5*4L NI	SCRW MACH P/WS M3*0.5*4L NI	86.19534.4R0
	1	SCRW MACH PAN M3-0.5*4 NI	SCRW MACH PAN M3-0.5*4 NI	86.1A524.4R0

Technical Specifications

This section provides technical specifications for the system.

Processor

Item	Specification
Type	Onboard Intel Atom 200 series
Model number	Atom 230
Frequency (MHz)	1600
L2 cache size (KB)	512
Socket type	Micro-FCBGA
Stepping	F3
Manufacturing tech (CMOS)	90 nm SOI
Wattage (W)	4
System bus (MHz)	533

System Board Major Chips

Item	Specification
System core logic	Intel 945GC + Intel ICH7R
Storage controller	Intel ICH7R
Graphics memory controller	Intel 945GC
Flash disk controller	Intel ICH7R + SM321
LAN controller	Intel ICH7R + Marvell Yukon 88E8071
Hardware sensors monitor	Intel ICH7R + SMSC SCH5127 Super I/O

System Memory

Item	Specification
Memory type	DDR2-800 unbuffered DIMM
Organization	Unbuffered, non-ECC
Pin count	240
DIMM sockets	1
DIMM size	1 GB or 2 GB
Minimum memory	1 GB
Maximum memory	2 GB
Vendor	Unifosa
Model name	GU341G0ALEPR6B2C6CE GU342G0ALEPR692C6CE

System BIOS

Item	Specification
BIOS vendor	Pheonix
BIOS version	N/A
Flash memory	256 MB

PCI Interface

Item	Specification
PCI Express controller	Intel ICH7R
Number of slots	One PCI Express x 4 slot

Network Interface

Item	Specification
LAN controller	Intel ICH7R + Marvell Yukon 88E8071
Supports LAN protocol	10/100/1000 Mbps
LAN connector type	RJ45

SATA Interface

Item	Specification
SATA controller	SATA: Intel ICH7R eSATA: Intel ICH7R + Marvell 88SE6111
Connectors	<ul style="list-style-type: none">• Four SATA ports• One eSATA port (optional)