

FURUNO

INSTALLATION MANUAL

COLOR RADAR

MODEL FCR-904



FURUNO ELECTRIC CO., LTD.
NISHINOMIYA, JAPAN

C O N T E N T S
* * * * *

	<u>Page</u>
EQUIPMENT LIST/OPTIONAL SUPPLY/ACCESSORIES/SPARE PARTS	0-1
INSTALLATION MATERIALS	0-2
CHAPTER 1 INSTALLATION INSTRUCTIONS	1-1 to 1-15
1.1 General	1-1
1.2 Scanner Unit Installation	1-1
Scanner Unit Siting Considerations	1-1
Scanner Unit Mounting	1-2
1.3 Display Unit Installation	1-6
1.4 Rectifier Unit Installation (Option)	1-9
1.5 Connections	1-11
Connections to Display Unit	1-11
Scanner Unit Internal Wiring	1-11
Connections to Scanner Unit	1-12
Connections to Rectifier Unit (Option)	1-14
CHAPTER 2 ADJUSTMENT AT INSTALLATION	2-1 to 2-7
Tuning & Tuning Indicator Sensitivity	2-1
Sweep Timing	2-3
Heading Alignment	2-4
Magnetron Heater Voltage (Confirmation only)	2-5
Gain Preset	2-6
Sea Clutter	2-6
Rain Clutter	2-6
Main Bang Suppression (MBS)	2-7
APPENDIX 1 CHANGING THE SPECIFICATIONS BY AN INTERNAL DIP SWITCH	AP1-1
APPENDIX 2 ALTERATION OF POWER SUPPLY	AP2-1

EQUIPMENT LIST

No.	Name	Type	Weight (kg)	Q'ty
1	Scanner Unit	RSB-0024	23	1
2	Display Unit	RDP-050	12	1
3	Accessories	FP03-02100		1 set
4	Standard Spare Parts	SPO3-02800		1 set
5	Installation Materials			1 set

OPTIONAL SUPPLY

No.	Name	Type	Weight (kg)	Q'ty	Remarks
1	Rectifier	RU-3423	16.5	1	AC mains only
2	Power Cable	VV-S 2.0x2C		1	Cable length:5m
3	External Buzzer	OP03-21		1	For alarm
4	Vinyl Cover	03-019-0401		1	Code No. 008-280-560

ACCESSORIES (Type: FP03-02100, Code No.: 000-081-102)

No.	Name	Type	Code No.	Q'ty
1	Hood Assy.	FP03-02110	008-280-550	1

STANDARD SPARE PARTS (Type: SPO3-02800, Code No.: 000-081-103)

No.	Name	Type	Code No.	Q'ty
1	Fuse	FGBO 15A AC125V	000-549-014	2
2	Fuse	FGBO 1A AC125V	000-549-061	2
3	Fuse	FGBO 10A AC125V	000-549-065	2
4	Hex. Wrench	Diagonal: 1.5mm	000-830-112	1
5	Carbon Brush	For RM-3622	000-430-890	2
6	L-handle Socket Wrench	For M8 hex. bolt	000-830-110	1
7	Spare Parts Box	For F710	000-831-610	1

CHAPTER 1 INSTALLATION INSTRUCTIONS

INSTALLATION MATERIALS

For Display Unit

No.	Name	Type	Code No.	Q'ty	Remarks
1	Connector	16P2B	000-500-346	1	For power cable
2	Signal Cable Assy.	S03-11-10 (10m)	008-204-690	1	To be selected (With connector at display end)
		S03-11-15 (15m)	008-204-700		
		S03-11-20 (20m)	008-204-710		
		S03-11-30 (30m)	008-204-720		

For Scanner Unit

No.	Name	Type	Code No.	Q'ty
1	Connector	CN-7042	000-510-580	1
2	Lug	∅4	000-536-100	4
3	Crimp-on Lug	FV5.5-S3	000-538-120	1
4	Crimp-on Lug	FV1.25-3 RED	000-538-113	22
5	Seal Washer	CW1053DX	000-850-021	4
6	Hex. Bolt	M12x60 SUS304	000-862-191	4
7	Hex. Nut	M12 SUS304	000-863-112	4
8	Flat Washer	M12 SUS304	000-864-132	4
9	Spring Washer	M12 SUS304	000-864-263	4
10	Slotted Pin G-type	10x45 SUS	000-866-390	2
11	Drain Tube	03-003-3001-0	300-330-010	1
12	Hex. Bolt	M8x30 SUS304	000-862-187	4
13	Flat Washer	M8 SUS304	000-864-130	4
14	Spring Washer	M8 SUS304	000-864-262	4
15	O-ring	JISB2401-1A-G80	000-851-313	1
16	Adhesive	#1211 (50g)	000-854-118	1

Assembly from No.1 to No.11 --- Type: CP03-02801, Code No.: 008-206-960

1.1 General

This radar system is mainly composed of two units; the display unit and the scanner unit, and operates directly from 12/24/32VDC. For the operation from 100/110/115/220/240VAC ship's mains, the rectifier unit (RU-3423) is additionally used. When the radar is first unpacked, check that all necessary units, parts and materials are contained. Refer to the equipment, installation materials and spare parts lists. The steel and wood works should be arranged locally.

1.2 Scanner Unit Installation

Siting Considerations

The scanner unit is generally installed either on top of the wheelhouse or on an appropriate platform on the radar mast. When siting the unit, consider the following points.

- 1) The standard supply interconnecting cable run between the scanner and the display is 10m long. If additional cable is required for a particular installation an unbroken length must be used (i.e., no splices allowed!), and the maximum length is 30 meters.
- 2) Any large metallic objects such as funnels, masts or derrick posts around the radar scanner may well block its line of sight, causing blind sectors in the radar picture. The sector directly ahead is obviously most important to the radar operator, so carefully plan the site of the scanner so the forward area is clear of obstructions.
- 3) Deposits and fumes from a funnel or other exhaust vent can adversely affect the aerial performance and hot gases tend to distort the radiator portion. The scanner unit must not be mounted in a location where it may be subjected to temperatures in excess of 70°C.
- 4) The compass safe distance, 3.35 meters, standard compass; and 2.20 meters, steering compass, should be observed.
- 5) The unit must not be located in close proximity to a radio direction finder antenna, since the DF would be adversely affected. A separation of more than 2 meters is recommended.

Mounting and Connecting the Scanner Unit

The following cautions should be noted before beginning work on the scanner unit.

- 1) As the scanner base is made of cast aluminum, the mounting platform must be painted if it is made of iron, otherwise the scanner might be damaged due to electrolytic corrosion.
- 2) Apply silicone sealant to bolts, nuts and washers to make future removal easier.
- 3) Do not paint the radiator aperture.
- 4) Do not lift the scanner unit by the radiator.

Fixing the Scanner to the Chosen Site

1. Drill four bolt holes (13mm dia.), one cable entry hole (approx. 50mm dia.) and one drain hole (15mm dia.) in the radar mast or platform or the deck. See the scanner outline drawing on the next page.
2. Detach the scanner housing cover from the scanner housing after loosening the four fixing bolts. Store the scanner housing cover fitted with the transceiver module in a convenient place until the wirings to the scanner unit are completed.
3. Place the scanner housing on the chosen site, and orientate it as shown in Fig.1-1.

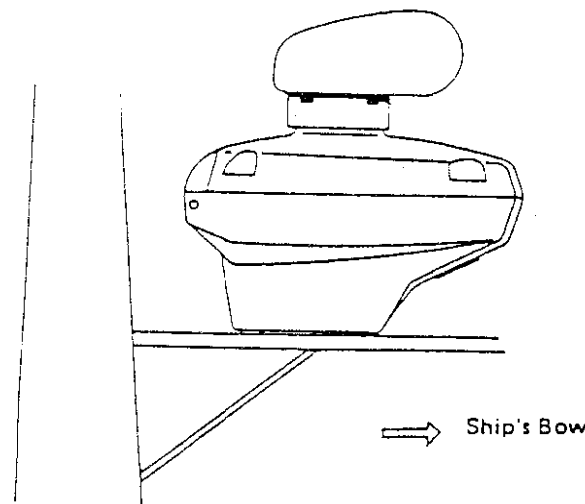

Fig.1-1 Orientating the Scanner Housing

4. Apply silicone sealant to the M12x60 hex. bolts, seal washers, nuts and washers before using them to secure the scanner housing. The bolts must be inserted with their heads facing upward (from inside the scanner housing) so that they do not touch the transceiver module.

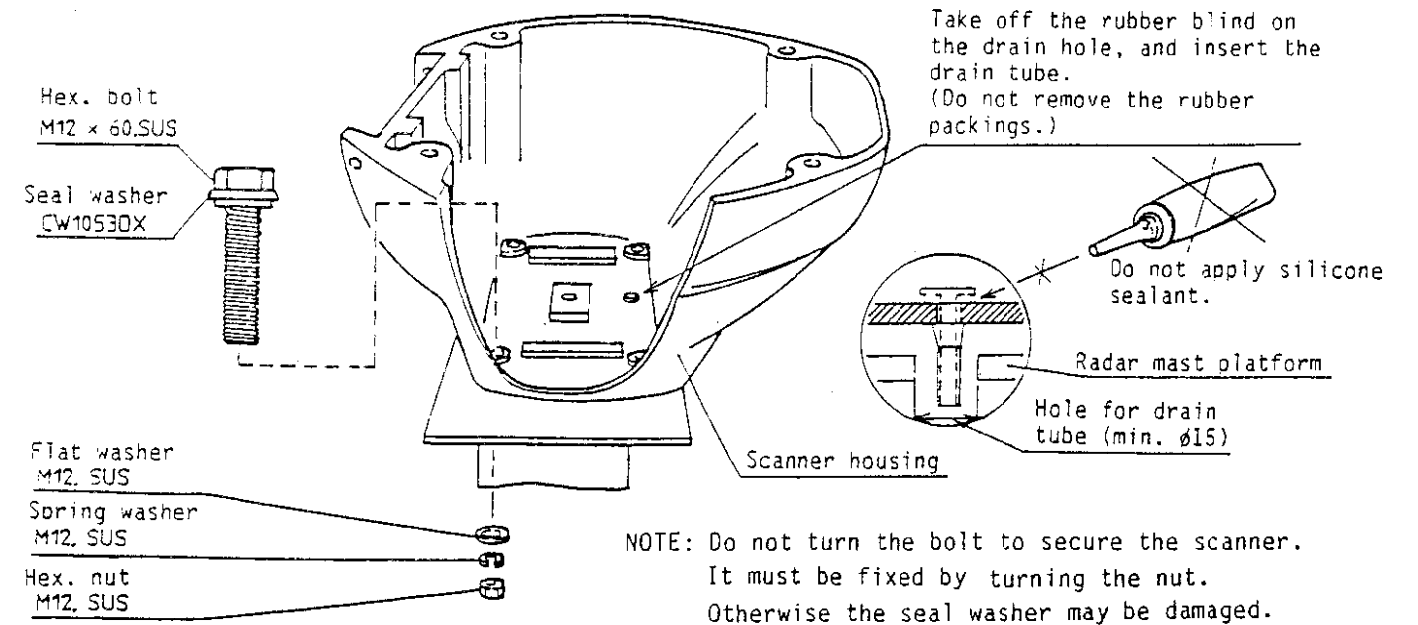

Fig.1-2 Mounting of Scanner Hosing

To complete the scanner hosing mounting, making wiring to the scanner unit referring to "Connection to Scanner Unit" on page 1-12. Then proceed to the following steps.

5. Place the scanner housing cover onto the scanner housing after removing the transceiver module. Apply grease to the O-ring. Making sure the O-ring is seated in the groove, fasten the four fixing bolts temporarily by hand.

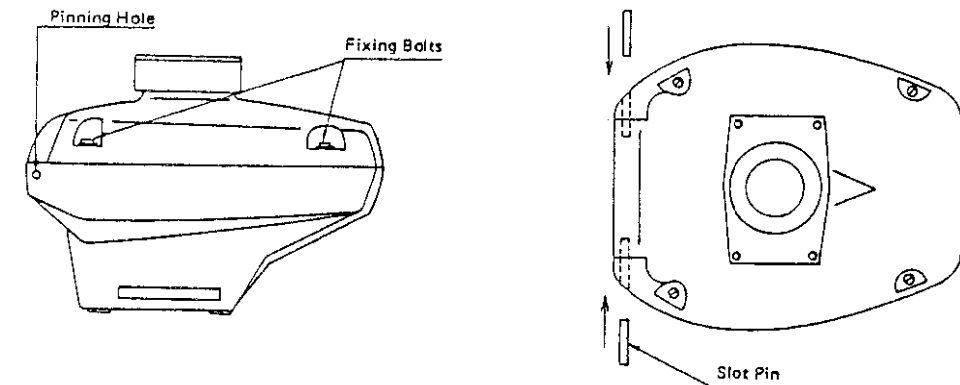
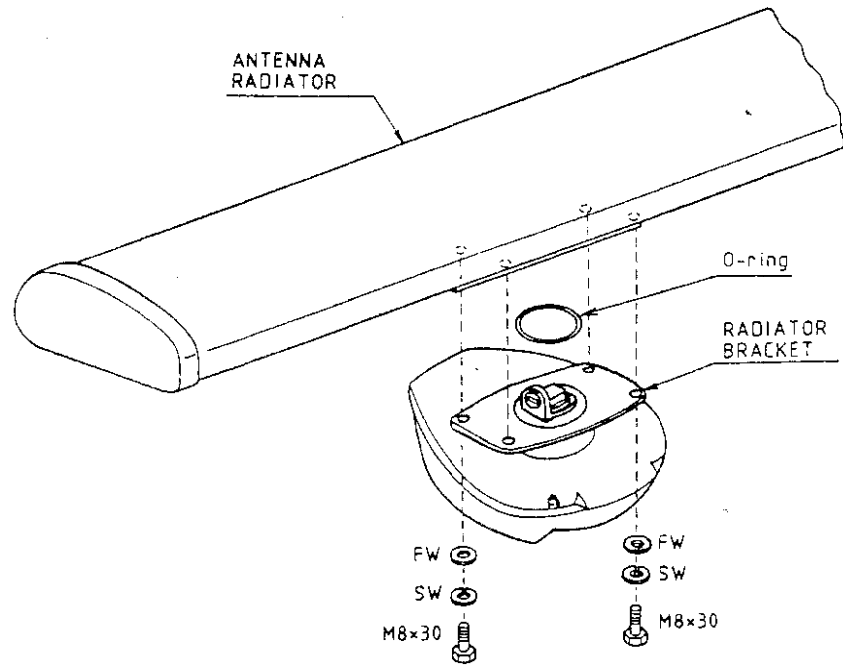

Fig.1-3 Assembling the Scanner Housing

6. Apply grease to the two slot pins and insert them into the pinning holes, shown in Fig.1-3, until the pin head becomes flush with the scanner housing surface. It is recommended to use a wooden hammer to avoid damaging the cosmetic paint.

7. Mount the radiator as shown in Fig.1-4. Silicone sealant should be applied to the bolts and nuts before assembling.



At the bottom of the antenna radiator, apply anticorrosion silicone sealant to the groove and the hatched area shown in the illustration below. Failure to do so will result in corrosion of the mating surface in about one year.

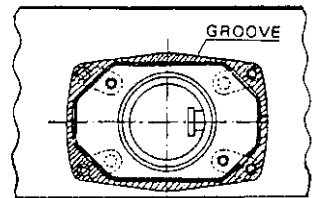

ANTENNA RADIATOR BOTTOM VIEW

Fig.1-4 Mounting the Antenna Radiator

8. Open the scanner housing cover and support it with the stay.
9. Mount the transceiver module onto the scanner housing cover.
10. Make the scanner unit internal wirings referring to the "Scanner Unit Internal Wiring" on page 1-11.

NOTE 1. 整備時に取付け、パイプ真下の空中線部取付け台にφ15以上の穴を開けよ。
 FITTED AT INSTALLATION. HOLE (MIN φ15) TO BE MADE ON MOUNTING PEDESTAL UNDER THE TUBE.

MODEL 1940
 FR-7040D/7100D
 FCR-903/904
 FR-603D/604D/8030D

品番 ITEM	品名 NAME	材質 MATERIAL	数量 Q'TY	図番 DWG. NO.	備考 REMARKS
承認 APPROVED	FEB. 2. '89 T. NAKANO	三角法 THIRD ANGLE PROJECTION	名称 TITLE	レ-ダ-空中線部寸法図 RADAR SCANNER UNIT	
検 CHECKED	FEB. 2. '89 I. Amano	尺度 SCALE	1/8		
製 DRAWN	FEB. 2. '86 Y. Tomiyama	重量 WEIGHT	23 (XN12A) 25 (XN13A) kg		

REV. : 3/85

FURUNO ELECTRIC CO., LTD.

1.3 Display Unit Installation

Locate the Display Unit in a position where it can be viewed and operated conveniently but where there is no danger of salt or fresh water spray or immersion.

Compass Safe Distance; The magnetic compass may be affected if the Display Unit is placed too close, because of fields generated in the radar. The compass safe distance (approx. 1.5m for standard compass and approx. 1.1m for steering compass) must not be disregarded.

The orientation of the Display Unit should be so that the radar screen is viewed while the operator is facing in the direction of the bow. This makes determination of your position much easier.

As supplied, the display unit is provided for tabletop mounting, but it can be easily converted for bulkhead/overhead mounting. See the next page.

Mount the display unit as follows:

- 1) Remove the mounting cradle from the display main body by undoing two bolts at the front bottom of the display unit. See Fig.1-5.
- 2) Drill four bolt holes of 12mm dia. through the tabletop to correspond to the fixing holes on the mounting cradle.
- 3) Secure the mounting cradle on the table by using M10 bolts, nuts and washers or coach screws and washers.
- 4) Place the display main body on the mounting cradle and secure it with the two bolts at the front bottom.

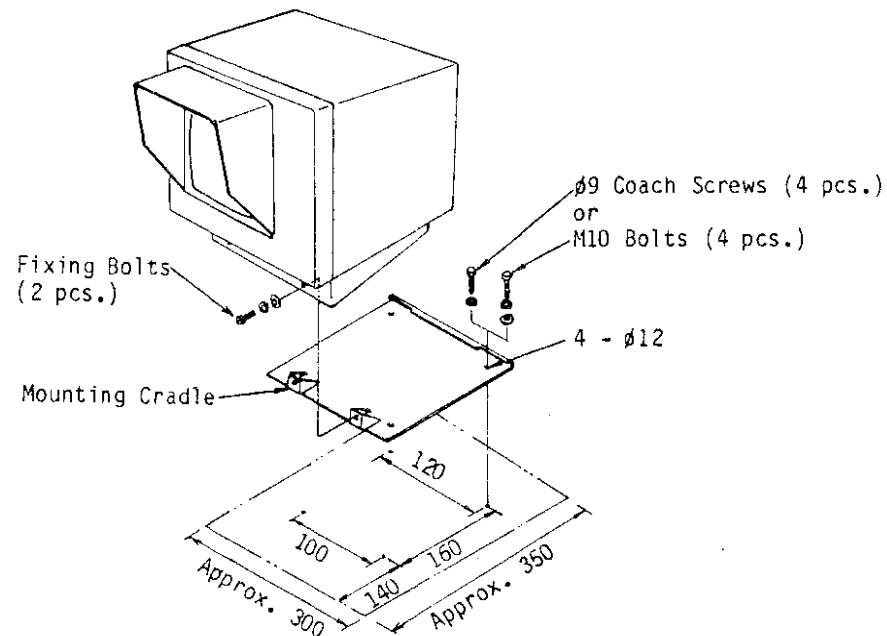

Fig.1-5 Display Unit Mounting

Conversion from Tabletop Mount to Bulkhead/Overhead Mount

The tabletop mount type display can be converted to the bulkhead or overhead mount type by the following method.

1. Take off the top cover by loosening the four cosmetic screws.
2. Loosen the two M8 x 40 hex. bolts and remove the mounting cradle from the ramp base.
3. Remove the ramp base and bottom plate from the display main body by loosening the four M5 x 12 hex. bolts and the four M4 x 8 screws, respectively. See Fig.1-6.
4. Secure the bottom plate and ramp base removed in step 3 on the top of the display main body.
5. Fix the top cover on the bottom of the display main body.
6. To install the unit, secure the mounting cradle on the bulkhead or ceiling before assembling it with the ramp base.

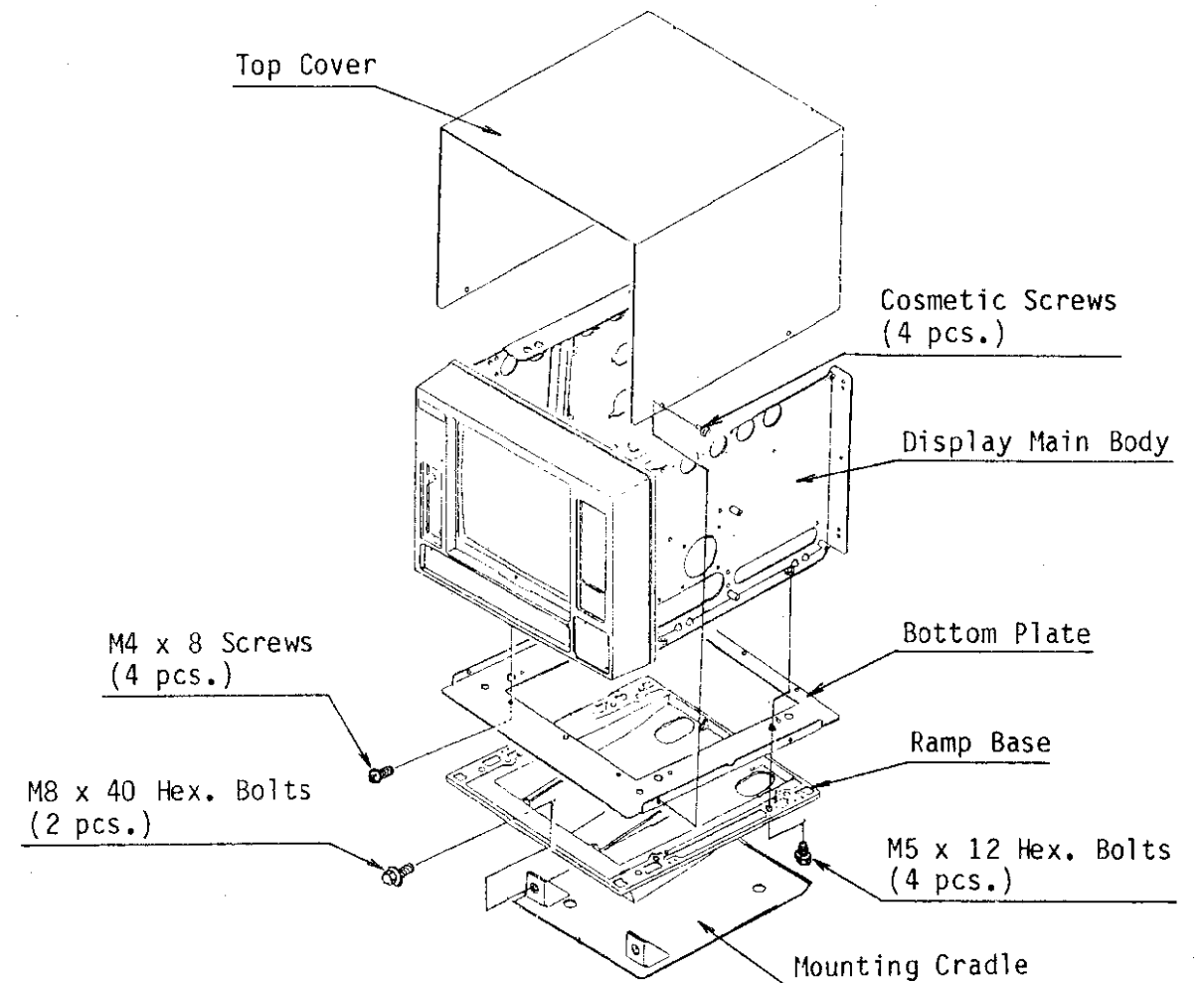
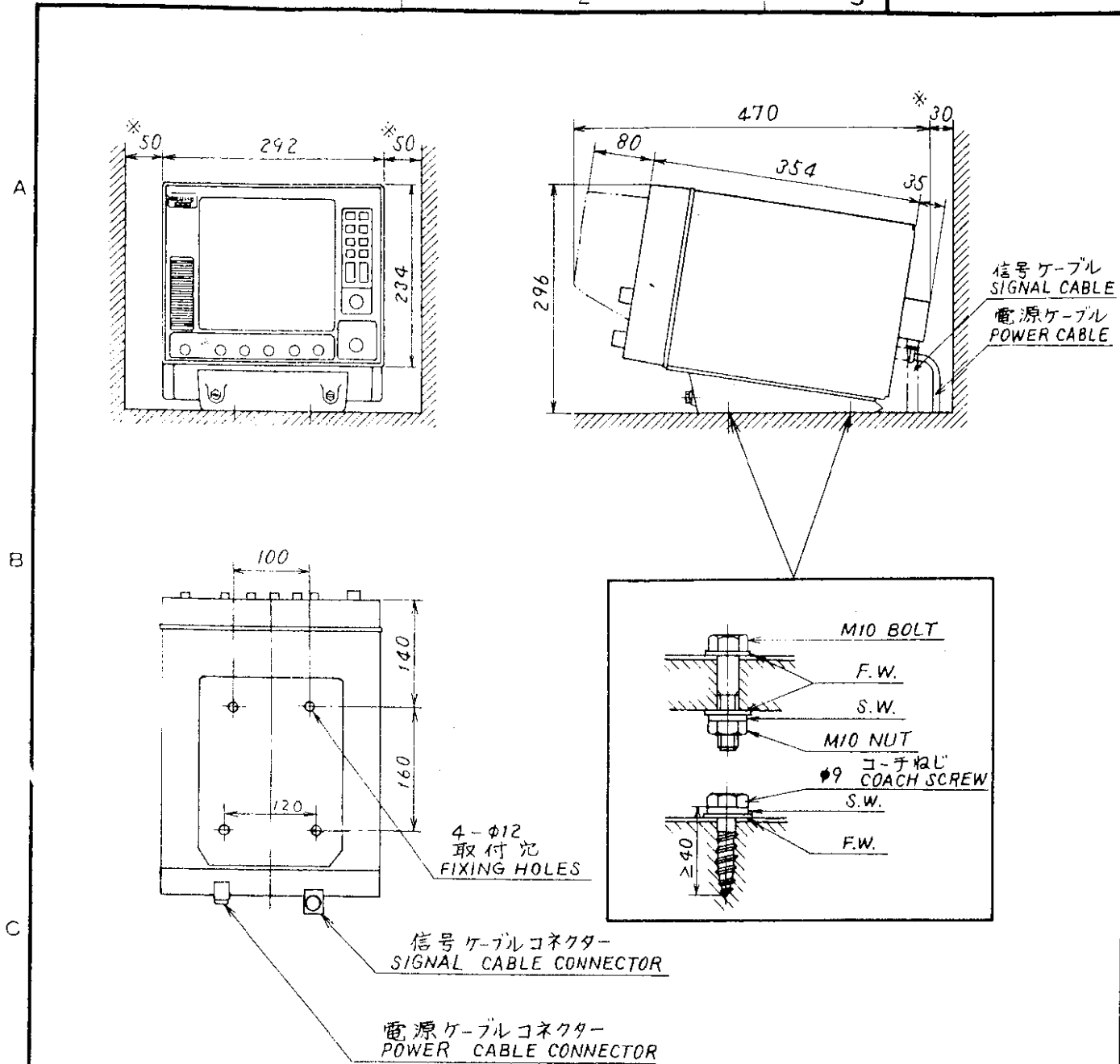

Fig.1-6



NOTE 1. ※ : 推奨サービス空間.
RECOMMENDED SERVICING CLEARANCE.

NOTE 2. 装備ケーブルはサービス時、指示部を前方に十分引き出せるよう余裕をもたせること。
SUFFICIENT EXTRA CABLINGS SHOULD BE ALLOWED AT THE BACK OF THE UNIT SO THAT THE UNIT CAN BE DRAWN OUT WITH THE CABLES CONNECTED FOR MAINTENANCE.

1.4 Rectifier Unit Installation (Option)

For the set driven by 100/110/115/220/240VAC ship's mains, a rectifier unit is required. The unit can be mounted in any dry, well ventilated place. The mounting dimensions are shown in the rectifier outline drawing on page 1-10. The compass safe distance of 2.1m standard and 1.5m steering should be observed.

FCR-900 SERIES		品番 ITEM	品名 NAME	材質 MATERIAL	数量 Q'TY	図番 DWG. NO.	摘要 REMARKS
承認 APPROVED	June 26 '86		三角法 THIRD ANGLE PROJECTION	名称 TITLE			レーダー指示部外寸図 RADAR DISPLAY UNIT
検図 CHECKED	June 26 '86	尺度 SCALE	1/8				
製図 DRAWN	June 26 '86	重量 WEIGHT	12 kg	図番 DWG. NO.		C3293-010-A	

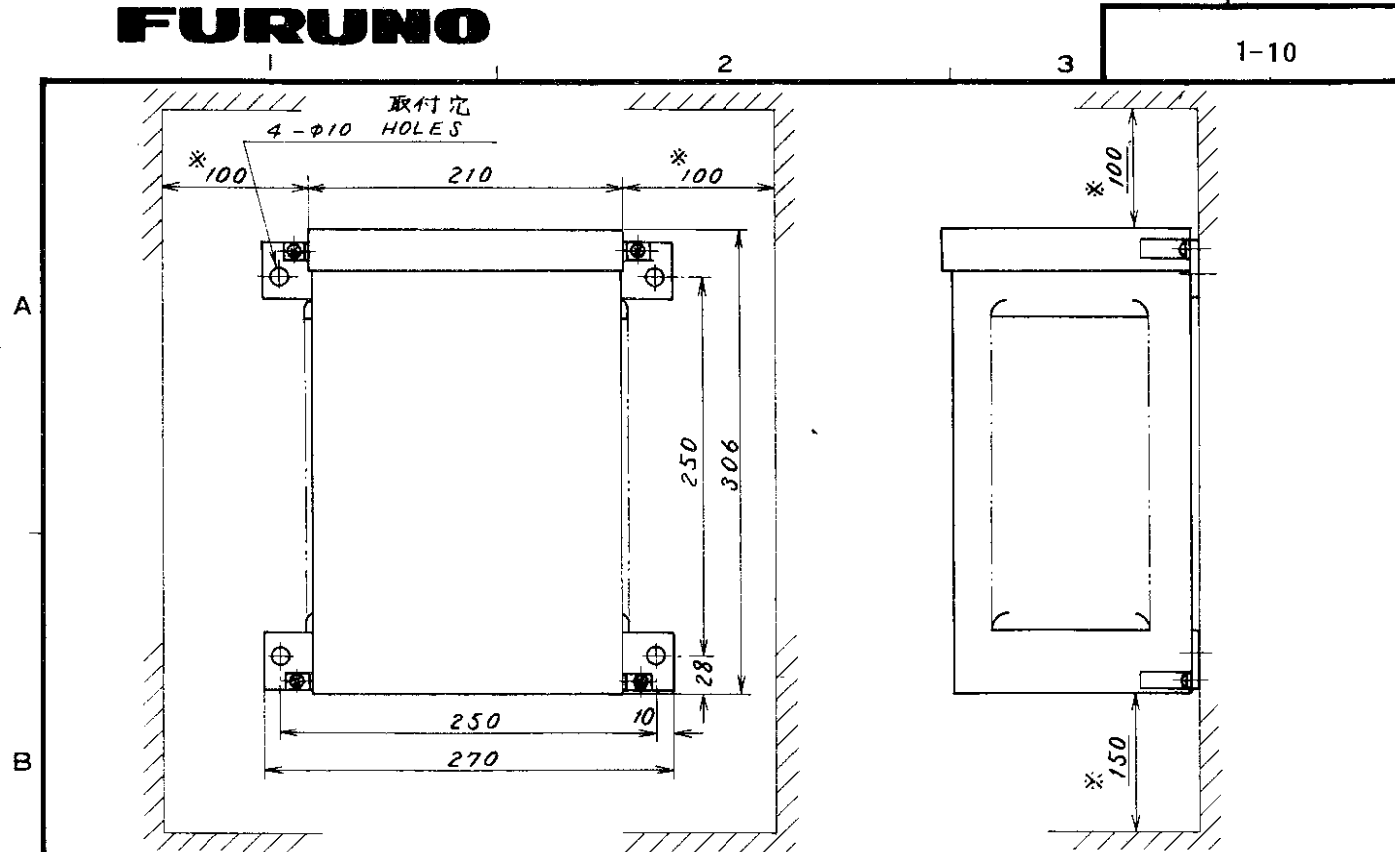

1-10

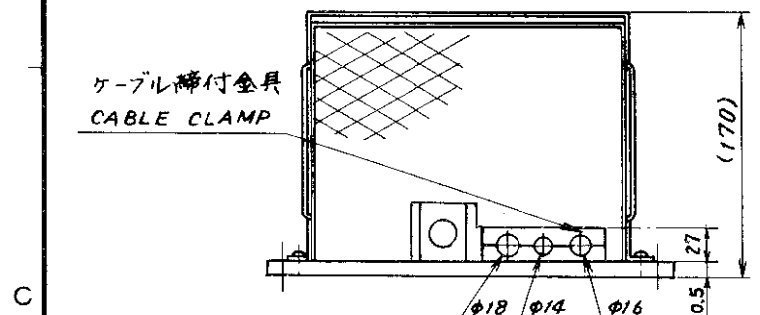

NOTE 1. ※: 推奨サービス空間。
RECOMMENDED SERVICING CLEARANCE.
2. コンパス安全距離
COMPASS SAFE DISTANCE.

スタンダード STANDARD	2.1M
ステアリング STEERING	1.5M

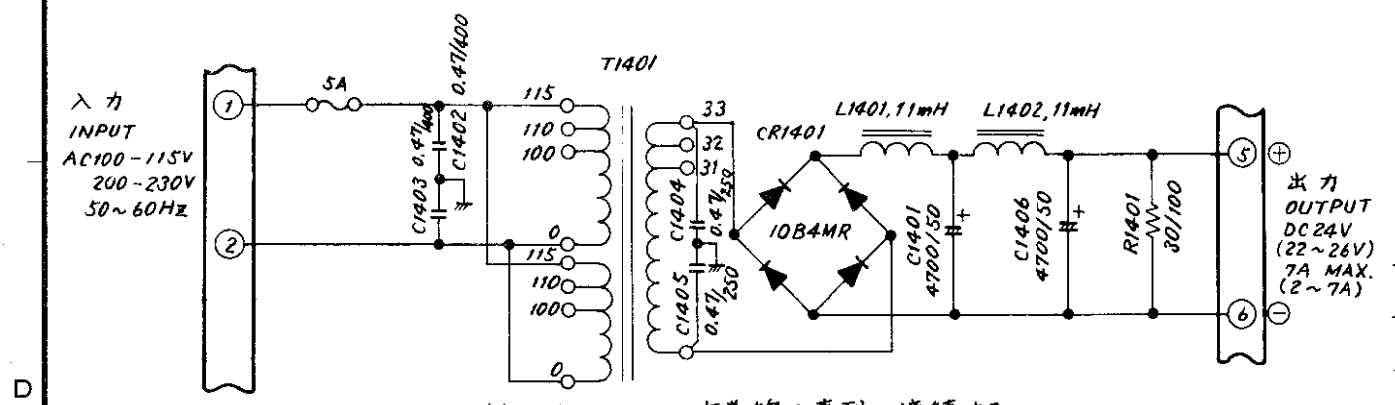

注 AC220V入力に対しては T1401の一次巻線を直列に接続する。

NOTE FOR 220VAC INPUT, CONNECT T1401 PRIMARY WINDINGS IN SERIES.

承認 APPROVED	品番 ITEM	品名 NAME	材質 MATERIAL	数量 Q'TY	図番 DWG.NO.	摘要 REMARKS
JAN 18 '79		三角法 THIRD ANGLE PROJECTION				名称 TITLE RU-3423 整流器 RECTIFIER UNIT
JAN 17 '79		尺度 SCALE 1/5				
JAN 16 '79		重量 WEIGHT 16.5kg			図番 DWG.NO. C3002-005-H	

REV.: 8/85

1.5 Connections

Connections to Display Unit

Two cables run to the display unit. These are;

- a. multicore cable from the scanner unit
- b. power cable from the ship's mains or rectifier

The multicore cable and power cable are terminated with the connectors (24P connector DP1 and 2P connector P1351) at the display side. Connect them to the display unit as shown below.

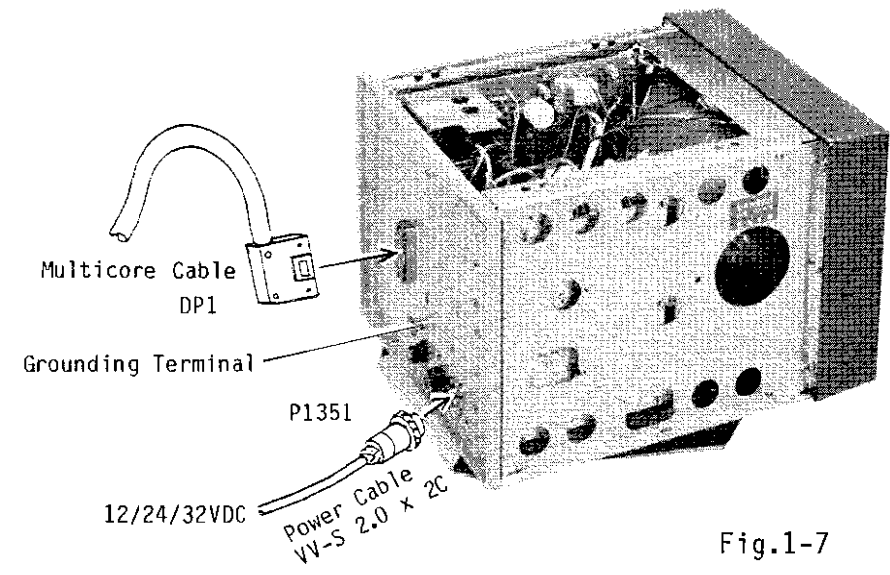

Photo No.2139

Fig.1-7

Scanner Unit Internal Wiring

The following wirings must be made in the scanner unit at installation.

1. Wiring between the scanner housing cover and scanner housing.
 - a. Six lead wires run from the scanner housing cover to terminal board RTB on the bottom of the scanner housing. Connect them as shown in Fig.1-8.
2. Wiring between the transceiver module and scanner housing.
 - a. 14 wires terminated by a 15P plug P811 run from terminal board RTB. Connect them to J811 on the transceiver module.
 - b. A black wire runs from the transceiver module. Connect it to #20 terminal of RTB.

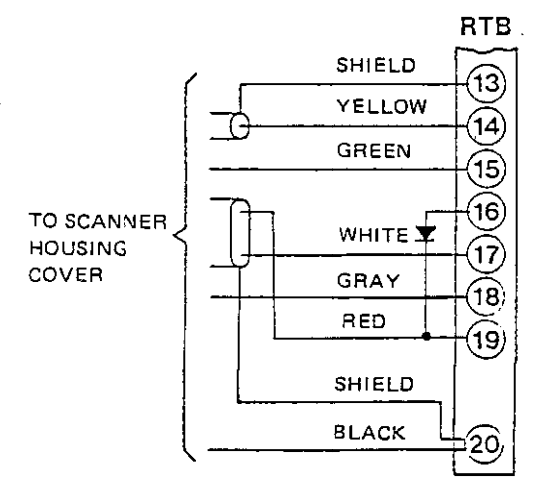

Fig.1-8

Connections to Scanner Unit

Only the multicore cable runs to the scanner unit. The procedure for connecting the multicore cable to the scanner unit is as follows.

1. Through a pipe or waterproof cable gland fitted on the wheelhouse top or bulkhead, pass the open end of the cable toward the scanner unit.
2. Open the scanner housing cover by loosening the four bolts.
3. Remove the cable gland located on the bottom of the scanner housing.

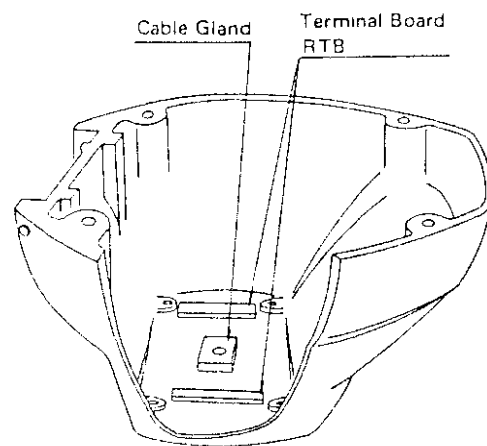

Fig.1-9

4. Pass the multicore cable through the scanner base and the cable gland (removed in step 3).
5. Cut the cable to a suitable length, and fabricate it referring to Fig.1-12.

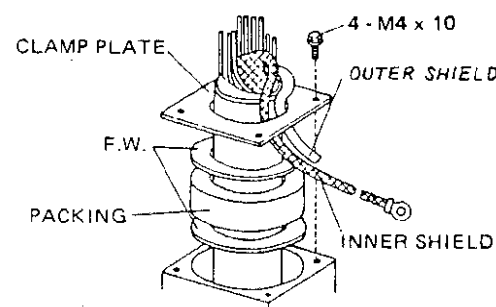

Fig.1-10

6. Connect the coaxial plug to the 1.7C2V cable. See Fig.1-12.
7. Tighten the cable gland to the scanner base for complete watertightness. Ground the outer shield of the multicore cable with the clamp plate as shown in Fig.1-12.
8. Connect the lead wires to terminal board RTB on the bottom of the scanner housing by referring to the Interconnection Diagram on page 1-15.

NOTE: The inner shield of the multicore cable should be connected at terminal #20 of RTB.

9. Connect the 1.7C2V coaxial cable to jack J601 on the transceiver module.
10. Close the scanner housing cover temporarily.

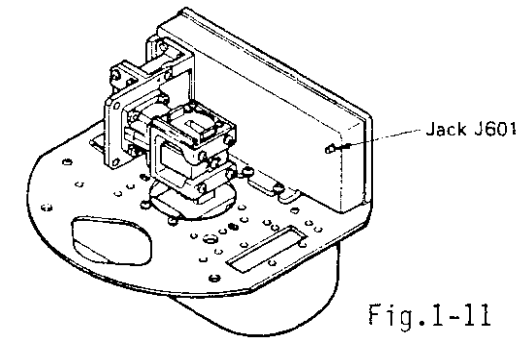

Fig.1-11 Transceiver Module

FABRICATION OF MULTICORE CABLE (SCANNER SIDE)

1. Being careful not to cut the outer shield, remove 500mm of the vinyl sheath.
2. Slide washer, rubber packing, washer and clamp plate of the gland over the cable. See Fig.1-12(b).
3. Straighten the outer shield and separate the outer layer wires from those inside the braided shield (inner wires). See Fig.1-12(c).
4. Take out the wires and coaxial wire (1.7C2V) from the inside layer. See Fig.1-12(d).
5. Mark the wires for identification.
6. Cut each lead wire to a suitable length, considering the distance to respective terminals on RTB.
7. Remove about 6mm of the vinyl insulation from the end of each wire. Fix a crimp-on lug to each wire by using a crimping tool.
8. Spread out the inner shield of the multicore cable and cut it off leaving about 250mm. Put a vinyl tube or tape over the braided shield and solder a 4mm dia. hole soldering lug on the end of the shield.
9. While holding the wire in one hand pull each crimp-on lug to ensure that the connection is tight.
10. Solder the coaxial plug to the 1.7C2V coaxial cable.

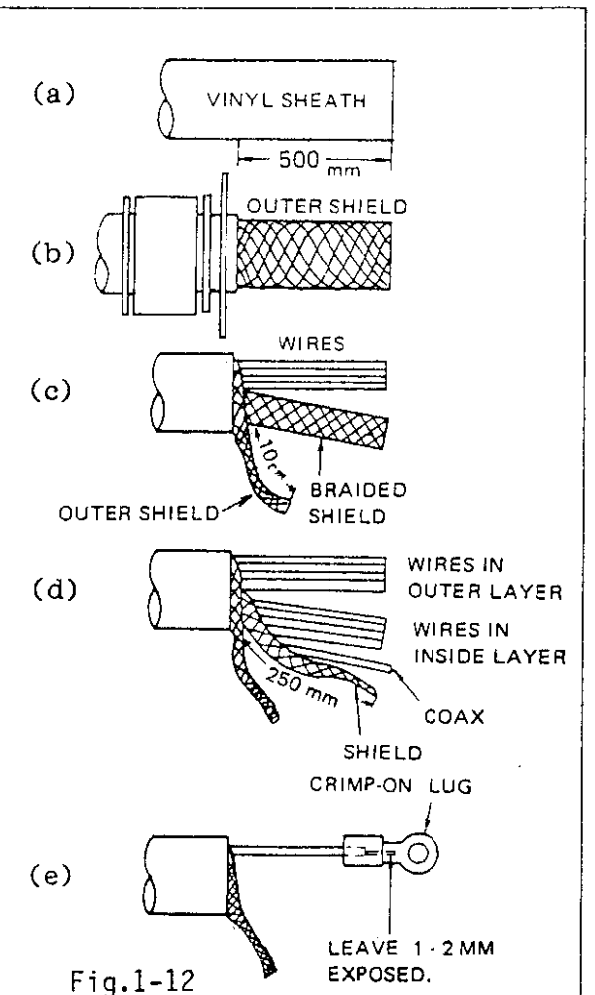
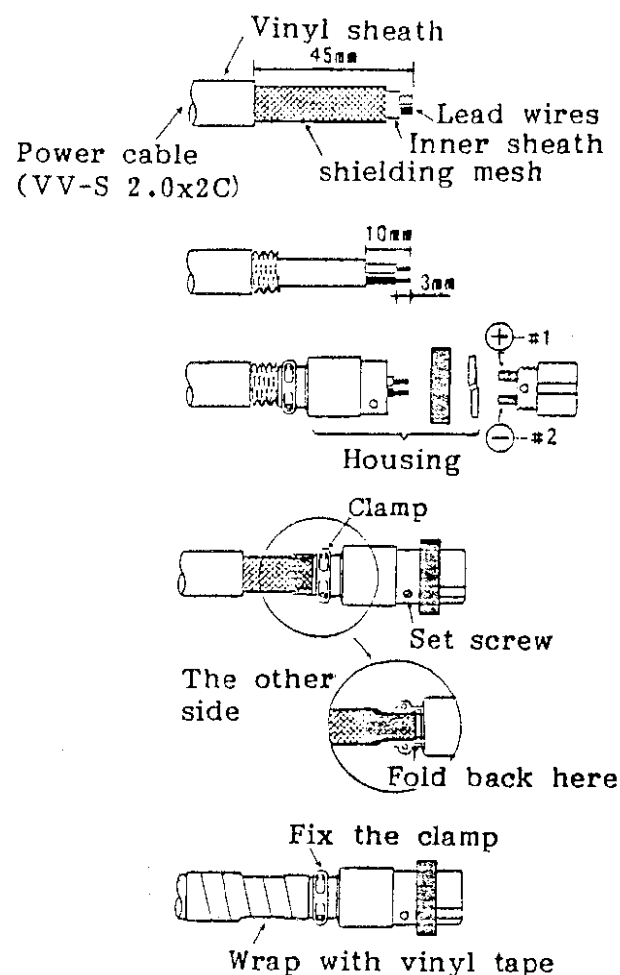

Fig.1-12

FABRICATION OF POWER CABLE

1. Remove 45mm of the vinyl sheath, taking care not to nick the shielding mesh, and then slide the shielding mesh back.
2. Remove 10mm of the inner sheath, and then remove about 3mm of the insulation from both ends of the lead wires.
3. Slide connector's housing over the cable.
4. Solder the lead wires to the connector, taking note of the polarity.

⊕ --- #1 ⊖ --- #2
5. Assemble the connector, and then tighten the set screw.
6. Fold back the shielding mesh and clamp the connector over top of it.
7. Wrap the shielding mesh with vinyl tape.



COAXIAL PLUG CONNECTION

1. Take off the plug cap. Tin the center pin and earth plate of the plug, paying attention not to fill the hole of the center pin. Cut the wirings of the earth plate by about 1mm as shown in Fig.1-13(a).
2. Remove 28mm of the vinyl sheath of the 1.7C2V as shown in Fig.1-13(b).
3. Pass the vinyl sheath through the plug cap and enlarge the mesh of the braided shield. Take out the inner conductor by using tweezers as shown in Fig.1-13(c).
4. Cut the braided shield leaving 10mm and tin it. Use the tweezers as a heat sink as shown in Fig.1-13(d) to prevent the polythelene insulator of the inner conductor from melting.
5. Remove 5mm of the polythelene insulator and tin the core.
6. Insert the inner conductor into the center pin of the plug, wind the braided shield on the soldered part of the earth plate, and solder them, paying attention not to melt the polythelene insulator. See Fig.1-13(e).
7. Fold over the wings of the earth plate on the braided shield.

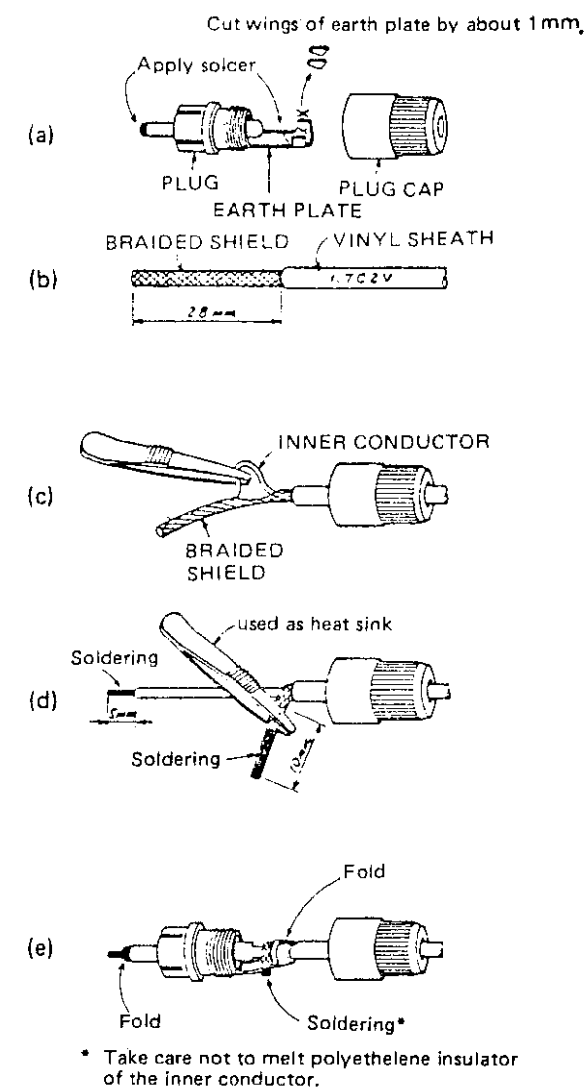
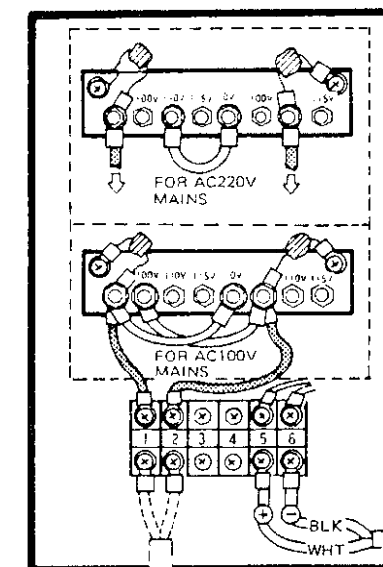
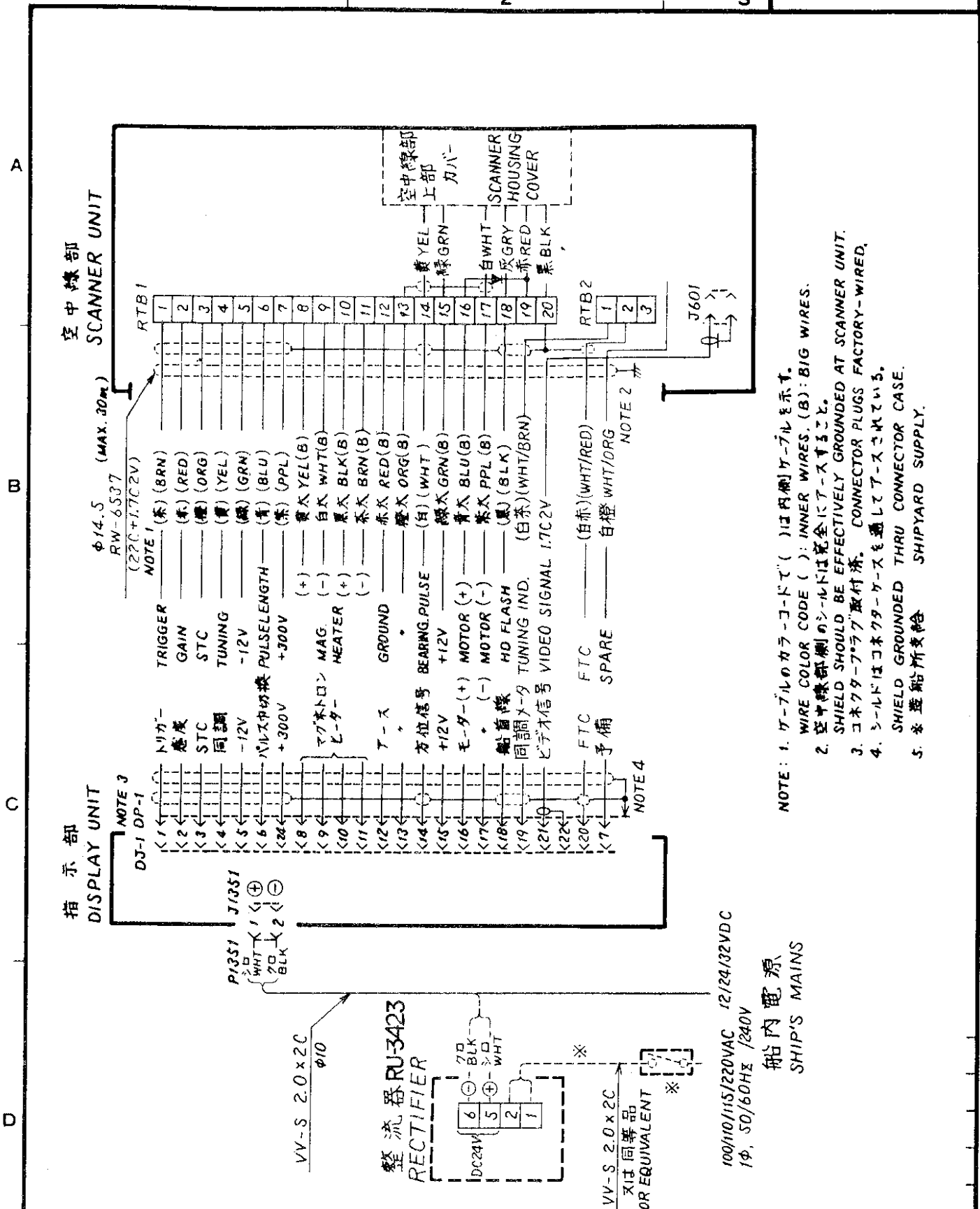

Fig.1-13

Connections to Rectifier Unit (Option)

When the ship's mains is 100/110/115/220/240VAC, a rectifier is required. For connection to this unit, refer to the Schematic Diagram on page 1-10 and the Interconnection Diagram on page 1-15.





NOTE: 1. ケーブルのカラーコードで()は内側ケーブルを示す。
 WIRE COLOR CODE () : INNER WIRES. (B) : BIG WIRES.
 2. 空中線部側のシールドは完全にアースすること。
 SHIELD SHOULD BE EFFECTIVELY GROUNDED AT SCANNER UNIT.
 3. コネクタプラグ取付時、コネクタプラグは工場ワイヤード。
 4. シールドはコネクタケースを通してアースされる。
 SHIELD GROUNDED THRU CONNECTOR CASE.
 5. * 造船所支給 SHIPYARD SUPPLY.

FURUNO ELECTRIC CO. LTD		品番 ITEM		品名 NAME		材質 MATERIAL		数量 Q'TY		図番 DWG. NO.		備考 REMARKS	
承認 APPROVED		G.W. 30.86		三角法 THIRD ANGLE PROJECTION		名称 TITLE		相互結線図 INTERCONNECTION DIAGRAM		図番 DWG. NO.		C3293-003-B	
検査 CHECKED		June 30 '86		尺 R 度 SCALE		重量 WEIGHT		kg		図番 DWG. NO.		C3293-003-B	
製図 DRAWN		June 27 '86		重量 WEIGHT		kg				図番 DWG. NO.		C3293-003-B	

CHAPTER 2 ADJUSTMENT AT INSTALLATION

Items 1 to 3 should be adjusted at installation, while items 5 to 8 (marked by *) are preadjusted at the factory. Items 5 to 8 should be adjusted only when conditions (e.g., main bang appears, sea clutter function is ineffective, etc.) make it necessary.

1. Tuning & Tuning Indicator Sensitivity
2. Sweep Timing
3. Heading Alignment
4. Magnetron Heater Voltage (Confirmation only)
5. Gain Preset (*)
6. Sea Clutter (*)
7. Rain Clutter (*)
8. Main Bang Suppression (MBS) (*)

Tuning & Tuning Indicator Sensitivity

If the best tuning condition is not obtained with the TUNE control set at its mid-travel, execute the following procedure.

NOTE: This adjustment is also required when replacing the IF amp., MIC or magnetron.

Procedure:

1. Transmit the radar on 24 n.m. range with the TUNE control set at its mid-travel and wait about 10 minutes for magnetron oscillation to stabilize.
2. Adjust potentiometer VR4 inside the inner panel (Fig.2-1), located at the left hand side of the display unit, so that a comparatively weak long range echo is discerned with maximum definition. At this time, confirm that best picture definition is obtained with the maximum number of tuning markers displayed. If not, adjustment on the MBS board in the scanner unit should be made as follows.

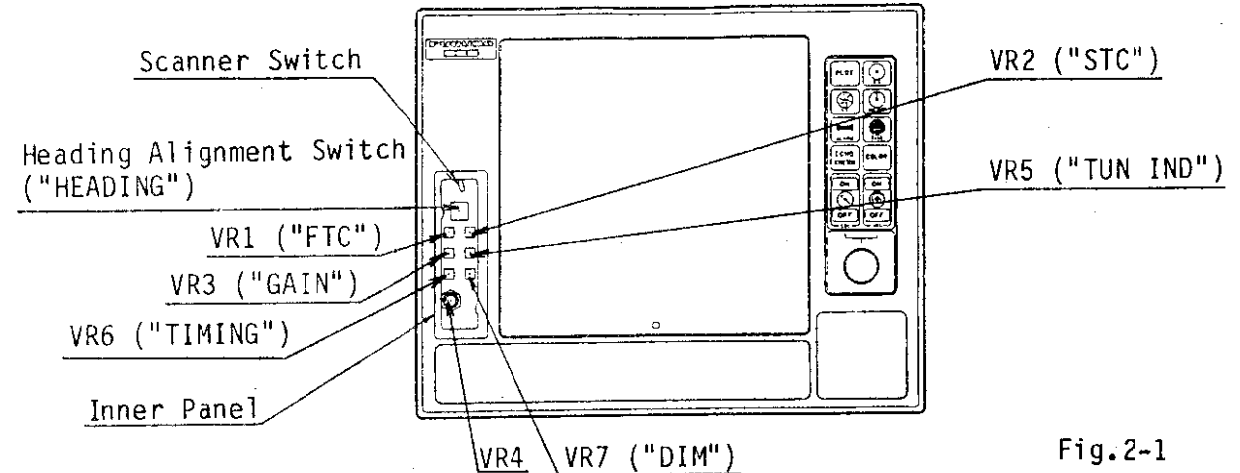
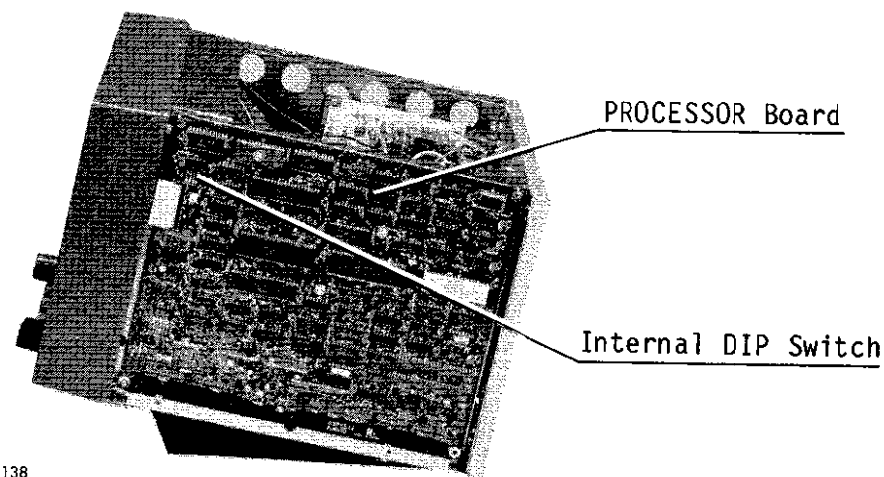

Fig.2-1

- a. Turn off the radar and set pin #3 of the internal DIP switch on the PROCESSOR board to the "ON" position, then switch on the radar again.



N Photo No.2138

Fig.2-2 Right View of Display Unit

- b. Transmit the radar again and wait for about 10 minutes.
- c. Turn off the scanner switch (Fig.2-1), and antenna rotation is suspended under transmission condition.
- d. Open the scanner cover and adjust potentiometer VR1 on the MBS board for maximum brilliance of CR1 on the MBS board. See Fig.2-3.

NOTE: VR1 can be adjusted by measuring the voltage at RTB2 #1 with a multimeter. For instance, adjust VR1 for maximum deflection on the meter (Approx. 3V).

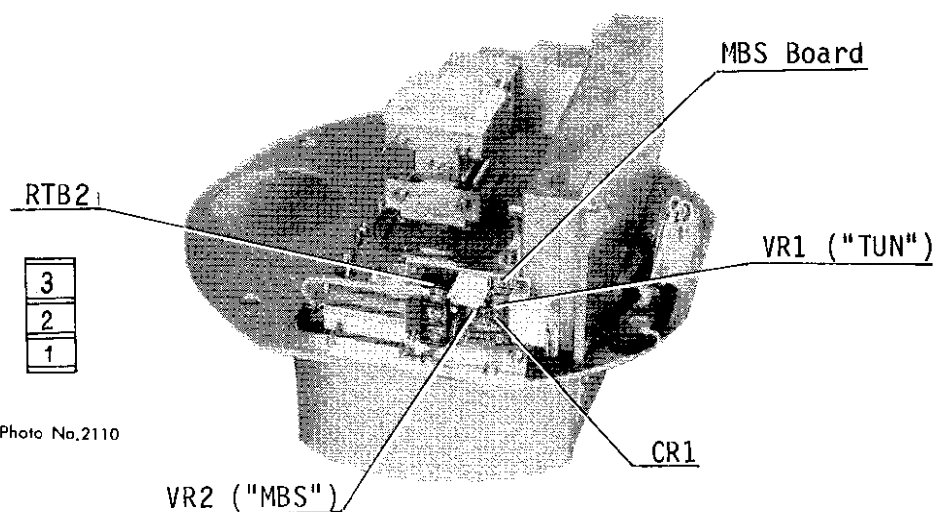

N Photo No.2110

Fig.2-3 Transceiver Module

- e. Turn on the scanner switch and confirm that best picture definition is obtained with the maximum number of tuning markers displayed.
 - f. Turn off the radar and set pin #3 of the internal DIP switch to the "OFF" position, then switch on the radar again.
3. Adjust potentiometer VR5 (Fig.2-1) so that four tuning markers light up with the fifth one blinking.

Sweep Timing

Sweep timing differs with respect to the length of the multicore cable between the display and scanner units. Perform the following adjustment at installation even if the standard cable of 10 meters was used.

Procedure:

1. Set the radar at 0.25 n.m. range and adjust the GAIN and SEA CLUTTER controls to obtain the picture.
2. Visually, select a straight object, e.g., a harbor wall, straight pier, etc.
3. Adjust potentiometer VR6 (Fig.2-1) so that the straight object appears straight with no "pushing" or "pulling" near the center of the picture. See Fig.2-4.

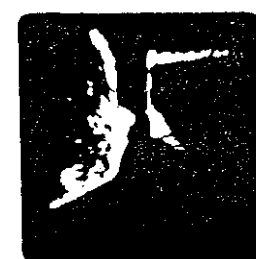

(A) Improper, pulling inward



(B) Proper



(C) Improper, pushing outward

Fig.2-4 Sweep Timing Adjustment

Heading Alignment

Procedure:

1. Operate the radar to obtain a normal picture on the screen.
2. Select a proper target echo (small island, end of quay, etc.) located on or around the heading flash and near the edge of the screen.
3. Press the EBL touchpad to present a EBL on the screen.
4. Operate the Marker control until the EBL is positioned over the center of a target.

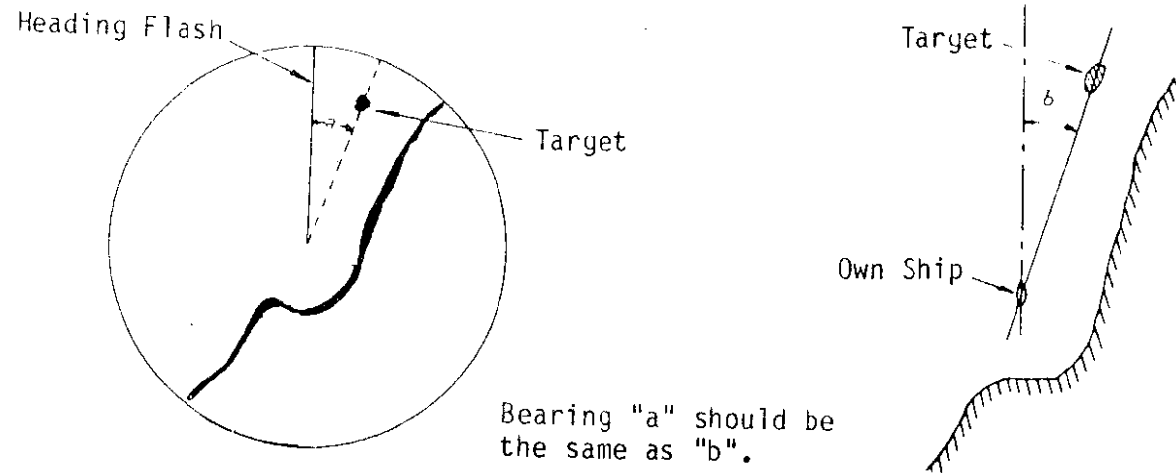

Fig.2-5

5. Read the EBL bearing at the bottom left of the screen. Next, by watching the ship's compass, find the relative bearing of the target from the ship's heading on the navigational chart. The relative bearing can also be made by visually measuring the direction of the target from the ship's bow using a dumb card.
6. The bearing of the target from the heading flash on the screen should be the same as that found on the navigational chart or the visual measurement. If there is a difference between them, adjust the Heading Alignment switch inside the inner panel in the display unit (Fig.2-1) to compensate for the difference (adjustable $\pm 5^\circ$).

NOTE: When the adjustment can not be completed by the Heading Alignment switch, turn off the scanner switch (Fig.2-1) to suspend antenna rotation and change the position of the reed switch mount in the scanner unit (Fig.2-6 on the next page), then readjust the Heading Alignment switch. This should be made if the scanner unit is installed with a large error in direction.

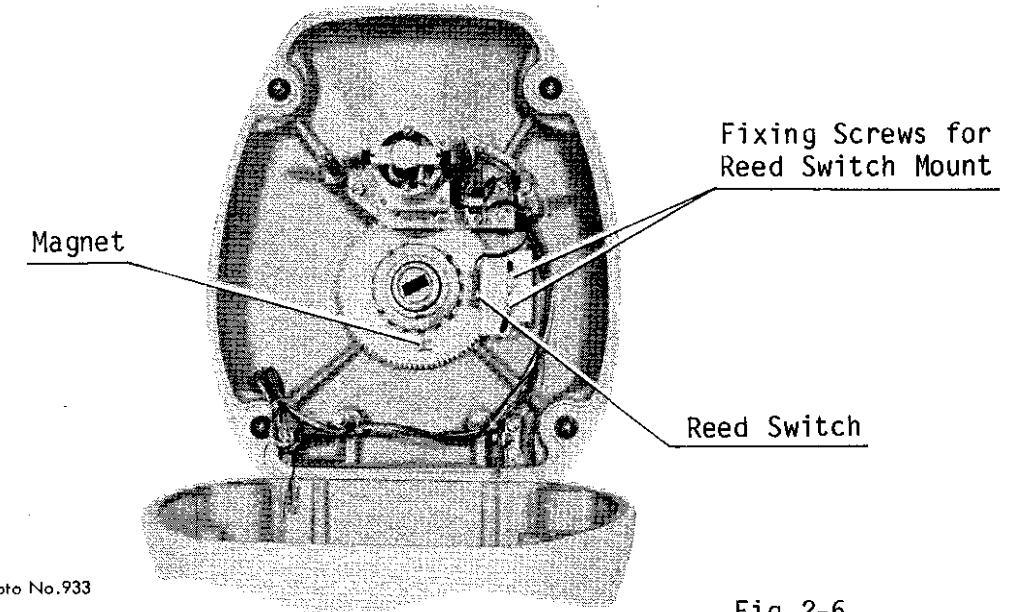

Fig.2-6

Magnetron Heater Voltage (Confirmation only)

Procedure:

1. Operate the radar in standby and 0.25 n.m. range.
2. Connect a multimeter, set to 10VDC range, between terminals #4(+) and #6(-) of the pulse transformer.
3. Confirm that the voltage is 6.0 to 6.6VDC.

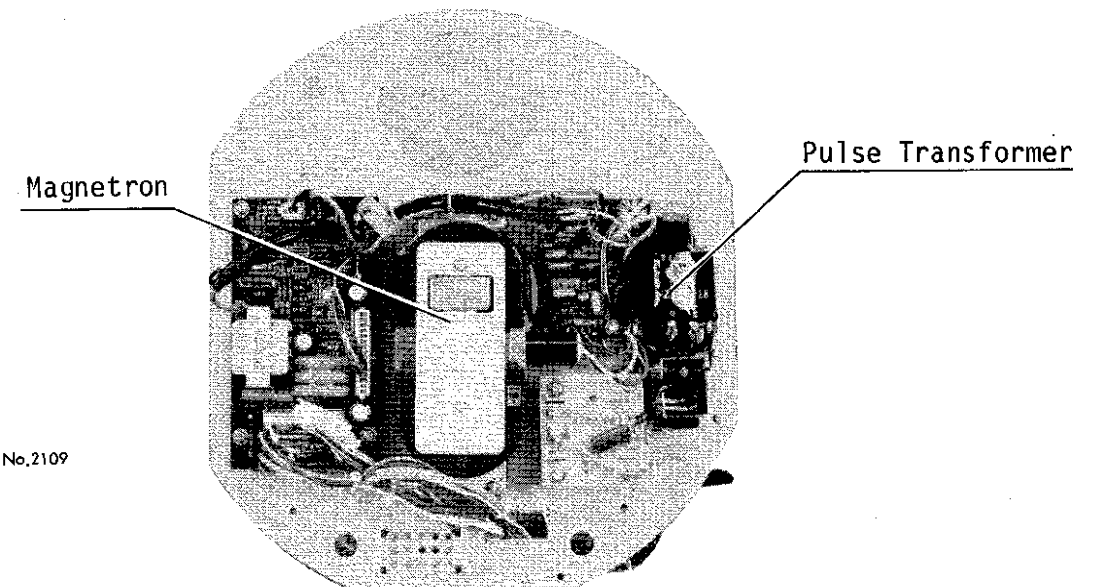

Fig.2-7 Bottom View of Transceiver Module

Gain Preset

Procedure:

1. Transmit the radar on 24 n.m. range.
2. Set the controls and touchpad keys as follows.
SEA CLUTTER: Fully CCW, IR: "ON", ECHO STRETCH: "OFF",
RAIN CLUTTER: Fully CCW (pushed), GAIN: 3 o'clock position
3. Adjust potentiometer VR3 inside the inner panel (Fig.2-1) so that a little background noise (white noise) appears on the screen.

Sea Clutter

Procedure:

1. Transmit the radar on 12 n.m. range.
2. Set the controls and touchpad keys as follows.
SEA CLUTTER: Fully CW, RAIN CLUTTER: Fully CCW (pushed),
IR: "ON", ECHO STRETCH: "OFF"
3. Tune the radar and turn the GAIN control so that the noise appears on the screen.
4. Adjust potentiometer VR2 inside the inner panel (Fig.2-1) so that the effective range of the sea clutter is 3 to 6 n.m.

Rain Clutter

Procedure:

1. Transmit the radar on 24 n.m. range.
2. Set the controls and touchpad keys as follows.
RAIN CLUTTER: Fully CW (pushed), SEA CLUTTER: Fully CCW,
GAIN: Fully CW, IR: "ON", ECHO STRETCH: "OFF"
3. Tune the radar and adjust potentiometer VR1 inside the inner panel so that the effective range of the rain clutter is 12 to 20 n.m.

Main Bang Suppression (MBS)

If main bang appears on the screen, perform the following adjustment after adjustments of Sweep Timing and Tuning/Tuning Indicator Sensitivity are made.

Procedure:

1. Tune the radar on 12 n.m. range and adjust the GAIN control so that a slight amount noise appears on the screen.
2. Set the range at 0.25 n.m. and adjust the SEA CLUTTER control so that picture appears with best definition.
3. Open the scanner cover and place a block of wood or similar material under the cover to adjust VR2 (Fig.2-3) on the MBS board.

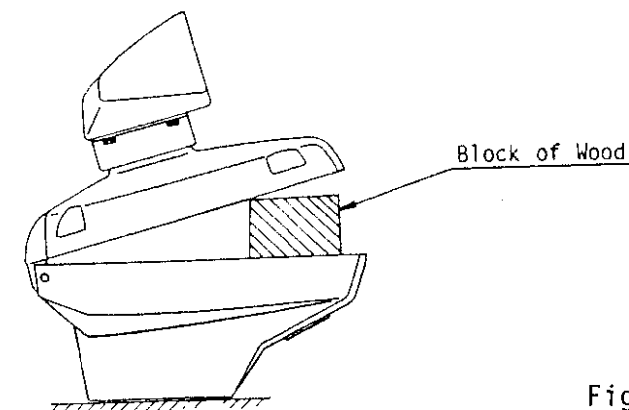

Fig.2-8

4. Adjust VR2 so that the main bang disappears from the screen, that is, the outer edge of the black hole shown below is at 0.014 n.m. when measured by the VRM.

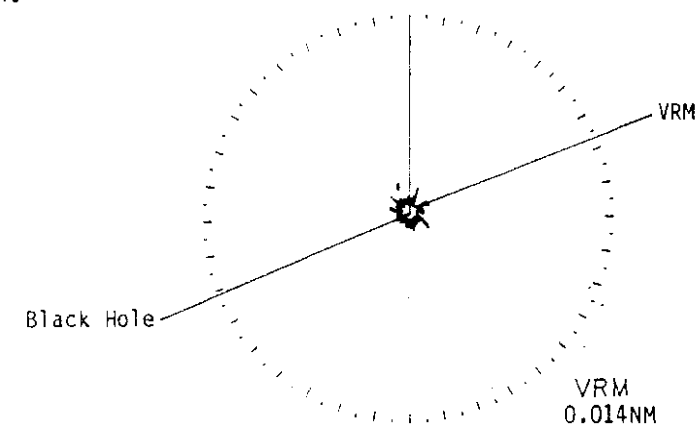

Fig.2-9

Note that the illumination of the touchpads/front panel can be adjusted by the illumination pot. (VR7, "DIM") in the inner panel. See Fig.2-1. Clockwise turning of VR7 will increase the illumination.

APPENDIX 1 CHANGING THE SPECIFICATIONS BY AN INTERNAL DIP SWITCH

A 4-bit DIP switch S1 is located on the PROCESSOR board (03P6541). The specifications of the radar are changed according to the setting of the DIP switch, as shown below.

NOTE: When the change of the DIP switch setting is required in the field, turn off the radar before changing the setting.

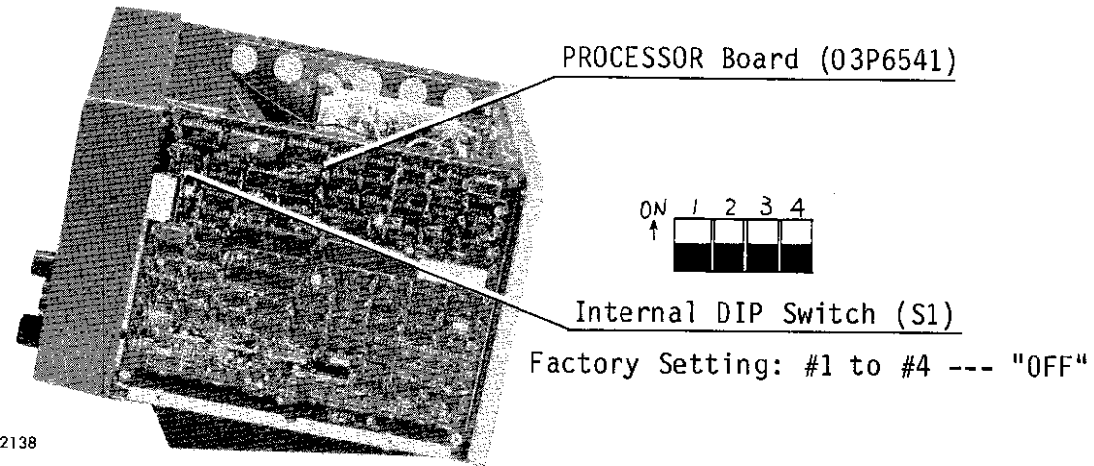

N Photo No.2138

Switch Number	Specification
Switch #2	<p>ON - The range value of No.2 VRM and the fixed range ring interval on the 0.25 and 0.5nm ranges are both displayed in kilometers. (There are 4 range ring intervals on the 0.25nm range, each at a 0.1km interval. And the fixed range rings on the 0.5nm range are spaced every 0.2km).</p> <p>OFF - The value of No.2 VRM and the interval of the range rings are displayed in nautical miles.</p>
Switch #3	<p>ON - When the antenna switch (located in the inner panel) is set to OFF during transmission, antenna rotation is suspended.</p> <p>OFF - When the antenna switch is set to OFF during transmission, antenna rotation is suspended and the radar is put in standby condition.</p>
Switch #4	<p>ON - The range of the alarm is fixed between 3 and 6nm.</p> <p>OFF - Any range may be used to set the alarm.</p>

NOTE: DIP switch #1 is set at the factory; do not change the position.

APPENDIX 2 ALTERATION OF POWER SUPPLY

By changing the main fuse and jumper connections on the POWER SUPPLY board (03P6542) in the display unit, the radar can be operated from either 12VDC or 24/32VDC. (No modification is required for change between 24 and 32VDC.)

Mains Input	Main Fuse
12VDC (10.2 to 15.0V)	15A
24/32VDC (20.4 to 40.0V)	10A

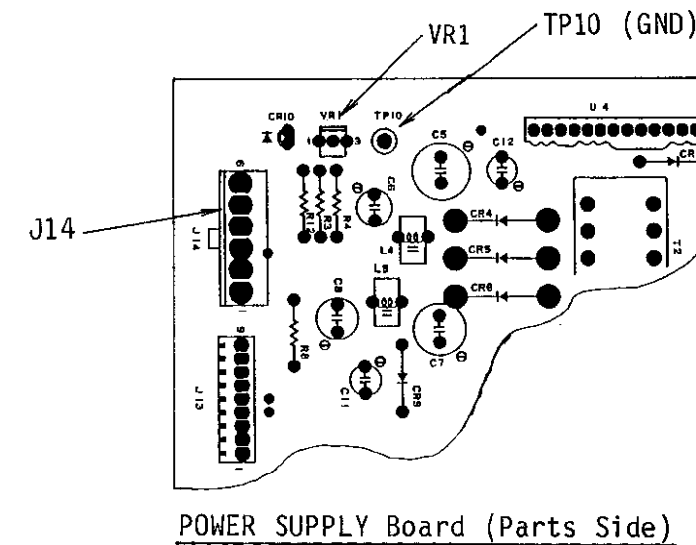
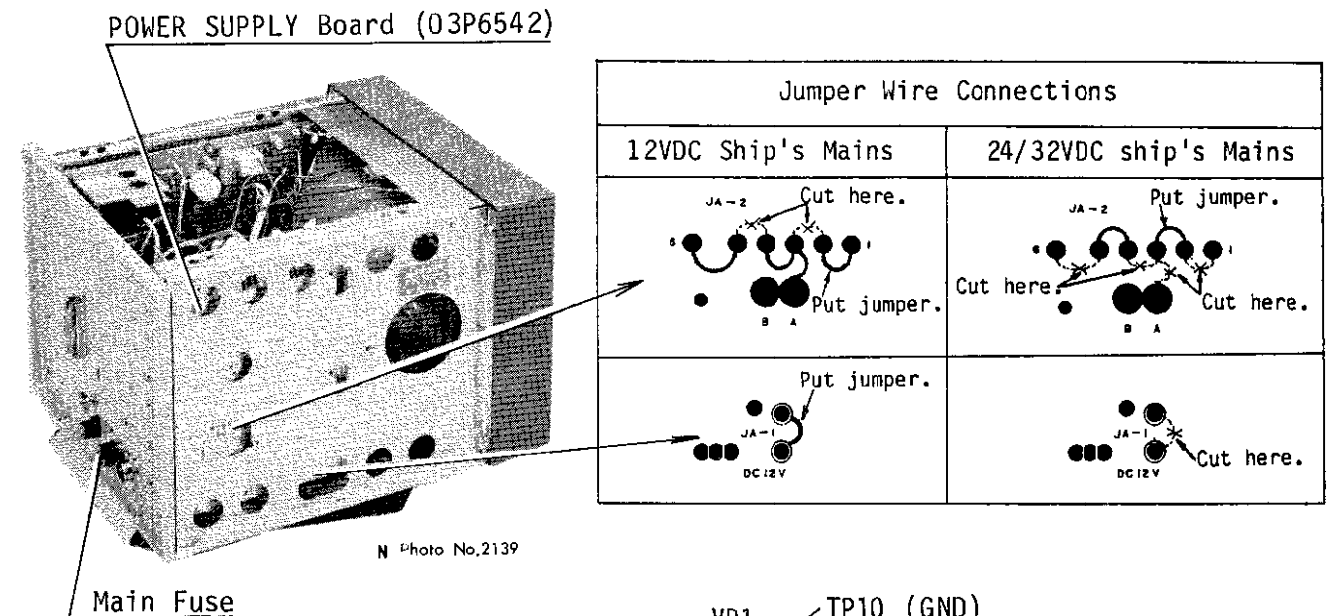

When the above modification is done, confirm that 12V line voltage is within the rating (11.8 ± 0.1V) by measuring the voltage between pin #5 (+) of J14 and TP10 (GND) on the POWER SUPPLY board. If not, adjust VR1 on the POWER SUPPLY board for the rating.



FURUNO ELECTRIC CO., LTD.

No. 9-52, ASHIHARA-CHO,
NISHINOMIYA-CITY, JAPAN

TELEPHONE : 0798-65-2111
CABLE : FURUNO NISHINOMIYA
TELEX : 5644-325/326 FURUNO J
TELEFAX : 0798-65-4200 (G II /G III)

YOUR LOCAL AGENT/DEALER