

User Guide

RT-N56U

Extreme Performance in Style

Dual-band Wireless-N Gigabit Router

The ultra-thin and stylish RT-N56U features a 2.4GHz and 5GHz dual bands for an unmatched concurrent wireless HD streaming; built-in ASUS Download Master that support HTTP, FTP, and BT protocols for uninterrupted download tasks; SMB server, UPnP AV server, and FTP server for 24/7 file sharing; a capability to handle 300,000 sessions; and the ASUS Green Network Technology, which provides up to 70% power-saving solution.

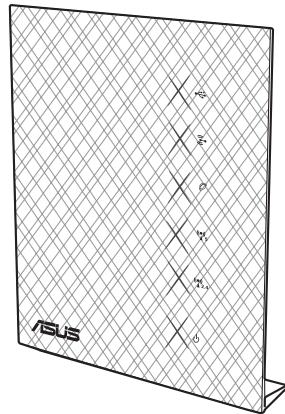

ASUS[®]
Inspiring Innovation • Persistent Perfection

E6486

Fourth Edition

April 2011

Copyright © 2011 ASUSTeK Computer Inc. All Rights Reserved.

No part of this manual, including the products and software described in it, may be reproduced, transmitted, transcribed, stored in a retrieval system, or translated into any language in any form or by any means, except documentation kept by the purchaser for backup purposes, without the express written permission of ASUSTeK Computer Inc. (“ASUS”).

Product warranty or service will not be extended if: (1) the product is repaired, modified or altered, unless such repair, modification or alteration is authorized in writing by ASUS; or (2) the serial number of the product is defaced or missing.

ASUS PROVIDES THIS MANUAL “AS IS” WITHOUT WARRANTY OF ANY KIND, EITHER EXPRESS OR IMPLIED, INCLUDING BUT NOT LIMITED TO THE IMPLIED WARRANTIES OR CONDITIONS OF MERCHANTABILITY OR FITNESS FOR A PARTICULAR PURPOSE. IN NO EVENT SHALL ASUS, ITS DIRECTORS, OFFICERS, EMPLOYEES OR AGENTS BE LIABLE FOR ANY INDIRECT, SPECIAL, INCIDENTAL, OR CONSEQUENTIAL DAMAGES (INCLUDING DAMAGES FOR LOSS OF PROFITS, LOSS OF BUSINESS, LOSS OF USE OR DATA, INTERRUPTION OF BUSINESS AND THE LIKE), EVEN IF ASUS HAS BEEN ADVISED OF THE POSSIBILITY OF SUCH DAMAGES ARISING FROM ANY DEFECT OR ERROR IN THIS MANUAL OR PRODUCT.

SPECIFICATIONS AND INFORMATION CONTAINED IN THIS MANUAL ARE FURNISHED FOR INFORMATIONAL USE ONLY, AND ARE SUBJECT TO CHANGE AT ANY TIME WITHOUT NOTICE, AND SHOULD NOT BE CONSTRUED AS A COMMITMENT BY ASUS. ASUS ASSUMES NO RESPONSIBILITY OR LIABILITY FOR ANY ERRORS OR INACCURACIES THAT MAY APPEAR IN THIS MANUAL, INCLUDING THE PRODUCTS AND SOFTWARE DESCRIBED IN IT.

Products and corporate names appearing in this manual may or may not be registered trademarks or copyrights of their respective companies, and are used only for identification or explanation and to the owners’ benefit, without intent to infringe.

Table of contents

1 A quick look	
Package contents	5
Your wireless router	5
Mounting placement	7
2 Creating your network	
Positioning your router	8
What you need.....	9
Setting up your wireless router	10
Wired connection	10
Wireless connection.....	11
Before you proceed	12
A. Disable the proxy server, if enabled.....	12
B. Set the TCP/IP settings to automatically obtain an IP address.....	14
C. Disable the dial-up connection, if enabled.	15
3 Configuring via the web GUI	
Logging into the web GUI.....	16
Setting up the Internet connection	18
Quick Internet Setup (QIS) with auto-detection	18
Using Wi-Fi Protected Setup (WPS)	20
Setting up the wireless security settings	22
Managing your network clients	24
Monitoring your USB device	25
Using your router as a UPnP Media Server	27
Using AiDisk for an FTP Server and Network Neighborhood setup	28
Managing EZQoS Bandwidth.....	31
Configuring the Advanced settings.....	33
Setting up the DHCP Server	33

Table of contents

- Upgrading the firmware35
- Restoring/Saving/Uploading settings36
- Sharing files from a USB storage device37
- Setting up your network printer42**

- 4 Using the utilities**
 - Device Discovery46**
 - Firmware Restoration47**
 - Download Master48**

- 5 Troubleshooting**
 - Troubleshooting52**
 - ASUS DDNS Service.....55**
 - Frequently Asked Questions (FAQs).....55

- Appendices**
 - Notices57**
 - ASUS Contact information69**
 - Networks Global Hotline Information.....70**

1 A quick look

Package contents

- ☑ RT-N56U Wireless Router
- ☑ Power adapter
- ☑ Support CD (Manual, utility software)
- ☑ Network cable (RJ-45)
- ☑ Quick Start Guide
- ☑ Warranty card



NOTES:

- If any of the items is damaged or missing, contact ASUS for technical inquiries and support, Refer to the ASUS Support Hotline list at the back of this user manual.
- Keep the original packaging material in case you would need future warranty services such as repair or replacement.

Your wireless router

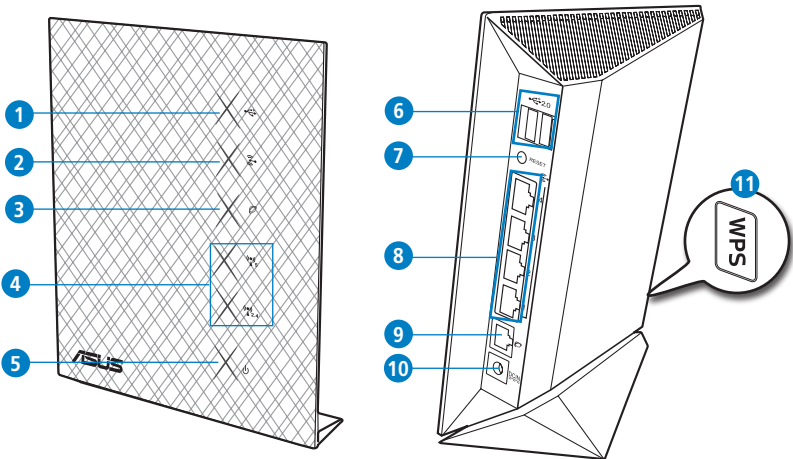

1

USB LED

Off: No power or no physical connection.

On: Has physical connection to USB devices.

2

LAN LED

Off: No power or no physical connection.

On: Has physical connection to a local area network (LAN).

3

WAN LED

Off: No power or no physical connection.

On: Has physical connection to a wide area network (WAN).

4

5GHz LED / 2.4GHz LED

Off: No 5GHz or 2.4GHz signal.

On: Wireless system is ready.

Flashing: Transmitting or receiving data via wireless connection.

5

Power LED

Off: No power.

On: Device is ready.

Flashing slow: Rescue mode

Flashing quick: WPS is processing.

6

USB 2.0 ports

Insert USB 2.0 devices such as USB hard disks or USB flash drives into these ports.

Insert your iPad's USB cable into one of these ports to charge your iPad.

7

Reset button

This button resets or restores the system to its factory default settings.

8

LAN 1 ~ 4 ports

Connect network cables into these ports to establish LAN connection.

Yellow LED: 1000Mbps connection.

Green LED: 10Mbps/100Mbps connection.

Flashing: Transmitting or receiving data via wired connection.



9

WAN (Internet) port

Connect a network cable into this port to establish WAN connection.

Yellow LED: 1000Mbps connection.

Green LED: 10Mbps/100Mbps connection.

Flashing: Transmitting or receiving data via wired connection.



10

Power (DC-In) port

Insert the bundled AC adapter into this port and connect your router to a power source.

11

WPS button

This button launches the WPS Wizard.

Mounting placement

To mount the wireless router into its stand:

1. Locate the two mounting holes at the bottom of the wireless router.
2. Latch the stand's two mounting hooks to the wireless router's mounting holes.
3. Slide the wireless router to direction of the arrow to secure it to its stand.

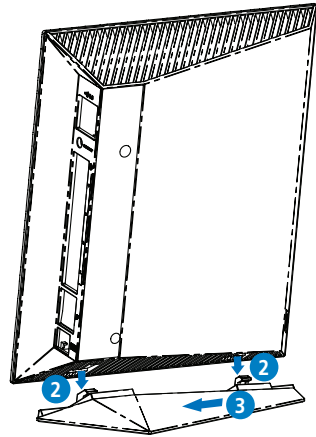

NOTES:

- Use only the adapter that came with your package. Using other adapters may damage the device.
- **Specifications:**

DC Power adapter	DC Input: +19V with max 1.58A current; +12V with max 2A current		
Operating Temperature	0~40°C	Storage	0~70°C
Operating Humidity	50~90%	Storage	20~90%

2 Creating your network

Positioning your router

For the best wireless signal transmission between the wireless router and the network devices connected to it, ensure that you:

- Place the wireless router in a centralized area for a maximum wireless coverage for the network devices.
- Keep the device away from metal obstructions and away from direct sunlight.
- Keep the device away from 802.11g or 20MHz only Wi-Fi devices, 2.4GHz computer peripherals, Bluetooth devices, cordless phones, transformers, heavy-duty motors, fluorescent lights, microwave ovens, refrigerators, and other industrial equipment to prevent signal interference or loss.
- For the best front-to-rear coverage, place the wireless router in an upright position.
- For the best up-and-down coverage, place the wireless router in an inclined position.
- Always update to the latest firmware. Visit the ASUS website at <http://www.asus.com> to get the latest firmware updates.

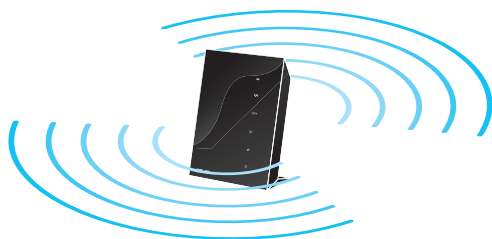

What you need

To set up your network, you need one or two computers that meet the following system requirements:

- Ethernet RJ-45 (LAN) port (10Base-T/100Base-TX/1000BaseTX)
- IEEE 802.11a/b/g/n wireless capability
- An installed TCP/IP service
- Web browser such as Internet Explorer, Firefox, Safari, or Google Chrome



NOTES:

- If your computer does not have built-in wireless capabilities, you may install an IEEE 802.11a/b/g/n WLAN adapter to your computer to connect to the network.
 - With its dual band technology, your wireless router supports 2.4GHz and 5GHz wireless signals simultaneously. This allows you to do Internet-related activities such as Internet surfing or reading/writing e-mail messages using the 2.4GHz band while simultaneously streaming high-definition audio/video files such as movies or music using the 5GHz band.
 - If you are using only one computer with single band IEEE 802.11b/g/n WLAN adapter, you will only be able to use the 2.4GHz band.
 - If you are using only one computer with dual band IEEE 802.11a/b/g/n WLAN adapter, you will be able to use the 2.4GHz or 5GHz band.
 - If you are using two computers with both IEEE 802.11a/b/g/n WLAN adapters, you will be able to use both 2.4GHz and 5GHz bands simultaneously.
 - The Ethernet RJ-45 cables that will be used to connect the network devices should not exceed 100 meters.
-

Setting up your wireless router



IMPORTANT!

- Use wired connection in setting up your wireless router to avoid possible setup problems due to wireless uncertainty.
- Before setting up your ASUS wireless router, do the following:
 - If you are replacing an existing router, disconnect it from your network.
 - Disconnect the cables/wires from your existing modem setup. If your modem has a backup battery, remove it as well.
 - Reboot your computer (recommended).

Wired connection



NOTE: Your wireless router has an integrated auto-crossover function, so use either straight-through or crossover cable for wired connection.

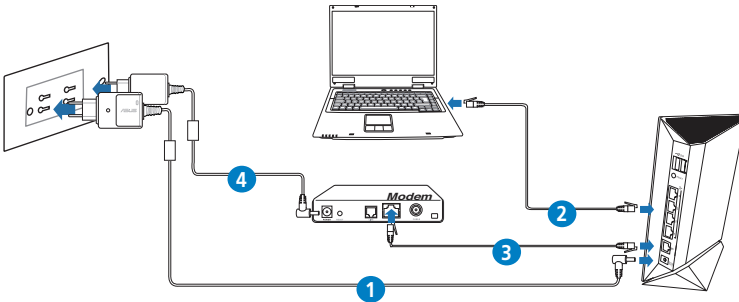

To set up your wireless router via wired connection:

1. Insert your wireless router's AC adapter to the DC-In port and plug it to a power outlet.

- Using the bundled network cable, connect your computer to your wireless router's LAN port.



IMPORTANT! Ensure that the LAN LED is blinking.

- Using another network cable, connect your modem to your wireless router's WAN port.
- Insert your modem's AC adapter to the DC-In port and plug it to a power outlet.

Wireless connection

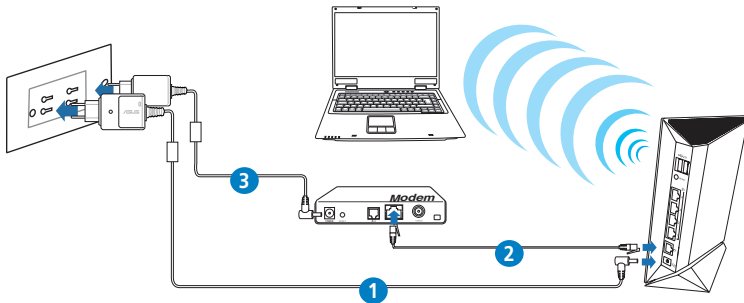

To set up your wireless router via wired connection:

- Insert your wireless router's AC adapter to the DC-In port and plug it to a power outlet.
- Using the bundled network cable, connect your modem to your wireless router's WAN port.
- Insert your modem's AC adapter to the DC-In port and plug it to a power outlet.
- Install an IEEE 802.11a/b/g/n WLAN adapter on your computer.



NOTES:

- For details on connecting to a wireless network, refer to the WLAN adapter's user manual.
- To set up the security settings for your network, refer to the section **Setting up the wireless security settings** in this user manual.

Before you proceed



NOTE: Before configuring your wireless router, do the steps described in this section for your host computer and network clients.

A. Disable the proxy server, if enabled.

Windows® 7

1. Click **Start > Internet Explorer** to launch the browser.
2. Click **Tools > Internet options > Connections** tab > **LAN settings**.

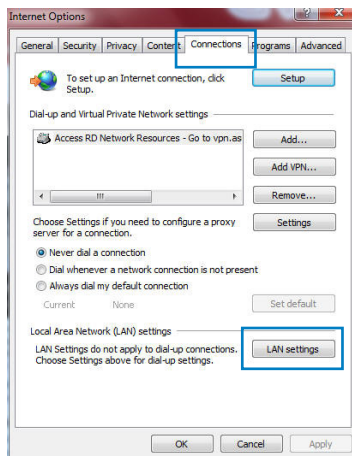

- From the Local Area Network (LAN) Settings screen, untick **Use a proxy server for your LAN**.
- Click **OK** when done.

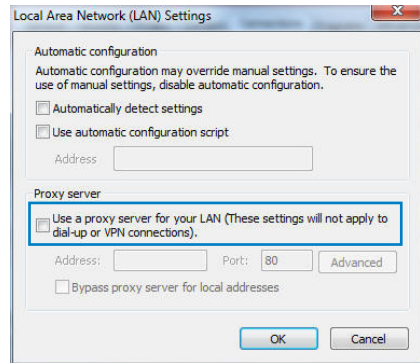

MAC OS

- From your Safari browser, click **Safari > Preferences > Advanced > Change Settings...**
- From the Network screen, deselect **FTP Proxy** and **Web Proxy (HTTP)**.
- Click **Apply Now** when done.

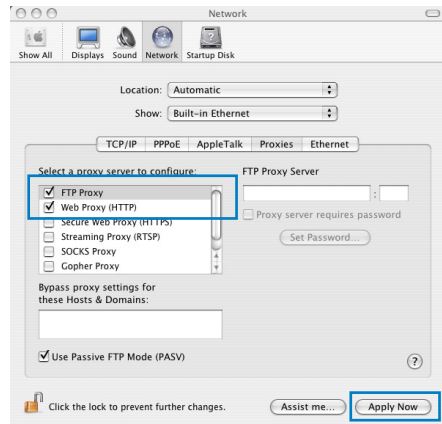

NOTE: Refer to your browser's help feature for details on disabling the proxy server.

B. Set the TCP/IP settings to automatically obtain an IP address.

Windows® 7

1. Click **Start > Control Panel > Network and Internet > Network and Sharing Center > Manage network connections.**
2. Select **Internet Protocol Version 4 (TCP/IPv4)** or **Internet Protocol Version 6 (TCP/IPv6)**, then click **Properties.**

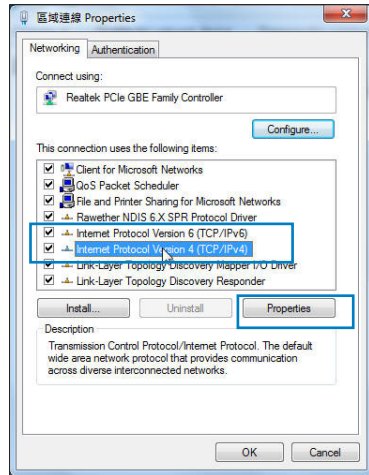

3. To obtain the IPv4 IP settings automatically, tick **Obtain an IP address automatically.**

To obtain the IPv6 IP settings automatically, tick **Obtain an IPv6 address automatically.**

4. Click **OK** when done.

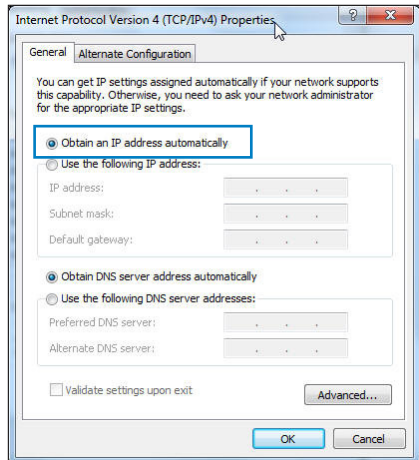

MAC OS

1. Click the Apple icon  located on the top left of your screen.
2. Click **System Preferences > Network > Configure...**
3. From the **TCP/IP** tab, select **Using DHCP** in the **Configure IPv4** dropdown list.
4. Click **Apply Now** when done.

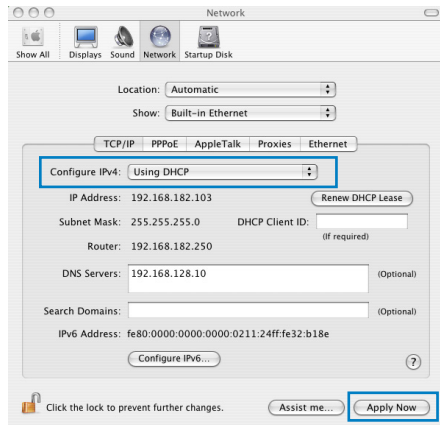

NOTE: Refer to your operating system's help and support feature for details on configuring your computer's TCP/IP settings.

C. Disable the dial-up connection, if enabled.

Windows® 7

1. Click **Start > Internet Explorer** to launch the browser.
2. Click **Tools > Internet options > Connections** tab.
3. Tick **Never dial a connection**.
4. Click **OK** when done.

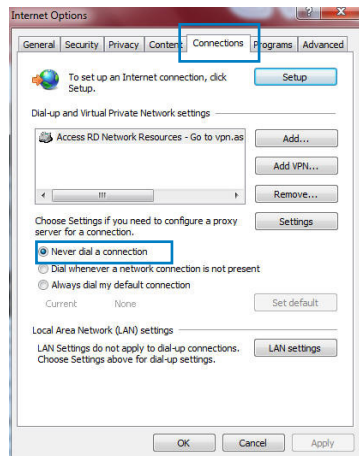

NOTE: Refer to your browser's help feature for details on disabling the dial-up connection.

3 Configuring via the web GUI

Logging into the web GUI

Your ASUS Wireless Router comes with an intuitive web graphics user interface (GUI) that allows you to easily configure its various features through a web browser such as Internet Explorer, Firefox, Safari, or Google Chrome.

To log into the web GUI:

1. On your web browser such as Internet Explorer, Firefox, Safari, or Google Chrome, manually key in the wireless router's default IP address: **192.168.1.1**
2. On the login page, key in the default user name (**admin**) and password (**admin**).



NOTES:

- For your network clients, ensure that you set the TCP/IP settings to obtain IP addresses automatically, disable the proxy server settings, disable the dial-up settings, and cancel the dial-up connection.
- For more details, refer to the section **Before you proceed** in this user manual.

3. The wireless router's web GUI launches. Use the web GUI to configure various wireless settings.

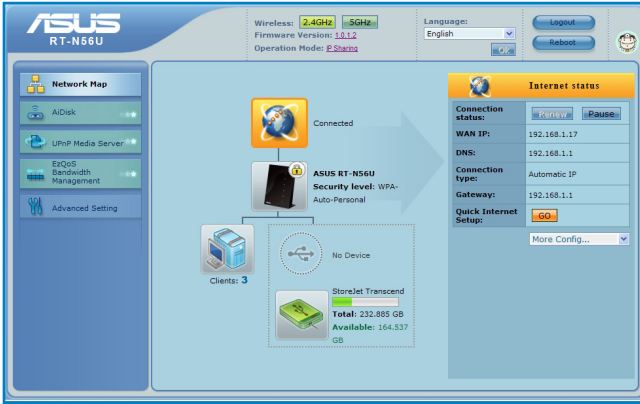

Setting up the Internet connection



NOTE: When setting the Internet connection **for the first time**, press the **Reset button** on your wireless router to reset it to its factory default settings.

Quick Internet Setup (QIS) with auto-detection

The Quick Internet Setup (QIS) function guides you in quickly setting up your Internet connection.

To use QIS with auto-detection:

1. Launch a web browser such as Internet Explorer, Firefox, Safari, or Google Chrome.

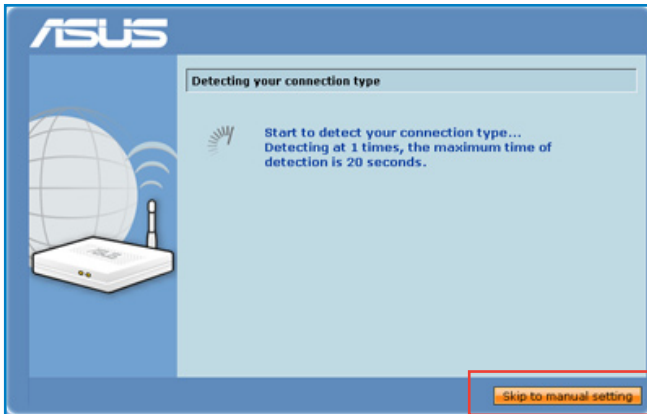

2. The wireless router automatically detects if your ISP connection type is **Dynamic IP**, **PPPoE**, **PPTP**, **L2TP**, and **Static IP**. Key in the necessary information for your ISP connection type.



IMPORTANT! Obtain the necessary information about your Internet connection type from your ISP.



NOTES:

- The **auto-detection** of your ISP connection type takes place when you configure the wireless router for the first time or when your wireless router is reset to its default settings.
- If QIS failed to detect your Internet connection type, click **Skip to manual setting** (see the screen capture in step 1) and manually configure your connection settings.
- If QIS failed to launch automatically, manually launch your wireless router's web GUI to access the QIS page. To do this, follow these steps:
 - On your web browser, key in **<http://192.168.1.1>**
 - On the login page, key in the default username **admin** and password **admin**.
 - Click **GO** in the **Quick Internet Setup** field under **Internet status** in the **Network Map** page.

3. Internet connection setup is done.

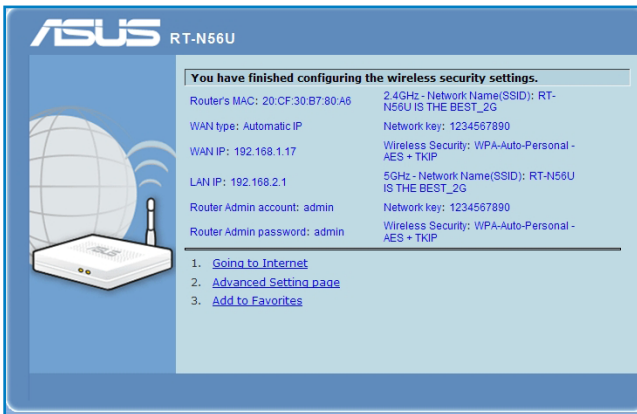

Select your next preferred task from any of these options:

1. **Going to Internet:** Click to start surfing the Internet or do Internet-related activities such as chat, or read/write e-mail messages.
2. **Advanced Setting page:** Click to go to the wireless router's Advanced Setting page and configure more advanced wireless settings.
3. **Add to Favorites:** Click to go add the router's web interface to your Favorites.

Using Wi-Fi Protected Setup (WPS)

WPS (Wi-Fi Protected Setup) allows you to set up a secure and protected wireless network easily.



NOTES:

- Ensure that you use a wireless LAN adapter with WPS function on your network clients.
- Windows® operating systems and wireless LAN cards/adapters that support WPS:

OS Support	Wireless Adapter Support
Windows Vista 32/64 Windows 7 32/64 Windows 2008	ASUS/Intel wireless LAN card (except WL-167g and WL-160W) ASUS WL-167g v2 driver v.3.0.6.0 or later ASUS WL-160N/WL-130N driver v.2.0.0.0 or later
Windows XP SP2/SP3 Windows 2003 32-bit SP2/SP3	ASUS/Intel wireless LAN card (not support WL-167g and WL-160W) ASUS WL-167g v2 driver v.1.2.2.0 or later ASUS WL-160N/WL-130N driver v.1.0.4.0 or later
Windows XP/2003 64-bit Windows XP 32-bit SP1/ XP 32-bit Windows 2003 32-bit SP1 / 2003 32-bit Windows 2000 SP4	ASUS wireless LAN card with ASUS WLAN Utility ASUS WL-167g v2 driver v.1.2.2.0 or later ASUS WL-160N/WL-130N driver v.1.0.4.0 or later

To use WPS:

1. In the **WPS** field, click the red button to launch the WPS Wizard.

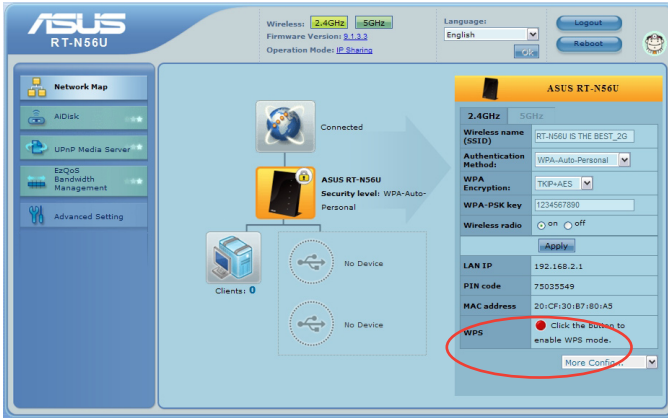

NOTE: You may also press the WPS button on your wireless router to launch the WPS Wizard.

2. Follow the onscreen instructions to complete the wireless network setup.



IMPORTANT! Obtain the necessary information about your Internet connection type from your ISP.

Setting up the wireless security settings

To protect your wireless network from unauthorized access, you need to configure its security settings.

To set up the wireless security settings:

1. Key in **192.168.1.1** on your web browser.
2. On the login screen, key in the default user name (**admin**) and password (**admin**), then click **OK**. The wireless router's web GUI launches.
3. On the **Network Map** screen, select the **System status** icon to display the wireless security settings such as SSID, security level, and encryption settings.



NOTE: You can set up different wireless security settings for 2.4GHz and 5GHz bands.

2.4GHz security settings

The screenshot shows the ASUS RT-N56U web interface. At the top, it displays 'ASUS RT-N56U' and 'Wireless: 2.4GHz | 5GHz'. The left sidebar contains navigation options: Network Map, AiDisk, UPnP Media Server, EQoS Bandwidth Management, and Advanced Setting. The main area shows a network diagram with a router icon labeled 'ASUS RT-N56U' and 'Security level: WPA-Auto-Personal'. Below the router, it indicates 'Clients: 3' and 'StoreJet Transcend' storage with 'Total: 232.885 GB' and 'Available: 164.537 GB'. On the right, the 'ASUS RT-N56U' configuration panel is open for the 2.4GHz band. It shows the following settings: Wireless name (SSID): RT-N56U IS THE BEST_2G; Authentication Method: WPA-Auto-Personal; WPA Encryption: TKIP+AES; WPA-PSK key: 1234567890; Wireless radio: on; LAN IP: 192.168.2.1; PIN code: 75032549; MAC address: 20:CF:3D:B7:80:A5; WPS: Click the button to enable WPS mode. There are 'Logout' and 'Reboot' buttons at the top right of the interface.

5GHz security settings

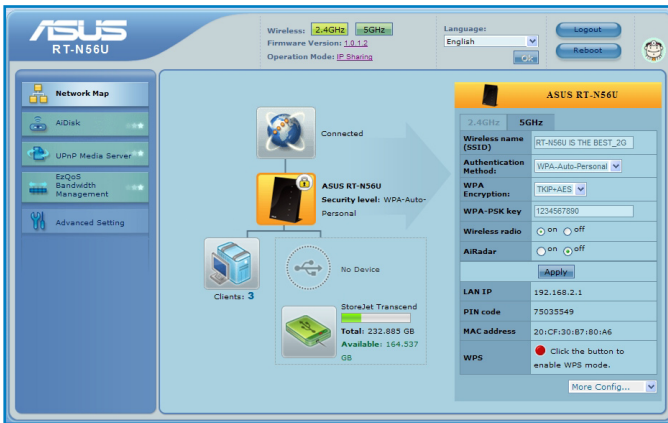

4. On the **Wireless name (SSID)** field, key in a unique name for your wireless network.
5. From the **Security Level** dropdown list, select the encryption method for your wireless network.



IMPORTANT! The IEEE 802.11n standard prohibits using High Throughput with WEP or WPA-TKIP as the unicast cipher. If you use these encryption methods, your data rate will drop to IEEE 802.11g 54Mbps connection.

6. Key in your security passkey.
7. Click **Apply** when done.

Managing your network clients

To manage your network clients:

1. Launch the wireless router's web GUI.
2. On the **Network Map** screen, select the **Client Status** icon to display the information about your network clients.

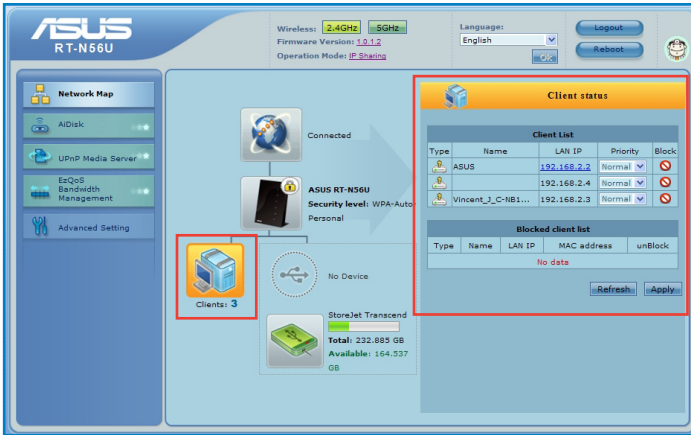

3. In the **Priority** field under the Client List, you can set the priority packet for each client as **Normal**, **High**, or **Low**.



NOTE: You can also delete the priority settings from **Advanced Setting > WAN > QoS** tab.

4. To block a client's access to your network, select the client and click **Block**.

To restore a client's access to your network, select the client in the **Blocked client list** and click **Unblock**.



NOTE: You can also delete the MAC filter from **Advanced Setting > Firewall > MAC Filter** tab.

Monitoring your USB device

The ASUS Wireless Router provides two USB 2.0 ports for connecting USB devices such as a USB storage device and USB printer, to allow you to monitor the working environment, share files, and printer with clients in your network.



NOTE: To use this feature, you need to plug a USB storage device, such as a USB hard disk or USB flash drive, to the USB 2.0 port on the rear panel of your wireless router. Ensure that the USB storage device is formatted and partitioned properly. Refer to the Plug-n-Share Disk Support List at <http://event.asus.com/networks/disksupport>



IMPORTANT! You first need to create a user account to allow other network clients to access the USB device. For more details, refer to the section **Sharing files from a USB storage device** in this user manual.

To monitor your USB device:

1. Launch the wireless router's web GUI.
2. On the **Network Map** screen, select the **USB Disk Status** icon to display the information about your USB device.

The screenshot displays the ASUS RT-N56U web GUI. The top navigation bar includes the ASUS logo, model name 'RT-N56U', and status indicators for Wireless (2.4GHz/5GHz), Firmware Version (1.0.1.2), and Operation Mode (P.Sharing). There are also buttons for Language (English), Logout, and Reboot. The main interface is divided into a left sidebar with 'Network Map', 'AiDisk', 'UPnP Media Server', 'EdgeS Bandwidth Management', and 'Advanced Setting'. The central area shows a 'Network Map' with a globe icon labeled 'Connected' and a router icon labeled 'ASUS RT-N56U Security level: WPA-Auto-Personal'. Below the router icon is a 'Clients: 3' indicator. A 'No Device' icon is also present. A red box highlights the 'External USB disk status' panel on the right, which shows details for a 'StoreJet Transcend' device: Model name: StoreJet Transcend, Total space: 232.885GB, Available space: 164.537GB, UPnP Media Server: GG, AiDisk Wizard: GG, and a 'Safely Remove disk:' button. Below this panel, a smaller red box highlights a 'StoreJet Transcend' icon with 'Total: 232.885 GB' and 'Available: 164.537 GB'.

3. On the **UPnP Media Server** field, click **GO** to allow UPnP (Universal Plug and Play) devices such as PS3 to access the multimedia files in your USB disk.



NOTE: For more details, refer to the next section **Using your router as a UPnP Media Server** in this user manual.

4. On the **AiDisk Wizard** field, click **GO** to set up an FTP server for Internet file sharing.



NOTES:

- For more details, refer to the section **Using AiDisk for an FTP Server and Network Neighborhood setup** in this user manual.
 - **On USB External HDD/Flash disk:**
 - The wireless router works with most USB HDDs/Flash disks (up to 2TB size) and supports read-write access for FAT16, FAT32, EXT2, EXT3, and NTFS.
 - To safely remove the USB disk, launch the web GUI (<http://192.168.1.1>), then in the **Network Map** page > **External USB disk status** > **Safely Remove disk** field, click **Remove**.
 - Incorrect removal of the USB disk may cause data corruption.
-

Using your router as a UPnP Media Server

Your wireless router allows UPnP (Universal Plug and Play) multimedia devices, such as PS3 and Xbox 360, to access multimedia files from the USB disk connected to your wireless router.



NOTE: Before using the UPnP Media Server function, install a wireless adapter on your UPnP device.

To use your router as a UPnP Server:

1. Click **UPnP Media Server** from the navigation menu at the left side of your screen.
2. Select **Enabled**. Your wireless router is now ready to share the media files stored in the USB disk.

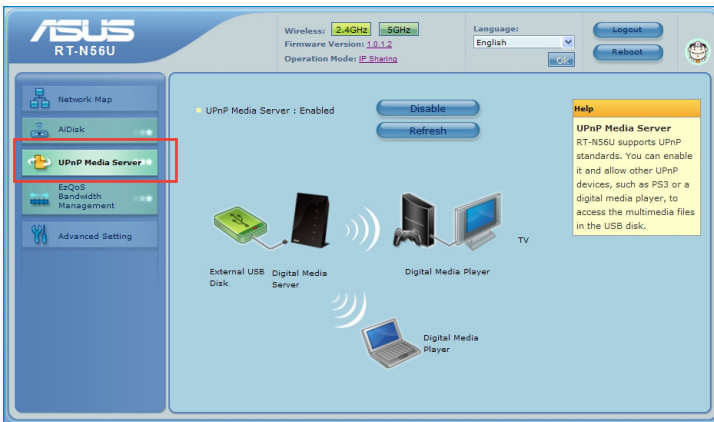

NOTE: For details on connecting a UPnP device to the wireless router and accessing the media files on the USB disk, refer to the UPnP device's user manual.



IMPORTANT! For details on sharing files/contents from a USB disk, refer to the section **Sharing files from a USB device** on this user manual.

Using AiDisk for an FTP Server and Network Neighborhood setup

AiDisk allows you to set up an FTP server and share the content of a USB disk to the clients in your network.



NOTE: Before using AiDisk, ensure that you have inserted a USB disk into the USB port of your wireless router.

To use AiDisk:

1. Click **AiDisk** from the navigation menu at the left side of your screen.
2. From the **Welcome to AiDisk wizard** screen, click **Go**.



3. Select the access rights that you want to assign to the clients accessing your shared data.

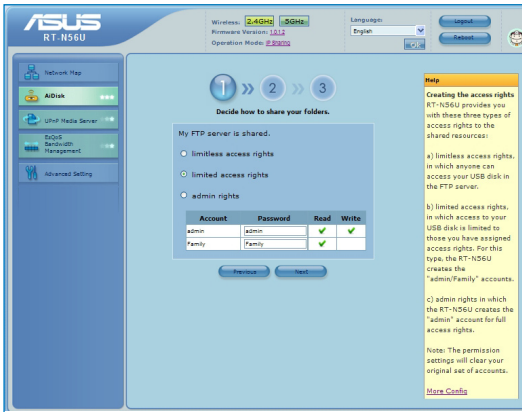

4. To create your own domain for your FTP site via the ASUS DDNS services, select **I will use the service and accept the Terms of service** and key in your domain name.
5. Click **Next** to finish the setup.

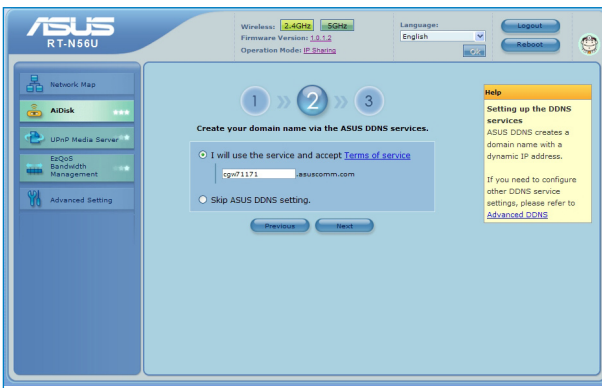

- When done, click **Finish**.
- To access the FTP site that you created, launch a web browser or a third-party FTP client utility and key in the ftp link (**ftp://<domain name>**) you have previously created.

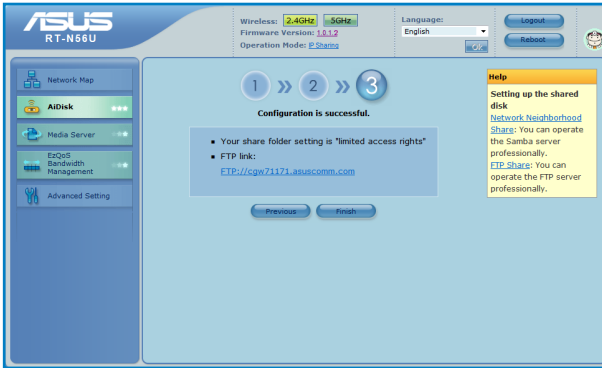

Managing EZQoS Bandwidth

EzQoS Bandwidth Management allows you to set the bandwidth priority and manage the network traffic.





To set up the bandwidth priority:

1. Click **EzQoS Bandwidth Management** from the navigation menu at the left side of your screen.



NOTE: Manually key in the uplink speed to prevent the router from detecting the wrong uplink speed from an unstable network.

2. Click each of these four applications to set the bandwidth priority:

Icon	Description
	Gaming Blaster The router handles gaming traffic at first priority.
	Internet Application The router handles the e-mail, web browsing and other Internet applications traffic at first priority.
	FTP The router handles at first priority the traffic of downloading/ uploading data to/from the FTP server.
	Voip/Video Streaming The router handles the audio/video traffic at first priority.

3. Click **Save** to save the configuration settings.

Configuring the Advanced settings

Advanced Setting allows you to configure the advanced features of your wireless router.



Setting up the DHCP Server

You may enable the **DHCP Server** function in your wireless router so your network clients can automatically obtain IP addresses from your wireless router.



NOTE: The ASUS Wireless Router can support up to 253 IP addresses for your network.

To set up the DHCP server:

1. Click **Advanced Setting** from the navigation menu at the left side of your screen.
2. Under the **LAN** menu, click **DHCP Server**.

LAN - DHCP Server	
RT-N56U supports up to 253 IP addresses for your local network. The IP address of a local machine can be assigned manually by the network administrator or obtained automatically from RT-N56U if the DHCP server is enabled.	
Enable the DHCP Server?	<input checked="" type="radio"/> Yes <input type="radio"/> No
RT-N56U's Domain Name:	<input type="text"/>
IP Pool Starting Address:	<input type="text" value="192.168.1.2"/>
IP Pool Ending Address:	<input type="text" value="192.168.1.254"/>
Lease Time:	<input type="text" value="86400"/>
Default Gateway:	<input type="text"/>

3. In the **Enable the DHCP Server?** field, tick **Yes**.
4. In the **IP Pool Starting Address** field, key in the starting IP address.
5. In the **IP Pool Ending Address** field, key in the ending IP address.
6. In the **Lease Time** field, key in the time that the IP addresses expire and the wireless router automatically assigns new IP Addresses for the network clients.



IMPORTANT!

- For the IP Pool Starting and Ending IP addresses, we recommend that you use:
 - **IP address:** 192.168.1.xxx (xxx can be any number between 2 and 254)
 - IP Pool Starting Address should not be greater than the IP Pool Ending Address.
-

Upgrading the firmware



NOTE: Download the latest firmware from the ASUS website at <http://www.asus.com>

To upgrade the firmware:

1. Click **Advanced Setting** from the navigation menu at the left side of your screen.
2. Under the **Administration** menu, click **Firmware Upgrade**.
3. In the **New Firmware File** field, click **Browse** to locate the new firmware on your computer.
4. Click **Upload**. The uploading process takes about three minutes.



NOTE: If the upgrade process fails, the wireless router automatically enters the rescue mode and the power LED indicator at the front panel flashes slowly. To recover or restore the system, use the Firmware Restoration utility.

Restoring/Saving/Uploading settings

To restore/save/upload the settings:

1. Click **Advanced Setting** from the navigation menu at the left side of your screen.

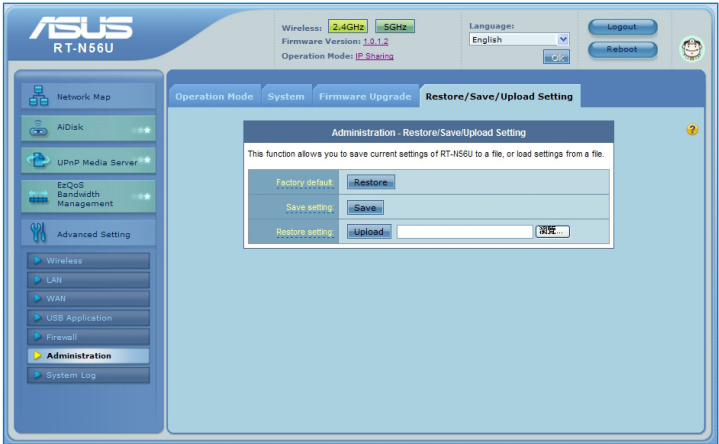

2. Under the Administration menu, click Restore/Save/Upload Setting.
3. Select the tasks that you want to do:
 - To restore to the default factory settings, click **Restore**, and click **OK** in the confirmation message.
 - To save the current system settings, click **Save**, and click **Save** in the file download window to save the system file in your preferred path.
 - To restore previous system settings, click **Browse** to locate the system file that you want to restore, then click **Upload**.

Sharing files from a USB storage device

Creating a user account

You need to create user accounts before you can share the files or data in the USB storage device.

To create a user account:

1. Click **Advanced Setting** > **USB Application** from the navigation menu at the left side of your screen.

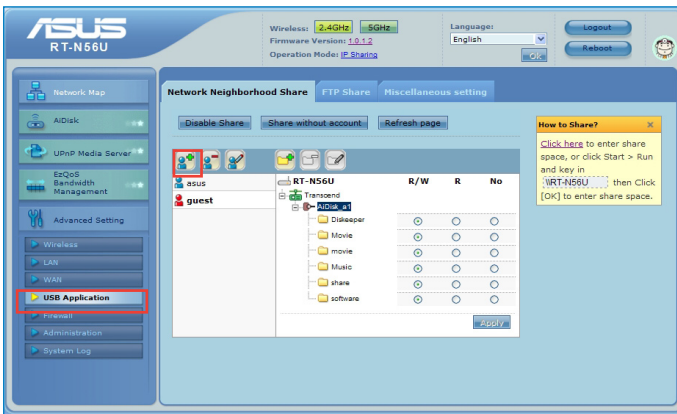

2. Click **Share with account**, and click **OK** to enable the sharing feature.
3. Click the Add account icon .

4. In the **Account** and **Password** fields, key in the name and password of the client/computer in your network. Retype the password to confirm. Click **Add** to add the account to the list.

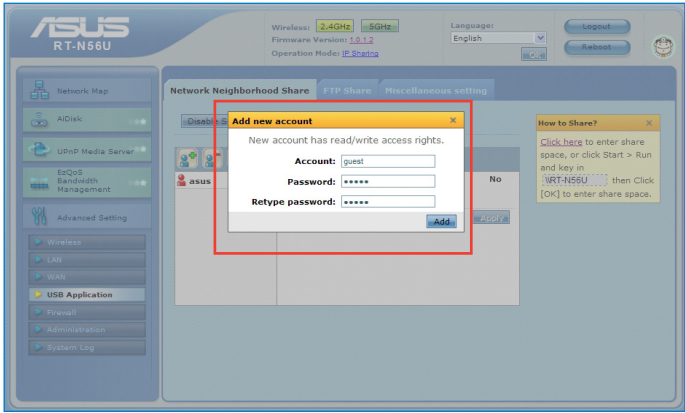

Assigning access rights

To assign access rights:

1. Click **Advanced Setting** > **USB Application** from the navigation menu at the left side of your screen.
2. Select the account that you want to assign access rights to.

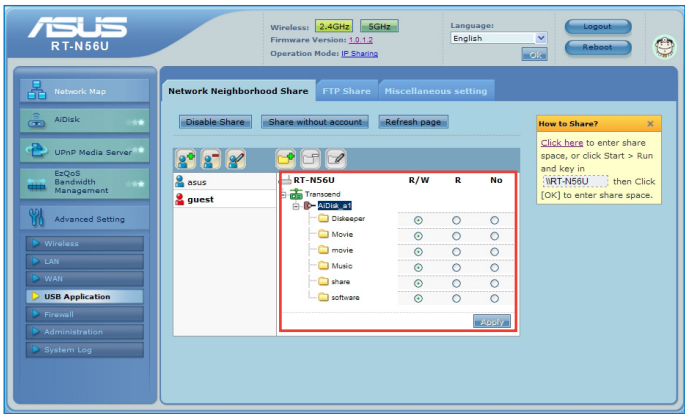

3. From the list of file folders, select the type of access rights that you want to assign for specific file folders:
 - **R/W**: Select this option to assign read/write access for a specific file folder.
 - **R**: Select this option to assign read only access for a specific file folder.
 - **No**: Select this option if you do not want to share a specific file folder.
4. Click **Apply** to apply the changes.
5. From the **Miscellaneous setting** tab, set the Work Group to **WORKGROUP** to enable all computers within **WORKGROUP** to access the wireless router's USB storage device.
6. Launch **My Network Place** from a computer connected to the wireless router. Click **view work group computers** to view the wireless router in the Workgroup category. All files on the USB storage device are now shared to computers in your network.

Sharing files via the FTP server

The ASUS Wireless Router enables you to share files from your USB storage device via the FTP server with computers in LAN or through the Internet.



IMPORTANT! To use this feature, you need to insert a USB storage device, such as a USB hard disk or USB flash drive, to the USB2.0 port on the rear panel of your wireless router. Ensure that the USB storage device is formatted and partitioned properly. Refer to the ASUS website at <http://www.asus.com> for the HD file system support table.



NOTE: Ensure that you safely remove the USB disk. Incorrect removal of the USB disk may cause data corruption.

To share files via the FTP server:

1. Ensure that you have set up your FTP server through AiDisk.



NOTE: For more details, refer to the section **Using AiDisk for an FTP Server and Network Neighborhood setup** in this user manual.

2. Enable the DDNS service for FTP server access. To do this, follow these steps:
 - a. From the navigation menu, click **Advanced > WAN > DDNS** tab.
 - b. In the **Enable the DDNS Client?** field, tick **Yes**.
 - c. Key in your **User Name or E-mail Address** and **Password or DDNS key**.
 - d. Key in your **Host name**. The format should be **xxx.asuscomm.com**, where xxx is your host name.
 - e. When done, click **Apply**.
3. From the navigation menu, click **Advanced Setting > USB Application > FTP Share** tab and select the account that you want to assign access rights to.

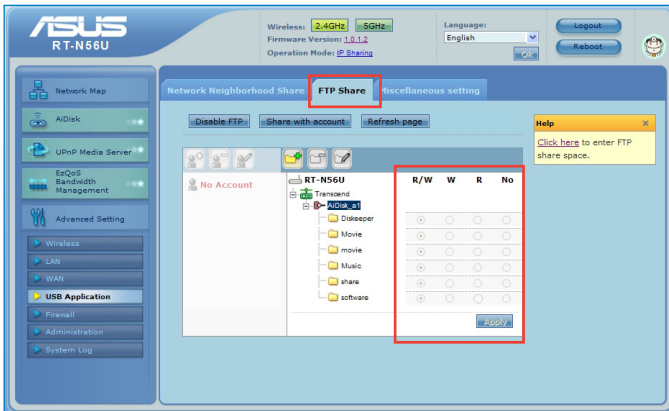

4. From the list of files/folders, select the type of access rights that you want to assign for specific files/folders:
 - **R/W**: Select this option to assign read/write access for a specific file/folder.
 - **W**: Select this option to assign write only access for a specific file/folder.
 - **R**: Select this option to assign read only access for a specific file/folder.
 - **No**: Select this option if you do not want to share a specific file/folder.
5. Click **Apply** to apply the changes.
6. To access the FTP server, key in the ftp link **ftp://<hostname>.asuscomm.com** and your user name and password on a web browser or a third-party FTP utility.

Setting up your network printer

Use the Network Printer Setup utility to set up a USB printer on your wireless router and allow network clients to access the USB printer.



NOTES:

- To check if your USB printer is compatible with your ASUS wireless router, refer to the Plug-n-Share Disk Support List at <http://event.asus.com/networks/disksupport>
- The wireless router's printer server function is not supported on Windows® 2000.

To set up your USB Printer:

1. Run the ASUS Wireless Utilities from the support CD, then click **Run Network Printer Setup Program**.

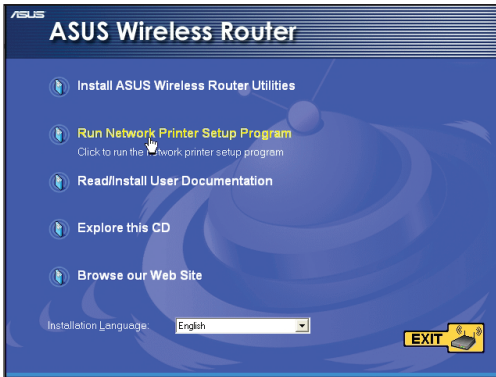

2. Follow the onscreen instructions to set up your hardware, then click **Next**.

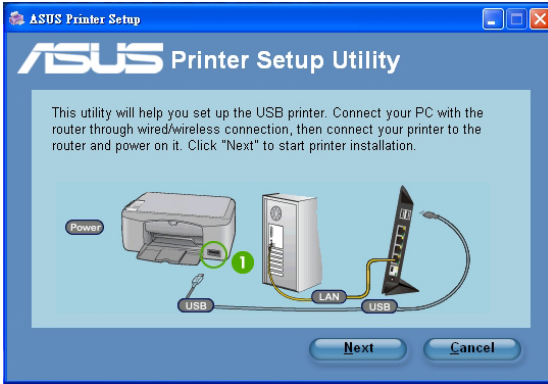

3. Wait for a few minutes for the initial setup to finish. Click **Next**.

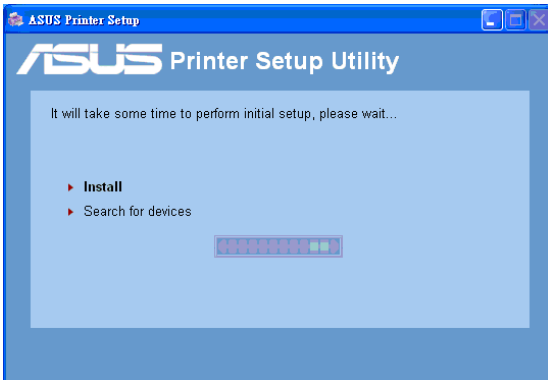

4. Click **Finish** to complete the installation.

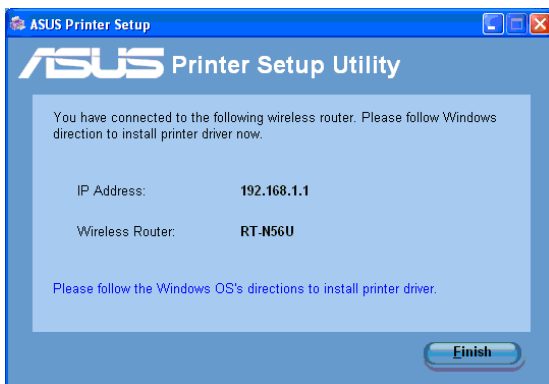

5. Follow the Windows® OS instructions to install the printer driver.



6. After the printer's driver installation is completed, network clients can now use the printer.

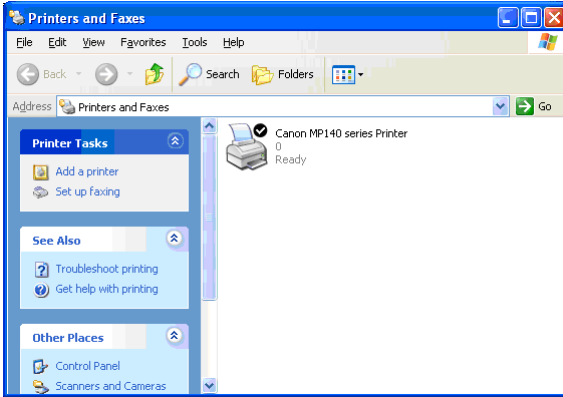

4 Using the utilities



NOTES:

- Install the wireless router's utilities from the bundled support CD.
- If Autorun is disabled, run **setup.exe** from the root directory of the support CD.

Device Discovery

Device Discovery is an ASUS WLAN utility that detects an ASUS wireless router device, and enables you to configure the device.

To launch the Device Discovery utility:

- From your computer's desktop, click **Start > All Programs > ASUS Utility > RT-N56U Wireless Router > Device Discovery**.

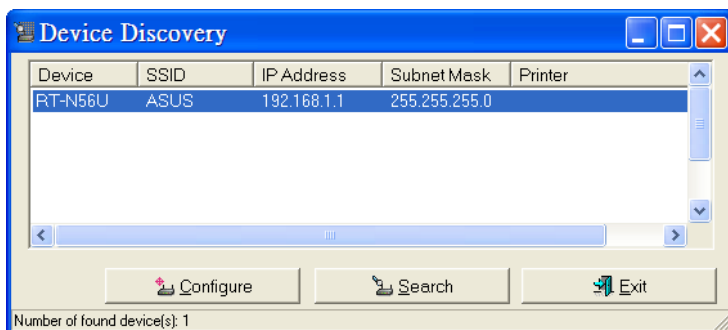

NOTE: When you set the router to Access Point mode, you need to use Device Discovery to get the router's IP address.

Firmware Restoration

Firmware Restoration is used on an ASUS Wireless Router that failed during its firmware upgrading process. It uploads the firmware that you specify. The process takes about three to four minutes.



IMPORTANT: Launch the rescue mode before using the Firmware Restoration utility.

To launch the rescue mode and use the Firmware Restoration utility:

1. Unplug the wireless router from the power source.
2. Hold the Reset button at the rear panel and simultaneously re-plug the wireless router into the power source. Release the Reset button when the Power LED at the front panel flashes slowly, which indicates that the wireless router is in the rescue mode.
3. Use the following to set up your TCP/IP settings:

IP address: 192.168.1.x

Subnet mask: 255.255.255.0

4. From your computer's desktop, click **Start > All Programs > ASUS Utility RT-N56U Wireless Router > Firmware Restoration.**

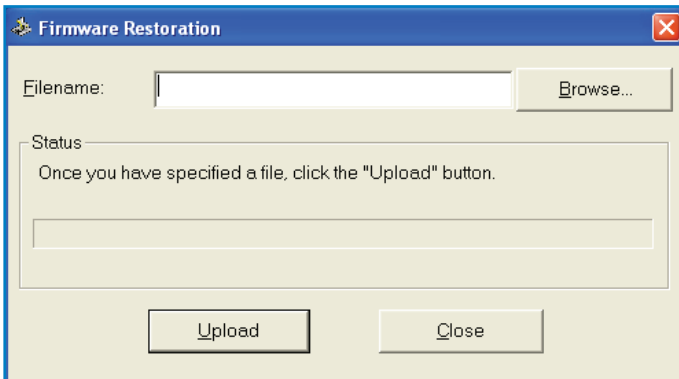

5. Specify a firmware file, then click **Upload**.



NOTE: This is not a firmware upgrade utility and cannot be used on a working ASUS Wireless Router. Normal firmware upgrades must be done through the web interface. Refer to **Chapter 3: Configuring via the web GUI** for more details.

Download Master

Download Master is a utility that allows you to organize your HTTP, FTP, and BT (BitTorrent) download tasks.

Using the Download Master



NOTE: To use this feature, you need to plug a USB storage device, such as a USB hard disk or USB flash drive, to the USB 2.0 port on the rear panel of your wireless router. Ensure that the USB storage device is formatted and partitioned properly. Refer to the ASUS website at <http://www.asus.com> for the HD file system support table.

To use the Download Master:

1. Launch the Download Master from **Start > All Programs > ASUS Utility > RT-N56U Wireless Router > Download Master**.
2. Click **File > Connect** to connect to the wireless router.

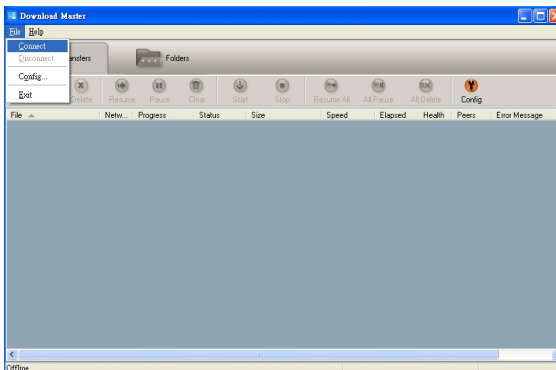

3. Follow the instructions below to organize the download tasks that you want to perform.

HTTP download

To perform an HTTP download, do any of the following:

- Right-click the download link on the web page and select **Download using ASUS Download**.
- Right-click the download link on the web page and select **Properties**. Copy the download Address (URL).



NOTES:

- If you select **Download using ASUS Download**, you can see the download task is added to the **Transfer** list. The blue bars indicate the progress rate of the download tasks.
 - If you copy the download address, click the **Assign** button in the utility. Paste the address into **Getting File From** box, select **HTTP** from **Options**, and click the **Download** button to start.
 - Ensure that you safely remove the USB disk. Incorrect removal of the USB disk may cause data corruption.
-

FTP download

Click the **Assign** button of the Download Master and select **FTP** in the **Options** field. Key in the FTP site address, Port number, User Name, Password. Click **Download** to start.



BT download

Save the BT seed on your computer. Click the **Assign** button of the Download Master and select **BT** in the **Options** field. Click **Browser** to locate the seed file and click Download to start.



3. Click the **Folder** button to view the download file. Open the **Complete** folder to view or copy the finished files to your local hard disk. The incomplete tasks are kept in the **InComplete** folder.

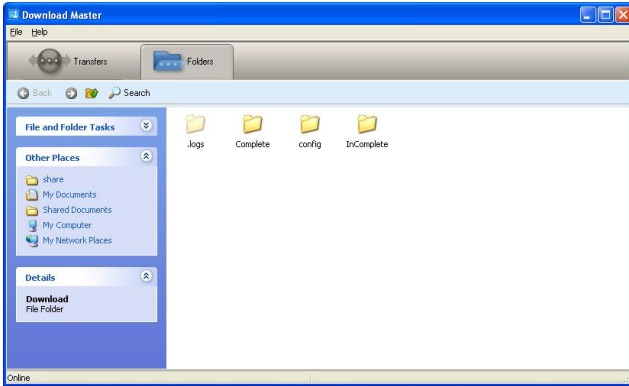

5 Troubleshooting



NOTE: If you encounter problems that are not mentioned in this chapter, contact the ASUS Technical Support.

Troubleshooting

I cannot access a web browser for configuring the router.

- Delete the cookies and files in your web browser. To do this, follow these steps:
 1. Launch your web browser, then click **Tools > Internet Options...**
 2. Under **Temporary Internet files**, click **Delete Cookies...** and **Delete Files...**



NOTE: The commands for deleting cookies and files vary with the web browser.

- Disable the proxy server settings, cancel the dial-up connection, and set the TCP/IP settings to obtain IP addresses automatically. For more details, refer to the section **Before you proceed** in this user manual.

The client cannot establish a wireless connection with the router.

Out of Range:

- Put the router closer to the wireless client.
- Try to change the channel settings.

Authentication:

- Use wired connection to connect to the router.
- Check the wireless security settings.
- Press the Reset button at the rear panel for more than five seconds.

Cannot find the router:

- Press the Reset button at the rear panel for more than five seconds.
- Check the setting in the wireless adapter such as SSID and encryption settings.

Cannot access the Internet via wireless LAN adapter.

- Move the router closer to the wireless client.
- Check whether the wireless adapter is connected to the correct wireless router.
- Check whether the wireless channel in use conforms to the channels available in your country/area.
- Check the encryption settings.
- Check if the ADSL or Cable connection is correct.
- Retry using another Ethernet cable.

Internet is not accessible.

- Check the status indicators on the ADSL modem and the wireless router.
- Check if the WAN LED on the wireless router is ON. If the LED is not ON, change the cable and try again.

When ADSL Modem “Link” light is ON (not blinking), this means Internet Access is possible.

- Restart your computer.
- Refer to the Quick Start Guide of the wireless router and re-configure the settings.
- Check if the WAN LED on the wireless router is ON.
- Check the wireless encryption settings.
- Check if the computer can get the IP address (via both wired network and wireless network).
- Ensure that your web browser is configured to use the local LAN, and is not configured to use a proxy server.

If the ADSL “LINK” light blinks continuously or stays off, Internet access is not possible - the Router is unable to establish a connection with the ADSL network.

- Ensure that all your cables are all properly connected .
- Disconnect the power cord from the ADSL or cable modem, wait a few minutes, then reconnect the cord.
- If the ADSL light continues to blink or stays OFF, contact your ADSL service provider.

Network name or encryption keys are forgotten.

- Try setting up the wired connection and configuring the wireless encryption again.
- Press the Reset button at the rear panel of the wireless router for more than five seconds.

How to restore the system to its default settings?

- Press the Reset button at the rear panel of the wireless router for more than five seconds.
- Refer to the section **Restoring/Saving/Uploading settings** in Chapter 3 of this user manual.

The following are the factory default settings:

User Name:	admin
Password:	admin
Enable DHCP:	Yes (if WAN cable is plugged in)
IP address:	192.168.1.1
Domain Name:	(Blank)
Subnet Mask:	255.255.255.0
DNS Server 1:	192.168.1.1
DNS Server 2:	(Blank)
SSID:	ASUS

ASUS DDNS Service

RT-N56U supports the ASUS DDNS service. When exchanging devices at the service center, if you have registered the ASUS DDNS service and want to keep the original domain name, data transfer is a must. Visit your local service center for more information.



NOTES:

- If there is no activity in the domain - such as reconfiguring the router or accessing the registered domain name - within 90 days, the system automatically deletes the registered information.
 - If you encounter any problem or difficulty in using your device, contact the service center.
-

Frequently Asked Questions (FAQs)

1. Will the registered information be lost or registered by others?

If you have not updated the registered information in 90 days, the system automatically deletes the registered information and the domain name may be registered by others.

2. I did not register the ASUS DDNS for the router I bought six months ago. Can I still register it?

Yes, you can still register the ASUS DDNS service for your router. The DDNS service is embedded in your router, so you can register the ASUS DDNS service anytime. Before registering, click **Query** to check if the hostname has been registered or not. If not, the system registers the hostname automatically.

3. I have registered a domain name before and it has been working well until my friends told me that they could not access my domain name.

Check the following:

1. The internet is working well.
2. The DNS server is working well.
3. The last time you updated the domain name.

If there are still problems in accessing your domain name, contact the service center.

4. Can I register two domain names to separately access my http and ftp servers?

No, you cannot. You can only register one domain name for one router. Use port mapping to implement security in the network.

5. After restarting the router, why is it that I see different WAN IPs in MS DOS and in the router configuration page?

This is normal. The interval time between the ISP DNS server and ASUS DDNS results in different WAN IPs in MS DOS and in the router configuration page. Different ISPs may have different interval time for IP updating.

6. Is the ASUS DDNS service free, or is it just a trial version?

The ASUS DDNS service is a free and embedded service in some ASUS routers. Check your ASUS router if it supports the ASUS DDNS service.

Appendices

Notices

ASUS Recycling/Takeback Services

ASUS recycling and takeback programs come from our commitment to the highest standards for protecting our environment. We believe in providing solutions for you to be able to responsibly recycle our products, batteries, other components, as well as the packaging materials. Please go to <http://csr.asus.com/english/Takeback.htm> for the detailed recycling information in different regions.

REACH

Complying with the REACH (Registration, Evaluation, Authorisation, and Restriction of Chemicals) regulatory framework, we published the chemical substances in our products at ASUS REACH website at <http://csr.asus.com/english/index.aspx>

Federal Communications Commission Statement

This device complies with Part 15 of the FCC Rules. Operation is subject to the following two conditions:

- This device may not cause harmful interference.
- This device must accept any interference received, including interference that may cause undesired operation.

This equipment has been tested and found to comply with the limits for a class B digital device, pursuant to part 15 of the FCC Rules. These limits are designed to provide reasonable

protection against harmful interference in a residential installation.

This equipment generates, uses and can radiate radio frequency energy and, if not installed and used in accordance with the instructions, may cause harmful interference to radio communications. However, there is no guarantee that interference will not occur in a particular installation. If this equipment does cause harmful interference to radio or television reception, which can be determined by turning the equipment off and on, the user is encouraged to try to correct the interference by one or more of the following measures:

- Reorient or relocate the receiving antenna.
- Increase the separation between the equipment and receiver.
- Connect the equipment into an outlet on a circuit different from that to which the receiver is connected.
- Consult the dealer or an experienced radio/TV technician for



IMPORTANT! This device within the 5.15 ~ 5.25 GHz is restricted to indoor operations to reduce any potential for harmful interference to co-channel MSS operations.



Caution: Any changes or modifications not expressly approved by the party responsible for compliance could void the user's authority to operate the equipment.

Prohibition of Co-location

This device and its antenna(s) must not be co-located or operating in conjunction with any other antenna or transmitter

Safety Information

To maintain compliance with FCC's RF exposure guidelines, this equipment should be installed and operated with minimum distance 20cm between the radiator and your body. Use on the supplied antenna.

Declaration of Conformity for R&TTE directive 1999/5/EC

Essential requirements – Article 3

Protection requirements for health and safety – Article 3.1a

Testing for electric safety according to EN 60950-1 has been conducted. These are considered relevant and sufficient.

Protection requirements for electromagnetic compatibility – Article 3.1b

Testing for electromagnetic compatibility according to EN 301 489-1 and EN 301 489-17 has been conducted. These are considered relevant and sufficient.

Effective use of the radio spectrum – Article 3.2

Testing for radio test suites according to EN 300 328- 2 has been conducted. These are considered relevant and sufficient.

CE Mark Warning

This is a Class B product, in a domestic environment, this product may cause radio interference, in which case the user may be required to take adequate measures.

NCC 警語

經型式認證合格之低功率射頻電機，非經許可，公司、商號或使用者均不得擅自變更頻率、

加大功率或變更原設計之特性及功能。

低功率射頻電機之使用不得影響飛航安全及干擾合法通信；經發現有干擾現象時，應立即

停用，並改善至無干擾時方得繼續使用。

前項合法通信，指依電信法規定作業之無線電通信。

低功率射頻電機須忍受合法通信或工業、科學及醫療用電波輻射性電機設備之干擾。

GNU General Public License

Licensing information

This product includes copyrighted third-party software licensed under the terms of the GNU General Public License. Please see The GNU General Public License for the exact terms and conditions of this license. We include a copy of the GPL with every CD shipped with our product. All future firmware updates will also be accompanied with their respective source code. Please visit our web site for updated information. Note that we do not offer direct support for the distribution.

GNU GENERAL PUBLIC LICENSE

Version 2, June 1991

Copyright (C) 1989, 1991 Free Software Foundation, Inc.

59 Temple Place, Suite 330, Boston, MA 02111-1307 USA

Everyone is permitted to copy and distribute verbatim copies of this license document, but changing it is not allowed.

Preamble

The licenses for most software are designed to take away your freedom to share and change it. By contrast, the GNU General Public License is intended to guarantee your freedom to share and change free software--to make sure the software is free for all its users. This General Public License applies to most of the Free Software Foundation's software and to any other program whose authors commit to using it. (Some other Free Software Foundation software is covered by the GNU Library General Public License instead.) You can apply it to your programs, too.

When we speak of free software, we are referring to freedom, not price. Our General Public Licenses are designed to make sure that you have the freedom to distribute copies of free software (and charge for this service if you wish), that you receive source code or can get it if you want it, that you can change the software or use pieces of it in new free programs; and that you know you can do these things.

To protect your rights, we need to make restrictions that forbid anyone to deny you these rights or to ask you to surrender the rights. These restrictions translate to certain responsibilities for you if you distribute copies of the software, or if you modify it.

For example, if you distribute copies of such a program, whether gratis or for a fee, you must give the recipients all the rights that you have. You must make sure that they, too, receive or can get the source code. And you must show them these terms so they know their rights.

We protect your rights with two steps: (1) copyright the software, and (2) offer you this license which gives you legal permission to copy, distribute and/or modify the software.

Also, for each author's protection and ours, we want to make certain that everyone understands that there is no warranty for this free software. If the software is modified by someone else and passed on, we want its recipients to know that what they have is not the original, so that any problems introduced by others will not reflect on the original authors' reputations.

Finally, any free program is threatened constantly by software patents. We wish to avoid the danger that redistributors of a free program will individually obtain patent licenses, in effect making the program proprietary. To prevent this, we have made it clear that any patent must be licensed for everyone's free use or not licensed at all.

The precise terms and conditions for copying, distribution and modification follow.

Terms & conditions for copying, distribution, & modification

0. This License applies to any program or other work which contains a notice placed by the copyright holder saying it may be distributed under the terms of this General Public License. The "Program", below, refers to any such program or work, and a "work based on the Program" means either the Program or any derivative work under copyright law: that is to say, a work containing the Program or a portion of it, either verbatim or with modifications and/or translated into another language. (Hereinafter, translation is included without limitation in the term "modification".) Each licensee is addressed as "you".

Activities other than copying, distribution and modification are not covered by this License; they are outside its scope. The act of running the Program is not restricted, and the output from the Program is covered only if its contents constitute a work based on the Program (independent of having been made by running the Program). Whether that is true depends on what the Program does.

1. You may copy and distribute verbatim copies of the Program's source code as you receive it, in any medium, provided that you conspicuously and appropriately publish on each copy an appropriate copyright notice and disclaimer of warranty; keep intact all the notices that refer to this License and to the absence of any warranty; and give any other recipients of the Program a copy of this License along with the Program.

You may charge a fee for the physical act of transferring a copy, and you may at your option offer warranty protection in exchange for a fee.

2. You may modify your copy or copies of the Program or any portion of it, thus forming a work based on the Program, and copy and distribute such modifications or work under the terms of Section 1 above, provided that you also meet all of these conditions:
 - a) You must cause the modified files to carry prominent notices stating that you changed the files and the date of any change.
 - b) You must cause any work that you distribute or publish, that in whole or in part contains or is derived from the Program or any part thereof, to be licensed as a whole at no charge to all third parties under the terms of this License.
 - c) If the modified program normally reads commands interactively when run, you must cause it, when started running for such interactive use in the most ordinary way, to print or display an announcement including an appropriate copyright notice and a notice that there is no warranty (or

else, saying that you provide a warranty) and that users may redistribute the program under these conditions, and telling the user how to view a copy of this License. (Exception: if the Program itself is interactive but does not normally print such an announcement, your work based on the Program is not required to print an announcement.)

These requirements apply to the modified work as a whole. If identifiable sections of that work are not derived from the Program, and can be reasonably considered independent and separate works in themselves, then this License, and its terms, do not apply to those sections when you distribute them as separate works. But when you distribute the same sections as part of a whole which is a work based on the Program, the distribution of the whole must be on the terms of this License, whose permissions for other licensees extend to the entire whole, and thus to each and every part regardless of who wrote it.

Thus, it is not the intent of this section to claim rights or contest your rights to work written entirely by you; rather, the intent is to exercise the right to control the distribution of derivative or collective works based on the Program.

In addition, mere aggregation of another work not based on the Program with the Program (or with a work based on the Program) on a volume of a storage or distribution medium does not bring the other work under the scope of this License.

3. You may copy and distribute the Program (or a work based on it, under Section 2) in object code or executable form under the terms of Sections 1 and 2 above provided that you also do one of the following:
 - a) Accompany it with the complete corresponding machine-readable source code, which must be distributed under the terms of Sections 1 and 2 above on a medium customarily used for software interchange; or,

- b) Accompany it with a written offer, valid for at least three years, to give any third party, for a charge no more than your cost of physically performing source distribution, a complete machine-readable copy of the corresponding source code, to be distributed under the terms of Sections 1 and 2 above on a medium customarily used for software interchange; or,
- c) Accompany it with the information you received as to the offer to distribute corresponding source code. (This alternative is allowed only for noncommercial distribution and only if you received the program in object code or executable form with such an offer, in accord with Subsection b above.)

The source code for a work means the preferred form of the work for making modifications to it. For an executable work, complete source code means all the source code for all modules it contains, plus any associated interface definition files, plus the scripts used to control compilation and installation of the executable. However, as a special exception, the source code distributed need not include anything that is normally distributed (in either source or binary form) with the major components (compiler, kernel, and so on) of the operating system on which the executable runs, unless that component itself accompanies the executable.

If distribution of executable or object code is made by offering access to copy from a designated place, then offering equivalent access to copy the source code from the same place counts as distribution of the source code, even though third parties are not compelled to copy the source along with the object code.

- 4. You may not copy, modify, sublicense, or distribute the Program except as expressly provided under this License. Any attempt otherwise to copy, modify, sublicense or distribute the Program is void, and will automatically terminate your rights under this License. However, parties who have received copies, or rights, from you under this License will not have their licenses terminated so long as such parties remain in full compliance.

5. You are not required to accept this License, since you have not signed it. However, nothing else grants you permission to modify or distribute the Program or its derivative works. These actions are prohibited by law if you do not accept this License. Therefore, by modifying or distributing the Program (or any work based on the Program), you indicate your acceptance of this License to do so, and all its terms and conditions for copying, distributing or modifying the Program or works based on it.
6. Each time you redistribute the Program (or any work based on the Program), the recipient automatically receives a license from the original licensor to copy, distribute or modify the Program subject to these terms and conditions. You may not impose any further restrictions on the recipients' exercise of the rights granted herein. You are not responsible for enforcing compliance by third parties to this License.
7. If, as a consequence of a court judgment or allegation of patent infringement or for any other reason (not limited to patent issues), conditions are imposed on you (whether by court order, agreement or otherwise) that contradict the conditions of this License, they do not excuse you from the conditions of this License. If you cannot distribute so as to satisfy simultaneously your obligations under this License and any other pertinent obligations, then as a consequence you may not distribute the Program at all. For example, if a patent license would not permit royalty-free redistribution of the Program by all those who receive copies directly or indirectly through you, then the only way you could satisfy both it and this License would be to refrain entirely from distribution of the Program.

If any portion of this section is held invalid or unenforceable under any particular circumstance, the balance of the section is intended to apply and the section as a whole is intended to apply in other circumstances.

It is not the purpose of this section to induce you to infringe any patents or other property right claims or to contest

validity of any such claims; this section has the sole purpose of protecting the integrity of the free software distribution system, which is implemented by public license practices. Many people have made generous contributions to the wide range of software distributed through that system in reliance on consistent application of that system; it is up to the author/donor to decide if he or she is willing to distribute software through any other system and a licensee cannot impose that choice.

This section is intended to make thoroughly clear what is believed to be a consequence of the rest of this License.

8. If the distribution and/or use of the Program is restricted in certain countries either by patents or by copyrighted interfaces, the original copyright holder who places the Program under this License may add an explicit geographical distribution limitation excluding those countries, so that distribution is permitted only in or among countries not thus excluded. In such case, this License incorporates the limitation as if written in the body of this License.
9. The Free Software Foundation may publish revised and/or new versions of the General Public License from time to time. Such new versions will be similar in spirit to the present version, but may differ in detail to address new problems or concerns.

Each version is given a distinguishing version number. If the Program specifies a version number of this License which applies to it and "any later version", you have the option of following the terms and conditions either of that version or of any later version published by the Free Software Foundation. If the Program does not specify a version number of this License, you may choose any version ever published by the Free Software Foundation.

10. If you wish to incorporate parts of the Program into other

free programs whose distribution conditions are different, write to the author to ask for permission.

For software which is copyrighted by the Free Software Foundation, write to the Free Software Foundation; we sometimes make exceptions for this. Our decision will be guided by the two goals of preserving the free status of all derivatives of our free software and of promoting the sharing and reuse of software generally.

NO WARRANTY

11 BECAUSE THE PROGRAM IS LICENSED FREE OF CHARGE, THERE IS NO WARRANTY FOR THE PROGRAM, TO THE EXTENT PERMITTED BY APPLICABLE LAW. EXCEPT WHEN OTHERWISE STATED IN WRITING THE COPYRIGHT HOLDERS AND/OR OTHER PARTIES PROVIDE THE PROGRAM "AS IS" WITHOUT WARRANTY OF ANY KIND, EITHER EXPRESSED OR IMPLIED, INCLUDING, BUT NOT LIMITED TO, THE IMPLIED WARRANTIES OF MERCHANTABILITY AND FITNESS FOR A PARTICULAR PURPOSE. THE ENTIRE RISK AS TO THE QUALITY AND PERFORMANCE OF THE PROGRAM IS WITH YOU. SHOULD THE PROGRAM PROVE DEFECTIVE, YOU ASSUME THE COST OF ALL NECESSARY SERVICING, REPAIR OR CORRECTION.

12 IN NO EVENT UNLESS REQUIRED BY APPLICABLE LAW OR AGREED TO IN WRITING WILL ANY COPYRIGHT HOLDER, OR ANY OTHER PARTY WHO MAY MODIFY AND/OR REDISTRIBUTE THE PROGRAM AS PERMITTED ABOVE, BE LIABLE TO YOU FOR DAMAGES, INCLUDING ANY GENERAL, SPECIAL, INCIDENTAL OR CONSEQUENTIAL DAMAGES ARISING OUT OF THE USE OR INABILITY TO USE THE PROGRAM (INCLUDING BUT NOT LIMITED TO LOSS OF DATA OR DATA BEING RENDERED INACCURATE OR LOSSES SUSTAINED BY YOU OR THIRD PARTIES OR A FAILURE OF THE PROGRAM TO OPERATE WITH ANY OTHER PROGRAMS), EVEN IF SUCH HOLDER OR OTHER PARTY HAS BEEN ADVISED OF THE POSSIBILITY OF SUCH DAMAGES.

ASUS Contact information

ASUSTeK COMPUTER INC. (Asia Pacific)

Address 15 Li-Te Road, Peitou, Taipei, Taiwan 11259
Website www.asus.com.tw

Technical Support

Telephone +886228943447
Support Fax +886228907698
Online support support.asus.com

ASUS COMPUTER INTERNATIONAL (America)

Address 800 Corporate Way, Fremont, CA 94539, USA
Telephone +15107393777
Fax +15106084555
Website usa.asus.com
Online support support.asus.com

ASUS COMPUTER GmbH (Germany and Austria)

Address Harkort Str. 21-23, D-40880 Ratingen, Germany
Telephone +491805010923*
Fax +492102959911
Website www.asus.de
Online contact www.asus.de/sales

Technical Support

Telephone (Component, Networking) +491805010923*
Telephone (System/Notebook/Eee/LCD) +491805010920*
Fax +492102959911
Online support support.asus.com

* EUR 0.14/minute from a German fixed landline; EUR 0.42/minute from a mobile phone.

Networks Global Hotline Information

Area	Hotline Number	Support Languages	Working Hour	Working Day
Australia	1300-2787-88	English	9:00-18:00	Mon. to Fri.
Austria	0043-820240513	German	9:00-18:00	Mon. to Fri.
Belgium	0032-78150231	Dutch /French	9:00-17:00	Mon. to Fri.
China	800-820-6655; 021-34074610	Simplified Chinese	9:00-18:00	Mon. to Sun.
Denmark	0045-3832-2943	Denish/English	9:00-17:00	Mon. to Fri.
Finland	00358-9693-7969	Finnish/English/ Swedish	10:00-18:00	Mon. to Fri.
France	0033-170949400	France	9:00-17:45	Mon. to Fri.
Greece	00800-44-14-20-44	Greek	9:00-13:00; 14:00-18:00	Mon. to Fri.
Hong Kong	3582-4770	Cantonese/ Chinese/ English	10:00-20:00	Mon. to Fri.
			10:00-17:00	Sat.
Ireland	0035-31890719918	English	9:00-17:00	Mon. to Fri.
Japan	0800-123-2787	Japanese	9:00-18:00	Mon. to Fri.
			9:00-17:00	Sat. to Sun.
Malaysia	+603 2148 0827 (Check Repair Detail Status Only) +603-6279-5077	Bahasa Melayu/ English	10:00-19:00	Mon. to Fri.
Netherlands / Luxembourg	0031-591-570290	Dutch / English	9:00-17:00	Mon. to Fri.
New Zealand	0800-278-788 / 0800-278-778	English	9:00-17:00	Mon. to Fri.
Norway	0047-2316-2682	Norwegian /English	9:00-17:00	Mon. to Fri.
Philippine	+632-636 8504; 180014410573	English	9:00-18:00	Mon. to Fri.
Poland	00225-718-033 00225-718-040	Polish	9:00-17:00	Mon. to Fri.
			8:30-17:30	
Portugal	707-500-310	Portuguese	9:00-17:00	Mon. to Fri.

Networks Global Hotline Information

Area	Hotline Number	Support Languages	Working Hour	Working Day
Russia	+8-800-100-ASUS; +7-495-231-1999	Russian/ English	9:00-18:00	Mon. to Fri.
Singapore	+65-6720-3835 (Check Repair Detail Status Only) -66221701	English	11:00-19:00	Mon. to Fri.
Slovak	00421-232-162-621	Czech	8:00-17:00	Mon. to Fri.
Spain	902-88-96-88	Spanish	9:00-18:00	Mon. to Fri.
Sweden	0046-8587-6940	Swedish/ English	9:00-17:00	Mon. to Fri.
Switzerland	0041-848111010	German/French	9:00-18:00	Mon. to Fri.
	0041-848111014	French	9:00-17:45	Mon. to Fri.
	0041-848111012	Italian	9:00-17:00	Mon. to Fri.
Taiwan	0800-093-456; 02-81439000	Traditional Chinese	9:00-12:00; 13:30-18:00	Mon. to Fri.
Thailand	+662-679-8367 -70; 001 800 852 5201	Thai/English	9:00-18:00	Mon. to Fri.
Turkey	+90-216-524-3000	Turkish	09:00-18:00	Mon. to Fri
United Kingdom	0044-870-1208340; 0035-31890719918	English	9:00-17:00	Mon. to Fri.
USA/Canada	1-812-282-2787	English	8:30- 12:00am EST (5:30am- 9:00pm PST) 9:00am- 6:00pm EST (6:00am- 3:00pm PST)	Mon. to Fri. Sat. to Sun.



NOTE: For more information, visit the ASUS support site at:
<http://support.asus.com>

Manufacturer:	ASUSTeK Computer Inc. Tel: +886-2-2894-3447 Address: No. 150, LI-TE RD., PEITOU, TAIPEI 112, TAIWAN
Authorised representative in Europe:	ASUS Computer GmbH Address: HARKORT STR. 21-23, 40880 RATINGEN, GERMANY
Authorised distributors in Turkey:	BOGAZICI BIL GISAYAR SAN. VE TIC. A.S. Tel: +90 212 3311000 Address: AYAZAGA MAH. KEMERBURGAZ CAD. NO.10 AYAZAGA/ISTANBUL
	CIZGI Elektronik San. Tic. Ltd. Sti. Tel: +90 212 3567070 Address: CEMAL SURURI CD. HALIM MERIC IS MERKEZI No: 15/C D:5-6 34394 MECIDIYEKOY/ISTANBUL

EEE Yönetmeliğine Uygundur.