

ATOMIC

**Quick
Set-Up Guide**

ADVW721 (RF8338-51)

900MHz

**PLL Headphones
Manual Tuning**

Congratulations on the purchase of **ADVW721 (RF8338-51)** (900MHz) Stereo RF Wireless Headphones to enjoy the revolutionary technology of **Phase Lock Loop (PLL)**! Please check the supplied component against the following list:

- 1 x Transmitter
- 1 x Headphones
- 1 x Power Supply (AC/DC 12V 200mA Adaptor for Transmitter)
- 1 x 3.5mm Stereo Audio Cord
- 1 x 3.5mm Y-connection Cord
- 1 x Charging Cord

FUNCTION KEYS

HEADPHONES

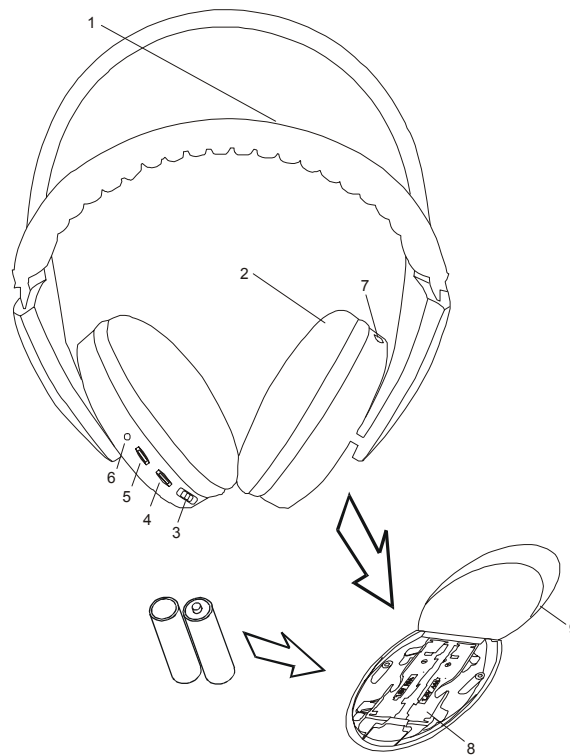

- (1) Headbelt
- (2) Ear Cushion
- (3) Power ON/OFF Switch
- (4) Channel Tuning Knob
- (5) Volume Control Knob
- (6) Power LED Indicator
- (7) Charging Socket
- (8) Battery Compartment
- (9) Battery cover

TRANSMITTER:

Transmitter Front Side:

(10) Charging LED Indicator

(11) Power LED Indicator

Transmitter Rear Side:

(12) Channel CH1/CH2/CH3 Switch

(13) Audio IN Socket

(14) Charging Socket

(15) DC IN Socket

ACCESSORIES:

(16) 3.5mm Y-connection Cord

(17) 3.5mm Stereo Audio Cord

(18) AC/DC Adaptor

(19) Charging Cord

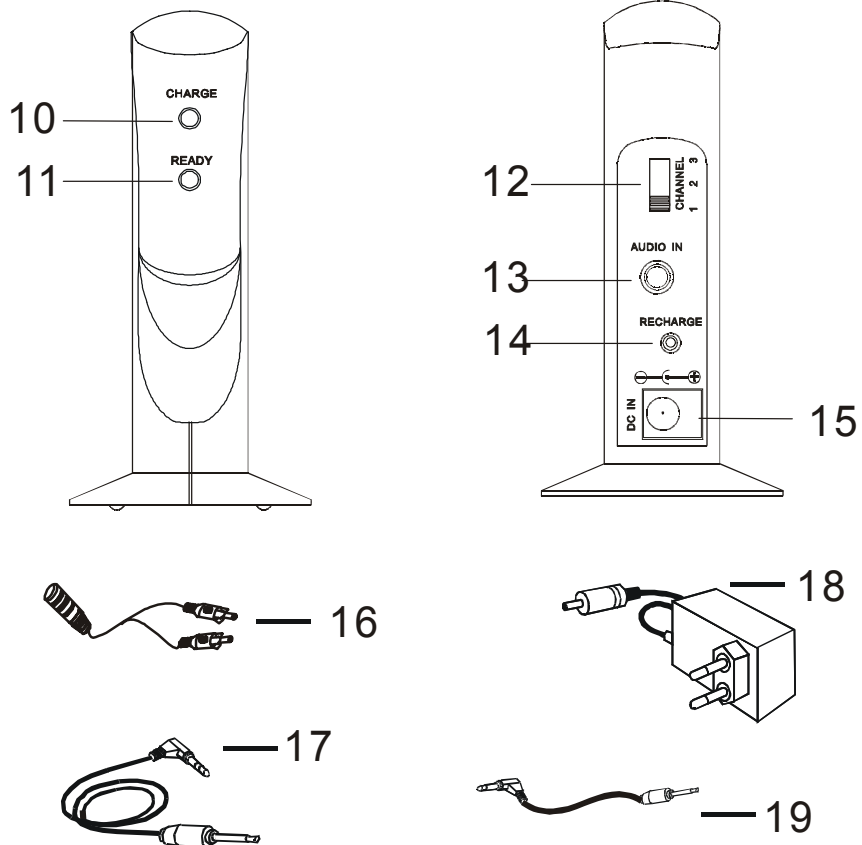

INSTALLATION

Please follow this quick set-up guide to ensure trouble free installation of your headphones.

Step 1:

Connect the 3.5mm Stereo Audio Cord (17) to the audio output socket (i.e. PHONE/ HEADPHONE 3.5mm socket) of your audio source, e.g. TV, HiFi, CD, DVD player etc.

**** If your audio source has 2 RCA output sockets (red and white in colour), use the 90mm Y-connection Cord (16) for connection, if necessary.*

Step 2:

Connect the other end of the 3.5mm Stereo Audio Cord (17) to the Audio IN Socket (13) at the rear side of the transmitter.

Step 3:

Connect one end of the AC/DC Adaptor (18) to the DC IN Socket (15) at the rear side of the transmitter, and the other end to the main electric wall outlet.

Step 4:

The transmitter will be automatically ON when there is audio signal from the audio source (please make sure that the transmitter is powered on by the AC/DC adaptor in Step 3). Then the Power LED Indicator (11) will glow Green to confirm that the transmitter is ready for operation. Place the transmitter on a dry, cool place preferably above head level.

**** The transmitter has auto-cut-off function. When there is no audio signal for over 70+/-10 seconds, the power of the transmitter will be automatically cut off.*

Step 5:

Open the Battery Cover (9). Insert 2 pcs AAA size batteries into the Battery Compartment (8) at the Left hand side of the headphones observing the correct polarity. Then close the Battery Cover (9), and switch the headphones ON (3).

Step 6:

Switch on your music device (TV, HiFi, CD, DVD etc.) and start your media playing.

Step 7:

Adjust the channel Tuning Knob (4) Select the Correct channel and The good quality sound. Adjust the Volume Control Knob (5) to a comfortable sound level.

CHANNEL SELECTION

There are 3 channels altogether for this PLL Headphone. At the rear side of the transmitter, there is a Channel CH1/CH2/CH3 Switch (12).

Frequency	Channel
912.40MHz	CH1
913.00MHz	CH2
913.60MHz	CH3

The 3 different channels are auto-locked by the latest PLL technology, enable you to enjoy the great sound quality in high stability.

CHARGING THE HEADPHONES

Battery type: Rechargeable batteries AAA
No. of cells: 2pcs
Rated capacity: 300 mAH / 9 hrs
Rated DC output voltage (V): 2.4V
Rated DC output current (A): 60mA

Step 1:

Insert 2 pcs AAA size rechargeable batteries into the Battery Compartment (8) at the Left hand side of the headphones.

Step 2:

Switch OFF (3) the headphones.

Step 3:

Connect the transmitter to a conveniently located electric wall outlet with the supplied AC/DC Adaptor (18).

Step 4:

Insert one end of the Charging Cord (19) to the Charging Socket (14) at the rear side of transmitter and the other end to the Charging Socket (7) of headphones.

The batteries should be charged for a full 12 hours before use. During charging process, the Charging LED Indicator (10) will glow RED showing the headphone is being charged.

****** Regular (non-rechargeable type) batteries can also be used to operate this headphone. However, you must never attempt to charge non-rechargeable batteries in this appliance as this could prove dangerous.***

Step 5:

When the batteries have been charged, remember to remove the Charging Cord from the headphones.

*** Charging procedure should never exceed 48 hours.

Caution! To avoid risk of fire or injury, do not attempt to recharge non-rechargeable batteries.

Replace only with the same or equivalent type recommended by the manufacturer. Please dispose of old, defective batteries in an environmentally friendly manner in accordance with the relevant legislation.

TROUBLE SHOOTING GUIDE

If you encounter any trouble in setting up the Headphones, please check the following points:

(1) Distorted sound quality or unclear sound:

- ~ Check if the sound of your audio source is distorted and whether the volume control is tuned to the suitable level.
- ~ Check if the batteries in the headphones have insufficient power. Replace fresh ones if necessary.
- ~ Check if you have selected the best channel, Turn the Channel Tuning Knob (4) again to check.
- ~ Check if the distance between the headphones and transmitter are within the effective range. (The effective range of the device is approx. 100M in open area.) Place the headphones closer to the transmitter.

(2) No Sound from the headphones:

- ~ Make sure that your audio equipment, the transmitter and headphones are properly connected, powered and switched ON.
- ~ Check if the batteries are inserted properly into the battery compartment.
- ~ Check if the transmitter is powered on with the AC/DC adaptor: the Power LED Indicator (11) will glow GREEN showing the transmitter is powered (only when there is audio signal from the audio source).
- ~ Check if all the connection cords are properly connected.

(3) Mono Sound:

- ~ Check if the audio source is mono only, use stereo audio source.

(4) Interference:

- ~ At the rear side of the transmitter, there is a Channel CH1/CH2/CH3 Switch (12), select a different channel and adjust the Channel Tuning Knob (4) Select the Correct channel and The good quality sound.

(5) Power auto-cut-off:

- ~ The transmitter has auto-cut-off function. When there is no audio signal for a prolonged period, the power of the transmitter will be automatically cut off. You just need to switch on the audio sources again.

The ventilation should not be impeded by covering the ventilation openings with items, such as newspaper, tablecloths, curtains, etc.

No naked flame sources, such as lighted candles, should be placed on the apparatus.

If you still have problem after checking the above points, please contact your customer service. Do not try to loosen the screws of the products to fix the problem.

*All the above are subject to our final change without further notice.
Copyright by Atom Industrial Ltd.2003*

SPECIFICATION

Model	ADVW721 (RF8338-51) (900MHz)
Description	Radio Frequency (UHF) Wireless Headphones System (Power Auto Cut Off/ Phase Lock Loop/ Rechargeable function)
<u>Transmitter</u>	
No. of Channels	3
Carrier Frequency	Channel 1: 912.40MHz Channel 2: 913.00MHz Channel 3: 913.60MHz
Effective Range	100 meters
Power Supply	AC/DC Adaptor
<u>Headphones</u>	
Frequency Responses	20 - 20,000 Hz
Signal to Noise Ratio	50dB
Distortion	<1%
Channel Separation	30dB
Power Supply	2 x 1.2V AAA size rechargeable batteries OR 2 x 1.5V AAA size normal batteries (Optional)
System Included:	1 x Transmitter 1 x Headphones 1 x AC120V DC 12V 200mA (UL) adaptor for transmitter 1 x 3.5mm Stereo Audio Cord 1 x 3.5mm Y-connection Cord 1 x Charging Cord

Operation is subject to the following two conditions: (1) this device may not cause interference, and (2) this device must accept any interference, including interference that may cause undesired operation of the device.

Warning: Changes or modifications to this unit not expressly approved by the party responsible for compliance could void the user's authority to operate the equipment.