

INSTALLATION AND OWNER'S MANUAL

AUD-S

AU SERIES WITH SOLID STATE CONTROL CIRCUITRY
DRAWBAR COMMERCIAL VEHICULAR DOOR
OPERATORS

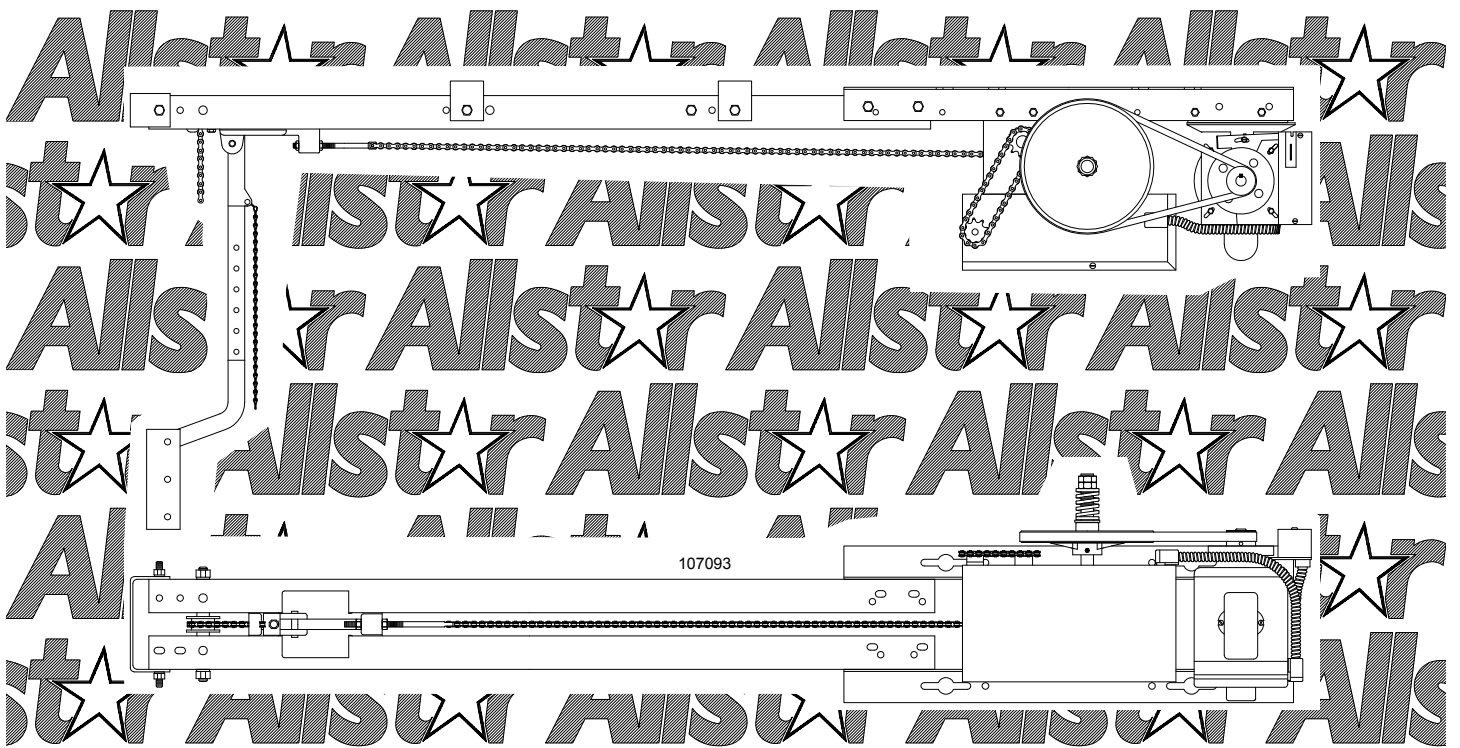

As of date of manufacture,
meets all ANSI/UL 325
Safety Requirements for
Vehicular door operators

Serial #:
Date Installed:
Your Dealer:

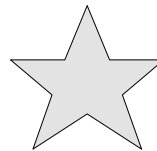

**READ THIS MANUAL
CAREFULLY BEFORE
INSTALLATION OR USE**

SAVE THESE INSTRUCTIONS !





Description	Page
Model AUD-S Drawbar Operator Features.....	3
Model AUD-S Applications	3
Preparation	4
Figure 1 - Component Identification Pictorial (Unpacking).....	4
Important Installation Warnings (Things To Do Before & During Installation).....	5
Table 1 - Component Identification Listing	5
Rail/Chain Assembly Instructions	6
Installation Instructions.....	7-12
Electrical Wiring Instructions.....	10
Pneumatic Door Edge Installation	11
Field Wiring	11 & 12
Turning on Power to the Operator	12
Operation and Adjustment Instructions	13-19
Important Safety Instructions for Owner.....	13
Setting the Switch Selectable Operating Modes.....	14
Set-Up Operating Characteristics Instructions`	15
Brake Adjustment	16
Setting The Limits	17
Clutch Adjustment	18
Testing	19
Maintenance	19
Wiring Diagrams/Schematics (Single & Three Phase)	20 & 21
Operator Dimensions.....	22
Parts Identification.....	23
Operator Specifications.....	24
Warranty	24

READ THESE STATEMENTS CAREFULLY AND FOLLOW THE INSTRUCTIONS CLOSELY.



The Warning and Caution boxes throughout this manual are there to protect you and your equipment. Pay close attention to these boxes as you follow the manual.

 <p>WARNING</p>
<p>Indicates a MECHANICAL hazard of INJURY OR DEATH. Gives instructions to avoid the hazard.</p>

 <p>CAUTION</p>
<p>Indicates a MECHANICAL hazard of DAMAGE to your operator or equipment. Gives instructions to avoid the hazard.</p>

 <p>WARNING</p>
<p>Indicates an ELECTRICAL hazard of INJURY OR DEATH. Gives instructions to avoid the hazard.</p>

 <p>CAUTION</p>
<p>Indicates an ELECTRICAL hazard of DAMAGE to your operator or equipment. Gives instructions to avoid the hazard.</p>



The **purpose** of this booklet is to provide assembly, installation and operation information concerning the Model AUD-S Commercial Vehicular Garage Door Operators and related Accessory Products.

NOTICE

IT IS IMPORTANT THAT THIS INSTRUCTION MANUAL BE READ AND UNDERSTOOD COMPLETELY BEFORE INSTALLATION OR OPERATION IS ATTEMPTED. IT IS INTENDED THAT THE INSTALLATION OF THIS UNIT WILL BE DONE ONLY BY PERSONS TRAINED AND QUALIFIED IN THE INSTALLATION, ADJUSTMENT AND SERVICE OF COMMERCIAL OVERHEAD DOORS AND DOOR OPERATORS AND BY QUALIFIED ELECTRICIANS.

NOTICE

THE IMPORTANT SAFEGUARDS AND INSTRUCTIONS IN THIS MANUAL CANNOT COVER ALL POSSIBLE CONDITIONS AND SITUATIONS WHICH MAY OCCUR DURING ITS USE. IT MUST BE UNDERSTOOD THAT COMMON SENSE AND CAUTION MUST BE EXERCISED BY THE PERSON (S) INSTAL- LING, MAINTAINING AND OPERATING THE EQUIPMENT DESCRIBED HEREIN. DO NOT USE THIS EQUIPMENT FOR ANY OTHER THAN ITS INTENDED PURPOSE - OPERATING OVERHEAD COMMERCIAL VEHICULAR GARAGE DOORS.

STANDARD FEATURES:

Solid State Controls: The openers employ solid state technology with advanced standard features to provide for a complete commercial door operating system.

Switch Selectable Operating Modes: Six distinct base operation modes can be selected by resetting the switches on the motor control board: a standard Open, Close, Stop (B2, momentary button push); three constant pressure modes (C2, D1, and E2); two Timer to Close modes (T and TS). See page 14 for complete description of the modes.

Switch Selectable Characteristic Modes: Five different operating characteristics can be activated and/or modified through the switches on the motor control board: Delay On Reverse, Close Limit Delay, Mid Stop Travel, Timer to Close, Maximum Run Timer.

Limit Switches: Driven limit switches, easily adjusted over a wide range. The motor may be removed without affecting the limit switch adjustments

Manual Release: Permits manual operation of the door in the event of a power failure.

Control Circuit: Standard three button open, close and stop. 5 Volts DC.

Connections For Auxiliary Entrapment Protection Devices: Use with foam or pneumatic reversing door edge components or a photoelectric beam (across the opening).

MODEL AUD-S OPERATOR APPLICATIONS:

Drawbar operators are for commercial and industrial use on sectional overhead doors which use horizontal track with normal radius. A draw bar operator is not suitable for doors with high lift exceeding 24 inches or vertical lift doors. The installation requires a minimum clearance of 5 inches above the high arc of the door (the highest point reached by the door at any part of its travel). For back-room requirement refer to **Figure 24, Page 22**. When properly installed a drawbar operator effectively locks the door in the closed position.

The Model AUD drawbar operators are used in the following applications:

- Continuous Duty, Medium Cycle Commercial installations only
- Indoor Use Only
- Up to 22 foot high doors with a maximum area of 480 square feet for 3/4 HP, 280 square feet for 1/2 HP and 200 square feet for 1/3 HP - maximum area slightly higher for lighter doors - consult factory
- Use with foam or pneumatic reversing edge door components - **REQUIRED** where the 3 button station is out of sight of the door or any other automatic, remote or manual control is used to activate the door.

OPTIONAL FEATURES:

Digital Radio Controls: Open, Close and Stop operation. Radio units are available to control up to 27 doors from one transmitter

Keyless Entry System: Connection terminals provided for hard wired or wireless keyless entry system.

Brake: Optional on 1/3 & 1/2HP, Standard on 3/4 HP. Can be added in the field.



WARNING

ELECTRIC DOOR OPENERS ARE DESIGNED FOR DOORS IN GOOD WORKING CONDITION, PROPERLY COUNTERBALANCED AND PROPERLY ADJUSTED IN ACCORDANCE WITH THE DOOR MANUFACTURER'S INSTALLATION INSTRUCTIONS.

Before starting the installation of the operator, the door must be in good working condition and properly counterbalanced. Inspect the door and track for loose or missing hardware. Test the door manually for balance and ease of operation. Lubricate door hinges and rollers. If necessary, adjust the springs for proper counterbalance of the door.

Before removing the operator powerhead from the shipping carton, inspect the nameplate on the cover of the operator control box to verify that it is the correct model for the intended application and that the voltage and phase are in accordance with electrical power provided at the job site.

The rails and drawbar chain/hardware package are shipped separately from the powerhead. **Warning: Rope off the area to keep personnel and vehicles clear of the door and floor space in the vicinity of the operator during the installation.**



WARNING

SPRINGS ARE SUBJECT TO VERY HIGH FORCES AT ALL TIMES AND ADJUSTMENTS MUST BE MADE ONLY BY A QUALIFIED PROFESSIONAL DOOR INSTALLER.



WARNING

REMOVE OR DISABLE ANY LOCKING DEVICES FROM DOOR AND REMOVE ALL ROPES

★ COMPONENT IDENTIFICATION PICTORIAL

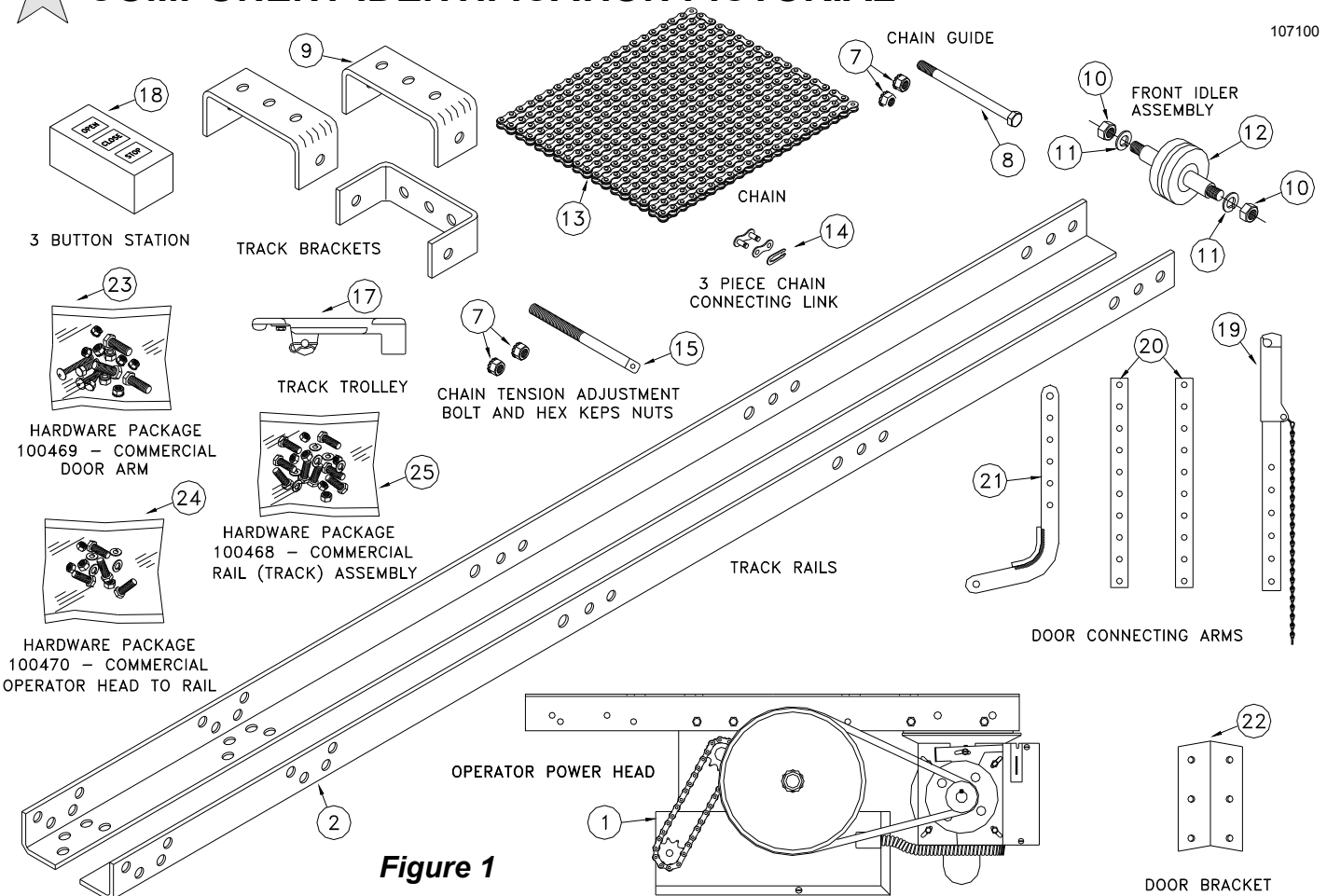

107100

Figure 1



WARNING

TO REDUCE THE RISK OF SEVERE INJURY OR DEATH: READ AND FOLLOW ALL INSTALLATION INSTRUCTIONS!

- Install only on a properly balanced garage door. An improperly balanced door could cause severe injury. Have a qualified service person make repairs to cables, spring assemblies and other hardware before installing the opener.
- Remove all ropes and remove or make inoperative all locks (unless mechanically and/or electrically interlocked to the power unit) that are connected to the garage door before installing the opener.
- Lightweight doors (fiberglass, aluminum etc.) must be reinforced to avoid door damage. Check the door manufacturer’s instruction manual for a bracing procedure or the availability or a Reinforcement Kit. See Page 9.
- Model AUD-S is a Commercial Vehicular Door Operator and as such IS NOT recommended for pedestrian traffic. In installations where it is known that pedestrians will be nearby ensure a pedestrian door is available for entrance and exit to the building. In addition YOU MUST install an auxiliary entrapment protection device (reversing door edge or photoelectric beam device).
- Connect an auxiliary entrapment protection device (reversing edge or photoelectric device across the door opening). a device of this type is

STRONGLY ADVISED FOR ALL commercial operator installations. An auxiliary entrapment protection device is *REQUIRED* when the three button control station is out of sight of the door or any other automatic or manual control is used.

- Install the opener at least 8 feet or more above the floor.
- Do not connect the opener to the source of power until instructed to do so.
- Locate the control station:
 - a) within sight of the door and;
 - b) at a minimum height of five feet above the floor and;
 - c) away from all moving parts of the door.
- Do not overtighten the clutch adjustment to compensate for a poorly working door.
- Securely attach any WARNING signs or placards to either the door or above the control station as directed.
- After installing the opener, all safety features must be tested for proper operation (see page 19).

COMPONENT IDENTIFICATION LISTING



ITEM #	PART#	DESCRIPTION	QUAN.	ITEM #	PART#	DESCRIPTION	QUAN
1		Operator Power Head	1	18	005031	3 Button Station	1
2		Track Rails	2	19	100513	Release Door Arm	1
7	006031	3/8-16 Keps Hex Nut	6	20	100236	Extension Door Arm	2
8	101315	3/8 - 16 X 6-1/2 Hex Head Blot	1	21	100235	Curved Door Arm	1
9	107049	Track Bracket	AR	22	100108	Door Bracket	1
10	006034	1/2 - 15 Hex Nut	2	23	100469	Hardware Pkg Com. Door Arm	1
11	006049	1/2 Split Lockwasher	2	26		3/8 - 16 X 2-1/2 Carriage Bolt	2
12	106265	Front Idler Assembly	1	16		3/8 - 16 X 1 Hex Head Bolt	1
13		Chain For Track Rail	1	27		3/8 Nylon Insert Locknut	1
14		3 Piece Chain Connecting Link	1	28		5/16 - 18 X 1-1/4 Hex Head Bolt	4
15	006084	Chain Tension Adjustment Bolt	1	29		5/16 - 18 Keps Hex Nuts	4
16	006031	3/8 - 16 Keps Hex Nut	2	25	100468	Hardware Pkg Com. Track Assy	1
17	100512	Track Trolley	1	4		3/8 - 16 Hex Nut	AR
				5		3/8 Split Lockwasher	AR
				6		3/8 - 16 X 1-1/2 Hex Head Bolt	AR

— AR - As Required



RAIL/CHAIN ASSEMBLY

Refer to Figure 1 parts illustrations. The part names and item numbers are referenced identically to the part names and numbers in the assembly procedures that follow. Before starting assembly of the operator track check for the proper length. The tracks are supplied for 8 Foot, 10/12/14 Foot, 16/18 Foot and 20/22 Foot high doors. The tracks should be three (3) feet longer than the door height. If the tracks supplied with the operator are longer than the door height plus 3 feet, it will be necessary to cut off two feet (or 4 feet for 10 Foot rail) from the power head mounting end as shown in Figure 2.

CAUTION: WHEN NECESSARY TO CUT THE TRACK ENSURE THE ENDS ARE LINED UP AS IN FIGURE 2.

1) Assemble the operator track by assembling the items as shown in Figure 2.

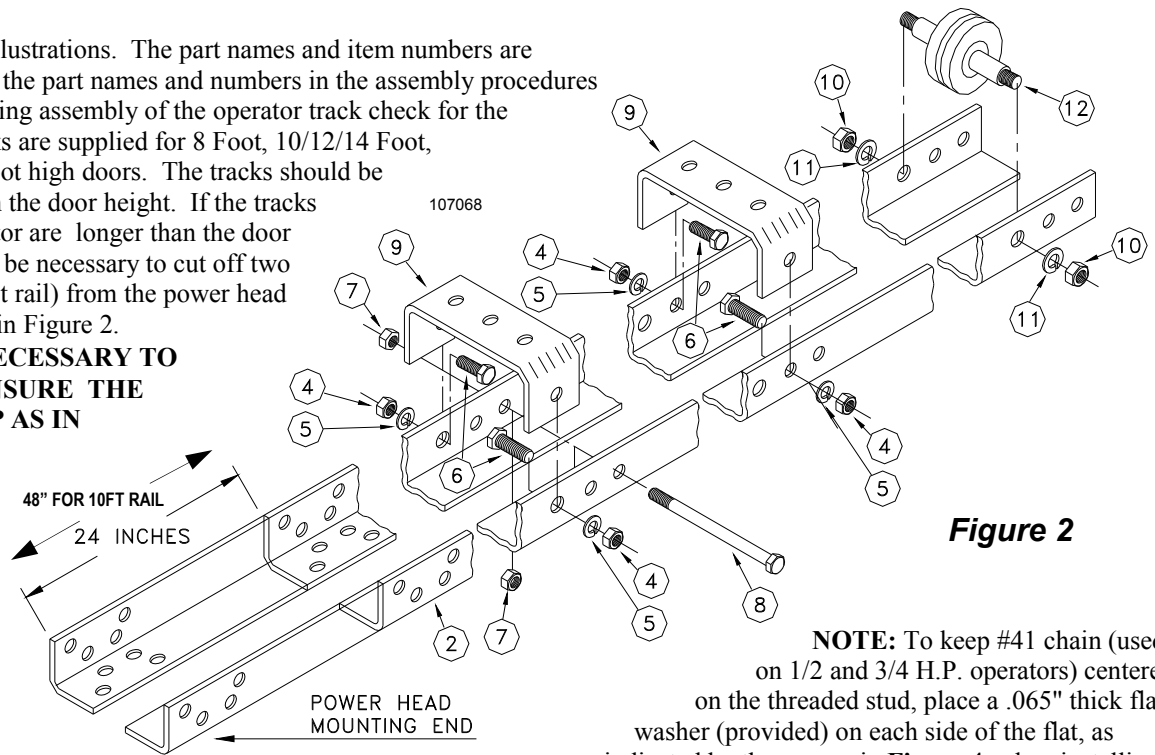

Figure 2

2) After the track is assembled, position track assembly onto the operator power head and attach with four 3/8"-16 x 1" bolts, lock washers and nuts (supplied in a separate hardware package #100470).

3) Referring to Figure 1, 2 and 3 (below), slide the trolley onto the track with the chain take up bolt lug (C) toward the power head. Thread one 3/8-16 keps nut (attached star washer) onto the Chain take up bolt with the keps part (attached star washer) away from the chain attachment end. Insert the chain take up bolt threaded end through the lug hole on the trolley (C) just far enough to start a second 3/8-16 keps nut. Attach one end of the chain to the opposite end of the threaded stud using a 3-piece chain link (provided). See Figure 3.

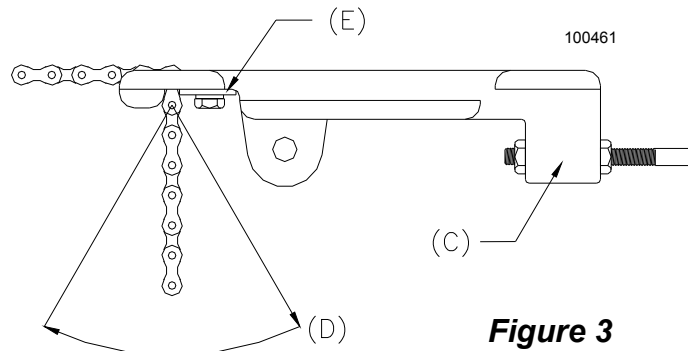

Figure 3

NOTE: To keep #41 chain (used on 1/2 and 3/4 H.P. operators) centered on the threaded stud, place a .065" thick flat washer (provided) on each side of the flat, as indicated by the arrows in **Figure 4**, when installing the connecting link. One-third horsepower operators use the narrower #65 chain and the use of the spacers is not required.

Install chain around drive sprocket at operator head then around idler at front end of rail and thread through opening at front end of carrier. If the rail is equipped with a chain guide-spacer near its center (12 foot rail or longer only) pass the chain over it in one direction and under it in the other direction to separate the two lengths of chain. Apply initial tension by pushing forward on the carrier while pulling chain tight through opening in the carrier in the direction of **D**. When maximum tension has been applied by this means, swing chain forward and insert retaining plate, **E**, in place. Insert 1/4-20 x 5/8 hex head machine screw through retaining plate, **E**, and tighten plate in place. Make final adjustment of chain tension to remove excess sag by adjusting nuts on threaded rod at chain lug, **C**.

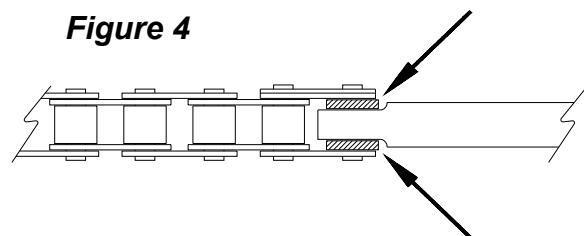

Figure 4



CAUTION

TO AVOID DAMAGE TO DOOR AND OPERATOR ENSURE ALL DOOR LOCKS ARE DISABLED. USE AN INTERLOCK SWITCH IF A LOCK IS REQUIRED TO RETAIN FUNCTIONALITY.



CAUTION

A MINIMUM OF TWO PERSONS ARE REQUIRED FOR OPERATOR INSTALLATION. ENSURE A SAFE RIGID WORKING PLATFORM IS AVAILABLE.

- 1) Locate the center of the door and mark a line on the wall directly above the door. Extend this line approximately 20" up the wall. See Figure 5.

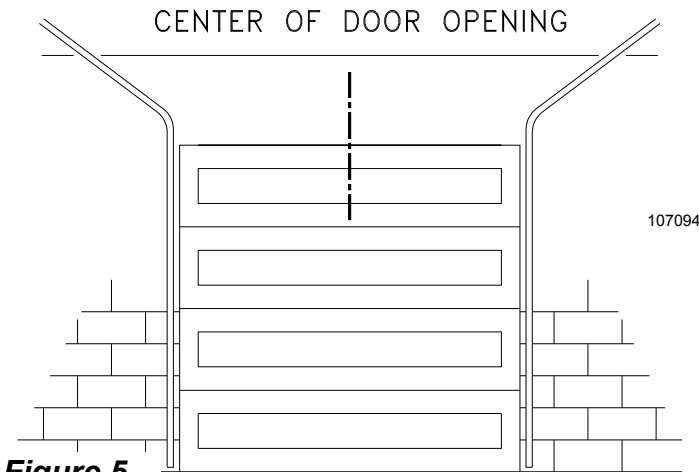

Figure 5

- 2) Slowly raise the garage door and observe the action of the top section. When the top section reaches the highest point (high arc), use a level and project a line from this point to the center of the door. See Figure 6.

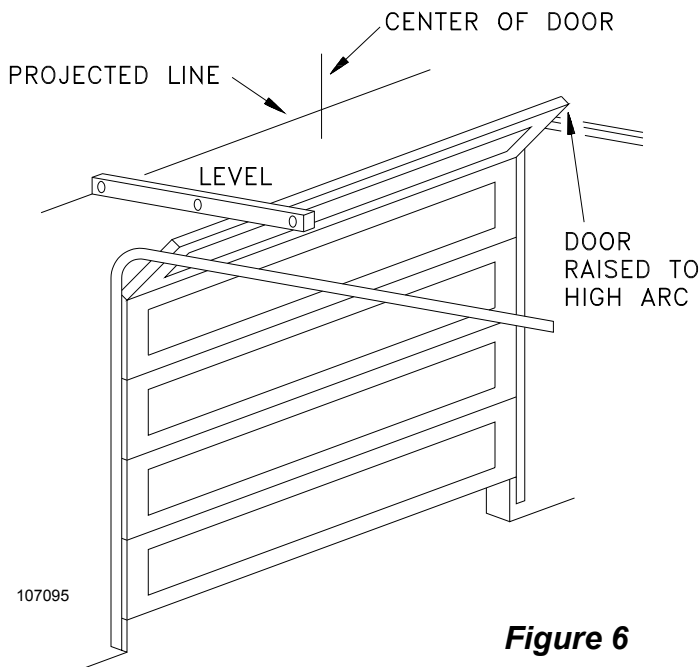

Figure 6

- 3) Using the projected lines for location, mount a suitable wood block or angle iron, depending on the structure of the building, to the wall above the door opening as shown in Figure 7. Ensure the block or angle iron used will provide a sound and secure mounting pad for the operator rail front mounting bracket, see **CAUTION** warning below.

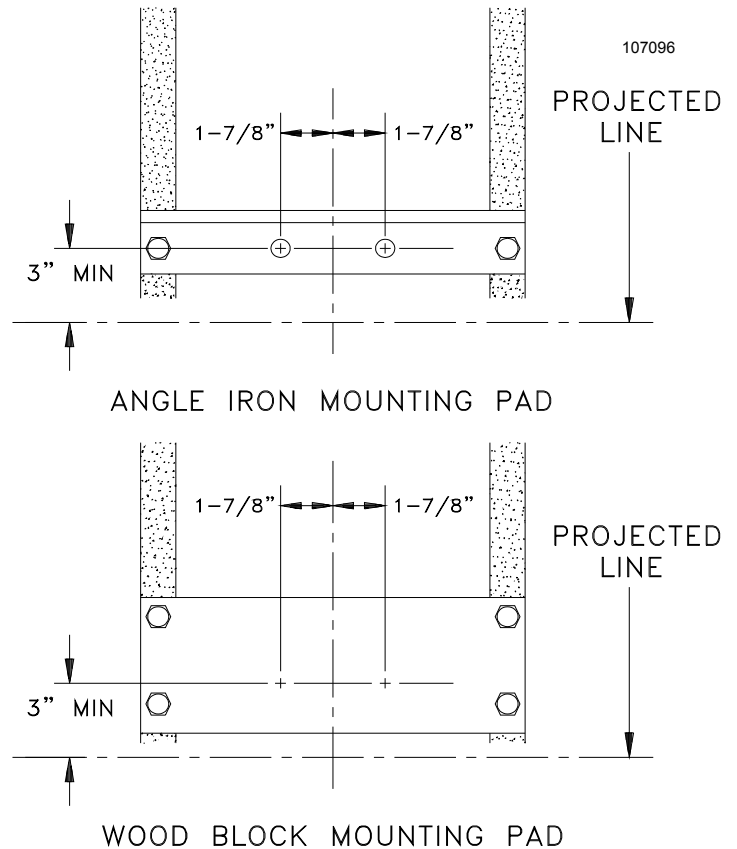

Figure 7



CAUTION

THE FRONT MOUNTING SURFACE FOR THE OPERATOR MUST BE SOUND AND SECURE. IF NECESSARY PROVIDE REINFORCEMENT IN THIS AREA BEFORE MOUNTING THE OPERATOR RAIL FRONT MOUNTING BRACKET.



4) Mount the front mounting bracket (Item 9) to the mounting pad as shown in Figure 8. The location of the door's torsion shaft may prevent you from placing the mounting pad in the location shown. Mount the pad as close as possible to three (3) inches above the door's high arc point.

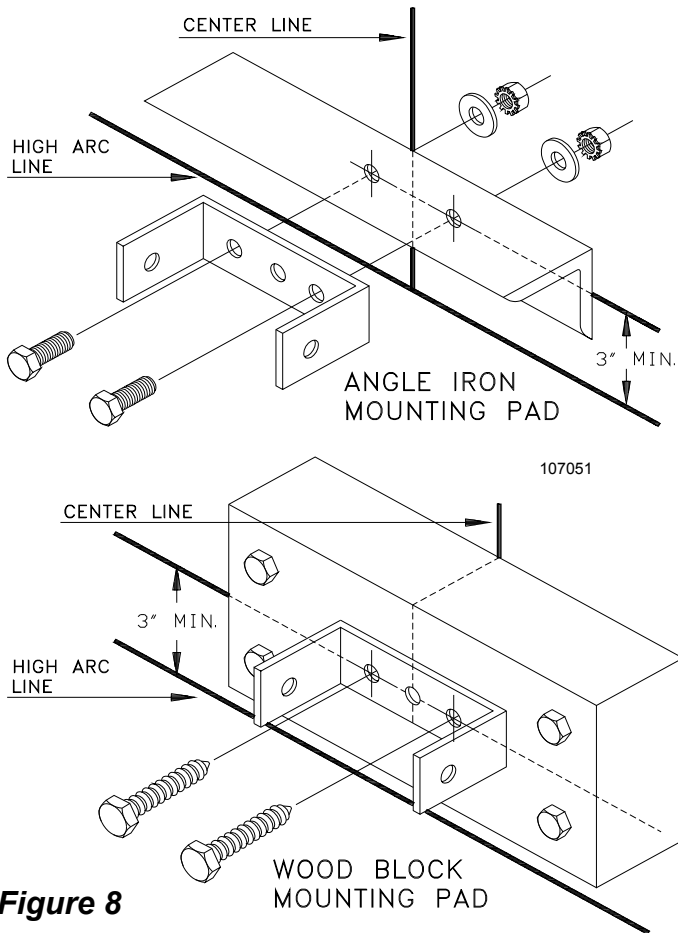

Figure 8

5) With the door in the down position, loosely attach the rail support to the mounting bracket using two (2) bolts, lockwashers and nuts (Items 4, 5, 6). See Figure 9.

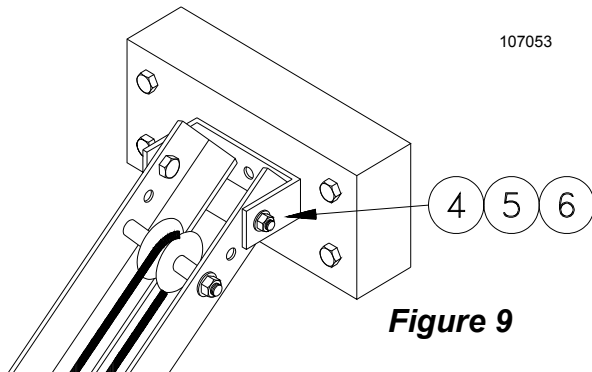

Figure 9

6) Swing the operator to a horizontal position above the door guide rails (high enough to raise the door) and temporarily secure by suspending from the ceiling with a suitable rope or chain or support from the floor to the operator. Now open the garage door slowly, being careful not to dislodge the temporary support. Lower the operator until it is level. Make sure the operator is aligned with the center of the door and the bottom of the rail is at least 2" above the high arc of the door. See Figure 10.

WARNING

FAILURE TO SUSPEND THE OPERATOR SECURELY MAY RESULT IN SERIOUS PERSONAL INJURY OR DEATH.

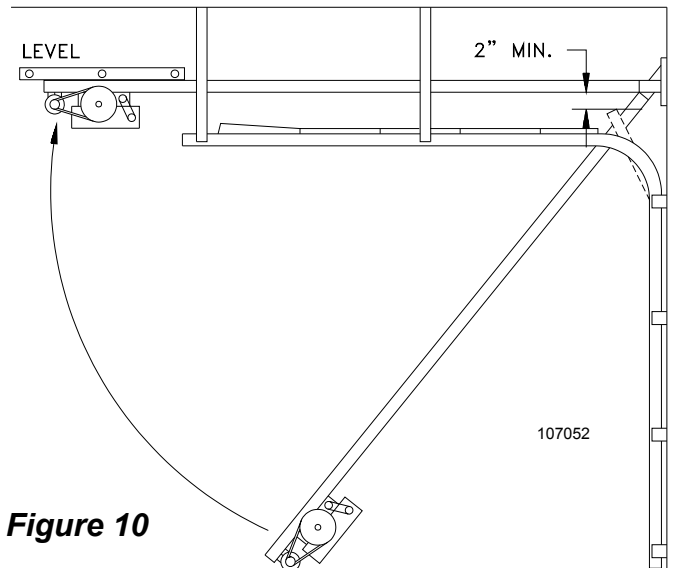

Figure 10

7) Tighten securely the two (2) bolts, nuts and washers that were loosely attached in Step 5. See Figure 11.

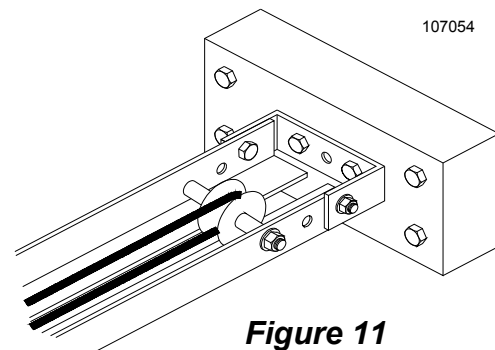

Figure 11

WARNING

SPRINGS, PULLEYS, CABLES AND MOUNTING HARDWARE USED TO BALANCE YOUR GARAGE DOOR ARE UNDER EXTREME TENSION AT ALL TIMES AND CAN CAUSE SEVERE INJURY OR DEATH IF DISTURBED. DO NOT ATTEMPT ADJUSTMENT.



8) Figure 12 details a typical method of hanging the operator from the ceiling. Each installation will vary due to the difference in building structures; but in all installations side braces should be used to further strengthen the installation. If the operator track (rail) is longer than 15 feet a mid support is recommended.

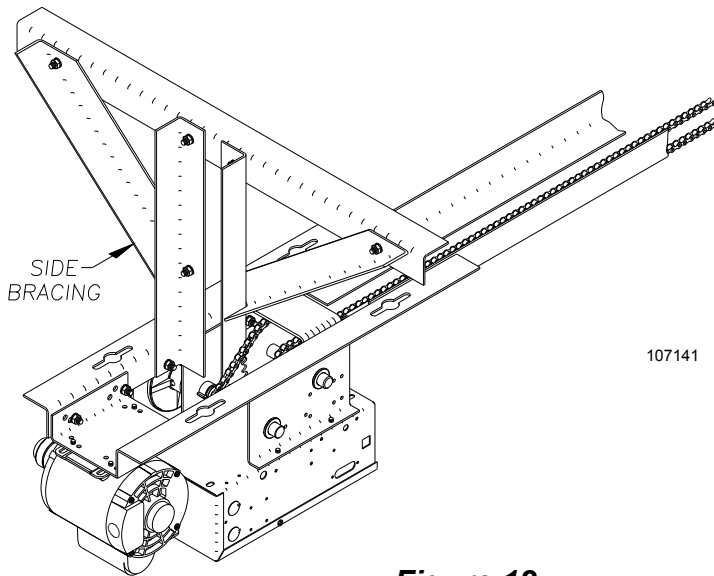

Figure 12

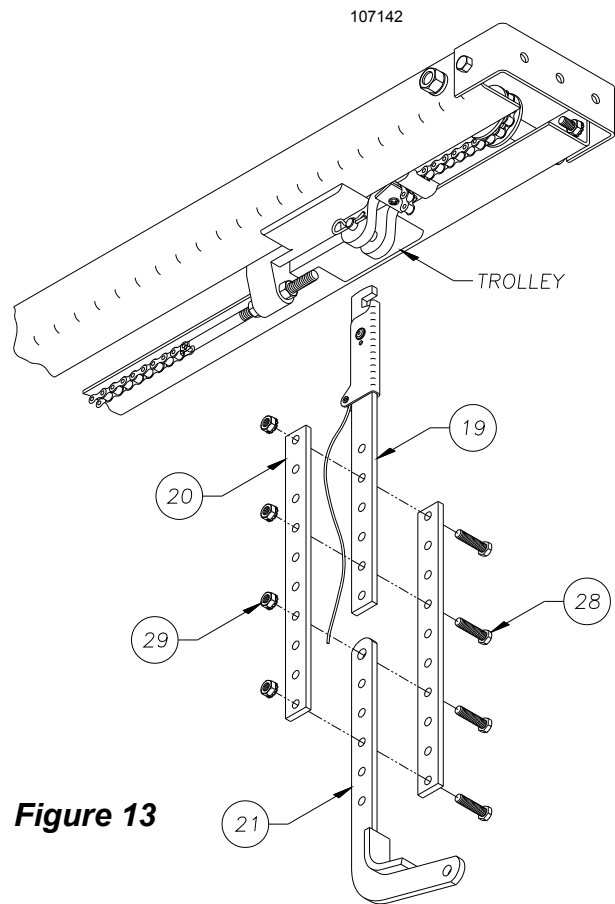

Figure 13

9) Fully close the door and move the trolley to within 2 inches of the idler sprocket. Using Figure 13 as a guide, connect the release arm (Item 19) to the trolley. Connect the two extension arms (Item 20) and the door curved arm (Item 21) to the door release arm with 5/16 inch bolts and keps nuts (Items 28 & 29).

10) Refer to Figure 14. Attach the door bracket (Item 22) to the curved arm using a 3/8 bolt and locknut (Items 16 & 27). Tighten the bolt until snug then back off 1/4 to 1/2 turns so as to allow the arm to pivot on the bolt freely. Position the door bracket to the scribed center line on the door. Use suitable hardware to attach the door bracket to the door.

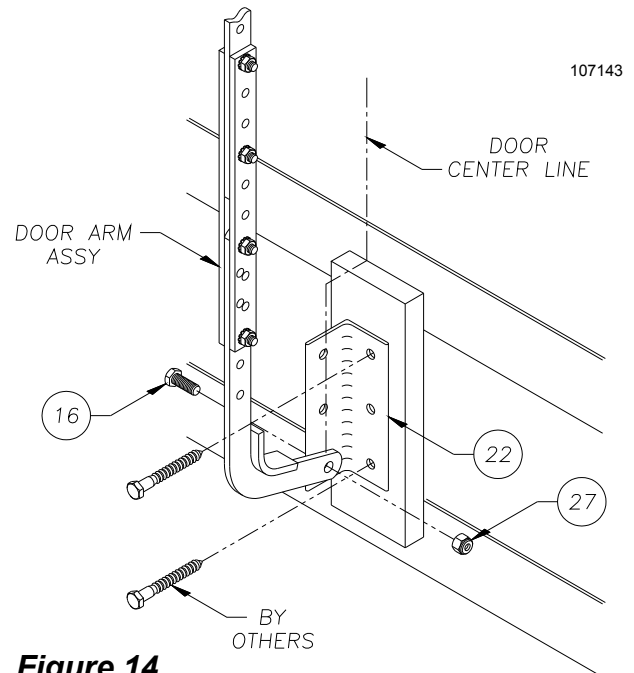

Figure 14

IMPORTANT

TO AVOID DAMAGE TO THE DOOR TOP SECTION REINFORCE THE CENTER STILE WITH A VERTICAL BRACE. ADDITIONAL BRACING/REINFORCEMENT MAY BE REQUIRED WHEN THE DOOR IS CONTROLLED BY AN AUTOMATIC DOOR OPERATOR; CONSULT THE DOOR MANUFACTURER FOR INSTRUCTIONS.

NOTE

BEFORE PROCEEDING RECHECK ALL BOLTS, NUTS AND LAG SCREWS AND ENSURE THEY ARE TIGHT.



WARNING

TO PREVENT THE RISK OF PERSONAL INJURY OR DEATH :

- **DISCONNECT POWER AT THE FUSE BOX BEFORE PROCEEDING.**
- **ELECTRICAL CONNECTIONS MUST BE MADE BY A QUALIFIED INDIVIDUAL.**
- **OBSERVE LOCAL ELECTRICAL CODES WHEN WIRING THE OPERATOR.**

WARNING: The AUD-S Series operators have been designed and constructed for use with voltages from 115 Volts AC to 480 Volts AC, in single or three phase. Check the operator nameplate label on the control box cover for the proper voltage and phase. The application of an improper input voltage or phase will result in catastrophic failure to the internal electrical components.

Observe local electrical codes when wiring the operator.

When hard wiring, observe state and local electrical codes. A wiring diagram is attached to the inside of the control box cover. Connect the appropriate voltage and phase power leads to the appropriate terminals as per the wiring diagram and connect a ground wire to the grounding screw. On three phase units, incorrect phasing of the power supply will cause the motor to rotate in the wrong direction (open when CLOSE button is pushed and vice versa). To correct this, interchange any two of the incoming three phase conductors.

The wiring diagram attached inside the cover of the control box details all of the field wiring terminal connections for the operator. Always connect the wires to the push-button controls and auxiliary devices exactly as shown.

Warning: Control voltage of the opener is 5 volts DC, Class 2. Do not run the power leads and control circuit wiring in the same electrical conduit.



WARNING

TO PREVENT THE RISK OF PERSONAL INJURY AND/OR DAMAGE TO DOOR OR PROPERTY, ONLY OPERATE DOOR CONTROL WHEN DOOR IS IN CLEAR VIEW. IF CONTROL STATION CANNOT BE LOCATED WHERE THE DOOR IS VISIBLE OR IF ANY OTHER DEVICE IS USED TO CONTROL THE DOOR AN AUXILIARY ENTRAPMENT DEVISE (DOOR EDGE OR PHOTOELECTRIC) *MUST BE CONNECTED.*



WARNING

RISK OF ENTRAPMENT THAT MAY RESULT IN SERIOUS PERSONAL INJURY OR DEATH. DISCONNECT POWER TO THE OPENER BEFORE AND DURING INSTALLATION OF AN ACCESSORY REVERSING DOOR EDGE OR PHOTOELECTRIC DEVICE. DO NOT RECONNECT POWER TO OPENER UNTIL INSTRUCTED TO DO SO. ENSURE DOORWAY IS CLEAR BEFORE STARTING TESTING OF UNIT.

Note: AUD-S Series model openers are pre-wired for door reversing edge components. To comply with code requirements, the door reversing edge components must be installed and wired to the opener. Refer to Figure 15 Door Edge component installation and Figure 16 for Door Edge and photoelectric device wiring.

If a Safe-Finish™ or Access Alliance Safe-Finish II™ photo-beam is connected and the photo-beam detects an obstruction or becomes inactive, an opening door continues to open and a closing door stops, pauses and starts open. While in this mode, if a problem is detected while the opener is stopped, a close action will require constant activation of the push button. If the photo-beam is attached and is properly working for 1 second, it will be *auto detected and the monitored function will be turned on*. Once the monitoring function is active, it will remain active even if the power is removed and the photo-beam is disconnected and power is restored. While in this mode, if a problem is detected while the opener is stopped, a close will require constant activation.

Openers which are equipped with a reversing edge circuit may have one or more additional means of control which should be wired in accordance with the diagram supplied in the opener and also illustrated on Pages 20 & 21. To add a second three button station, refer to Figure 18.

Number 22 gauge wire or heavier must be used for wiring the control stations and auxiliary control devices to the operator. Smaller gauge wire will cause operational problems, especially when multiple push-button stations are used or during summer months.



CAUTION

TO AVOID DAMAGE TO DOOR AND OPERATOR ENSURE ALL DOOR LOCKS ARE DISABLED. USE AN INTERLOCK SWITCH IF A LOCK IS REQUIRED TO RETAIN FUNCTIONALITY.



PNEUMATIC DOOR EDGE INSTALLATION - FIELD WIRING - 11

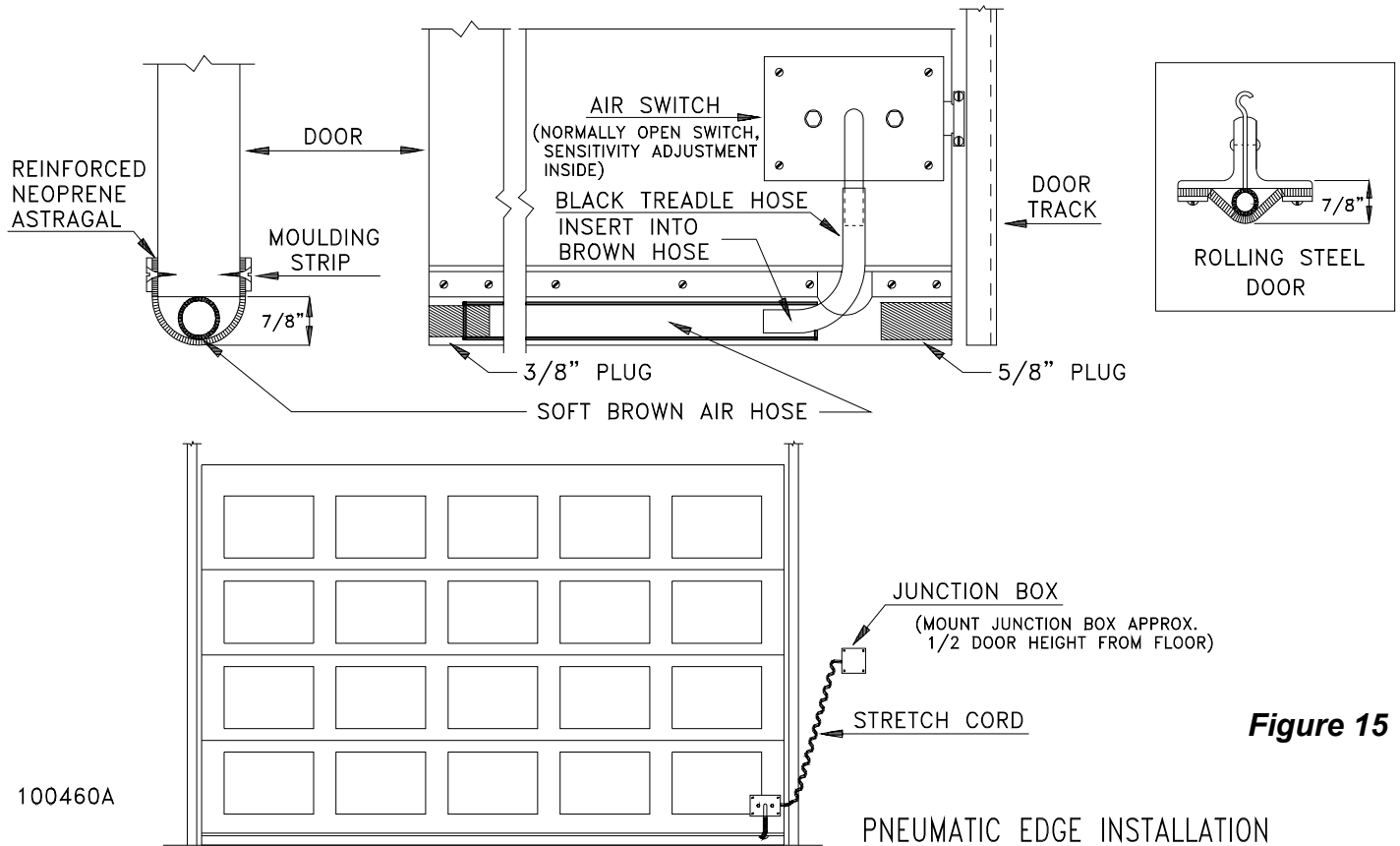

Figure 15

100460A

MOTOR CONTROL BOARD

Figure 16

Door Edge and Photoelectric Wiring

See text on page 10 for operation when Safe-Finish™ or Access Alliance Safe-Finish II™ photo-beams are connected.

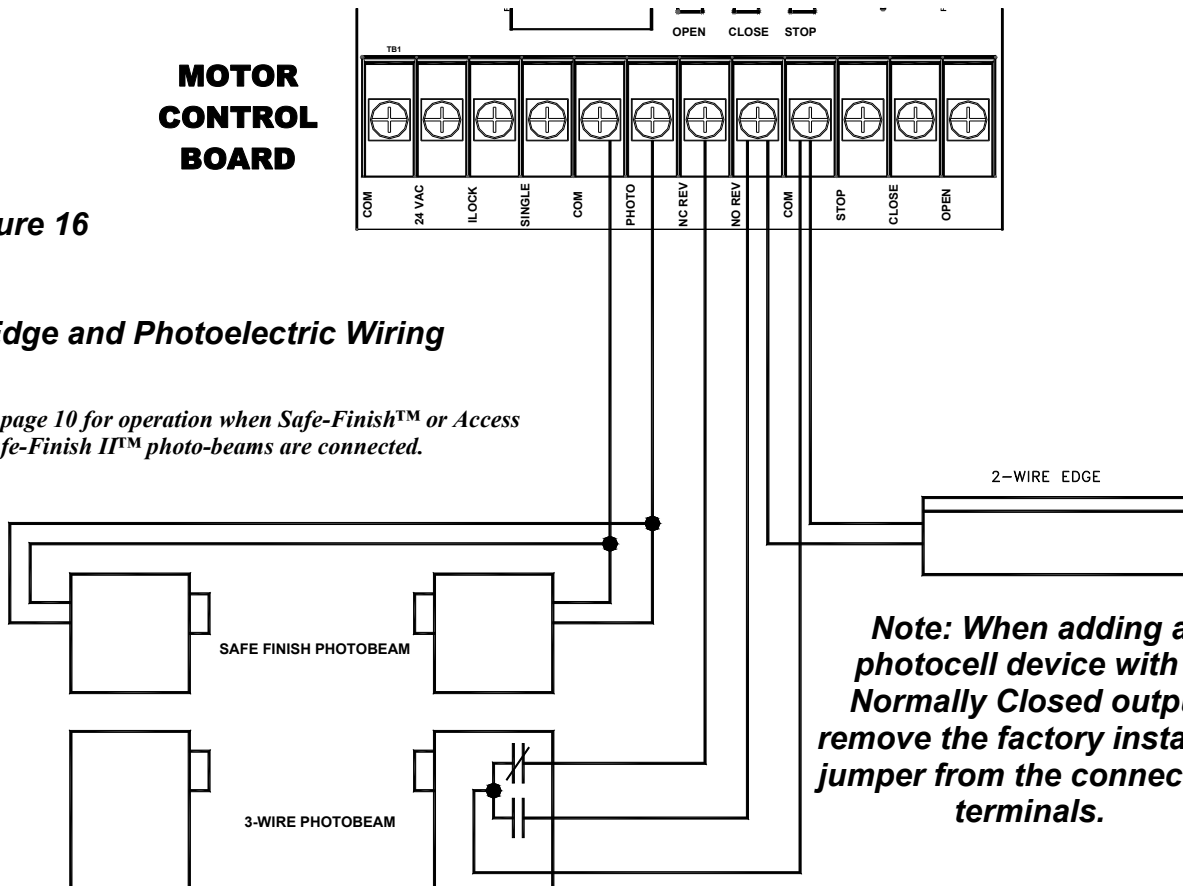

Note: When adding a photocell device with a Normally Closed output remove the factory installed jumper from the connection terminals.

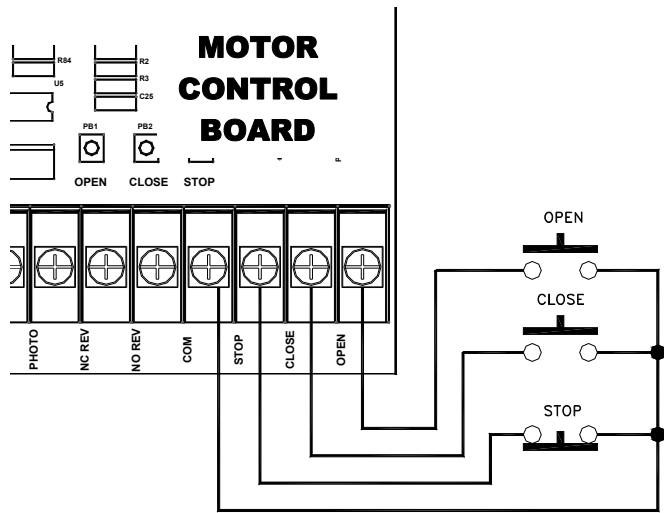

Single 3 Button Station **Figure 17**

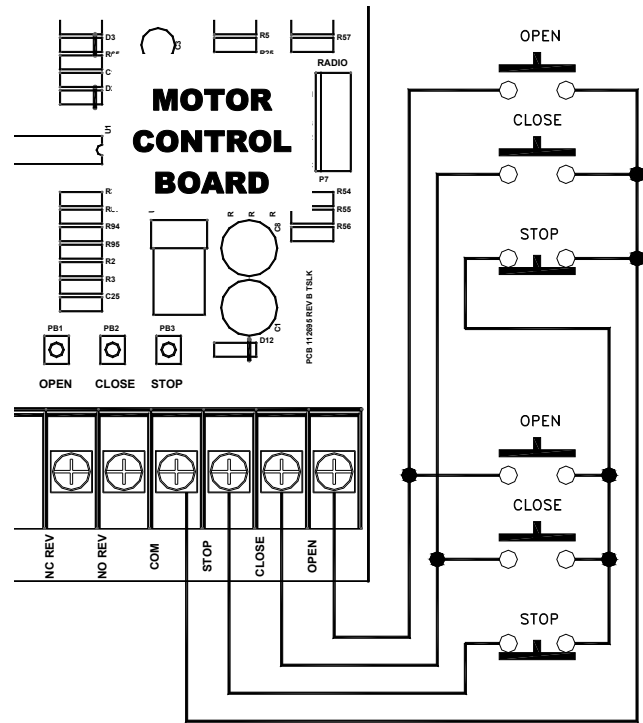

Multiple 3 Button Station **Figure 18**

MOTOR CONTROL BOARD

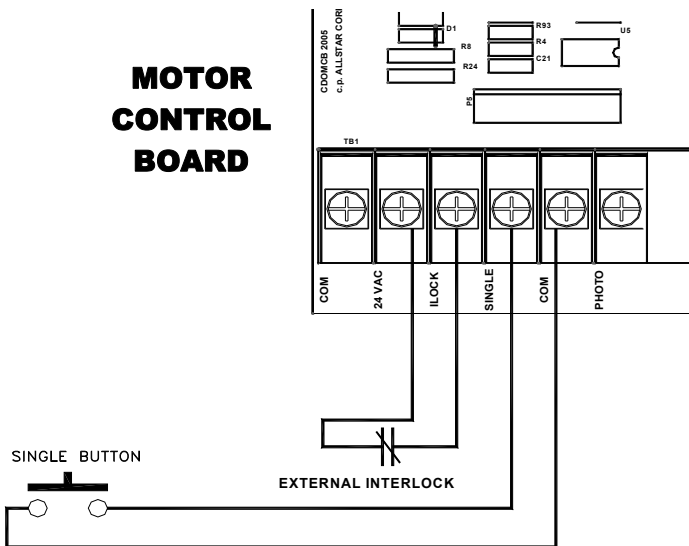

Figure 19

Single Button and External Interlock Wiring

Note: When adding an External Interlock remove the factory installed jumper from the connection terminals.

TURNING ON THE POWER TO THE OPERATOR

NOTE: It is now necessary to turn on the power in order to change the Operating Mode (if applicable), program any changes desired to the operator's other settings, check for proper performance of all the operator's features to include the brake (if applicable) and clutch (adjusting settings if necessary); and to set and finalize any adjustments to the limit settings. Before doing so, ensure that all mounting hardware are installed and properly tightened, that all electrical connections are per local code requirements, and that proper wiring practices have been followed. Also, double-check that all ropes have been removed from the door and that the doorway is clear.



IMPORTANT SAFETY INSTRUCTIONS FOR OWNER



WARNING

TO REDUCE THE RISK OF SEVERE INJURY OR DEATH: READ AND FOLLOW ALL INSTRUCTIONS!

- Understand all of the operating features of your door control system at the time of its installation. Your installing dealer will demonstrate them for you.
- NEVER let children operate or play with door controls. Keep the Remote Control away from children.
- ALWAYS keep a moving door in sight and keep people and objects away from the door area until the door is completely closed. NO ONE SHOULD CROSS THE PATH OF A MOVING DOOR.
- TEST THE DOOR OPENER'S REVERSING FEATURE (where applicable) MONTHLY. The door MUST reverse upon contact with a 4" high object on the floor. After adjusting the force setting (clutch) or the limit of travel, ALWAYS RETEST the Opener. Failure to ADJUST THE OPENER PROPERLY may result in SERIOUS INJURY OR DEATH.
- If possible, USE THE MANUAL RELEASE only when the door is closed. Use caution when using the Release with the door open. WEAK OR BROKEN SPRINGS MAY ALLOW THE DOOR TO CLOSE RAPIDLY, CAUSING SEVERE INJURY OR DEATH.
- KEEP THE GARAGE DOOR PROPERLY BALANCED. See the door owner's manual. An improperly balanced door MAY CAUSE SEVERE INJURY OR DEATH. Have a QUALIFIED SERVICE PERSON MAKE REPAIRS TO CABLES, SPRING ASSEMBLIES AND OTHER HARDWARE. SAVE THIS INSTRUCTION MANUAL FOR END USER
- Inspect and maintain your door system as described in this manual.



WARNING

**AVOID ELECTROCUTION:
DO NOT ROUTE LOW VOLTAGE WIRES IN
SAME CONDUIT AS HIGH VOLTAGE
WIRES. FOLLOW ALL LOCAL
ELECTRICAL CODES OR THE NATIONAL
ELECTRICAL CODE.**



WARNING

**FAILURE TO TEST REVERSING
SYSTEM COULD RESULT IN DEATH
OR SERIOUS INJURY. TEST THIS
SYSTEM ONCE A MONTH.**



SETTING THE SWITCH SELECTABLE OPERATING MODES

Changing the Switch Selectable Operation Modes

The following modes are selected by setting the on-board dip switches, Figure 20 at right shows where the switches are located on the operator control board. For each Operational Mode, the switches are set to either ON or OFF according to the table at right below. For all the modes, if a reversing device is attached, it will function as noted. If a monitored reversing device has been recognized and becomes inactive then the mode will default to constant pressure activation for close regardless of the dip switch setting. The switches must be set to **one** of the six Operational Mode combinations for the operator to function.

C2 Operation (Factory default)

Open Button: Momentary activation; open override of closing door.

Close Button: Constant activation, door will stop when butto full open (ignores mid-stop) unless stopped by stop pushbutton input.

Mid-Stop: Activation stops an opening door; momentary contact of open button at mid stop will restart door to full open position; if door is moving open, constant pressure on open button will bypass mid-stop.

Stop Button: Momentary activation; stops open, close or reverse action.

Single Button: Momentary activation to open; open override of closing door.

Reverse: Momentary activation will reverse a closing door, reverse to

Auto Close Timer: N/A.

B2 Operation

Open Button: Momentary activation; open override of closing door.

Close Button: Momentary activation.

Stop Button: Momentary activation; stops open, close or reverse action.

Single Button: Momentary activation to open; open override of closing door, closes door from mid-stop or open limit.

Reverse: Momentary activation will reverse a closing door, reverse to full open (ignores mid-stop) unless stopped by stop pushbutton input.

Mid-Stop: Activation stops an opening door; momentary contact of open button at mid stop will restart door to full open position; if door is moving open, constant pressure on open button will bypass mid-stop.

Auto Close Timer: N/A.

D1 Operation

Open Button: Constant activation; open override of closing door.

Close Button: Constant activation, door will stop when button is released.

Stop Button: Momentary activation; stops open, close or reverse action (not required).

Single Button: N/A.

Reverse: Momentary activation will stop a closing door.

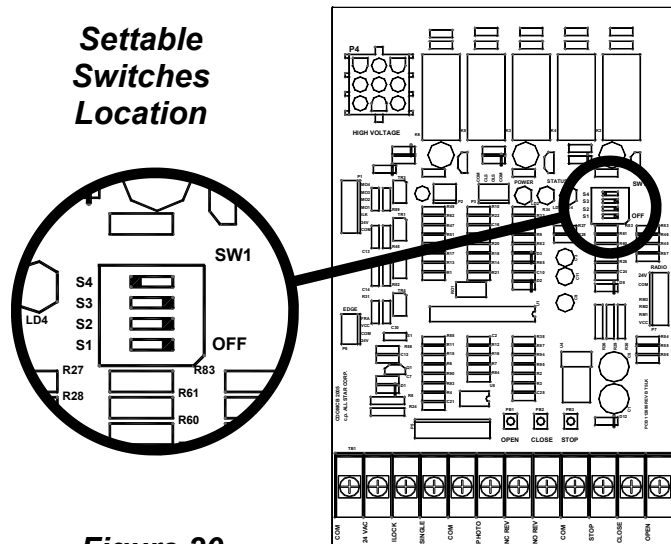

Figure 20

MOTOR CONTROL BOARD

Operating Mode	Switch 1	Switch 2	Switch 3	Switch 4
C2 Operation	OFF	OFF	OFF	OFF
B2 Operation	ON	OFF	OFF	OFF
D1 Operation	OFF	ON	OFF	OFF
E2 Operation	ON	ON	OFF	OFF
TS Operation	OFF	OFF	ON	OFF
T Operation	ON	OFF	ON	OFF

Mid-Stop: Activation stops an opening door; after the door stops at the mid stop, constant contact of open button at mid stop will restart door to full open position.

Auto Close Timer: N/A.

E2 Operation (roll-back)

Open Button: Momentary activation; open override of closing door.

Close Button: Constant activation, door will reverse to full open (ignores mid-stop) when button is released.

Stop Button: Momentary activation; stops open, close or reverse action.

Single Button: N/A.

Reverse: Momentary activation to reverse a closing door, reverse to full open (ignores mid-stop) unless stopped by stop pushbutton input.

Mid-Stop: Activation stops an opening door; momentary contact of open button at mid stop will restart door to full open position; if door is moving open, constant pressure on open button will bypass mid-stop.

Auto Close Timer: N/A



TS Operation

Open Button: Momentary activation; open override of closing door.

Close Button: Momentary activation.

Stop Button: Momentary activation; stops open, close or reverse action.

Single Button: Momentary activation to open; open override of closing door, closes door from mid-stop or open limit.

Reverse: Momentary activation will reverse a closing door, reverse to full open (ignores mid-stop) unless stopped by stop pushbutton input.

Mid-Stop: Activation stops an opening door; momentary contact of open button at mid stop will restart door to full open position; if door is moving open, constant pressure on open button will bypass mid-stop.

Auto Close Timer: Closes door from mid-stop or open limit after pre-set time. Stop will deactivate the auto close timer. Open will reactivate the auto close timer or reset the auto close timer when the door is at the mid-stop or open limit. Single button will reset the auto close timer from the mid-stop or open limit. Reverse will reactivate the auto close timer or reset the auto close timer when the door is at the mid-stop or open limit.

T Operation, Dip-Switch Setting

Open Button: Momentary activation; open override of closing door.

Close Button: Momentary activation.

Stop Button: Momentary activation; stops open, close or reverse action.

Single Button: Momentary activation to open; open override of closing door, closes door from mid-stop or open limit.

Reverse: Momentary activation will reverse a closing door, reverse to full open (ignores mid-stop) unless stopped by stop pushbutton input.

Mid-Stop: Activation stops an opening door; momentary contact of open button at mid stop will restart door to full open position; if door is moving open, constant pressure on open button will bypass mid-stop.

Auto Close Timer: Closes door from mid-stop or open limit after pre-set time. Stop will deactivate the auto close timer. Open will reactivate the auto close timer or reset the auto close timer when the door is at the open limit. Single button will reset the auto close timer from the mid-stop or open limit. Reverse deactivates the auto close timer if the door is closing. Reverse will reset the auto close timer at the mid-stop or open limit if the auto close timer has not been previously deactivated.

SETUP MODES

Setup Modes

Various operating characteristics can be modified via the setup modes. The operator is moved to the close limit position and the on-board dip switches (see Figure 20, page 14) are **TEMPORARILY** set according to the table at right to enter a Setup Mode. The on board OPEN and STOP buttons are used to modify the characteristic. Once set, the values are stored in non-volatile memory.

These values are set to factory defaults that should be satisfactory for many applications. All values as described here can be reset to the factory defaults as follows:

Remove 24 VAC power from the control board.

Press and hold the on-board stop button.

Re-apply 24 VAC while holding the on-board stop button.

After completing the procedure to modify the operating characteristic the switches must be returned to the originally set Operating Mode setting (see section previous).

Delay on Reverse Setup

To help prevent stress on the door components, this feature allows for a delay time between the door stopping and reversing when a command to reverse is received as the door is closing. The factory default time is 0.75 seconds; the minimum time is 0.4 seconds; the maximum time is 2 seconds.

After moving the door to the close position and **temporarily** setting the switches to the appropriate settings in the table, pressing STOP will reset the time to the minimum setting. Every time OPEN is pressed, 200 mS is added to the time (up to the maximum).

Changing the dip-switch setting to any other setting will save the new time. Return the dip switches to the originally set

Setup Mode	Switch 1	Switch 2	Switch 3	Switch 4
Delay on Reverse	ON	ON	ON	ON
Close Limit Delay	OFF	ON	ON	ON
Mid-Stop Limit	ON	OFF	ON	ON
Auto Close Timer	OFF	OFF	ON	ON
Maximum Run Time	OFF	ON	OFF	ON

Operating Mode setting (see section previous).

Close Limit Delay Setup

To provide for irregularities in the floor, this feature allows for the door to continue to travel down after the Reverse Cutout Limit is activated. The factory default time is 0.32 seconds; the minimum time is 0.12 seconds; the maximum time is 0.66 seconds.

After moving the door to the close position and **temporarily** setting the switches to the appropriate settings in the table, pressing STOP will reset the time to the minimum setting. Every time OPEN is pressed, 0.02 seconds are added to the time (up to the maximum).

Changing the dip-switch setting to any other setting will save the new time. Return the dip switches to the originally set Operating Mode setting (see section previous).



Mid-Stop Limit Setup

This feature provides a timing function to stop a door as it is traveling open at a Mid Stop position instead of the full open position. The door can then be moved to the full open position if desired by pressing the Open button. A single button input when the door is at the mid stop position will cause the door to begin moving in the close direction. The factory default is not set; the minimum run time to mid-stop limit is 6 seconds. After moving the door to the close position and *temporarily* setting the switches to the appropriate settings in the table, pressing STOP will remove the mid-stop limit setting. Pressing OPEN will start the door open. When the door reaches the desired mid-stop position, press STOP. Changing the dip-switch setting to any other setting will save the mid-stop limit position. Return the dip switches to the originally set Operating Mode setting (see section previous). *Note: The door must move a sufficient distance to fully disengage the Reverse Cutout Limit nut from the Reverse Cutout Limit switch to set the mid-stop limit.*

Auto Close Timer Setup

This feature allows for a modification of the amount of time between the door reaching either the Mid Stop or the Full Open position and automatically starting in the close direction. The Auto Close feature is only active when the operator is set to the T or TS Operating Mode (see section previous). The factory default is 30 seconds; the minimum time is 5 seconds; the maximum time is 5 minutes.

After moving the door to the close position and *temporarily* setting the switches to the appropriate settings in the table, pressing STOP will clear and turn off the auto close timer. Every time OPEN is pressed, 5 seconds is added to the time. Changing the dip-switch settings to any other settings will save the new time. Return the dip switches to the originally set Operating Mode setting (see section previous).

Maximum Run Time Setup

This feature provides for a maximum amount of time the motor will be energized after an input is recognized. The factory default time is 30 seconds; the maximum time is 60 seconds. After moving the door to the close position and *temporarily* setting the switches to the appropriate settings in the table, pressing STOP will reset the time to the factory default setting. Pressing OPEN will start the door open. The run time will be recorded when the door reaches the open limit. To prevent nuisance problems, 0.75 seconds are added to this time. Pressing stop before the door reaches the open limit will stop the door and reset the time to the factory default. Changing the dip-switch setting to any other setting will save the new time. Return the dip switches to the originally set Operating Mode setting (see section previous).

BRAKE ADJUSTMENT

The solenoid operated brake may require occasional adjustment. Adjustment is necessary if door tends to drift downward after reaching the open limit. Follow the instructions below and use Figure 21 as a guide.

- (1) Loosen shoe adjusting screw and bottom bracket arm of solenoid.
- (2) Move tab until drum has a slight drag.
- (3) Reverse drag slightly from tab and tighten shoe adjustment screw.

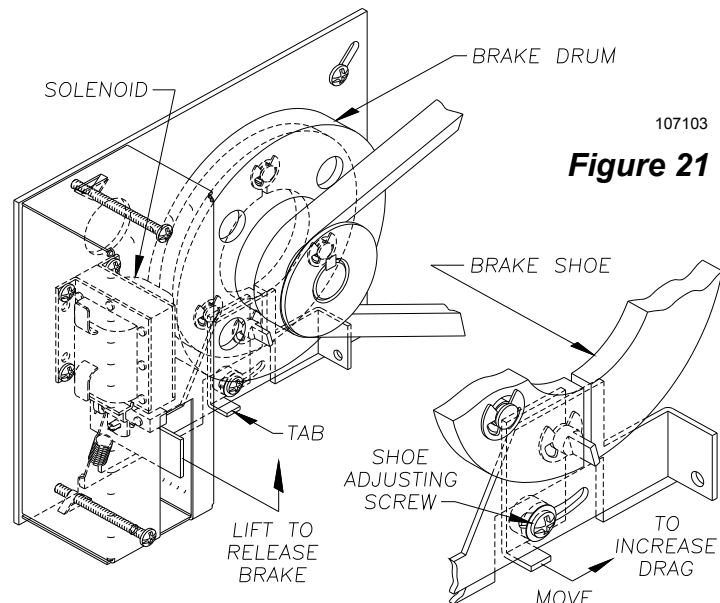

107103
Figure 21



WARNING

TO AVOID RISK OF ENTRAPMENT AND POSSIBLE DAMAGE TO THE DOOR AND OPERATOR THE CLUTCH MUST BE ADJUSTED AND ANY ENTRAPMENT PROTECTION DEVICES CONNECTED BEFORE APPLYING POWER TO THE OPERATOR TO SET THE LIMITS.

SETTING THE LIMIT SWITCHES

1) With the cover open on the electrical enclosure, reference Figure 23 below. There are two (2) switches (A and B) mounted to the 'V' bracket (F). The switches are activated by the two limit nuts (C and E) on the threaded shaft which move laterally along the shaft as the operator opens and closes the door. When a limit nut nears the end of the shaft it activates a switch, that send a message back to the motor control board to stop the door. Follow either 2 or 2A below depending on how the door and trolley are orientated.

2) For original installation setting, the door (connected as normal to the operator trolley) should be positioned approximately 4 inches shy of the fully closed position. If this is the case, depress the Limit Nut Retention Plate (D) so it disengages from the slots in the limit nuts and move the Close Limit Nut (C) on the shaft until it engages the Close limit Limit Switch (B) (see Step 5 for an explanation of the Close limit function). You will need to listen for an audible click. Move the Open Limit Nut (E) to the center of the threaded shaft. Release the retaining bracket and be sure that it engages in slots of both limit nuts.

2A) If the door and operator trolley are at some other position other than fully closed, depress the Limit Nut Retention Plate (D) so it disengages from the slots in the limit nuts and move the **BOTH** the Limit nuts to the center of the threaded shaft. Release the retaining bracket and be sure that it engages in slots of both limit nuts.

3) With all due care use the built-in three button station on the motor control board or the wall mounted three button station to raise the door to the fully open position. You will need to

remember to use the STOP button to stop the door at the Fully Open Position.

4) Depress the limit nut retaining plate (D) so it disengages from the slots in the limit nuts. Turn the OPEN limit nut (E) on the shaft until it engages the Open Limit Switch (A). You will need to listen for an audible click. Release the retaining bracket and be sure that it engages in slots of both limit nuts.

5) With all due care use the built-in three button station on the motor control board or the wall mounted three button station to lower the door to approximately 4 inches shy of the fully closed position and repeat Step #4 with the Close Limit nut (C) and the Close Limit switch (B). The actual Close Limit position is a timed function whereas the door continues to run for a certain period of time after the Close Limit switch is activated. This amount of time (Close Limit Delay) is factory set to 0.32 seconds and will provide reversing cutout of approximately 4 inches from the floor for a door traveling at 12 inches per seconds. If the door fails to reverse when an object at least four inches high is placed in its path (see Testing, page 19) it may be necessary to adjust the Close Limit Delay time, see procedure on page 15.

6) Move the door to the fully open position then the fully closed position and observe the stopping position. Reset the Limit Nut(s) per above instructions if desired.

7) A fine adjustment can be done (if necessary) by loosening the screws holding the Limit Switches to the V bracket and moving the switch within the slots on the bracket.

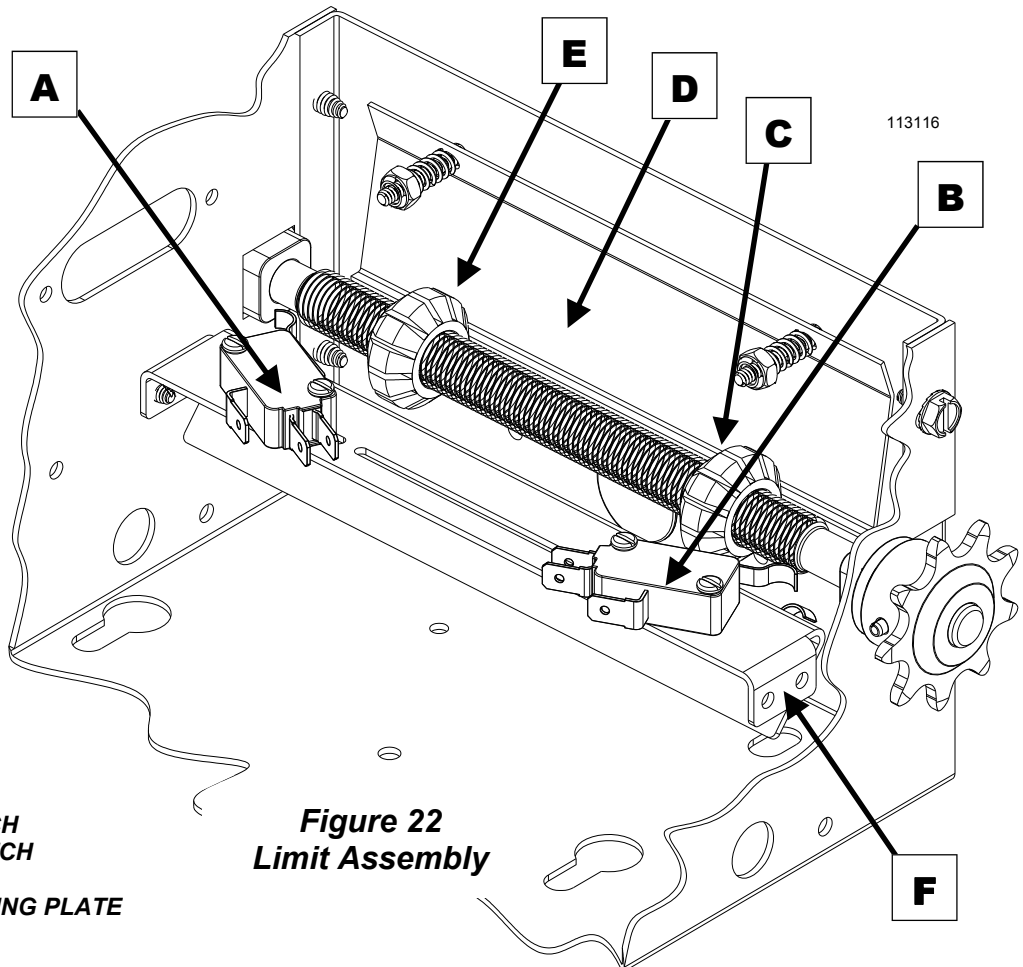

Figure 22
Limit Assembly

- A - OPEN LIMIT SWITCH**
- B - CLOSE LIMIT SWITCH**
- C - CLOSE LIMIT NUT**
- D - LIMIT NUT RETAINING PLATE**
- E - OPEN LIMIT NUT**
- F - "V" BRACKET**



CLUTCH ADJUSTMENT



WARNING

RISK OF ENTRAPMENT THAT MAY RESULT IN SERIOUS PERSONAL INJURY OR DEATH. DISCONNECT POWER TO THE OPENER BEFORE SERVICING OR MAKING ADJUSTMENTS. ENSURE DOORWAY IS CLEAR BEFORE STARTING TESTING OF OPERATOR.

The fiber disk will wear during normal operation and should be replaced when it becomes difficult or impossible to sufficiently tighten the clutch to obtain smooth operation of the door when it is in good working condition. To replace the fiber disk, first loosen the motor mounting bolts and remove the V-belt then the clutch adjusting nuts, spring and clutch pulley. Check condition of V-belt before reassembly and replace if required. After reassembly, adjust clutch as described above.

The clutch serves to protect the door, the electric operator and other equipment from undue stress or damage caused by starting forces and/or an obstruction to the door. It should be set no tighter than is necessary to smoothly and consistently move the door throughout its full range of travel. When properly set, it will slip freely if the door should encounter an obstruction, and it should be possible to stop the travel of the door by hand.

WARNING: Before adjustment remove power to the operator.

To adjust the clutch, loosen the jamb nut, and turn the adjusting nut, as shown at right. Make adjustments in 1/4 turn increments. Always re-tighten the jamb nut before running the operator to prevent clutch from changing its setting.

CAUTION

NEVER COMPRESS CLUTCH SPRING BEYOND POINT LIMITED BY THE DESIGN OF THE OPERATOR OR REPLACE IT WITH A HEAVIER SPRING

Due to changing conditions of the door and normal wear, it may be necessary to occasionally readjust the clutch to obtain dependable operation.

WARNING: BEFORE DOING SO BE CERTAIN THAT THE DOOR IS IN GOOD WORKING CONDITION, PROPERLY COUNTERBALANCED AND THAT THE CLUTCH IS NOT SLIPPING BECAUSE OF LOOSE OR MISSING HARDWARE, BINDING IN THE TRACK, RUBBING AGAINST THE DOOR STOPS OR DEFECTIVE OR MISADJUSTED SPRINGS. ANY SERVICE REQUIRED TO THE DOOR, DOOR SPRINGS OR DOOR OPERATOR MUST BE PREFORMED BY A QUALIFIED PROFESSIONAL DOOR INSTALLER.

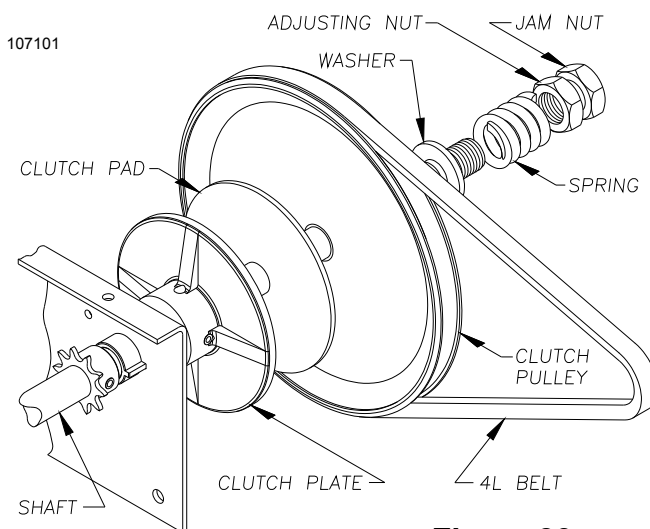

Figure 23



WARNING

IMPROPER ADJUSTMENT OF CLUTCH SETTING COULD CAUSE ENTRAPMENT, INJURY OR DEATH. SET CLUTCH ADJUSTMENT FOR JUST ENOUGH FORCE TO OPERATE THE DOOR RELIABLY, BUT NO STRONGER. Contact a service professional to correct any binding, sticking or other door problems. DO NOT OVER-ADJUST CLUTCH SETTING TO COMPENSATE FOR A POORLY WORKING DOOR.



TESTING

Following installation, the operator **MUST** be tested and respond correctly to all controls as specified on the wiring diagram. Keep personnel and equipment clear of the area beneath the door when performing the tests. When testing the 3-button wall station, first observe that each button operates the door in the direction indicated and that the STOP button performs that function. With the door stopped at its full open position, the OPEN button should be inoperative. This should be verified and, likewise, the CLOSE button should be inoperative with the door fully closed.

Certain operator control circuits use only a single button or a two button control station and may be designed to function differently than the more common three-button circuit described above. Test the controls in accordance with the description of operation as indicated on the wiring diagram and as selected on pages 14, 15, and 16, Operating & Set-Up Modes.

Observe the door when traveling in each direction for smoothness of operation. Test the setting of the clutch by restraining the door by hand. The clutch should slip. Re-check the limit settings. The door should close tightly at the floor without excessive impact. Likewise, it should fully clear the door opening without the carrier striking the stops on the rail.

The AU-S series operators are equipped with a reversing edge circuit and to conform with code, need to be connected to a pneumatic or foam door edge or photoelectric device. To test an edge for proper reversal, place an object beneath the leading edge of the door. To test a photoelectric device for proper reversal, start the door down and obstruct the beam. The door



CAUTION

DO NOT STAND UNDER DOOR TO TEST REVERSING EDGE USE A CORRUGATED BOX OR OTHER SIMILAR OBJECT

should instantly reverse when it comes into contact with the object provided the height of the object exceeds the cut out point built into the close limit switch (approx. four (4) inches).

If the operator is equipped with other means of control, such as additional 3 button stations or radio controls, each of these should be tested separately for proper operation.

Test the manual disconnect with the door in the fully closed position. The door arm should freely fall away from the carrier when the release chain is pulled. If it is difficult to release and the door arm appears to be under compression, reset the CLOSE limit slightly to reduce the travel of the carrier in the close direction.



WARNING

ALWAYS DISCONNECT POWER TO THE OPERATOR BEFORE SERVICING, CONNECTING ACCESSORY DEVICES OR MAKING ADJUSTMENTS.

MAINTENANCE

Normally, very little maintenance is required. A monthly visual inspection must be made for loose or missing hardware and for excessive slack in the V-Belt and drawbar chain. The clutch must be tested periodically and adjustments made if necessary (see page 18). The brake (where applicable) is adjusted at the factory and will need periodic adjustment for wear. When adjustment becomes necessary see **Figure 21** on page 16 for the adjustment procedure.

Test the reversing edge circuit at least once a month by permitting the door to contact an obstruction while closing. To test a pneumatic or foam door edge for proper reversal, place an object beneath the leading edge of the door. To test a photoelectric device for proper reversal, start the door down and obstruct the beam. The door should instantly reverse when it comes into contact with the object provided the height of the object exceeds the cut out point built into the close limit switch (approx. four (4) inches).



CAUTION

DO NOT STAND UNDER DOOR TO TEST REVERSING EDGE USE A CORRUGATED BOX OR OTHER SIMILAR OBJECT

Lubrication of the operator is not required. It is important, for trouble free service from the operator, that the door be kept free from binding, properly counter balanced and periodically lubricated. **An annual inspection of the door by a qualified overhead door professional is recommended.**

Warning: Repairs and adjustments to the door and operator should be performed only by someone qualified to service commercial overhead doors and operators.

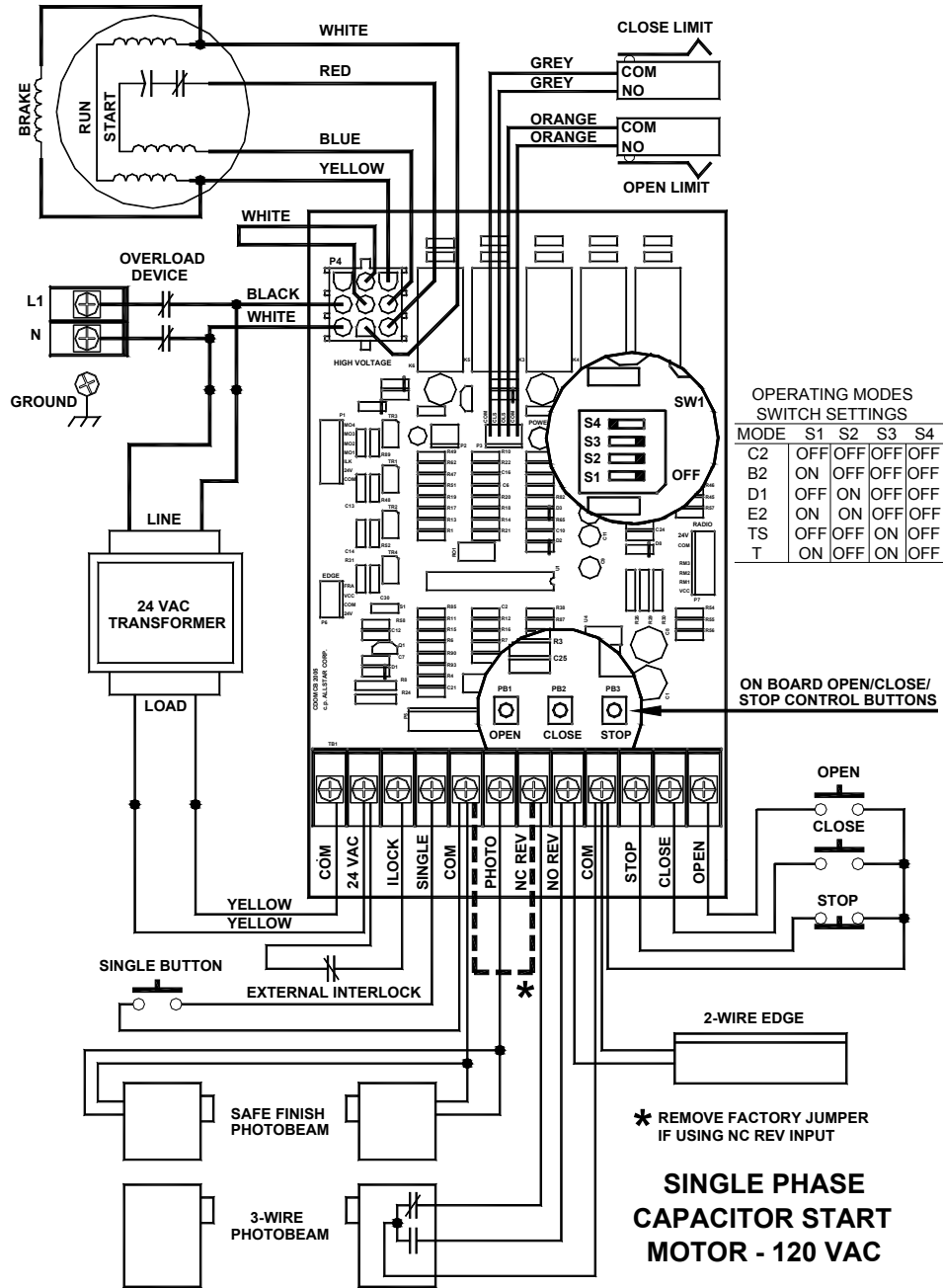

MOTOR WIRING CHART

CDO OPERATORS WITH CDO-MCB MOTOR CONTROL SYSTEM

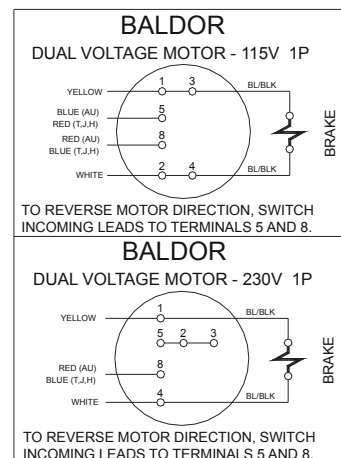
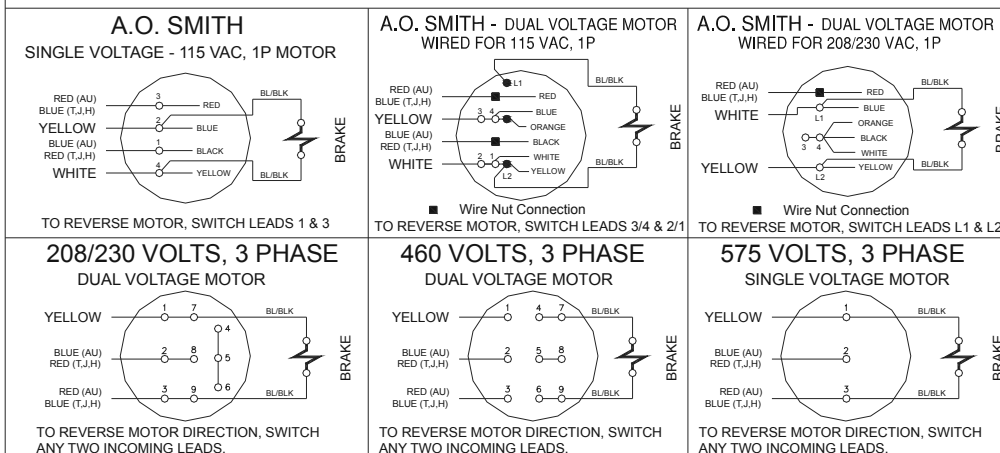

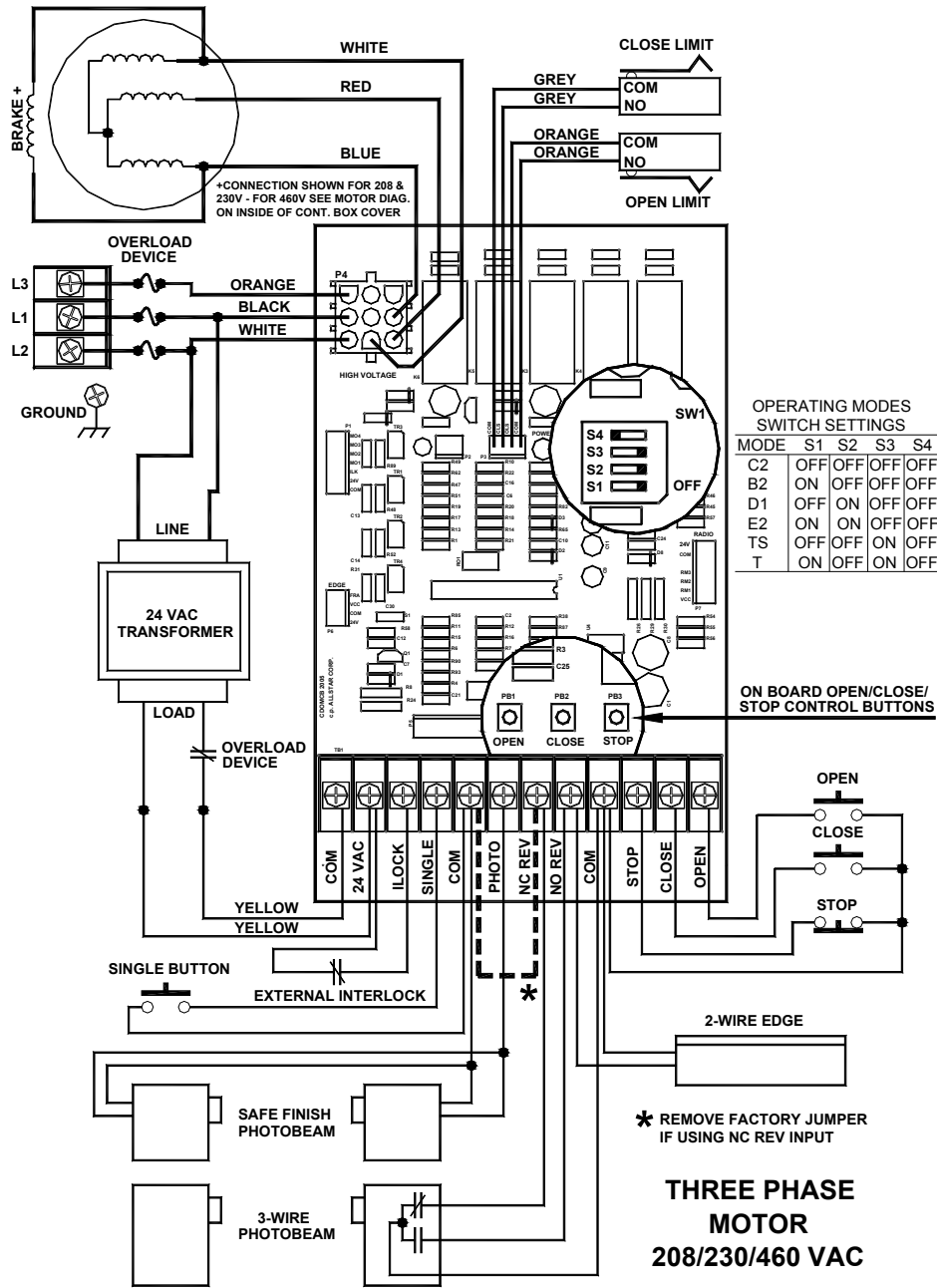

MOTOR WIRING CHART

CDO OPERATORS WITH CDO-MCB MOTOR CONTROL SYSTEM

<p>A.O. SMITH SINGLE VOLTAGE - 115 VAC, 1P MOTOR</p> <p>TO REVERSE MOTOR, SWITCH LEADS 1 & 3</p>	<p>A.O. SMITH - DUAL VOLTAGE MOTOR WIRED FOR 115 VAC, 1P</p> <p>Wire Nut Connection TO REVERSE MOTOR, SWITCH LEADS 3/4 & 2/1</p>	<p>A.O. SMITH - DUAL VOLTAGE MOTOR WIRED FOR 208/230 VAC, 1P</p> <p>Wire Nut Connection TO REVERSE MOTOR, SWITCH LEADS L1 & L2</p>	<p>BALDOR DUAL VOLTAGE MOTOR - 115V 1P</p> <p>TO REVERSE MOTOR DIRECTION, SWITCH INCOMING LEADS TO TERMINALS 5 AND 8.</p>
<p>208/230 VOLTS, 3 PHASE DUAL VOLTAGE MOTOR</p> <p>TO REVERSE MOTOR DIRECTION, SWITCH ANY TWO INCOMING LEADS.</p>	<p>460 VOLTS, 3 PHASE DUAL VOLTAGE MOTOR</p> <p>TO REVERSE MOTOR DIRECTION, SWITCH ANY TWO INCOMING LEADS.</p>	<p>575 VOLTS, 3 PHASE SINGLE VOLTAGE MOTOR</p> <p>TO REVERSE MOTOR DIRECTION, SWITCH ANY TWO INCOMING LEADS.</p>	<p>BALDOR DUAL VOLTAGE MOTOR - 230V 1P</p> <p>TO REVERSE MOTOR DIRECTION, SWITCH INCOMING LEADS TO TERMINALS 5 AND 8.</p>



FIGURE 24 - OPERATOR DIMENSIONS

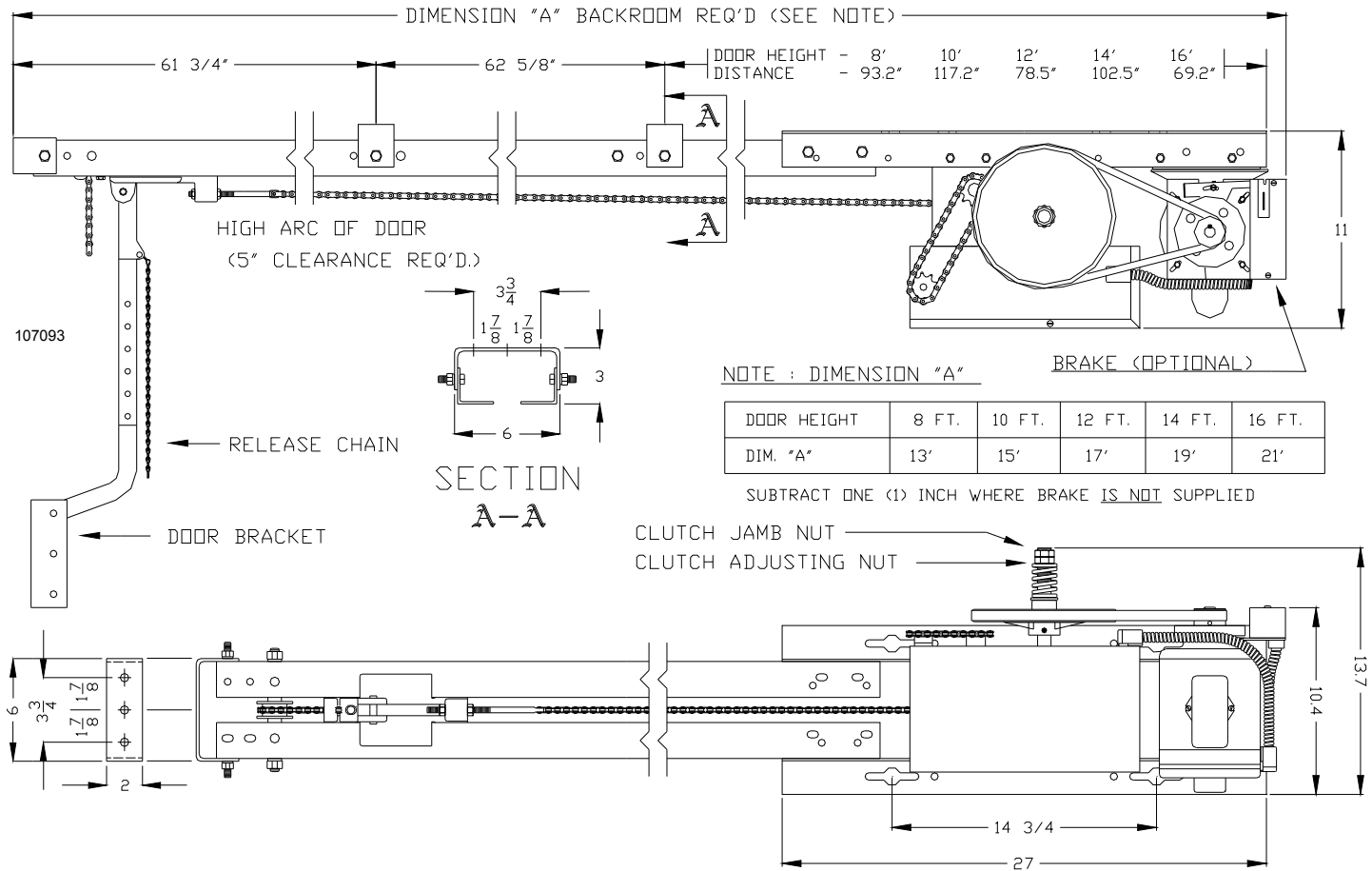

NOTES

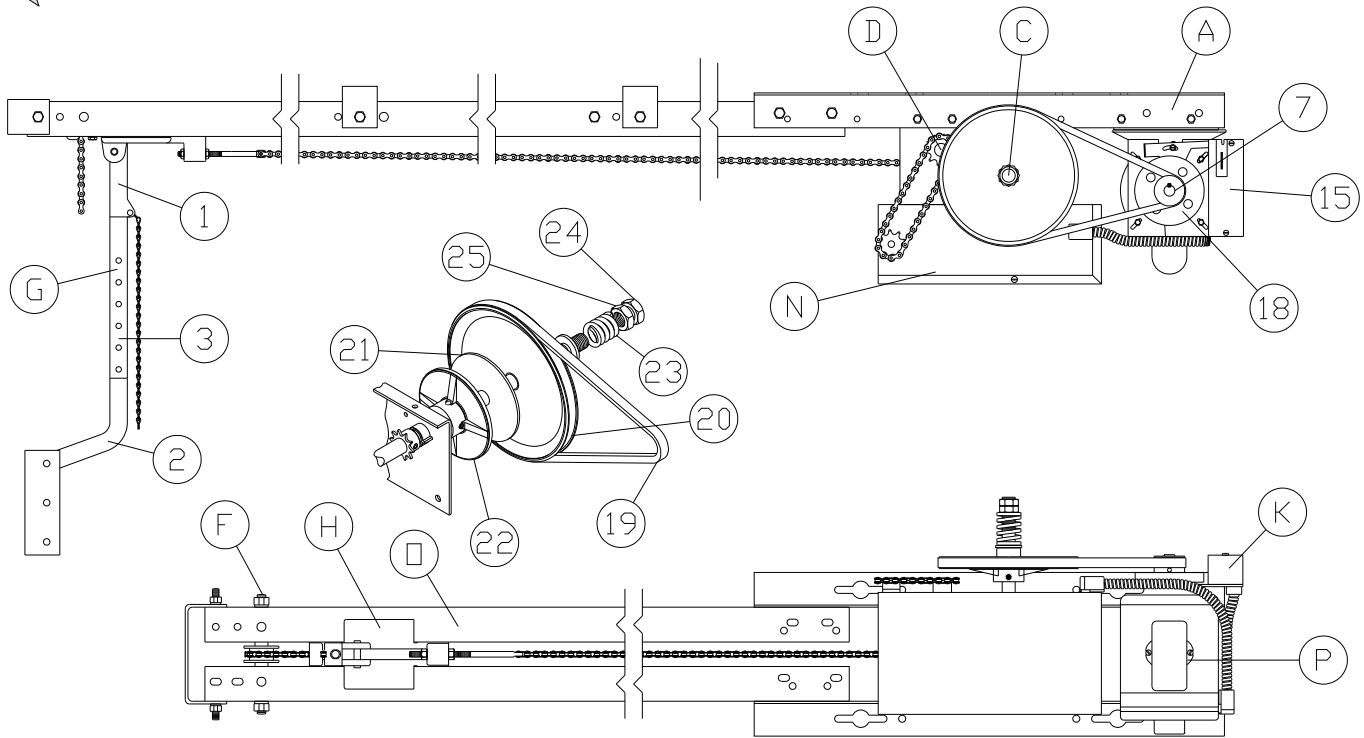

Ref Part # Description

Assemblies

A	106798	Frame Assembly w/Shafts, AUD (1/3 HP)
	107412	Frame Assembly w/Shafts, AUD (1/2 & 3/4 HP)
C	110075	Clutch Shaft Assembly, AUD
D	109848	Drive Shaft Assembly, AUD (1/3 HP)
	110078	Drive Shaft Assembly, AUD (1/2 & 3/4 HP)
F	106265	Front Idler Assembly
G	100174	Door Arm Assembly
H	100512	Trolley Assembly
		Brake standard on 1/2 & 3/4 HP, optional on 1/3 HP
K	109273	Brake Assembly, AUD, 115 VAC
	109274	Brake Assembly, AUD, 230 VAC (also used on 460 VAC)
N	Call	Control Box Assembly
O	Call	Track and Chain Packages

Motors

P	100465	Motor, 1/3 HP, 48 Frame, ODP, 115 VAC, 1 Phase
	100466	Motor, 1/2 HP, 48 Frame, ODP, 115 VAC, 1 Phase
	005156	Motor, 1/3 HP, 56 Frame, ODP, 115/230 VAC, 1 Phase
	005026	Motor, 1/2 HP, 56 Frame, ODP, 115/230 VAC, 1 Phase
	005027	Motor, 3/4 HP, 56 Frame, ODP, 115/230 VAC, 1 Phase
	005183	Motor, 1/3 HP, 56 Frame, ODP, 230/460 VAC, 3 Phase
	005184	Motor, 1/2 HP, 56 Frame, ODP, 230/460 VAC, 3 Phase
	005038	Motor, 3/4 HP, 56 Frame, ODP, 230/460 VAC, 3 Phase

Ref Part # Description

Parts

1	100513	Straight Arm with Disconnect
2	108877	Curved Arm
3	100236	Arm Extension (2 Required)
4	008071	Flange Bearing, 3/4" ID
5	105549	Snap Ring, 3/4"
7	009044	Motor Pulley, 4L
8	106814	Sprocket, 65B10, 3/4" Bore
9	106815	Sprocket, 65B27, 3/4" Bore
10	100314	Sprocket, 41B10, 3/4" Bore
12	009244	Limit Chain, #65, 18" with Master Link
13	107144	Primary Chain, #65, 17" with Master Link
15	105385	Brake Solenoid, 115 VAC
	105386	Brake Solenoid, 230 VAC (also used on 460 VAC)
17	110042	Brake Shoe
18	106806	Brake Drum with 4L Pulley, 5/8" Bore
19	009087	V Belt, 4L350
20	009155	Clutch Pulley with Bushing, 4L
21	009028	Clutch Fiber Disk
22	100133	Clutch Plate
23	105308	Clutch Spring
24	100636	Clutch Lock Nut
25	107517	Clutch Adjusting Nut

SPECIFICATIONS

24

MODEL : AUD____S HP:_____

VOLTS : _____ PHASE : _____

- * UL AND CANADIAN UL LISTED
- * HIGH STARTING TORQUE, CONTINUOUS DUTY MOTOR
- * MOTOR OVERLOAD PROTECTION
- * CLASS 2 (24 VOLT) CONTROL CIRCUIT
- * SOLENOID BRAKE (STANDARD ON 3/4 HP, OPTIONAL ON 1/3 HP AND 1/2 HP)
- * SOLID STATE MOTOR CONTROL CIRCUITRY WITH ADVANCED OPERATIONAL FEATURES STANDARD
- * THREE BUTTON CONTROL: OPEN, CLOSE, STOP
- * WIRED TO ACCEPT REVERSING EDGE INPUT
- * HEAVY GAUGE, POWDER-COATED STEEL FRAME RAILS AND CONTROL BOX
- * ALL SPROCKETS AND PULLEYS PINNED OR KEYED, SOLID STEEL DRIVE SHAFTS
- * FULLY ADJUSTABLE FRICTION CLUTCH
- * MANUAL DOOR DISCONNECT
- * FULLY ADJUSTABLE, INTERNAL, SHAFT DRIVEN LIMITS

Manufacturer's Limited Warranty

Linear LLC warrants its Allstar brand commercial door operators to be free from defect in material and workmanship for a period of two (2) years from the date of purchase. To obtain service contact your dealer.

To obtain service under this warranty the buyer must obtain authorization instructions for the return of any goods from Linear before returning the goods. The goods must be returned with complete identification, with copy of proof-of-purchase, freight prepaid and in accordance with Linear's instructions or they will not be accepted. In no event will Linear be responsible for goods returned without proper authorization or identification.

Goods returned to Linear for warranty repair within the warranty period, which upon receipt by Linear are confirmed to be defective and covered by this limited warranty, will be repaired or replaced at Linear's sole option, at no cost and returned pre-paid. Defective parts will be repaired or replaced with new or factory rebuilt parts at Linear's sole option.

This limited warranty does not cover non-defect damage, damage caused by unreasonable use, damage caused by improper installation or care, vandalism or lightning, fire or excessive heat, flood or other acts of God (including, but not limited to misuse, abuse or alterations, failure to provide reasonable and necessary maintenance), labor charges for dismantling or reinstalling a repaired or replaced unit, or replacement batteries.

These warranties are in lieu of all other warranties, either expressed or implied. All implied warranties of merchantability and/or fitness for a particular purpose are hereby disclaimed and excluded. Under no circumstances shall Linear be liable for consequential, incidental or special damages arising in connection with the use or inability to use this product. In no event shall Linear's liability for breach of warranty, breach of contract, negligence or strict liability exceed the cost of the product covered hereby. No person is authorized to assume for Linear any other liability in connection with the sale of this product.

This warranty gives you specific legal rights. You may also have other rights which vary from state to state. Warranty effective after October 1st 2007.

For Information:

877-441-9300 800-421-1587 www.allstarcorp.com

**This Door Operator is built in the USA and
complies with all requirements of
ANSI/UL Standard 325.**