

DYNAMIC SERIES

Part D: ARX receiving unit



INDEX

1	Description	2
1.1	Safety functions of the ARX receiving unit	3
2	Technical data	3
3	Technical data sheet	3
4	Plates	4
5	Light signals	4
5.1	POWER LED (green)	4
5.2	ALARM LED (red)	5
5.3	STATUS LED (blue)	5
5.4	SETUP LED (yellow)	5
6	Values of proportional outputs	6
6.1	Calibrating maximum and minimum values of proportional outputs	7
6.2	Calibrating values related to the rest position of proportional outputs (offset) ...	8
6.3	Inversion of movement direction of the joystick's axis	8
6.4	Restoring factory settings	9
7	Malfunction signalled by the receiving unit	10

1 Description

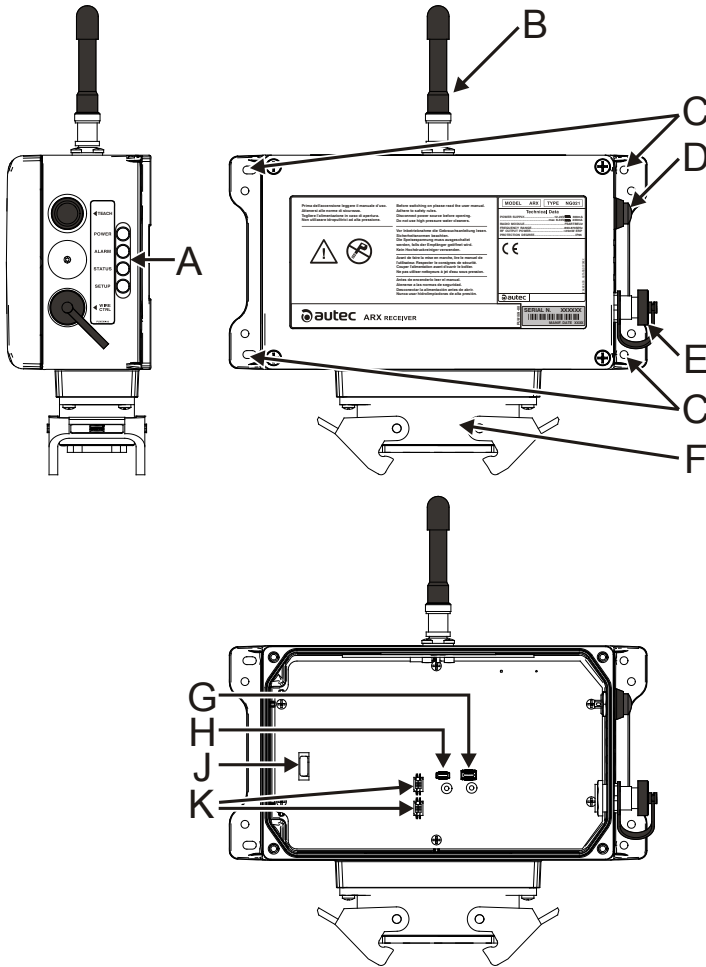

A	LEDs
B	antenna
C	mounting holes
D	TEACH pushbutton
E	connector for cable control

F	plug
G	DTK connector (for memory board)
H	IDK (for address key)
J	fuse F1
K	DIP switches

The receiving unit communicates with the machine through the output and the corresponding wiring.

1.1 Safety functions of the ARX receiving unit

The SO1 and SO2 outputs may be either STOP (stop function) or SAFETY outputs (UMFS function), according to the configuration of the receiving unit (see technical data sheet). If they are configured as STOP outputs the UMFS safety function is not available. If they are configured as SAFETY outputs both the UMFS and stop safety functions are available.

2 Technical data

Power supply	8-30V $\overline{=}$
Antenna	dedicated
Rated current of the SO1 and SO2 outputs	2A (30V $\overline{=}$)
Rated current of digital outputs	2A (30V $\overline{=}$)
Rated current of analogue outputs (PWM)	2A (30V $\overline{=}$)
Rated current of analogue outputs (voltage)	10mA (28V $\overline{=}$)
Protection of outputs (fuse F1)	10A (32V $\overline{=}$, autofuse)
Housing material	PA6 (20% fg)
Protection degree	IP66 (NEMA 4)
Dimensions	202x123x83mm (7.95x4.84x3.23In)
Weight	1.2kg (2.7Lb)

3 Technical data sheet

The technical data sheet contains the wiring diagram showing the connection between the receiving unit and the machine. It also contains the transmitting unit configuration and shows the matching between commands sent and machine functions/movements. Each technical data sheet must be filled in, checked and signed by the installer, who is responsible for a correct wiring. A copy of the technical data sheet must always be kept together with this manual (always keep a copy of this data sheet for administrative purposes).

 WARNING	<p>The wiring of the receiving unit outputs must always reflect the wiring indicated in the technical data sheet.</p>
--	--

4 Plates

The receiving unit has the following plates:

Plate	Position	Content
radio remote control identification plate	On the cover of the receiving unit	Radio remote control serial number (S/N), bar code and manufacturing year.
technical data plate	On the cover of the receiving unit	MODEL, TYPE and main receiving unit technical data, marking and possible radio remote control marks.

5 Light signals

The receiving unit ARX has four LEDs:

- POWER is green
- ALARM is red
- STATUS is blue
- SETUP is yellow

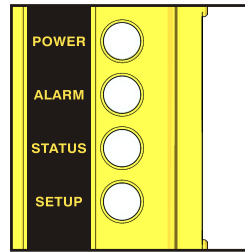

5.1 POWER LED (green)

The POWER LED indicates the status of the receiving unit and of the radio link.

The POWER LED...	Meaning
...is off	The receiving unit is switched off.
...is on	The receiving unit is powered and there is no radio link.
... blinks	The receiving unit is powered and radio link has been built.

5.2 ALARM LED (red)

The ALARM LED warns about anomalies in the receiving unit.

The ALARM LED...	Meaning
...is off	The receiving unit works correctly.
... blinks once	Error on the STOP outputs.
... blinks twice	Error on the SAFETY outputs.
... blinks three times	Error on the outputs corresponding to direction commands.
... is on	Configuration error on the SO1 and SO2 outputs.

5.3 STATUS LED (blue)

The STATUS LED warns about anomalies on the outputs or on the power supply and indicates the reception of data from the transmitting unit.

The STATUS LED...	Meaning
...is off	No radio link.
... blinks slowly	Over-voltage on power supply.
... blinks fast	The receiving unit receives data from the transmitting unit.
... is on	Over-current in one of the PWM analogue outputs.

5.4 SETUP LED (yellow)

The SETUP LED shows the status of the data memory and of the address key, depending on the receiving unit's working status.

The SETUP LED...	Meaning
...is off	The receiving unit works correctly.
... blinks once	Error on the address key.
... blinks twice	Error on the memory board.

The SETUP LED...	Meaning
... blinks quickly three times	The receiving unit is saving data set with the REMOTE SETUP procedure (see chapter 6).
... blinks four times	Inversion of movement direction of the joystick's axis is being performed within the REMOTE SETUP procedure (see paragraph 6.3).
... blinks fast	Within the REMOTE SETUP procedure: - two or more analogue commands are being activated simultaneously or - factory settings are being restored (see paragraph 6.4)
... is on	Calibration of maximum and minimum values of proportional outputs is being performed within the REMOTE SETUP procedure (see paragraph 6.1).

6 Values of proportional outputs

Proportional outputs in the ARX receiving unit are factory set: values are given in the technical data sheet.

The REMOTE SETUP procedure is used to modify:

- maximum and minimum values of proportional outputs (see paragraph 6.1)
- rest position values related to the proportional outputs (offset) (see paragraph 6.2)
- movement direction of the joystick's axis (see paragraph 6.3)



The REMOTE SETUP procedure can only be performed by skilled and properly trained personnel.



During the REMOTE SETUP procedure, pay particular attention to the machine behaviour, as it moves as a response to acting on the actuators.



The REMOTE SETUP procedure is used to modify one proportional output at a time. The procedure will not be performed if the actuators corresponding to the other proportional outputs are not in the rest position.

If necessary, it is possible to restore factory settings at any time (see paragraph 6.4).

6.1 Calibrating maximum and minimum values of proportional outputs

1. Start up the radio remote control.
2. Press the TEACH pushbutton in the receiving unit and do not release it until the SETUP LED illuminates.
3. Set the desired values as follows:
 - To set the maximum value, move the joystick to the maximum range of the semi-axis to be calibrated. Maintain the position and use the TEACH selector on the transmitting unit to set the desired value.
 - To set the minimum value, move the joystick slightly out of the rest position of the semi-axis to be calibrated. Maintain the position and use the TEACH selector on the transmitting unit to set the desired value.
 - After calibrating one joystick, press the STOP pushbutton to save calibrations. Calibrations are saved in the data memory on the DTK connector.
4. To set other values, unlock the STOP pushbutton, press the START pushbutton and repeat actions described in the previous point.
5. To leave the procedure, press the TEACH pushbutton on the receiving unit and do not release it until the SETUP LED switches off.



If the proportional outputs are activated by actuators that are not joysticks (i.e. potentiometer, switch), calibrate maximum and minimum values according to the above mentioned procedure.

If a speed selector is present on the transmitting unit, minimum and maximum values have to be calibrated for each of the selector positions.

If inputs are used in the receiving unit to select different speeds, calibration must be performed for any possible configuration of the inputs.

6.2 Calibrating values related to the rest position of proportional outputs (offset)

1. Start up the radio remote control.
2. Press the TEACH pushbutton in the receiving unit and do not release it until the SETUP LED illuminates.
3. Enable and release the TEACH + command of the corresponding switch on the transmitting unit and press and release the START pushbutton within one second.
4. Repeat actions described in the previous point until the SETUP LED on the receiving unit starts blinking three times.
5. Set the desired values as follows:
 - Move the joystick out of the rest position of the axis to be calibrated. Maintain the position and use the TEACH selector on the transmitting unit to set the desired value.
 - After calibrating one joystick, press the STOP pushbutton to save calibrations. Calibrations are saved in the data memory on the DTK connector.
6. To set other values, unlock the STOP pushbutton, press the START pushbutton and repeat actions described in the previous point.
7. To leave the procedure, press the TEACH pushbutton on the receiving unit and do not release it until the SETUP LED switches off.



If the proportional outputs are activated by actuators that are not joysticks (i.e. potentiometer, switch), calibrate values related to the rest position according to the above mentioned procedure.

6.3 Inversion of movement direction of the joystick's axis

1. Start up the radio remote control.
2. Press the TEACH pushbutton in the receiving unit and do not release it until the SETUP LED illuminates.
3. Enable and release the TEACH + command of the corresponding switch on the transmitting unit and press and release the START pushbutton within one second.
4. Repeat actions described in the previous point until the SETUP LED on the receiving unit starts blinking four times.
5. Set the desired values as follows:
 - Move the joystick out of the rest position of the axis to be calibrated. Maintain this position and activate once the TEACH + command related to the corresponding switch on the transmitting unit.
 - After calibrating one joystick, press the STOP pushbutton to save calibrations. All calibrations are saved in the memory board.
6. To invert other directions, unlock the STOP pushbutton, press the START pushbutton and repeat actions described in the previous point.
7. To leave the procedure, press the TEACH pushbutton on the receiving unit and do not release it until the SETUP LED switches off.

6.4 Restoring factory settings

This procedure is used to restore factory settings for the proportional outputs.

1. Ensure that the transmitting unit is switched off.
2. Power on the receiving unit.
3. Press the TEACH pushbutton in the receiving unit and do not release it until the SETUP LED illuminates.
4. Press the TEACH pushbutton three times and do not release it at last pressure; the SETUP LED blinks fast: this indicates that factory settings are being restored.
5. Release the TEACH pushbutton when the SETUP LED is steadily illuminated again. If the TEACH pushbutton is released before the SETUP LED is steadily illuminated, factory settings of proportional outputs will not be restored.
6. To leave the procedure, press the TEACH pushbutton on the receiving unit and do not release it until the SETUP LED switches off.

7 Malfunction signalled by the receiving unit

Use the light signals on the receiving unit to identify the radio remote control malfunction. If the problem persists after the suggested solution has been carried out, contact the support service of the machine manufacturer.

Signals	Possible reason	Solutions
The POWER LED is off.	The receiving unit is switched off.	Disconnect the power supply and restore it after 5 minutes to make sure that a restorable thermal fuse integrated in the receiving unit has not been activated. Correctly plug in the connecting plug and power on the receiving unit.
The POWER LED is on.	No radio link.	Bring the transmitting unit close to the receiving unit.
The ALARM LED blinks once.	Error on the STOP outputs.	Make sure that fuse F1 is intact. Correctly plug in the connecting plug. Make sure that the STOP outputs are wired correctly.
The ALARM LED blinks twice.	Error on the SAFETY outputs.	Make sure that fuse F1 is intact. Correctly plug in the connecting plug. Make sure that the SAFETY outputs are wired correctly.
The ALARM LED blinks three times.	Error on the outputs corresponding to direction commands.	Contact the support service of the machine manufacturer. Make sure that the outputs of direction commands are wired correctly.
The ALARM LED is on.	Configuration error on the SO1 and SO2 outputs.	Make sure that the DIP switches are set as on the technical data sheet. If this signal persists, contact the support service of the machine manufacturer.

Signals	Possible reason	Solutions
The STATUS LED blinks slowly.	Over-voltage on power supply.	Make sure that the receiving unit power supply is within the voltage limits provided in the technical data.
The STATUS LED blinks fast and irregularly.	The receiving unit loses some data sent by the transmitting unit.	Bring the transmitting unit close to the receiving unit. If this signal persists, contact the support service of the machine manufacturer.
The STATUS LED is on.	Over-current in one of the PWM analogue outputs.	Contact the support service of the machine manufacturer.
The SETUP LED blinks once.	Error on the address key.	Contact the support service of the machine manufacturer.
The SETUP LED blinks twice.	Error on the memory board.	Contact the support service of the machine manufacturer.
The SETUP LED blinks quickly.	Two or more analogue commands are being activated simultaneously within the REMOTE SETUP procedure.	Check actuators on the transmitting unit and activate one single analogue command.

