User Manual

Trademark

Autel®X-Memo™ is the trademark of Autel Intelligent Technology Corp., Ltd., registered in China, the United States and other countries. All other marks are trademarks or registered trademarks of their respective holders.

Copyright Information

No part of this manual may be reproduced, stored in a retrieval system or transmitted, in any form or by any means, electronic, mechanical, photocopying, recording, or otherwise, without the prior written permission of Autel.

Disclaimer of Warranties and Limitation of Liabilities

All information, specifications and illustrations in this manual are based on the latest information available at the time of printing. Autel reserves the right to make changes at any time without notice. While information of this manual has been carefully checked for accuracy, no guarantee is given to the completeness and correctness of the contents, including but not limited to the product specifications, functions, and illustrations.

Autel will not be liable for any direct damages or for any special,

incidental, or indirect damages or for any economic consequential damages (including lost profits).

IMPORTANT: Before operating or maintaining this unit, please read this manual carefully, paying extra attention to the safety warnings and precautions.

Service Info



<http://pro.autel.com>

www.autel.com



1-855-288-3587/1-855-AUTELUS (North America)

0086-755-86147779 (China)



Support@autel.com

For technical assistance in all other markets, please contact your local selling agent.

Safety Information

Safety Information

For your own safety and the safety of others, and to prevent damage to the X-memo camera, it is important that the safety instructions herein presented throughout this manual be read and understood by the user.



Exercise caution when using the batteries. Batteries may leak or explode if products with batteries are not properly handled. Handle with extra care in the following situations to avoid a battery explosion or fire:

- Do not use the camera or the battery if damage is observed - for example, if cracked, punctured or damaged by water.
- Do not disassemble, bend or deform, puncture or shred.
- Do not dry camera or battery with an external heat source such as hair dryer or microwave oven.
- Do not put the camera or battery in damp environment. Secure the camera and battery with the provided housing.
- Do not turn on the camera if it is wet. If the camera is already on, turn it off and remove the battery immediately. Allow the camera to dry thoroughly before use again.
- Always use brand name or good quality charger to secure safe charging.
- Apply to clean and smooth surface when attaching the adhesive

Safety Information

mounts.

- When operating the camera, always keep hands clean and dry.
- If the camera is over heat, turn it off to cool down the camera.

The safety messages herein cover situations Autel is aware of. Autel cannot know, evaluate or advise you as to all of the possible hazards. You must be certain that any condition or service procedure encountered do not jeopardize your personal safety.

TRADEMARK	II
COPYRIGHT INFORMATION	II
DISCLAIMER OF WARRANTIES AND LIMITATION OF LIABILITIES..	
SAFETY INFORMATION	IV
CHAPTER 1 USING THIS MANUAL	1
1.1 CONVENTIONS	1
1.1.1 <i>Bold Text</i>	1
1.1.2 <i>Terminology</i>	1
1.1.3 <i>Notes and Important Messages</i>	1
1.1.4 <i>Hyperlinks</i>	2
1.1.5 <i>Procedures</i>	2
CHAPTER 2 GENERAL INTRODUCTION	3
2.1 FUNCTIONAL DESCRIPTION	3
2.1.1 <i>LED Indicator Lights</i>	6
2.2 POWER SOURCES	7
2.3 TECHNICAL SPECIFICATIONS	8
2.4 ACCESSORIES KIT	9
CHAPTER 3 GETTING STARTED	11
3.1 UNPACKING THE X-MEMO.....	11
3.2 USING THE MICROSD CARD.....	11
3.2.1 <i>Inserting the MicroSD Card</i>	12
3.2.2 <i>Removing the MicroSD Card</i>	13

3.3	USING THE BATTERY	13
3.3.1	<i>Inserting the Battery</i>	13
3.3.2	<i>Charging the Battery</i>	14
3.3.3	<i>Using the Camera While Charging</i>	14
3.4	ASSEMBLING THE MOUNTS	15
3.5	POWERING UP	16
3.5.1	<i>Screen Layouts</i>	16
3.6	POWERING DOWNS.....	18
CHAPTER 4	CAMERA OPERATIONS.....	19
4.1	CAMERA DEFAULT SETTINGS.....	19
4.2	CAMERA MODES	19
4.2.1	<i>Video</i>	20
4.2.2	<i>Photo</i>	21
4.2.3	<i>Burst Photo</i>	22
4.2.4	<i>Time Lapse</i>	22
4.3	CAMERA SETTINGS.....	23
4.3.1	<i>General Settings</i>	25
4.3.2	<i>Video Settings</i>	28
4.3.3	<i>Photo Settings</i>	29
4.3.4	<i>Capture Settings</i>	30
4.4	PLAYBACK	31
4.5	TRANSFERRING FILES.....	33
CHAPTER 5	X-MEMO APP OPERATIONS	34

5.1	WI-FI CONNECTION	34
5.2	X-MEMO APP	34
CHAPTER 6	MAINTENANCE AND SERVICES	36
6.1	MAINTENANCE INSTRUCTIONS	36
6.2	TROUBLESHOOTING CHECKLIST.....	38
6.3	ABOUT BATTERY USAGE	40
CHAPTER 7	COMPLIANCE INFORMATION.....	42
CHAPTER 8	WARRANTY	43

Chapter 1 Using This Manual

This manual contains device usage instructions.

Some illustrations shown in this manual may contain modules and optional equipment that are not included in your system. Contact your sales representative for availability of other modules and optional tools or accessories.

1.1 Conventions

The following conventions are used.

1.1.1 Bold Text

Bold emphasis is used to highlight selectable items such as buttons and menu options.

Example:

- Tap **OK**.

1.1.2 Terminology

The term “**select**” means highlighting a button or menu item and tapping it to confirm the selection.

1.1.3 Notes and Important Messages

The following messages are used.

Notes

A **NOTE** provides helpful information such as additional explanations, tips, and comments.

Important

IMPORTANT indicates a situation which, if not avoided, may result in damage to the device.

1.1.4 Hyperlinks

Hyperlinks, or links, that take you to other related articles, procedures, and illustrations are available in electronic documents. Blue colored text indicates a selectable hyperlink.

1.1.5 Procedures

An arrow icon indicates a procedure.

Example:

➤ To insert the microSD card

1. Turn off the camera (if powered on).
2. Open the SD card slot from the side of camera.
3. Slide the memory card into card slot with the printing side facing front of camera. Slide gently until it clicks into place.

Chapter 2 General Introduction

The X-Memo™ is a smart action camcorder specially designed to capture still and motion pictures, supporting full HD 1080p60 shoots with a built-in 12MP sensor. Featured by the intuitive UI design and a sensitive capacitive touch screen, this camera is extremely easy to use. The integrated WiFi and X-Memo App make capturing and sharing easily anywhere at any time.

2.1 Functional description

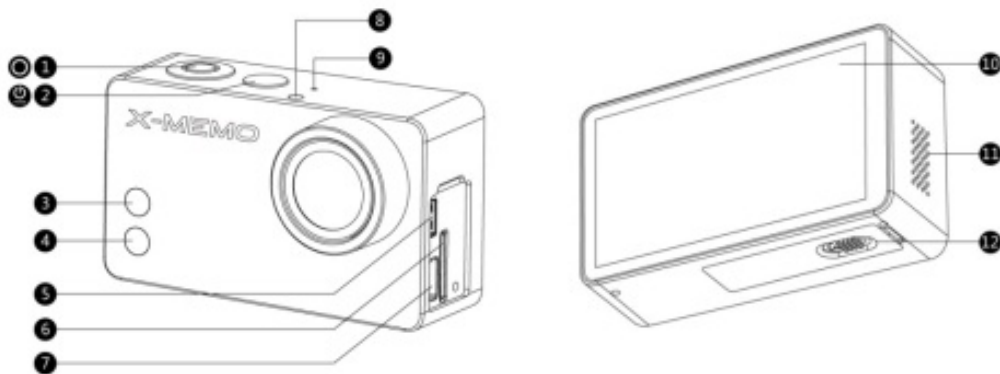

Figure 2-1 Camera Six Side View

- | | |
|------------------------------|------------------------------|
| 1. Shutter/Select Button | 7. Mini USB Port |
| 2. Power/Mode Button | 8. LED Status Light |
| 3. Wi-Fi Status Light (blue) | 9. Microphone |
| 4. Camera Status Light (red) | 10. Touch Screen |
| 5. Micro HDMI Port | 11. Audio Speaker |
| 6. MicroSD Card Slot | 12. Battery Compartment Lock |

Table 2-1 Camera Buttons

Name	Description
1. Shutter/Select Button	Press this button to: A. Take photos or videos. B. Make selections on menus.
2. Power/Mode Button	A. Press this button once to turn on the camera. B. Press and hold for 3 seconds to turn off the camera. C. When the camera is powered on, pressing this button allows you to switch among the camera Modes, the Settings menu and the Playback in sequence.
3. Wi-Fi Status Light (blue)	Indicates the Wi-Fi communication status.
4. Camera Status Light (red)	Indicates the working status of the camera when taking photos or videos.

Name	Description
5. Micro HDMI Port	Connects the camera to a compatible computer monitor, digital television, or video projector for high definition video file transfer.
6. MicroSD Card Slot	Stores camera files.
7. Mini USB Port	Connects the camera to a PC for file transfer.
8. LED Status Light	Synchronizes with the Camera and Wi-Fi Status lights for convenient identification.
9. Microphone	Records sound when taking videos.
10. Touch Screen	Works as the display monitor featuring intuitive touch control.
11. Audio Speaker	Makes alert sounds and plays audios.
12. Battery Compartment Lock	Locks or unlocks the Battery Compartment.

2.1.1 LED Indicator Lights

The table below gives brief definitions of LED Indicator Lights.

Table 2-2 LED Indicator Lights

Indicator Lights	LED Status	Camera Status
Front solid red	ON	<ul style="list-style-type: none"> • Charging
Top and front LEDs flash red and blink 3 times.	ON/OFF	<ul style="list-style-type: none"> • Power On/Off • Formatting • Stop recording
Top and front LEDs flash red and blink once	ON/OFF	<ul style="list-style-type: none"> • Taking a single photo • Taking a burst photo • Taking a series of time lapse photos
Top and front LEDs flash red and blink every Second	ON/OFF	<ul style="list-style-type: none"> • Recording
Top and front LEDs flash blue and blink every second	ON/OFF	<ul style="list-style-type: none"> • Wi-Fi is on
Top and front LEDs flash blue and blink once	OFF	<ul style="list-style-type: none"> • Turn off Wi-Fi

2.2 Power Sources

The X-Memo receives power from any of the following sources:







- AC Charging adapter (1.5 hours for full charging)
- PC USB Port (2 hours for full charging) or other USB devices





2.3 Technical Specifications

Main features	Description
LED	2.45'
Video Resolution	1080P/60fps;960P; 720P;WVGA
Wi-Fi	Built-in Wi-Fi antenna
Maximum Burst Photo	10 photos/ per second
File format	Video: MP4/MOV; Photo: JPEG.
Battery	Rechargeable Li-ion battery (3.8V, 940mAh)
Recharging Time	2 hours by USB 1.5 hours by AC adapter
Waterproof housing	40m
Operating Environment Temperature	-10°C-50°C (14°F-122°F)
System Requirements	Compatible with Windows XP (Service Pack 2 or later) or Vista; Mac OS® X 10.4.11 or later.
SD Card Requirements	Compatible with microSD card (* Storage capacity: from 8GB to 64GB; Class level: 10 speed rating or higher)

2.4 Accessories Kit

Camera Accessories Kit

Image	Qty.	Description
	X1	Waterproof Housing Allows underwater photo-and-video graphing.
	X2	Backdoor <ul style="list-style-type: none"> • Covered (with touchable screen protector, waterproof) • Opened (without cover, not waterproof)
	X1	Camera Battery Rechargeable Li-Po Battery
	X1	Flat Mount
	X1	Curved Mount
	X2	Short Connectors

	X1	Long Connector
	X1	90°C Rotate Connector (long)
	X1	90°C Rotate Connector (Short)
	X1	Connecting Screw (long)
	X2	Connecting Screws (short)

Chapter 3 Getting started

3.1 Unpacking the X-Memo

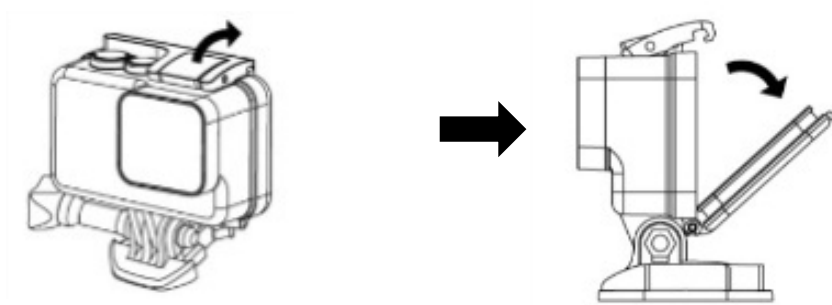

Figure 3-1 *Unpacking the X-Memo*

➤ **To unpack the X-Memo**

1. Lift the front latch up to release the camera housing.
2. Pull to open the backdoor and take out the camera.

3.2 Using the MicroSD Card

The X-Memo camera is compatible with microSD, microSDHC and microSDXC memory cards, of which storage capacity ranges from 8GB to 64GB. You must use a microSD card with class level 10 or higher. Important MicroSD card messages are shown below.

Message	Description
NO SD	No card in camera. A microSD card is required.

SD Full	Memory card is full. Delete files or swap card.
SD Error	Camera unable to read card.

3.2.1 Inserting the MicroSD Card



Figure 3-2 *Inserting the MicroSD Card*

➤ **To insert the microSD card**

1. Turn off the camera (if powered on).
2. Open the SD card slot from the side of camera.
3. Slide the memory card into card slot with the printing side facing front of camera. Slide gently until it clicks into place.

3.2.2 Removing the MicroSD Card



Figure 3-3 *Removing the MicroSD Card*

➤ **To remove the microSD card**

1. Turn off the camera (if powered on).
2. Open the SD card slot from the side of camera.
3. Place fingernail on the edge of the card and gently press further into camera.
4. The card will be ejected to be removed.

3.3 Using the Battery

3.3.1 Inserting the Battery

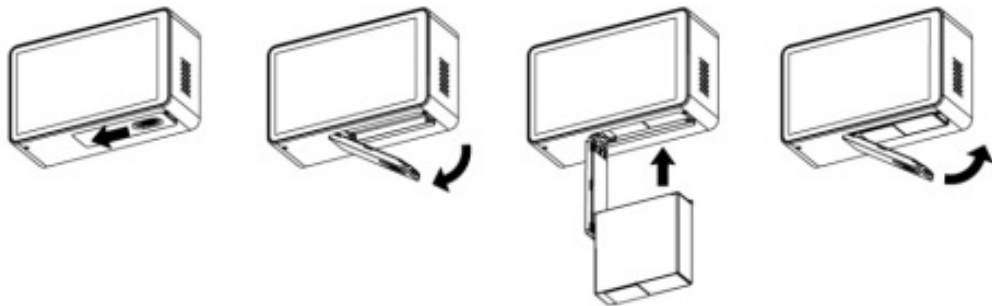

Figure 3-4 *Inserting the Battery*

➤ **To insert the battery**

1. Slide to unlock the battery compartment.
2. Insert the supplied battery with the arrow side facing the LCD screen.
3. Slide back to lock the battery compartment.

3.3.2 Charging the Battery

The red battery icon will be displayed on the camera's LCD when the battery drops below 4%. When battery is close to shutdown level during recording, the camera will save the file and then turn **OFF**.

➤ **To charge the battery**

1. Press **Power/Mode** button and hold for 3 seconds to turn **OFF** your camera.
2. Connect the camera to your computer or any USB devices via USB cable. **Camera Status Light** shows solid Red while charging.
3. Red **Camera Status Light** will turn **OFF** when charging is complete.

3.3.3 Using the Camera While Charging

You can shoot photos or videos while charging the camera's battery with an AC adapter. When the camera is connected to a PC, it only allows charging and transferring files.

3.4 Assembling the Mounts

The X-Memo provides thumb screw, quick release buckle and housing for users to quickly assemble a complete unit.

➤ **To assemble a complete unit**

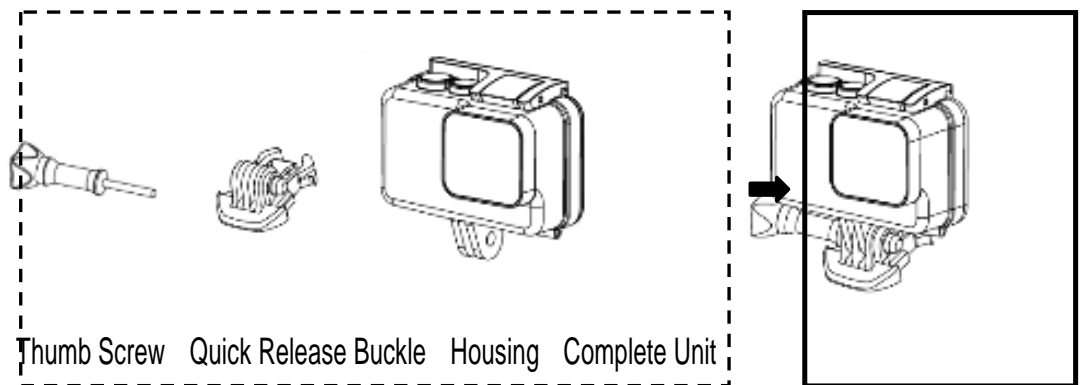

Figure 3-5 *Assembling a complete unit*

With the assembled complete unit, the curved and flat adhesive mounts allows you to easily attach your camera to flat or curved surfaces of helmets, gear and vehicles.

➤ **To attach flat or curved adhesive mounts**

Slide the adhesive mounts to connect the camera housing as shown in the picture.



Flat Adhesive Mount

Curved Adhesive Mount

Figure 3-6 *Attaching adhesive mounts*

➤ **To remove flat or curved adhesive mounts**

Use a hair dryer to heat the mount and then remove it.

NOTE: Attach the adhesive mounts at least 24 hours in advance of use. Follow the requirements below:

Apply to smooth surfaces. Avoid porous or abrasive surfaces, which will reduce adhesion.

Apply to clean surfaces. Remove heavy dirt, oil, wax or other debris that will reduce adhesion.

Operate in room temperature. Avoid cold or damp environment that will reduce adhesion.

3.5 Powering Up

Press once the **Power/Mode** button. The red **Camera Status Lights** flash three times and the **Sound Indicator** plays a ringtone.





3.5.1 Screen Layouts

After powering up your camera for the first time, the screen displays the default video mode as below.



Figure 3-7 *Default Video Mode*

Table 3-1 *Default Video Mode Buttons*

Function	Button	Description
Video Resolution	1080/30 WIDE	1080p/30 frame per second; Wide angle.
Recording Time	00:00:00/ 02:38:56	Shows used recording time / Shows available recording time.
Wi-Fi		Shows Wi-Fi connectivity (Wi-Fi on or off).
Memory Capacity		Shows usable memory capacity.
Battery		Shows battery capacity status.
Thumbnail		Shows the thumbnail of current file.
Settings		Allows to adjust camera settings.

See [4.2 Camera Modes](#) for instructions on how to set the mode.

NOTE: When turning on your camera again, the LCD screen will display the last setting record.

3.6 Powering Downs





Press the **Power/Mode** button and hold for 3 seconds. The red **Camera Status Lights** flash three times and the Sound Indicator plays a ringtone.

Chapter 4 Camera Operations

4.1 Camera Default Settings

The table below provides a brief description of the camera default settings.

Table 4-1 *Camera Default Settings Buttons*

Main Features	Button	Description
Video Resolution		1080P (16:9)
Photo Resolution		12M
Burst Photo		10 photos in 1 second
Time Lapse		5 seconds
Wi-Fi		OFF

4.2 Camera Modes







Press the **Power/Mode** button to cycle through the modes. The following six camera modes appear in the same sequence as the table below. After one mode is set, you can adjust the settings of that mode by tapping  at the upper right of screen.

Table 4-2 Camera Modes Buttons

Mode	Button	Description
Video		Records Video .
Photo		Captures a single Photo .
Burst Photo		Captures up to 10 photos in one second.
Time Lapse		Captures a series of Photos at defined intervals.
Settings		Adjusts camera settings including general, video, photo and capture settings.
Playback		View the files in camera.

4.2.1 Video

The **Video** icon will be displayed on LCD screen in video mode. If not, press the **Power/Mode** button to cycle through different modes.

➤ **To start recording**

Press the **Shutter/Select** button or tap the **Video** button

onscreen. The red **Camera Status Lights** flash every second while recording.

➤ **To stop recording**

Press the **Shutter/Select** button or tap the **Video** button onscreen. The red **Camera Status Lights** flash three times before stopping recording.

NOTE: When your camera is running out of power, the files will be automatically saved before the camera powers off.

See [4.3.2 Video Settings](#) menu and [4.3.4 Capture Settings](#) menu for more details.

4.2.2 Photo

The **Photo** icon will be displayed on LCD screen in photo mode. If not, press the **Power/Mode** button to cycle through different modes.

➤ **To take a Photo**

Press and release the **Shutter/Select** button or tap the **Photo** button onscreen. The camera clicks and the red **Camera Status Lights** flash when taking each photo.

See [4.3.3 Photo Settings](#) menu and [4.3.4 Capture Settings](#) menu for more setting details.

4.2.3 Burst Photo

The **Burst Photo** icon will be displayed on LCD screen in photo burst mode. If not, press the **Power/Mode** button to cycle through different modes. In **Burst Photo** mode, you can capture a series of photos at various speeds including 3 photos/1 second, 5 photos/1 second, 8 photos/1 second and 10 photos/1 second (default).

➤ **To Start Burst Photo**

Press and release the **Shutter/Select** button or tap the **Burst Photo** button onscreen. The camera clicks and the red **Camera Status Lights** flash when taking each burst photo.

See [4.3.3 Photo Settings](#) menu and [4.3.4 Capture Settings](#) menu for more details.

4.2.4 Time Lapse

The **Time Lapse** icon will be displayed on LCD screen in time lapse mode. If not, press the **Power/Mode** button to cycle through different modes. In **Time Lapse** mode, you can capture photos with various defined time intervals, including 0.5, 1, 2, 5 (default), 10, 30 and 60 seconds.

➤ **To start Time Lapse**

Press the **Shutter/Select** button or tap the **Time Lapse** button onscreen. The camera clicks, while the red **Camera Status Lights** blink.

➤ **To stop Time Lapse**

Press the **Shutter/Select** button or tap the **Time Lapse** button onscreen.

See [4.3.3 Photo Settings](#) menu and [4.3.4 Capture Settings](#) menu for more details.

4.3 Camera Settings

The X-Memo camera allows four kinds of camera settings as detailed in the figure and table below.

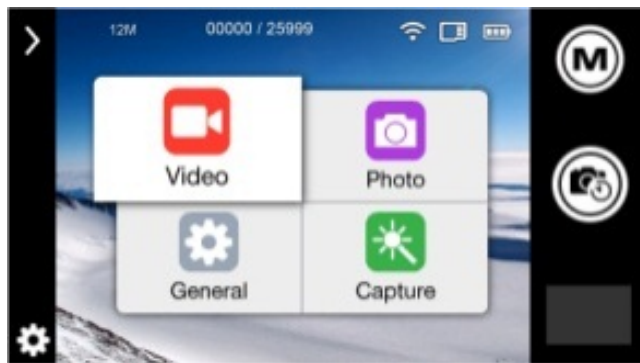





Figure 4-1 *Settings Screen*

Table 4-3 Camera SettingsButtons

Camera Settings	Button	Description
General		Adjusts general camera settings, e.g. Bootup Rec and Brightness .
Video		Adjusts Video Resolution , FPS (Frame Per Second), Looping , PIV (Picture in Video), Format or Angle (field of view).
Photo		Adjusts Photo Resolution , Burst , Time Lapse or Single .
Capture		Adjusts photo Rotate , Color , WB (White Balance), Sharpness , Meter or Exposure .

➤ **To enter the Settings menu**

Tap the **Settings** icon from the bottom left corner of the screen, or press the **Power/Mode** button to cycle through the list.







➤ **To exit the Settings menu**









Tap the **Settings** icon from the bottom left corner of the screen, or simply tap any place on screen.

4.3.1 General Settings

You can adjust the following general camera settings: **Volume**, **OSD** (On Screen Display), **LED Blink**, **LCD** (Liquid Cristal Display), **Brightness**, **Bootup Rec**(starts recording after powering up), **Time Stamp**, **System** (NTSC/PAL), **Auto Off**, **Language**, **Day/Time**, **Delete**, **Reset**, **Wi-Fi** and **Version**.

Table 4-4 *General Settings Buttons*

General Settings	Button	Options
Volume		OFF; 70%; 100% (Default).
OSD On Screen Display.		OFF; ON (Default).
LED Blink		OFF; ON (Default).
LCD Auto turns off the LCD.		1min; 3min; 5min; Never (Default).
Brightness		High (Default); Medium; Low.
Bootup Rec Starts recording when turning on your camera.		OFF (Default); ON.

General Settings	Button	Options
Time Stamp Stamps on the Files.		OFF (Default); Date; Time; Date/Time.
TV System		PAL; NTSC (Default).
Auto Off Auto turns off camera.		1min; 3min; 5min; OFF (Default).
Language		English (Default).
Date/Time		Yes; No (Default).
Delete Delete all files.		√ ; × (Default).
Reset Restore default settings.		√ ; × (Default).
Wi-Fi		OFF (Default); App; Fly Mode.
Version		Displays the current version.

NOTE: When you select **Delete** in general settings, the SD card will be formatted. Make sure to create a back-up copy of SD card.

When you select **TV system** to view a TV/HDTV, select NTSC

for North American televisions; for those outside of North America, select PAL in most cases.

➤ **To adjust the General Settings**

1. Tap the **Settings** icon from the bottom left corner of the screen, or press the **Power/Mode** button to cycle through the list.
2. Tap to select **General** from the **Settings** menu. Use the **Power/Mode** button to cycle through the list.
3. Tap to select or press the **Shutter/Select** button to select the desired option.
4. Tap **Back** to exit.

➤ **To Start Bootup Rec**





1. Tap the **Settings** icon from the bottom left corner of the screen, or press the **Power/Mode** button to cycle through the list.
2. Tap to select **General** from the **Settings** menu. Use the **Power/Mode** button to cycle through the list.
3. Tap to select or press the **Shutter/Select** button to select **Bootup Rec**.
4. Tap **Back** to exit.

NOTE: When you select **Bootup Recin** general settings, make sure the camera is in video mode before powering off.

4.3.2 Video Settings

You can adjust Video **Resolution**, **FPS**(Frames per Second),**Looping**, **PIV**(Picture in Video), **Format**and**Angle**according to the following table.

Table 4-5 Video Settings Buttons

Video Settings	Button	Options
Resolution		1080P (16:9) (Default) 960P (4:3); 720P (16:9); WVGA (16:9).
FPS Frame Per Second		24, 30, 48, 60 fps(NTSC Default) *PAL Default: 50 fps.
Looping Cyclic recording		OFF (Default); 1, 5, 15, 30 min/video.
PIV Picture in Video		OFF (Default); 5, 10, 30, 60 sec.
Format		MOV; MP4 (Default).

Video Settings	Button	Options
Angle Field of View		Wide (Default); Medium; Narrow.

➤ **To adjust the Video Settings**

1. Tap the **Settings** icon from the bottom left corner of the screen, or press the **Power/Mode** button to cycle through the list.
2. Select **Video** from the **Settings** menu.
3. Tap to select or press the **Shutter/Select** button to select the desired option.
4. Tap **Back** to exit.

NOTE: PIV (Picture in Video) captures pictures at various time intervals while recording.

4.3.3 Photo Settings

You can change the settings of **Photo Burst** and **Time Lapse** in the following photo settings of your X-Memo camera.

Table 4-6 *Photo Settings Buttons*





Photo Settings	Button	Options
Resolution		12M(Default); 7M; 5M.

Photo Settings	Button	Options
Time Lapse		0.5, 1, 2 sec 5 sec (Default), 10, 30, 60 sec.
Burst		3, 5, 8 photos/1 second 10 photos/1 second (Default).
Single		OFF (Default); 3, 5, 10 sec.

➤ **To adjust the Photo Settings**







You can adjust Photo **Resolution**, **Time Lapse**, **Burst** and **Single** in the same way as [4.3.2 video settings](#).

4.3.4 Capture Settings

The X-Memo allows a variety of advanced settings in **Capture Settings** menu.

Table 4-7 *Capture Settings Buttons*

Capture Settings	Button	Options
------------------	--------	---------

Capture Settings	Button	Options
Rotate		OFF (Default); ON; Auto.
Color		Auto (Default); Autel.
WB		Auto (Default); 300k; 5500k; 6500k.
Sharpness		High; Medium (Default); Low.
Meter		Center (Default); Average; Spot.
Exposure		-2.0; -1.5; -1.0; -0.5; 0 (Default) +0.5; +1.0; +1.5; +2.0.

➤ **To adjust the Capture Settings**

You can adjust the above capture settings in the same way as [4.3.2 Video settings.](#)

4.4 Playback

The X-Memo camera allows you to directly view the videos and photos on camera or connect it to a TV/HDTV.

➤ **To playback on X-Memo**

1. Press the **Power/Mode** button to cycle through the list, or tap the thumbnail at the right bottom corner of screen.
2. Tap to select the desired photos or videos, you can zoom in or zoom out the photos on touchscreen.
3. While viewing the selected files, tap the screen or press the **Power/Mode** button to display the menu. Select the square icon to display the thumbnail preview.
4. Tap **Back** to exit.

➤ **To playback on TV/HDTV**

1. Connect the camera to a TV/HDTV with a Micro HDMI Cable.
2. Turn on the camera.
3. Press the **Power/Mode** button to cycle through the list, or tap the thumbnail at the lower right corner of screen.
4. The X-Memo displays the thumbnail previews of all the files on your SD card. Use the **Power/Mode** button to cycle through thumbnails and then press the **Shutter/Select** button or simply tap to view the desired photos.
5. Press the **Power/Mode** button to select. Press the **Shutter/Select** button or simply tap the arrows to navigate through the files.

6. While viewing the selected file, tap the screen or press the **Power/Mode** button to display the menu, and then select to display the thumbnail preview.
7. Tap **Back** to exit.

4.5 Transferring files

➤ **To transfer photo and video files to a PC**

1. Plug the camera into a computer via the USB cable supplied.
2. Press the **Power/Mode** button to turn the camera ON.
3. Double click “**My Computer**” and select “**Removable Disk**”.
4. Double click “**Removable Disk**” icon.
5. Double click “**DCIM**” icon.
6. Double click “**100 media**” to view all the files on microSD card.
7. Copy files to your computer or other storage devices.

➤ **To transfer photo and video files to a Mac**

Follow the same steps as transferring files to a PC.

Chapter 5 X-Memo App Operations

5.1 Wi-Fi Connection

- **To turn on the Wi-Fi on camera**
 1. Turn on the camera.
 2. Long press the **Shutter/Select** button to enter the **Wi-Fi** settings menu.
 3. Tap to select “**App**” or “**Fly mode**”, then the top and front LED indicator lights will flash every second.
 4. Tap “**Back**” to exit.

5.2 X-memo App

- **To use the X-memo App on smartphone or tablet**
 1. Download the X-memo App from Google Play or Apple Store.
 2. Press the **Power/Mode** button to turn on the camera.
 3. Long press the **Shutter/Select** button to enter the **Wi-Fi** settings menu.
 4. Tap to select “**App**” option.
 5. Pair your smartphone or tablet with the “autel_camera” Wi-Fi network.
 6. Enter the default password “123456789”. You can customize the network name and password at **AP**

Setting. If you have already changed the password, enter the new password.

7. Tap the “**X-memo**” app on your smartphone or tablet. You can control the camera through the smartphone or tablet.
8. Tap “**Back**” to exit.

Chapter 6 Maintenance and Services

To ensure that the X-Memo performs at its optimum level, we advise that the product maintenance instructions covered in this section are read and followed.

6.1 Maintenance Instructions

The following shows how to maintain your camera, together with precautions to take.

- Use a soft cloth and alcohol or a mild window cleaner to clean the touch screen of the camera.
- Do not use any abrasive cleansers, detergent or chemicals on the camera.
- Keep the devices in dry conditions within normal operating temperatures.
- Dry your hands before using the devices. The touch screen of the camera may not work if the touch screen is moist, or if you tap the touch screen with wet hands.
- Do not store the devices in humid, dusty or dirty areas.
- Do not attempt to disassemble your devices.
- Avoid dropping the camera. If the camera is dropped, especially on a hard surface, the user shall take it to a service center for inspection.

Chapter 6 Maintenance and Services

- Use only authorized battery chargers and accessories. Any malfunction or damage caused by the use of unauthorized battery charger and accessories will void the limited product warranty.
- Ensure that the battery charger does not come in contact with conductive objects.

6.2 Troubleshooting Checklist

A. When you cannot turn on the camera:

- Make sure the battery is properly inserted in the camera.
- Make sure the battery has enough power to turn on the camera.

B. When the camera does not work properly:

- Check if your SD card is compatible with the X-Memo camera.
- Make sure your SD card has been formatted before inserting in the camera.

C. When you cannot transfer the files to PC:

- Make sure the connection between the X-Memo camera and your PC is established.
- Check if the USB cable is usable.
- Make sure your SD card is properly inserted into the SD card slot.
- Make sure the files in SD card can be recognized by your PC.

D. When you are unable to charge the camera:

- Make sure the battery is properly installed in the camera.

- Your device may have not been connected to the charger properly. Check the connector.
- Your charger may be malfunctioning.

E. When Wi-Fi network cannot be found in your mobile device:

- Make sure you have turned on the AP mode or Station mode.
- Check your smart device.

NOTE: If your problems persist, please contact Autel's technical support personnel or your local selling agent.

6.3 About Battery Usage

Your camera is powered by a non-built-in Lithium-ion Polymer battery. This means that you shall insert the battery in camera for first time use.



DANGER: Incorrect operations or tampering with the battery pack may cause an explosion.

- Do not use a damaged battery charger.
- Do not disassemble or crush, bend or deform, puncture or shred the battery.
- Do not modify, remanufacture or attempt to insert foreign objects into the battery, or expose it to fire, explosion or other hazards.
- Make sure to only use the USB cable that comes together in the package. If you use the other USB cable, you might incur malfunction or failure of the device.
- Only use the charging device that has been qualified with the device per this standard. Use of an unqualified battery or charger may present risks of fire, explosion, leakage, or other hazards.
- The battery recharging time varies depending on the remaining battery capacity.

Chapter 6 Maintenance and Services

- Battery life inevitably shortens over time.
- Since over charging may shorten battery life, remove the camera from its charger once it is fully charged. Unplug the charger once charging is complete.
- Promptly dispose of used batteries in accordance with local regulations.

Chapter 7

Compliance Information

FCC ID WQ8301SDCHD1

IC 10826A-SDCHD1

Chapter 8 Warranty**12-Month Limited Warranty**

Autel Intelligent Technology Corp., Ltd. (the Company) warrants to the original retail purchaser of this X-Memo action camera, that should this product or any part thereof during normal consumer usage and conditions be proven defective in material or workmanship that results in product failure within twelve (12) months period from the date of delivery, such defect(s) will be repaired, or replaced (with new or rebuilt parts) with Proof of Purchase, at the Company's option, without charge for parts or labor directly related to the defect(s).

The Company shall not be liable for any incidental or consequential damages arising from the use, misuse, or mounting of the device. Some states do not allow limitation on how long an implied warranty lasts, so the above limitations may not apply to you.

This warranty does not apply to:

- a) Products subjected to abnormal use or conditions, accident, mishandling, neglect, unauthorized alteration, misuse, improper installation or repair or improper storage;
- b) Products whose mechanical serial number or electronic

serial number has been removed, altered or defaced;

c) Damage from exposure to excessive temperatures or extreme environmental conditions;

d) Damage resulting from connection to, or use of any accessory or other product not approved or authorized by the Company;

e) Defects in appearance, cosmetic, decorative or structural items such as framing and non-operative parts.

f) Products damaged from external causes such as fire, dirt, sand, battery leakage, blown fuse, theft or improper usage of any electrical source.

IMPORTANT: All contents of the product may be deleted during the process of repair. You should create a back-up copy of any contents of your product before delivering the product for warranty service.

Warning:

Any Changes or modifications not expressly approved by the party responsible for compliance could void the user's authority to operate the equipment.

This device complies with part 15 of the FCC Rules. Operation is subject to the following two conditions: (1) This device may not cause harmful interference, and (2) this device must accept any interference received, including interference that may cause undesired operation.

Note: This equipment has been tested and found to comply with the limits for a Class B digital device, pursuant to part 15 of the FCC Rules. These limits are designed to provide reasonable protection against harmful interference in a residential installation. This equipment generates, uses and can radiate radio frequency energy and, if not installed and used in accordance with the instructions, may cause harmful interference to radio communications. However, there is no guarantee that interference will not occur in a particular installation. If this equipment does cause harmful interference to radio or television reception, which can be determined by turning the equipment off and on, the user is encouraged to try to correct the interference by one or more of the following measures:

—Reorient or relocate the receiving antenna.

—Increase the separation between the equipment and receiver.

—Connect the equipment into an outlet on a circuit different from that to which the receiver is connected.

—Consult the dealer or an experienced radio/TV technician for help.

For body worn operation, this model cameral has been tested and meets the FCC RF exposure guidelines when used with an accessory designated for this product or when used with an accessory that Contains no metal and that positions the cameral a minimum of 0 CM from the body and head.

Non-compliance with the above restrictions may result in violation of RF exposure guidelines.