



WIRELESS AUDIO/VIDEO SENDER
with IR Extender Feature



RadioShack

OWNER'S MANUAL

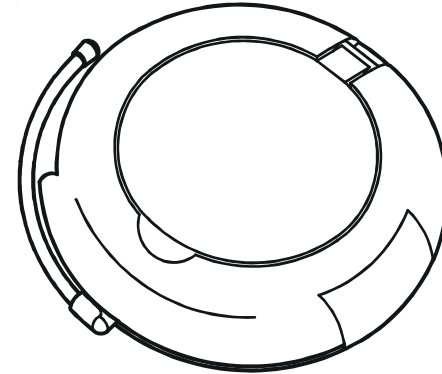

SENDER 15-2572T

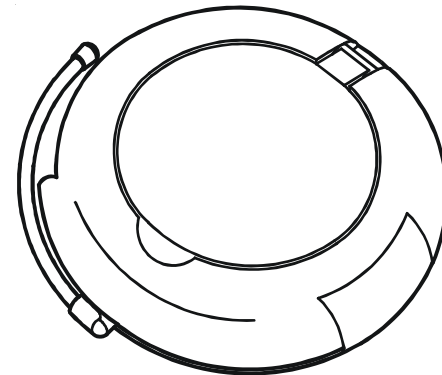

SENDER 15-2572T

CAT. No. 15-2572





FCC CAUTION

THIS DEVICE COMPLIES WITH PART 15 OF THE FCC RULES. OPERATION IS SUBJECT TO THE FOLLOWING TWO CONDITIONS:

- (1) THIS DEVICE MAY NOT CAUSE HARMFUL INTERFERENCE, AND
- (2) THIS DEVICE MUST ACCEPT ANY INTERFERENCE RECEIVED, INCLUDING INTERFERENCE THAT MAY CAUSE UNDESIREED OPERATION.

NOTE: Modifications to this product will void the user's authority to operate this equipment.



INTRODUCTION

Your Wireless Audio/Video Sender system consists of a Sender unit which you connect to your satellite receiver, DVD player, etc., and a Receiver unit that you connect to a TV anywhere in your home. The Audio/Video Sender converts the A/V signal from your A/V product into a 2.4 GHz wireless Radio Frequency (RF) signal and transmits it (even through walls) to the Audio/Video Receiver unit. The Audio/Video Receiver converts the signal back to an A/V signal and passes it through a cable to your TV's COAX input, or A/V input jacks.

The Audio/Video Sender system also includes an IR Extender feature. This lets you remotely control the A/V product that the Sender is connected to, from the location where the Receiver is located. For example, you can control a DVD Player in your living room, while watching it on a TV in your bedroom.

There are just a few simple steps to follow to hook up your Audio/Video Sender system to a satellite receiver, VCR, DVD Player, or Cable Box.

CONTENTS

- INTRODUCTION 3
- CONTROLS AND CONNECTIONS 4
 - SENDER 4
 - RECEIVER 5
- CONNECTING UP 6
 - HOOKING UP THE SENDER 6
 - HOOKING UP THE RECEIVER 8
- FINE TUNING YOUR SYSTEM 10
- IR EXTENDER FEATURE 11



CONTROLS AND CONNECTIONS

Audio/Video Sender

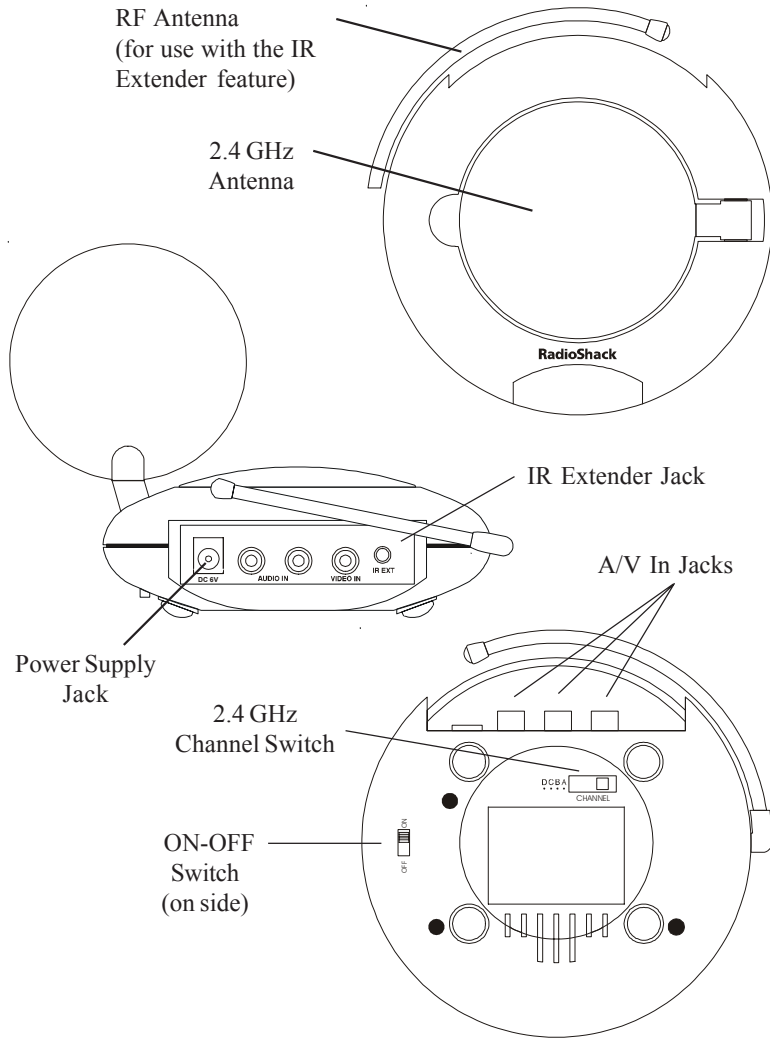

4

Audio/Video Receiver

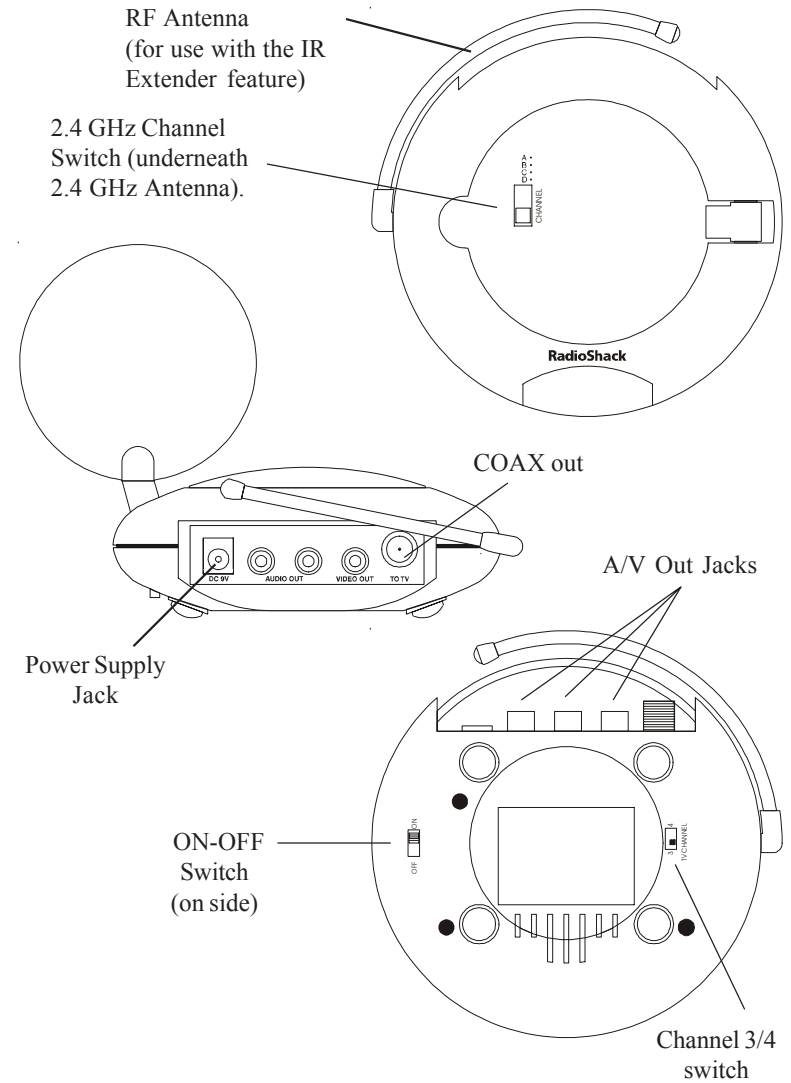

5

CONNECTING UP

Hooking up the Audio/Video Sender

1. Connect one set of Audio/Video cables to the VIDEO and AUDIO jacks of your Audio/Video Sender. Take care to match the colors of the plugs on the cable with the jacks on the Audio/Video Sender.
2. Connect the other end of the cable to the Audio/Video OUT jacks on your TV. Take care to match the colors of the plugs on the cable with the jacks on the TV. If the jacks on the TV are colored differently, connect the yellow plug to the jack labelled VIDEO, the red plug to the jack labelled AUDIO RIGHT and the white plug to the jack labeled AUDIO LEFT. See diagram A below.

Note: If your TV does not include Audio/Video OUT jacks, you will need to remake the connections as shown in diagram B) using the TV antenna (coaxial) connections to link up a Satellite Receiver (DBS), or Cable Box, or VCR, or DVD Player to your TV.

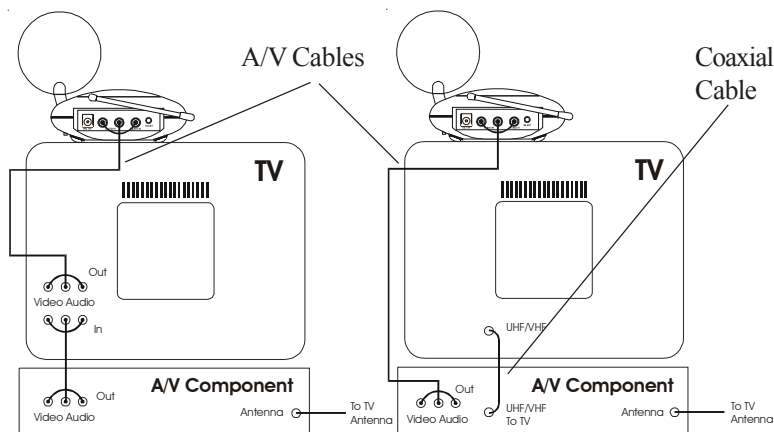

A) Connections for a TV with A/V OUT jacks.

B) Connections for a TV without A/V OUT jacks.



3. Plug the Audio/Video Sender's Power Supply into a convenient 120 volt wall outlet and plug its jack into the Audio/Video Sender.
4. Position the Audio/Video Sender in a convenient location such as on top of your TV and orient the antenna so that the flat side points in the direction of the room where you will be installing the Receiver.

If you have several A/V components:

If you have two or more A/V components (e.g. Satellite Receiver (DBS), VCR, Cable Box, DVD Player, etc.) that you want to watch in another room, they will probably already be hooked up to the local TV in series (see the diagram to the right). To connect the Audio/Video Sender you just need to identify the last component in the chain and connect its LINE OUT jacks to the Audio/Video Sender's A/V IN jacks.

If the last component in the chain does not have spare LINE OUT jacks, reconnect the local TV to the last component in the chain using a coaxial cable to connect to the VHF/UHF jack, then use the A/V connections for the Audio/Video Sender.

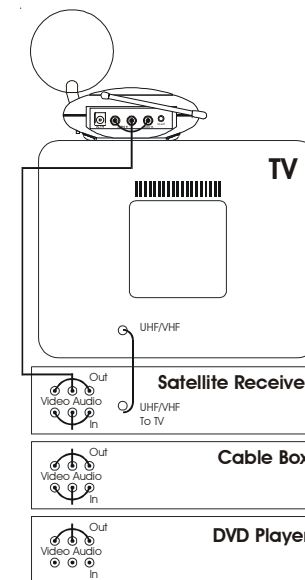



Hooking up the Audio/Video Receiver

1. Connect a set of Audio/Video cables to the A/V OUT jacks of your Audio/Video Receiver. Connect the other end to your TV.

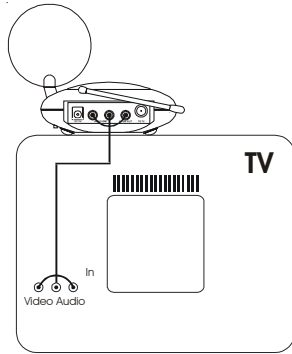

2. Plug the Audio/Video Receiver's Power Supply into a 120 volt wall outlet and plug its jack into the Audio/Video Receiver.
3. Position the Audio/Video Receiver in a convenient location such as on top of your TV and orient the antenna so that the flat side points in the direction of the room where you set up the Audio/Video Sender.

If your second TV is already hooked up to a Satellite Receiver or other A/V device:

If your Satellite Receiver or other A/V component is connected to the TV using A/V cables, you can connect the Audio/Video Receiver to the free LINE IN jacks on the component. If there are no LINE IN jacks, you will need to use a TV antenna splitter as described on the next page.

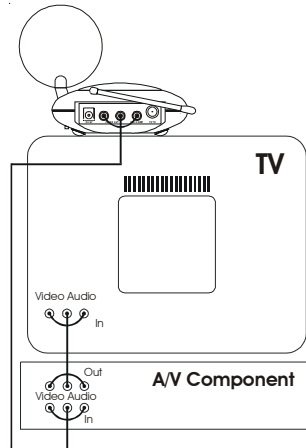

If your TV does not have A/V connectors:

You can use the supplied coaxial cable to connect the TV OUT COAX socket on the Audio/Video Receiver to the Antenna input on your TV. If you already have an antenna connected to your TV, you will need to use a TV antenna splitter as shown below.

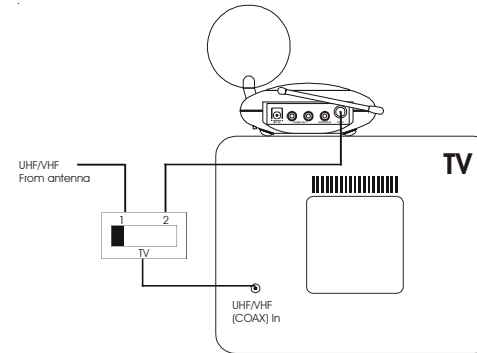

Set your TV and the TV Channel switch on the Audio/Video Receiver (on the bottom of the unit) to the same channel (3 or 4).



FINE TUNING YOUR SYSTEM

The Wireless Audio/Video Sender usually works best with the flat faces of the antennas on the Sender and Receiver units facing each other, see diagram below. Sometimes, however, reflections and other effects in your home may affect the signal so that some adjustment of either the Sender or Receiver antenna might be necessary to get the best signal.

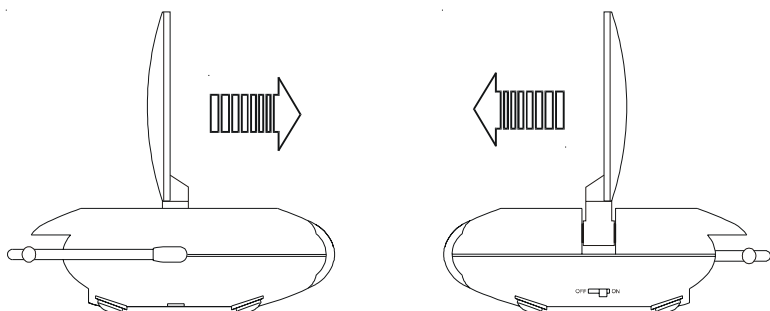

If you are not getting any sound or picture at all from the Receiver:

- Check that the CHANNEL slide switch (labeled A, B, C, D) on both units is set to the same letter. The switch is on the bottom of the Sender unit and it's under the flip-up antenna on the Receiver unit.
- Check that both the Sender's and Receiver's power supplies are plugged in.
- Check that the ON/OFF switch on the Sender and Receiver are ON.

If the video or sound is poor, or there is interference:

Try changing the channel on both units. Do this by adjusting the CHANNEL slide switch on each unit to any position from A to D. Make sure both units are set to the same letter.

USING THE IR EXTENDER FEATURE

The IR extender feature lets you use your original remote control to control the A/V product that the Audio/Video **Sender** is connected to. E.G., if the Sender is connected to a DVD Player, or VCR in your living room, and the Audio/Video Receiver is connected to a TV in your bedroom; you can control the DVD Player or VCR while watching the picture from it on the TV in your bedroom. You do this by pointing your remote control at the Audio/Video Receiver that's connected to your bedroom TV. It receives the IR commands from your remote and converts them to wireless Radio Frequency (RF) commands, and sends them to the Audio/Video **Sender**. You plug the IR extender cable into the jack on the back of the Audio/Video **Sender** and attach the IR emitters to the front of the DVD Player, or VCR, etc. that you want to control.

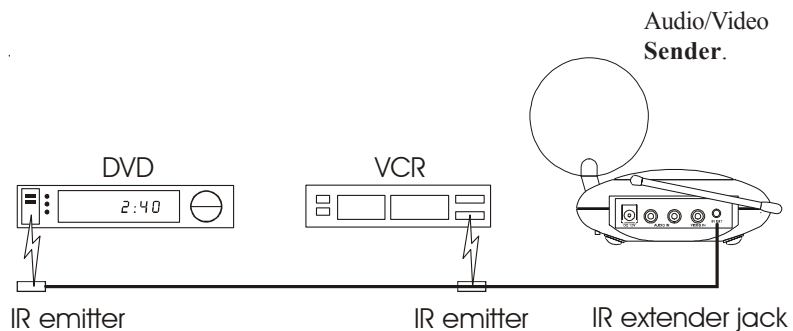

1. Plug the IR extender jack on the IR emitter cord into the IR EXT. socket located on the back of the Audio/Video **Sender**.
2. Place the emitter cord in front of the two devices you want to control (e.g., DVD and VCR).
3. Make sure that the two IR emitters are attached close to the IR sensors on the devices you want to control.

The IR emitter cord lets you control up to two IR devices.



LIMITED NINETY-DAY WARRANTY

This product is warranted by RadioShack against manufacturing defects in material and workmanship under normal use for ninety (90) days from the date of purchase from RadioShack company-owned stores and authorized RadioShack franchisees and dealers.

EXCEPT AS PROVIDED HEREIN, RadioShack MAKES NO EXPRESS WARRANTIES AND ANY IMPLIED WARRANTIES, INCLUDING THOSE OF MERCHANTABILITY AND FITNESS FOR A PARTICULAR PURPOSE, ARE LIMITED IN DURATION TO THE DURATION OF THE WRITTEN LIMITED WARRANTIES CONTAINED HEREIN. EXCEPT AS PROVIDED HEREIN, RadioShack SHALL HAVE NO LIABILITY OR RESPONSIBILITY TO CUSTOMER OR ANY OTHER PERSON OR ENTITY WITH RESPECT TO ANY LIABILITY, LOSS OR DAMAGE CAUSED DIRECTLY OR INDIRECTLY BY USE OR PERFORMANCE OF THE PRODUCT OR ARISING OUT OF ANY BREACH OF THIS WARRANTY, INCLUDING, BUT NOT LIMITED TO, ANY DAMAGES RESULTING FROM INCONVENIENCE, LOSS OF TIME, DATA, PROPERTY, REVENUE, OR PROFIT OR ANY INDIRECT, SPECIAL, INCIDENTAL, OR CONSEQUENTIAL DAMAGES, EVEN IF RadioShack HAS BEEN ADVISED OF THE POSSIBILITY OF SUCH DAMAGES.

Some states do not allow limitations on how long an implied warranty lasts or the exclusion or limitation of incidental or consequential damages, so the above limitations or exclusions may not apply to you. In the event of a product defect during the warranty period, take the product and the RadioShack sales receipt as proof of purchase date to any RadioShack store. RadioShack will, at its option, unless otherwise provided by law: (a) correct the defect by product repair without charge for parts and labor; (b) replace the product with one of the same or similar design; or (c) refund the purchase price. All replaced parts and products, and products on which a refund is made, become the property of RadioShack. New or reconditioned parts and products may be used in the performance of warranty service. Repaired or replaced parts and products are warranted for the remainder of the original warranty period. You will be charged for repair or replacement of the product made after the expiration of the warranty period.

This warranty does not cover: (a) damage or failure caused by or attributable to acts of God, abuse, accident, misuse, improper or abnormal usage, failure to follow instructions, improper installation or maintenance, alteration, lightning or other incidence of excess voltage or current; (b) any repairs other than those provided by a RadioShack Authorized Service Facility; (c) consumables such as fuses or batteries; (d) cosmetic damage; (e) transportation, shipping or insurance costs; or (f) costs of product removal, installation, setup service adjustment or reinstallation.

This warranty gives you specific legal rights, and you may also have other rights which vary from state to state.

RadioShack Customer Relations, 200 Taylor Street, 6th Floor, Fort Worth, TX 76102

Custom Manufactured in China for RadioShack, Ft. Worth, TX 76102.

15-2572-08/06

