

PA700V1 - Overhead Door Operator

Instruction Manual (Instruction d'Installation)

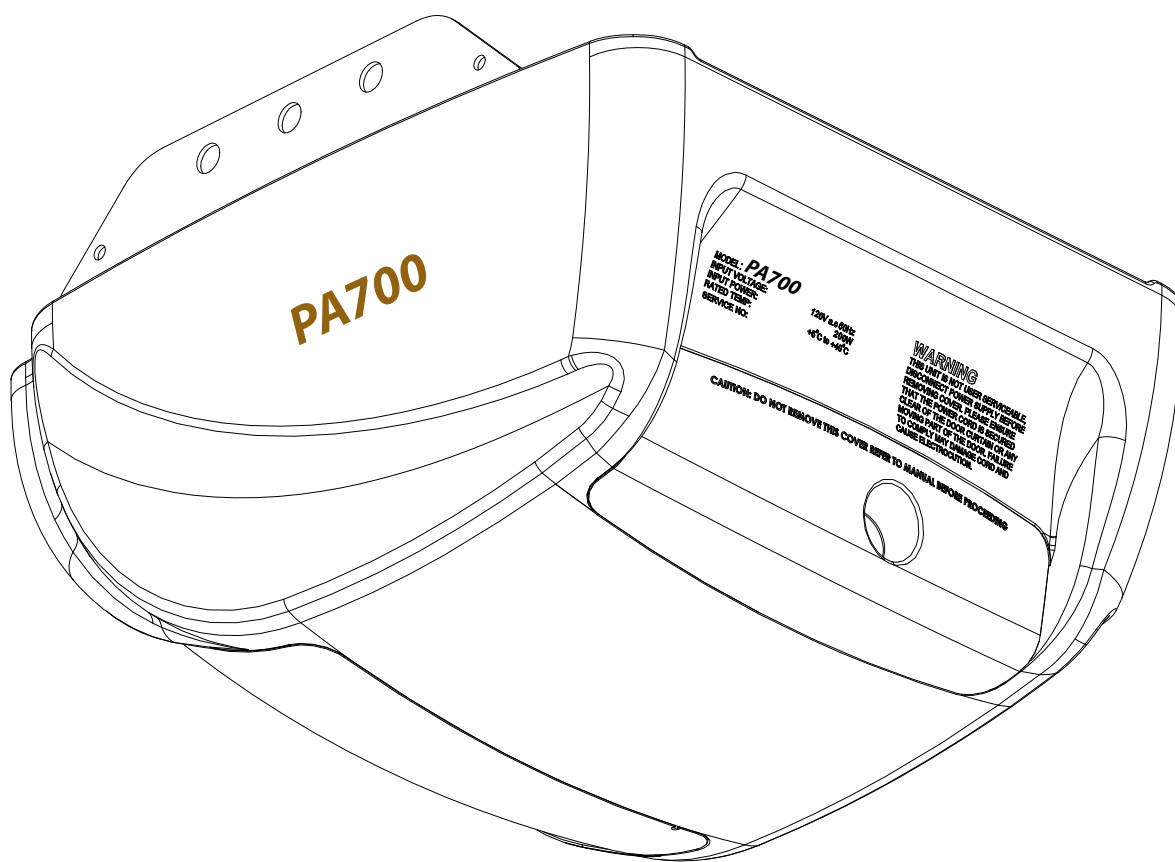

FOR RESIDENTIAL USE ONLY



WARNING: It is vital for the safety of persons to follow all instructions. Failure to comply with the installation instructions and the safety warnings may result in serious personal injury and/or property and remote control opener damage. Please save these instructions for future reference.



AVERTISSEMENT: pour la sécurité des usagers, il est essentiel de suivre toutes les instructions. Le non-respect des instructions d'installation et des avertissements de sécurité peut causer de graves blessures et/ou endommager l'appareil et la télécommande. Veuillez conserver ces instructions pour future référence.



To reduce the risk of electric shock, this equipment has a grounding type plug that has a third (grounding) pin. This plug will only fit into a grounding type outlet. If the plug does not fit into the outlet, contact a qualified electrician to install the proper outlet. Do not change the plug in any way.



Pour réduire les risques de choc électrique, cet appareil est équipé d'une fiche avec mise à la terre comportant une troisième broche (broche de terre). Cette fiche ne peut être branchée que dans une prise avec mise à la terre. S'il n'est pas possible de la brancher dans la prise, faire poser une prise appropriée par un électricien qualifié. Ne pas modifier la fiche.

CONTENTS

PA700V1 Overhead Door Operator

Safety Rules	5
Default Settings & Specifications	6
About Your Operator	7
Operating Controls	8
Kit Contents	10
Installation	
Single piece C-Rail Assembly	11
Mounting Operator for Track Type Door	12
Mounting Door Bracket & Arms	13
Safety Beam Installation	14
Programming the Operator	15
Via Control Panel	15
Safety Obstruction Force	
Testing Safety Obstruction Force	16
Setting Safety Obstruction Force	17
Coding Transmitters	
For Door Operation	18
For Courtesy Light Operation	18
For Vacation Mode	19
For Auxiliary Output	19
For Pet (Pedestrian) Mode	20
Deleting All Transmitter Codes	20
Mounting Wall Transmitter (optional)	20
Accessories	
Terminal Block	21
Remote Aerial	21
Auxiliary / Key Switch	21

CONTENTS

PA700V1 Overhead Door Operator

How To Use Your Operator

Transmitter	22
Removing Battery from Transmitter	23
Manual Door Operation	23
Power Failure	23
Safety Beam	24
Courtesy Light	24
Auxiliary Output	24
Vacation Mode	24
Setting The Pet Mode Position	24

Maintenance **25**

Troubleshooting Guide **26**

Parameters **27**

Spare Parts **28**

Warranty **30**

Optional Accessories **32**

Safety Rules

(Les règles de la sécurité)



















Please read these important safety rules



These safety alert symbols indicate a personal safety or property damage instruction exists. **READ THESE INSTRUCTIONS CAREFULLY.**



This automatic garage door opener is designed and tested to offer safe service provided it is installed and operated in strict accordance with the following safety rules. Failure to comply with the installation instructions and the safety warnings may result in death, serious personal injury and/or property damage.

-  **CAUTION:** If your garage has no pedestrian entrance door, an emergency access device should be installed. This accessory allows manual operation of the garage door from outside in case of power failure.
-  Position the Garage Door Operator so that the power plug is accessible when inserted into the power outlet.
-  This operator should be installed in accordance with relevant US and Canada Standards.
-  Do not allow children to play with door controls.
-  Keep transmitters away from children.
-  Watch the moving door and keep people away until the door is completely opened or closed.
-  Activate the operator only when the garage door is in full view, free of obstructions and with the operator properly adjusted.
-  Keep the garage door balanced. Sticking or binding doors must be repaired. Garage doors, door springs, brackets and their hardware are under extreme tension and can cause serious personal injury. Do not attempt any garage door adjustment. Do not use if repair or adjustment is needed. Call for professional garage door service.
-  Install the optional wall transmitter in a location where the garage door is visible, but out of the reach of children at a height of at least 5 feet (1.53m).
-  Disconnect electric power to the garage door operator before removing covers.
-  Door must have Safety Beams fitted.
-  Do not wear rings, watches or loose clothing while installing or servicing a garage door operator.
-  This operator is not suitable for commercial, industrial or common entry applications.
-  To avoid serious personal injury from entanglement, remove all unnecessary ropes or chains and disable any equipment such as locks which are not needed for powered operation.
-  Installation and wiring must be in compliance with your local building and electrical codes. Connect the power cord only to properly earthed mains. If an extension lead must be used, make sure it is a 3-core lead and approved to 7 Amp capacity.
-  To reduce the risk of electric shock, this equipment has a earthing type plug that has a third (earthing) pin. This plug will only fit into a earthing type outlet. If the plug does not fit into outlet, contact a qualified electrician to install the proper outlet. Do not change the plug in any way.
-  If the power cord is damaged, it must be replaced by the manufacturer, its service agent or a similarly qualified person in order to avoid a hazard.
-  This opener is a plug in domestic appliance and is designed for indoor use only. It must be installed in a dry position that is protected from the weather.
-  The opener is not intended for use by young children or infirm persons without supervision.



WARNING! It is vital for the safety of persons to follow all instructions. Save these instructions.

Default Settings & Specifications

Factory default settings

	Default	Step	Minimum	Maximum
Courtesy light time	3 minutes	Not adjustable	-----	-----
Obstruction force margin	0.7A	0.1A	0	2A

Technical specifications

Input Voltage	120Vac / 60Hz
Input power (max)	150 Watts
Standby power, less than	1.8 Watts
Transformer secondary output Voltage	24Vac
Motor type	24Vdc geared motor with permanent magnet
Shuttle travel distance in the C-Rail	8.858ft (2.7m) approximately (standard)*
Maximum shuttle travel distance in the C-Rail	12.3ft (3.75m) (with one extension)*
Maximum door area	140sq.ft (13.5m ²)
Maximum door hanging weight	297.36lbs (135kg)
Minimum headroom	1" (25.4mm)
Receiver type	UHF Multifrequency FM-Receiver
Receiver code storage capacity	8 X 4 button Transmitter Codes
Transmitter frequencies	433.47MHz; 433.92MHz; 434.37MHz
Coding type	TrioCode™
Number of code combinations	Over 4.29 billion random codes
Code generation	Nonlinear encryption algorithm
Transmitter battery	CR2032 (3 Volts)
Courtesy light	LED's Module
Controller fuse	10A (slow blow)

*The actual travel distance of the door depends on configuration of the connecting arms.

NOTE: Intermittent operations may occur in areas which experience very strong winds. The strong wind puts extra pressure on the door and tracks which may in turn intermittently trigger the safety obstruction detection system.

About Your Operator

Thank you for choosing a PA700 automatic garage door operator.

The technically advanced construction of this operator ensures you enjoy the following benefits:

Warranty

xxx (x) years / xxxx cycles full parts and labour warranty on motor, electronics and mechanical components of the opener when installed by a garage door professional (conditions such as annual garage door servicing apply).

TrioCode™ Frequency Hopping Technology

Every time a transmitter is used, it simultaneously sends a signal over three different frequencies, reducing the chance of interference from other radio frequency sources.

Code Hopping Technology

Every time a transmitter is used a new security code is generated from over 4.29 billion possible code combinations. This greatly enhances the security of the system and makes "code grabbing" a thing of the past!

Multi-Channel Transmitter

Multi-channel transmitters allow you to operate other devices such as an adjoining garage door or automated gate from the same handy unit.

Warranty Expired Indicator

The opener will indicate that the number of cycles covered by the warranty has been reached by flashing the courtesy light 10 times after each operation. This flashing will continue for 20 cycles unless it is reset by pressing the SET button while the courtesy light is flashing.

S-ALPS (Semi Automatic Limits Positioning System)

The S-ALPS system does away with manual adjustment of the door's limits position using mechanical parts, such as cams and microswitches.

Safety Reversing System

The automatic safety reverse system significantly reduces the risk of death or serious injury if trapped by a closing door. The safety reverse force can be adjusted for environmental conditions such as windy areas.

Safety Beam Protection

The Safety Beam is the infrared (IR) invisible light beam system which shall protect the doorway. The door stops and reverse to the full position if anything passes through the beam.

Courtesy Light

The courtesy light automatically switches on for approximately three (3) minutes when operating the door. This can also be programmed to turn on and off from a transmitter.

Memory Retention

In case of a power failure, the opener does not lose the transmitter codes or limit settings.

Soft Start/Soft Stop

The opener eases into and out of each cycle making for smoother and quieter operation, as well as reducing wear and tear on the door and opener.

Manual Release

The manual release handle allows the door to be operated by hand in the event of a power failure.

Self Locking

There is no need to manually lock your garage door, as the operator 'positively' locks the door when closed.

Periodic Maintenance Indicator

The SERVICE LED will illuminate to indicate that periodic maintenance is required. Contact your garage door professional for service.

Service Fault Indicator

Flashing LEDs on the control panel easily identify operational problems or service requirements.

Dynamic Door Profiling

Changing door characteristics are automatically compensated for and "learnt" with each operation of the door.

External Aerial

An external aerial can be connected for sites where radio reception is a problem.

Vacation Mode

A transmitter can be programmed to disable the garage door opener radio receiver. This is ideal if the door is to be left idle for prolonged periods.

Pet (Pedestrian) Mode

A transmitter can be programmed to open the door partially to allow pets access to the garage. The door opening height is adjustable via a handheld programmer.

Auxiliary Output

You can program a spare button on your transmitter to operate this output, which can control items that use a momentary close switching mechanism.

Operating Controls

- 01. Terminal Block (J2):**
 - V+** (+35V/+24V) is used to power Accessories such as external receiver (200mA max)
 - SB-1** (mandatory) input is used to connect to **Safety Beam**
 - 0V** is a 0 volt connection for **Safety Beam**
 - SB-2** input is used to connect to **Safety Beam**
 - 0V** is a 0 volt connection for **Safety Beam**
 - AUX/OSC** This output has two chosen functions:
 - AUX** allows the operator to operate other devices such as an alarm system.
 - OSC** is used for the connection of a wired switch (momentary contact). This switch can then be used to open, stop or close the door. Install the wall switch in a location where the switch is out of reach of children and the garage door is visible.
- 02. CODING LED (Red)** light flashes when a code is being stored or when a transmitter button is pressed.
- 03. DOOR CODE** button is used for storing or erasing transmitter buttons for door operation
- 04. SERVICE LED (Yellow)** indicates when the opener requires service or repairs.
- 05. SET** button (Orange) is used during the installation phase together with the Open and MINUS (-) buttons to set the door limit positions. The Set button is also used to re-initialize the Opener.
- 06. OPERATE** button (Yellow) is used during installation to test the open, stop and close cycles for the opener. The opener has to be initialised by the SET button to make the OPERATE button operable.
- 07. FORCE MARGIN SET** button: The obstruction force margin is set automatically during installation. The margin can be adjusted manually using the Force Margin Set button (White). Holding the Force Margin Set button and pressing PLUS (+) or MINUS (-) buttons will increase or decrease the amount of force. The Force Margin Set should only be used if environmental factors (wind, etc.) affect the operation of the door.
- 08. OPEN LIMIT LED (Green)** the LED is very helpful during installation. It illuminates and flashes when the door is opening and remains steady on when the open limit position has been reached.
- 09. PLUS (+)** button (Green) is used during installation to help set the open limit position. Pressing and holding this button will move the door in the open direction, releasing stops the door.
NOTE: The safety obstruction detection is inoperable when the PLUS (+) button is used to move door.
- 10. CLOSE LIMIT LED (Red)** the LED is very helpful during installation. It illuminates and flashes when the door is closing and remains steady on when the close limit position has been reached.
- 11. MINUS (-)** button (Red) is used during installation to help set the close limit position. Pressing and holding this button will move the door in the close direction. Movement stops when the button is released.
NOTE: The safety obstruction detection is inoperable when the CLOSE button is used to move door.
- 12. DATUM ADJUST SCREW** is used during limits set up to indicate the mid point of the door's travel.
- 13. 10A FUSE** (Slow Blow)
- 14. PROG INPUT** is used to connect the handheld "PG-3" Programmer for editing control and receiver functions, accessing diagnostic tools, and activating special features and operating modes.
- 15. JP1 SOLAR CONNECTOR** the shunt must be fitted for solar operation.
- 16. COURTESY LIGHT** The LEDs Module is used for the courtesy light.

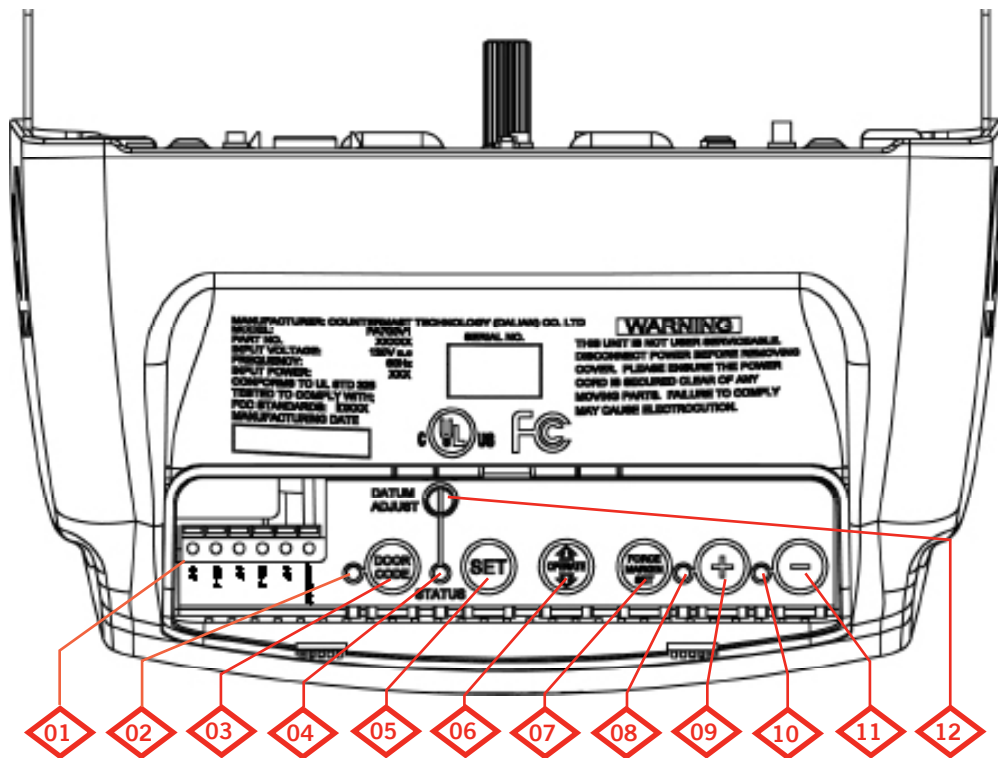

Fig. 01

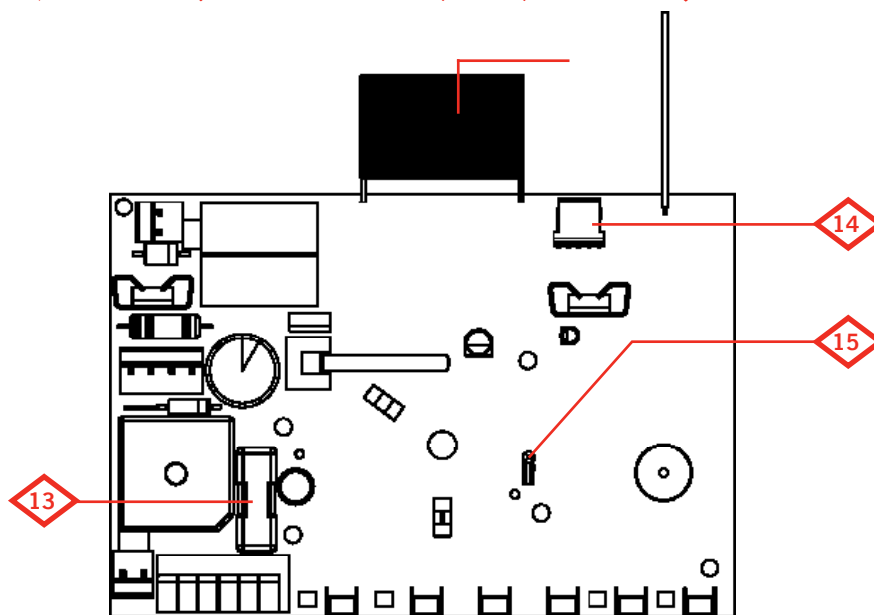
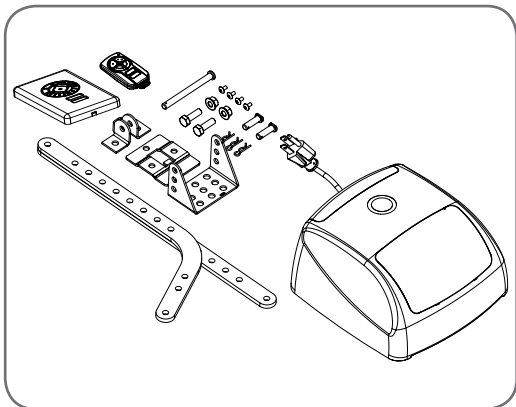

Fig. 02

Kit Contents

Fig. 03



PA700 Kit contains (Fig. 03)

- 1 x PA700 powerhead drive unit;
- 1 x Transmitters set
(Set includes PTX-5 (hand held remote control) and WTX-4 (wall mounted remote control) transmitters with batteries);
- 2 x Door attachment arms;
- 1 x Accessory and hardware pack;
- 1 x Installation Manual.

plus

Fig.04

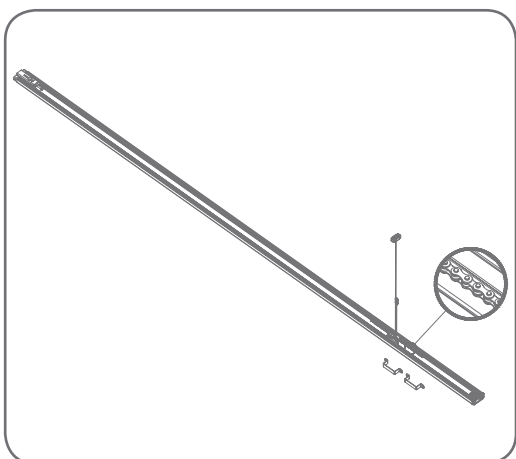

Single Piece C-Rail with Preassembled Chain (Belt)

NOTE: Chain in one piece rail has been tensioned by the factory. Do not adjust the tension of the chain.

IMPORTANT NOTE: If a modification to the length of the track is required, the adjustment must be made from the powerhead end only.

Installation



Where possible, install the door opener 7 feet or more above the floor.

C-Rail Attachment

Step 1 - Attach C-Rail to Powerhead

Locate and insert the powerhead's shaft into the C-Rail's sprocket as shown in **Fig.05**.

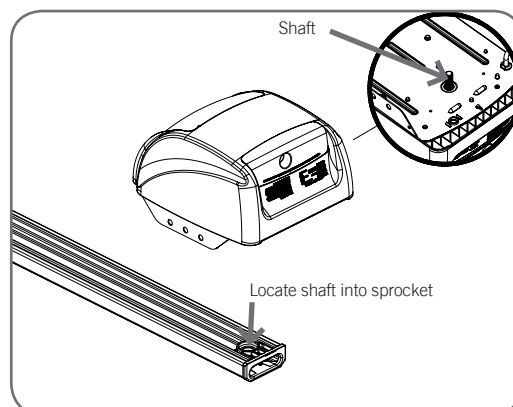

Fig. 05

Step 2 - Secure C-Rail to Powerhead

Fix the two track brackets as shown in **Fig.06**. Fix with the four screws supplied in the accessory pack.

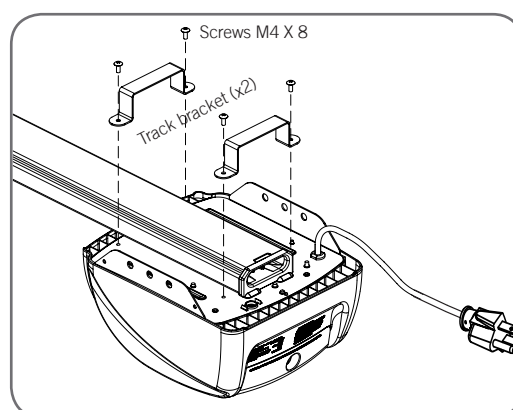

Fig.06

Mounting Operator for Track Type Door

Fig.7

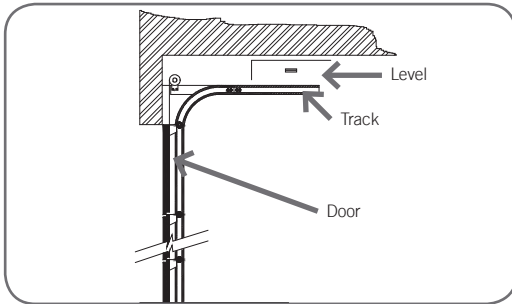

Fig.8

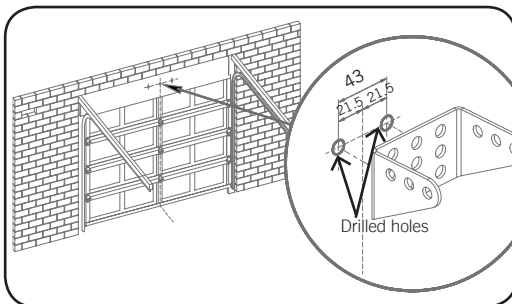

Fig.9

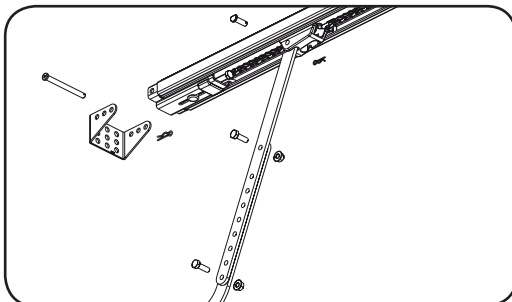
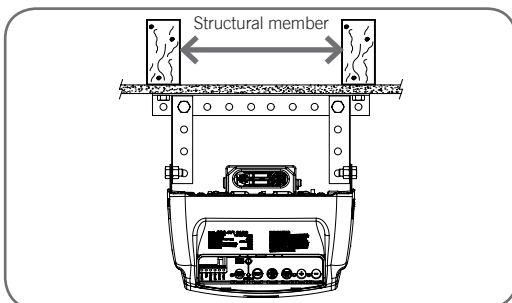

Fig.10



Step 3 - Determine Bracket Position

- Open the door and find the highest point of travel of the top door panel.
- Using a level, transfer this height to the wall above the door (Fig.7) and mark a line 2.36" (60mm) above it.
- Determine the centre point on the wall above and on top of the door. Then draw two lines extending 21.5mm from each side of the centre point. (Fig.8)

Step 4 - Mounting the Wall Bracket

- Centre the bracket over the intersection of these two lines. Mark centres for at least two holes (Fig.8).
 - Ensure a solid mounting point is behind these holes.
- Drill holes into the wall with an appropriate sized bit.
- Secure bracket to the wall using:
 - IF CONCRETE OR BRICK - 8mm or 5/6 loxins or dynabolts.
 - IF TIMBER - wood screw #20 or equivalent (minimum 50mm long).



WARNING: Make sure concrete, brick wall or timber lintels are solid and sound so as to form a secure mounting platform.

Step 5 - Attach the C-Rail to the Wall Bracket

- Attach the C-Rail assembly to the wall bracket with the 90mm long clevis pin and secure with the supplied snap pin (Fig.9).
- Leave the powerhead in its packing box for protection during installation.

Step 6 - Securing the Powerhead to the Ceiling

- Raise the powerhead from the packing box and support it in the horizontal position with a step ladder.
- Open the garage door. Rest the opener on the open door and use a scrap piece of wood to bring it to horizontal level.
- Line up the track perpendicular to the wall.
- Secure the perforated angle (not supplied) to the ceiling above where the powerhead's mounting holes will be once fully installed. A representative mounting is shown (Fig.10).
- Connect the powerhead to the ceiling mounted perforated angle with M8x20mm screws and nuts. Strips should not extend more than 0.71" (18mm) below the centre of the powerhead mounting holes (Fig.10).



WARNING: The opener must be securely fastened to structural supports, otherwise opener failure may ensue causing serious personal injury and/or property damage.

Mounting Door Bracket and Arms

Step 7 - Alternative Mounting Option

The operator can be fastened to the roof by driving a bolt through the C-Rail into a structural timber support. The bolt head's height must not exceed 6mm (Fig.11).

Step 8 - Mounting Door Bracket

The door bracket comes in two parts. The bottom plate with two mounting holes is used on its own for one piece doors. For sectional doors, the top plate is placed over the bottom plate and is fixed with four (4) screws (Fig.12).

- Mount the door bracket, or bracket assembly, on the door's centre line one-third down the top panel (Fig. 12) using M6 or equivalent screws (not supplied),
- STEEL DOORS ONLY: Bracket can be welded in place.



NOTE: If in doubt about the door's strength, reinforcement may be added to the door's frame where necessary. Door damage may occur if the bracket is installed on a panel with insufficient strength. The opener's warranty does not cover damage caused to the door and/or door panels.

Step 9 - Attaching the Arms

- Assemble the bent and straight arms with bolts and nuts supplied in the accessory pack (Fig.13). Always use both bent and straight arms.
- Connect the assembled arm to the bracket and the disengaged trolley with clevis and snap pins. The angle "A" must be more than 10° (Fig.13).



WARNING: Connecting the bent arm other way around may damage the door.



IMPORTANT NOTE: If the manual release handle is higher more than 6 feet (1.83m) from floor level when the operator is installed, extend the handle to a height 6 feet (1.83m) or less.

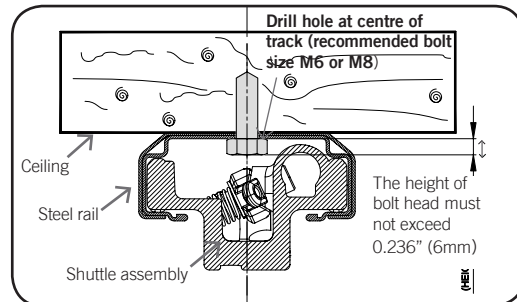

Fig.11

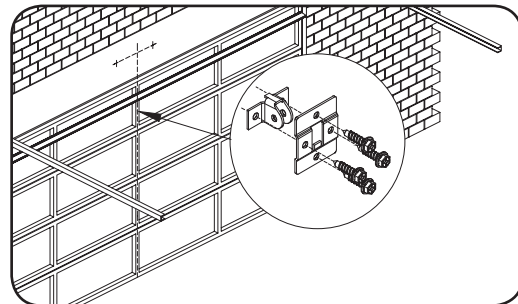

Fig.12

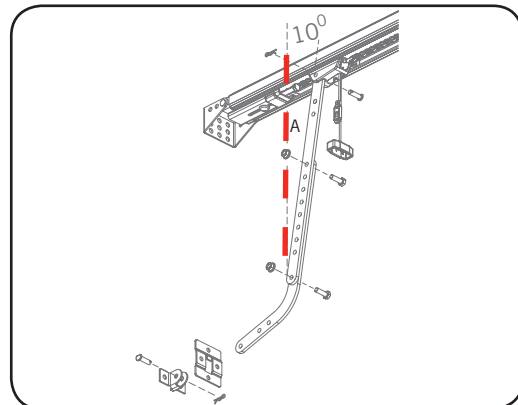

Fig.13

Safety Beam Installation

Fig.14

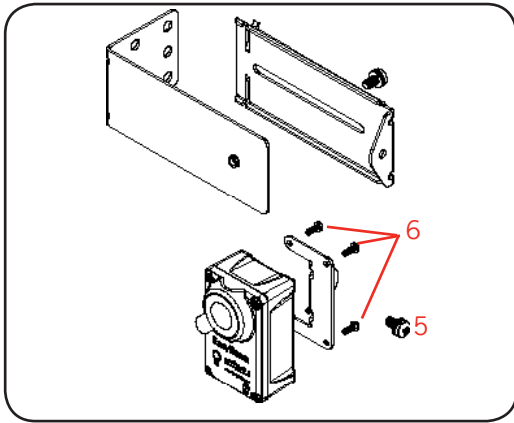

Fig.15

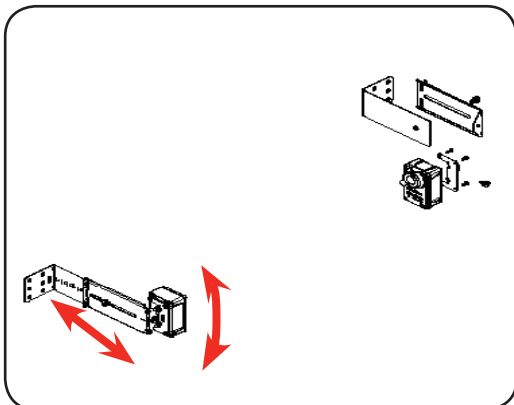
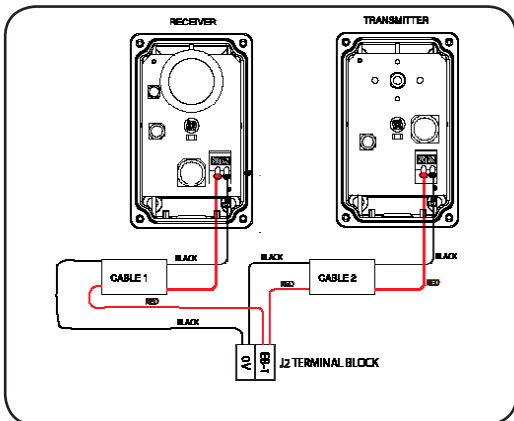

Fig.16



IMPORTANT NOTE: The Safety Beam must be installed and connected before the travel limits are set

Step 10 - Safety Beam

A Safety Beam extends across the door opening. This Safety Beam is designed to detect an obstruction while the door is closing and to send a signal to the door operator to reverse or stop the door movement.

Step 10.1 - Fitting the Safety Beam

- Attach the mounting bracket (4) to the adjustment bracket (3) with the pan head screw (5) (supplied). (Fig. 14).
- Attach the bracket (2) to the Safety Beam transmitter (PE3-V1-TX) (1) with four tap screws (6) (M3x5) and attach the other side to the adjustment bracket (3) with the pan head screw (5) (supplied).
- Repeat steps "a" and "b" to assemble the Safety Beam (PE3-V1-RX) receiver.
- Locate the Safety Beam in a strategic location in the door opening. **We recommends** that the sensor is placed no higher than 6" and no lower than 5" above the floor level. Connect as per the wiring diagram (Fig.16).

Step 10.2 - Alignment

- Power up the PA700 with the Beam connected. The green LED of the transmitter should be ON to indicate that power is present.
- If the receiver is connected properly and the red LED is flashing while the green LED of the transmitter is ON, the transmitter and receiver are not aligned.
- Make horizontal and/or vertical adjustment (Fig.15) on the transmitter and/or receiver until the red LED of the receiver turns steady on, indicating alignment.



WARNING: When the Safety Beam is fitted, the doorway must be clear of all obstructions and persons at all times. The location of the beams and manner in which it is installed might not give safety protection at all times. Check to make sure that the height of the beam and type used give maximum protection possible.



WARNING: Install the Safety Beam as per diagram in Fig. 16. Tampering with the Safety Beam could result in serious personal injury and/or property damage and will void the warranty.

Programming The Opener

Via Control Panel



IMPORTANT NOTE: The OPERATE button will not function until the open and close limit positions are set.



NOTE: The door and shuttle must be engaged into the chain index. The door should be open approximately half way.



NOTE: The Safety Beam must be installed before setting the travel limits.

Step 11.1 - Setting Limits Positions

Remove the controls cover to access the controls panel as shown in (Fig.17). Replace it when setup is completed.

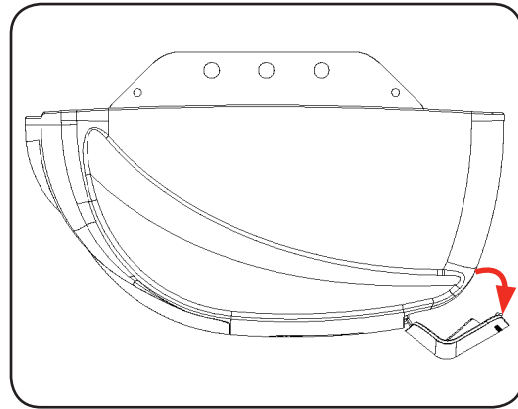

Fig.17

Step 11.2 - Connect Power to the Powerhead

Plug the power cord into a mains point and switch power on. The red CLOSE LIMIT LED will be flashing.



WARNING: The safety obstruction detection system is inoperable while MINUS (-) and PLUS (+) drive buttons are being used and travel limits are not set.

Step 11.3 - Set the Datum Position

- Press and hold the MINUS (-) or PLUS (+) buttons to move the door to the halfway position. Ensure that the door, shuttle and chain index are engaged.
- Using a small screwdriver, turn the DATUM ADJUST screw until the STATUS LED comes on (Fig.18).

NOTE: If the STATUS LED is already illuminated when the door is halfway up, turn the DATUM ADJUST screw until the light goes off, then turn back one notch to illuminate again.

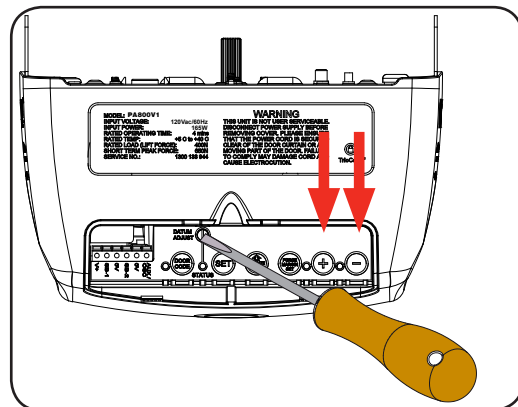

Fig.18

Step 11.4 - Set the Limits Positions

- Press and hold the MINUS (-) button until the door reaches the desired close limit position. Single presses will inch the door closed (Fig.19).
- Press the SET button to store the close position into memory (Fig.19).
- Press and hold the PLUS (+) button until the door reaches the desired open limit position. Single presses will inch the door open (Fig.19).
- Press the SET button to store the open position into memory (Fig.19).



WARNING: The door will automatically close, open and close again once Step 11.4(d) is performed. Ensure that no persons or objects are in the door's path.

- The door will now automatically close and open to calculate the safety obstruction settings. After this, the opener can be operated with the OPERATE button.

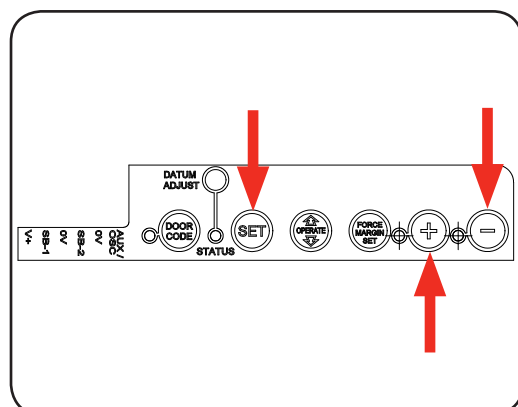
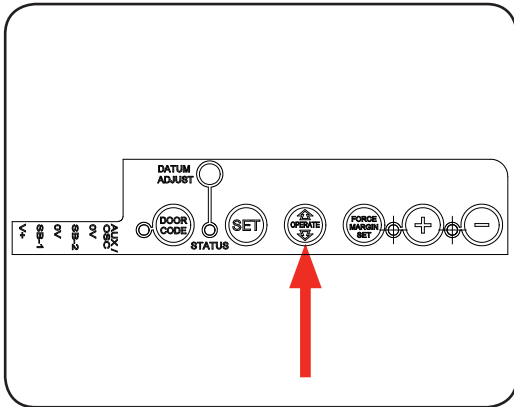

Fig.19

Testing Safety Obstruction Force

Fig.20



CAUTION: Take care when testing the Safety Obstruction Force. Failure to follow this warning can result in serious personal injury and/or property damage.

Step 12.1 Test the Close Cycle

- Press the OPERATE button to open the door (Fig.20).
- Place an object approximately 1-1/2" (38mm) high (or a 2"x 4" board laid flat) on the floor under center of garage door opening (Fig.21).
- Press the OPERATE button to close the door.
- When door contacts the object, the door must stop (within 2 seconds) and reverse to open position.

If the door does not properly reverse.

- Check the "close" limit position. It should not have reached its "close" limit before hitting board.
- If the door STOPS but does not reverse, decrease FORCE (refer to Step 12.4).

Step 12.2 Testing the Open Cycle

- Press the OPERATE button to close the door (Fig.20).
- Press again to open the door.
- When the door reaches approximately halfway, firmly grab the door's bottom rail - the door should stop.

If the door does not stop when opening, the force may be excessive and need adjustment, refer to 12.4.

Fig.21

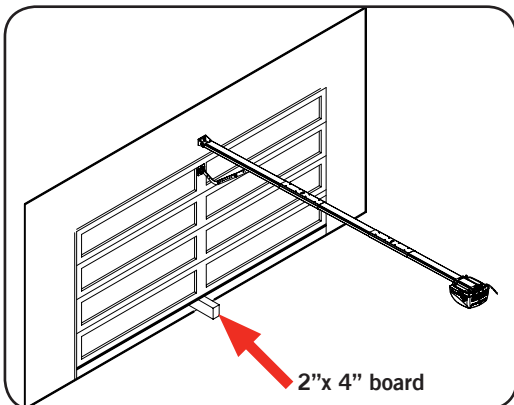

IMPORTANT WARNING: If the door is closing and is unable to re-open when obstructed, discontinue use. Do not use a door with faulty obstruction sensing. Repair fault and re-test before using.

Setting Safety Obstruction Force

Adjusting Safety Obstruction Force

The safety obstruction force is calculated automatically and normally does not require adjustment. The only time the force may need to be adjusted is due to environmental conditions, such as areas that are windy, dusty or have extreme temperature changes that affect the operability and movement of the door.



WARNING: Safety Beam must be installed if the closing force as measured at the bottom edge of the door exceed 200N (20kg).

Step 12.3 - To Increase Force Pressure (Fig.22)

- Press and hold the FORCE MARGIN SET button.
- While holding down the FORCE MARGIN SET button, press the PLUS (+) button. Each press will increase the force margin one step.
- The OPEN LIMIT LED will flash each time the PLUS (+) button is pressed to indicate an increase in force.
- If the OPEN LIMIT LED flashes continuously when the PLUS (+) button is being pressed, this indicates that the maximum force setting has been reached.
- Test the force again as per **Steps 12.1** and **12.2**.

Step 12.4 - To Decrease Force Pressure (Fig.23)

- Press and hold the FORCE MARGIN SET button.
- While holding down the FORCE MARGIN SET button, press the MINUS (-) button. Each press will decrease the force margin one step.
- The CLOSE LIMIT LED will flash each time the MINUS (-) button is pressed to indicate a decrease in force.
- If the CLOSE LIMIT LED flashes continuously when the MINUS (-) button is being pressed, this indicates that the minimum force setting has been reached.
- Test the force again as per **Steps 12.1** and **12.2**.

Step 12.5 - To Recall Factory Set Force

- While holding down the FORCE MARGIN SET button press the SET button for two seconds (**Fig 24**).
- Release both buttons. The default setting should now be recalled.

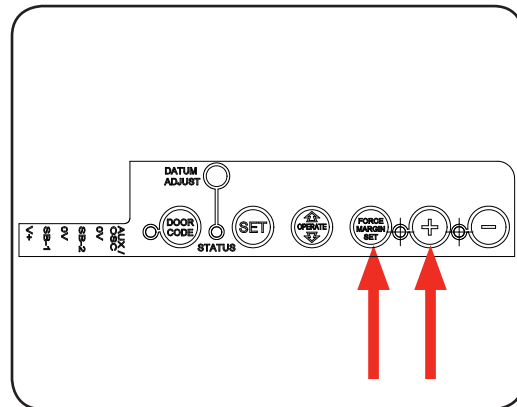

Fig.22

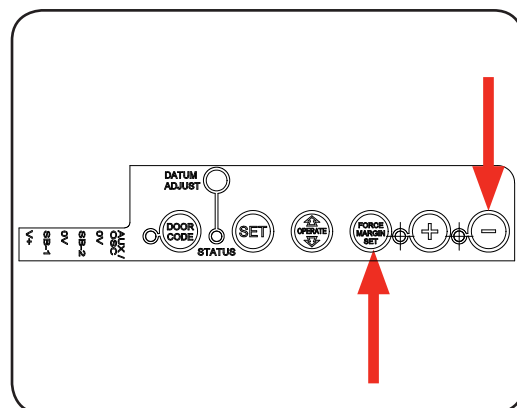

Fig.23

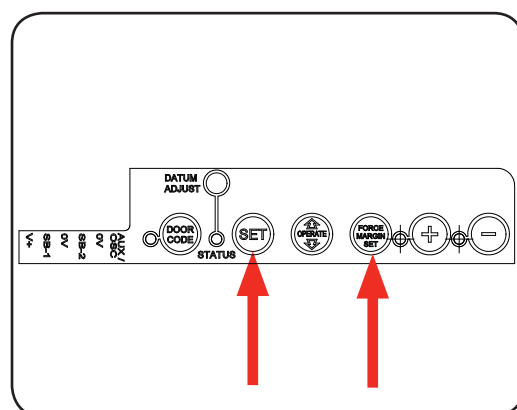

Fig.24

Coding Transmitters

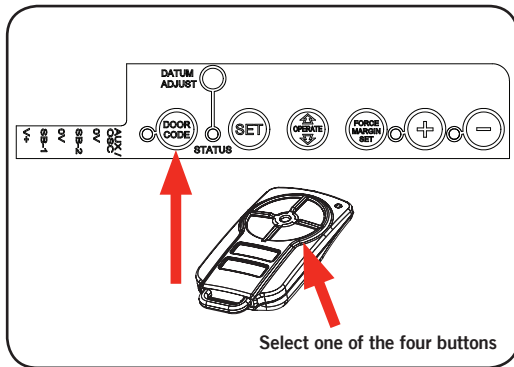

Fig.25

Step 13.1 - Coding a Transmitter Button for Door Operation (Fig.25)

The operator can only operate from transmitters that have been programmed into its receiver. The receiver needs to learn the codes of any transmitter that will be used with the operator. Up to eight (8) codes can be stored in the receiver's memory.

- Press and release the DOOR CODE button. The DOOR CODE LED will illuminate to indicate the opener is in Code Learn mode. If a valid code is not stored within 15 seconds the operator will exit Code Learn.
- Press one of the four buttons on the transmitter. The DOOR CODE LED will begin to flash.
- Press the same transmitter button again. The DOOR CODE LED will illuminate for one second and then go out.
- The transmitter is now coded to operate the door. Press that button to test again.

Step 13.2 - Setting the Transmitter to Operate the Courtesy Light (Fig.26)

Although the courtesy light comes on with each operation of the opener, it may also be controlled by a transmitter without operating the door.

- Press the DOOR CODE button twice. The DOOR CODE LED will illuminate and the courtesy light will turn on to indicate that the light code learning is active.
- Choose a transmitter button not already coded into the receiver. Press this button and the DOOR CODE LED will begin to flash.
- Press the same transmitter button again. The DOOR CODE LED will illuminate for one second and then go out.
- The transmitter is now coded to operate the light. Press that button to test again.

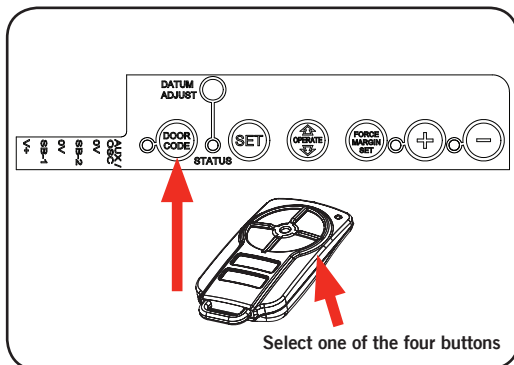

Fig.26

Transmitters Compliance Statement

Transmitters comply with all United States and Canadian legal requirements as of the date of manufacture. To comply with FCC Part 15 and or RSS 210 of Industry Canada (IC) rules, adjustment or modifications of this receiver and / or transmitter are prohibited, except for changing the code setting or replacing the battery. **THERE ARE NO OTHER USER SERVICEABLE PARTS.** Tested to Comply with FCC Standard FOR HOME OR OFFICE USE. Operation is subject to the following two conditions:

- (1) this device may not cause harmful interference, and
- (2) this device must accept any interference received, including interference that may cause undesired operation.

Coding Transmitters

Step 13.3 - Setting the Transmitter to Operate Vacation Mode (Fig.27)

The opener can be programmed into a "Vacation Mode" where the opener will not respond to any transmitter except one preprogrammed unit.

- Press DOOR CODE button three times. The DOOR CODE LED will illuminate and the courtesy light will flash slowly (once every two seconds) to indicate Vacation learning mode is active.
- Choose a transmitter button not already coded into the receiver. Press this button and the DOOR CODE LED will begin to flash.
- Press the same transmitter button again. The DOOR CODE LED will illuminate for one second and then go out, and the courtesy light will also switch off. This indicates the code has been stored.
- To activate Vacation Mode, close the garage door and press the coded button transmitter for 5 seconds. The DOOR CODE LED will illuminate to indicate that the opener is in Vacation Mode.
- To exit Vacation Mode press the transmitter button momentarily until the DOOR CODE LED turns off.

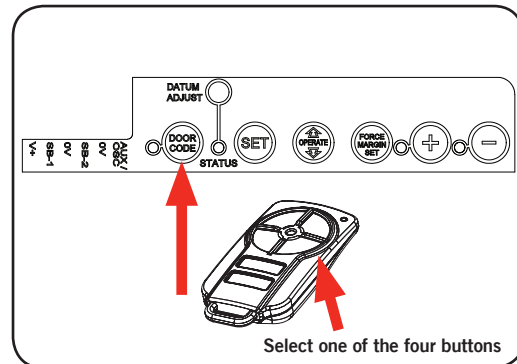

Fig.27

Step 13.4 - Setting the Transmitter to Operate the Auxiliary Output (Fig.28)

It is possible to operate other devices (e.g. alarm systems) using one of the spare buttons of a multi-channel transmitter coded into the Auxiliary Output feature.

- Press the DOOR CODE button four times. The DOOR CODE LED will illuminate and the courtesy light will flash quickly (twice per second) to indicate that learning mode for the Auxiliary Output is active.
- Choose a transmitter button not already coded into the receiver. Press this button and the DOOR CODE LED will begin to flash.
- Press the same transmitter button again. The DOOR CODE LED will illuminate for one second and then go out, and the courtesy light will also switch off. This indicates the code has been stored.

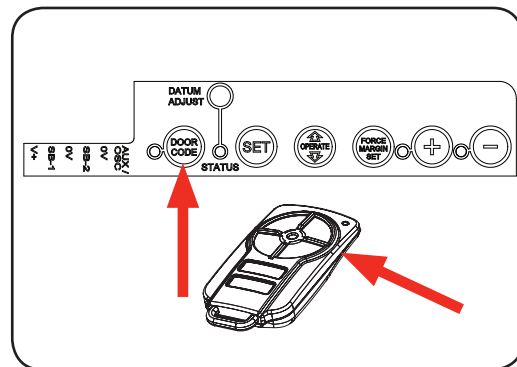

Fig.28

NOTE: This equipment has been tested and found to comply with the limits for a Class B digital device, pursuant to Part 15 of the FCC Rules. These limits are designed to provide reasonable protection against harmful interference in a residential installation. This equipment generates, uses and can radiate radio frequency energy and, if not installed and used in accordance with the instructions, may cause harmful interference to radio communications. However, there is no guarantee that interference will not occur in a particular installation. If this equipment does cause harmful interference to radio or television reception, which can be determined by turning the equipment off and on, the user is encourage to try to correct the interference by one or more of the following measures:

- Reorient or relocate the receiving antenna
- Increase the separation between the equipment and receiver
- Connect the equipment into an outlet on a circuit different from that to which the receiver is connected
- Consult your local dealer or an experienced radio/TV technician for help.

Coding Transmitters

Fig.29

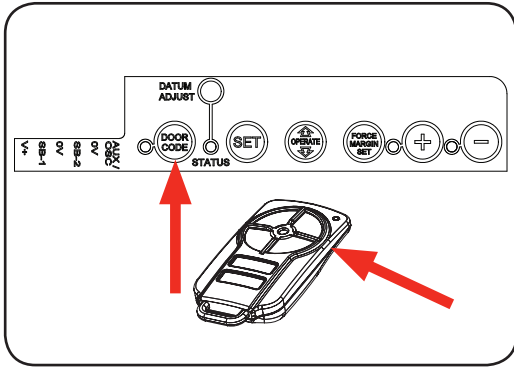

Fig.30

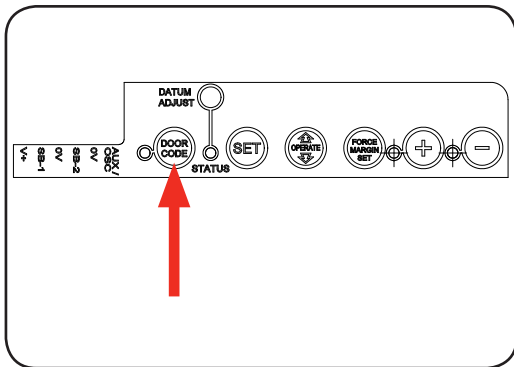
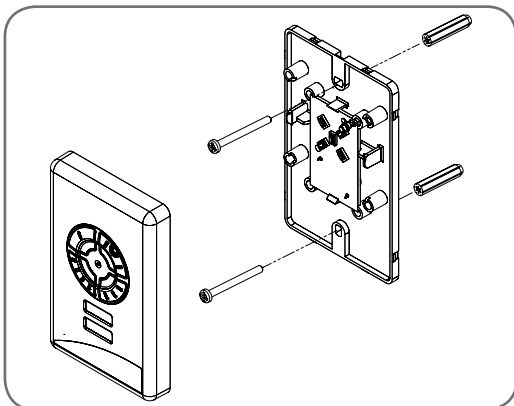

Fig.31



Step 13.5 - Setting the Transmitter to Operate Pet (Pedestrian) Mode (Fig.29)

The operator can be programmed into a "Pet Mode" where the door opens partially to allow pets to enter/exit the garage:

- Press the DOOR CODE button five times, the DOOR CODE LED will illuminate and the courtesy light will flash quickly (twice per second) to indicate learning mode for Pet Mode is active.
- Choose a transmitter button not already coded into the receiver. Press this button and the DOOR CODE LED will begin to flash.
- Press the same transmitter button again. The DOOR CODE LED will illuminate for one second and then go out, and the courtesy light will also switch off. This indicates the code has been stored. This indicates the code has been stored.
- The opening height of the door for pet position can only be changed with a universal programmer.

Step 13.6 - To Erase Programmed Codes (Fig.30)

If the DOOR CODE button is pressed and held for 6 seconds the DOOR CODE LED will blink rapidly for one second to indicate that all programmed codes have been erased.

Step 13.7 - Installation of the Wall Mounted Transmitter (Fig.31)

- Mount the transmitter in a convenient location, yet out of reach of children and **at least 5 feet (1.53m)** off the ground, and
- Away from all moving parts of the door.
- Make sure the door is visible from this location.
- To set the transmitter codes, refer to **Step 13.1**.



NOTE: The manufacturer is not responsible for any radio or TV interference caused by unauthorized modifications to this equipment. Such modifications could void the user's authority to operate the equipment.

Accessories

Terminal Block

A variety of wired accessory items can be connected to the terminal block **J2** such as Safety Beam, Electric Key Switch and more (Fig.32).

The terminal block **J2** also features auxiliary output for controlling other devices from your transmitter. These can include: an alarm system, additional mega code receiver or an automatic gate.

Terminal **J2** connections from top to down are as follows:

1. **V+** (+35V/+24V);
2. **SB-1** (Safety Beam input, mandatory);
3. **0V** (0V for Safety Beam);
4. **SB-2** (Safety Beam input);
5. **0V** (Common ground for accessories and Safety Beam);
6. **AUX** (Auxiliary output trigger)/ **OSC** (Open/Stop/Close trigger).

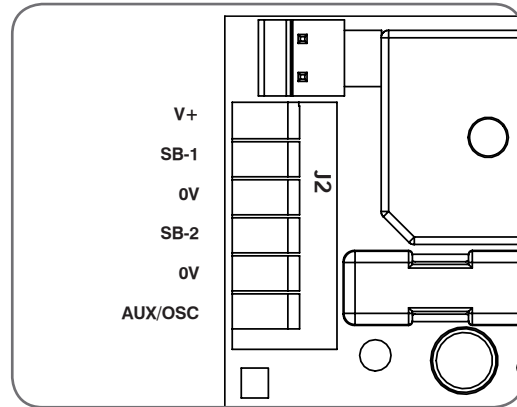

Fig.32

Remote Aerial

Some sites cause poor radio reception. Particularly problematic areas are those where there is a large amount of metal, like an all steel garage, or an underground car park with large masses of steel reinforced concrete. These issues, and others, can create radio reception issues.

Poor radio reception will be noticed by a reduction in the operating range of the transmitters.

You can evaluate whether fitting an external aerial will benefit as follows:

- test the maximum operating range of the transmitter with the garage door closed; then
- test the maximum operating range of the transmitter with the garage door open.

If the range improves when the door is open you can install a remote aerial kit to improve reception.

Mount the aerial to a suitable location on the outside of the garage. Similar to a television aerial, the better the mounting position the better the reception will be. Where possible, mount the aerial as high as possible, away from masses of metal and in a line of sight position to where you normally use your transmitter.

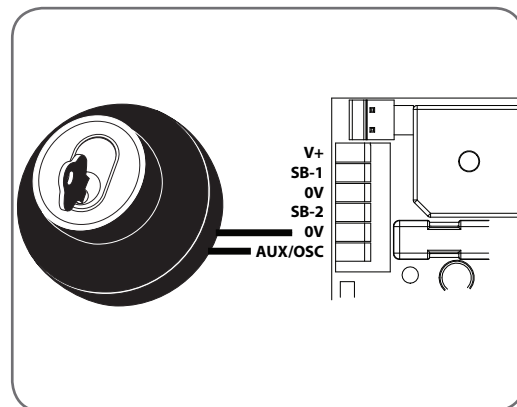

Fig.31

Auxiliary / Key Switch Connection

Auxiliary / Key Switch terminal can either be used to connect a key switch or to use as an auxiliary output. An Key Switch provides an alternative to using a transmitter. Each key turn cycles through an open/stop/close function. The electric key switch is also an external release mechanism, it is ideal for garages with one entrance only. To connect the key switch to the opener's terminal block refer to Fig.31.

The Auxiliary Output can be used to control alarm or another garage door operator with the existing garage door remote control. A valid transmission from the pre-coded transmitter will cause the AUX output to pulse for 1 sec. The maximum DC voltage must not exceed 35V. Maximum current must not exceed 80mA. Connect the auxiliary output as per Fig.32.

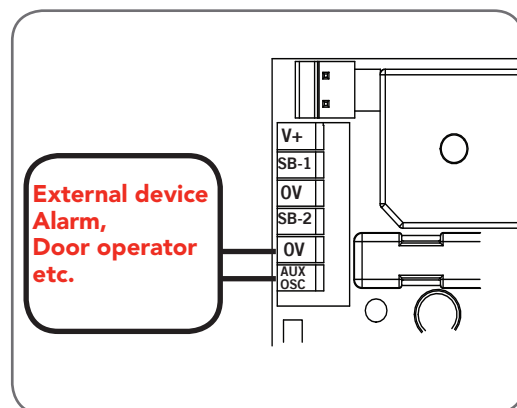

Fig.32

How To Use Your Operator

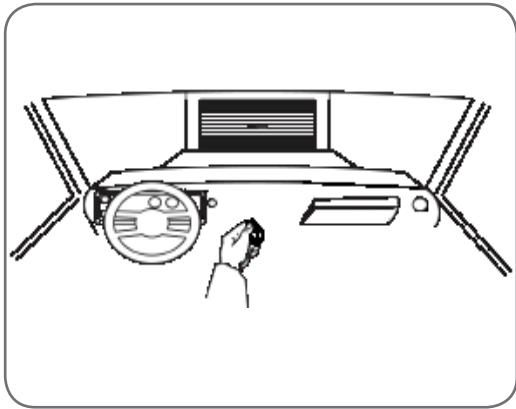

Fig.33

For maximum efficiency of your operator, your garage door must be in good operating condition.

An annual service of your garage door by a garage door professional is recommended.



CAUTION - Activate the operator only when the door is in full view, free of obstructions and with the operator properly adjusted. No one should enter or leave the garage while the door is in motion. Do not allow children to play with or near the door.



WARNING! This operator is a mains voltage plug-in domestic appliance and there are no user serviceable parts inside this operator.

Transmitter

- To operate the operator, press the programmed transmitter button until your door begins to move (usually 2 seconds). Make sure you can see the door when you use the transmitter.
- If you are in a vehicle you should aim the transmitter through your windscreen (Fig.33).
- Check that the door is fully closed before you drive away.
- If you press the transmitter whilst the door is moving the door will stop. The next press of the transmitter will move the door in the opposite direction.

The transmitter may also be programmed to operate the following features (see **Pages 18 to 20** for full details):

- to turn the courtesy light on and off without operating the door,
- to activate the Auxiliary Output,
- to put the door into "Pet Mode" where it opens partially to allow pet access to the garage, and/or
- to put the garage door opener into "Vacation Mode" where it will not respond to any transmitters.

NOTE: Additional transmitters may be purchased at any time.

How To Use Your Operator

Removing the Battery From the Transmitter

(Battery Type: 3V Lithium Battery CR2032).

Use a non-metallic object (e.g. pen) to remove the battery. (Fig.34)

In-built Locking Facility

DO NOT lock your door when your operator is engaged as it has in-built locking facility. With the operator engaged your door will be locked whether the power is on or off.

Manual Door Operation



CAUTION: when operating the manual release while the door is open. The door may fall rapidly due to weak or broken springs, or due to being improperly balanced.



CAUTION! Do not disengage the operator to manual operation with children/persons or any objects including motor vehicles within the doorway.

To disengage the operator from the door (preferably with the door in the closed position), pull down on the string handle on an angle towards the door. This will allow you to manually open or close the door. To re-engage the operator pull the string handle away from the door.



WARNING! When the operator is manually disengaged, the door is no longer locked. To lock the door manually, re-engage the operator after the door is closed.

Power Failure

When there is a power failure, the operator will be unable to automatically open or close your garage door. To use your door whilst there is no power you will need to disengage the operator and use the door manually – see Manual Operation above.

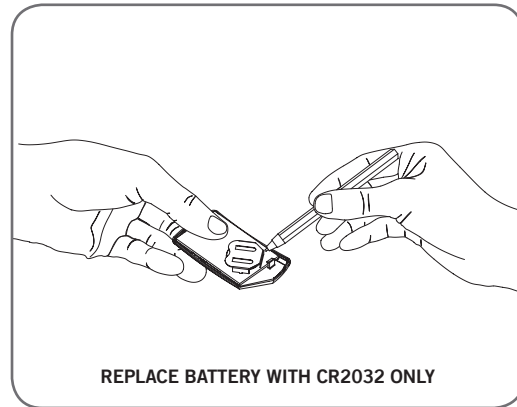

Fig.34

How To Use Your Operator

Safety Beam

A Safety Beam Kit must be fitted to this operator.

- When this Kit is fitted, the operation of this device is such that if an object (i.e. car, child, etc.) blocks the Safety Beam, then the garage door operator will not close the door automatically.
- When the Safety Beam is fitted but not operating correctly, then the door once opened automatically, will not close automatically. The door may be closed by reverting to manual operation – see Manual Operation.

Courtesy Light

The Courtesy Light will illuminate for approximately three (3) minutes each time the door is operated automatically. Spare buttons of a multi-channel transmitters can be programmed to turn the light on and off by remote control. See **Step 13.2** for more information.

Auxiliary (AUX) / Operate (OSC) Output

The Auxiliary Output allows the opener to operate other devices such as another opener or an alarm system.

To use this function, a spare button of a multi-channel transmitter must be programmed to operate the Auxiliary Output feature.

See **Step 13.4** for more information.

The Operate (OSC) function allows the operator to open/stop/close the door. Connect a normally open switch to this input for operation.

Vacation Mode

The radio receiver of the garage door operator can be turned off to all but one transmitter via Vacation Mode. Whilst in vacation mode the operator will not respond to any transmitter.

To activate the Vacation Mode facility, see **Step 13.3**.

NOTE: program only one button to control "Vacation Mode". This will reduce the possibility of accidental activation of this feature.

Pet (Pedestrian) Mode

A transmitter can be programmed to open the door partially to allow pet access to the garage.

To activate Pet Mode press the transmitter button that has been programmed for Pet Mode - The door will open partially.

See **Step 13.5** for more information.

Maintenance

The SERVICE LED will indicate the requirement for a service and/or adjustment. To reset the SERVICE LED when the door is serviced, reprogram the Door Travel Limits and the Door Travel Force – on completion of this programming the SERVICE LED will go out.

Whilst your operator does not require any periodic maintenance, the door that it is fitted to does. Your garage door is a large, heavy, moving object and should be tested regularly to ensure it is in good condition. A poorly maintained door could cause fatal or serious injuries or serious damage to property.

To ensure a long and trouble free life for your operator the following is recommended:

Monthly

- Disengage the operator and manually operate the door: The door must be smooth to operate by hand. An operating force on the bottom rail should not exceed 150N (15kg (33lbs)) force.
- Each month check that the operator reverses when the door contacts a 1-1/2" high object placed on the floor. Refer to the Safety System (Pages 16-17).

NOTE: If the door does not operate smoothly or the safety reverse test failed, **CONTACT A TRAINED DOOR SYSTEM TECHNICIAN.**

Yearly

We suggest that you contact your nearest garage door professional to perform an annual door service.

Service Record

Record any maintenance in the following table to assist in any warranty service.

Date	Service by	Signature	Invoice No.	Amount



CAUTION: Frequently examine door, particularly cables, springs and mountings for signs of wear, damage or imbalance. Do not use if repair or adjustment is needed since a fault in the installation or an incorrectly balanced door may cause injury.

Adjustments should only be carried out by experienced persons, as this function can be dangerous if not performed under strict safety procedures.



WARNING! Failure to maintain your garage door may void the warranty on your garage door operator.

Warranty Expired Indicator
 When the operator reaches the number of cycles covered by warranty the courtesy light will flash 10 times after each operation to indicate that the warranty has expired. This flashing will continue for twenty (20) operations unless the user acknowledges the warranty expiry indicator and stops the light from flashing. To stop the courtesy light flashing press the SET button while the light is flashing after an operation.

Troubleshooting Guide

Symptom	Possible cause	Remedy
The opener does not work from the transmitter	Garage door in poor condition e.g. springs may be broken	Check the door's operation - see monthly maintenance (Page 25)
	The opener does not have power	Plug a device e.g. a lamp, into the power point and check that it is OK
	The battery in the transmitter is flat	Replace the battery (Page 23)
	The opener has been put into "Vacation Mode"	Turn off "Vacation Mode" (Page 19)
	The transmitter code has not been set properly	See transmitter & code setting procedure (Page 18)
The motor runs but the door does not move	The opener is disengaged	Re-engage the opener (Page 23)
The transmitter range varies or is restricted	Variations are normal depending on conditions e.g. temperature or external interference	See instructions for correct use of transmitter (Page 22)
	The battery is flat or faulty	Replace the battery (Page 23)
	Position of the transmitter in the motor vehicle	Change the position (Page 22)
	Position of the aerial will not pick up the radio signal	Install an external aerial kit – see Accessories (Page 21)
The light does not work	Light module is not inserted/connected properly	Check for correct connection otherwise contact a garage door professional for support
The door reverses for no apparent reason	This may occur occasionally from weather changes	The opener automatically adjusts to compensate for changes, to adjust the force see (Pages 16, 17)

If You Need a Service Call

If the opener needs service, call the dealer who installed the garage door operator (for product assistance contact).

BEFORE CALLING you should have the following information to assist in providing the appropriate service:

1. Has anything happened since the operator last operated OK, e.g. a storm, a jolt to the door etc.?
2. How easy is it to manually open and close the door?
3. What model is the operator?
4. Who installed the operator?
5. When was it installed?

Fault Indicator

When a fault is detected the SERVICE LED will start to flash and a number of beeps will sound to indicate that there is a fault. The fault will be active each time an attempt is made to operate the door.

Pressing the SET button will reset the opener. If the fault continues to be tripped contact a garage door professional for assistance.

Parameters

Door status indicators

Door opener state	OPEN LED (green)	CLOSE LED (red)	Beeper
Open	On		
Close		On	
Opening	Flashing		
Closing		Flashing	
Door travel stopped	Flashing	Flashing	
Door obstructed when opening	Flashing		
Door obstructed when closing		Flashing	Beeps while door is moving
Opener overloaded	Alternating flashes	Alternating flashes	
Mains power interrupted	Rapid flashes		

Button	Function
OPERATE	Opens/stops/closes the door
DOOR CODE	Codes a transmitter button for operate function
FORCE MARGIN SET & PLUS (+)	Increases the obstruction force margin setting
FORCE MARGIN SET & MINUS (-)	Decreases the obstruction force margin setting
FORCE MARGIN SET (then) SET	Reloads the factory set default obstruction force margin setting
(-) (for 6 seconds)	Clears the door limits set positions. Limits then need to be reset
SET press and hold until all LEDs are off	Deletes control parameters excluding transmitter storage memory
DOOR CODE press and hold until DOOR CODE LED starts flashing	Deletes all transmitter storage memory
SET & DOOR CODE press and hold until all LEDs are off	Deletes all control parameters and transmitter storage memory

Spare parts list

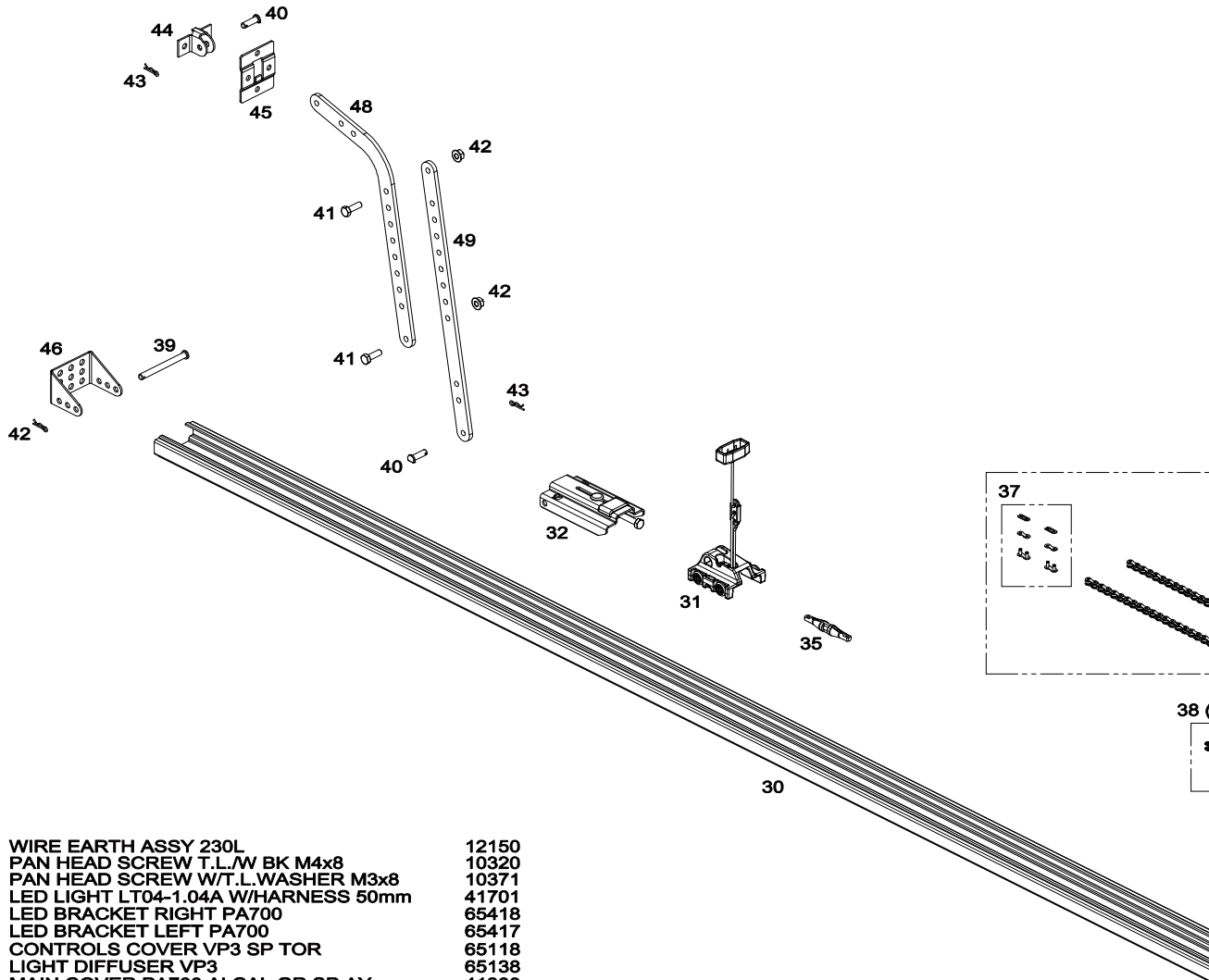

29	WIRE EARTH ASSY 230L	12150
28	PAN HEAD SCREW T.L./W BK M4x8	10320
27	PAN HEAD SCREW W/T.L.WASHER M3x8	10371
26	LED LIGHT LT04-1.04A W/HARNESS 50mm	41701
25	LED BRACKET RIGHT PA700	65418
24	LED BRACKET LEFT PA700	65417
23	CONTROLS COVER VP3 SP TOR	65118
22	LIGHT DIFFUSER VP3	65138
21	MAIN COVER PA700 ALCAL GR SP AY	41300
20	CAP POLYFILM 0.1UF K X2 275VAC	67575
19	TERMINAL BLOCK 500/02DS	65421
18	PAN HEAD SCREW W/T.L.WASHER M3x14	10361
17	TRANSFORMER-7551-F_72VA-120V-25VAC AY	40902
16	TERMINAL BLOCK SHIELD	14057
15	PA800 C.B. DCB07-2.04A-000B	41605
14	WIRE GUIDE VP3	64891
13	TAPTITE SCREW "S" RoHS PF THD M4x10	10504
12	TAPTITE SCREW "S" RoHS PF THD M4x8	10503
11	PAN SERRATION HEAD SCREW M4x12	10380
10	TAPTITE SCREW "P" M4x10	10570
9	FLANGE BUSH I.D.4.5	64332
8	RATCHET TIMING VP3_2 AY	61728
7	TIMING SUP GMA-18 (S-ALP)	16231
6	HELICAL GEAR 5911_121670	64062
5	GEARED MOTOR GMA-19-59-Y75	60337
4	POWER CORD U.S. 1.5m W2PIN+1RING	65672
3	CORD GRIP GROMMET SB5P-2	65606
2	GROMMET 101422	65603
1	METAL CHASSIS VP4	72005

49	STRAIGHT ARM	62790
48	BENT ARM	62800
47	TRACK BRACKET VP2	64592
46	WALL BRACKET_TS01	62522
45	DOOR BRACKET LOCATOR	62515
44	DOOR BRACKET	62511
43	PIN SNAP SSP 8 ZNU 31080	10720
42	HEX SERRATION FLANGE NUT M8	10148
41	HEX HEAD SCREW M8x25	10110
40	CLEVIS PIN 0829	62551
39	PIN 0890	65790
38	CHAIN CLIP IM KIT	71643
37	CHAIN JOINT LINK	62950
36	CHAIN 1/2"x1/8" (487 LINKS) W/2CL	63005
35	CHAIN INDEX V3	62941
34	SPROCKET SUPPORT_TS01	64921
33	SPROCKET 12T-12.7_TS01	64698
32	TENSION CHAIN ASSY_TS01	61453
31	SHUTTLE ASSY_TS01	60276
30	C RAIL TRACK 77.8x31.8x3160_TS01	64653

ITEM NO.	DESCRIPTION	ORDER CODE	ITEM NO.	DESCRIPTION	ORDER CODE
----------	-------------	------------	----------	-------------	------------

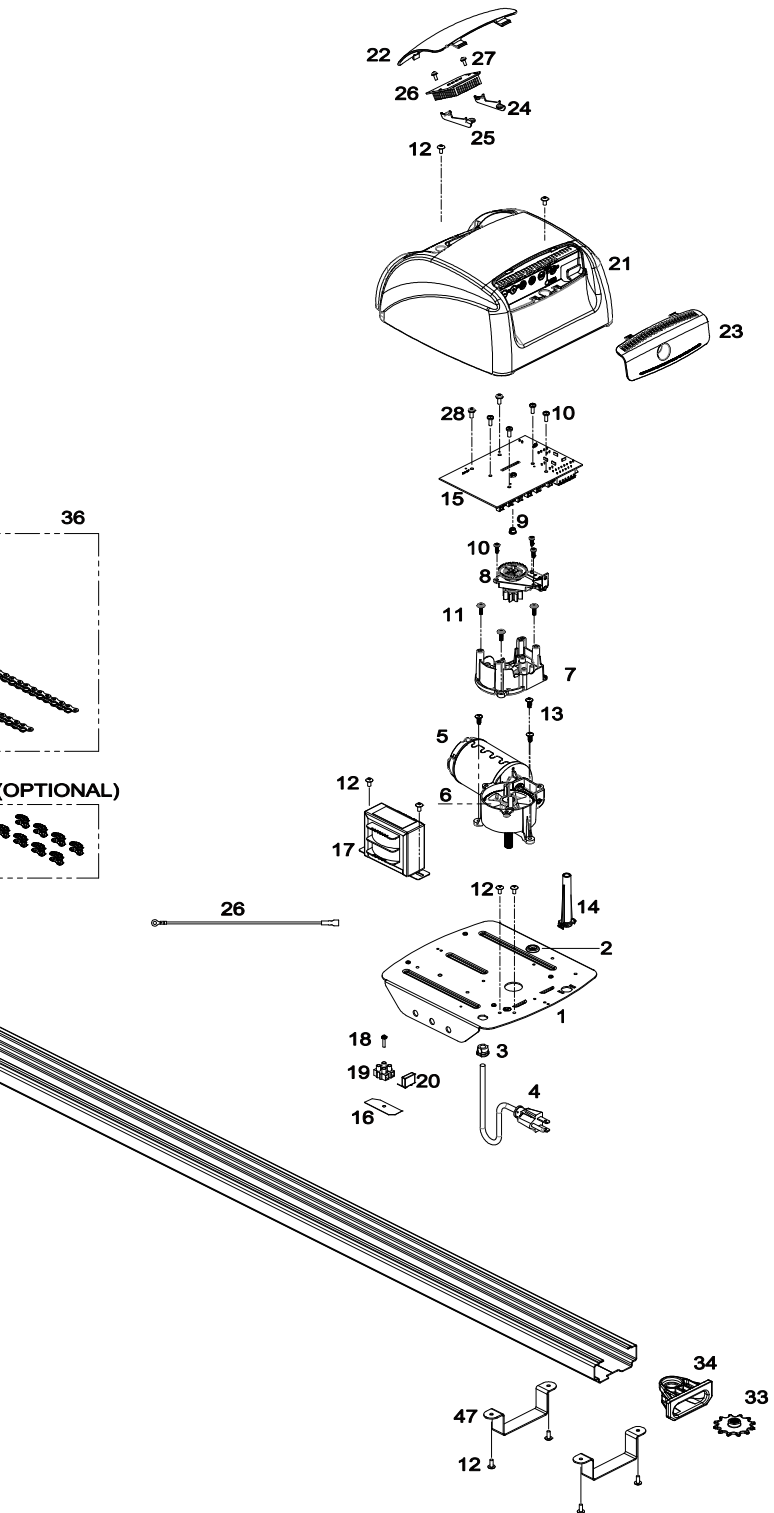

Warranty

1. Definitions

'Purchaser' means the purchaser of the Operator.

'Operator' means the 'PA700 Automatic Garage Door Operator'

'Authorised Distributor' means an authorised distributor of the Operator.

'Major Components' means all components of the Operator that make up the powerhead that is attached to a garage door.

'Ancillary Components' means all components of the Operator which are not Major Components.

'Manufacturer's Written Instruction Manual' means the instruction manual provided with the Operator.

2.

Warranty

Purchased From: _____

Installed By: _____

Installed Date: _____

The Purchaser shall complete this certificate and keep it together with a copy of the receipt of purchase in a safe place – production of such information will assist the handling of a claim made under this warranty.

Optional Accessories

There is a range of additional accessories for your added convenience and security.

- **Keyring Transmitter** - Ideal for personal use when entry into the house may be via the garage.
- **Transmitter Wall Button** - Allows you to operate the operator within 32.8ft (10 metres) of the door. Ideal for mounting inside the house.
- **Combo Access Kit** - Keyswitch function will open the door without a transmitter. Can be used to manually disengage the operator, and recommended when the garage door is the only access to the garage.
- **Remote Aerial Kit** - For sites where radio range may be reduced.

Contact your garage door professional for installation of these accessory items.



When installing any accessories, always follow the instructions included with the product.



Only our accessories purchased from a garage door professional offer the highest quality and assure you of trouble free opener operation.

