

## ARS2-A, ARS2-B, ARS2-C, ARS3-A & ARS3-B Adaptive Cruise Control Radar System (Distronic)



### A.D.C.

Automotive Distance Control Systems GmbH

Peter-Dornier Str. 10

D-88131 Lindau / Germany

Phone: +49-8382-9699-0 Fax: +49-8382-9699-19

# Instruction Manual

---



<http://www.temic.com>

## Contents

DISTRONIC (DTR)	3
Activation of DISTRONIC	7
Invalid attempts to activate	8
Deactivation of DISTRONIC	9
Driving with DISTRONIC activated	10
Additional driving hints	11
Distance notification functions	15
DISTRONIC settings	16
Multifunction display	17
Displays in the speedometer dial	18
Operation in the USA	19
Cleaning the DISTRONIC system sensor	20
ARS2-A, ARS2-B, ARS2-C, ARS3-A Sensor Overview	21

## Distronic (DTR)

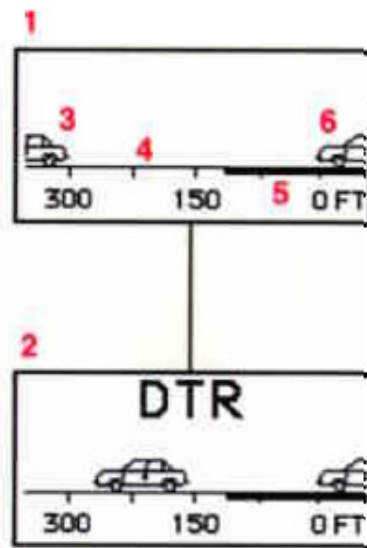

PS4.30-3752-26

- 1 Distronic (DTR) is deactivated. The actual distance (4) and the should-be distance (5) to the vehicle in front (3) are displayed.
- 2 Distronic (DTR) is activated.  
The message “DTR OFF” appears for five seconds when Distronic is being deactivated.
- 3 Vehicle ahead. Only appears if a vehicle is detected ahead.
- 4 Actual distance to vehicle ahead.
- 5 Should-be distance to vehicle ahead.
- 6 Own vehicle.

Press the  or  button repeatedly until the required system is displayed.

Pressing the  or  button displays the next or previous system.

## **Distronic (DTR) (optional)**

When activated the Distronic system increases driving convenience, for example over long distances, as it automatically maintains a speed set by the driver by actively regulating the throttle setting. It also maintains within certain limitations a preset distance to a vehicle ahead.

With Distronic switched off, the multifunction display continues to show the distance to the vehicle ahead, if so selected

The distance notification function can be activated separately

In Distronic mode, if the distance sensor detects a slower moving vehicle directly ahead, your vehicle speed will be reduced to the extent permitted by reduced throttle and up to 20% of vehicle braking power, so that you follow that vehicle at a preset distance. Maximum range of detection is approximately 500 ft. (150 m).

Any given speed between 25 mph (Canada: 30 km/h) and 110 mph (Canada: 180 km/h) can be maintained with the Distronic by operating the control lever on the steering column.

### **Warning!**

**Distronic is a convenience system, its speed adjustment reduction capability is intended to make cruise control more effective and usable when traffic speeds vary. It is not, however, intended to nor does it replace the need for extreme care. The responsibility for the vehicle speed and the distance to the vehicle ahead, including most importantly brake operation to assure safe stopping distance, rests always with the driver.**

### **Warning!**

**Distronic requires familiarity with its operational characteristics. We strongly recommend that you review the following information carefully and that you fully review the Distronic introduction video included with your vehicle before operating the system.**

## Note:

For operation in the USA only: This device complies with Part 15 of the FCC Rules. Operation is subject to the following two conditions:

- (1) This device may not cause harmful interference, and
- (2) this device must accept any interference received, including interference that may cause undesired operation.

Any unauthorized modification to this device could void the user's authority to operate the equipment

## Warning!

**Only use Distronic if the traffic and weather conditions make it advisable to travel at a steady speed.**

**Use of Distronic can be dangerous on winding roads or in heavy traffic because conditions do not allow safe driving at a steady speed.**

**Use of Distronic can be dangerous on slippery roads. Rapid changes in tire adhesion can result in wheel spin and loss of control.**

**Distronic does not act upon adverse sight distance conditions. Do not use Distronic during conditions of fog and heavy rain, snow or sleet.**

**The "Resume" function should only be operated if the driver is fully aware of the previously set speed and wishes to resume this particular preset speed.**

**Distronic does not recognize accordingly and will not react to stationary objects. It is designed and intended only to maintain a set speed and keep a set distance from moving objects in front of it.**





The speed stored in memory is displayed in the multifunction display, and one or two segments around the stored speed light up in the speedometer dial

**1 Accelerate and set:**

To increase the speed by 5 mph (Canada: 10 km/h) – briefly lift lever up.

**2 Decelerate and set:**

To reduce the speed by 5 mph (Canada: 10 km/h) – briefly depress lever.

**3 Canceling**

To cancel Distronic, briefly push lever to position 3. The last set speed remains stored in memory.

**4 Resume**

- If the lever is briefly pulled to position 4 when driving at a speed above approx. 25 mph (Canada: 30 km/h), the vehicle resumes the speed which was selected prior to the cancellation of Distronic.
- For minor increases of speeds in increments of 1 mph (Canada: 1 km/h) – briefly pull lever to position 4.

The last memorized speed is canceled when the electronic key in the starter switch is turned to position 1 or 0.

## Activation of Distronic



Any given speed above approximately 25 mph (Canada: 30 km/h) can be maintained:

- Normally the vehicle is accelerated to the desired speed with the accelerator.

- Speed is set by briefly moving the control lever to position 1 or 2.

The stored speed is displayed in the multifunction display for approx. 5 seconds and one or two segments around the stored speed light up on the speedometer dial

- Remove foot from the accelerator.
- When briefly lifting the control lever to position 1, the vehicle speed will increase in increments of 5 mph (Canada: 10 km/h).

The stored speed is displayed in the multifunction display for approx. 5 seconds and one or two segments around the stored speed light up on the speedometer dial

- When briefly lowering the control lever to position 2, the vehicle speed will decrease in increments of 5 mph (Canada: 10 km/h).

The stored speed is displayed in the multifunction display for approx. 5 seconds and one or two segments around the stored speed light up on the speedometer dial



- For a more precise setting the speed can be increased in increments of 1 mph (Canada: 1 km/h) by briefly pulling the control lever in direction (4).

## Caution!

If the driver's foot is not fully removed from the accelerator pedal, the DISTRONIC control system will be overridden and it will not regulate the preset vehicle speed and following distance. The vehicle speed and following distance will be determined only by the accelerator pedal position.

## Warning!



**DISTRONIC brakes (up to 20% of vehicle braking power) the vehicle to restore the preset distance or to maintain the speed. The brake pedal is automatically retracted as this happens.**

**Keep driver's foot area clear at all times, including the area under the brake pedal. Objects stored in this area may impair pedal movement which could interfere with the braking ability of the DISTRONIC system.**

**Do not place your foot under the brake pedal – your foot could become caught.**

## Invalid attempts to activate

The multifunction display will show “---” during invalid attempts to activate DISTRONIC:

- below a speed of approx. 25 mph (Canada: 30 km/h).
- while the electronic stability program (ESP) is switched off – ESP warning lamp  in speedometer dial is illuminated
- by moving the DISTRONIC control lever in “RESUME” direction (4) when no speed is stored in memory.
- during the initialization and self-test phase after the engine is started – this can take up to 2 minutes.
- while depressing the service brake pedal.
- while the parking brake is set – check  warning lamp (Canada: ) in instrument cluster,
- with the gear selector lever in position “P”, “R” or “N” – check gear range indicator display in instrument cluster,

## Deactivation of Distronic

Briefly move the distronic control lever in “OFF” direction (3) – the stored speed remains in the memory until the electronic key in the starter switch is turned to position 1 or 0.

Distronic is also deactivated if:

- the service brake pedal is depressed.
- the parking brake is activated.
- the vehicle decelerates to less than approximately 25 mph (Canada: 30 km/h), e.g. while maintaining the distance to the vehicle ahead.

## Warning!

**The Distronic switches off and releases the brakes when the vehicle decelerates below the minimum speed of 25 mph (Canada: 30 km/h) by operation of the system. At that time, the driver must apply the brakes in order to reduce vehicle speed further or bring it to a stop.**

- the gear selector lever is moved to position “N”.
- the electronic stability program (ESP) is active.
- the electronic stability program (ESP) is switched off manually.
- Model CL 55 AMG only:  
the vehicle speed exceeds approximately 160 mph (260 km/h).

## Note:

A signal sounds and the message “DTR OFF” appears for 5 seconds in the multifunction display everytime Distronic is deactivated.

## Driving with Distronic activated



With the electronic key in starter switch position 2, the distance warning lamp I in the speedometer dial comes on and goes out with the engine running.

If the distance sensor detects a slower vehicle moving in front, your vehicle speed will be reduced by deceleration and braking of up to 20% of the vehicle braking capacity, so that you follow the vehicle ahead at the preset distance. Segments in the speedometer illuminate to indicate the speed range

from the speed of the vehicle in front up to your vehicle's selected speed.

### Warning!

**Distronic brakes (up to 20% of vehicle braking power) the vehicle to restore the preset distance or to maintain the speed. The brake pedal is automatically retracted as this happens.**

**Keep driver's foot area clear at all times, including the area under the brake pedal. Objects stored in this area may impair pedal movement which could interfere with the braking ability of the Distronic system.**

**Do not place your foot under the brake pedal - your foot could become caught.**

## **Warning!**

**A continuous warning sounds and the distance warning lamp in the speedometer dial is illuminated if the Distronic system calculates that the distance to the vehicle ahead and your vehicle's current speed indicate that Distronic will not be capable of slowing the vehicle sufficiently to maintain the preset following distance, which creates a danger of a collision.**

**Immediately brake the vehicle to increase the distance to the vehicle in front of you. The warning sound is intended as a final caution that you have not interceded with your own braking inputs to avoid a potentially dangerous situation. Do not wait for the operation of the warning signal to intercede with your own braking as that will result in potentially dangerous emergency braking which will not always result an impact being avoided.**

**Tailgating increases the risk of an accident.**

The distance warning sound continues until the driver activates the brake pedal, or the preset distance is obtained. As soon as the preset distance is obtained, the distance warning lamp goes out.

## **Caution!**

If the driver's foot is not fully removed from the accelerator pedal, the Distronic control system will be overridden and it will not regulate the preset vehicle speed and following distance. The vehicle speed and following distance is determined only by the accelerator pedal position.

Distronic works on steep uphill and downhill gradients by downshifting gears and applying the brakes to maintain the speed selected by the driver. The transmission will upshift again once the gradient evens out.

The speed can be increased (e.g. for passing) by using the accelerator. After the accelerator is released, the previously set speed will be resumed automatically.

Distronic is deactivated if a vehicle in front causes your vehicle to slow down to less than approx. 25 mph (Canada: 30 km/h). A signal sounds and the message "DTR OFF" appears for 5 seconds in the multifunction display.



## Additional driving hints

### Warning!

**Distronic works to maintain the speed selected by the driver unless a moving obstacle proceeding directly ahead of it in the same travel direction is detected (e.g. following another vehicle ahead at a distance set by Distronic). This means that:**

- **your vehicle can pass another vehicle after you change lanes,**
- **while in a sharp turn or if the vehicle in front is in a sharp turn, Distronic could lose sight of a vehicle traveling in front of it, then your vehicle could accelerate to the previously selected speed.**

**Distronic regulates only the distance between your vehicle and those directly ahead, but does not register stationary objects in the roadway, e.g.:**

- **a stopped vehicle in a traffic jam.**
- **a disabled vehicle.**
- **an oncoming vehicle.**

**The driver must always be on the alert and observe all traffic and intercede with steering and braking inputs as necessary.**

### Important!

When starting the engine, Distronic goes through an initialization and self-test phase.

The most likely cause for a malfunctioning system is caused by a dirty sensor (located behind the hood grille), especially at times of snow and ice or heavy rain. In such a case, Distronic will switch off, and the message “DISTRONIC – CLEAN SENSOR!” appears in the multifunction display.

### Warning!

**Distronic should not be used in snowy or icy road conditions.**

The following are some sample situations which may influence the functions of Distronic.

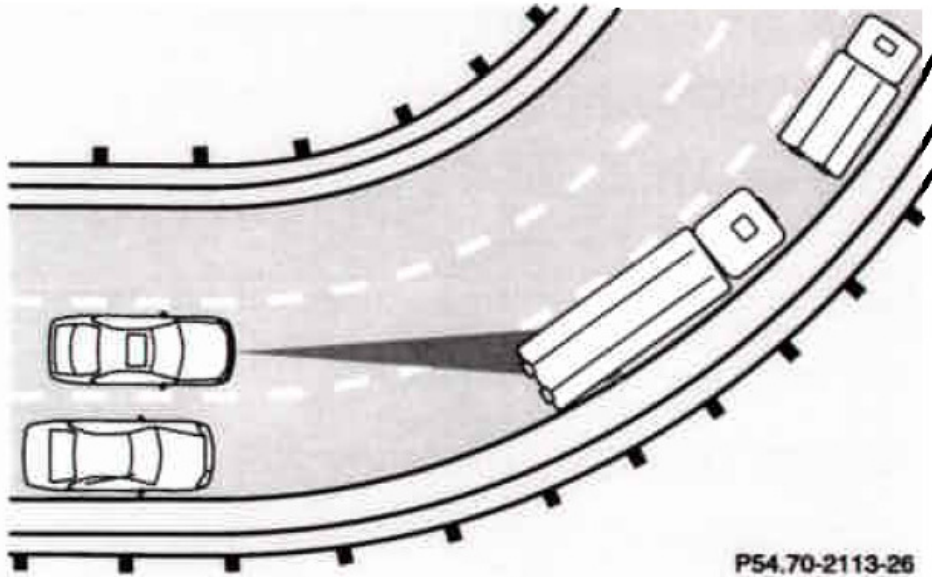

Traveling through turns or bends in the roadway may result in Distronic detecting a moving vehicle traveling in front but not in your lane of travel, causing your vehicle to brake late or unexpectedly. You must be prepared to intercede with accelerator or brake application as necessary.

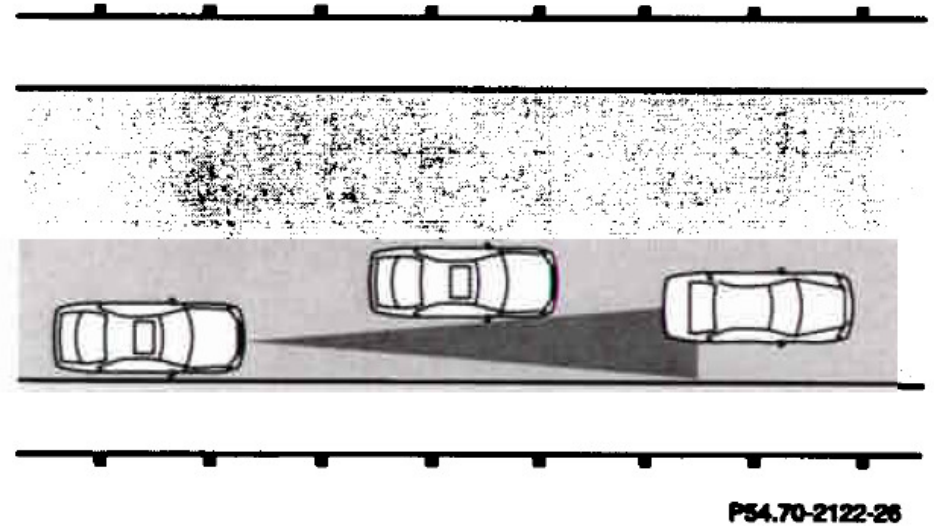

The Distronic system's detection zone is relatively narrow at the start and becomes broader as it senses further from the vehicle. Thus, Distronic may not recognize another vehicle coming into your path close to the front of your vehicle. You must be prepared to intercede with braking or steering as necessary. A vehicle not traveling directly in front of you could cause detection problems, the actual distance to that vehicle really being much shorter.



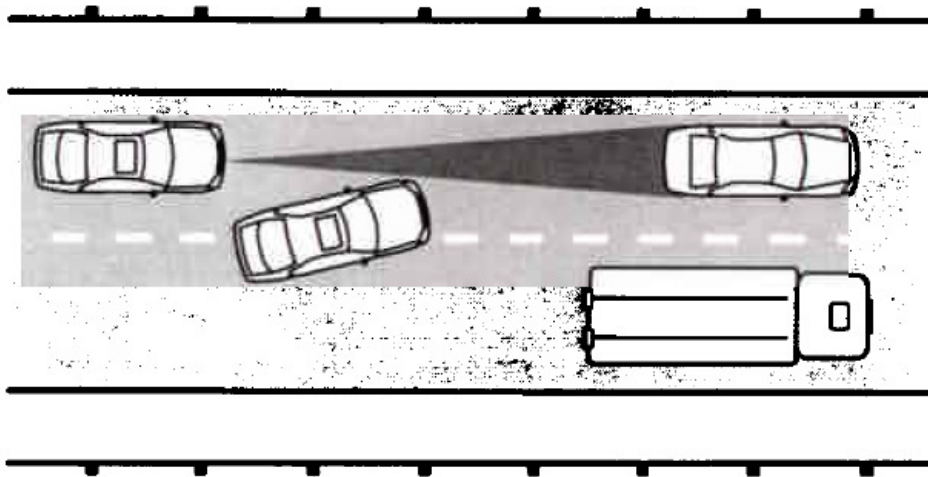

P54.70-2123-26

A vehicle changing lanes at close range is only recognized when entering the area scanned by Distronic. You must apply the service brakes to gain sufficient distance to the vehicle ahead.

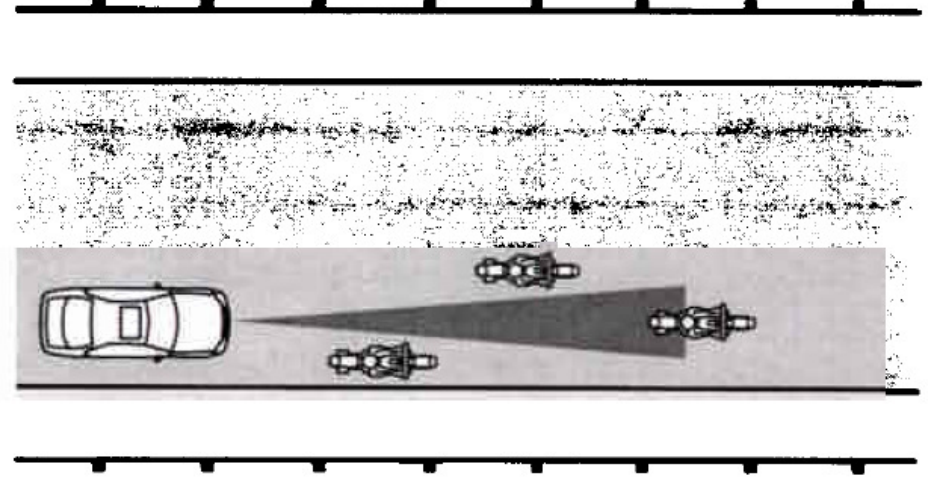

P54.70-2124-26

A narrow vehicle (e.g. a motorcycle) is only recognized when entering the area scanned by Distronic. You must apply the service brakes to gain sufficient distance to the vehicle ahead.

## Distance notification function

Even if DISTRONIC is deactivated, the distance to the vehicle ahead continues to be measured, for multifunction display.

The DISTRONIC lamp in the speedometer dial illuminates to advise the driver of a situation which under normal braking conditions and dry surfaces should have been addressed by the driver.

The distance notification function can be activated separately. It operates when driving at speeds above approx. 25 mph (Canada: 30 km/h).

When recognizing a stationary obstacle or a slower vehicle moving in the vehicle's path and the danger of a collision exists, the distance warning lamp in the speedometer dial lights up and simultaneously a continuous warning sounds.

Note:

**Model CL 55 AMG only:**  
Distance notification function is deactivated if the vehicle speed exceeds approximately 160 mph (260 km/h).

## Important!

With the DISTRONIC switched off, only the distance notification function operates, meaning the vehicle does not slow down.

## Warning!

**If the distance warning lamp in the speedometer dial lights up while driving and a continuous warning sounds, immediate attention on the part of the driver is required.**

**As required by the traffic situation, apply the service brakes and navigate around a possible obstacle. However, do not drive by relying on the distance notification function as that will result in an emergency braking application which, especially depending on road surface conditions and driver reaction, will not always be able to avoid a collision.**

## Important!

Complex driving situations are not always fully recognized by DISTRONIC, which could result in wrong or missing distance warnings.

## Distronic settings



- 1 Switch – for distance notification function
- 2 Thumbwheel – for setting distance

Distronic provides a safe following distance range to the vehicle in front. The medium setting is noticeable by a detent in the center position of the thumbwheel (2).  
If you want to:

- Increase distance – turn thumbwheel (2) towards .

- Decrease distance – turn thumbwheel (2) towards .

### Warning!

It is up to the driver to exercise discretion to select the appropriate setting given road conditions, traffic, driver's preferred driving style and applicable laws and driving recommendations for safe following distance.

To switch the distance notification function on or off:

To switch on – press upper half of switch (1).  
The indicator lamp in the switch lights up.

To switch off – press lower half of the switch (1).  
The indicator lamp in the switch goes out.

### Notes:

With the distance notification function activated, you will still be advised by a continuous audible warning if a potential emergency braking circumstance has been detected, even if Distronic has been deactivated.

The last selected notification function mode (on/off) will be stored in memory, even when removing the electronic key from the starter switch.



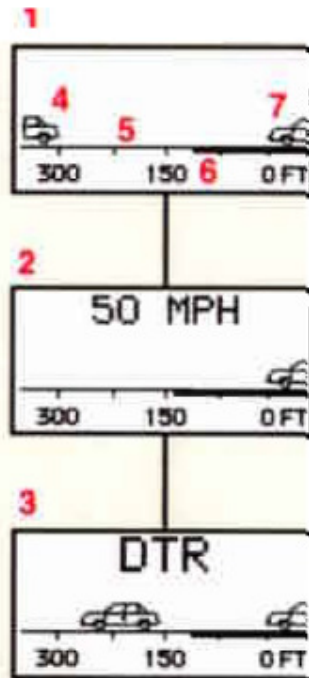

## Multifunction displays



- 1** Distronic is deactivated. The actual distance (5) and the should-be distance (6) to the vehicle ahead (4) are displayed.
- 2** Distronic is activated. The display shows the selected speed for approx. 5 seconds.
- 3** Distronic is activated. The message “DTR OFF” appears for approx. 5 seconds when Distronic is being deactivated.
- 4** Vehicle ahead.  
Only appears if a vehicle is detected ahead.
- 5** Actual distance to vehicle ahead.
- 6** Should-be distance to vehicle ahead (as calculated by Distronic).
- 7** Own vehicle.

To call up Distronic display:

Press button  or  on the multifunction steering wheel repeatedly until the display (1 or 3) appears.

P54.30-3759-27

## Displays in the speedometer dial



When Distronic system is activated, one or two segments around the speed stored in memory light up in the speedometer dial.



If a vehicle is detected ahead, those segments in the speedometer dial light up that indicate the speed range from the speed of the vehicle in front up to the Distronic stored speed.

When the vehicle in front can no longer be detected, only the segments around the stored speed light up. The vehicle is accelerated to the stored speed.

## DISTRONIC (DTR)

### DISTRONIC MALFUNCTION

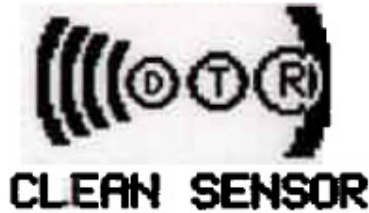

P54.30-2903-21

Line 1	Line 2	C*
DISPLAY DEFECTIVE	VISIT WORKSHOP! <sup>1</sup>	2
DISTRONIC	EXTERNAL MALFUNCTION! <sup>2</sup>	2
DISTRONIC MALFUNCTION	CLEAN SENSOR! <sup>3</sup>	2
DISTRONIC	VISIT WORKSHOP! <sup>4</sup>	2

- 1 The display or the system is malfunctioning.
- 2 Due to the presence of electro-magnetic radiation, the system is presently unavailable.
- 3 DISTRONIC is automatically switched off.  
DISTRONIC sensor in hood grille needs cleaning,
- 4 DISTRONIC is defective.

For operation in the USA and Canada:  
This device complies with Part 15 of the FCC rules and with RSS-210 of Industry Canada.  
Operation is subjected to the following two conditions:  
(1) this device may not cause harmful interference, and  
(2) this device must accept any interference received, including interference that may cause undesired operation.

**WARNING:**  
Changes or modifications made to this equipment not expressly approved by Continental may void the FCC authorization to operate this equipment !



## Cleaning the DISTRONIC system sensor



Use a mild car wash detergent, such as Mercedes-Benz approved Car Shampoo, with plenty of water to clean the sensor (1).

To prevent scratches, never apply strong force and use only a soft, non-scratchy cloth when cleaning the sensor. Do not attempt to wipe dirty sensors with a dry cloth or sponge.

Note:

Restart the engine after cleaning the sensor (1).

## Sensor Overview:

**ARS 2-A** is the basic model of all second generation ARS variants.

**ARS 2-B** The basic model ARS 2-A with following modifications:

- **Electronic:** - Yaw rate sensor ( DC output )
- **Mechanical:** - fixing points

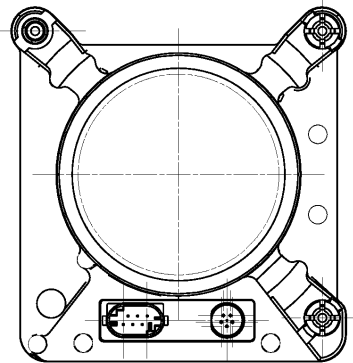

ARS 2-A front view

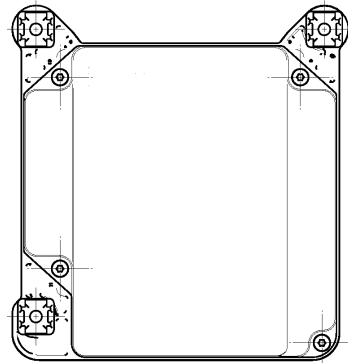

ARS 2-A rear view

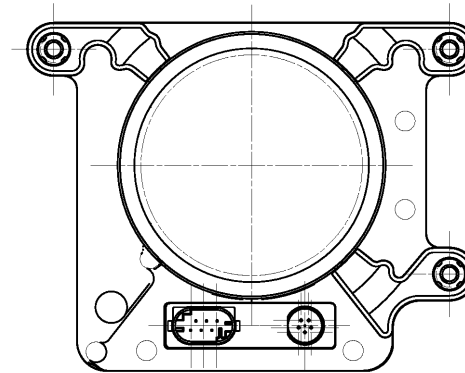

ARS 2-B front view

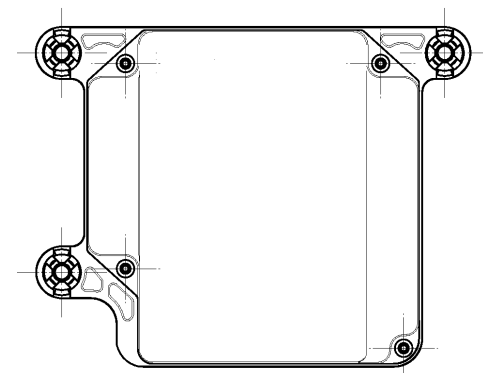

ARS 2-B rear view

**ARS 2-C:** The basic model ARS 2-A with following modifications:

- **Electronic:** none
- **Mechanical:** - polarizing key

ARS 2-C connector pin designation:

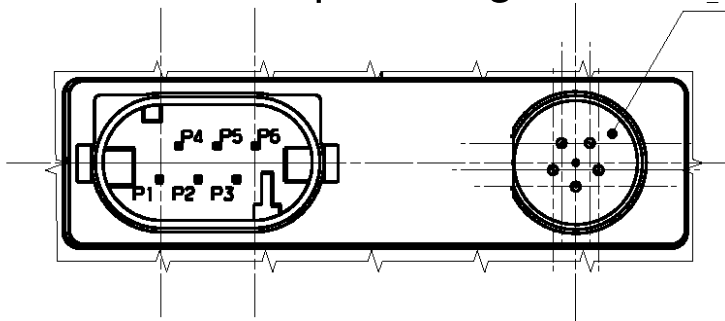

ARS 2-A connector pin designation

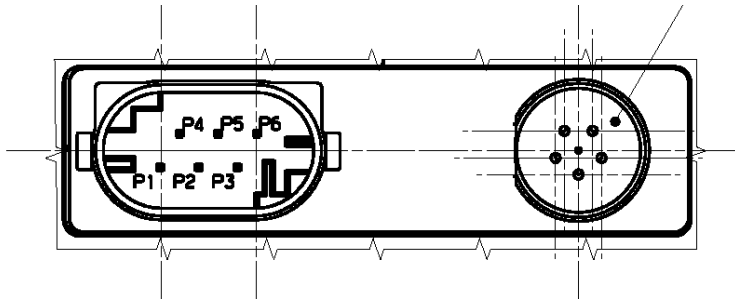

**ARS 3-A** is the basic model of all 3rd generation ARS variants. All variants differ only internally (CAN electronics and power supply)

