



Avaya WLAN 8100

Installation-AP 8120

Release: 1.0

Document Revision: 01.AD

NN47251-302

Avaya WLAN 8100
Release: 1.0
Publication: NN47251-302
Document status:
Document release date: 10 May 2010

© 2010 Avaya Inc.
All Rights Reserved.

Notice

While reasonable efforts have been made to ensure that the information in this document is complete and accurate at the time of printing, Avaya assumes no liability for any errors. Avaya reserves the right to make changes and corrections to the information in this document without the obligation to notify any person or organization of such changes.

Documentation disclaimer

Avaya shall not be responsible for any modifications, additions, or deletions to the original published version of this documentation unless such modifications, additions, or deletions were performed by Avaya. End User agree to indemnify and hold harmless Avaya, Avaya's agents, servants and employees against all claims, lawsuits, demands and judgments arising out of, or in connection with, subsequent modifications, additions or deletions to this documentation, to the extent made by End User.

Link disclaimer

Avaya is not responsible for the contents or reliability of any linked Web sites referenced within this site or documentation(s) provided by Avaya. Avaya is not responsible for the accuracy of any information, statement or content provided on these sites and does not necessarily endorse the products, services, or information described or offered within them. Avaya does not guarantee that these links will work all the time and has no control over the availability of the linked pages.

Warranty

Avaya provides a limited warranty on this product. Refer to your sales agreement to establish the terms of the limited warranty. In addition, Avaya's standard warranty language, as well as information regarding support for this product, while under warranty, is available to Avaya customers and other parties through the Avaya Support Web site: <http://www.avaya.com/support>

Please note that if you acquired the product from an authorized reseller, the warranty is provided to you by said reseller and not by Avaya.

Licenses

THE SOFTWARE LICENSE TERMS AVAILABLE ON THE AVAYA WEBSITE, [HTTP://SUPPORT.AVAYA.COM/M/LICENSEINFO/](http://support.avaya.com/M/LICENSEINFO/) ARE APPLICABLE TO ANYONE WHO DOWNLOADS, USES AND/OR INSTALLS AVAYA SOFTWARE, PURCHASED FROM AVAYA INC., ANY AVAYA AFFILIATE, OR AN AUTHORIZED AVAYA RESELLER (AS APPLICABLE) UNDER A COMMERCIAL AGREEMENT WITH AVAYA OR AN AUTHORIZED AVAYA RESELLER. UNLESS OTHERWISE AGREED TO BY AVAYA IN WRITING, AVAYA DOES NOT EXTEND THIS LICENSE IF THE SOFTWARE WAS OBTAINED FROM ANYONE OTHER THAN AVAYA, AN AVAYA AFFILIATE OR AN AVAYA AUTHORIZED RESELLER, AND AVAYA RESERVES THE RIGHT TO TAKE LEGAL ACTION AGAINST YOU AND ANYONE ELSE USING OR SELLING THE SOFTWARE WITHOUT A LICENSE. BY INSTALLING, DOWNLOADING OR USING THE SOFTWARE, OR AUTHORIZING OTHERS TO DO SO, YOU, ON BEHALF OF YOURSELF AND THE ENTITY FOR WHOM YOU ARE INSTALLING, DOWNLOADING OR USING THE SOFTWARE (HEREINAFTER REFERRED TO INTERCHANGEABLY AS "YOU" AND "END USER"), AGREE TO THESE TERMS AND CONDITIONS AND CREATE A BINDING CONTRACT BETWEEN YOU AND AVAYA INC. OR THE APPLICABLE AVAYA AFFILIATE ("AVAYA").

Copyright

Except where expressly stated otherwise, no use should be made of the Documentation(s) and Product(s) provided by Avaya. All content in this documentation(s) and the product(s) provided by Avaya including the selection, arrangement and design of the content is owned either by Avaya or its licensors and is protected by copyright and other intellectual property laws including the sui generis rights relating to the protection of databases. You may not modify, copy, reproduce, republish, upload, post, transmit or distribute in any way any content, in whole or in part, including any code and software. Unauthorized reproduction, transmission, dissemination, storage, and or use without the express written consent of Avaya can be a criminal, as well as a civil offense under the applicable law.

Third Party Components

Certain software programs or portions thereof included in the Product may contain software distributed under third party agreements ("Third Party Components"), which may contain terms that expand or limit rights to use certain portions of the Product ("Third Party Terms"). Information regarding distributed Linux OS source code (for those Products that have distributed the Linux OS source code), and identifying the copyright holders of the Third Party Components and the Third Party Terms that apply to them is available on the Avaya Support Web site:

<http://support.avaya.com/Copyright>

Trademarks

The trademarks, logos and service marks ("Marks") displayed in this site, the documentation(s) and product(s) provided by Avaya are the registered or unregistered Marks of Avaya, its affiliates, or other third parties. Users are not permitted to use such Marks without prior written consent from Avaya or such third party which may own the Mark. Nothing contained in this site, the documentation(s) and product(s) should be construed as granting, by implication, estoppel, or otherwise, any license or right in and to the Marks without the express written permission of Avaya or the applicable third party. Avaya is a registered trademark of Avaya Inc. All non-Avaya trademarks are the property of their respective owners.

Downloading documents

For the most current versions of documentation, see the Avaya Support. Web site: <http://www.avaya.com/support>

Contact Avaya Support

Avaya provides a telephone number for you to use to report problems or to ask questions about your product. The support telephone number is 1-800-242-2121 in the United States. For additional support telephone numbers, see the Avaya Web site: <http://www.avaya.com/support>

Contents

Installation reference	7
Access Point 8120 overview	7
External hardware features	7
Access Point 8120 front view	8
Access Point 8120 rear view	8
Kensington cable interface	9
Mounting options	9
Status Light-emitting diode (LED)	10
Installation preparation	11
Unpacking the access point	11
Cabling requirements	11
Management software	13
Network plans and work orders	13
Wireless Controller 8180 recommendation	13
Wall installation recommendations	13
Radio safety advisories	13
Radio frequency advisories	14
Additional radio safety advisories	14
Access Point 8120 installation	15
Mounting a wireless LAN access point on a wall	15
Installing an Access Point with a ceiling grid adaptor	17
Installation tools and utilities	21
Installation hardware and tools	21
Access Point Troubleshooting	23
Appendix	25
IEEE 802.11a/b/g Channel Designations:	25
2400 to 2483.5 MHz band	25
Legend	25
5.15 to 5.35 GHz bands	25
5.470 to 5.725 GHz bands	25
5.725 to 5.85 GHz bands	26

Legend 26

Common antenna terminology

27

27

Installation reference

Access Point 8120 overview

The Avaya Access Point 8120 (AP 8120) is the wireless access portion of the Avaya WLAN 8100 Series solution. The AP 8120 provides 802.11a+n b/g+n wireless connectivity through six dual-band 2.4/5.0 GHz antennas; three dedicated to 2.4 GHz use and three dedicated to 5.0 GHz . The AP 8120 is designed for use with the Wireless Controller 8180 (WC 8180). The WC 8180 coordinates and load balances domains of access points in the network.

The AP 8120 communicates with the WC 8180 using a standard Category 5 (CAT-5) or higher 10/100/1000Mbps twisted pair Ethernet cable. The AP 8120 is intended for indoor installations only. It does not accept the connection of external antennas.

The AP 8120 requires hardware installation only. Access point configuration is performed on the WC 8180 after installation and connection to the network.



WARNING

The installation of the Access Point 8120 should only be performed by qualified service personnel. Read and follow all warning notices and instructions on the product or included in the documentation.

External hardware features

This section contains information on the external hardware features of the Access Point 8120. This section contains the following topics:

- ["Access Point 8120 front view" \(page 8\)](#)
- ["Access Point 8120 rear view" \(page 8\)](#)
- ["Kensington cable interface" \(page 9\)](#)
- ["Mounting options" \(page 9\)](#)
- ["Status Light-emitting diode \(LED\)" \(page 10\)](#)

Access Point 8120 front view

The following diagram illustrates the front view of the Access Point 8120.

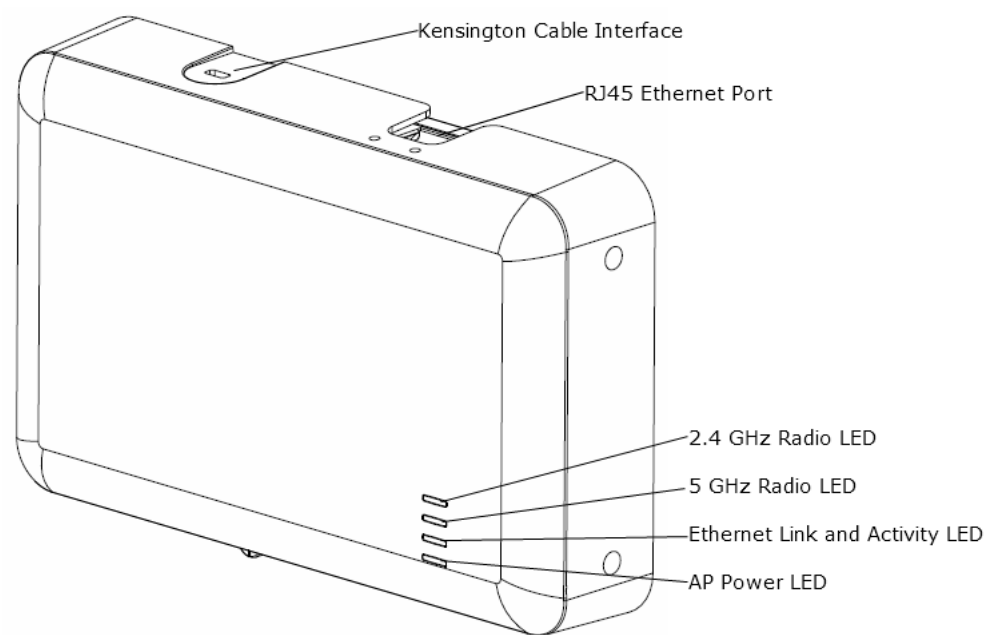

Access Point 8120 rear view

The following diagram illustrates the rear view of the Access Point 8120.

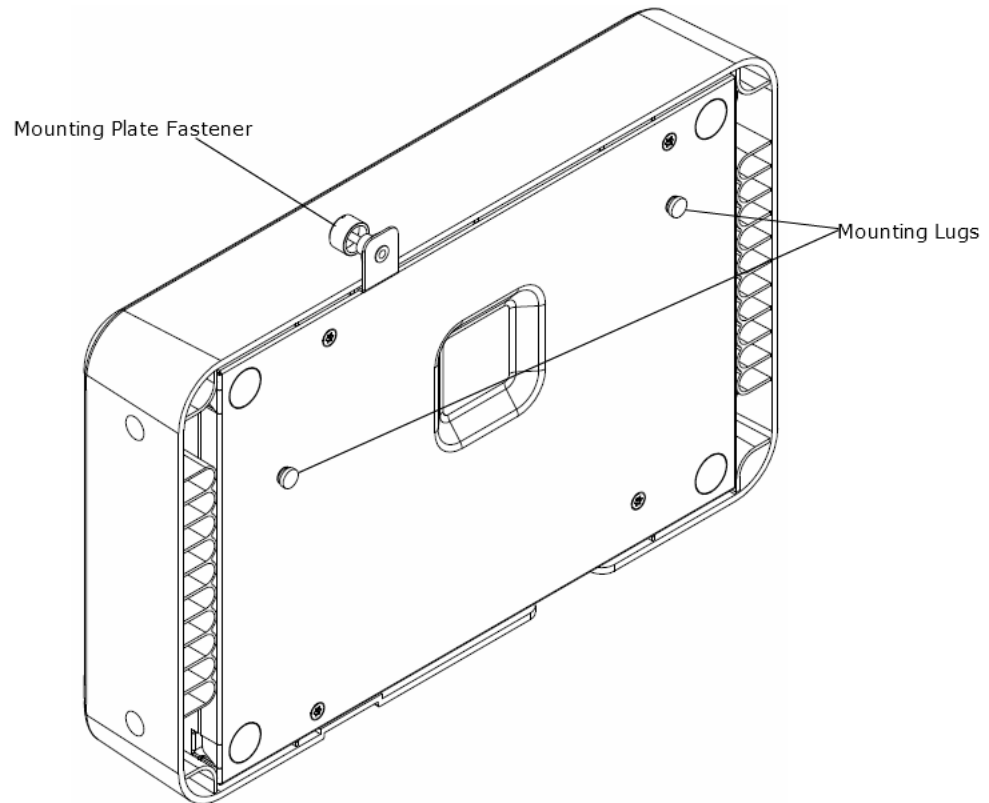

Kensington cable interface

The Access Point 8120 has an interface for attaching a Kensington security cable. The cable is not included with the access point.

Mounting options

The access point can be mounted on the following types of surfaces:

- Suspended T-bar ceiling
- Junction box
- Solid surface wall or ceiling

Attention: The solid surface mounting option requires CAT-5 cable that does not have strain relief. Other mounting options can use CAT-5 cable with or without strain relief.

Status Light-emitting diode (LED)

The AP 8120 has four LEDs that provide status information on the device. Refer to "[Access Point 8120 front view](#)" (page 8) for the location of the LEDs. The following table describes the different states of the LEDs.

LED	Appearance	Meaning
2.4 GHz	Blinking green	Associated client is sending or receiving traffic.
	Blinking amber	Non-associated client is sending and receiving traffic.
	Alternating green and amber	The radio is unable to transmit due to excessive radio interference or the radio has failed.
	Unlit	The radio is disabled or currently not experiencing any traffic activity.
5 GHz	Blinking green	Associated client is sending or receiving traffic.
	Blinking amber	Non-associated client is sending and receiving traffic.
	Alternating green and amber	The radio is unable to transmit due to excessive radio interference or the radio has failed.
	Unlit	The radio is disabled or currently not experiencing any traffic activity.
Ethernet Link and Activity	Blinking green	The access point is engaged in normal network activities.
	Blinking amber	The access point is unable to communicate with the network.
	Unlit	The access point does not have network connectivity.
AP Power	Solid green	The access point is receiving power.
	Unlit	The access point is not receiving power.

Installation preparation

Unpacking the access point

The shipping carton for an AP contains the following items:

- one AP
- mounting kit
 - one universal mounting bracket (attached to the AP)
 - one dual size (15/16 and 5/8 inch) T-bar clamp
 - one mounting bracket that attaches to the T-bar clamp and AP
 - four adhesive rubber feet
- *Avaya WLAN 8100 - Regulatory Information - AP 8120* document

Verify that the items removed from the shipping carton correspond to the provided list. If an item is missing or damaged, contact Avaya.

Cabling requirements

The AP 8120 access point has one RJ-45 port. This port provides a 10/100/1000BASE-TX Ethernet connection to a Wireless Controller 8180. This port is used to indirectly connect an access point to a WC 8180 through an intermediate Layer 2 or Layer 3 network.

The access point can receive power and data through the RJ-45 port. Use a Category 5 (CAT-5) cable with straight-through signaling and standard RJ-45 connectors to connect to a network device. The AP 8120 supports 802.3af. An Avaya-approved power injectors must be used to provide the access point with power over the Ethernet cable. The WC 8180 has no PoE capabilities.

The Ethernet port on the access point cannot accept a CAT-5 cable that has an uneven sheath as shown below. The RJ-45 connector on the cable will not seat properly in the receptacle on the access point. Use a CAT-5 cable with an even sheath instead.

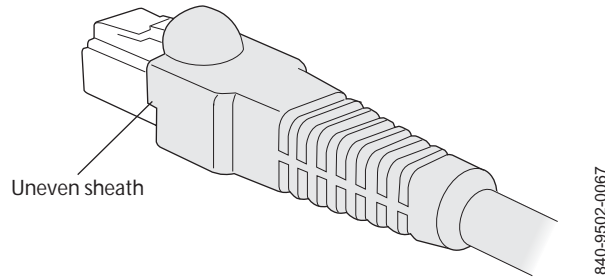

You must operate the access point with a CAT-5 Ethernet cable installed on the Ethernet port to ensure compliance with the Class B emissions standards. Failure to comply with this installation requirement can cause the device to operate in excess of the allowable emissions limits.

Attention: The AP 8120 access point is intended for indoor use only. Do not install the device or operate it outdoors.

Attention: To reduce the possibility of connection interference caused by dust, clean the CAT-5 connector pins before inserting a cable into an AP.

The following table lists the pin signals for the 10/100/1000 Ethernet straight-through wiring. Pins 4, 5, 7, and 8 are used when Avaya Power over Ethernet (PoE) is enabled on the port.

Wireless Controller 8180	
Pin	Function
1	Bidirectional pair +A
2	Bidirectional pair -A
3	Bidirectional pair +B
4	Bidirectional pair +C
5	Bidirectional pair -C
6	Bidirectional pair -B
7	Bidirectional pair +D
8	Bidirectional pair -D

Management software

If you are using the WLAN Management Software (WMS) to plan your Avaya Mobility System installation, you can create and verify a network plan for the entire Avaya network installation and generate an AP work order, before installing any access points.

Network plans and work orders

A network plan and the AP work orders provide the following information about AP installation and configuration:

- number of APs required for adequate WLAN capacity in each coverage area
- detailed installation location for each AP
- settings for all APs in the WLAN

For information about installing WLAN Management Software, creating and verifying a network plan, and generating an AP work order, see the *Avaya WLAN 8100 - Planning and Engineering* document.

Wireless Controller 8180 recommendation

Avaya recommends that you install and configure the Wireless Controller 8180 before installing an AP. If the switch is already installed and configured for the access points, you can immediately verify the cable connection when you plug the cable into the RJ-45 port on the AP.



CAUTION

AP 8120 access points are designed to receive power only from an 802.3af-compliant source or an Avaya-approved power injector. Connecting an AP to a Power over Ethernet (PoE) device that is not approved by Avaya can damage the equipment.

For more information about connecting an AP to a WC 8180 port, see *Connecting to a Wireless Controller 8180*.

Wall installation recommendations

If you plan to install an AP on a partial wall or other vertical surface, orient the top of the access point (the side with the LEDs) toward the intended coverage area. The radio antennas transmit through the top of the access point but not through the bottom (where the bracket is located).

Radio safety advisories

When you enable the AP radios as part of a configuration, the radios can receive and transmit radio frequency energy as soon as you connect the AP to the WC 8180, either directly or through the network.

Radio frequency advisories

Federal Communications Commission (FCC) Docket 96-8 for Spread Spectrum Transmitters specifies a safety standard for human exposure to radio frequency electromagnetic energy emitted by FCC-certified equipment. The Avaya Access Point 8120 product meets the uncontrolled environmental limits found in OET-65 and ANSI C95.1-1991, if proper installation procedures are followed. To ensure compliance with these exposure requirements, you must install this device in such a manner as to maintain a minimum of 20 cm separation distance between the radiating elements and all persons.

Additional radio safety advisories

**WARNING**

Install this device in such a manner as to maintain a minimum of 20 cm (7.9 inches) separation distance between the radiating elements and all persons. This safety warning conforms with FCC radio frequency exposure limits.

**WARNING**

Do not operate the AP near unshielded blasting caps or in an otherwise explosive environment unless the device has been modified for such use by qualified personnel.

**WARNING**

Do not touch or move the AP when the antennas are transmitting or receiving.

**WARNING**

Before using a wireless device in a hazardous location, consult the local codes, national codes, and safety directors of the location for usage constraints.

Access Point 8120 installation

This section contains procedures for the installation of the Access Point 8120.

Mounting a wireless LAN access point on a wall

The mounting bracket is designed to use wall anchors with threaded section diameters ranging between 3.5mm and 4.5mm. If wall anchors have threaded diameters greater than 3.5mm, only the two mounting holes marked 'A' may be used. If wall anchors have threaded diameters of less than 3.5mm, the holes marked 'A' and the holes marked 'B' may be used. All wall anchors must have a head diameter of less than 10mm or the wall mounting bracket cannot be installed over them.

Perform the following procedure to mount a wireless LAN access point on a wall:

Procedure steps

Step	Action
1	Locate the appropriate position of the wall anchors. The wall anchors should be 95mm apart horizontally and 80mm apart vertically.

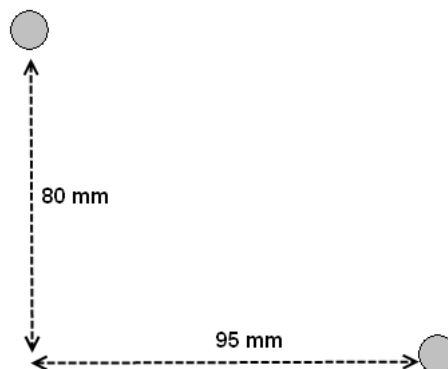

The wall bracket is designed to use a minimum of 2 anchors and a maximum of 4.

- 2 Install the screws into the wall anchors but do not seat them fully, leave at least a 2mm gap between the screw head and the wall.
- 3 Slip the wall bracket over the heads of the screws and slide the bracket to the right as viewed facing the wall.

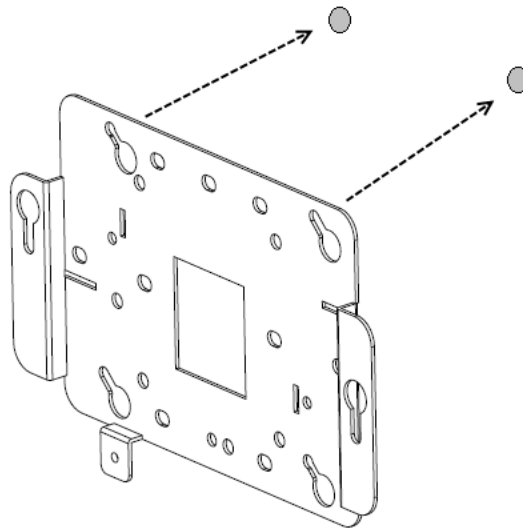

- 4 Tighten the screws to secure the wall mounting bracket tightly against the wall.
- 5 Align the mounting tabs on the bottom of the access point sheet metal enclosure with the vertically oriented keyhole slots in the mounting bracket.

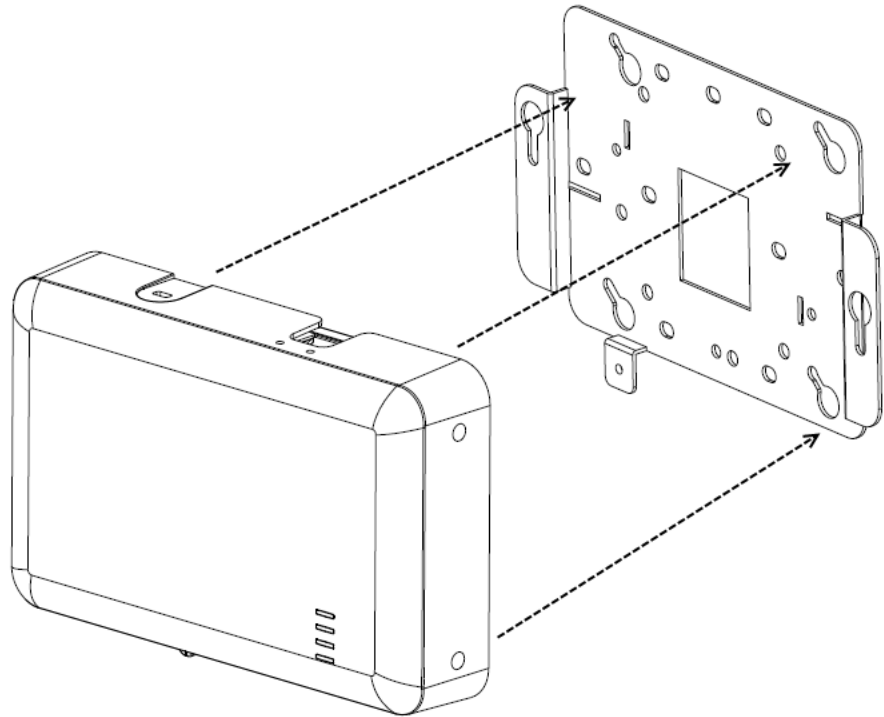

- 6 Allow the access point to slide down the keyhole slots, making sure the access point mounting tabs are seated at the bottom of the slot.
- 7 Secure the access point to the wall mounting bracket and tighten the thumbscrews.
- 8 Verify that the access point is secured to both the bracket and to the wall.

--End--

Installing an Access Point with a ceiling grid adaptor

The ceiling grid adaptor comes with two interlocking bracket parts. The larger bracket includes keyhole shaped slots which mate with tabs on the under surface of the AP and a threaded hole that mates with the captive thumbscrew on the AP. The smaller bracket also includes a captive fastener and it can be oriented with respect to the larger bracket in two different ways corresponding to narrow or wide ceiling grids.

Perform the following procedure to install the access point with a ceiling grid adaptor:

Procedure steps

Step	Action
1	Secure a safe work environment. Obtain a ladder that allows easy access to the ceiling grid system.
2	Identify an appropriate location on the ceiling grid where the ceiling T-bars are safely accessible and where the ceiling tiles can be temporarily elevated and cleared away from the work area. The adaptor bracket assembly is intended for use with the thin section grid runners, not the thicker section runners used to cross large spans. To provide access for hands and tools, use a pair of pencils or sticks to hold up the ceiling tiles out of the grid. Doing this provides easy access for securing the bracket to the grid.
3	Mount the larger bracket to the grid. While installing, pay attention to the width of the grid strip in order to ascertain the appropriate orientation for the smaller bracket which is installed next.

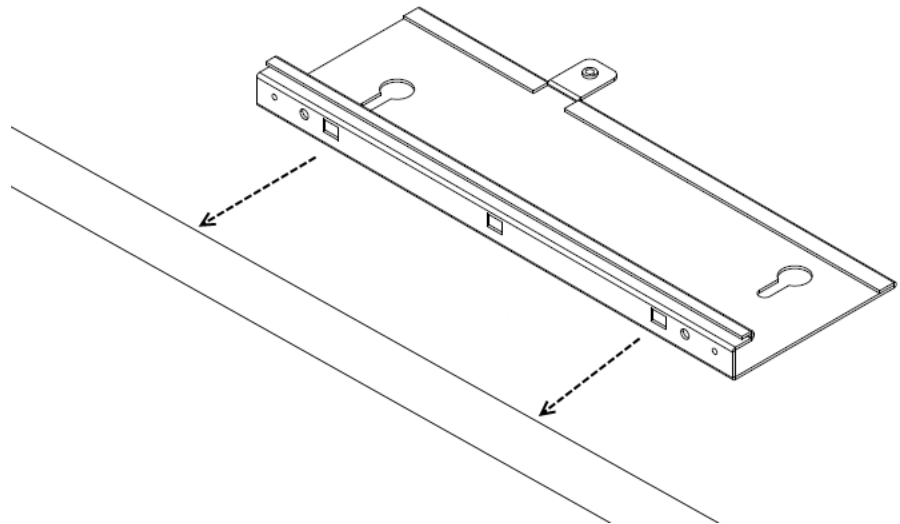

- 4 Mount the interlocking small bracket to the large bracket and clamp the two pieces together on the grid. The smaller bracket has tabs formed into it which engage slots in the larger tab. This allows the two parts to slide together and lock to one another. When this is done, the two brackets effectively clamp themselves around the ceiling grid. When the two halves of the bracket are correctly slid together, the captive fastener in the small bracket should engage threads provided in the larger bracket. Use a screwdriver to screw down the captive fastener. Securing the two brackets in this manner is essential to prevent them from disengaging from one another. Tighten the captive fastener screw securely.

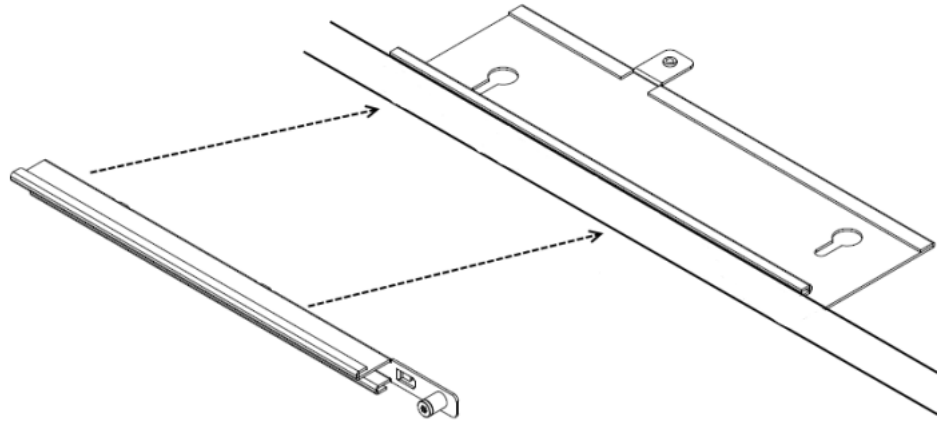

- 5 Attach the access point to the bracket. Align the access point securing tabs with the keyhole slots in the ceiling grid bracket and carefully slide the access point onto the ceiling grid bracket assembly. If the access point and the bracket assembly are correctly engaged, it should be possible to engage the access points captive thumbscrew into the threaded tab provided on the ceiling grid bracket.

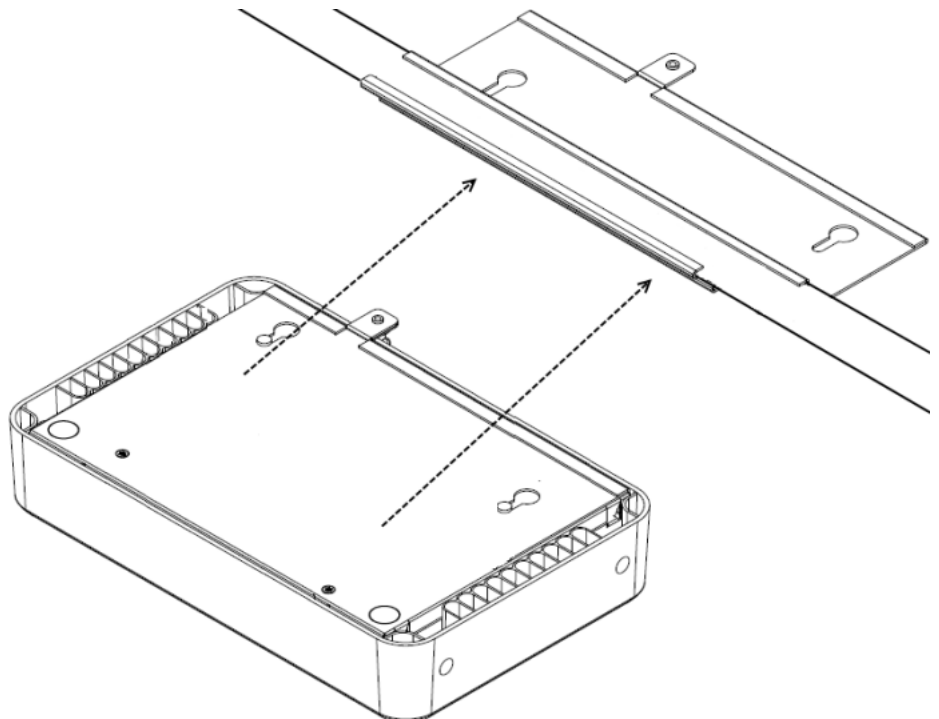

- 6 Make electrical connections and return ceiling tiles.

--End--

Installation tools and utilities

Installation hardware and tools

The following table lists the mounting hardware and tools required for each type of installation.

Mounting option	Required hardware and tools	Included with the product
Ceiling installations	Universal mounting bracket	Yes
	T-bar clamp	Yes
	Box cutter	No
	Small screwdriver (3-mm or 1/8-inch)	No
	Junction box	No
Wall mounting	Universal mounting bracket	Yes
	Small screwdriver (3-mm or 1/8-inch)	No
	#2 Phillips-head screwdriver	No

Access Point Troubleshooting

After you insert the CAT-5 cable into an AP's port connector and enable PoE on the cable, observe the device's health or link LED to determine the status of the connection with the WC 8180.

- If the LED is green and is glowing steadily, the AP was booted successfully by the WC 8180 and is ready for operation.
- If the LED is not steadily glowing green, see the following table.

For descriptions of all the LEDs, see ["Status Light-emitting diode \(LED\)" \(page 10\)](#).

Health or LINK LED appearance	Diagnosis	Remedy
Not solid green	AP radio needs to be enabled.	Enable at least one of the radios. If the LED is still not solid green, try the remedy listed in this table based on the LEDs appearance.
Unlit	AP is not receiving power.	Check the CAT-5 cable connections. Do the following: <ul style="list-style-type: none"> • Confirm AP health using the WMS or WC 8180 CLI. • Verify that an Avaya-approved PoE source is supplying power to the AP.

Health or LINK LED appearance	Diagnosis	Remedy
Slowly alternating green and amber	AP is starting with an image received from a WC 8180.	Wait a few seconds for the boot process to complete. If this LED appearance persists, enable a radio or place a radio in sentry mode.
Solid amber	AP is waiting to receive boot instructions and a configuration file from a WC 8180.	Wait a few seconds for the boot process to begin. If the LED remains amber, try the remedies for the other health LED appearances. If the LED still remains amber, ensure the AP is securely connected to its PoE source and to the network.

Appendix

IEEE 802.11a/b/g Channel Designations:

2400 to 2483.5 MHz band

IEEE Mode	11b/g	11b/g	11b/g	11b/g	11b/g	11b/g	11b/g
Channel number	1	2	3	4	5	6	7
Frequency (GHz)	2.412	2.417	2.422	2.427	2.432	2.437	2.442
IEEE mode	11b/g	11b/g	11b/g	11b/g	11b/g	11b/g	11b/g
Channel number	8	9	10	11	12	13	14
Frequency (GHz)	2.447	2.452	2.457	2.456	2.467	2.472	2.484

Legend

- 11: Channels 1 through 11, inclusive (U.S. based)
- 13: Channels 1 through 13, inclusive (EU based)
- 14: Channels 1 through 14, inclusive (Japan based)

5.15 to 5.35 GHz bands

IEEE mode	11a	11a	11a	11a	11a	11a	11a	11a
Channel number	36	40	44	48	52	56	60	64
Frequency (GHz)	5.180	5.200	5.220	5.240	5.260	5.280	5.300	5.320

5.470 to 5.725 GHz bands

IEEE mode	11a	11a	11a	11a	11a	11a	11a	11a
Channel Number	100	104	108	112	116	120	124	128

Frequency (GHz)	5.500	5.520	5.540	5.560	5.580	5.600	5.620	5.640
IEEE mode	11a	11a	11a					
Channel number	132	136	140					
Frequency (GHz)	5.660	5.680	5.700					

5.725 to 5.85 GHz bands

IEEE mode	11a	11a	11a	11a	11a
Channel number	149	153	157	161	165
Frequency (GHz)	5.745	5.765	5.785	5.805	8.825

Legend

- 1: Channels 36, 40, 44, 48
- 2: Channels 52, 56, 60, 64
- 4: Channels 100, 104, 108, 112, 116, 120, 124, 128, 132, 136, 140
- 7: Channels 149, 153, 157, 161, 165
- All combinations, such as 1, 2, 7 represent all of the channels listed in the separate sections of 1, 2 and 7: 36, 40, 44, 48, 52, 56, 60, 64, 149, 153, 157, 161, 165

Common antenna terminology

The following glossary includes basic antenna terminology that can help in the selection and recommendation of a particular antenna.

Omnidirectional (Omni)

Refers to the antenna coverage pattern. An omnidirectional antenna creates a uniform coverage pattern. Most omnidirectional antennas are weakest directly above and directly below their endpoints — this characteristic creates the familiar dual-lobe pattern shown on the E-plane graphs. Nulls are typically related to the orientation of the dipole/monopole antenna relative to the horizontal or vertical planes. The lobes grow and shrink depending upon the ground plane effects and cancellation/addition of the radiating signal. Omnidirectional antennas are suitable for most general deployments.

Directional

Refers to the antenna coverage pattern. A directional antenna focuses its lobe or radiated energy in a particular direction. In general, as the gain of a directional antenna increases, the radiating beamwidth or lobe decreases. This design increases the transmitted power and communication distance in a specific direction at the expense of uniform coverage, as compared to an omnidirectional antenna. You must aim a directional antenna at the intended coverage zone.

Gain

Expressed in dBi, indicates the relative increase in radiated power over an isotropic point radiating source with a reference gain of 1.0.

Each 3 dB increment in power effectively doubles the radiated energy. For example, an antenna with a gain of 9 dBi increases the transmit power 8 times more than an isotropic point radiating source. For example

$$12.5 \text{ mW} = 11 \text{ dBm}$$

$$11 \text{ dBm} + 9\text{dBi} = 20 \text{ dBm}$$

$$20 \text{ dBm} = 100 \text{ mW}$$

$$100\text{mw}/12.5 \text{ mW} = 8 \text{ times more power}$$

E-Plane graph

The elevation plane graph shows the radiated antenna coverage pattern as a vertical cross section — as if looking directly at the antenna from the side.

H-Plane graph

The horizontal plane graph shows the radiated antenna coverage pattern as a horizontal cross section — as if looking directly at the antenna from above.