



Avaya WLAN 8100

Regulatory Information - AP 8120

Release: 1.0

Document Revision: 01.02

NN47251-104

325887-A

Avaya WLAN 8100
Release: 1.0
Publication: NN47251-104
Document release date: 18 May 2010

© 2010 Avaya Inc.
All Rights Reserved.

Notice

While reasonable efforts have been made to ensure that the information in this document is complete and accurate at the time of printing, Avaya assumes no liability for any errors. Avaya reserves the right to make changes and corrections to the information in this document without the obligation to notify any person or organization of such changes.

Documentation disclaimer

Avaya shall not be responsible for any modifications, additions, or deletions to the original published version of this documentation unless such modifications, additions, or deletions were performed by Avaya. End User agree to indemnify and hold harmless Avaya, Avaya's agents, servants and employees against all claims, lawsuits, demands and judgments arising out of, or in connection with, subsequent modifications, additions or deletions to this documentation, to the extent made by End User.

Link disclaimer

Avaya is not responsible for the contents or reliability of any linked Web sites referenced within this site or documentation(s) provided by Avaya. Avaya is not responsible for the accuracy of any information, statement or content provided on these sites and does not necessarily endorse the products, services, or information described or offered within them. Avaya does not guarantee that these links will work all the time and has no control over the availability of the linked pages.

Warranty

Avaya provides a limited warranty on this product. Refer to your sales agreement to establish the terms of the limited warranty. In addition, Avaya's standard warranty language, as well as information regarding support for this product, while under warranty, is available to Avaya customers and other parties through the Avaya Support Web site: <http://www.avaya.com/support>

Please note that if you acquired the product from an authorized reseller, the warranty is provided to you by said reseller and not by Avaya.

Licenses

THE SOFTWARE LICENSE TERMS AVAILABLE ON THE AVAYA WEBSITE, [HTTP://SUPPORT.AVAYA.COM/M/LICENSEINFO/](http://support.avaya.com/M/LICENSEINFO/) ARE APPLICABLE TO ANYONE WHO DOWNLOADS, USES AND/OR INSTALLS AVAYA SOFTWARE, PURCHASED FROM AVAYA INC., ANY AVAYA AFFILIATE, OR AN AUTHORIZED AVAYA RESELLER (AS APPLICABLE) UNDER A COMMERCIAL AGREEMENT WITH AVAYA OR AN AUTHORIZED AVAYA RESELLER. UNLESS OTHERWISE AGREED TO BY AVAYA IN WRITING, AVAYA DOES NOT EXTEND THIS LICENSE IF THE SOFTWARE WAS OBTAINED FROM ANYONE OTHER THAN AVAYA, AN AVAYA AFFILIATE OR AN AVAYA AUTHORIZED RESELLER, AND AVAYA RESERVES THE RIGHT TO TAKE LEGAL ACTION AGAINST YOU AND ANYONE ELSE USING OR SELLING THE SOFTWARE WITHOUT A LICENSE. BY INSTALLING, DOWNLOADING OR USING THE SOFTWARE, OR AUTHORIZING OTHERS TO DO SO, YOU, ON BEHALF OF YOURSELF AND THE ENTITY FOR WHOM YOU ARE INSTALLING, DOWNLOADING OR USING THE SOFTWARE (HEREINAFTER REFERRED TO INTERCHANGEABLY AS "YOU" AND "END USER"), AGREE TO THESE TERMS AND CONDITIONS AND CREATE A BINDING CONTRACT BETWEEN YOU AND AVAYA INC. OR THE APPLICABLE AVAYA AFFILIATE ("AVAYA").

Copyright

Except where expressly stated otherwise, no use should be made of the Documentation(s) and Product(s) provided by Avaya. All content in this documentation(s) and the product(s) provided by Avaya including the selection, arrangement and design of the content is owned either by Avaya or its licensors and is protected by copyright and other intellectual property laws including the sui generis rights relating to the protection of databases. You may not modify, copy, reproduce, republish, upload, post, transmit or distribute in any way any content, in whole or in part, including any code and software. Unauthorized reproduction, transmission, dissemination, storage, and or use without the express written consent of Avaya can be a criminal, as well as a civil offense under the applicable law.

Third Party Components

Certain software programs or portions thereof included in the Product may contain software distributed under third party agreements ("Third Party Components"), which may contain terms that expand or limit rights to use certain portions of the Product ("Third Party Terms"). Information regarding distributed Linux OS source code (for those Products that have distributed the Linux OS source code), and identifying the copyright holders of the Third Party Components and the Third Party Terms that apply to them is available on the Avaya Support Web site:

<http://support.avaya.com/Copyright>

Trademarks

The trademarks, logos and service marks ("Marks") displayed in this site, the documentation(s) and product(s) provided by Avaya are the registered or unregistered Marks of Avaya, its affiliates, or other third parties. Users are not permitted to use such Marks without prior written consent from Avaya or such third party which may own the Mark. Nothing contained in this site, the documentation(s) and product(s) should be construed as granting, by implication, estoppel, or otherwise, any license or right in and to the Marks without the express written permission of Avaya or the applicable third party. Avaya is a registered trademark of Avaya Inc. All non-Avaya trademarks are the property of their respective owners.

Downloading documents

For the most current versions of documentation, see the Avaya Support. Web site: <http://www.avaya.com/support>

Contact Avaya Support

Avaya provides a telephone number for you to use to report problems or to ask questions about your product. The support telephone number is 1-800-242-2121 in the United States. For additional support telephone numbers, see the Avaya Web site: <http://www.avaya.com/support>

Contents

Regulatory Compliance Statements	7
Federal Communications Commission (FCC) Compliance Notices	7
Class B Interference Statement	7
FCC Caution:	8
RF Radiation Exposure and Hazard Statement	8
Non-Modification Statement	8
Deployment Statement	8
Dynamic Frequency Selection (DFS) in the 5.0 GHz UNII bands	8
Canadian IC Statements	9
European Union and European Free Trade Association (EFTA) Regulatory Compliance	9
Declaration of Conformity	10
European Community Declaration of Conformity	11
Countries of Operation and Restrictions of Use in the European Community	13
Operation Using the 2.400 to 2.4835 GHz Channels in the European Community	13
Operation Using the 5.15 to 5.25 GHz, 5.25 to 5.35 GHz, and 5.470 to 5.725 GHz Channels in the European Community	13
Dynamic Frequency Selection (DFS)	14
Transmit Power Control	14
Antenna Statement	15
English	17
Cable requirements	17
Mounting a wireless LAN access point on a wall	17
Installing an Access Point with a ceiling grid adaptor	19
Safety Messages	22
Deutsch	23
Kabelanschlüsse	23
Wandmontage eines Wireless LAN Access Points	23
Deckenmontage eines Access Points (Rasterdecke)	25
Sicherheitshinweise	28
Español	31
Requisitos del cable	31

Montaje en la pared de un punto de acceso inalámbrico para redes LAN	31
Instalación de un punto de acceso con un adaptador para estructuras de techos desmontables	34
Advertencias de seguridad	36

Français **39**

Configuration requise pour les câbles	39
Montage mural du point accès WLAN	39
Installation du point accès avec un adaptateur pour grille de plafond	41
Messages de sécurité	44

Português do Brasil **47**

Requisitos de cabo	47
Instalando um ponto de acesso LAN sem fio em uma parede	47
Instalando um ponto de acesso com um adaptador de grade de teto	49
Mensagens de segurança	52

Regulatory Compliance Statements

The Avaya WLAN 8100 product line consists of the following models:

- AP 8120-R00
- AP 8120-R06

This section contains regulatory compliance statements for these units.

Federal Communications Commission (FCC) Compliance Notices

This section includes the following FCC statements for the AP 8120-R00 access point:

- FCC ID:
- Class B Interference Statement
- RF Radiation Exposure and Hazard Warning
- Non-Modification Statement
- Deployment Statement

Class B Interference Statement

This equipment has been tested and found to comply with the limits for a Class B digital device, pursuant to Part 15 of the FCC Rules. These limits are designed to provide reasonable protection against harmful interference in a residential installation. This equipment generates, uses, and can radiate radio frequency energy and, if not installed and used in accordance with the instructions, may cause harmful interference to radio communications. However, there is no guarantee that interference will not occur in a particular installation. If this equipment does cause harmful interference to radio or television reception, which can be determined by turning the equipment off and on, the user is encouraged to try to correct the interference by one or more of the following measures:

- Reorient or relocate the receiving antenna.
- Increase the separation between the equipment and receiver.

- Connect the equipment into an outlet on a circuit different from that to which the receiver is connected.
- Consult the dealer or an experienced radio/TV technician for help.

FCC Caution:

This device complies with Part 15 of the FCC Rules. Operation is subject to the following two conditions: (1) This device may not cause harmful interference, and (2) this device must accept any interference received, including interference that may cause undesired operation.

RF Radiation Exposure and Hazard Statement

To ensure compliance with FCC RF exposure requirements, this device must be installed in a location such that the antenna of the device will be greater than 20 cm (8 in.) away from all persons. Using higher gain antennas and types of antennas not covered under the FCC certification of this product is not allowed. Installers of the radio and end users of the product must adhere to the installation instructions provided in this manual.

This transmitter must not be co-located or operating in conjunction with any other antenna or transmitter.

Non-Modification Statement

Use only the supplied internal antenna. Unauthorized antennas, modifications, or attachments could damage the AP 8120-R00 and violate FCC regulations. Any changes or modifications not expressly approved by the party responsible for compliance could void the user's authority to operate this equipment.

Deployment Statement

This product is certified for indoor deployment only. **Do not** install or use this product outdoors.

Dynamic Frequency Selection (DFS) in the 5.0 GHz UNII bands

The AP 8120-R00 access point has been prohibited, via software, from operating in the 5250 to 5350 MHz and 5470 to 5725 MHz frequency bands for the US and Canada because it cannot meet the DFS requirements as outlined in the rules of the FCC for Part 15, Subpart E that come into force on July 20, 2007.

Canadian IC Statements

IC: (Applies to AP 8120-R00)

Operation is subject to the following two conditions in Canada:

1. This device may not cause interference, and
2. This device must accept any interference, including interference that may cause undesired operation of the device.

To prevent radio interference to the licensed service (i.e. co-channel Mobile Satellite systems) this device is intended to be operated indoors and away from windows to provide maximum shielding. Equipment (or its transmit antenna) that is installed outdoors is subject to licensing and not supported by the AP 8120-R00 access point.

Because high power radars are allocated as primary users (meaning they have priority) in the 5250 to 5350 MHz band, these radars could cause interference and/or damage to license exempt WLAN devices.

European Union and European Free Trade Association (EFTA) Regulatory Compliance

This equipment may be operated in the countries that comprise the member countries of the European Union and the European Free Trade Association. These countries, listed in the following paragraph, are referred to as The European Community throughout this document:

AUSTRIA, BELGIUM, BULGARIA, CYPRUS, CZECH REPUBLIC, DENMARK, ESTONIA, FINLAND, FRANCE, GERMANY, GREECE, HUNGARY, IRELAND, ITALY, LATVIA, LITHUANIA, LUXEMBOURG, MALTA, NETHERLANDS, POLAND, PORTUGAL, ROMANIA, SLOVAKIA, SLOVENIA, SPAIN, SWEDEN, UNITED KINGDOM, ICELAND, LICHTENSTEIN, NORWAY, SWITZERLAND.

The Avaya WLAN 8100 AP 8120-R06 access point communicates with an Avaya WLAN 8100 Wireless Controller using a standard CAT-5 (Category 5) or higher 1000 Mbps twisted pair Ethernet cable to provide wireless local area networking (WLAN) capabilities. The Avaya WLAN 8100 AP 8120-R06 access point includes two 802.11a+n, b/g+n radios and one, six element, dual-band antenna omnidirectional internal antenna.

Declaration of Conformity

Marking by this symbol



indicates compliance with the Essential Requirements of the R&TTE Directive of the European Union (1999/5/EC). This equipment meets the following conformance standards:

Safety: EN 60950-1:2001 + A11:2004

EMC: EN 55022:2006, EN 55024:1998 + A1:2001 + A2:2003, EN 301-489-1 v1.6.1, EN 301-489-17 v1.2.1, CISPR22:2005, CISPR24

Including: EN 61000-3-2, -3-3, -4-2, -4-3, -4-4, -4-5, -4-6 and -4-11.
The product is also licensed as required for additional country specific standards as required for the International Marketplace.

Radio: EN 300-328 v.1.7.1 (2006-10) & EN 301-893 v.1.5.1 (2008-12)

DEVIATION: The AP 8120-R00 access point was tested to and are compliant with all of the technical specifications of EN 301-893 v1.5.1 for operation in the 5.0 GHz bands, except the DFS requirements in the 5600 – 5650 MHz band.

IEEE 802.11a operation in the 5250 to 5350 MHz and 5470 to 5725 MHz frequency bands is governed by ETSI EN 301-893 v1.5.1 and the R&TTE Directive 1999/5/EC. Effective July 1, 2008, EN 301-893 v1.5.1 was updated to require compliance with 0.8 µsecond pulse widths and staggered PRF's in the 5470 – 5725 MHz band. The AP 8120-R00 access point meets compliance with these new mandates by disabling operation, via software, on channels 120, 124, 128 and 132 in the 5600 to 5650 MHz frequency band because it cannot meet the 0.8 µsecond pulse width and staggered PRF DFS requirements as outlined in the updated EN 301-893 v1.5.1 standard.

Electromagnetic compatibility and Radio spectrum Matters (ERM); Wideband transmission systems; Data transmission equipment operating in the 2,4 GHz ISM band and using wide band modulation techniques and Broadband Radio Access Networks (BRAN); 5 GHz high performance RLAN. Certifications are harmonized to the EN standards covering essential requirements under article 3.2 of the R&TTE Directive.

SAR: EN 50385:2002

European Community Declaration of Conformity

WLAN Radio Model AP 8120-R06, as stated in the following Declarations of Conformity, represents all models in the AP 8120-R06 as listed above.

Bulgaria	, аваял , WLAN AP 8120-R06, 1999/5
Czech Republic	Èesky Avaya tímto prohlašuje, že tento WLAN Rádio Model AP 8120-R06, je ve shodi se základními požadavky a dalšími pøíslušnými ustanoveními smìrnice 1999/5/ES.
Denmark	Dansk Undertegnede Avayaerklærer herved, at følgende udstyr WLAN Radio Model AP 8120-R06, overholder de væsentlige krav og øvrige relevante krav i direktiv 1999/5/EF.
English	English Hereby, Avaya declares that this WLAN Radio Model AP 8120-R06, is in compliance with the essential requirements and other relevant provisions of Directive 1999/5/EC.
Estonia	Eesti Käesolevaga kinnitab Avayaseadme WLAN Radio Model AP 8120-R06, vastavust direktiivi 1999/5/EÜ põhinõuetele ja nimetatud direktiivist tulenevatele teistele asjakohastele sätetele.
Finland	Suomi Avayavakuuttaa täten että WLAN Radio Esikuvallinen AP 8120-R06, tyyppinen laite on direktiivin 1999/5/EY oleellisten vaatimusten ja sitä koskevien direktiivin muiden ehtojen mukainen.
France	Français Par la présente Avaya déclare que l'appareil Model Par radio AP 8120-R06 de WLAN, est conforme aux exigences essentielles et aux autres dispositions pertinentes de la directive 1999/5/CE.
Germany	Deutsch Hiermit erklärt Avaya., dass sich das Gerät WLAN Radiomodell AP 8120-R06, in Übereinstimmung mit den grundlegenden Anforderungen und den übrigen einschlägigen Bestimmungen der Richtlinie 1999/5/EG befindet.
Greece	ΕΛΛΗΝΙΚΗ ΜΕ ΤΗΝ ΠΑΡΟΥΣΑ Nortel ΔΗΛΩΝΕΙ ΟΤΙ WLAN Radio Model 8120 ΣΥΜΜΟΡΦΩΝΕΤΑΙ ΠΡΟΣ ΤΙΣ ΟΥΣΙΩΔΕΙΣ ΑΠΑΙΤΗΣΕΙΣ ΚΑΙ ΤΙΣ ΛΟΙΠΕΣ ΣΧΕΤΙΚΕΣ ΔΙΑΤΑΞΕΙΣ ΤΗΣ ΟΔΗΓΙΑΣ 1999/5/ΕΚ
Hungary	Magyar Alulírott, Avayanyilatkozom, hogy a WLAN Rádió Minta AP 8120-R06, megfelel a vonatkozó alapvető követelményeknek és az 1999/5/EC irányelv egyéb előírásainak.

12 Regulatory Compliance Statements

Italy	Italiano Con la presente Avaya dichiara che questo Modello Radiofonico AP 8120-R06 di WLAN, è conforme ai requisiti essenziali ed alle altre disposizioni pertinenti stabilite dalla direttiva 1999/5/CE.
Latvia	Latviski Ar šo Avayadeklarāc, ka WLAN Radio Model AP 8120-R06, atbilst Direktīvas 1999/5/EK būtiskajām prasībām un citiem ar to saistītajiem noteikumiem.
Lithuania	Lietuvių Šiuo Avayadeklaruoja, kad šis WLAN Radio Model AP 8120-R06, atitinka esminius reikalavimus ir kitas 1999/5/EB Direktyvos nuostatas.
Malta	Malti Hawnhekk, Avaya., jiddikjara li dan WLAN Radio Model AP 8120-R06, jikkonforma mal-tijiet essenzjali u ma provvedimenti orajni relevanti li hemm fid-Direttiva 1999/5/EC.
Netherlands	Netherlands Hierbij verklaart Avaya dat het toestel WLAN Radiomodel AP 8120-R06, in overeenstemming is met de essentiële eisen en de andere relevante bepalingen van richtlijn 1999/5/EG.
Poland	Polski Niniejszym Avaya oświadczam, że WLAN Radio Model AP 8120-R06, jest zgodny z zasadniczymi wymogami oraz pozostałymi stosownymi postanowieniami Dyrektywy 1999/5/EC.
Portugal	Português Avaya declara que este Modelo De rádio AP 8120-R06 de WLAN, está conforme com os requisitos essenciais e outras disposições da Directiva 1999/5/CE.
Romania	Român Astfel, Avaya declară că acest WLAN Radio Model AP 8120-R06, este în conformitate cu cerințele necesare și proviziile alte semnificative de Directive 1999/5/EC.
Slovakia	Slovensky Avaya týmto vyhlasuje, že WLAN Radio Model AP 8120-R06 spĺna základné požiadavky a všetky príslušné ustanovenia Smernice 1999/5/ES.
Slovenia	Slovensko Avaya izjavlja, da je ta WLAN Radio Model AP 8120-R06, v skladu z bistvenimi zahtevami in ostalimi relevantnimi določili direktive 1999/5/ES.

Spain	<p>Español</p> <p>Por medio de la presente Avaya declara que el Modelo De radio AP 8120-R06 de WLAN, cumple con los requisitos esenciales y cualesquiera otras disposiciones aplicables o exigibles de la Directiva 1999/5/CE.</p>
Sweden	<p>Svenska</p> <p>Härmed intygar Avaya elatt denna WLAN Radiotelegrafer till Modell AP 8120-R06, står i överensstämmelse med de väsentliga egenskapskrav och övriga relevanta bestämmelser som framgår av direktiv 1999/5/EG.</p>

Countries of Operation and Restrictions of Use in the European Community

Operation Using the 2.400 to 2.4835 GHz Channels in the European Community

The professional installer should use the configuration utility provided with this product to verify the current channel of operation, the expected transmit power level, and to confirm that the device is operating in conformance with the spectrum usage rules for the selected European Community country. **If operation is occurring outside of the allowable channels as indicated in this guide, then operation of the product must cease immediately** and the installer must consult with the local technical support staff responsible for the wireless network.

This device is intended to be operated in all countries of the European Community. Additional restrictions of use for the AP 8120-R00 access point within the European Community countries in the 2.400 to 2.4835 GHz band are listed below.

- The frequencies associated with channels 1 to 13 in the 2.400 to 2.4835 GHz band are allowed to be used either indoors or outdoors in all countries of the European Community, except where noted below.
- In France, the following operation is permitted:
 - Indoor operation is permitted in the 2.400 to 2.4835 GHz band on channels 1 to 13 at a maximum EIRP of 100 mW (20 dBm).

The AP 8120-R06 access point, using the internal antennas, are guaranteed to meet this limit by automatically adjusting the transmit power level through the operating software.

Operation Using the 5.15 to 5.25 GHz, 5.25 to 5.35 GHz, and 5.470 to 5.725 GHz Channels in the European Community

To remain in conformance with European National spectrum usage laws, follow the channel limitations associated with the 5 GHz bands as specified in this document. The professional installer should verify the current channel of operation and the expected transmit power level of

the AP 8120-R00 access point to confirm that the device is operating in conformance with the spectrum usage rules for the European Community country where the unit is being installed. **If operation is occurring outside of the allowable frequencies or above the power levels, as indicated in this guide, then operation of the product must cease immediately** and the installer must consult with the local technical support staff responsible for the wireless network.

This device is intended to be operated in all countries of the European Community. Additional restrictions of use for the AP 8120-R00 access points within the European Community countries in the 5.15 to 5.25 GHz, 5.25 to 5.35 GHz, and 5.470 to 5.725 GHz bands are listed below.

- This device is restricted to indoor use only when operated in the European Community using the 5.15-5.25 GHz and 5.25-5.35 GHz bands, which includes channels 36, 40, 44, 48, 52, 56, 60 & 64. • The 5 GHz Turbo Mode feature is not allowed for operation in any European Community country.

Dynamic Frequency Selection (DFS)

The AP 8120-R00 access point implements a DFS feature in accordance with the limits in EN 301-893 v1.5.1, Section 4.7 and Annex D, Tables D.1, D.2 & D.4 for a device operating in the mode defined as “Master”. Section 4.7 and Tables 5 of this document define the requirements prior to using a channel and during normal operation for a Master device (i.e., Interference Detection Threshold, Channel Availability Check Time, Uniform Spreading, Channel Closing Transmission Time and Channel Move Time). This product qualifies for this category since the maximum achievable transmit power is greater than 23 dBm per the requirements of Table D.2 in Annex D of the standard.

IEEE 802.11a operation in the 5250 to 5350 MHz and 5470 to 5725 MHz frequency bands is governed by ETSI EN 301-893 v1.5.1 and the R&TTE Directive 1999/5/EC. Effective July 1, 2008, EN 301-893 v1.5.1 was updated to require compliance with 0.8 μsecond pulse widths and staggered PRF's in the 5470 – 5725 MHz band. The AP 8120-R00 access point meets compliance with these new mandates by disabling operation, via software, on channels 120, 124, 128 and 132 in the 5600 to 5650 MHz frequency band because it cannot meet the 0.8 μsecond pulse width and staggered PRF DFS requirements as outlined in the updated EN 301-893 v1.5.1 standard.

Transmit Power Control

European Regulatory requirements specify that wireless devices must employ Transmit Power Control (TPC) to reduce the potential for interference to other communication systems operating in the 5 GHz

frequency bands. This device includes a provision for adjustment of Transmit Power in accordance with the limits in EN 301-893 v1.5.1, Sections 4.4.2.1 and 4.4.2.2.

Antenna Statement

Intentional radiators, such as the Avaya WLAN 8100 AP 8120-R00 and AP 8120-R06 access points, are not intended to be operated with any antenna(s) other than those furnished by Avaya. An intentional radiator may only be operated with the antenna(s) with which it is authorized.

Use of an antenna not specifically authorized by Avaya may not comply with local regulatory requirements with respect to radiated emission limits and may result in illegal operation of the product. The installer of the wireless system and associated antenna is required to ensure that only those antennas specifically approved by Avaya are deployed with the intentional radiator.

Be sure to associate the appropriate antenna model number and localized regulatory region when selecting the Avaya authorized antenna(s).

English

Using the following procedures and information when installing the Avaya AP 8120-R00 and AP 8120-R06 access points.

Cable requirements

The Ethernet ports on the access point cannot accept a CAT-5 cable that has an uneven sheath as shown below. The RJ-45 connector on the cable will not seat properly in the receptacle on the access point. Use a CAT-5 cable with an even sheath instead.

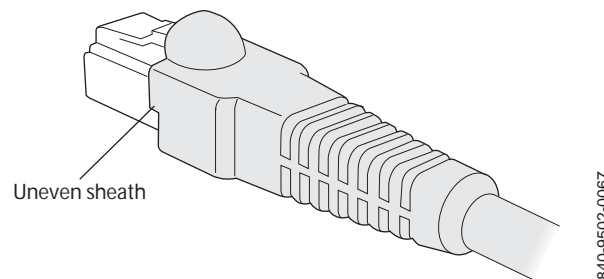

Mounting a wireless LAN access point on a wall

The mounting bracket is designed to use wall anchors with threaded section diameters ranging between 3.5mm and 4.5mm. If wall anchors have threaded diameters greater than 3.5mm, only the two mounting holes marked 'A' may be used. If wall anchors have threaded diameters of less than 3.5mm, the holes marked 'A' and the holes marked 'B' may be used. All wall anchors must have a head diameter of less than 10mm or the wall mounting bracket cannot be installed over them.

Perform the following procedure to mount a wireless LAN access point on a wall:

Procedure steps

Step	Action
1	Locate the appropriate position of the wall anchors. The wall anchors should be 95mm apart horizontally and 80mm apart vertically.

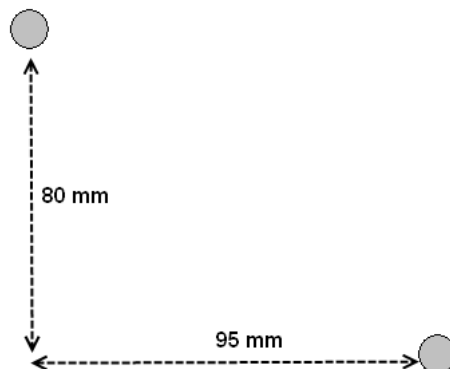

The wall bracket is designed to use a minimum of 2 anchors and a maximum of 4.

- 2 Install the screws into the wall anchors but do not seat them fully, leave at least a 2mm gap between the screw head and the wall.
- 3 Slip the wall bracket over the heads of the screws and slide the bracket to the right as viewed facing the wall.

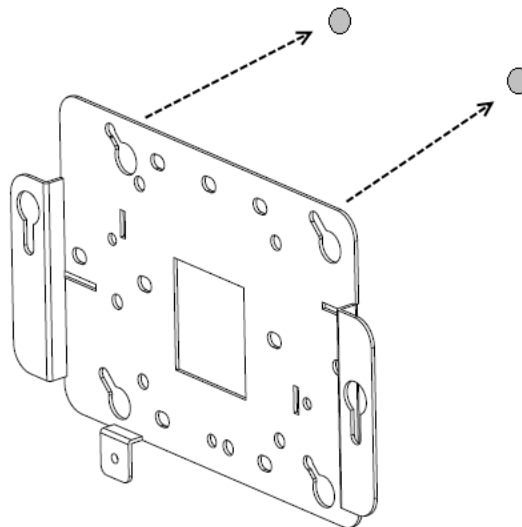

- 4 Tighten the screws to secure the wall mounting bracket tightly against the wall.

- 5 Align the mounting tabs on the bottom of the access point sheet metal enclosure with the vertically oriented keyhole slots in the mounting bracket.

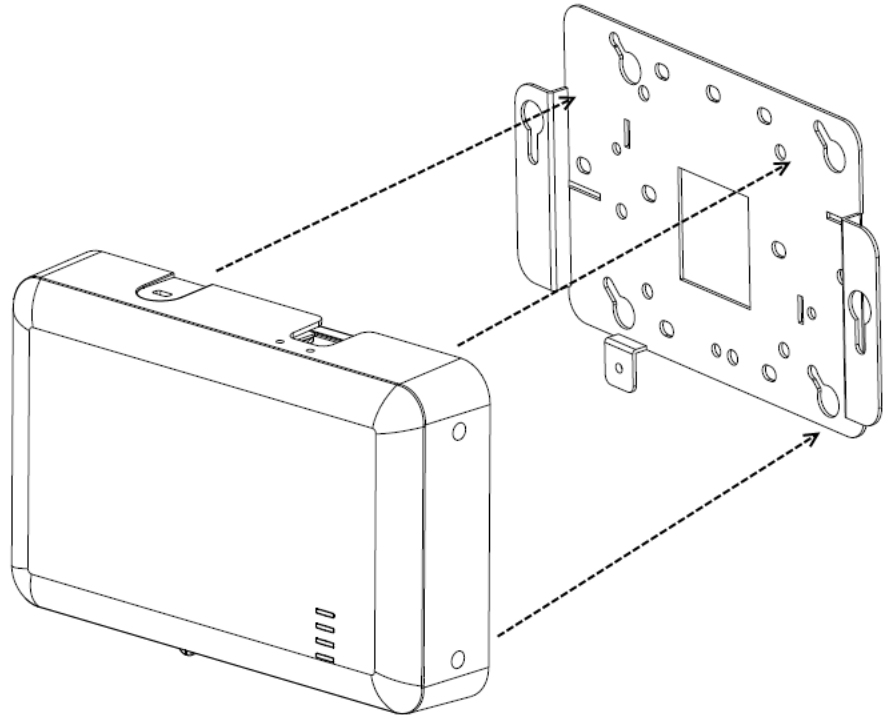

- 6 Allow the access point to slide down the keyhole slots, making sure the access point mounting tabs are seated at the bottom of the slot.
- 7 Secure the access point to the wall mounting bracket and tighten the thumbscrews.
- 8 Verify that the access point is secured to both the bracket and to the wall.

--End--

Installing an Access Point with a ceiling grid adaptor

The ceiling grid adaptor comes with two interlocking bracket parts. The larger bracket includes keyhole shaped slots which mate with tabs on the under surface of the AP and a threaded hole that mates with the captive thumbscrew on the AP. The smaller bracket also includes a captive fastener and it can be oriented with respect to the larger bracket in two different ways corresponding to narrow or wide ceiling grids.

Perform the following procedure to install the access point with a ceiling grid adaptor:

Procedure steps

Step	Action
1	Secure a safe work environment. Obtain a ladder that allows easy access to the ceiling grid system.
2	Identify an appropriate location on the ceiling grid where the ceiling T-bars are safely accessible and where the ceiling tiles can be temporarily elevated and cleared away from the work area. The adaptor bracket assembly is intended for use with the thin section grid runners, not the thicker section runners used to cross large spans. To provide access for hands and tools, use a pair of pencils or sticks to hold up the ceiling tiles out of the grid. Doing this provides easy access for securing the bracket to the grid.
3	Mount the larger bracket to the grid. While installing, pay attention to the width of the grid strip in order to ascertain the appropriate orientation for the smaller bracket which is installed next.

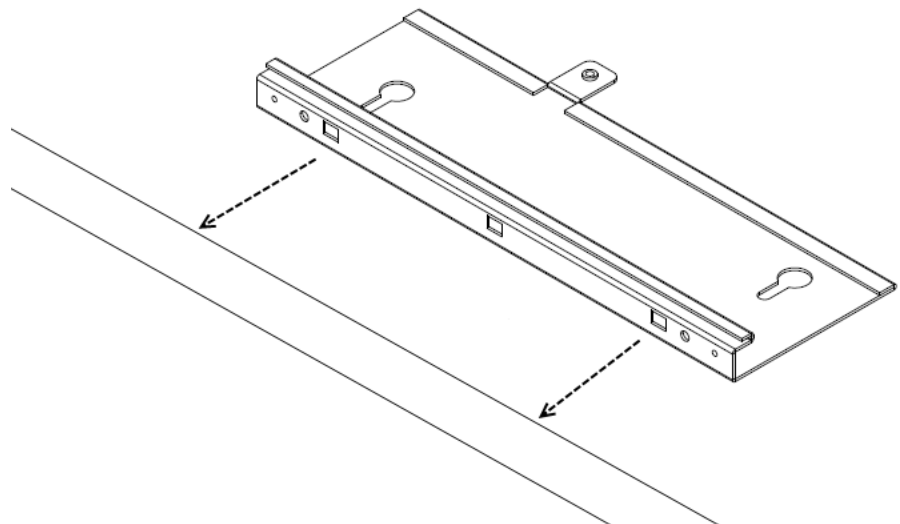

- 4 Mount the interlocking small bracket to the large bracket and clamp the two pieces together on the grid. The smaller bracket has tabs formed into it which engage slots in the larger tab. This allows the two parts to slide together and lock to one another. When this is done, the two brackets effectively clamp themselves around the ceiling grid. When the two halves of the bracket are correctly slid together, the captive fastener in the small bracket should engage threads provided in the larger bracket. Use a screwdriver to screw down the captive fastener. Securing the two brackets in this manner is essential to prevent them from disengaging from one another. Tighten the captive fastener screw securely.

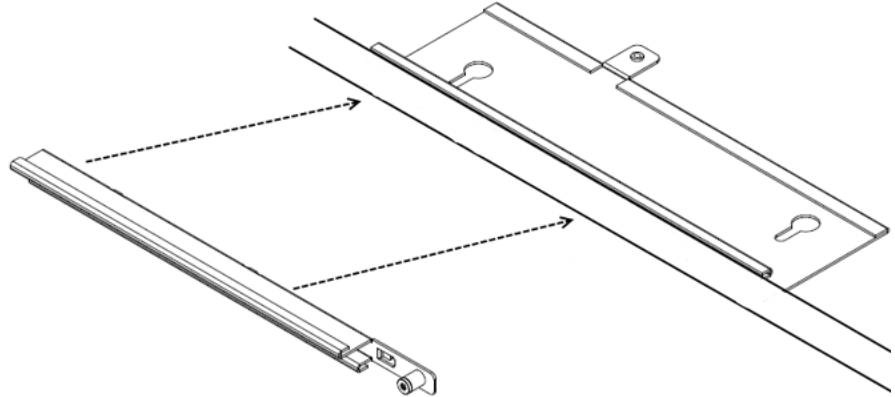

- 5 Attach the access point to the bracket. Align the access point securing tabs with the keyhole slots in the ceiling grid bracket and carefully slide the access point onto the ceiling grid bracket assembly. If the access point and the bracket assembly are correctly engaged, it should be possible to engage the access points captive thumbscrew into the threaded tab provided on the ceiling grid bracket.

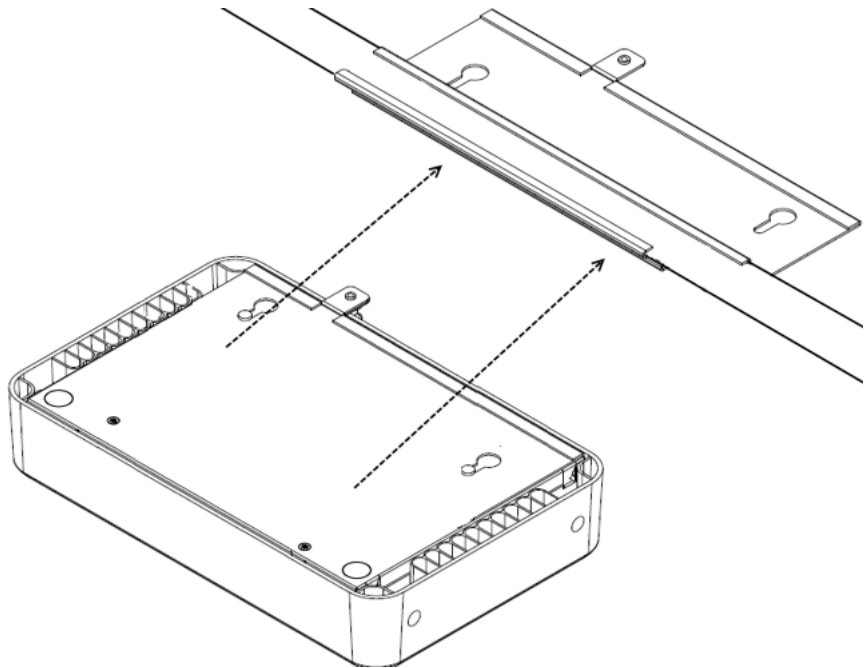

- 6 Make electrical connections and return ceiling tiles.

--End--

Safety Messages



CAUTION

The Avaya WLAN Access Point 8120 radios are disabled by default and can be enabled only by a system administrator.



WARNING

This situation or condition can cause injury.



WARNING

High voltage. This situation or condition can cause injury due to electric shock.



WARNING

Only qualified service personnel must perform installation. Read and follow all warning notices and instructions marked on the product or included in the documentation.



WARNING

Install this device in such a manner as to maintain a minimum of 20 cm (7.9 inches) separation distance between the radiating element(s) and all persons. This safety warning conforms with FCC radio frequency exposure limits.



WARNING

Do not operate access point near unshielded blasting caps or in an otherwise explosive environment unless the device has been modified for such use by qualified personnel.



WARNING

Do not touch or move the access point when the antennas are transmitting or receiving.



WARNING

Before using a wireless device in a hazardous location, consult the local codes, national codes, and safety directors of the location for usage constraints.

Deutsch

Verwenden Sie die folgenden Verfahren und Informationen zur Installation der Access Points Avaya AP 8120-R00 und AP 8120-R06.

Kabelanschlüsse

Die Ethernet-Ports an den Access Points können nicht mit CAT 5-Kabeln mit einer abgesetzten Kabelhülse verbunden werden (siehe unten). Der RJ-45-Anschluss des Kabels sitzt in diesem Fall nicht richtig auf dem Port des Access Points auf. Verwenden Sie stattdessen ein CAT 5-Kabel mit einer geraden Kabelhülse.

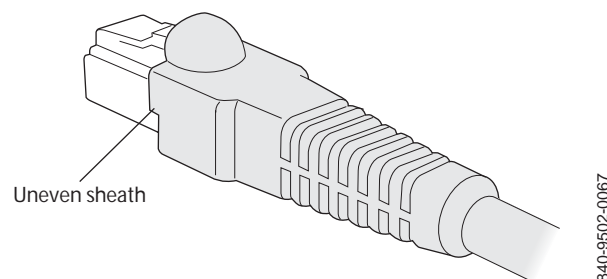

Wandmontage eines Wireless LAN Access Points

Die Wandhalterung wird mit Wanddübeln mit einem Gewindedurchmesser von 3,5-4,5 mm befestigt. Verwenden Sie bei Gewindedurchmessern über 3,5 mm lediglich die beiden mit A“ markierten Montagelöcher der Wandhalterung. Bei Gewindedurchmessern unter 3,5 mm können Sie die mit A“ und die mit B“ markierten Montagelöcher verwenden. Der Kopfdurchmesser der Wanddübel muss kleiner als 10 mm sein, damit die Wandhalterung richtig montiert werden kann.

So führen Sie die Wandmontage eines Wireless LAN Access Points durch:

Procedure steps

Step	Action
1	Bestimmen Sie die richtige Position der Wanddübel. Die Wanddübel müssen waagrecht in einem Abstand von 95 mm und senkrecht in einem Abstand von 80 mm installiert werden.

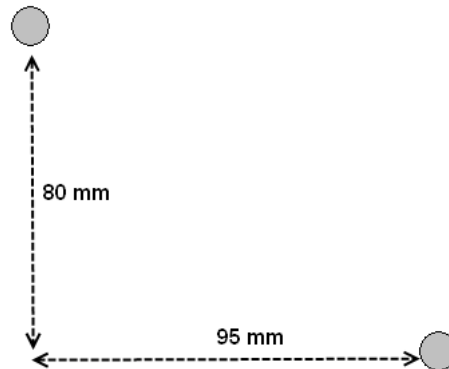

Die Wandhalterung wird mit mindestens 2 und höchstens 4 Dübeln befestigt.

- 2 Drehen Sie die Schrauben in die Wanddübel, ohne sie ganz festzuziehen. Lassen Sie einen Abstand von mindestens 2 mm zwischen dem Schraubenkopf und der Wand.
- 3 Setzen Sie die Wandhalterung auf die Schraubenköpfe auf. Schieben Sie die Halterung nach rechts (von Ihnen aus gesehen).

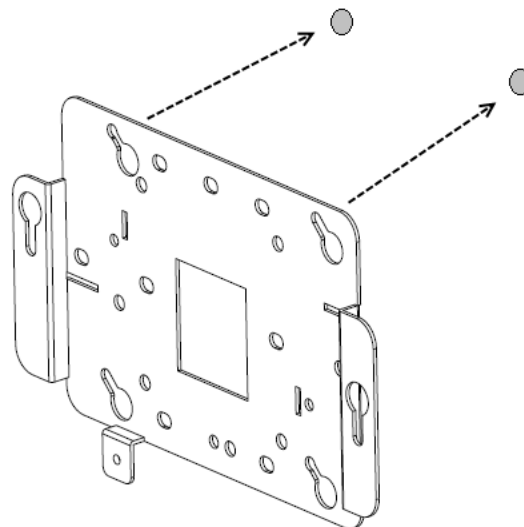

- 4 Ziehen Sie die Schrauben an, um die Wandhalterung sicher an der Wand zu befestigen.
- 5 Richten Sie die Montagelaschen unten am Metallgehäuse des Access Points mit den senkrechten Längsschlitzern an der Wandhalterung aus.

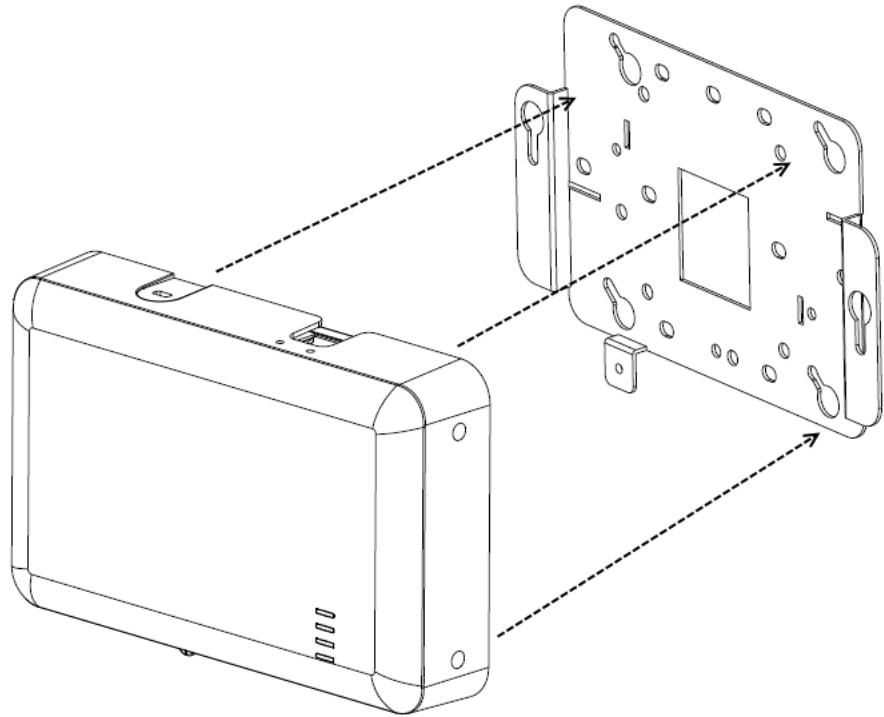

- 6 Schieben Sie den Access Point vorsichtig in den Längsschlitz nach unten, sodass die Montagelaschen des Access Points am unteren Rand der Längsslitze aufsitzen.
- 7 Befestigen Sie den Access Point an der Wandhalterung, und ziehen Sie die Daumenschrauben an.
- 8 Überprüfen Sie, ob der Access Point sicher an der Wandhalterung und an der Wand angebracht ist.

--End--

Deckenmontage eines Access Points (Rasterdecke)

Der Adapter für die Deckenmontage verfügt über zwei ineinander greifende Halterungen. Die Montagelaschen unten am Access Point passen in die Längsschlitze an der größeren Halterung. Die unverlierbare Schraube am Access Point wird in das Gewindeloch an der größeren

Halterung geschraubt. Die unverlierbare Schraube an der kleineren Halterung kann je nach Rastergröße auf zweierlei Weise an der größeren Halterung ausgerichtet werden.

So führen Sie die Deckenmontage eines Access Points an einer Rasterdecke durch:

Procedure steps

Step	Action
1	Sorgen Sie für eine sichere Arbeitsumgebung. Besorgen Sie sich eine Leiter, die Zugang zur Rasterdecke ermöglicht.
2	Bestimmen Sie eine geeignete Montageposition an der Rasterdecke, an der die T-Profile sicher zugänglich sind und die Deckenplatten vorübergehend abgehängt werden können. Der Adapter für die Deckenmontage wird an den dünneren Querschienen befestigt, nicht an den dickeren und längeren Haupttrageschienen. Um ungehindert arbeiten zu können, heben Sie die Deckenplatten mit zwei Stiften oder Stäben nach oben aus dem Deckenraster. So erhalten Sie einfachen Zugang zum Befestigen der Halterung.
3	Befestigen Sie die größere Halterung am Deckenraster. Achten Sie dabei auf die Breite der Schiene, um die richtige Positionierung für die kleinere Halterung zu bestimmen, die anschließend installiert wird.

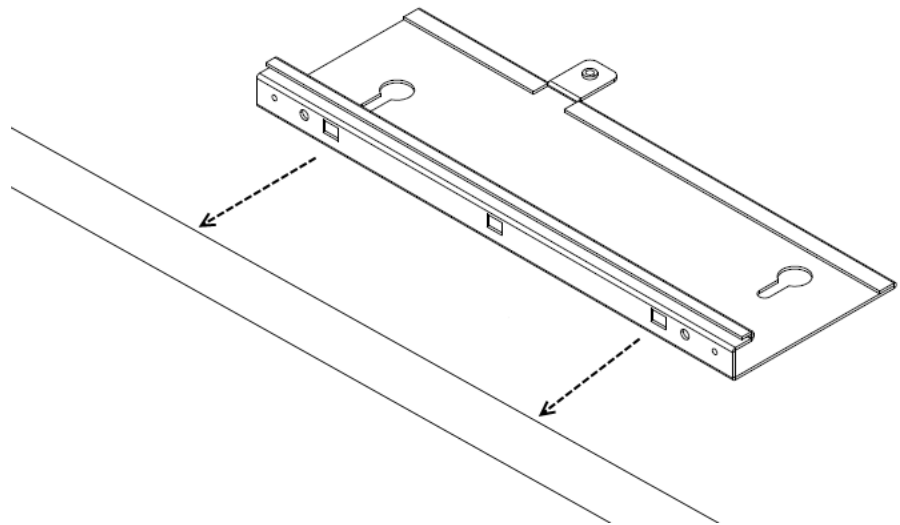

- 4 Montieren Sie die kleinere Halterung so an der größeren, dass sie ineinander greifen, und klemmen Sie die beiden Halterungen zusammen. Die Montagelaschen an der kleineren Halterung passen in die Schlitze an der größeren Halterung. So können die

beiden Halterungen sicher arretiert und um die Deckenschiene herum montiert werden. Wenn Sie die beiden Halterungen richtig miteinander verbunden haben, passt die unverlierbare Schraube an der kleineren Halterung in das Gewinde in der größeren Halterung. Sichern Sie die unverlierbare Schraube mit einem Schraubendreher. Es ist sehr wichtig, die beiden Halterungen auf diese Weise zu sichern, damit sie sich nicht voneinander lösen. Ziehen Sie die unverlierbare Schraube fest an.

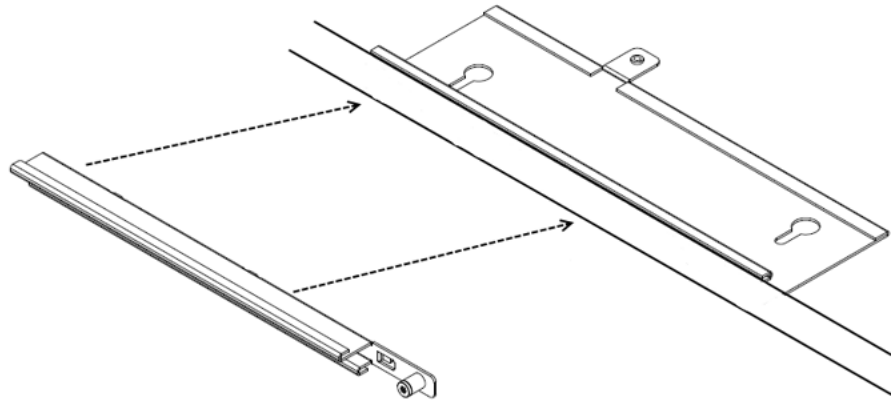

- 5 Befestigen Sie den Access Point an der Halterung. Richten Sie die Sicherungslaschen am Access Point an den Längsschlitz an der Deckenhalterung aus, und schieben Sie den Access Point vorsichtig auf die montierte Deckenhalterung. Wenn der Access Point richtig auf die Deckenhalterung aufgesetzt ist, kann die unverlierbare Daumenschraube auf dem Access Point in das Gewinde an der Deckenhalterung geschraubt werden.

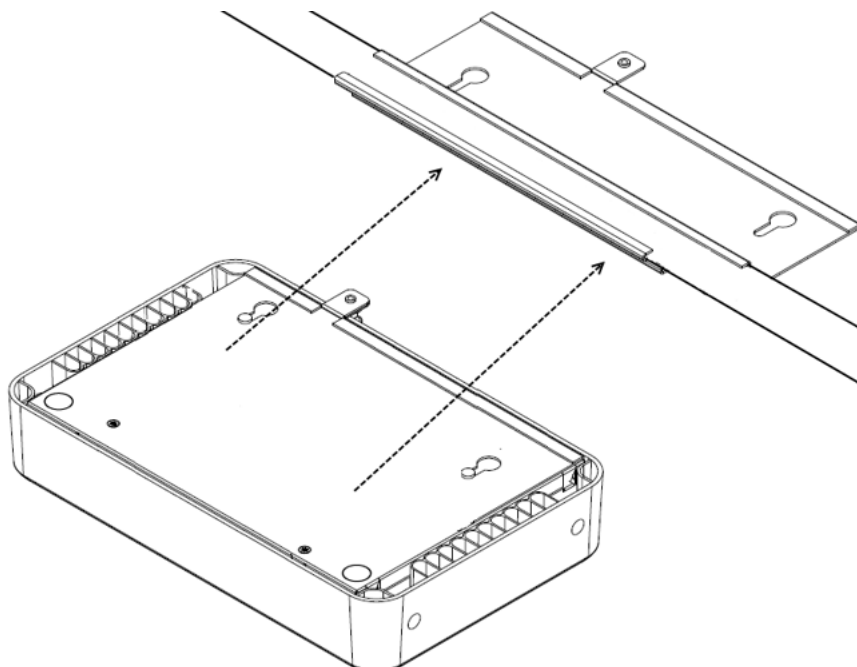

- 6 Stellen Sie die elektrischen Verbindungen her, und bringen Sie die Deckenplatten wieder an.

--End--

Sicherheitshinweise

Wir benötigen Übersetzungen für diese Meldungen und alle anderen Meldungen, die wir dem Dokument hinzufügen möchten.



CAUTION

Die Frequenzempfänger für den Avaya WLAN Access Point 8120 sind standardmäßig deaktiviert und können nur von einem Systemadministrator aktiviert werden.



WARNING

Dieser Zustand bzw. diese Bedingung kann zu Verletzungen führen.



WARNING

Hochspannung. Dieser Zustand bzw. diese Bedingung kann aufgrund von Stromschlag zu Verletzungen führen.

**WARNING**

Die Installation darf nur von qualifiziertem Wartungspersonal durchgeführt werden. Lesen Sie alle Warnhinweise und Anweisungen auf dem Gerät bzw. in der Dokumentation.

**WARNING**

Installieren Sie das Gerät so, dass zwischen den Strahlungselementen und allen Personen ein Abstand von mindestens 20 cm gewährleistet ist. Diese Sicherheitswarnung entspricht den FCC-Grenzwerten für Hochfrequenzstrahlung.

**WARNING**

Setzen Sie den Access Point nicht in der Nähe von ungeschützten Zündkapseln oder in anderen Umgebungen mit Explosionsgefahr ein, es sei denn, das Gerät wurde von qualifiziertem Personal für einen solchen Einsatz modifiziert.

**WARNING**

Berühren oder bewegen Sie den Access Point nicht beim Senden oder Übertragen von Funksignalen.

**WARNING**

Informieren Sie sich vor der Verwendung eines Wireless-Geräts in einer Gefahrenumgebung über regionale und überregionale Vorschriften zu Nutzungsbeschränkungen sowie die Sicherheitsrichtlinien für den jeweiligen Standort.

Español

Al momento de instalar los puntos de acceso AP 8120-R00 y AP 8120-R06 de Avaya, tenga en cuenta el procedimiento y la información que se presentan a continuación.

Requisitos del cable

Los puertos Ethernet del punto de acceso no admiten cables CAT-5 con terminación de recubrimiento irregular, como el que se muestra en la siguiente imagen. En caso de usar uno de estos cables, el conector RJ-45 no encajará bien en la toma del punto de acceso. En su lugar, utilice cables CAT-5 con terminación de recubrimiento uniforme.

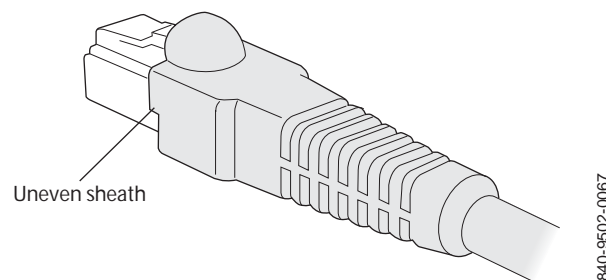

Montaje en la pared de un punto de acceso inalámbrico para redes LAN

El soporte de montaje está concebido para adosarse a la pared con tacos para pared (también denominados "tarugos" o "taquetes") cuyas secciones roscadas presenten un diámetro de entre 3,5 y 4,5 mm. Si los tacos para pared cuentan con diámetros de rosca superiores a 3,5 mm, sólo pueden utilizarse los dos orificios marcados con la letra A. En cambio, si los tacos cuentan con diámetros de rosca inferiores a 3,5 mm, pueden utilizarse tanto los orificios marcados con la letra A como los marcados con la letra B. El diámetro de la cabeza de los tacos no debe exceder los 10 mm; en caso contrario, no podrán pasarse por los orificios del soporte para la instalación.

A continuación, se presentan los pasos para montar en una pared un punto de acceso inalámbrico para redes LAN:

Procedure steps

Step	Action
1	Encuentre el lugar indicado para poner los tacos. La distancia entre los tacos debe ser de 95 mm en sentido horizontal y de 80 mm en sentido vertical.

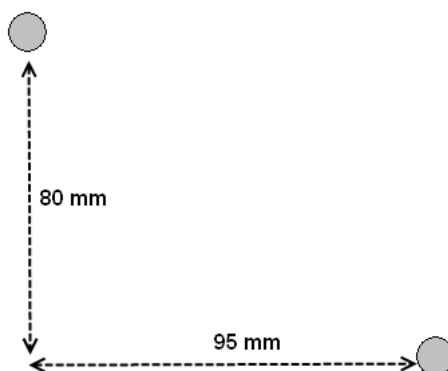

El soporte de pared puede adosarse con un mínimo de 2 tacos y con un máximo de 4.

- 2 Cuando llegue el momento de colocar los tornillos en los tacos, no los atornille del todo: deje un espacio de al menos 2 mm entre la cabeza del tornillo y la pared.
- 3 Coloque el soporte de pared por sobre las cabezas de los tornillos y muévelo hacia la derecha (desde la perspectiva de alguien ubicado de frente a la pared).

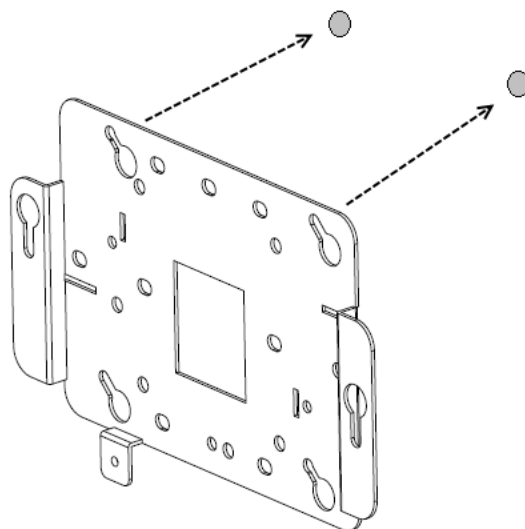

- 4 Termine de ajustar los tornillos hasta que el soporte quede bien sujeto contra la pared.
- 5 Alinee las lengüetas de montaje ubicadas en la parte inferior de la caja metálica del punto de acceso con las ranuras verticales con forma de cerradura del soporte de montaje.

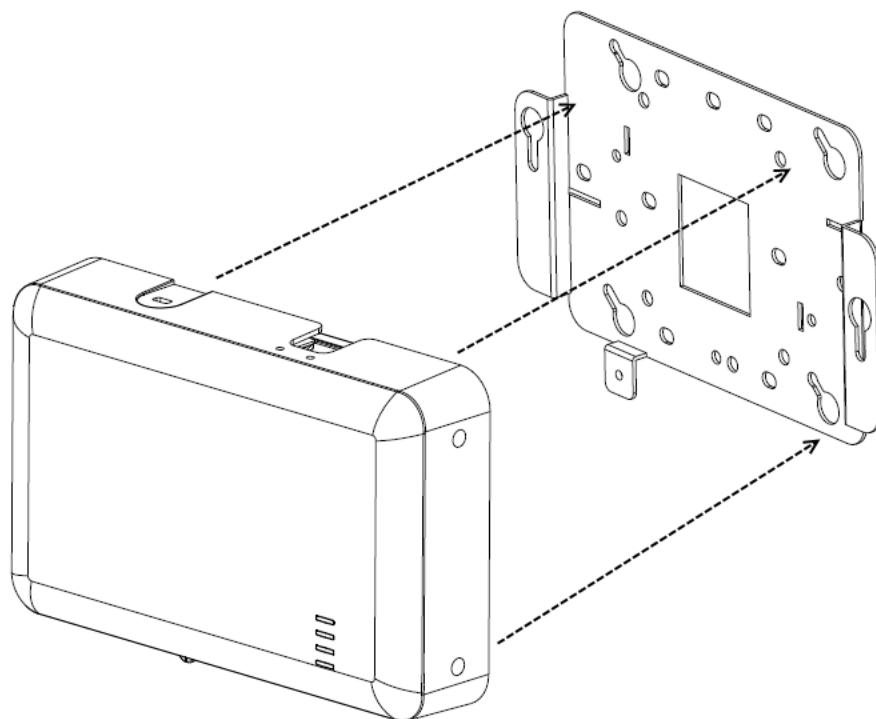

- 6 Inserte el punto de acceso y llévelo hacia abajo hasta que las lengüetas de montaje queden apoyadas en el extremo inferior de las ranuras con forma de cerradura.

- 7 Asegure el punto de acceso en el soporte de montaje y apriete los tornillos de ajuste manual.
- 8 Asegúrese de que el punto de acceso quede bien sujeto tanto al soporte como a la pared.

--End--

Instalación de un punto de acceso con un adaptador para estructuras de techos desmontables

El adaptador para estructuras de techos desmontables incluye un soporte de dos piezas que van conectadas entre sí. La pieza más grande tiene ranuras con forma de cerradura que coinciden con lengüetas ubicadas en la superficie inferior del punto de acceso, además de contar con un orificio roscado para el tornillo imperdible de ajuste manual del punto de acceso. La más pequeña también incluye un tornillo imperdible y puede orientarse de dos maneras distintas con respecto a la pieza de mayor tamaño a fin de adaptarse a estructuras de techos desmontables angostas y anchas .

Para instalar el punto de acceso con un adaptador para estructuras de techos desmontables, siga los pasos que se presentan a continuación:

Procedure steps

Step	Action
1	Tome las medidas necesarias para garantizar la seguridad del lugar de trabajo. Consiga una escalera que le permita llegar fácilmente a la estructura del techo desmontable.
2	Localice un lugar adecuado en la estructura del techo desmontable donde pueda accederse sin correr riesgos a los perfiles en T y donde las placas del cielorraso puedan levantarse y quitarse momentáneamente del sector de trabajo. El adaptador sirve para perfiles delgados de techos desmontables, no para los perfiles más gruesos que se utilizan para cubrir distancias mayores. A fin de poder acceder al punto de instalación, utilice un par de lápices o palitos para mantener levantadas las placas del cielorraso de la estructura. De esta manera, resulta fácil llegar con las manos y las herramientas para sujetar bien el soporte a la estructura.
3	Coloque la pieza más grande en la estructura. Mientras lo hace, fíjese cuál es el ancho del perfil con objeto de determinar la orientación adecuada de la pieza pequeña, que debe instalarse a continuación.

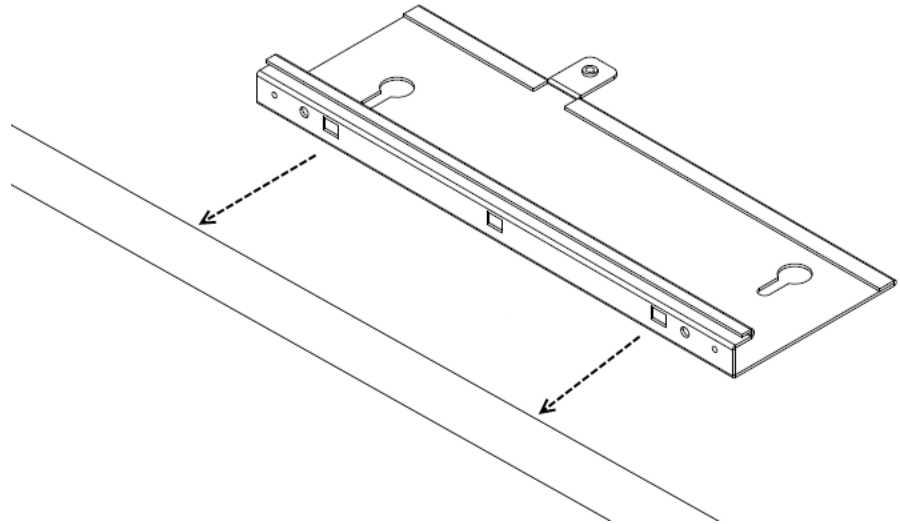

- 4 Monte la pieza pequeña en la grande y ajuste ambas a la estructura. La pieza pequeña cuenta con lengüetas que encajan en ranuras ubicadas en la pieza más grande. Por ende, al poner una contra la otra, ambas piezas quedan conectadas y se sujetan con firmeza a la estructura del techo desmontable. Si ambas piezas del adaptador quedaron bien colocadas, el tornillo imperdible de la pieza pequeña tiene que quedar alineado con el orificio roscado de la pieza grande. Utilice un destornillador para ajustar el tornillo imperdible. Es muy importante sujetar ambas piezas del soporte de esta manera para impedir que se suelten. Ajuste bien el tornillo imperdible.

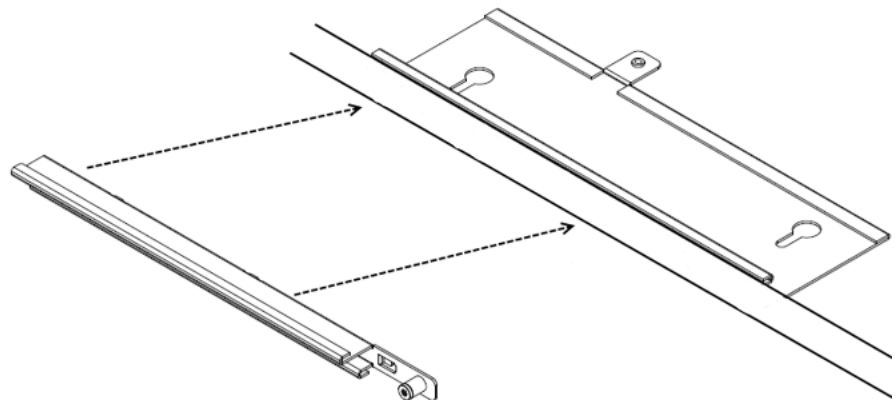

- 5 Monte el punto de acceso en el soporte. Alinee las lengüetas del punto de acceso con las ranuras con forma de cerradura del adaptador para estructuras de techos desmontables e inserte con cuidado el punto de acceso en el adaptador. Si tanto el punto de acceso como el adaptador están bien colocados, el tornillo imperdible de ajuste manual del punto de acceso

tiene que coincidir con la lengüeta roscada del adaptador para estructuras de techos desmontables. Ajustelo.

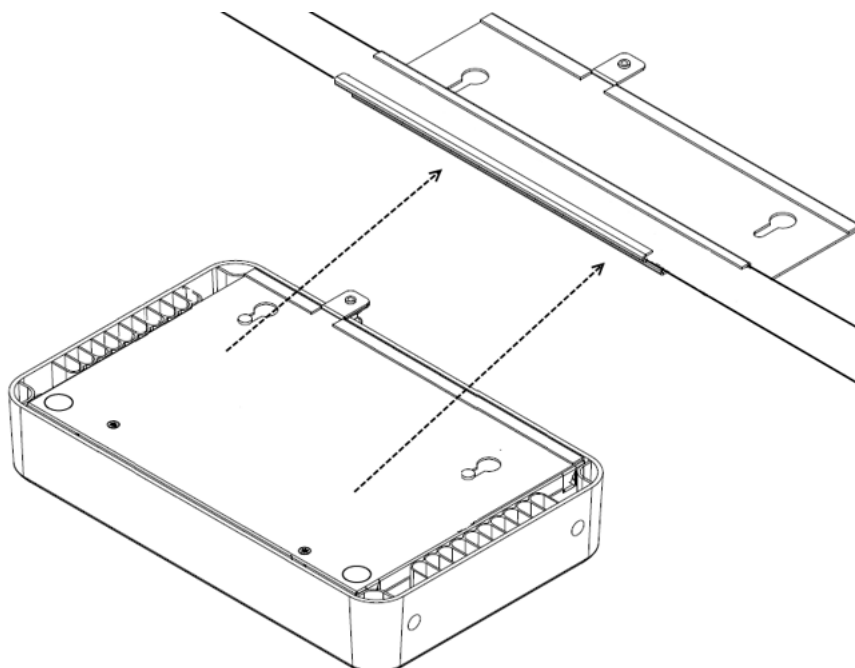

- 6 Realice las conexiones eléctricas necesarias y vuelva a colocar las placas del cielorraso.

--End--

Advertencias de seguridad

We need translations for these messages and any others we want to add to the document.



CAUTION

Las radios del punto de acceso WLAN 8120 de Avaya se encuentran desactivadas de manera predeterminada, y sólo puede activarlas un administrador de sistemas.



WARNING

Esta situación o estado puede provocar lesiones.



WARNING

Alta tensión. Esta situación o estado puede provocar lesiones por descarga eléctrica.

**WARNING**

La instalación debe dejarse en manos de personal de servicio técnico especializado. Lea y respete todas las advertencias de seguridad e instrucciones que figuren en el producto o en la documentación pertinente.

**WARNING**

Instale este dispositivo de modo que quede una separación de como mínimo 20 cm (7,9 pulg.) entre las personas y todo lo que emita señales de radiofrecuencia. Esta advertencia de seguridad se ajusta a los límites de exposición a señales de radiofrecuencia que dicta la FCC.

**WARNING**

No utilice el punto de acceso cerca de detonadores sin blindaje ni en ningún tipo de lugar en que exista riesgo de explosión a menos que personal especializado haya adaptado el dispositivo para dicho fin.

**WARNING**

No toque ni mueva el punto de acceso cuando las antenas estén transmitiendo o recibiendo información.

**WARNING**

Antes de utilizar un dispositivo inalámbrico en un entorno peligroso, familiarícese con las normativas locales y nacionales, y consulte al encargado de seguridad del lugar para estar al tanto de los usos permitidos.

Français

Utilisez les procédures et informations suivantes lors de l'installation des points d'accès AP 8120-R00 et AP 8120-R06 d'Avaya.

Configuration requise pour les câbles

Les câbles CAT-5 dotés d'une gaine irrégulière, comme illustré ci-dessous, ne sont pas adaptés aux ports Ethernet du point d'accès. Sur ce type de câble, le connecteur RJ-45 ne s'insère pas correctement dans le logement du point d'accès. Utilisez plutôt un câble CAT-5 doté d'une gaine régulière.

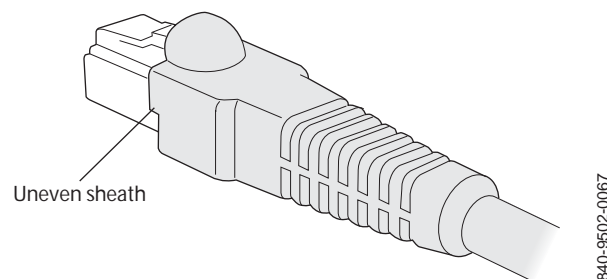

Montage mural du point accès WLAN

Le support de montage est conçu pour utiliser des dispositifs d'ancrage au mur équipés de diamètres de filetage de sections allant de 3,5 à 4,5 mm. Si le diamètre de filetage des dispositifs d'ancrage au mur est supérieur à 3,5 mm, seuls les deux trous de montage marqués par la lettre A peuvent être utilisés. Si le diamètre de filetage des dispositifs d'ancrage au mur est inférieur à 3,5 mm, les trous marqués par les lettres A et B peuvent être utilisés. Tous les dispositifs d'ancrage au mur doivent posséder un diamètre de tête inférieur à 10 mm, sinon ils ne peuvent pas prendre en charge l'installation du support de montage mural.

Pour monter un point d'accès WLAN sur un mur, procédez comme suit :

Procedure steps

Step	Action
1	Localisez l'emplacement adéquat pour les dispositifs d'ancrage au mur. Les dispositifs d'ancrage au mur doivent être écartés de 95 mm horizontalement et 80 mm verticalement.

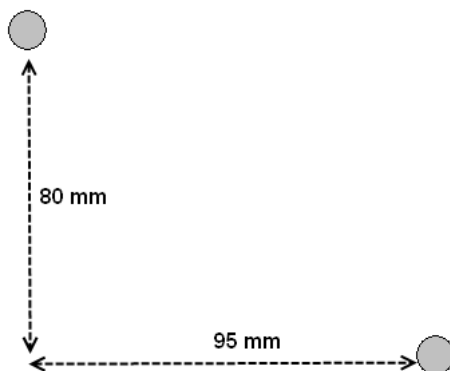

Le support mural est conçu pour utiliser entre 2 et 4 dispositifs d'ancrage.

- 2 Insérez les vis dans les dispositifs d'ancrage au mur sans les serrer complètement : laissez un espace de 2 mm au moins entre la tête de la vis et le mur.
- 3 Glissez le support mural sur les têtes des vis, puis faites-le glisser vers la droite (en regardant le mur).

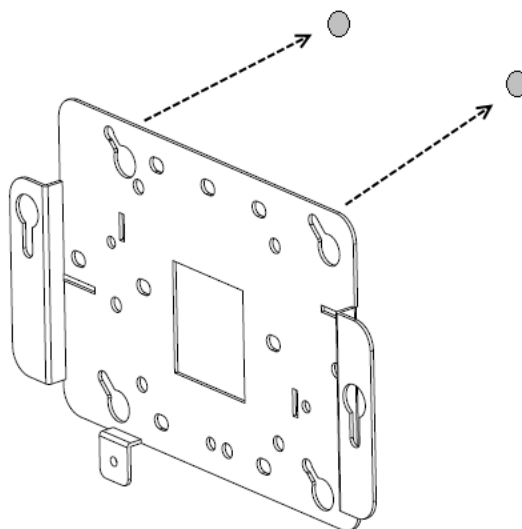

- 4 Serrez les vis afin de fixer solidement le support de montage mural au mur.

- 5 Alignez les languettes de montage de la partie inférieure du boîtier en tôle du point d'accès avec les encoches en trous de serrure du support de montage, orientées à la verticale.

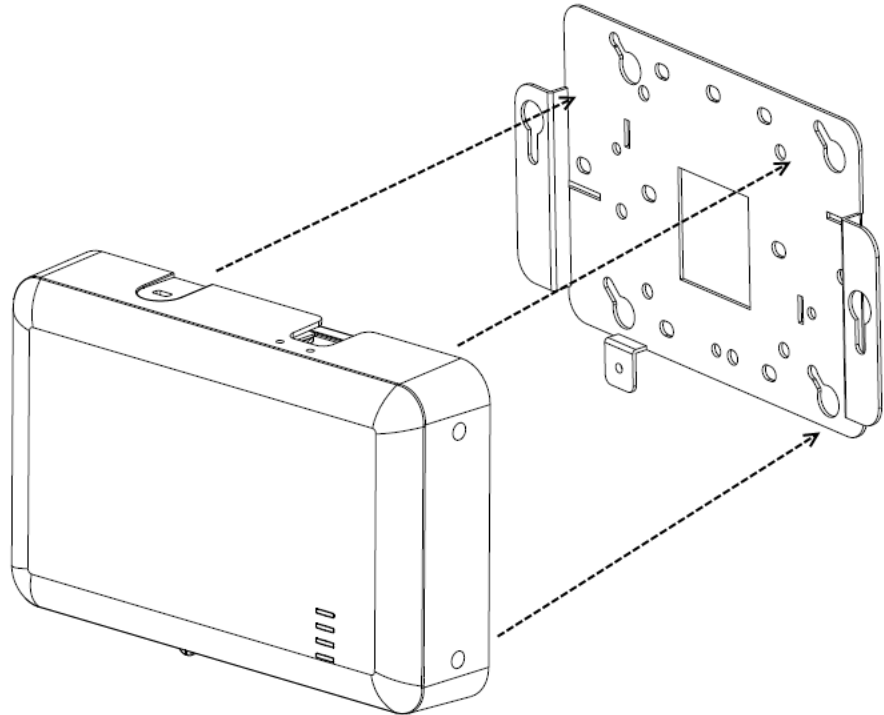

- 6 Faites glisser le point d'accès dans les encoches en trous de serrure en veillant à ce que ses languettes de montage soient correctement installées dans la partie inférieure des encoches.
- 7 Fixez solidement le point d'accès au support de montage mural et serrez les vis.
- 8 Vérifiez que le point d'accès est solidement fixé au support et au mur.

--End--

Installation du point accès avec un adaptateur pour grille de plafond

L'adaptateur pour grille de plafond est fourni avec deux pièces de support croisées. Le grand support est doté d'encoches en trous de serrure, adaptées aux languettes situées sur la face inférieure du point d'accès, et d'un trou taraudé adapté à la vis captive du point d'accès. Le petit support est également doté d'une fixation captive et peut être orienté dans deux directions différentes par rapport au grand support, s'adaptant ainsi aux grilles de plafond étroites ou larges.

Pour installer le point d'accès avec un adaptateur pour grille de plafond, procédez comme suit :

Procedure steps

Step	Action
1	Sécurisez votre environnement de travail. Munissez-vous d'une échelle afin d'accéder facilement à la grille de plafond.
2	Déterminez un emplacement approprié sur la grille de plafond où les barres en T sont accessibles en toute sécurité et où les dalles de plafond peuvent être temporairement soulevées et retirées de l'espace de travail. Le dispositif d'adaptateur de support est conçu pour être utilisé avec les coulisseaux de la grille de la section fine et non avec ceux de la section plus épaisse, conçus pour le croisement des grandes travées. Afin de disposer d'espace pour vos mains et vos outils, utilisez des crayons ou des bâtonnets pour maintenir les dalles de plafond éloignées de la grille. Ainsi, vous bénéficiez d'une large ouverture pour fixer le support à la grille.
3	Montez le grand support sur la grille. Lors de l'installation, prêtez attention à la largeur du lattis afin de déterminer l'orientation appropriée pour l'installation du petit support à l'étape suivante.

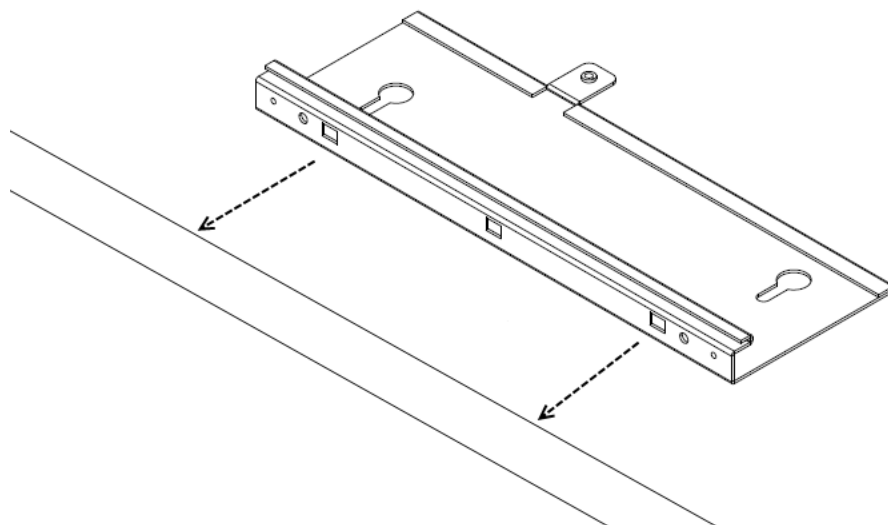

- 4 Montez le petit support croisé sur le grand support et serrez les deux éléments ensemble sur la grille. Le petit support est doté de languettes qui dans lesquelles s'insèrent les encoches du grand support. Ainsi, les deux éléments glissent simultanément et sont maintenus l'un contre l'autre. Une fois cette action effectuée, les deux supports sont resserrés sur la grille de plafond. Lorsque les deux moitiés du support coulissent correctement l'une contre l'autre, les filets du grand support

doivent s'insérer dans la fixation captive du petit support. Utilisez un tournevis pour serrer la fixation captive. Il est indispensable de fixer les deux supports de cette manière afin d'éviter qu'ils ne se détachent l'un de l'autre. Serrez solidement la vis de la fixation captive.

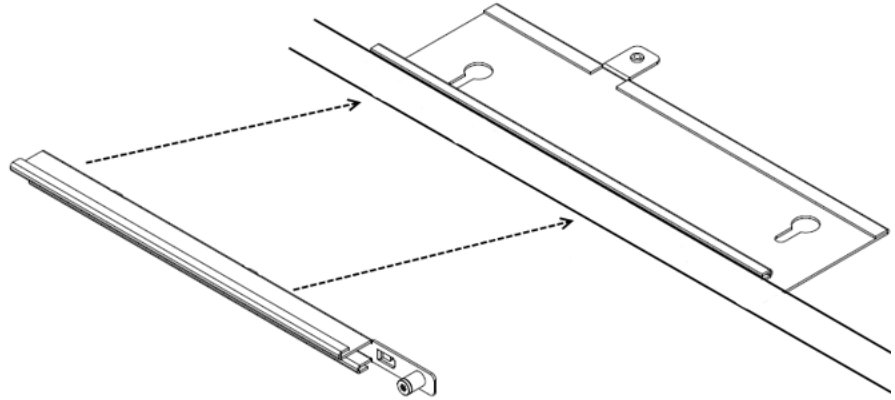

- 5 Fixez le point d'accès au support. Alignez les languettes de fixation du point d'accès avec les encoches en trous de serrure du support de la grille de plafond, puis faites glisser le point d'accès sur le dispositif de support de la grille de plafond avec soin. Si le point d'accès et le système de support sont correctement rattachés, il doit être possible d'insérer la vis captive du point d'accès dans la languette filetée du support de la grille de plafond.

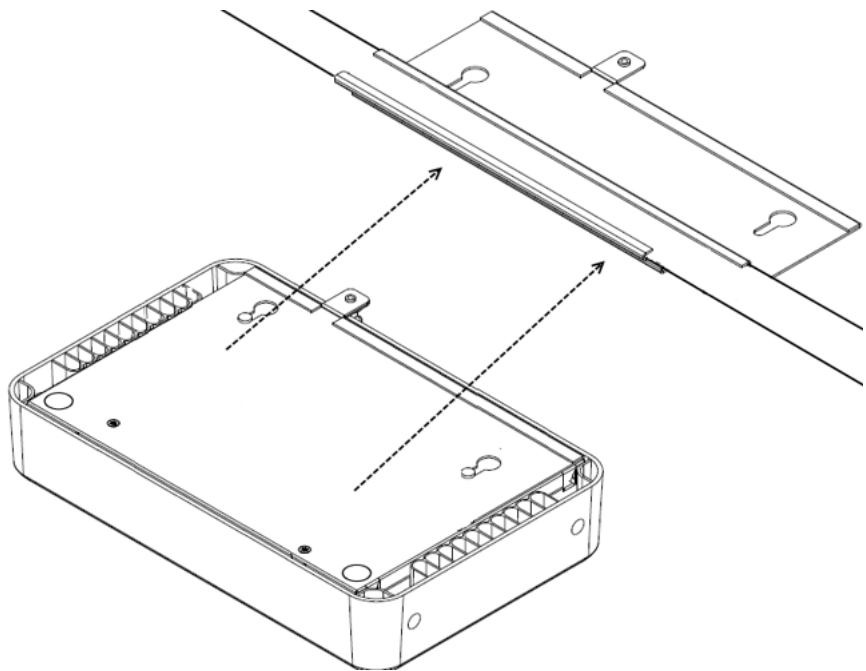

- 6 Effectuez les raccordements électriques et remettez les dalles de plafond en place.

--End--

Messages de sécurité

Ces messages ainsi que tout autre message ajouté à ce document doivent être traduits.



CAUTION

Les radios des points d'accès 8120 WLAN d'Avaya sont désactivés par défaut et peuvent uniquement être activés par un administrateur système.



WARNING

Cette situation ou condition peut provoquer des blessures.



WARNING

Tension élevée. Cette situation ou condition peut provoquer des blessures en cas d'électrocution.



WARNING

Seul le personnel de service qualifié est autorisé à effectuer l'installation. Lisez attentivement et respectez toutes les notes d'avertissement et instructions figurant sur le produit ou dans la documentation.



WARNING

Installez l'appareil en veillant à conserver une distance d'au moins 20 cm entre les éléments rayonnants et les personnes. Cet avertissement de sécurité est conforme aux limites d'exposition définies par la norme FCC relative aux fréquences radio.



WARNING

N'utilisez pas ce point d'accès à proximité de détonateurs non blindés ou dans d'autres environnements où des risques d'explosion existent, sauf si l'appareil a été modifié pour une telle utilisation par une personne qualifiée.



WARNING

Ne touchez pas et ne déplacez pas le point d'accès lorsque les antennes sont en cours de transmission ou de réception.



WARNING

Avant d'utiliser un périphérique sans fil sur un site dangereux, consultez les réglementations locales et nationales et interrogez les responsables de la sécurité du site afin de connaître les contraintes d'utilisation.

Português do Brasil

Use os seguintes procedimentos e informações ao instalar os pontos de acesso do Avaya AP 8120-R00 e AP 8120-R06.

Requisitos de cabo

As portas Ethernet no ponto de acesso não podem aceitar um cabo CAT-5 com um revestimento irregular como mostrado abaixo. O conector RJ-45 do cabo não se ajustará adequadamente ao receptáculo no ponto de acesso. Em vez disso, use um cabo CAT-5 com um revestimento uniforme.

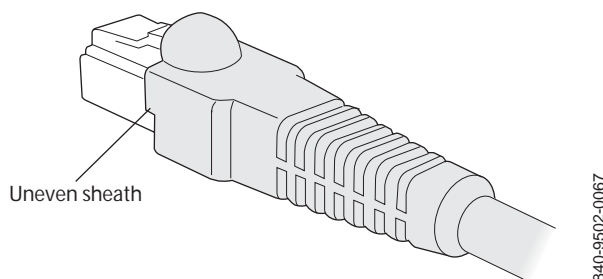

Instalando um ponto de acesso LAN sem fio em uma parede

O suporte de montagem foi projetado para usar fixadores com diâmetros de seção aparafusados entre 3,5 mm e 4,5 mm. Se os fixadores tiverem diâmetros aparafusados maiores de 3,5 mm, somente os dois furos marcados "A" poderão ser usados. Se os fixadores tiverem diâmetros menores de 3,5 mm, os furos marcados "A" e "B" poderão ser usados. Todos os fixadores de parede devem ter um diâmetro de cabeça menor de 10 mm ou não será possível instalar o suporte de montagem sobre eles.

Execute o seguinte procedimento para instalar um ponto de acesso LAN sem fio em uma parede:

Procedure steps

Step	Action
1	Localize a posição apropriada dos fixadores. Os fixadores devem ficar distantes aproximadamente 95 mm horizontalmente e 80 mm verticalmente.

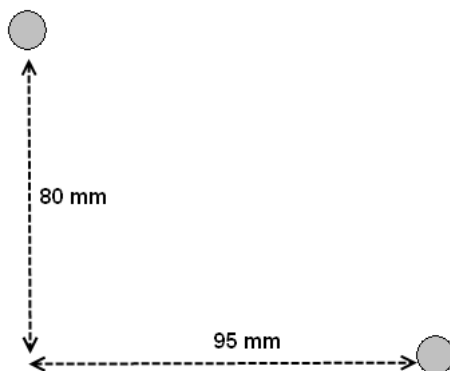

O suporte de parede foi projetado para usar um mínimo de 2 fixadores e um máximo de 4.

- 2 Instale os parafusos nos fixadores, mas não os ajuste completamente. Deixe uma folga de pelo menos 2 mm entre a cabeça do parafuso e a parede.
- 3 Deslize o suporte de parede sobre as cabeças dos parafusos e escorregue-o para a direita, voltado para a parede.

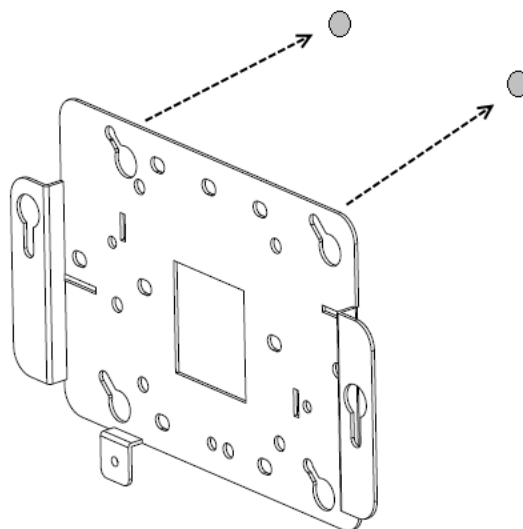

- 4 Aperte os parafusos para segurar com firmeza o suporte de montagem contra a parede.

- 5 Alinhe as presilhas de montagem na parte inferior do invólucro de metal do ponto de acesso com os slots do suporte de montagem orientados verticalmente.

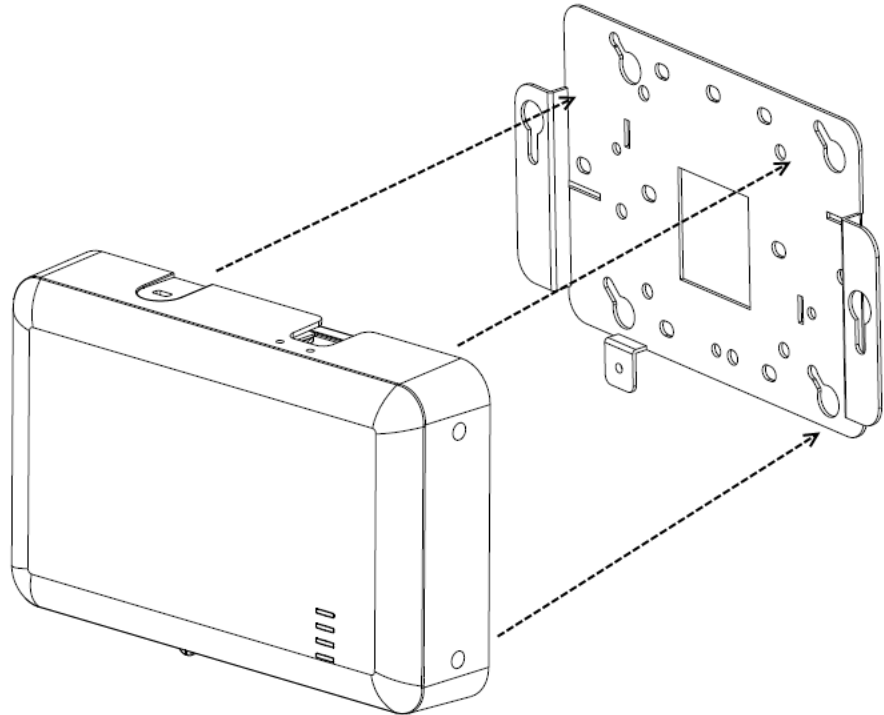

- 6 Permita que os pontos de acesso passem pelos slots, assegurando que as presilhas estejam fixadas na parte inferior do slot.
- 7 Prenda o ponto de acesso ao suporte de montagem e ajuste os parafusos.
- 8 Verifique se os pontos de acesso estão fixos no suporte e na parede.

--End--

Instalando um ponto de acesso com um adaptador de grade de teto

O adaptador de grade de teto vem com duas peças de travamento de suporte. A peça maior inclui slots moldados que se encaixam às presilhas na superfície inferior do AP (Painel de acesso) e um orifício aparafusado que se encaixa a um parafuso cativo no AP. A peça menor inclui também um prendedor cativo e pode ser orientado com relação à peça maior de duas maneiras diferentes, de acordo com grades de teto mais amplas ou mais estreitas.

Execute o seguinte procedimento para instalar o ponto de acesso com um adaptador de grade de teto:

Procedure steps

Step	Action
1	Garanta a segurança do ambiente de trabalho. Utilize uma escada que permita fácil acesso ao sistema de grade de teto.
2	Identifique um local apropriado na grade onde as barras T sejam acessíveis de forma segura e onde o revestimento do teto possa ser temporariamente suspenso e tirado da área de trabalho. O conjunto de adaptador é para ser usado com deslizadores de grade de seção mais finos, não os mais grossos, usados para atravessar grandes extensões. Para fornecer acesso às mãos e às ferramentas, use pincéis ou varetas para afastar o revestimento da grade. Isso garantirá acesso fácil para prender o suporte à grade.
3	Instale o suporte maior na grade. Durante a instalação, preste atenção à largura da tira da grade para determinar a orientação apropriada do suporte menor instalado na sequência.

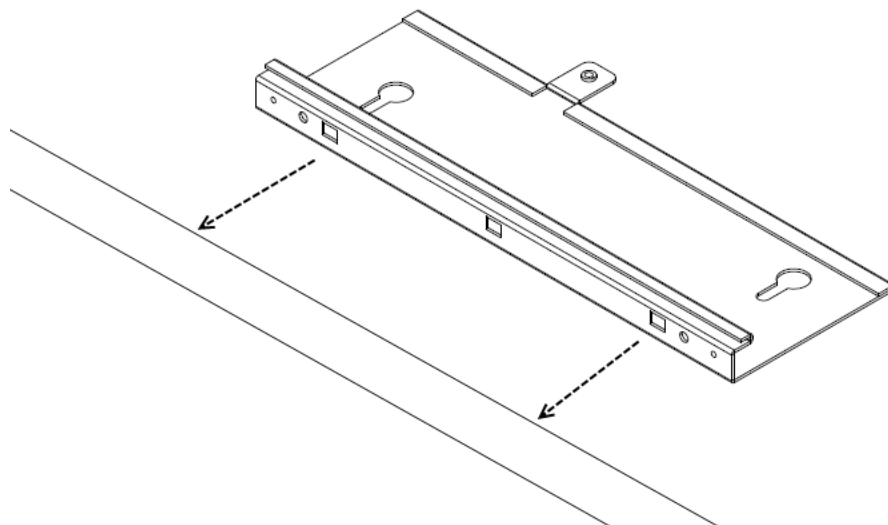

- 4 Instale o suporte de travamento menor sobre o suporte maior e acople as duas peças à grade. O suporte menor contém presilhas moldadas que prendem os slots à presilha maior. Isso permite que as duas partes deslizem juntas e se fixem uma à outra. Quando isso é feito, os dois suportes se juntam em volta da grade de teto. Quando as duas partes do suporte deslizam juntas corretamente, o prendedor cativo do suporte menor deve se ajustar aos fios do suporte maior. Use uma chave de fenda para ajustar o prendedor cativo. Prender os dois suportes

dessa maneira é essencial para evitar que se soltem. Ajuste firmemente o prendedor cativo.

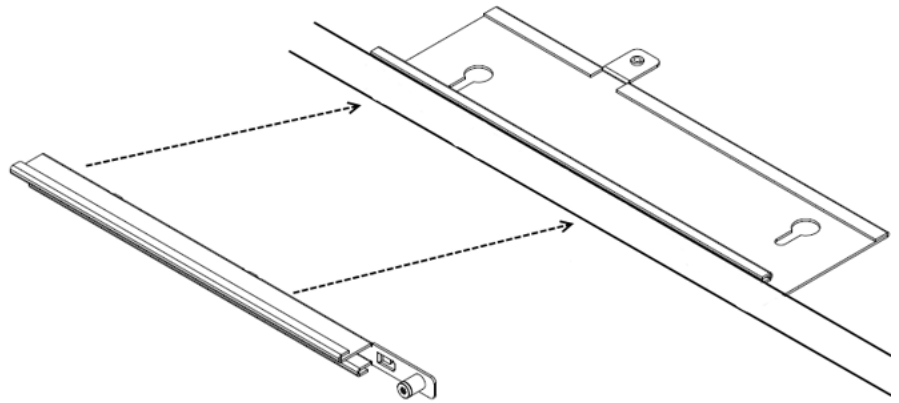

- 5 Prenda o ponto de acesso ao suporte. Alinhe as presilhas de segurança do ponto de acesso aos slots no suporte e deslize cuidadosamente o ponto de acesso no conjunto de suporte de grade de teto. Se o ponto de acesso e o conjunto de suporte forem acoplados corretamente, o parafuso cativo dos pontos de acesso deverá se ajustar à presilha fornecida no suporte da grade de teto.

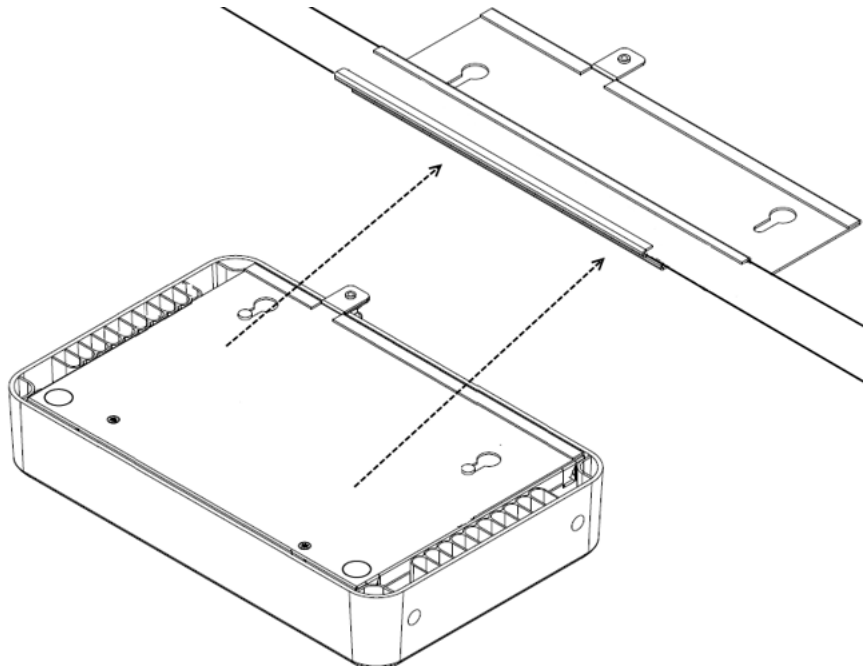

- 6 Faça as conexões elétricas e coloque o revestimento do teto no lugar.

--End--

Mensagens de segurança

Essas mensagens, e quaisquer outras, devem ser traduzidas para serem incluídas no documento.



CAUTION

Os rádios do ponto de acesso 8120 WLAN da Avaya são desativados por padrão e só podem ser ativados pelo administrador do sistema.



WARNING

Esta situação ou condição pode causar danos.



WARNING

Alta voltagem. Esta situação ou condição pode causar dano por choque elétrico.



WARNING

Somente pessoas qualificadas devem realizar a instalação. Leia e siga todas as instruções e advertências marcadas no produto ou incluídas na documentação.



WARNING

Instale este dispositivo de forma a manter um mínimo de 20 cm (7,9 polegadas) de distância entre os elementos de radiação e todas as pessoas. Este aviso de segurança está de acordo com os limites de exposição à frequência de rádio da FCC.



WARNING

Não opere o ponto de acesso próximo a pontos de sobrecarga desprotegidos nem em outro ambiente com risco de explosão a menos que o dispositivo tenha sido modificado para tal uso por pessoal qualificado.



WARNING

Não toque nem mova o ponto de acesso quando as antenas estiverem transmitindo ou recebendo.



WARNING

Antes de usar um dispositivo sem fio em um local perigoso, consulte os códigos locais, nacionais e os responsáveis pela segurança do local para obter informações sobre restrições de uso.