



CallPilot Quick Reference Card Norstar Voice Mail interface - Remote Users



Copyright © 2005–2006
Nortel Networks, All rights reserved
NN40090-105 01.01

Initializing your mailbox

You must initialize your mailbox to receive and store messages.

1. Dial the CallPilot system telephone number.
The CallPilot system number is: _____.
2. Dial the CallPilot extension, then enter your mailbox number.
3. Enter 0 0 0 0 (the temporary password) and press #.
4. Enter a new password from four to eight digits long that does not start with zero, and press #.
5. Reenter your new password and press #.
6. At the tone, record your name in the company directory.
7. Press # to end the recording.
8. Press # to accept the recording.
9. Replace the handset to end the session.

Now you are ready to record your personal mailbox greetings and use the CallPilot features described in this card.

Note: If you do not record a personal greeting, your Company Directory name plays to callers.

For detailed information about using the Norstar Voice Mail interface, refer to the *CallPilot Reference Guide*.

Accessing your mailbox

From your telephone:

1. Enter the CallPilot system number and then enter the CallPilot extension.
2. Enter your mailbox number and password and press #.
3. Follow the voice prompts and press the dialpad keys for the features you want to use.

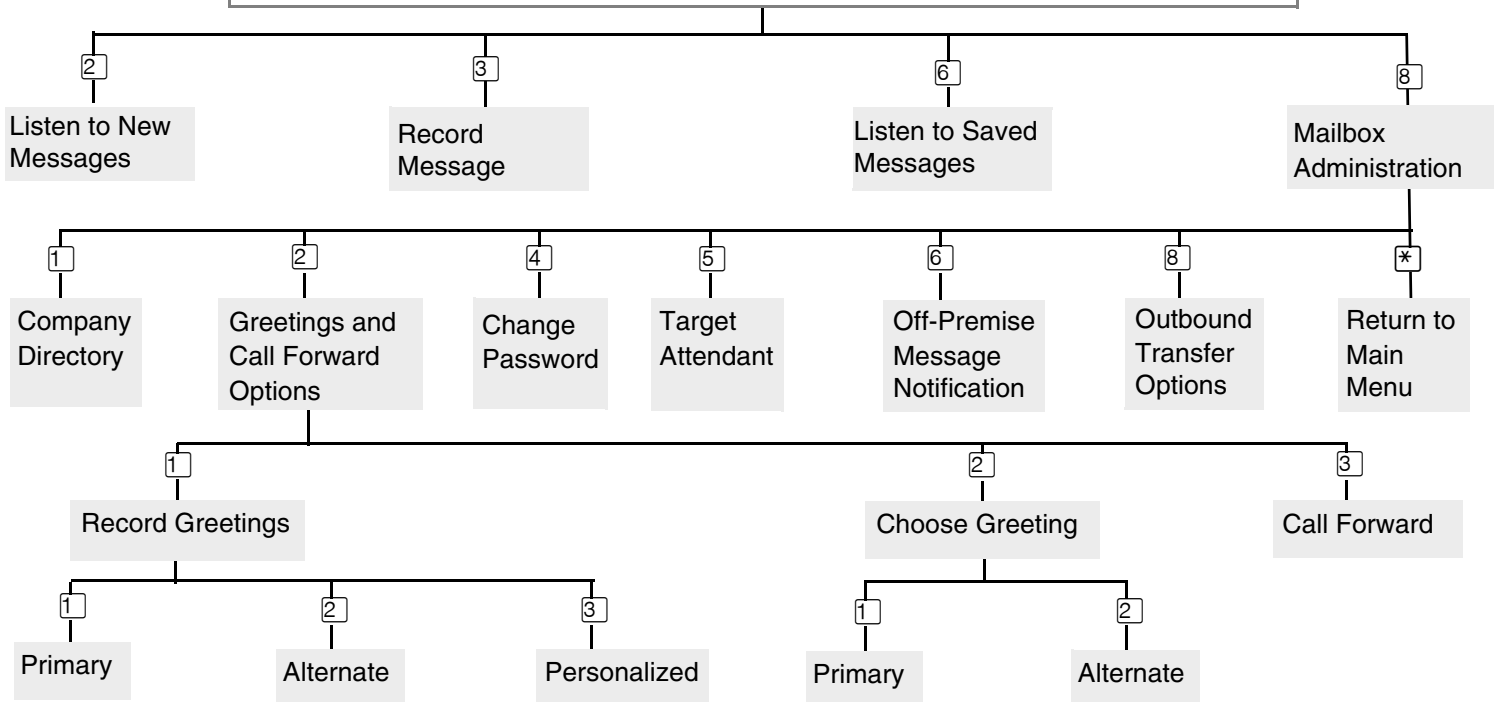

Playing messages

From your telephone:

1. Enter the CallPilot system number and then enter the CallPilot extension.
2. Enter your mailbox number and password and press [#].
3. Follow the voice prompts and press the dialpad keys for the features you want to use. Press 2 to listen to new messages, or 6 to listen to saved messages.

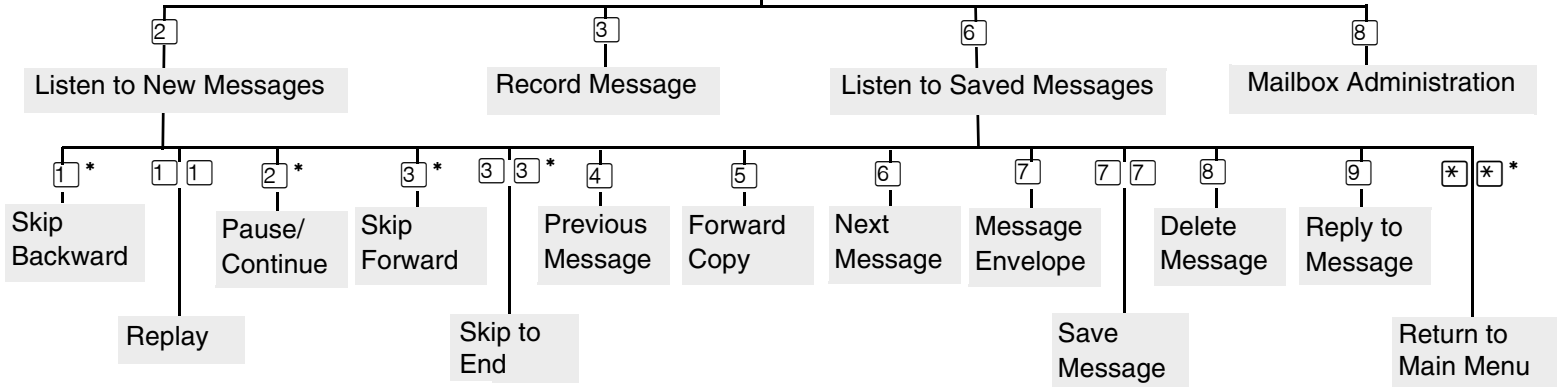

* Applies only when message is playing.

To retrieve a deleted message

You can retrieve a deleted message if you are still in a CallPilot session. A deleted message remains in your mailbox until you end your current CallPilot session. If you have listened to all your new and saved messages, you can play and retrieve your deleted messages.

Press 2 to listen to your deleted messages. When you play your deleted message, you have the option to save it. If you end the session without saving the deleted message, it is permanently deleted from your mailbox.

Sending messages

From your telephone:

1. Enter the CallPilot system number and then enter the CallPilot extension.
2. Enter your mailbox number and password and press [#].
3. Follow the voice prompts and press the dialpad keys for the features you want to use. Press 3 to compose a message.

