

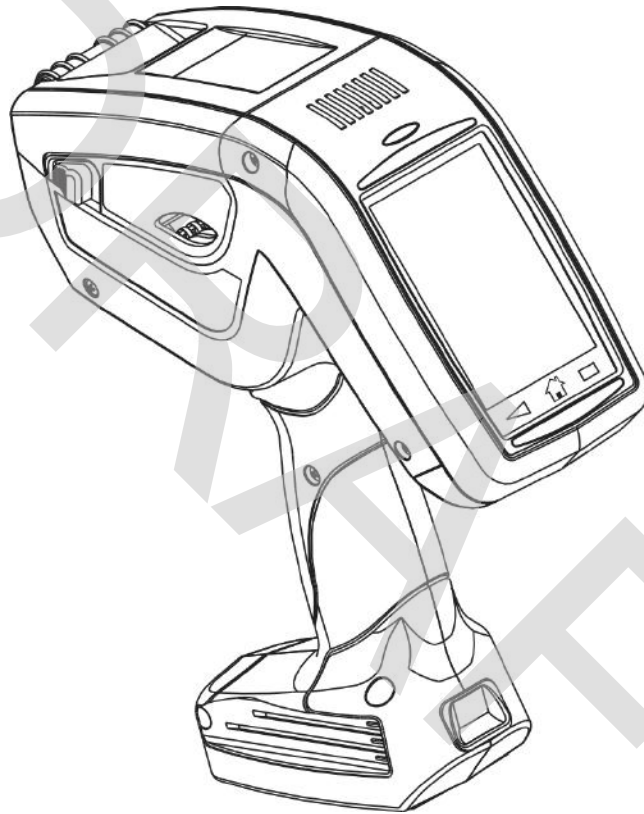

6059 Printer Operator's Handbook



Each product and program carries a respective written warranty, the only warranty on which the customer can rely. Avery Dennison Corp. reserves the right to make changes in the product, the programs, and their availability at any time and without notice. Although Avery Dennison Corp. has made every effort to provide complete and accurate information in this manual, Avery Dennison Corp. shall not be liable for any omissions or inaccuracies. Any update will be incorporated in a later edition of this manual.

©2019 Avery Dennison Corp. All rights reserved. No part of this publication may be reproduced, transmitted, stored in a retrieval system, or translated into any language in any form by any means, without the prior written permission of Avery Dennison.

DRAFT

Trademarks

Avery Dennison® and Pathfinder® are registered trademarks of Avery Dennison Corporation. Android is a trademark of Google LLC.



Avery Dennison
170 Monarch Lane
Miamisburg, OH 45342

Outside the U.S., send batteries to:
EMEA, 4 Awberry Court
Croxley Business Park, Hatters
Lane, Watford, WD18 8PD

TABLE OF CONTENTS

GETTING STARTED	1-1
Audience	1-1
Printer Overview.....	1-1
Charging the Battery.....	1-2
Replacing the Battery	1-3
Battery Safety Information.....	1-3
Using the Keypad and Display	1-4
Display Icons	1-4
LOADING SUPPLIES	2-1
Loading for Non-Peel Mode.....	2-4
Loading for Peel Mode.....	2-6
PRINTING LABELS	3-1
Printing.....	3-1
About RFID Supplies	3-1
Adjusting the Print Contrast.....	3-1
Adjust Print Position	3-1
Select Sensor Type	3-1
Adjusting the Display Backlight.....	3-2
Power Management?	3-2
Scanning Bar Codes	3-3
Certification Note	3-3
CARE & MAINTENANCE	4-1
Storing the Printer	4-1
Clearing Supply Jams	4-1
Cleaning	4-1
Cleaning the Printhead	4-2
Cleaning the Platen, Liner Drive, and Pinch Rollers	4-2
Cleaning the Black Mark Sensor.....	4-3
Cleaning the Display Screen and Scanner Window.....	4-4
TROUBLESHOOTING	5-1
Checking the Software Version	5-2
Printing a Test Label	5-2
Error Codes	5-3
Technical Support	5-4

SPECIFICATIONS & ACCESSORIES.....A-1
SpecificationsA-1
AccessoriesA-2

DRAFT

GETTING STARTED

1

The Avery Dennison® Pathfinder® 6059 prints, scans, and collects data. The printer operates in peel mode or non-peel mode. The printer uses the Android™ 7.1 platform. Your printer may include the optional RFID module, which the printer uses to encode (program) an RFID (Radio Frequency Identification) inlay while printing. RFID inlays contain an embedded programmable microchip and an antenna.

This manual describes how to insert a battery, load supplies, and clean the printer. It also includes basic troubleshooting information. Your printer may also contain a custom application. Avery Dennison writes custom applications. Contact your Avery Dennison Representative for more information.

Audience

This manual is for the operator who scans or enters data to print and apply labels. For advanced printer configuration information, refer to the *System Administrator's Guide*. To create a format for the printer, refer to the *LNT Programmer's Manual or the Label Design Utility*.

Review the *Safety Document* included with your printer and the Regulatory information found on our web site. Keep the box and packaging materials in case the printer ever needs repair.

Printer Overview

User touch parts are yellow.

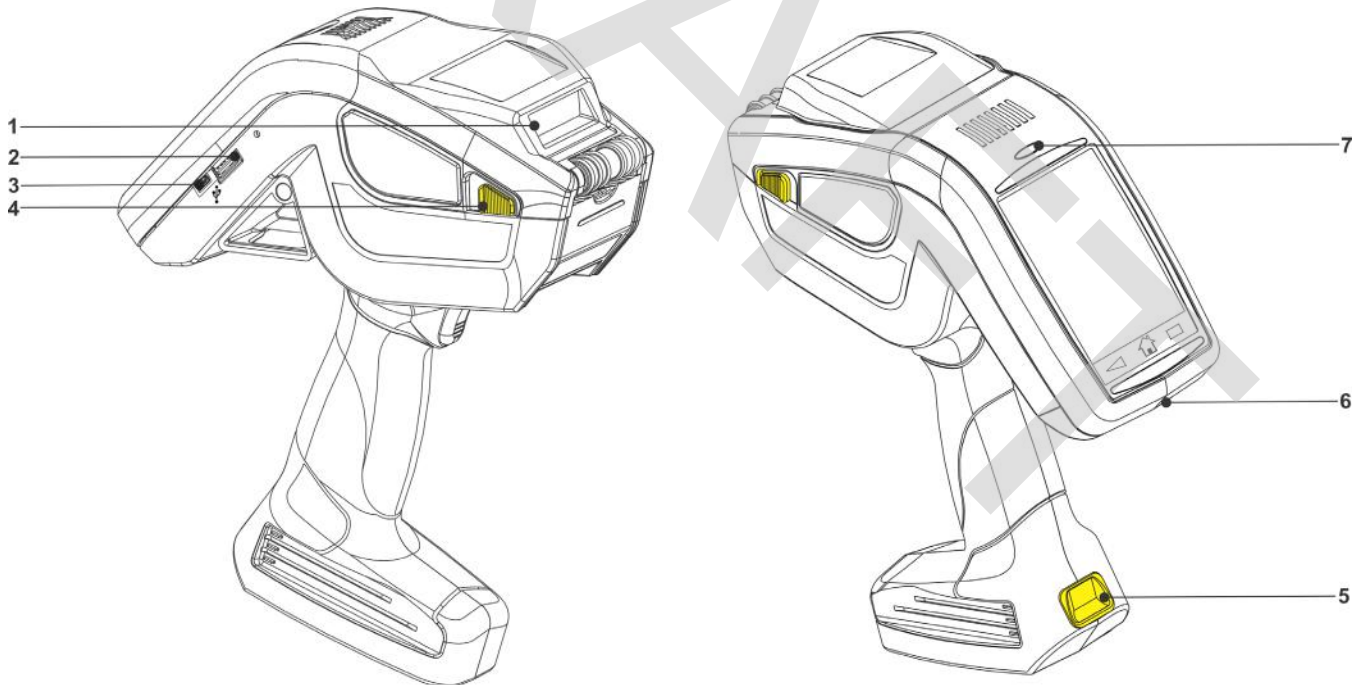

1	Scanner	5	Battery Release
2	USB Type A host	6	Power Button
3	Mini-B Device	7	Scanner LED
4	Latch Button		

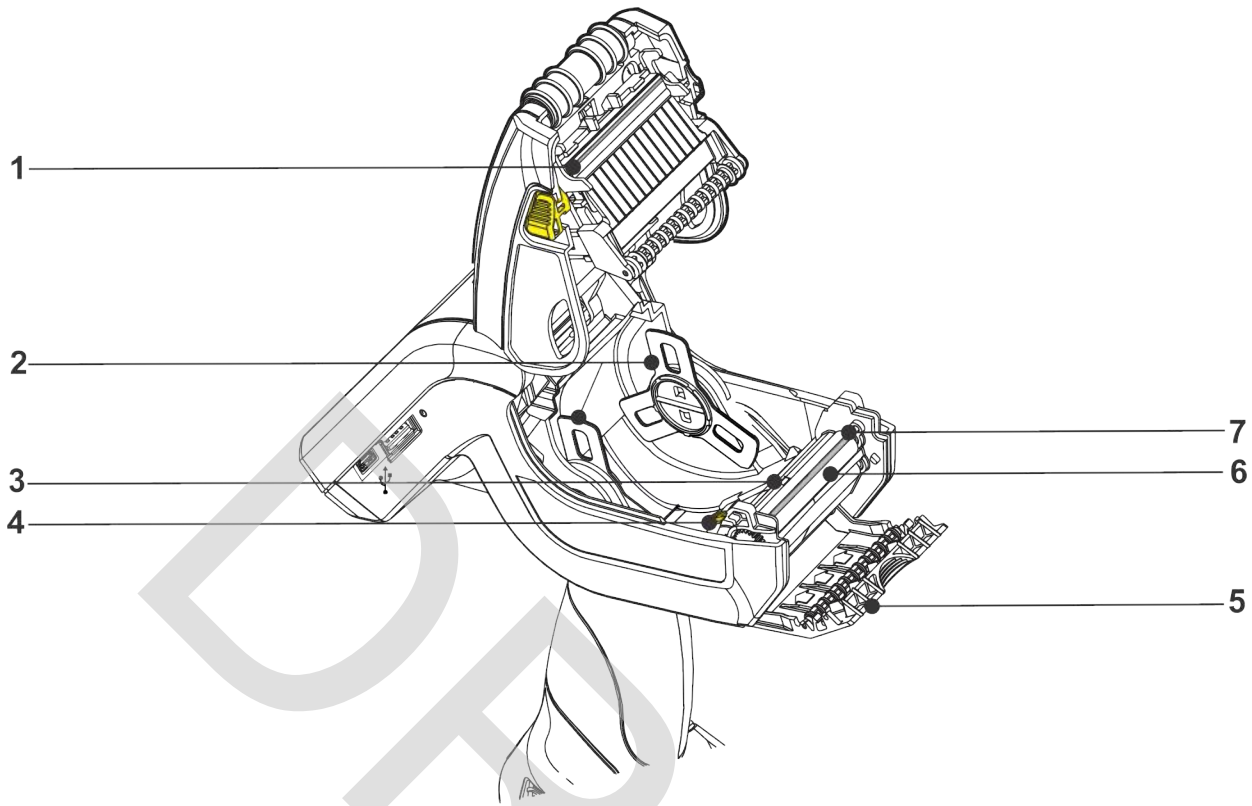

1	Printhead	5	Label Deflector
2	Supply Holder Tabs	6	Platen Roller (black rubber)
3	Black Mark Sensor	7	Peel Bar (metal)
4	Supply Lock Tab		

Charging the Battery

The printer uses a 7.4V lithium-ion battery. The printer also uses a backup battery, which is not user replaceable. The backup battery keeps the printer's system settings.

Charge the battery when you receive the printer, even if you do not use the printer right away.

Warning: Do not substitute batteries.
 Charge the battery using one of the Monarch® chargers listed in Appendix A, "[Specifications & Accessories](#)."
 The battery might explode if placed on a different charger.

Charging time is approximately 1 – 3 hours. Refer to the documentation provided with the chargers for more information.

Replacing the Battery

To change the battery:

1. Hold the printer upright with one hand and press the battery release button on the handle with your other hand.
2. The battery compartment door opens slightly. Use your finger to open the door.
3. Remove the battery.
4. Insert a new battery (label side up) into the compartment (connector end last).

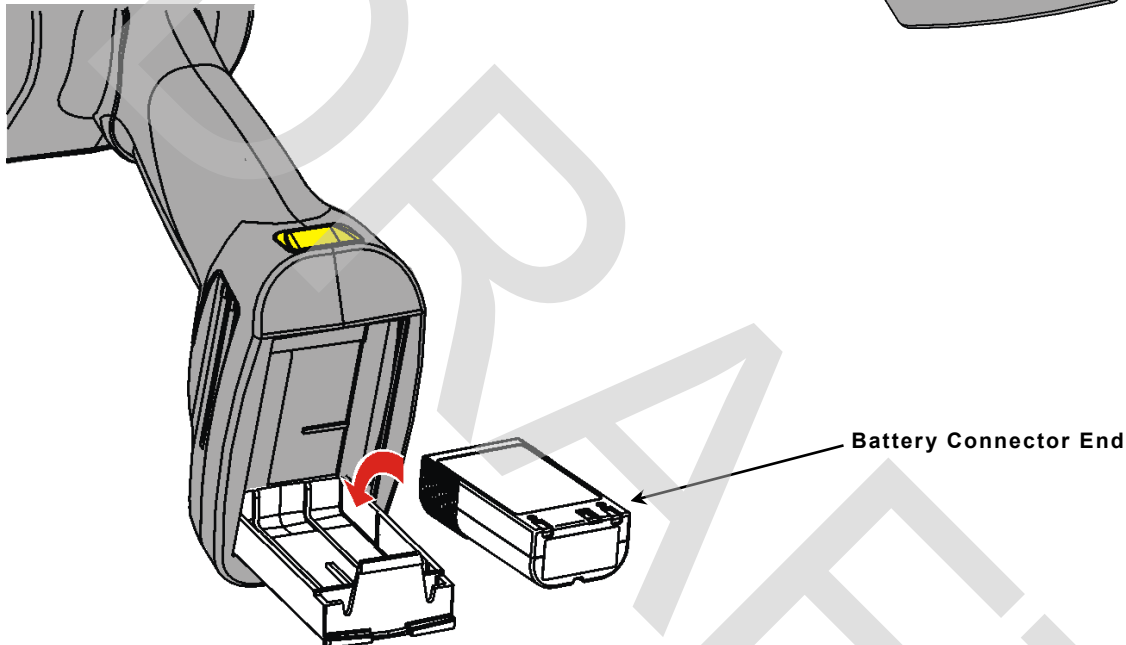
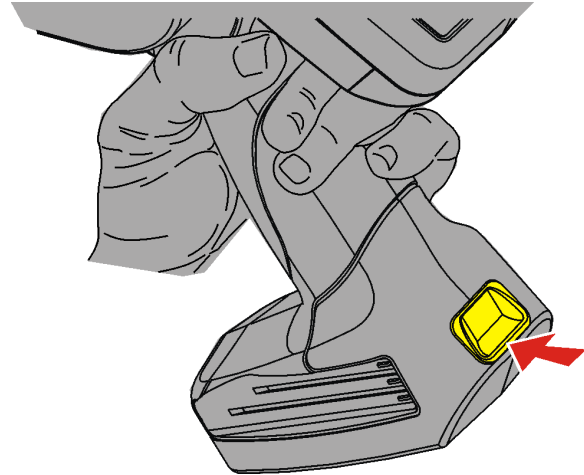

5. Close the compartment door until it clicks into place.

Battery Safety Information

See Appendix A, "[Specifications & Accessories](#)" for the replacement battery part number and recommended operating/storage temperatures for the battery.

- ◆ Charge the battery before using it. For optimal battery life, charge the battery within three months of receipt.

Warning: Do not substitute batteries. Charge the battery using one of the Monarch® chargers listed in Appendix A, "[Specifications & Accessories](#)." The battery might explode if placed on a different charger.

- ◆ The printer uses battery power even when it is not printing. Turn off the printer when it is not in use. Take the battery out of the printer when storing the printer for a month or longer. The battery should be charged before long-term storage or after the battery has been exhausted from a printing session. Frequent charging actually prolongs battery life and has no negative effects such as memory loss.

Warning: Do not disassemble, short-circuit, heat above 80°C, or incinerate the battery; it may explode.



- ◆ **Do not** let the battery come into contact with metal objects.
- ◆ **Do not** use a battery with a cracked case.
- ◆ **Do not** get the battery wet.
- ◆ It is normal for battery capacity to decrease up to 20% over the first 300 cycles of use.

Recycling Information – Do not throw in the trash. Recycle according to your local regulations. The Rechargeable Battery Recycling Corporation (RBRC®) is a non-profit organization created to promote recycling of rechargeable batteries. For more information about how to recycle batteries in your area, visit www.rbrc.org. Batteries can also be returned postage-paid to:

Avery Dennison ERC
200 Monarch Lane
Door #39
Miamisburg, OH 45342

Using the Keypad and Display

The printer has a touch screen display with three standard task buttons:

Key	Description
	Back - returns to the previous screen/menu?
	Home – user sees the Home screen.
	Overview – opens thumbnails of recently used applications, which allows you to switch tasks.

Display Icons

The status bar displays the battery voltage, connection type, wireless signal strength, etc.

There's no need to show these icons as they are so common in smart devices, etc.

LOADING SUPPLIES

The printer uses two types of supplies:

- ◆ Labels
- ◆ Tags <- Is this true? What about receipt paper?

The printer has two print modes.

- ◆ Peel mode removes the backing paper from the supplies as it prints the labels. This mode allows you to apply the label immediately. It is only for labels. Press the trigger to print a label or the next label prints automatically when the previous one is removed.
- ◆ Non-Peel mode does not remove the backing paper. It is for supplies printed in a continuous strip.

When you load a new roll of supplies, check the battery's power, if it is low, switch to a fully charged battery. To load supplies:

1. Turn on the printer.

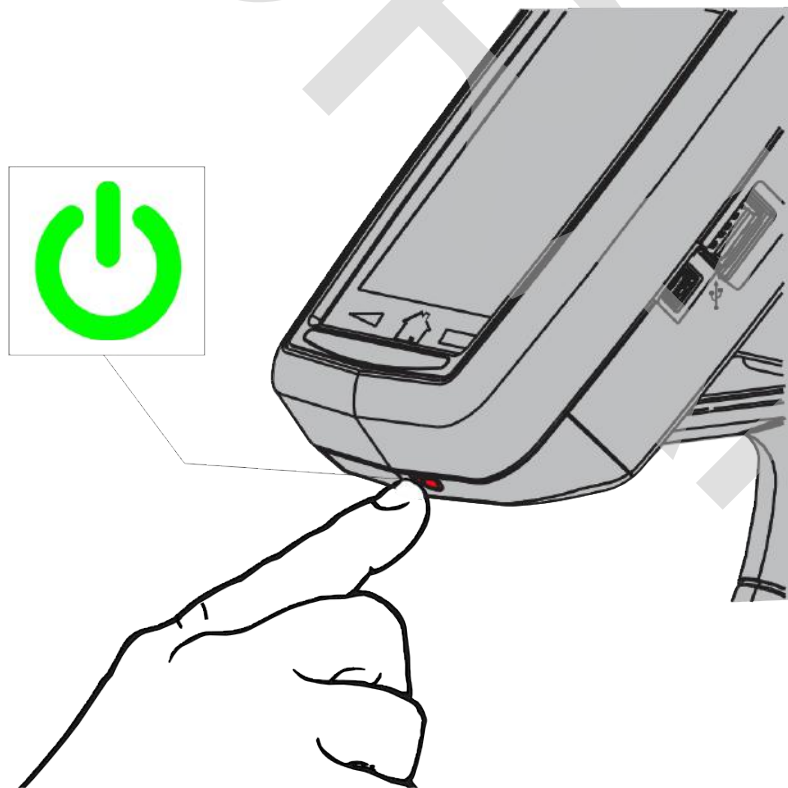

2. Push the latch buttons to open the supply cover.

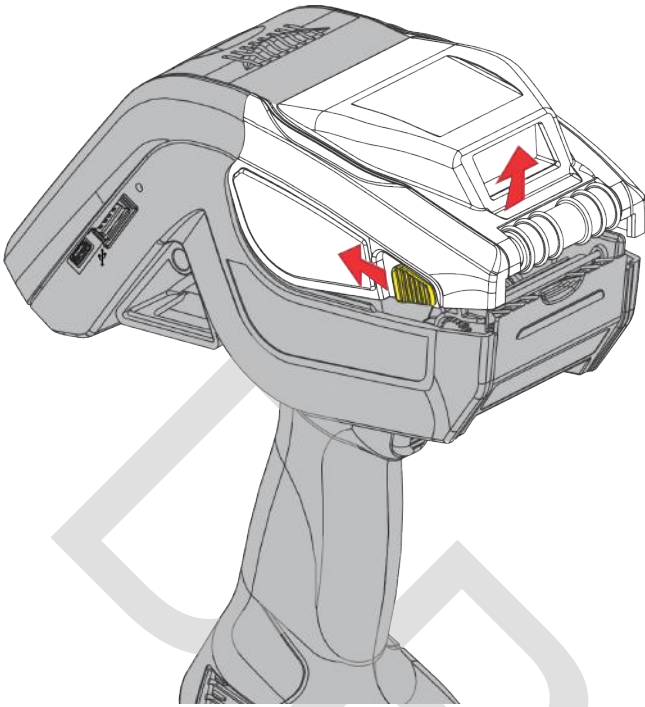

3. Spread the supply holder tabs apart with one hand so it adjusts to the size of your supply roll.
4. Press the supply lock tab all the way down (towards the inside of the printer) to lock the supply holder at 1.2". Adjust it to the middle position to lock the supply holder at 1.5". Adjust it all the way up (towards the opening of the printer) to lock the supply holder at 2.0".

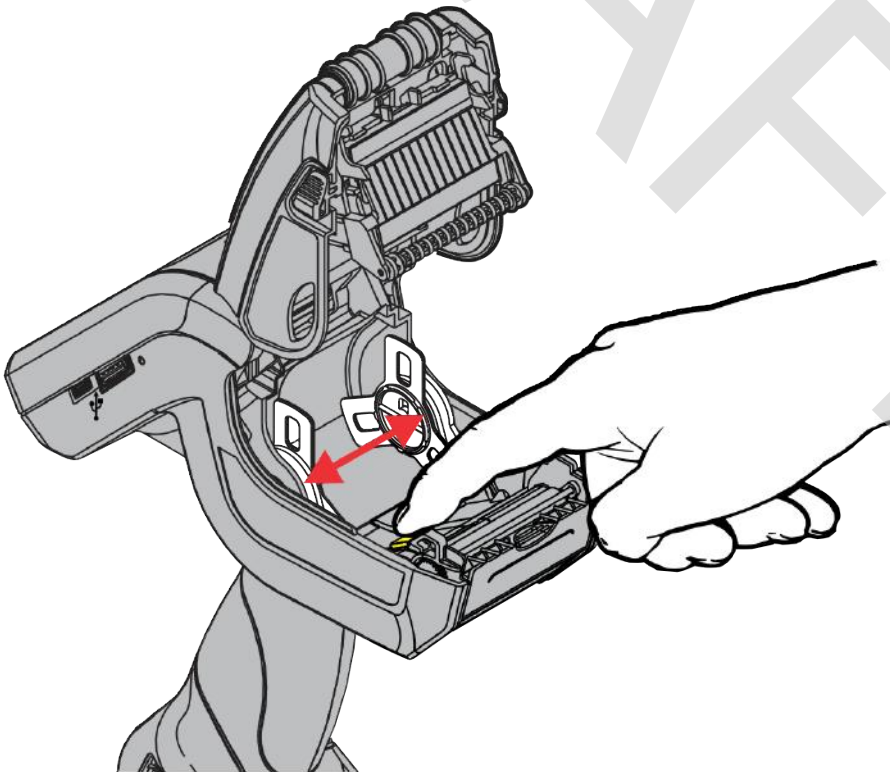

5. Place the supply roll in the supply holder so the supply unrolls from the bottom.

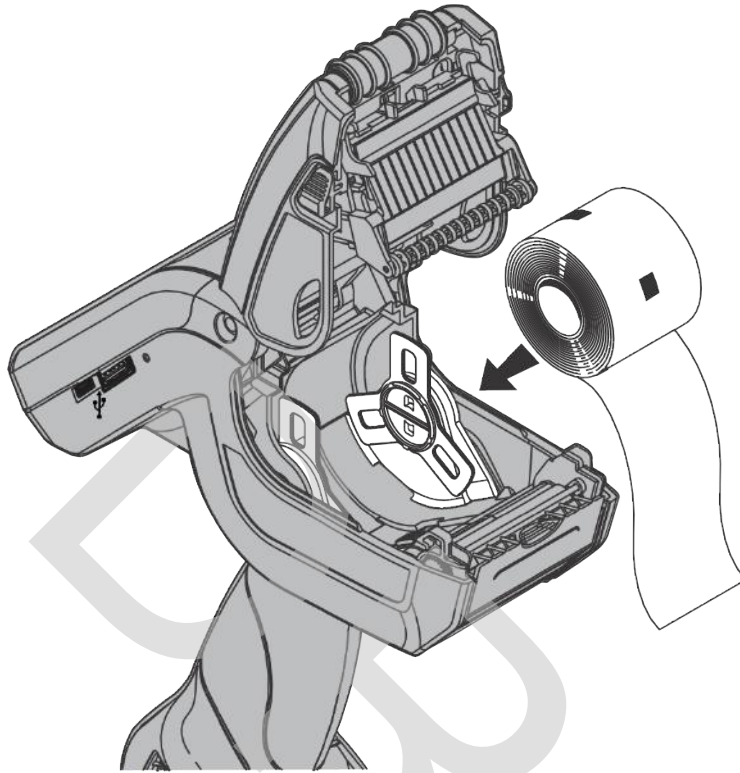

6. Continue loading supply for the printing mode you need: peel or non-peel.

Loading for Non-Peel Mode

Non-Peel mode does not remove the backing paper – supplies are printed in a continuous strip.

1. Feed the supply **over** the platen roller, peel bar, and label deflector.

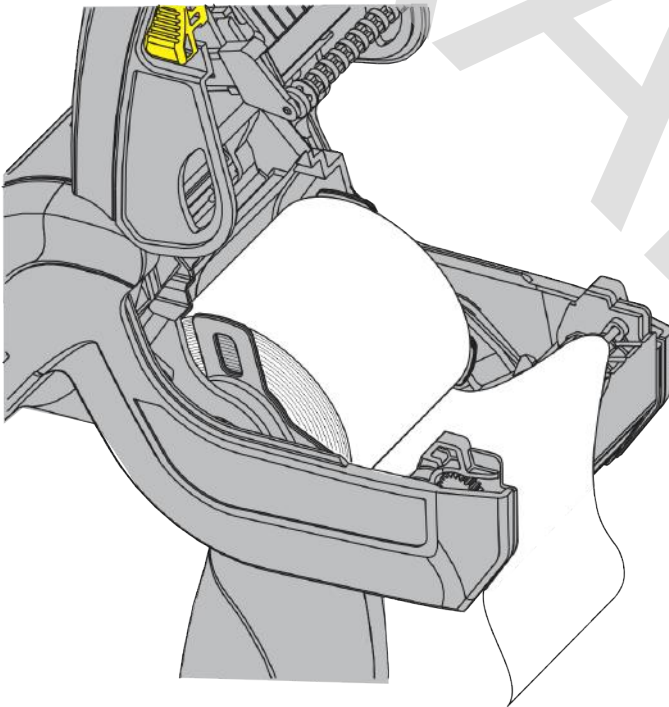
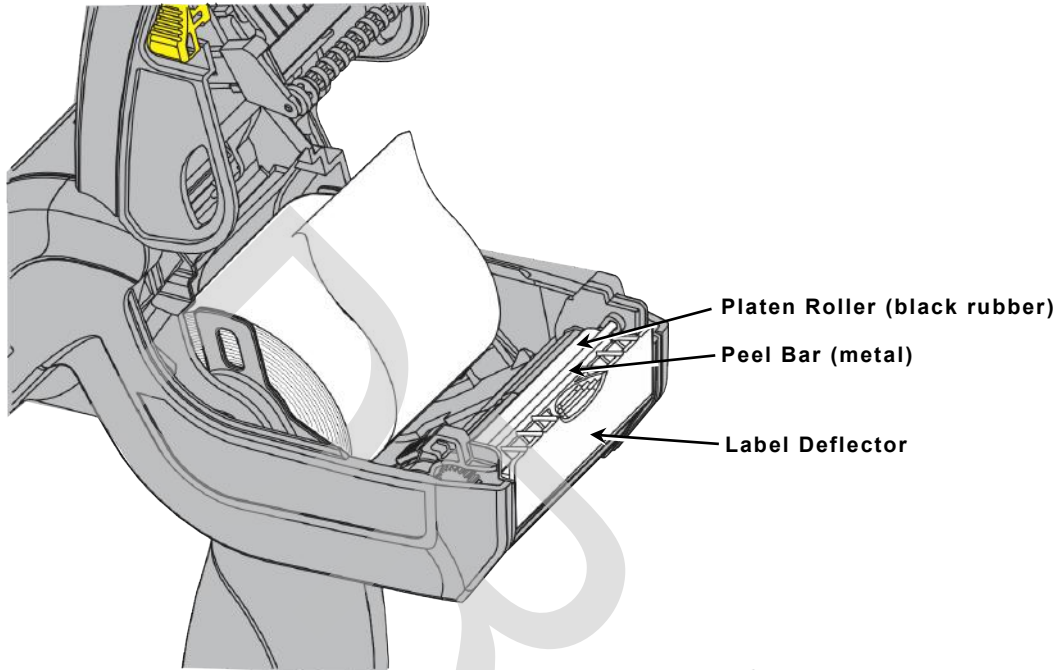

2. Close the supply cover.

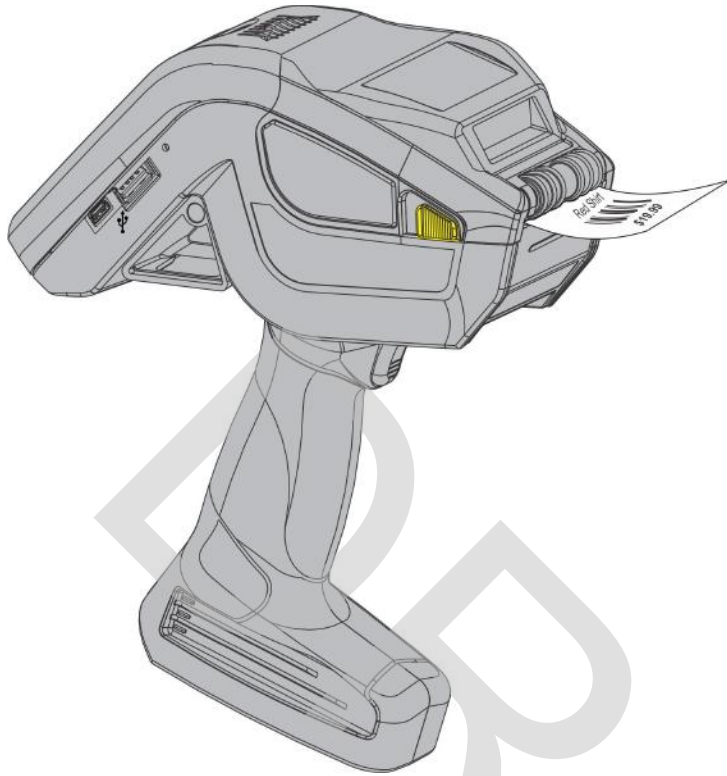

3. Where is calibrate routine and is it needed? What button advances supply?

Loading for Peel Mode

Peel mode removes the backing paper from the supplies while printing. Apply the label with steady pressure (not force).

1. Peel and discard the first four inches of labels from the backing paper.
2. Hold the printer upright and gently push down on the label deflector.

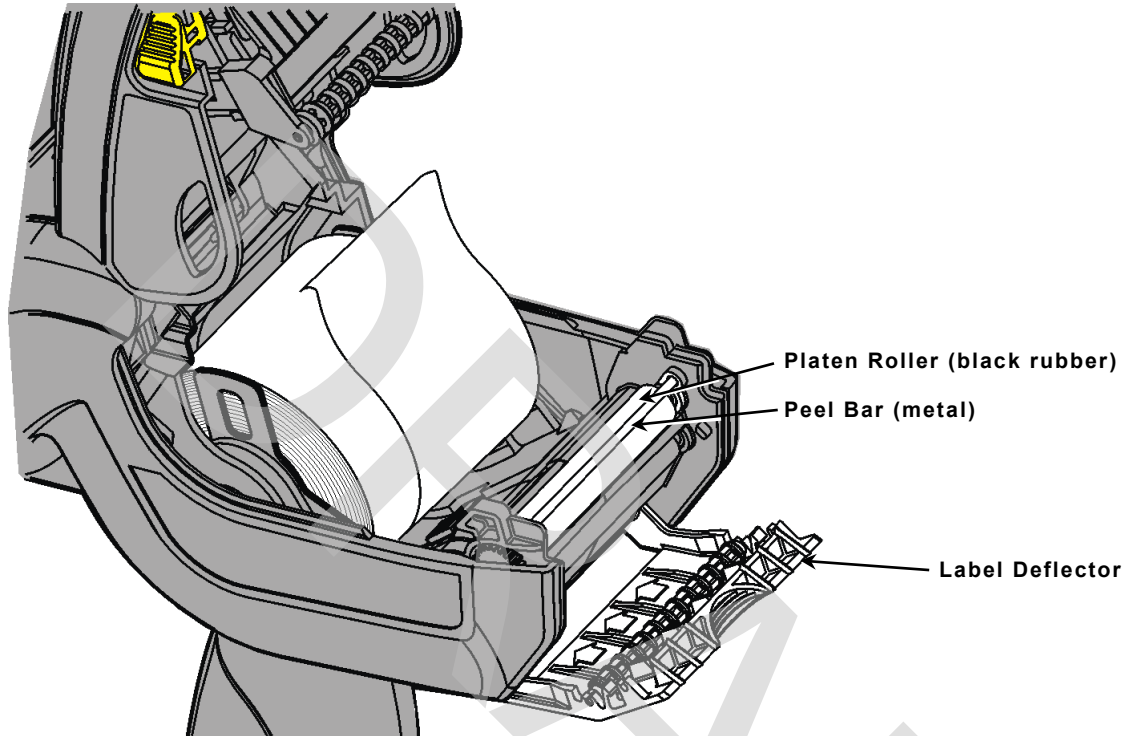

3. Feed the backing paper **over** the peel bar and through the slot at the base of the label deflector.

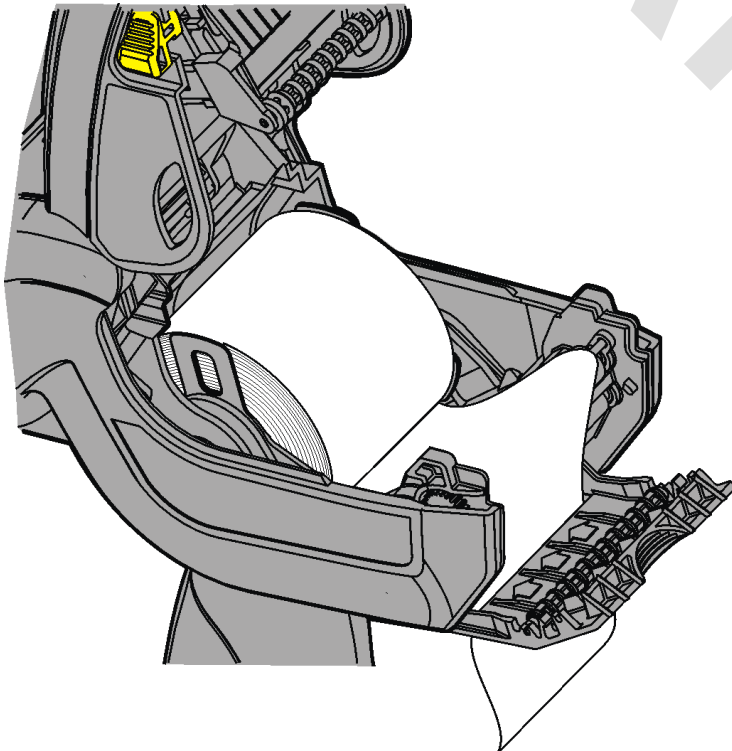

4. Close the supply cover.
5. Hold the backing paper and push up the label deflector until it snaps into place.

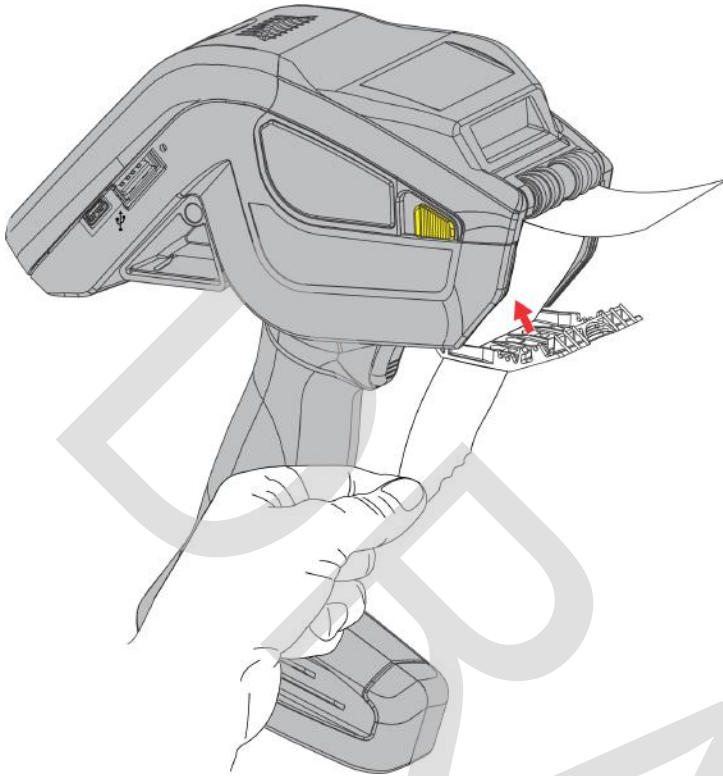

6. Where is calibrate routine and is it needed? What button advances supply?

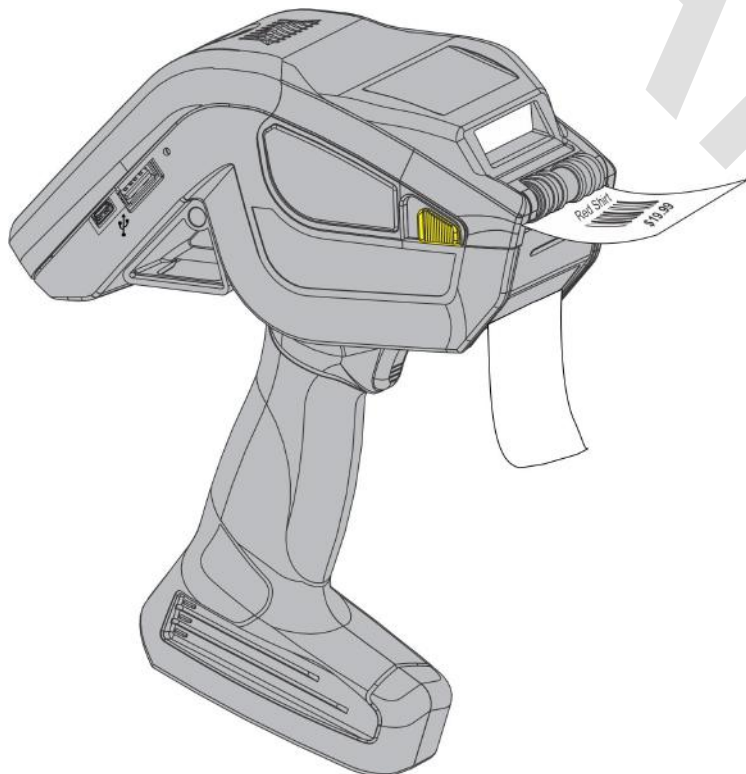

DRAFT

This chapter explains how to

- ◆ print a label
- ◆ **adjust the contrast**
- ◆ scan a barcode.

Note: Your printer may contain a custom application.

Printing

When and how you print depends on your printer's application. It may print

- ◆ only after you press a certain key
- ◆ automatically as soon as you squeeze the trigger
- ◆ automatically with no input from you
- ◆ one label or a strip of labels.

Always start printing with a fully charged battery.

About RFID Supplies



RFID Supplies can be damaged by static electricity. Ground yourself by touching metal before handling RFID the supplies.

Note: Printing over the RFID inlay causes printing irregularity and may impact bar code print quality.

On 6059, will users need to enter settings to program the inlay – such as encode position? Where will those settings come from? RFID Printer Setup Utility on our website?

Adjusting the Print Contrast

Will this be a user function or only at Sys Admin level?

Using the correct print contrast setting is important because it affects how well your bar codes scan and how long your printhead lasts. Solid black print cannot exceed 30% of any given square inch of the supply.

Adjust Print Position

Will this be a user function or only at Sys Admin level?

Select Sensor Type

Will this be a user function or only at Sys Admin level?

Adjusting the Display Backlight

Will this be a user function or only at Sys Admin level?

Power Management?

Will this be a user function or only at Sys Admin level?

DRAFT

Scanning Bar Codes

Your printer has a built-in two dimensional scanner.

To scan a bar code:

1. Point the scanner at a slight angle, approximately 4 – 8 inches from the bar code symbol.
2. Press the trigger or other key specified by your System Administrator.

Caution: Do not stare into the beam.

The scanner LED is above the display.

Scanner LED	Description
Green	Successful scan.
Yellow	Unsuccessful scan.

If the bar code does not scan:

- ◆ Change the scanner's angle slightly and try again.
- ◆ Clean the scanner window. See "Cleaning" in Chapter 5 for more information.
- ◆ Move the scanner 4 – 8 inches away from the bar code. Adjust this distance as needed to find the correct distance.
- ◆ Try scanning another bar code that you have scanned successfully. If that scan is successful, the scanning problem is with the bar code.
- ◆ Move to a more dimly lit area.
- ◆ Ensure there are no voids (streaks) in the bar code symbol.

If the scan is still unsuccessful, ask your System Administrator to perform a scanner test.

Certification Note

This product is certified to be a Class II laser product with the United States DHHS Center for Devices and Radiological Health and complies with 21CFR1040.10 and 1040.11 except for deviations pursuant to Laser Notice No. 50, dated July 26, 2001, The scanner emits less than a 2.0 milliwatt beam of laser light from the scanning window. Laser light in excess of Class I limits must be inside a protective cover. No maintenance is required to keep this product in compliance with EN 60825, IEC60825, and DHHS Regulation 21, Subchapter J. No controls are provided for operation or maintenance.

Caution: Use of controls, adjustments or performance of procedures other than those specified herein may result in hazardous laser light exposure.

Class II laser scanners use a low power, visible light diode. As with any very bright light source, the user should avoid staring directly into the light beam. Momentary exposure to a Class II laser is not known to be harmful.

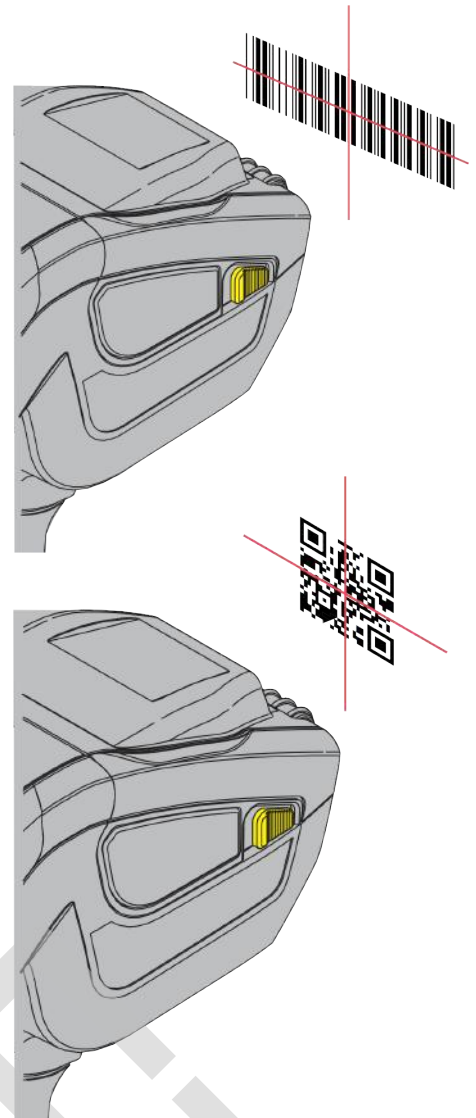

DRAFT

This chapter tells you how to

- ◆ store the printer
- ◆ clear supply jams
- ◆ clean the printhead, platen roller, sensors, and scanner window.

Storing the Printer

The recommended storage temperature is listed in Appendix A. **Do not** store the printer in or near

- ◆ magnetic fields
- ◆ wet, damp, dirty, or dusty areas
- ◆ areas of intense vibration or shock.

Clearing Supply Jams

To clear a supply jam:

1. Turn off the printer and completely open the supply cover.
2. Open the label deflector by gently pushing down on the label deflector.
3. Remove the supplies.
4. Carefully remove any jammed supply. **Do not** pull the jammed supply out through the front of the label deflector. **Do not** use sharp objects to remove jammed supplies.
5. Clean any adhesive build-up.
6. Reload the supplies, close the supply cover, and close the label deflector.

Cleaning

Do not use sharp objects or household cleaners to clean the printer. Clean the printhead, platen roller, and black mark sensor:

- ◆ when there is any adhesive build-up in the supply path.
- ◆ after using 7-10 rolls of supplies.
- ◆ when printing in extreme temperatures, humid conditions, or a dirty environment.
- ◆ after clearing a supply jam.
- ◆ if there are voids or streaking in the print as shown.



Voids



Streaks

Cleaning the Printhead

The following actions may damage the printhead:

- ◆ **Do not** use silicone to clean or lubricate.
- ◆ **Do not** use sharp objects to remove adhesive or label particles from the printhead area.
- ◆ **Do not** touch the printhead with your fingers.

To clean the printhead:

1. Turn off the printer.
2. Open the supply cover and remove the supplies.
3. Check the supply holder for adhesive buildup and clean it if necessary.

Note: Ground yourself by touching a metal object (not the printer) before cleaning the printhead. Grounding prevents electrostatic discharge, which may damage the printhead.

4. Clean the printhead area of all adhesive and label pieces using a Cleaning Pen or a soft cloth moistened with isopropyl alcohol. Let the printhead dry.

5. Reload the supply roll and close the supply cover.

6. Turn on the printer.

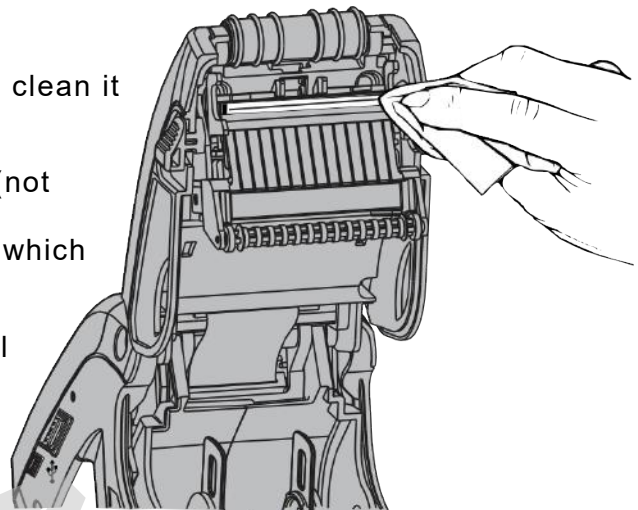

Cleaning the Platen, Liner Drive, and Pinch Rollers

Clean these rollers when you see adhesive build-up or when a label is wrapped around them.

1. Turn off the printer, open the supply cover, and open the label deflector.
2. Remove the supplies.

3. Hold the printer upright and gently push down on the label deflector. It may be stiff.

4. Use a dry, soft-bristle brush, such as a toothbrush, to clean the rollers.

If the brush does not remove all adhesive, moisten a cotton swab with isopropyl alcohol and run the cotton swab across the roller. Wait a few minutes for the printer to dry.

5. Reload the supplies, close the label deflector and supply cover.
6. Turn on the printer.

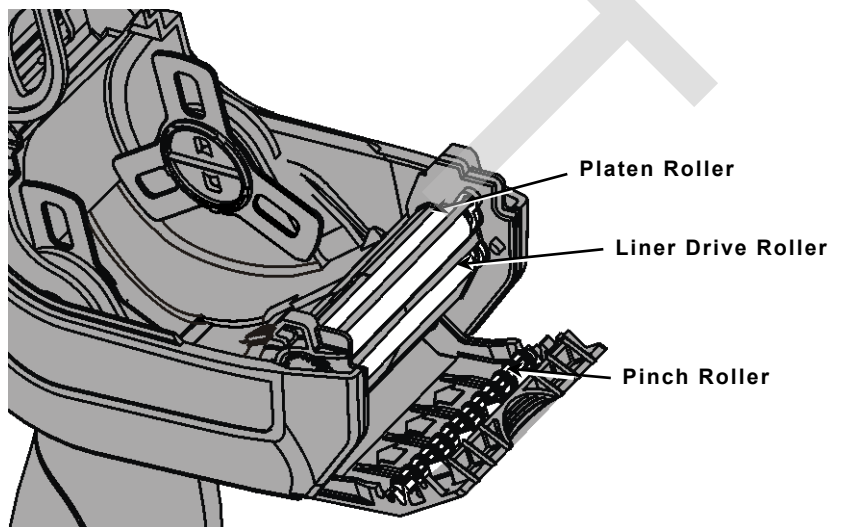

Cleaning the Supply Sensors

To clean the supply sensors:

1. Turn off the printer and open the supply cover.
2. Remove the supplies.
3. Open the label deflector by gently pushing down on the label deflector.
4. Clean the black mark sensor and on-demand sensor with a dry cotton swab.

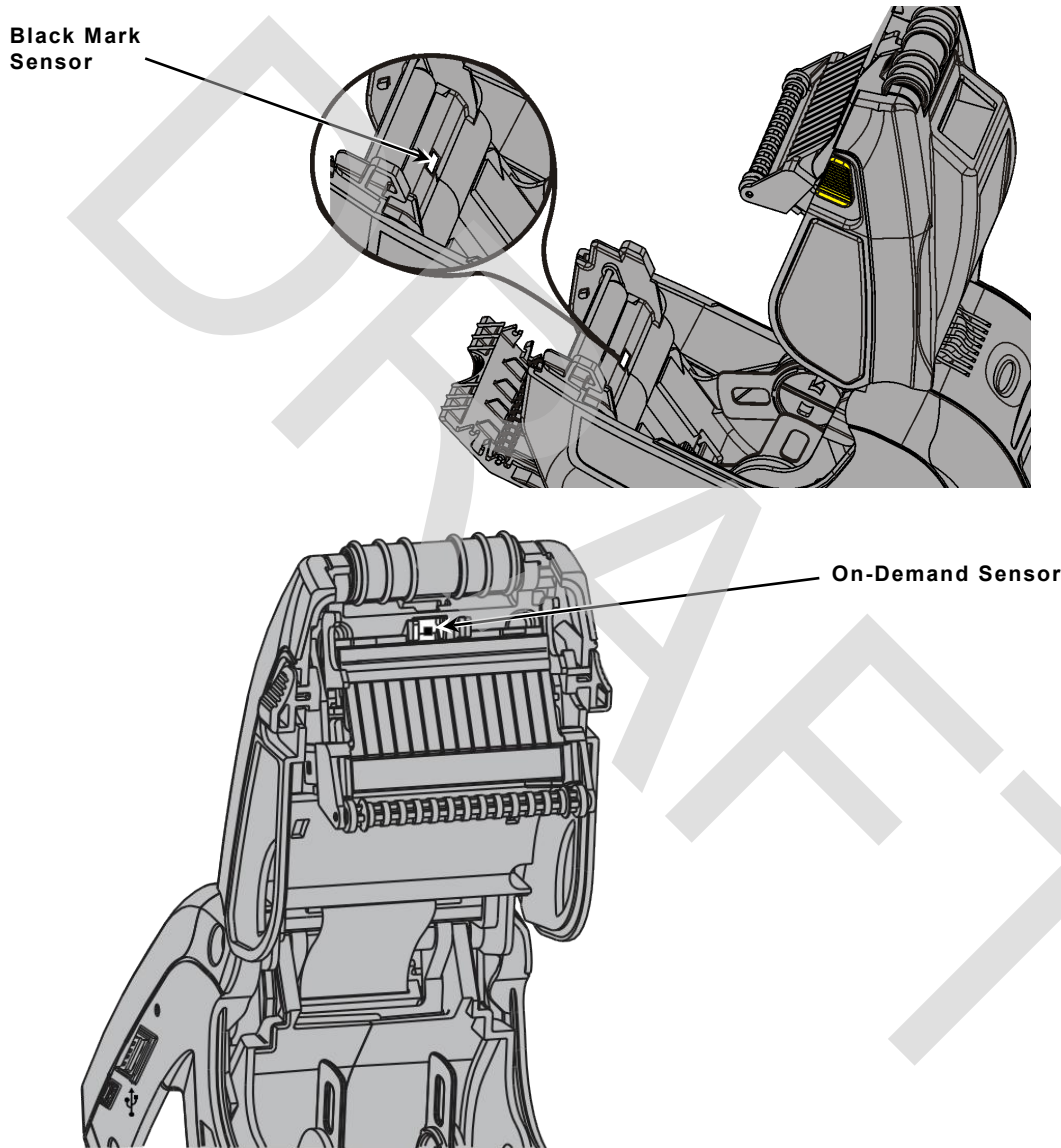

5. Reload the supplies.
6. Close the supply cover and the label deflector.

Cleaning the Display Screen and Scanner Window

Make sure the printer is turned off when cleaning the display and scanner window. Slightly dampen a soft cloth with distilled water and *gently* wipe the display and the scanner window.

Do not use household cleaners on the display or scanner window.

Do not press too hard on the scanner window – it may move or crack.

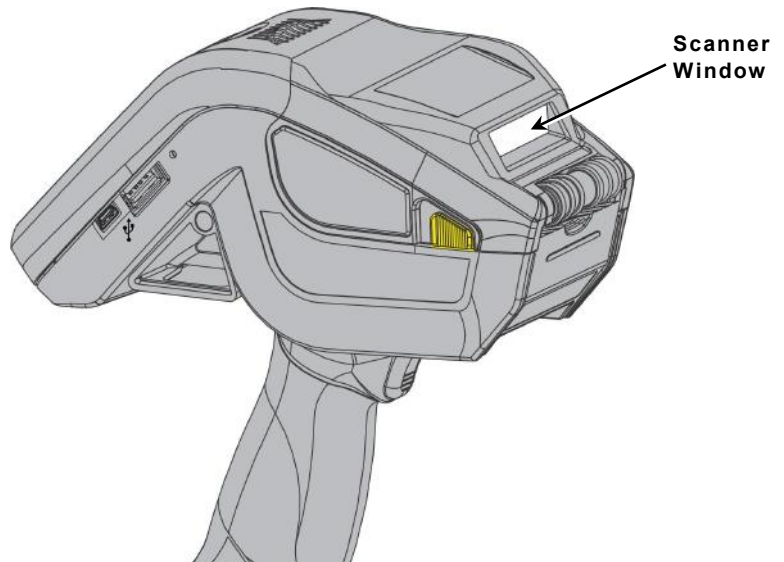

TROUBLESHOOTING

This chapter lists some common printer problems and their solutions.

Problem	Solution
Printer does not feed.	<p>Switch to a fully charged battery.</p> <p>Close the supply cover completely.</p> <p>Load the supply correctly. See “Loading Supplies” in Chapter 2 for more information.</p> <p>Check the platen roller for jammed labels.</p> <p>Make sure the pinch roller is in place.</p>
Printer does not print.	<p>Switch to a fully charged battery.</p> <p>Load the supply correctly. See “Loading Supplies” in Chapter 2 for more information.</p> <p>Clean the printhead. See “Cleaning the Printhead” in Chapter 4 for more information.</p>
Print has voids or is too light.	<p>Load the supply correctly. See “Loading Supplies” in Chapter 2 for more information.</p> <p>Close the supply cover completely.</p> <p>Switch to a fully charged battery.</p> <p>Clean the printhead. See “Cleaning the Printhead” in Chapter 4 for more information.</p> <p>Check the supply for damage or defects.</p>
Printer partially prints on the supply and fails to respond to the keypad or trigger.	<p>Load the supply correctly or load new supplies, if necessary. See “Loading Supplies” in Chapter 2 for more information.</p> <p>Clear any supply jams.</p> <p>Clean the printhead. See “Cleaning the Printhead” in Chapter 4 for more information.</p> <p>Switch to a fully charged battery.</p>
Scanner does not scan a bar code.	<p>See “Scanning Bar Codes” in Chapter 3 for more information.</p>
The display does not turn on.	<p>Make sure the power is on.</p> <p>Switch to a fully charged battery.</p>

Any RFID messages to note?

Checking the Software Version

To check the printer's software version: <- Where is this?

1. Turn on the printer.
2. From the printer's Main Menu, use ← or → until you see **Configuration**, then press **Enter**.
3. Use ← or → until you see **Version**, then press **Enter**.

The printer's version number is displayed. Press ESC to return to the previous menu.

4. Press **ESC** until you return to the Main Menu.

Printing a Test Label

To print a Test Label: <- Where is this?

1. From the printer's Main Menu, use ← or → until you see **Diagnostics**, then press **Enter**.
2. Use ← or → until you see **Printer**, then press **Enter**.
3. Use ← or → until you see **Test Labels**, then press **Enter**.
4. Select from the following test labels:

Select:

Diag Label

The following labels print:

Prints a label with version numbers, voltage, printhead information and blackmark sensor values.

```
Model: M6033
PE Firmware Rev: AB
PE Hardware Rev: AB
PE Voltage: 7.92 V
PE Current: 107 mA
PH Avg. Resistance: 347 ohms
Num Bad dots 0
PH Temperature (raw): 697
Blackmark sensor: 1.56 V
```

Test Pattern

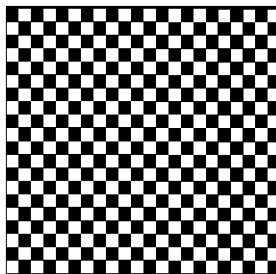

Prints a label to verify that the printhead strobes are working. If your printed sample has fewer lines or no lines, keep the sample and call Service.

Select:**The following labels print:**

Gray Scale

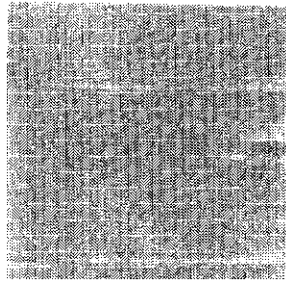

The gray scale test checks the uniformity of the printing. The printed sample should be uniformly gray across the supply. If you see voids, especially on the edges, keep the sample and call Service.

Label with voids

Serial Barcode Label

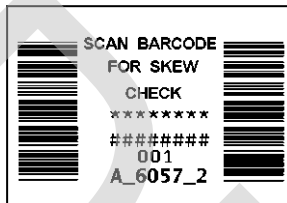

A label prints bar codes for you to scan to check the quality of serial bar codes.

Parallel Barcode Label



A label prints bar codes for you to scan to check the quality of parallel bar codes.

Error Codes

This section lists common error codes and their descriptions.

Code(s)	Description
004 - 005	Supply size is incorrect. Reload the correct supplies.
267 - 271 410 - 413	Communication error. See your System Administrator.
703 - 704	Supply Error. Load supplies or make sure they are loaded correctly. See "Loading Supplies" in Chapter 3 for more information.
706	Remove any jammed supplies. See "Clearing Supply Jams" in Chapter 5 for more information. If the supply is not jammed or you have removed the jam, and the error continues, see your System Administrator.
750	Printhead is overheated. Turn off the printer to let it cool.
751 - 753	The printer sensed a problem with a mark on the supplies. Check the supplies to see if they are loaded correctly.
756	The printer is out of supplies. Load supplies. See "Loading Supplies" in Chapter 3 for more information.
757	The calibrated supply length differs by plus or minus .25 inches from the format. Load supplies.
758	Check supply. Remove any printed labels. Check for a label jam. Clear the supply path or reload supplies.
762	Low battery. Recharge the battery. See "Charging the Main Battery" in Chapter 2 for more information.

763	Waiting to dispense label. Press the trigger.
768	Printhead error. See your System Administrator.
790 - 791	The printer is busy or has an error pending. Turn off the printer, wait two seconds, and then turn it back on.
904 - 911	System error. See your System Administrator.
SYSTEM ERROR VECTOR ##	System error. See your System Administrator.

Technical Support

If these solutions do not work or you have a problem or error code not listed, see your System Administrator or call Technical Support.

SPECIFICATIONS & ACCESSORIES

A

Specifications

Dimensions:	Width – 3.3" (84 mm) Length – 9.84" (250 mm) Height – 7.9" (201 mm) Weight – 2.0 lbs. (908 g) Shipping Weight – 5.9 lbs. (2.6 kg)
Printhead:	1.89" (48mm/384 dots) (203 dots per inch)
Printing:	Thermal direct (no ink /ribbon)
Print Speed:	Up to 5" (127 mm) per second
Memory:	2 GB RAM; 4 GB NAND Flash
Battery Type:	7.4V Lithium-Ion 3.6V Lithium-Ion (internal)
Battery Recharge Time:	1 – 3 hours, depending on the charger used.
Supply Sizes:	Widths: 1.2", 1.5", and 2.0" (30mm, 38mm, and 51mm) adjustable between 1.2 – 2.0" (30 mm – 51 mm) Lengths .55" – 8.0" (14mm –203mm) Peel mode supports .785" (20 mm) or greater lengths. Non-Peel mode supports .55" (14mm) or greater lengths. What about RFID peel mode?
Operating Temperature:	40°F – 110°F (4°C – 43°C)
Humidity (Operating & Storage):	5% – 90% non-condensing

- ◆ The optimal battery storage temperature is 50°F to 73°F (10°C to 23°C), with a maximum of 104°F (40°C). The battery may permanently lose its charge capacity if stored at temperatures less than 32°F (0°C) or greater than 104°F (40°C). For longest life, the battery should be stored in a cool, dry place.
- ◆ The recommended charging temperature is 68°F to 77°F (20°C to 25°C)
- ◆ Many factors affect your battery's performance, including the quantity of labels printed, percentage of black per label, and battery life.

Accessories

The following accessories are available:

Part Number	Description
M09462	Single-Station Battery Charger
M09465	Four-Station Battery Charger
114226	Cleaning Pen
M06054	Network Control Module Use one module with up to four 6055 Docking modules
M06055	Docking Module Connects to the Network Control Module. Holds the printer, charges the battery while inside the printer, and allows Ethernet communication with the printer.
M06056	Docking Module Stand alone, single printer charger that offers communication while charging.
part#?	Deluxe Hand Strap
part#?	Shoulder Strap
part#?	Petite Wrist Strap
part#?	Holster
125859	USB Cable
12009502	Extra Battery

DRAFT

DRAFT

DRAFT

DRAFT